

ORDERING REPLACEMENT PARTS

To order replacement parts, contact the ICON Health & Fitness, Ltd. office, or write:

ICON Health & Fitness, Ltd.
Unit 4
Revie Road Industrial Estate
Revie Road
Beeston
Leeds
LS11 8JG
UK

Tel:

08457 089 009

Fax: 0 (444) 113 387 7125

When ordering parts, please be prepared to give the following information:

- the MODEL NUMBER of the product (NTEVEX99830)
- the NAME of the product (NordicTrack® SL 850 exercise cycle)
- the SERIAL NUMBER of the product (see the front cover of this manual)
- the KEY NUMBER and DESCRIPTION of the part(s) (see page 25)

NordicTrack[®] SL 850

Class HC Fitness Product

USER'S MANUAL

Model No. NTEVEX99830
Serial No. _____

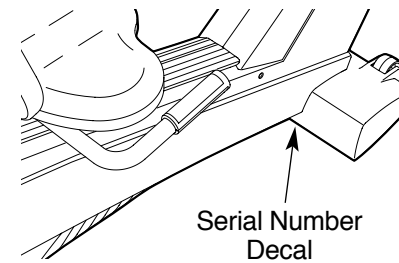

QUESTIONS?

As a manufacturer, we are committed to providing complete customer satisfaction. If you have questions, or if there are missing parts, please call:

08457 089 009

Or write:
ICON Health & Fitness, Ltd.
Unit 4
Revie Road Industrial Estate
Revie Road
Beeston
Leeds
LS11 8JG

email: csuk@iconeurope.com

CAUTION

Read all precautions and instructions in this manual before using this equipment. Keep this manual for future reference.

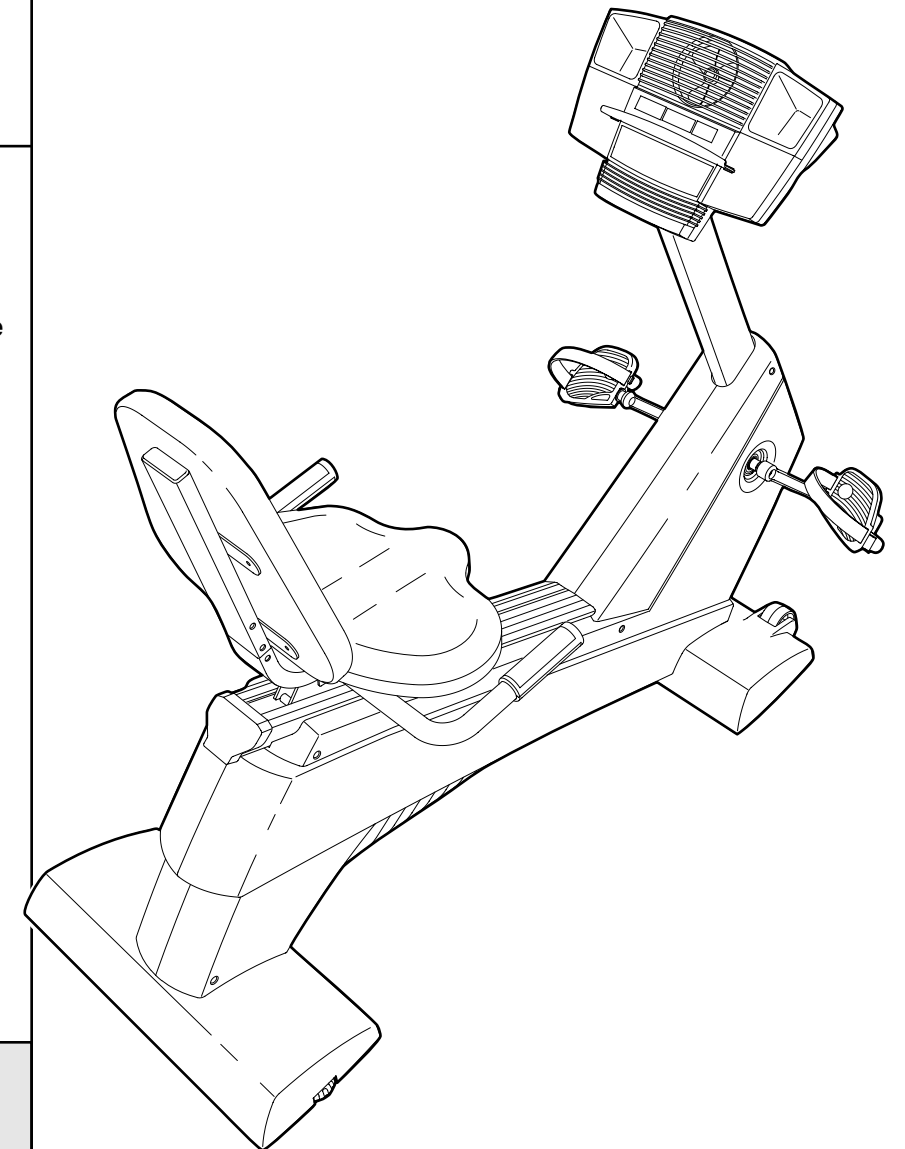

Visit our website at
www.iconeurope.com

NordicTrack[®]

SL 850

TABLE OF CONTENTS

IMPORTANT PRECAUTIONS	3
BEFORE YOU BEGIN	4
ASSEMBLY	5
HOW TO USE THE CHEST PULSE SENSOR	9
HOW TO OPERATE THE EXERCISE CYCLE	11
MAINTENANCE AND TROUBLESHOOTING	23
EXERCISE GUIDELINES	24
PART LIST	25
EXPLODED DRAWING	26
ORDERING REPLACEMENT PARTS	Back Cover

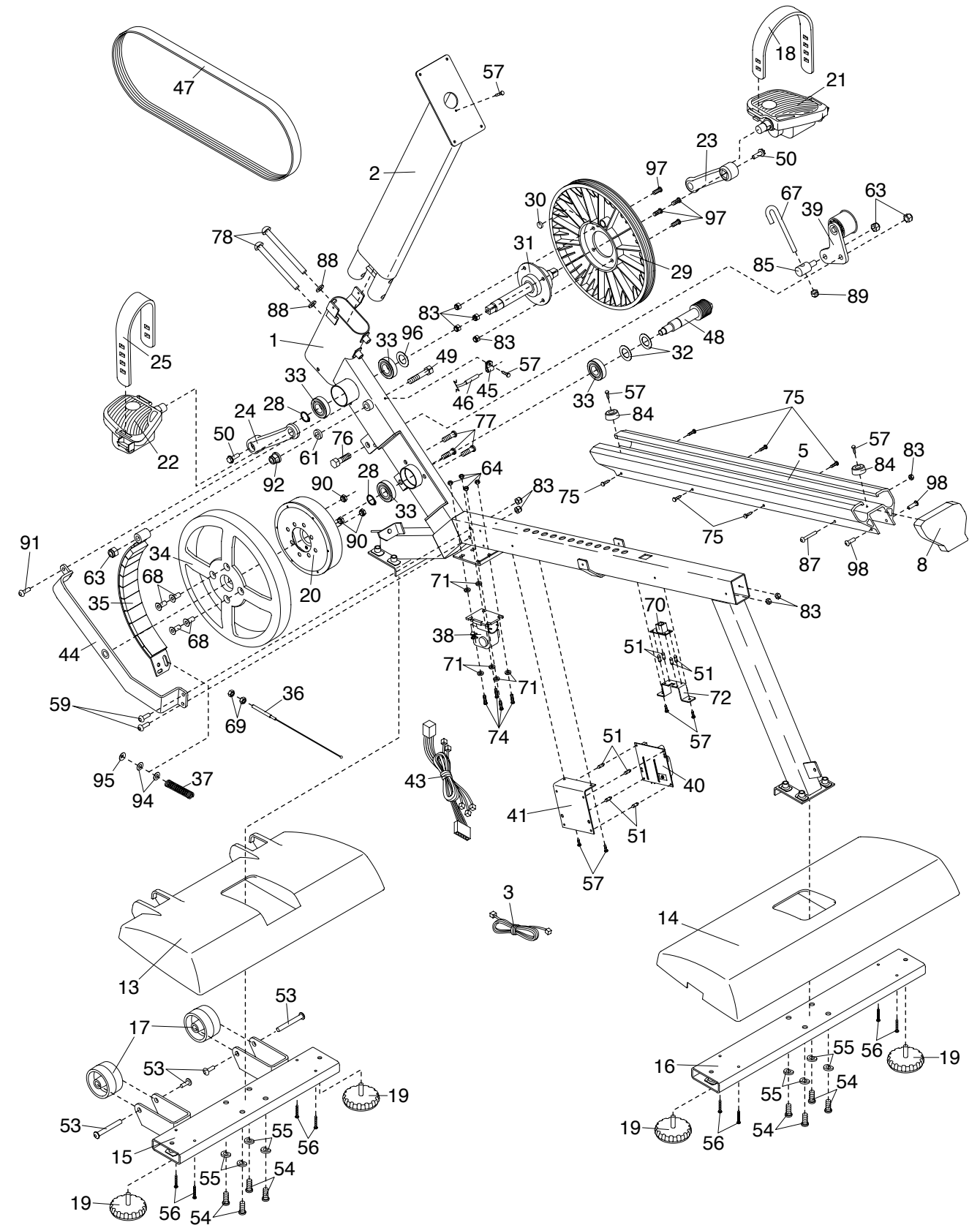

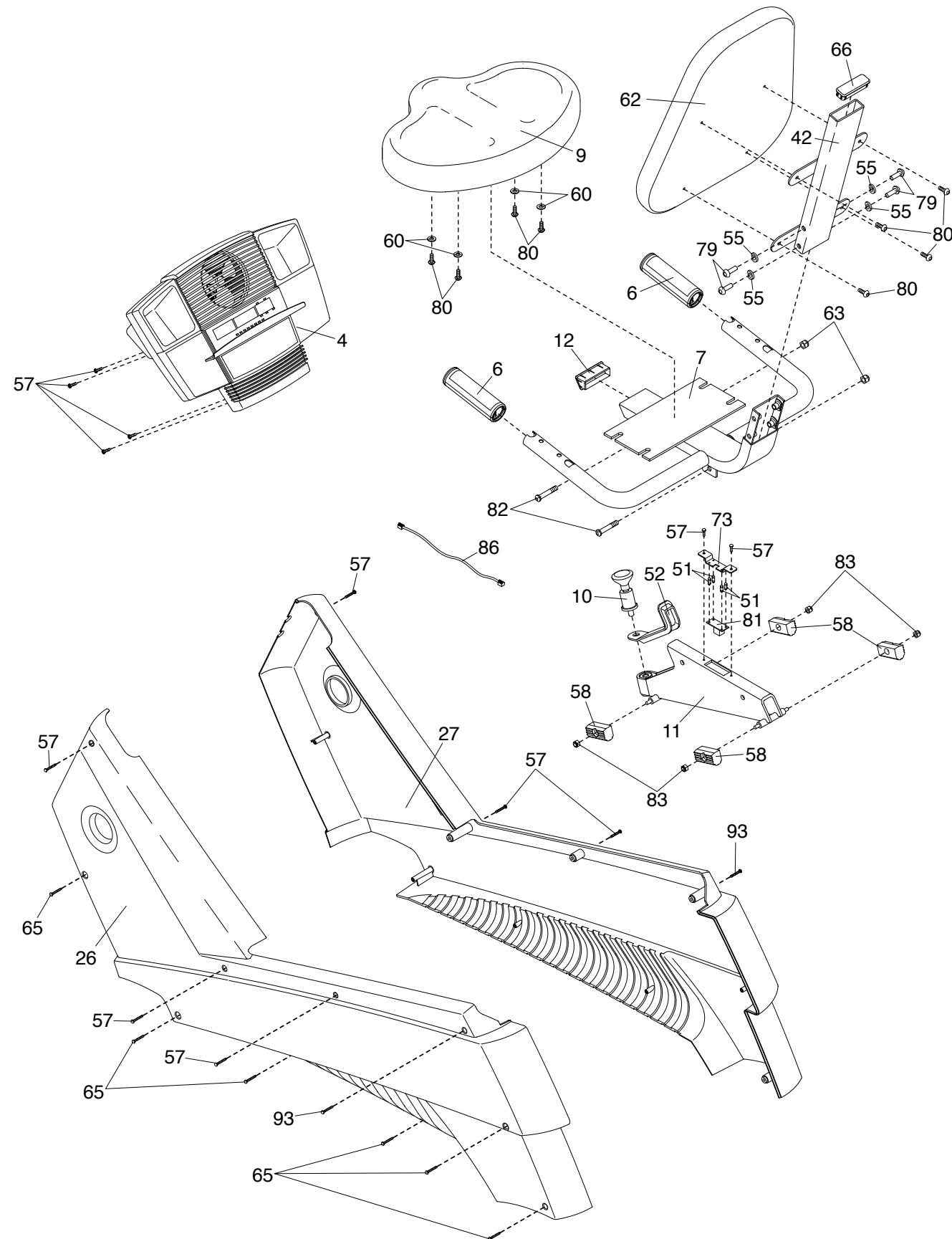

IMPORTANT PRECAUTIONS

⚠ WARNING: To reduce the risk of serious injury, read the following important precautions before using the exercise cycle.

1. Read all instructions in this manual before using the exercise cycle. Use the exercise cycle only as described.
2. It is the responsibility of the owner to ensure that all users of the exercise cycle are adequately informed of all precautions.
3. Use the exercise cycle indoors on a level surface. Keep the exercise cycle away from moisture and dust. Place a mat under the exercise cycle to protect the floor or carpet.
4. Inspect and properly tighten all parts regularly. Replace any worn parts immediately.
5. Keep children under the age of 12 and pets away from the exercise cycle at all times.
6. The exercise cycle should not be used by persons weighing more than 115 kg (250 lbs).
7. Wear suitable clothing when using the exercise cycle; do not wear loose clothing that could become caught on the exercise cycle. Always wear athletic shoes.
8. Always keep your back straight when using the exercise cycle. Do not arch your back.
9. If you feel pain or dizziness whilst exercising, stop immediately and cool down.
10. The pulse sensors are not medical devices. Various factors, including the user's movement, may affect the accuracy of heart rate readings. The pulse sensors are intended only as exercise aids in determining heart rate trends in general.
11. The exercise cycle is intended for in-home use only. Do not use the exercise cycle in a commercial, rental, or institutional setting.

⚠ WARNING: Before beginning this or any exercise program, consult your physician. This is especially important for persons over the age of 35 or persons with pre-existing health problems. Read all instructions before using. ICON assumes no responsibility for personal injury or property damage sustained by or through the use of this product.

BEFORE YOU BEGIN

Congratulations for selecting the new NordicTrack® SL 850 exercise cycle. Cycling is one of the most effective exercises for increasing cardiovascular fitness, building endurance, and toning the entire body. The NordicTrack® SL 850 exercise cycle offers an impressive array of features designed to let you enjoy this healthful exercise in the comfort and privacy of your home.

For your benefit, read this manual carefully before using the exercise cycle. If you have questions after

reading this manual, please call our Customer Service Department at **08457 089 009**. To help us assist you, please mention the product model number and serial number when calling. The model number is NTEVEX99830. The serial number can be found on a decal attached to the exercise cycle (see the front cover of this manual for the location of the decal).

Before reading further, please familiarise yourself with the parts that are labeled in the drawing below.

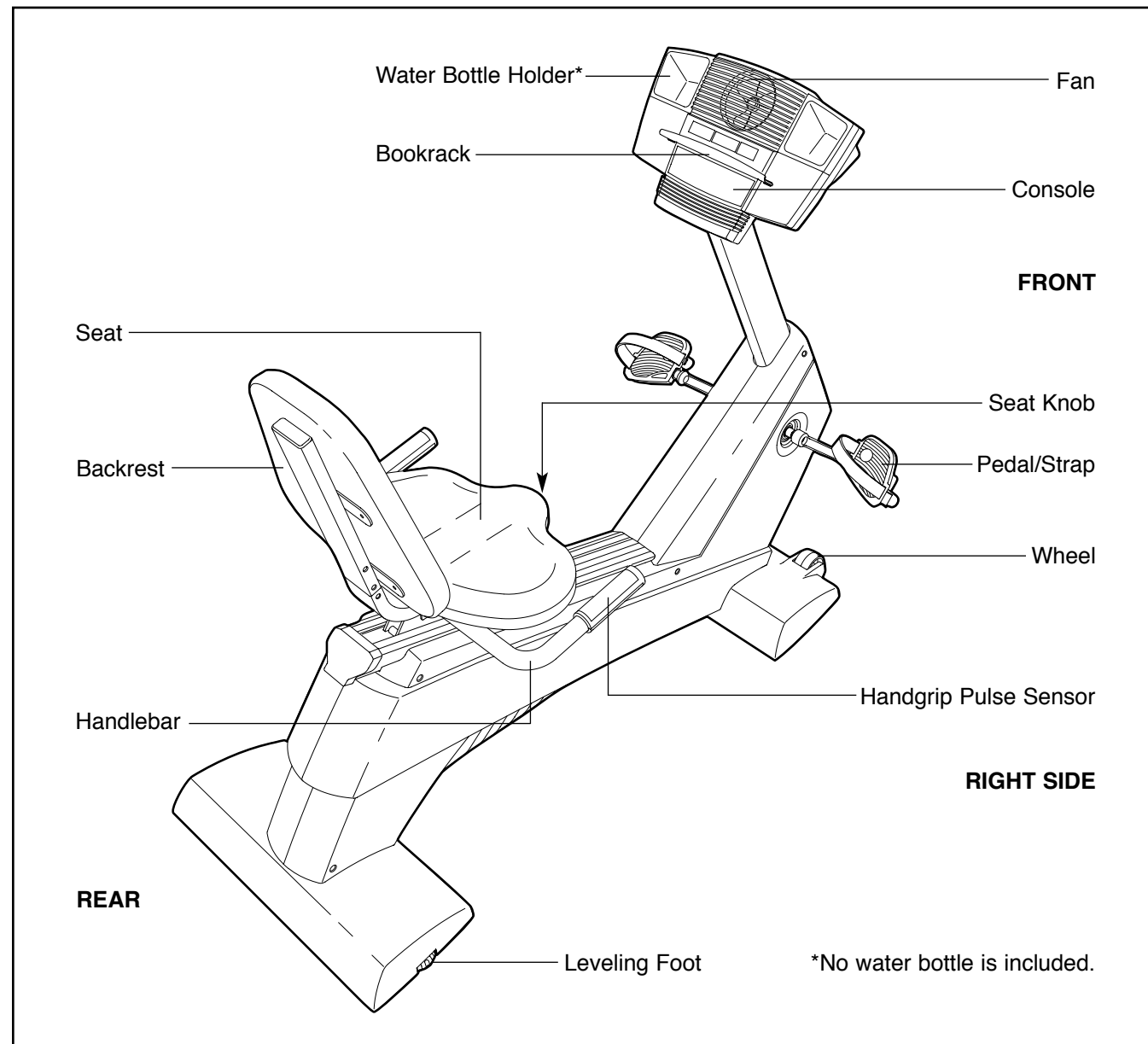

PART LIST—Model No. NTEVEX99830

R1003A

Key No.	Qty.	Description	Key No.	Qty.	Description
1	1	Frame	52	1	Seat Carriage Endcap
2	1	Upright	53	2	Bolt Set
3	1	Pulse Wire	54	8	M8 x 40mm Button Screw
4	1	Console	55	12	M8 Split Washer
5	1	Seat Rail	56	8	M4 x 38mm Screw
6	2	Pulse Sensor	57	20	M4 x 16mm Screw
7	1	Seat Frame	58	4	Carriage Bushing
8	1	Seat Rail Endcap	59	2	M6 x 50mm Bolt
9	1	Seat	60	4	M8 Washer
10	1	Seat Knob	61	1	M10 Washer
11	1	Seat Carriage	62	1	Backrest
12	1	Seat Frame Endcap	63	5	M10 Nylon Locknut
13	1	Front Stabiliser Cover	64	4	M5 Nylon Locknut
14	1	Rear Stabiliser Cover	65	6	M4 x 25mm Screw
15	1	Front Stabiliser	66	1	Backrest Frame Endcap
16	1	Rear Stabiliser	67	1	Idler Bolt
17	2	Wheel	68	4	M8 x 14mm Tapered Bolt
18	1	Right Pedal Strap	69	2	M6 Nut
19	4	Leveling Foot	70	1	Frame RJ14 Outlet
20	1	Generator	71	6	M5 Washer
21	1	Right Pedal	72	1	Frame RJ14 Bracket
22	1	Left Pedal	73	1	Carriage RJ14 Bracket
23	1	Right Crank Arm	74	4	M5 x 16mm Bolt
24	1	Left Crank Arm	75	6	M5 x 16mm Round Head Screw
25	1	Left Pedal Strap	76	1	M10 x 43mm Bolt
26	1	Left Side Shield	77	3	M8 x 35mm Screw
27	1	Right Side Shield	78	2	M10 x 110mm Button Screw
28	2	Snap Ring	79	4	M8 x 25mm Button Screw
29	1	Pulley	80	8	1/4" x 16mm Button Screw
30	1	Magnet	81	1	Carriage RJ14 Outlet
31	1	Crank Assembly	82	2	M10 x 52mm Button Bolt
32	2	Pulley Spacer	83	13	M6 Nylon Locknut
33	4	Crank Bearing	84	2	Bumper
34	1	Flywheel	85	1	"J" Bolt Bushing
35	1	"C" Magnet	86	1	RJ14 Cable
36	1	Resistance Cable	87	1	M6 x 52mm Bolt
37	1	Spring	88	2	M10 Split Washer
38	1	Resistance Motor	89	1	M8 Nylon Locknut
39	1	Idler Arm	90	3	M8 Nylon Jam Nut
40	1	Control Board	91	1	M6 x 45mm Bolt
41	1	Control Bracket	92	1	M10 Flange Nut
42	1	Backrest Frame	93	2	M5 x 25mm Round Head Screw
43	1	Wire Harness	94	2	M4 Washer
44	1	Flywheel Bracket	95	1	M4 Push Nut
45	1	Clamp	96	1	Thrust Washer
46	1	Reed Switch/Wire	97	4	M6 x 18mm Bolt
47	1	Drive Belt	98	2	M6 x 18mm Round Head Screw
48	1	Flywheel Axle	#	3	Hex Key
49	1	M10 x 82mm Bolt	#	1	User's Manual
50	2	Flange Screw	#	1	Chest Strap
51	12	Standoff	#	1	Sensor Unit

Note: "#" indicates a non-illustrated part. Specifications are subject to change without notice. See the back cover of this manual for information about ordering replacement parts.

EXERCISE GUIDELINES

⚠️ WARNING:

- Before beginning this or any exercise program, consult your physician. This is especially important for individuals over the age of 35 or individuals with pre-existing health problems.
- The pulse sensors are not medical devices. Various factors, including the user's movement, may affect the accuracy of heart rate readings. The pulse sensors are intended only as exercise aids in determining heart rate trends in general.

The following guidelines will help you to plan your exercise program. Remember that proper nutrition and adequate rest are essential for successful results.

EXERCISE INTENSITY

Whether your goal is to burn fat or to strengthen your cardiovascular system, the key to achieving the desired results is to exercise with the proper intensity. The proper intensity level can be found by using your heart rate as a guide. The chart below shows recommended heart rates for fat burning, maximum fat burning, and cardiovascular (aerobic) exercise.

165	155	145	140	130	125	115	♥
145	138	130	125	118	110	103	♥
125	120	115	110	105	95	90	♥
20	30	40	50	60	70	80	

To find the proper heart rate for you, first find your age at the bottom of the chart (ages are rounded off to the nearest ten years). Next, find the three numbers above your age; the three numbers are your "training zone." The lowest number is the recommended heart rate for fat burning; the middle number is the recommended heart rate for maximum fat burning; and the highest number is the heart rate for aerobic exercise.

Fat Burning

To burn fat effectively, you must exercise at a relatively low intensity level for a sustained period of time. During the first few minutes of exercise, your body uses easily accessible carbohydrate calories for energy. Only after the first few minutes of exercise does your body begin to use stored fat calories for energy. If your goal is to burn fat, adjust the intensity of your exercise until your heart rate is near the lowest number or the middle number in your training zone as you exercise.

Aerobic Exercise

If your goal is to strengthen your cardiovascular system, your exercise must be "aerobic." Aerobic exercise is activity that requires large amounts of oxygen for prolonged periods of time. This increases the demand on the heart to pump blood to the muscles, and on the lungs to oxygenate the blood. For aerobic exercise, adjust the intensity of your exercise until your heart rate is near the highest number in your training zone.

WORKOUT GUIDELINES

Each workout should include the following three parts:

A warm-up, consisting of 5 to 10 minutes of stretching and light exercise. A proper warm-up increases your body temperature, heart rate, and circulation in preparation for exercise.

Training zone exercise, consisting of 20 to 30 minutes of exercising with your heart rate in your training zone. (During the first few weeks of your exercise program, do not keep your heart rate in your training zone for longer than 20 minutes.)

A cool-down, with 5 to 10 minutes of stretching. This will increase the flexibility of your muscles and will help to prevent post-exercise problems.

EXERCISE FREQUENCY

To maintain or improve your condition, plan three workouts each week, with at least one day of rest between workouts. After a few months of regular exercise, you may complete up to five workouts each week, if desired. The key to success is make exercise a regular and enjoyable part of your everyday life.

ASSEMBLY

Assembly requires two persons. Place all parts of the exercise cycle in a cleared area and remove the packing materials. Do not dispose of the packing materials until assembly is completed.

Assembly requires the included tools and your own adjustable spanner .

Use the drawings below to identify the small parts used in assembly. The number in parenthesis below each drawing refers to the key number of the part, from the PART LIST on page 25. The second number refers to the quantity needed for assembly. **Note: Some small parts may have been pre-assembled for shipping. If a part is not in the parts bag, check to see if it has been pre-assembled.**

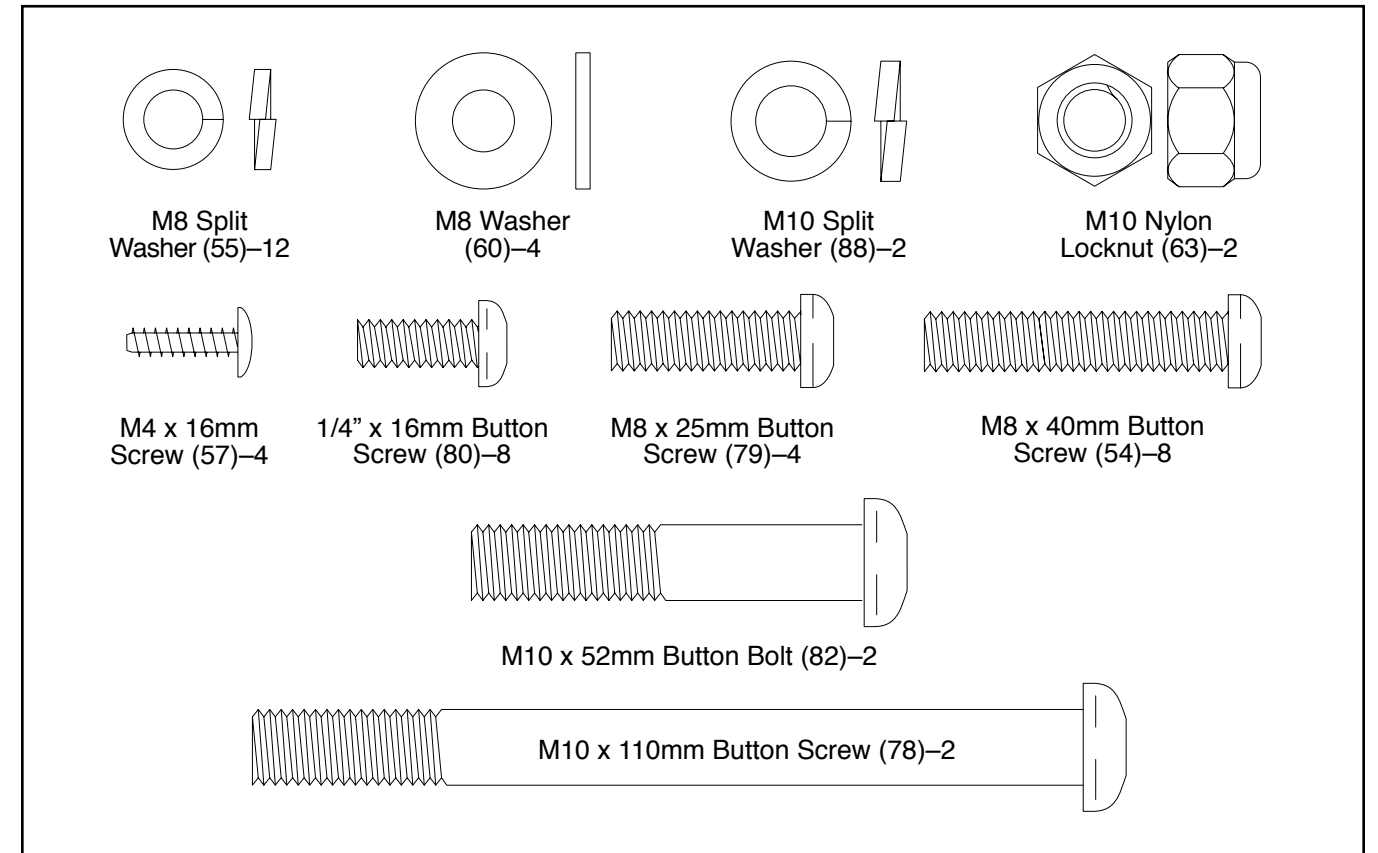

1. Identify the Front Stabiliser (15). Whilst another person lifts the front of the Frame (1), attach the Front Stabiliser to the Frame with four M8 x 40mm Button Screws (54) and four M8 Split Washers (55).

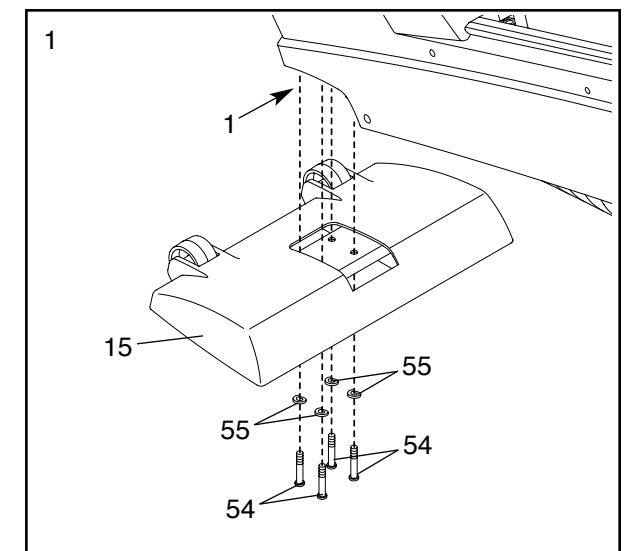

2. Whilst another person lifts the rear of the Frame (1), attach the Rear Stabiliser (16) to the Frame with four M8 x 40mm Button Screws (54) and four M8 Split Washers (55).

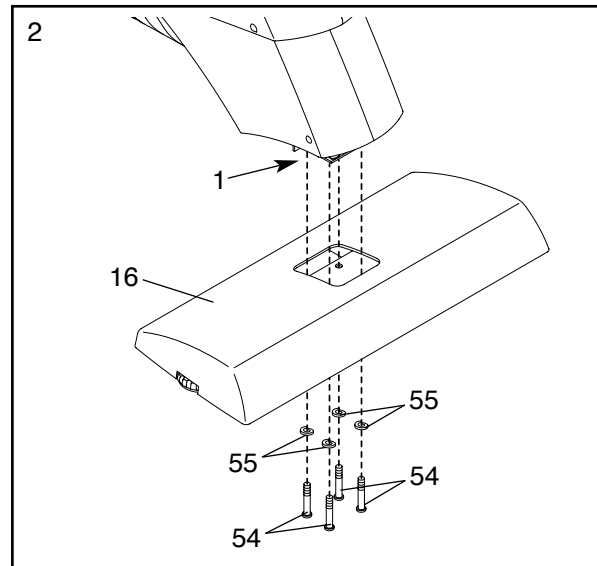

3. Have another person hold the Upright (2) in the position shown. See the inset drawing. Locate the wire extending from the bottom of the Upright. Tie the wire around the ends of the Wire Harness (43) and the Pulse Wire (3) as shown. Carefully pull the wire up through the Upright until the Wire Harness and the Pulse Wire are extending from the top of the Upright. Untie the wire and discard it. **Carefully pull the ends of the Wire Harness and the Pulse Wire to remove any slack.**

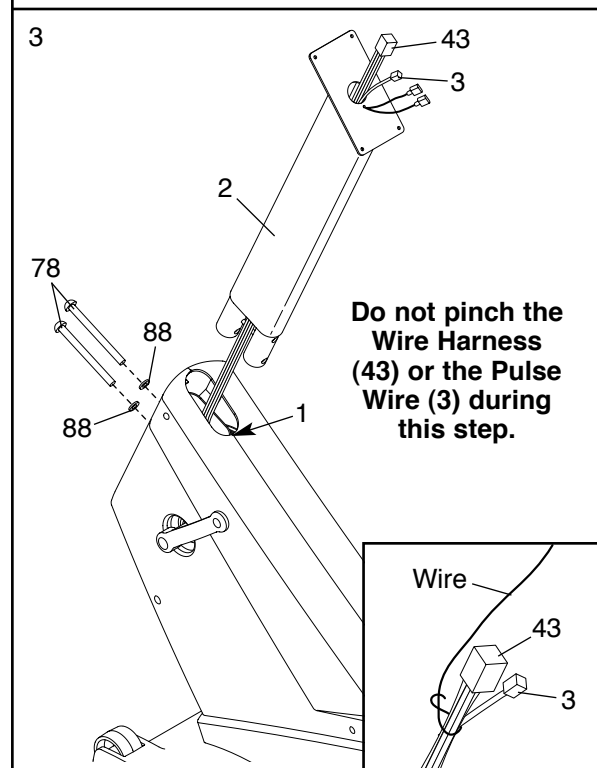

Insert the Upright (2) into the Frame (1). **Be careful to avoid pinching the Wire Harness (43) or the Pulse Wire (3).** Attach the Upright with two M10 x 110mm Button Screws (78) and two M10 Split Washers (88).

4. Have another person hold the Console (4) near the Upright (2).

Connect the Wire Harness (43) to the wire harness on the Console (4). Connect the Pulse Wire (3) to the pulse wire on the Console. Next, locate the two ground wires that are connected with a screw to the Upright (2). Connect the ground wires to the two smallest wires on the Console.

Carefully insert all excess wiring down into the Upright (2). Attach the Console (4) to the Upright with four M4 x 16mm Screws (57). **Be careful to avoid pinching the wires.**

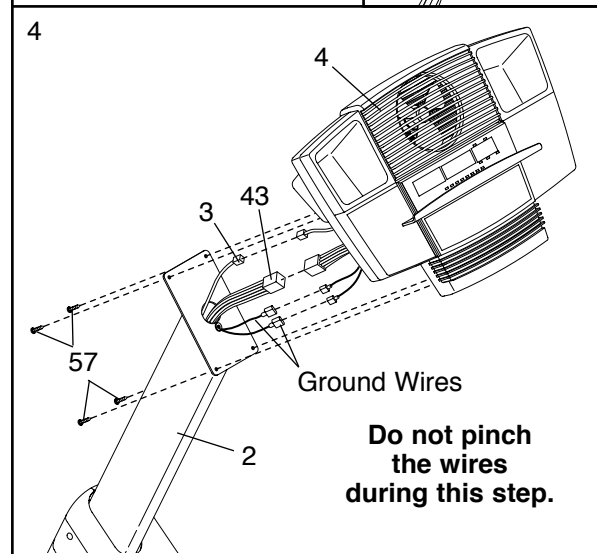

MAINTENANCE AND TROUBLESHOOTING

Inspect and properly tighten all parts of the exercise cycle regularly. To clean the exercise cycle, use a soft, damp cloth. Keep liquids away from the console and keep the console out of direct sunlight.

HOW TO ADJUST THE REED SWITCH

If the console does not display correct feedback, the reed switch should be adjusted. To adjust the reed switch, the Right Side Shield (27) must first be removed. Remove the indicated M4 x 25mm Screws (65) from the Left Side Shield (26).

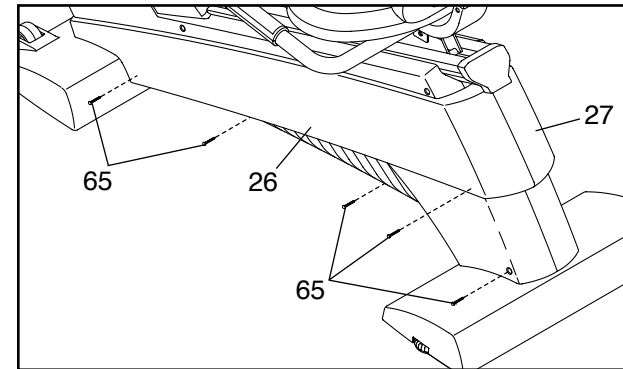

Next, remove the indicated M5 x 25mm Screw (93) and M4 x 16mm Screws (57) from the Right Side Shield (27). Using an adjustable wrench, turn the Right Pedal (21) counterclockwise and remove it. Turn the Right Crank Arm (23) so that it is pointing toward the front of the exercise cycle, and then slide off the Right Side Shield.

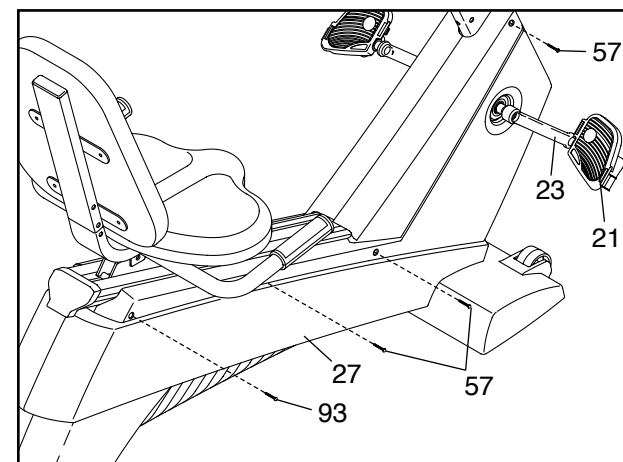

Locate the Reed Switch (46). Turn the Right Crank Arm (23) until the Magnet (30) is aligned with the Reed Switch. Loosen, but do not remove, the indicated M4 x 16mm Screw (57). Slide the Reed Switch slightly closer to or away from the Magnet. Then, retighten the Screw. Turn the Right Crank Arm for a moment. Repeat until the console displays correct feedback. When the Reed Switch is correctly adjusted, reattach the Right Side Shield (27) and the Right Pedal (21).

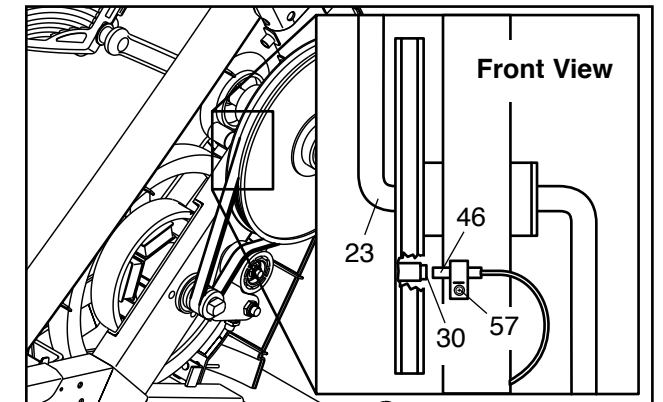

HOW TO ADJUST THE DRIVE BELT

If you can feel the pedals slip whilst you are pedaling, even when the resistance is adjusted to the highest level, the Drive Belt (47) may need to be adjusted. To adjust the Drive Belt, you must first remove the right side shield. See HOW TO ADJUST THE REED SWITCH at the left and remove the right side shield.

Next, turn the indicated M10 Nylon Locknut (63) until the Drive Belt (47) is properly tightened. Then, reattach the right side shield.

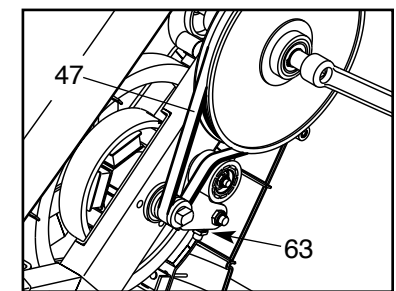

PULSE SENSOR TROUBLESHOOTING

If the chest pulse sensor does not function properly, see CHEST PULSE SENSOR TROUBLESHOOTING on pages 9 and 10. If the handgrip pulse sensor does not function properly, see step 5 on page 14.

HOW TO USE PROGRAMS DIRECTLY FROM OUR WEB SITE

Our Web site at www.iFIT.com allows you to play iFIT.com audio and video programs directly from the internet. To use programs from our Web site, the exercise cycle must be connected to your home computer. See HOW TO CONNECT YOUR COMPUTER on page 19. In addition, you must have an internet connection and an internet service provider. A list of specific system requirements is found on our Web site.

Follow the steps below to use a program from our Web site.

1 Begin pedaling to activate the console.

See step 1 on page 13.

2 Select the iFIT.com mode.

To select the iFIT.com mode, press the iFIT.com button. The indicator above the button will light.

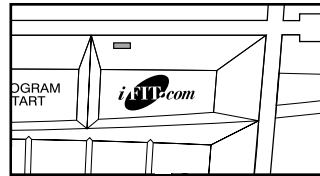

3 Go to your computer and start an internet connection.

4 Start your Web browser, if necessary, and go to our Web site at www.iFIT.com.

5 Follow the desired links on our Web site to select a program.

Read and follow the on-line instructions for using a program.

6 Follow the on-line instructions to start the program.

When you start the program, an on-screen countdown will begin.

7 Return to the exercise cycle and begin pedaling.

When the on-screen countdown ends, the program will begin. The program will function in almost the same way as a resistance and pace program (see step 3 on page 15). However, an electronic “chirping” sound will alert you when the resistance setting and/or the target pace setting is about to change.

8 Monitor your progress with the matrix and the two displays.

See step 4 on page 13.

9 Measure your heart rate if desired.

See step 5 on page 14.

10 Turn on the fan if desired.

See step 6 on page 14.

11 When you are finished exercising, the console will automatically turn off.

See step 7 on page 14.

5. Attach the Seat (9) to the Seat Frame (7) with four 1/4” x 16mm Button Screws (80) and four M8 Washers (60).

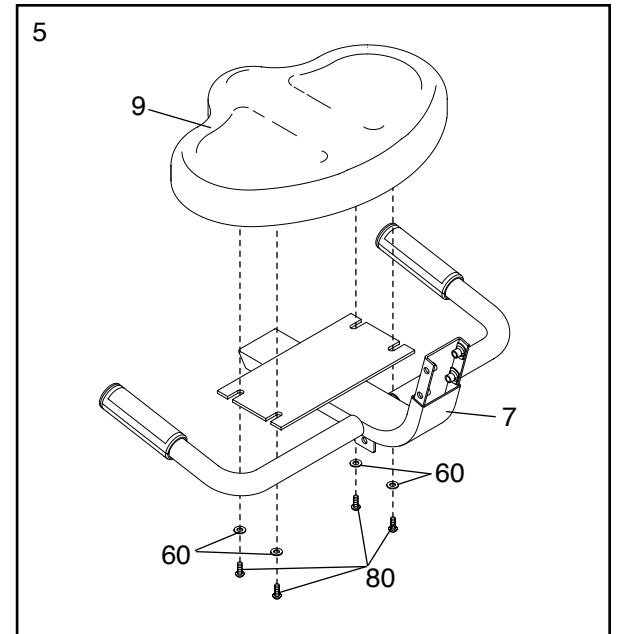

6. Pull the Seat Knob (10) and slide the Seat Carriage toward the rear of the Seat Rail (5).

Have another person hold the Seat Frame (7) near the Seat Carriage (11). Locate the two pulse wires extending from the Seat Frame. Connect each pulse wire to the pulse wire of the same color in the Seat Carriage. Insert the excess wiring up into the Seat Frame, and set the Seat Frame on the Seat Carriage. Attach the Seat Frame with two M10 x 52mm Button Bolts (82) and two M10 Nylon Locknuts (63). **Be careful to avoid damaging the pulse wires with the Bolts.**

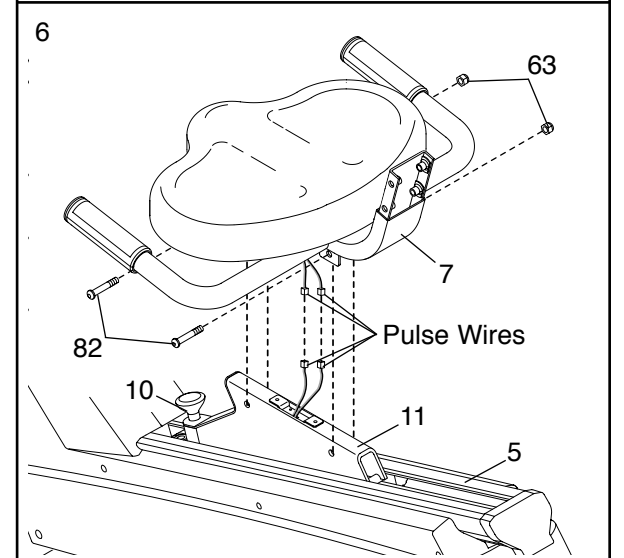

7. Attach the Backrest (62) to the Backrest Frame (42) with four 1/4” x 16mm Button Screws (80).

Slide the Backrest Frame (42) onto the Seat Frame (7). Attach the Backrest Frame with four M8 x 25mm Button Screws (79) and four M8 Split Washers (55).

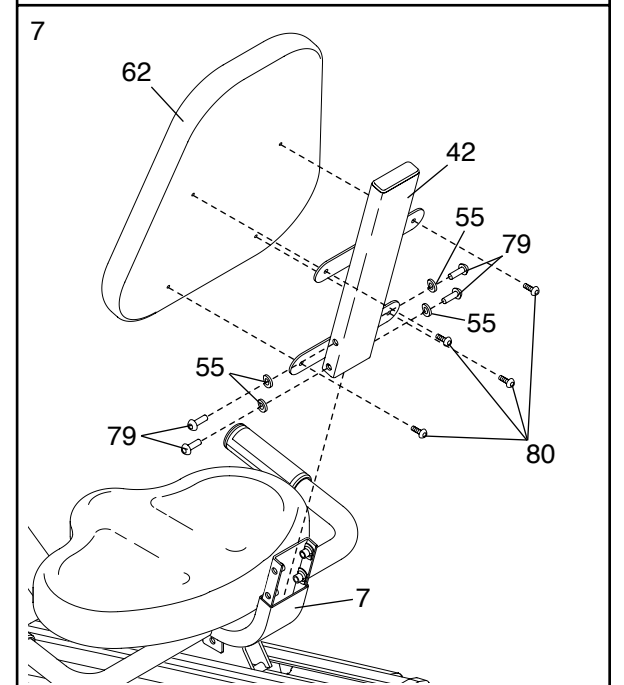

8. Identify the Left Pedal (22), which is marked with an "L." Using an adjustable wrench, **firmly tighten** the Left Pedal counterclockwise into the Left Crank Arm (24). Tighten the Right Pedal (not shown) clockwise into the Right Crank Arm. **Important: Tighten both Pedals as firmly as possible. After using the exercise cycle for one week, retighten the Pedals. For best performance, the Pedals must be kept tightened.**

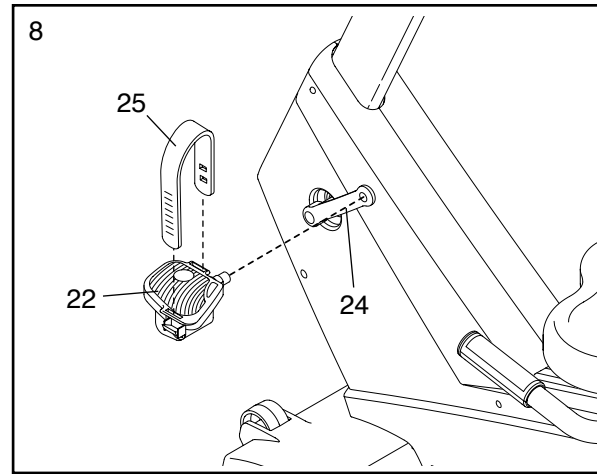

Identify the Left Pedal Strap (25), which is marked with an "L." Attach the Left Pedal Strap to the Left Pedal (22), and adjust it to the desired position. Attach and adjust the Right Pedal Strap (not shown) in the same way.

9. **Make sure that all parts are properly tightened before you use the exercise cycle.** Note: After assembly is completed, some extra parts may be left over. Place a mat beneath the exercise cycle to protect the floor.

HOW TO USE iFIT.COM CD AND VIDEO PROGRAMS

To use iFIT.com CDs or videocassettes, the exercise cycle must be connected to your portable CD player, portable stereo, home stereo, computer with CD player, or VCR. See HOW TO CONNECT YOUR CD PLAYER, VCR, OR COMPUTER on pages 18 to 20. **To purchase iFIT.com CDs and videocassettes, visit our Web site at www.iFIT.com.**

Follow the steps below to use an iFIT.com CD or video program.

1 Begin pedaling to activate the console.

See step 1 on page 13.

2 Select the iFIT.com mode.

To select the iFIT.com mode, press the iFIT.com button. The indicator above the button will light.

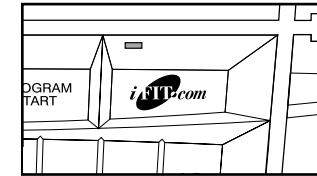

3 Insert the iFIT.com CD or videocassette.

If you are using an iFIT.com CD, insert the CD into your CD player. If you are using an iFIT.com videocassette, insert the videocassette into your VCR.

4 Press the play button on your CD player or VCR.

A moment after the play button is pressed, your personal trainer will begin guiding you through

your workout. Simply follow your personal trainer's instructions.

The program will function in almost the same way as a resistance and pace program (see step 3 on page 15). However, an electronic "chirping" sound will alert you when the resistance setting and/or the target pace setting is about to change.

Note: If the resistance of the exercise cycle and/or the target pace setting does not change when a "chirp" is heard:

- **Make sure that the indicator above the iFIT.com button is lit.**

- **Adjust the volume of your CD player or VCR. If the volume is too high or too low, the console may not detect the program signals.**

- **Make sure that the audio cable is properly connected and that it is fully plugged in.**

5 Monitor your progress with the matrix and the two displays.

See step 4 on page 13.

6 Measure your heart rate if desired.

See step 5 on page 14.

7 Turn on the fan if desired.

See step 6 on page 14.

8 When you are finished exercising, the console will automatically turn off.

See step 7 on page 14.

HOW TO CONNECT YOUR VCR

Note: If your VCR has an unused AUDIO OUT jack, see instruction A below. If the AUDIO OUT jack is being used, see instruction B. If you have a TV with a built-in VCR, see instruction B. If your VCR is connected to your home stereo, see HOW TO CONNECT YOUR HOME STEREO on page 19.

A. Plug one end of the audio cable into the jack beneath the console. Plug the other end of the audio cable into the adaptor. Plug the adaptor into the AUDIO OUT jack on your VCR.

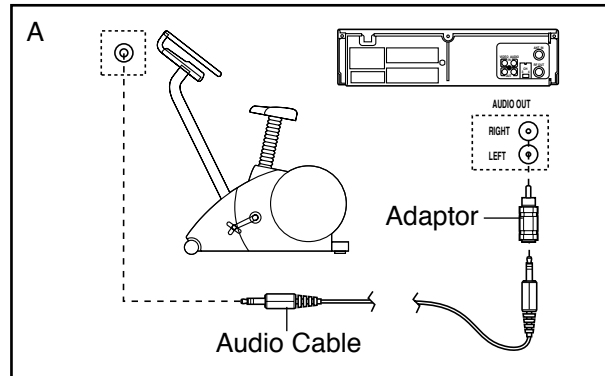

B. Plug one end of the audio cable into the jack beneath the console. Plug the other end of the audio cable into the adaptor. Plug the adaptor into an RCA Y-adaptor (available at electronics stores). Next, remove the wire that is currently plugged into the AUDIO OUT jack on your VCR and plug the wire into the unused side of the Y-adaptor. Plug the Y-adaptor into the AUDIO OUT jack on your VCR.

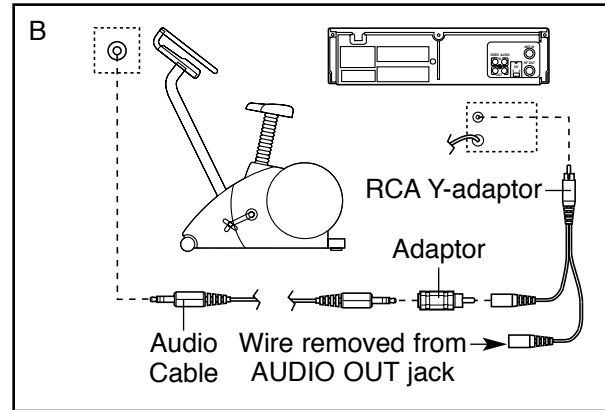

HOW TO USE THE CHEST PULSE SENSOR

HOW TO PUT ON THE CHEST PULSE SENSOR

The chest pulse sensor consists of two components: the chest strap and the sensor unit. Follow the steps below to put on the chest pulse sensor.

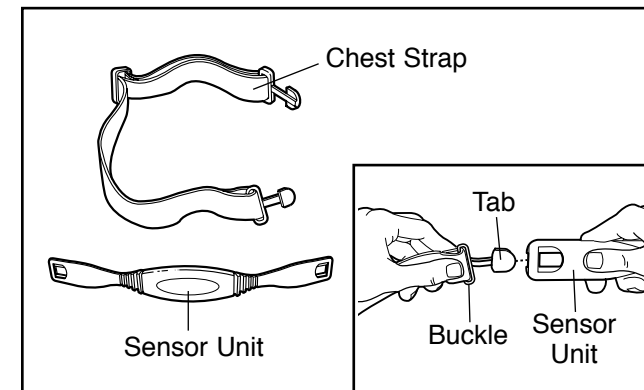

1 See the inset drawing above. Insert the tab on one end of the chest strap through one end of the sensor unit. Press the end of the sensor unit under the buckle on the chest strap.

2 Wrap the chest pulse sensor around your chest. Attach the free end of the chest strap to the sensor unit as described above. Adjust the length of the chest strap, if necessary. The chest pulse sensor should be under your clothes, against your skin, and as high under the pectoral muscles or breasts as is comfortable. Make sure that the logo is right-side-up and facing forward.

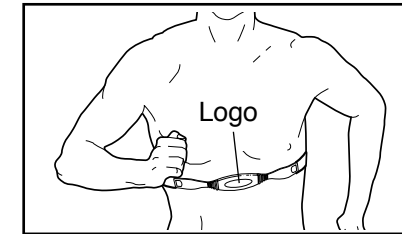

3 Pull the sensor unit away from your body a few inches and locate the two electrode areas on the inner side. Using a saline solution such as saliva or contact lens solution, wet both electrode areas. Return the sensor unit to a position against your chest.

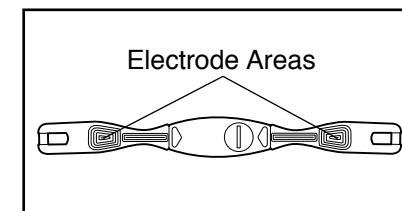

CHEST PULSE SENSOR TROUBLESHOOTING

If the chest pulse sensor does not function properly, or if the displayed heart rate is excessively high or low, try the troubleshooting steps below.

- Make sure that you are wearing the chest pulse sensor as described at the left. If the chest pulse sensor does not function when positioned as described, move it slightly lower or higher on your chest.
- Each time you use the chest pulse sensor, use saline solution such as saliva or contact lens solution to wet the two electrode areas on the sensor unit (see the drawing below). If heart rate readings do not appear until you begin perspiring, re-wet the electrode areas.
- Make sure that you are within arm's length of the console. **For the console to display heart rate readings, the user must be within arm's length of the console.**
- If you wear the chest pulse sensor and hold the handgrip pulse sensor at the same time, the console may not display your heart rate accurately.
- The chest pulse sensor is designed to work with people who have normal heart rhythms. Heart rate reading problems may be caused by medical conditions such as premature ventricular contractions (pvc's), tachycardia bursts, and arrhythmia.
- The operation of the chest pulse sensor can be affected by magnetic interference caused by high power lines or other sources. If it is suspected that magnetic interference may be causing a problem, try relocating your exercise equipment.
- If the chest pulse sensor still does not function properly, test the chest pulse sensor in the following way:

Hold the chest pulse sensor and place your thumbs over the electrode areas as shown. Next, hold the chest pulse sensor near the console. Whilst holding one thumb stationary, begin tapping the other thumb against the electrode area at a rate of about one tap per second. Check the heart rate reading on the console.

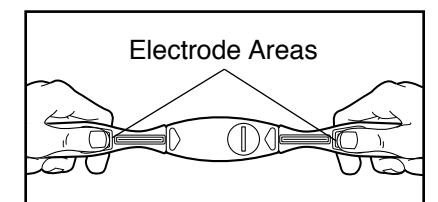

- If the chest pulse sensor does not function properly after you have followed all of the above instructions, the battery should be replaced in the following way:

Locate the battery cover on the back of the sensor unit. Insert a coin into the slot in the cover, turn the cover counterclockwise, and remove the cover.

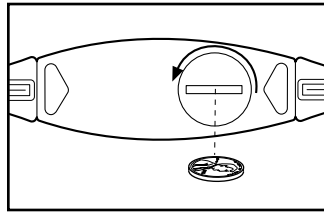

Remove the old battery and insert a new CR 2032 battery. **Make sure that the battery is turned so the writing is on top.** Replace the battery cover and turn it clockwise to close it.

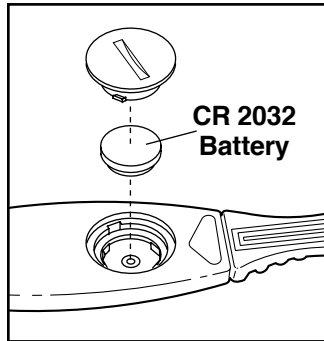

CHEST PULSE SENSOR CARE

- Thoroughly dry the chest pulse sensor after each use. The chest pulse sensor is activated when the electrode areas are wetted and the chest pulse sensor shuts off when it is removed and the electrode areas are dried. If the chest pulse sensor is not dried after each use, it may remain activated longer than necessary, draining the battery prematurely.
- Store the chest pulse sensor in a warm, dry place. Do not store the chest pulse sensor in a plastic bag or other container that may trap moisture.
- Do not expose the chest pulse sensor to direct sunlight for extended periods of time. Do not expose the chest pulse sensor to temperatures above 50° C (122° F) or below -10° C (14° F).
- Do not excessively bend or stretch the sensor unit when using or storing the chest pulse sensor.
- Clean the sensor unit using a damp cloth—never use alcohol, abrasives, or chemicals. The chest strap may be hand washed and air dried.

HOW TO CONNECT YOUR HOME STEREO

Note: If your stereo has an unused LINE OUT jack, see instruction A below. If the LINE OUT jack is being used, see instruction B.

- A. Plug one end of the audio cable into the jack beneath the console. Plug the other end of the audio cable into the adaptor. Plug the adaptor into the LINE OUT jack on your stereo.

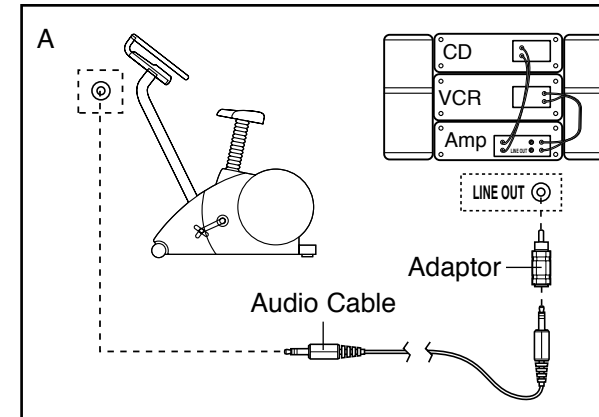

- B. Plug one end of the audio cable into the jack beneath the console. Plug the other end of the audio cable into the adaptor. Plug the adaptor into an RCA Y-adaptor (available at electronics stores). Next, remove the wire that is currently plugged into the LINE OUT jack on your stereo and plug the wire into the unused side of the Y-adaptor. Plug the Y-adaptor into the LINE OUT jack on your stereo.

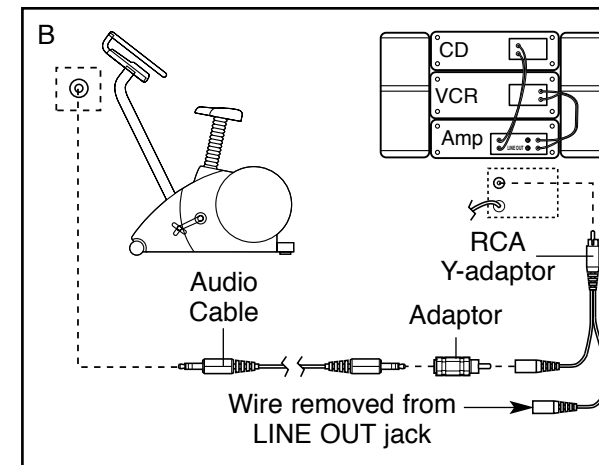

HOW TO CONNECT YOUR COMPUTER

Note: If your computer has a 3.5mm LINE OUT jack, see instruction A. If your computer has only a PHONES jack, see instruction B.

- A. Plug one end of the audio cable into the jack beneath the console. Plug the other end of the audio cable into the adaptor. Plug the adaptor into the LINE OUT jack on your computer.

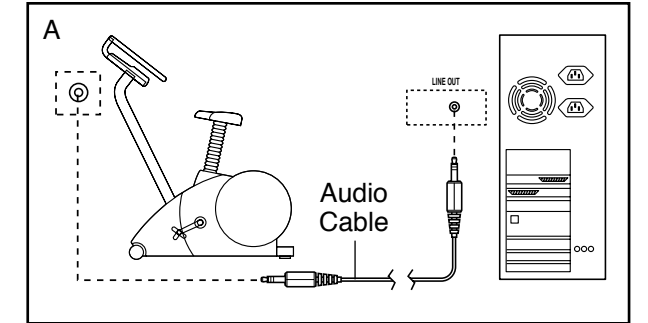

- B. Plug one end of the audio cable into the jack beneath the console. Plug the other end of the audio cable into the splitter. Plug the splitter into the PHONES jack on your computer. Plug your headphones or speakers into the other side of the splitter.

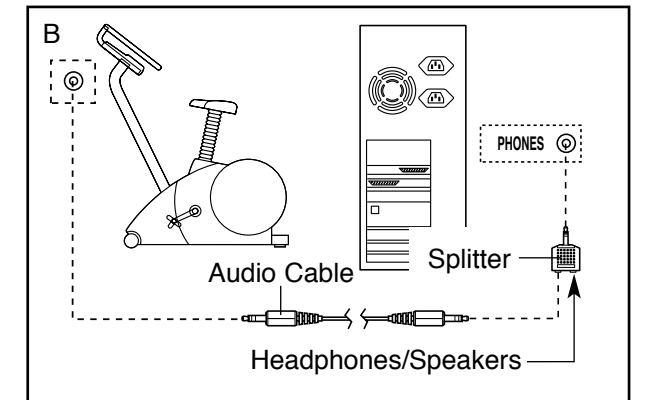

HOW TO CONNECT YOUR CD PLAYER, VCR, OR COMPUTER

To use iFIT.com CDs, the exercise cycle must be connected to your portable CD player, portable stereo, home stereo, or computer with CD player. See pages 18 and 19 for connecting instructions. To use iFIT.com video-cassettes, the exercise cycle must be connected to your VCR. See page 20 for connecting instructions. To use iFIT.com programs directly from our Web site, the exercise cycle must be connected to your home computer. See page 19 for connecting instructions.

HOW TO CONNECT YOUR PORTABLE CD PLAYER

Note: If your CD player has separate LINE OUT and PHONES jacks, see instruction A below. If your CD player has only one jack, see instruction B.

- A. Plug one end of the audio cable into the jack beneath the console. Plug the other end of the audio cable into the LINE OUT jack on your CD player. Plug your headphones into the PHONES jack.

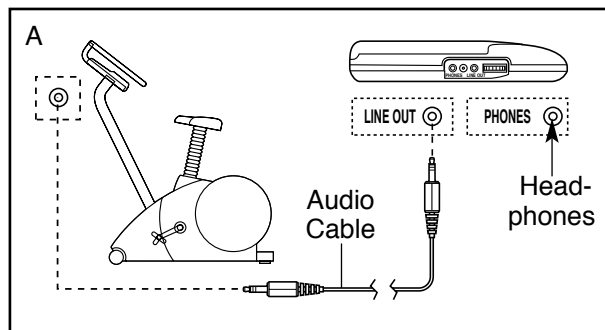

- B. Plug one end of the audio cable into the jack beneath the console. Plug the other end of the audio cable into the splitter. Plug the splitter into the PHONES jack on your CD player. Plug your headphones into the other side of the splitter.

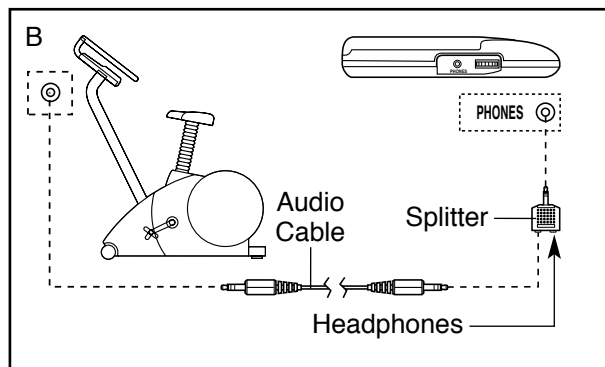

HOW TO CONNECT YOUR PORTABLE STEREO

Note: If your stereo has an RCA-type AUDIO OUT jack, see instruction A below. If your stereo has a 3.5mm LINE OUT jack, see instruction B. If your stereo has only a PHONES jack, see instruction C.

- A. Plug one end of the audio cable into the jack beneath the console. Plug the other end of the audio cable into the adaptor. Plug the adaptor into an AUDIO OUT jack on your stereo.

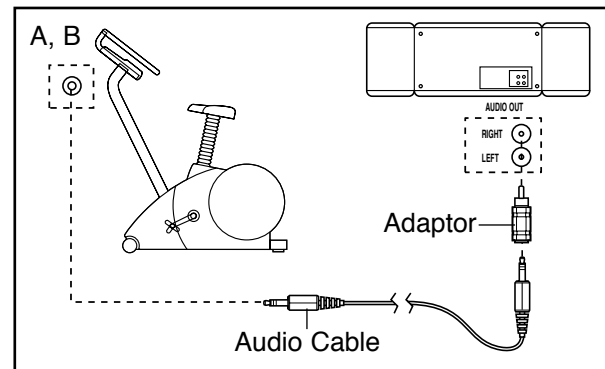

- B. See the drawing above. Plug one end of the audio cable into the jack beneath the console. Plug the other end of the audio cable into the LINE OUT jack on your stereo. Do not use the adaptor.

- C. Plug one end of the audio cable into the jack beneath the console. Plug the other end of the audio cable into the splitter. Plug the splitter into the PHONES jack on your stereo. Plug your headphones into the other side of the splitter.

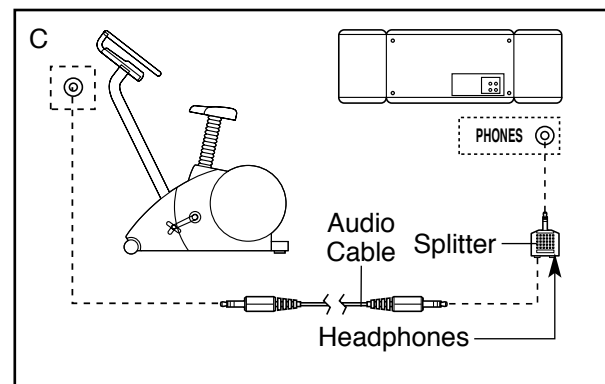

HOW TO OPERATE THE EXERCISE CYCLE

HOW TO MOVE AND LEVEL THE EXERCISE CYCLE

Stand in back of the exercise cycle, and lift the exercise cycle until it can be moved on the front wheels. Move the exercise cycle to the desired location and carefully lower it. Due to the weight of the exercise cycle, use extreme caution whilst moving it.

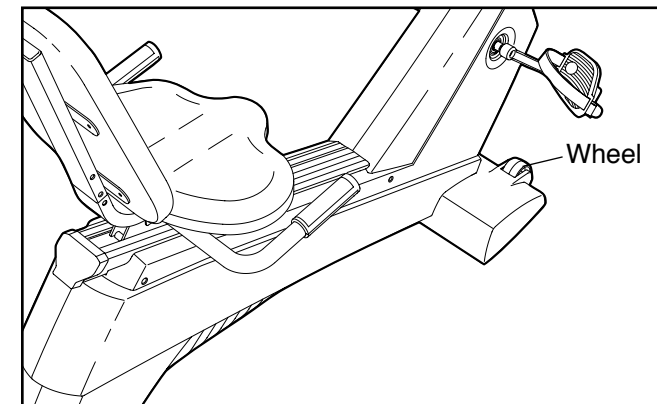

If the exercise cycle rocks slightly during use, turn the leveling feet under the rear stabiliser until the rocking motion is eliminated.

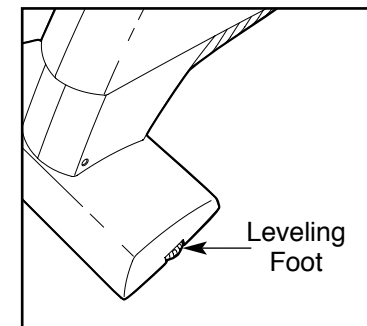

HOW TO ADJUST THE SEAT

The seat can be adjusted to the position that is the most comfortable for you. To adjust the seat, pull the seat knob, slide the seat forward or backward, and then release the seat knob. Move the seat forward or backward slightly until the pin on the seat knob snaps into one of the holes in the seat rail.

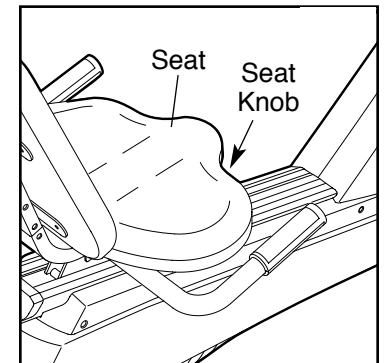

HOW TO ADJUST THE PEDAL STRAPS

The pedal straps can be adjusted to the position that is the most comfortable for you. Press the tabs on the pedals, adjust the straps to the desired position, and then release the tabs.

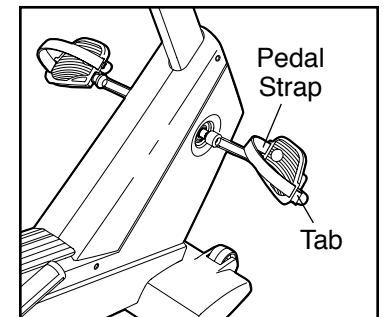

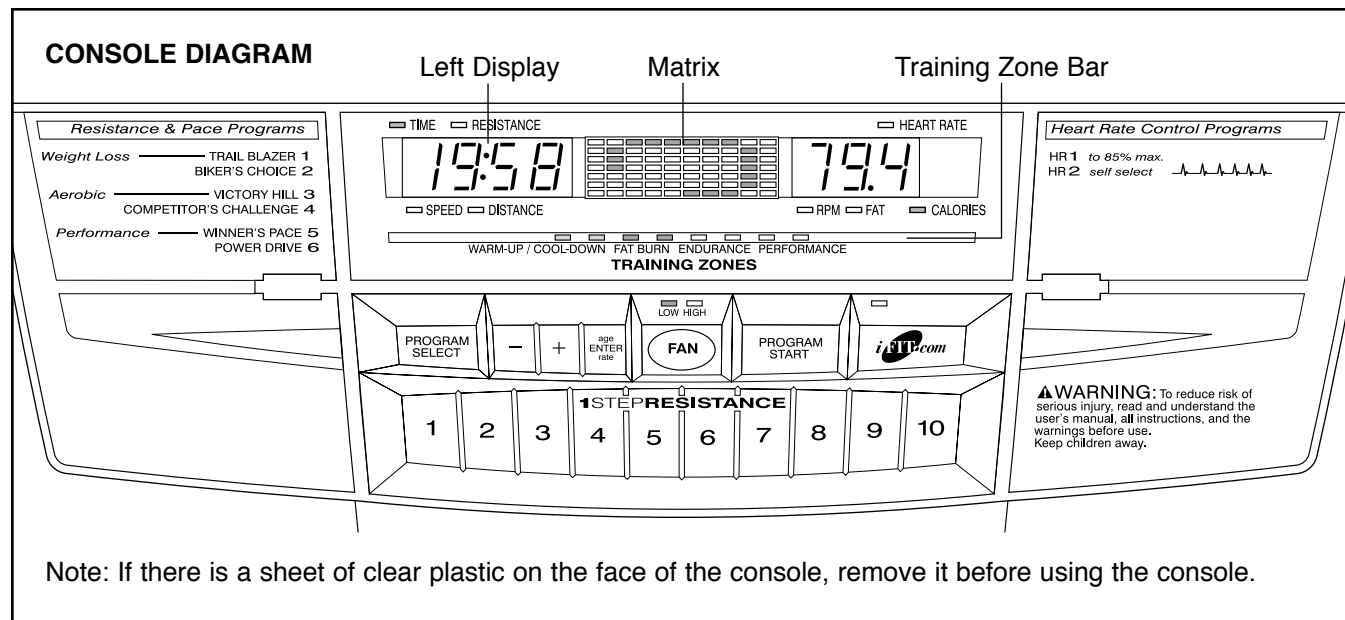

FEATURES OF THE CONSOLE

The advanced console offers a selection of features designed to make your workouts more enjoyable and effective. When the manual mode of the console is selected, the resistance of the exercise cycle can be changed with the touch of a button. As you exercise, the console will provide continuous exercise feedback. You can even measure your heart rate using the handgrip pulse sensor or the chest pulse sensor.

The console also offers six resistance and pace programs. Each program automatically changes the resistance of the exercise cycle and prompts you to increase or decrease your pace as it guides you through an effective workout.

In addition, the console features two heart rate programs that automatically change the resistance of the exercise cycle and prompt you to vary your pace to keep your heart rate near a target heart rate as you exercise.

The console also features iFIT.com interactive technology. Having iFIT.com interactive technology is like having a personal trainer in your home. Using the included audio cable, you can connect the exercise cycle to your home stereo, portable stereo, computer, or VCR and play special iFIT.com CD and video programs (iFIT.com CDs and videocassettes are available separately). iFIT.com CD and video programs automatically control the resistance of the exercise cycle and prompt you to vary your pace as a personal trainer coaches you through every step of your workout. High-energy music provides added motivation. **To purchase iFIT.com CDs and videocassettes, visit our Web site at www.iFIT.com.**

With the exercise cycle connected to your computer, you can also go to our Web site at www.iFIT.com and access programs directly from the internet. **Explore www.iFIT.com for more information.**

If you have selected heart rate program 2, the letters "PLS" and the current target heart rate setting will flash in the left display. Press the + or – button repeatedly to change the target heart rate setting, if desired. The target heart rate setting can be from 70 to 170 beats per minute.

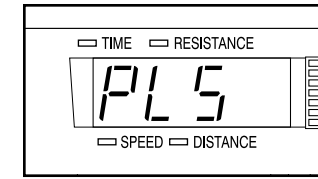

4 Hold the handgrip pulse sensor.

To use a heart rate program, you must wear the chest pulse sensor (see page 9) or use the handgrip pulse sensor (see step 5 on page 14). If you use the handgrip pulse sensor, it is not necessary to hold the handgrips continuously during the program. However, you should hold the handgrips frequently for the program to operate properly. **Each time you hold the handgrips, keep your hands on the metal contacts for at least 30 seconds.** Note: When you are not holding the handgrips, the letters "PLS" will appear in the right display instead of your heart rate.

5 Press the Program Start button or begin pedaling to start the program.

Heart rate program 1 consists of 20 one-minute segments. One resistance setting and one target heart rate setting are programmed for each segment. (The same resistance setting and/or target heart rate setting may be programmed for two or more consecutive segments.) During the program, the resistance of the exercise cycle will periodically change. **Heart rate program 2** is 40 minutes long (you may choose to use only part of the program). The same resistance setting and target heart rate setting are programmed for the entire program.

As you exercise, the Training Zone bar will help you to keep your heart rate near the target heart rate setting for the current segment. The lit indicators in the bar will show your actual pace. Whilst you wear the chest pulse sensor or hold

the handgrip pulse sensor, the console will periodically compare your heart rate to the target heart rate setting; if necessary, an indicator in the bar will then flash to prompt you to increase or decrease your pace to bring your heart rate closer to the target heart rate setting. If an indicator to the right of the lit indicators is flashing (see drawing a), increase your pace. If an indicator to the left of any lit indicator is flashing (see drawing b), decrease your pace. When no indicator is flashing, your heart rate is near the target heart rate setting. **Important: The target heart rate settings are intended only to provide motivation. Your actual heart rate may be slower than the target heart rate settings. Make sure to exercise at a pace that is comfortable for you.**

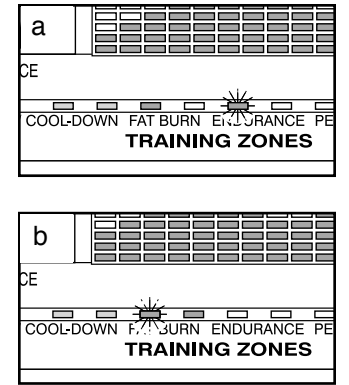

The program will continue until the resistance setting for the last segment is shown in the Current Segment column of the matrix and no time remains in the program.

Note: Heart rate programs cannot be stopped and then restarted. If you stop pedaling for several seconds, the program will end.

6 Monitor your progress with the two displays.

See step 4 on page 13.

7 Turn on the fan if desired.

See step 6 on page 14.

8 When the program is finished, the console will automatically turn off.

See step 7 on page 14.

4 Monitor your progress with the two displays.

See step 4 on page 13.

5 Measure your heart rate if desired.

See step 5 on page 14.

6 Turn on the fan if desired.

See step 6 on page 14.

7 When the program is finished, the console will automatically turn off.

See step 7 on page 14.

HOW TO USE HEART RATE PROGRAMS

Each heart rate program helps you to keep your heart rate near a certain percentage of your maximum heart rate during your workout. (Your maximum heart rate is estimated by subtracting your age from 220. For example, if you are 30 years old, your maximum heart rate is 190.) Heart rate program 1 is designed to keep your heart rate between 50% and 85% of your maximum heart rate whilst you exercise; heart rate program 2 is designed to keep your heart rate near a target heart rate that you choose.

Follow the steps below to use a heart rate program.

1 Begin pedaling to activate the console.

See step 1 on page 13.

2 Select one of the heart rate programs.

When the power is turned on, the manual mode will be selected. To select a heart rate program, press the Program Select button repeatedly until "H 1" or "H 2" appears in the right display.

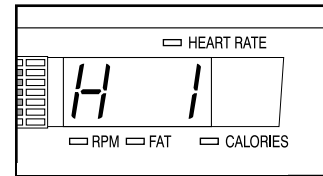

During heart rate programs, the matrix will show a graphic that represents your heart rate. Each time a heartbeat is detected, an additional peak will appear.

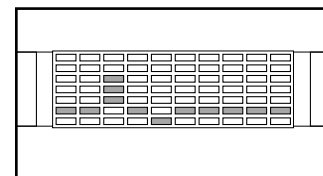

3 Enter your age or a target heart rate.

If you have selected heart rate program 1, the word "AGE" and the current age setting will flash in the left display. If you have already entered your age, press the Enter button and go to step 4. If you have not entered your age, press the + or - button repeatedly to enter your age, and then press the Enter button.

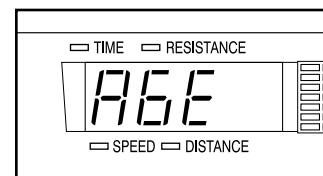

HOW TO USE THE MANUAL MODE

1 Begin pedaling to activate the console.

The exercise cycle requires no batteries or external power source. Power is supplied by a generator as you pedal. To activate the console, begin pedaling at a speed of about 3 miles per hour or faster. After a few seconds, the console displays will light. A tone will then sound and the console will be ready for use.

2 Select the manual mode.

When the power is turned on, the manual mode will be selected. If you have selected a program or the iFIT.com mode, reselect the manual mode by pressing the Program Select button repeatedly until a track appears in the matrix.

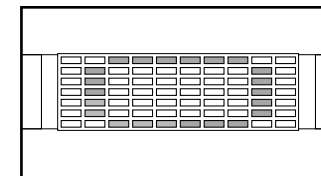

3 Begin pedaling and change the resistance of the exercise cycle as desired.

As you pedal, change the resistance of the exercise cycle by pressing the Resistance buttons. There are ten resistance levels. Note: After the Resistance buttons are pressed, it will take a moment for the exercise cycle to reach the selected resistance level.

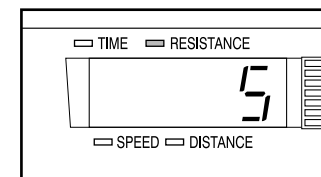

4 Monitor your progress with the matrix, the Training Zone bar, and the two displays.

The matrix— When the manual mode or the iFIT.com mode is selected, the matrix will show a

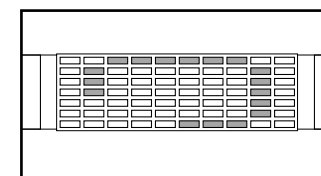

track representing 1/4 mile. As you exercise, the indicators around the track will light in succession until the entire track is lit. The track will then darken and the indicators will again begin to light in succession.

The Training Zone bar— The Training Zone bar will show your pace and the approximate intensity level of your exercise. For example, if three or four indicators in the bar are lit, the bar shows that your pace is ideal for fat burning. During programs, the Training Zone bar will also prompt you to increase or decrease your pace.

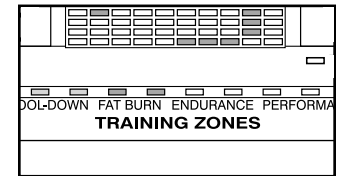

The left display— The left display will show your pedaling speed, the distance you have pedaled, the resistance level of the exercise

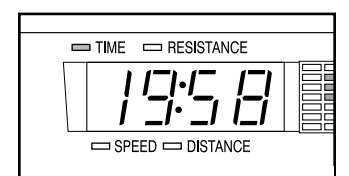

cycle, and the elapsed time. The display will change from one number to the next every few seconds, as shown by the indicators around the display. Note: Each time the resistance of the exercise cycle changes, the display will show the resistance level. When a program is selected, the display will show the time remaining in the program instead of the elapsed time.

The right display— The right display will show your pedaling pace (in revolutions per minute) and the approximate numbers of fat calories and calories you have burned (see FAT BURNING on page 24). The display will change from one number to the next every few seconds, as shown by the indicators. The display will also show your heart rate when you use the handgrip pulse sensor or the chest pulse sensor.

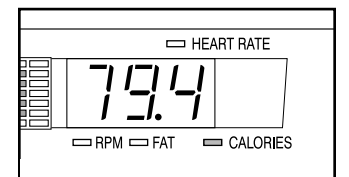

Note: The console can display speed and distance in either miles or kilometres. To find which unit of measurement is selected, you must select the console's user mode. Hold down the Program Select button for about three seconds. The letter "E" for English miles or the letter "M" for metric kilometres will appear in the left display. To change the unit of measurement, press the + button.

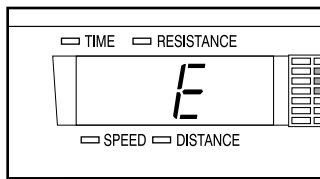

Whilst the user mode is selected, press the Program Start button. The left display will then show the total number of hours that the exercise cycle has been used. Press the Program Start button again. The left display will then show the total number of miles pedaled. To exit the user mode, press the Program Select button again.

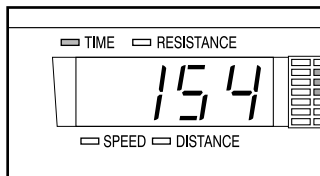

5 Measure your heart rate if desired.

To use the chest pulse sensor, see page 9. To use the handgrip pulse sensor, follow the instructions below. **Note: If you wear the chest pulse sensor and hold the handgrip pulse sensor at the same time, the console will not display your heart rate accurately.**

If there are thin sheets of plastic on the metal contacts on the handgrip pulse sensor, peel off the plastic. To measure your heart rate, hold the contacts; your palms must be resting on the upper contacts, and your fingers must be touching the lower contacts. **Avoid moving your hands.**

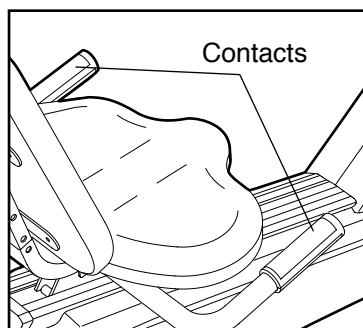

When your pulse is detected, the Heart Rate indicator above the right display will begin to flash, one or two dashes (—) will appear in the display, and then your heart rate will be shown. For the most accurate heart rate reading, hold the contacts for at least 15 seconds. Note: If you continue to hold the pulse sensor, the display will show your heart rate for up to 30 seconds. The display will then show your heart rate along with the other modes.

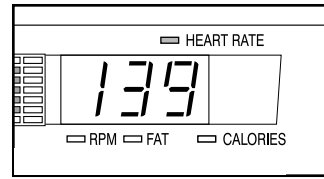

If your heart rate is not shown, make sure that your hands are positioned as described. Be careful not to move your hands excessively or to squeeze the metal contacts too tightly. For optimal performance, clean the metal contacts using a soft cloth; never use alcohol, abrasives, or chemicals.

6 Turn on the fan if desired.

To turn on the fan at low speed, press the Fan button. Pivot the fan to the desired angle. To turn on the fan at high speed, press the Fan button a second time. To turn off the fan, press the Fan button a third time. Note: If the pedals are not moved for about thirty seconds, the fan will automatically turn off.

7 When you are finished exercising, the console will automatically turn off.

If the pedals are not moved for several seconds, a tone will sound, the console will pause, and the left display will begin to flash.

If the pedals are not moved for about one minute, the console will turn off, but the displays will not be reset. If the pedals are not moved for about five minutes, the console will turn off and the displays will be reset.

HOW TO USE RESISTANCE AND PACE PROGRAMS

1 Begin pedaling to activate the console.

See step 1 on page 13.

2 Select one of the six resistance and pace programs.

When the power is turned on, the manual mode will be selected. To select a resistance and pace program, press the Program Select button repeatedly until "P 1," "P 2," "P 3," "P 4," "P 5," or "P 6" appears in the right display.

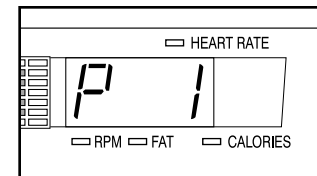

When a resistance and pace program is selected, the matrix will show the first seven target pace settings of the program. The left display will show how long the program will last.

3 Press the Program Start button or begin pedaling to start the program.

Each program is divided into several time segments of different lengths. One target pace setting and one resistance setting are programmed for each segment. (The same target pace setting and/or resistance setting may be programmed for two or more consecutive segments.)

The target pace setting for the first segment will be shown in the flashing Current Segment column of the matrix. (The resistance settings are not shown in the matrix.) The target pace settings for the next seven segments will be shown in the columns to the right.

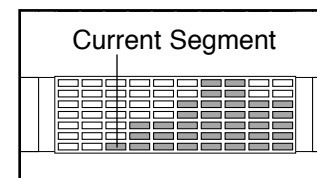

As you exercise, the Training Zone bar will help you to keep your pedaling pace near the target pace setting for the current segment. The lit indicators in the bar will show your actual pace. If an

indicator to the right of the lit indicators is flashing (see drawing a), increase your pace. If an indicator to the left of any lit indicator is flashing (see drawing b), decrease your pace. When no indicator is flashing, your pace matches the target pace setting. **Important: The target pace settings are intended only to provide motivation. Your actual pace may be slower than the target pace settings. Make sure to exercise at a pace that is comfortable for you.**

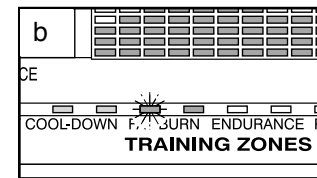
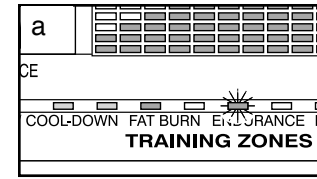

When only three seconds remain in the first segment of the program, both the Current Segment column and the column to the right will flash, a series of tones will sound, and all target pace settings will move one column to the left. The target pace setting for the second segment will then be shown in the flashing Current Segment column and the resistance of the exercise cycle will automatically change to the resistance setting for the second segment.

Note: If all of the indicators in the Current Segment column are lit after the target pace settings have moved to the left, the target pace settings will move downward so that only the highest indicators appear in the matrix.

The program will continue until the target pace setting for the last segment is shown in the Current Segment column of the matrix and no time remains in the program.

Note: During the program, you can override the resistance setting for the current segment, if desired, by pressing the Resistance buttons. However, when the next segment begins, the resistance will automatically change if a different resistance setting is programmed for the next segment. If you stop pedaling for several seconds, a tone will sound and the program will pause. To restart the program, simply resume pedaling.