



TKB_TZ65-D Z-Wave Dual Paddle Wall Dimmer



Firmware Version : 1.3

Quick Start

A This device is a Z-Wave actuator. To include the device into the network, turn the controller into the inclusion mode and then press the upper or lower part of the paddle of the device. The device is now ready to work.

Please refer to the chapters below for detailed information about all aspects of the products usage.

What is Z-Wave?

This device is equipped with wireless communication complying to the Z-Wave standard. Z-Wave is the **international standard for wireless communication** in smart homes and buildings. It is using the **frequency of 868.42 MHz** to realize a very stable and secure communication. Each message is reconfirmed (**two-way communication**) and every mains powered node can act as a repeater for other nodes (**meshed network**) in case the receiver is not in direct wireless range of the transmitter.

Z-Wave differentiates between Controllers and Slaves. Slaves are either sensors (**S**) transmitting metered or measured data or actuators (**A**) capable to execute an action. Controllers are either static mains powered controllers (**C**) also referred to as gateways or mobile battery operated remote controls (**R**). This results in a number of possible communication patterns within a Z-Wave network that are partly or completely supported by a specific device.

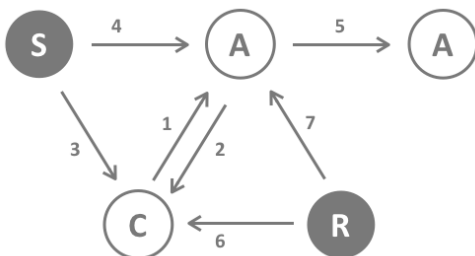

1. Controllers control actuators
2. Actuators report change of status back to controller
3. Sensors report change of status of measured values to controller

4. Sensors directly control actuators
5. Actuators control other actuators
6. Remote controls send signals to static controllers to trigger scenes or other actions
7. Remote controls control other actuators.

There are two different role a controller can have. There is always one single primary controller that is managing the network and including/excluding devices. The controller may have other functions - like control buttons - as well. All other controllers don't manage the network itself but can control other devices. They are called secondary controllers. The image also shows that its not possible to operate a sensor just from a remote control. Sensors only communicate with static controllers.

Product description

The TZ65-D dual wall switch is switching attached loads and is controlled either by the local switching paddle or remotely via the Z-Wave wireless protocol. It is included and controlled in a Z-Wave network by a remote control, a wireless control centre or any other kind of Z-Wave controller including a PC-software. Beside the local switch the unit can control other Z-Wave units remotely in up to three additional Z-Wave groups, which are associated with this device. Tipping one time or two times the switching paddle performs the control. The left paddle controls the local load while the right paddle remotely controls Z-Wave associated devices only. The association of further Z-Wave devices needs to be done by a Z-Wave controller. The unit is powered by 230V and needs a pattress box with 230 V power wires for installation.

The unit is shipped completely with electronics, switching paddle and mounting frame in arctic white HomePro style, which can be replaced by another mounting frame of the HomePro switching series. The unit is designed for use within a 3-wire system, which means that a neutral wire (blue) is needed for operations.

Attention: The Switch does not fit in a german 60mm pattress box!

Before Device is installed

Please read carefully the enclosed user manual before installation of the radio-actuator, in order to ensure an error-free functioning.

ATTENTION: only authorized technicians under consideration of the country-specific installation guidelines/norms may do works with 230?Volt mains power. Prior to the assembly of the product, the voltage network has to be switched off and ensured against re-switching.

The product is permitted only for proper use as specified in the user manual. Any kind of guarantee claim has to be forfeited if changes, modifications or painting are undertaken. The product must be checked for damages immediately after unpacking. In the case of damages, the product must not be operated in any case. If a danger-free operation of the equipment cannot be assured, the voltage supply has to be interrupted immediately and the equipment has to be protected from unintended operation.

Installation Guidelines

The TZ65-D wall mounted dimmer needs a pattress box with 230 V power wires for installation. It does not fit into European wall boxes with 60 mm diameter.

1. To install the wall dimmer first remove the paddle using a small screw driver.
2. Afterwards remove the four screws through the retaining ring holding the trim ring to the mounting plate. This will allow the removal of the trim ring. When removing the trim ring make sure not to bend or disrupt the shape of the antenna wire.
3. Wire the product according to the schematics. The two wires from the mains distribution panel are directly connected to the inserts contacts **N** and **L**. The contact **L'** is the switched load output and needs to be connected to the cable of the load.
4. Install the product in the wall box.
5. Reinstall the trim ring and the retaining ring with the four screws. Mind the arrow on the inserts top side showing the mounting direction of the insert.
6. Return the switching paddle by pushing it into the mounting frame. Make sure the LED window is also towards the stamped word "Bottom" on the retaining ring.

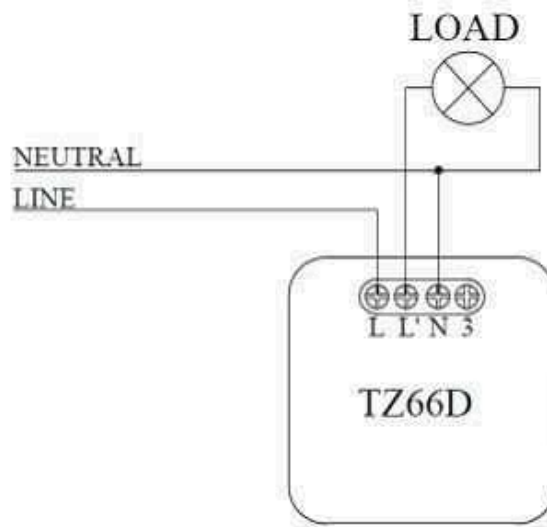

Behavior within the Z-Wave network

I On factory default the device does not belong to any Z-Wave network. The device needs to join an existing wireless network to communicate with the devices of this network. This process is called **Inclusion**. Devices can also leave a network. This process is called **Exclusion**. Both processes are initiated by the primary controller of the Z-Wave network. This controller will be turned into exclusion respective inclusion mode. Please refer to your primary controllers manual on how to turn your controller into inclusion or exclusion mode. Only if the primary controller is in inclusion or exclusion mode, this device can join or leave the network. Leaving the network - i.e. being excluded - sets the device back to factory default.

If the device already belongs to a network, follow the exclusion process before including it in your network. Otherwise inclusion of this device will fail. If the controller being included was a primary controller, it has to be reset first.

The device is included and excluded by a single click on the switch when the controller is in inclusion resp. exclusion mode.

Operating the device

The actuator can be set to control other Z-Wave devices and is operated by the local switching paddles or wirelessly using Z-Wave commands. The left paddle controls the local load while the right paddle remotely controls Z-Wave associated devices only. If the insert is mounted correctly pushing the upper part of the left or right paddle will turn ON the load. Pushing the lower part of the left or right paddle will turn OFF the electric load. Pressing and holding the switch will allow dimming and brightening of Z-Wave dimmers if associated.

LED Control

The LED on the TZ65-D will turn on when the load attached is off, to act as a night light. However, the LED can be user configured to turn on when the load attached is on.

The TZ65-D will flicker its LED when it is transmitting to any of its 4 groups. This can be changed if desired. See "LED transmission indication".

Associations

A Z-Wave devices control other Z-Wave devices. The relationship between one device controlling another device is called *association*. In order to control a different device, the controlling device needs to maintain a list of devices that will receive controlling commands. These lists are called **association groups** and they are always related to certain events (e.g. button pressed, sensor triggers, ...). In case the event happens all devices stored in the respective association group will receive a common wireless command.

Association Groups:

1	Tap left paddle once (max. nodes in group: 5)
2	Tap right paddle once (max. nodes in group: 5)
3	Tap right paddle twice (max. nodes in group: 5)
4	every switching command (max. nodes in group: 5)

Configuration Parameters

Z-Wave products are supposed to work out of the box after inclusion, however certain configuration can adapt the function better to user needs or unlock further enhanced features.

IMPORTANT: Controllers may only allow to configure signed values. In order to set values in the range 128 ... 255 the value sent in the application shall be the desired value minus 256. For example: to set a parameter to 200? it may be needed to set a value of 200 minus 256 = minus 56. In case of two byte value the same logic applies: Values greater than 32768 may needed to be given as negative values too.

Start Level Bit (Parameter Number 1, Parameter Size 1) defines if the start level bit shall be ignores when transmitting a dim command to a dimmer

Value	Description
0	ignore
1	dont ignore (Default)

Suspend Group 4 (Parameter Number 2, Parameter Size 1) defines if the Association group 4 shall be active or not

Value	Description
0	yes (Default)
1	no

Night Light (Parameter Number 3, Parameter Size 1) Activates Night Light

Value	Description
0	LED blinks on activity (Default)
1	Night Light active

Invert Switch (Parameter Number 4, Parameter Size 1) Inverts Switching (on is upper part)

Value	Description
0	dont invert (Default)
1	invert

Enable Shade Control Group 2 (Parameter Number 14, Parameter Size 1) The device can operate shade control devices via Group 2 if this parameter is activated

Value	Description
0	inactive (Default)
1	active

Enable Shade Control Group 3 (Parameter Number 15, Parameter Size 1) The device can operate shade control devices via Group 3 if this parameter is activated

Value	Description
0	inactive (Default)
1	active

LED Transmission Indication (Parameter Number 19, Parameter Size 1) defines the behavior of the LED when transmitting data

Value	Description
0	no flicker (Default)
1	flicker all time of data transmission
2	flicker for one second only

Poll Group 2 Interval (Parameter Number 20, Parameter Size 1) defines the poll interval for group 2 if polling is activated

Value	Description
1 — 255	Interval (Default 2)

Poll Group 2 (Parameter Number 22, Parameter Size 1) defines if Group 2 shall be polled or not

Value	Description
0	dont poll
1	poll (Default)

Command Classes

Supported Command Classes

Basic (version 1)

Association (version 1)

Version (version 1)

All Switch (version 1)

Configuration (version 1)

Manufacturer Specific (version 1)

Multilevel Switch (version 1)

Technical Data

Power Supply	230V
Attachable Loads	ohmic loads up to 300 W
IP Rating	IP 20
Frequency	868.42 MHz
Wireless Range	
Explorer Frame Support	Yes
SDK	4.54.00
Device Type	Slave with routing capabilities
Generic Device Class	Multilevel Switch
Specific Device Class	Multilevel Power Switch
Routing	Yes
FLiRS	No
Firmware Version	1.3

Explanation of Z-Wave specific terms

Controller — is a Z-Wave device with capabilities to manage the network. Controllers are typically Gateways, Remote Controls or battery operated wall controllers.

Slave — is a Z-Wave device without capabilities to manage the network. Slaves can be sensors, actuators and even remote controls.

Primary Controller — is the central organizer of the network. It must be a controller. There can be only one primary controller in a Z-Wave network.

Inclusion — is the process of bringing new Z-Wave devices into a network.

Exclusion — is the process of removing Z-Wave devices from the network.

Association — is a control relationship between a controlling device and a controlled device.

WakeUp Notification — is a special wireless message issued by a Z-Wave device to announces that is is able to communicate.

Node Information Frame — is a special wireless message issued by a Z_Wave device to announce its capabilities and functions.

Disposal Guidelines

The product does not contain hazardous chemicals.

Do not dispose of electrical appliances as unsorted municipal waste, use separate collection facilities. Contact your local government for information regarding the collection systems available. If electrical appliances are disposed of in landfills or dumps, hazardous substances can leak into the groundwater and get into the food chain, damaging your health and well-being.