

Kramer Electronics, Ltd.



USER MANUAL

Model:

TBUS-1A

Table Connection Bus

Contents

1	Introduction	1
2	Getting Started	1
2.1	Quick Start	1
3	Overview	3
4	Your TBUS-1A Table Connection Bus	4
5	Installing the TBUS-1A Table Connection Bus	6
5.1	Cutting an Opening in the Table	6
5.2	Installing the Required Wall Plates	7
5.3	Adjusting the Height of the Connecting Surface	7
5.4	Inserting the TBUS-1A through the Cut-Out Opening	7
5.5	Installing the Cables	8
6	Using the TBUS-1A	9
7	Technical Specifications	10

Figures

Figure 1:	TBUS-1A inside a Table	3
Figure 2:	TBUS-1A Table Connection Bus Top View	4
Figure 3:	TBUS-1A Connecting Surface	5
Figure 4:	Cutout Dimensions	6
Figure 5:	Inserting TBUS-1A into the Prepared Opening	8
Figure 6:	TBUS-1A Boardroom Installation	9

Tables

Table 1:	TBUS-1A Table Connection Bus Features	4
Table 2:	TBUS-1A Connecting Surface Features	5
Table 3:	Technical Specifications of the TBUS-1A	10

1 Introduction

Welcome to Kramer Electronics! Since 1981, Kramer Electronics has been providing a world of unique, creative, and affordable solutions to the vast range of problems that confront the video, audio, presentation, and broadcasting professional on a daily basis. In recent years, we have redesigned and upgraded most of our line, making the best even better! Our 1,000-plus different models now appear in 11 groups¹ that are clearly defined by function.

Thank you for purchasing the Kramer **TBUS-1A** *Table Connection Bus*, which is ideal for boardrooms, conference and training rooms!

The package includes the following items:

- **TBUS-1A** *Table Connection Bus*
- 2 table clamps
- Power cord²
- 6 self-locking ties
- Metal template³
- This user manual⁴

2 Getting Started

We recommend that you:

- Unpack the equipment carefully and save the original box and packaging materials for possible future shipment
- Review the contents of this user manual
- Use Kramer high-performance high-resolution cables⁵

2.1 Quick Start

This quick start chart summarizes the basic setup and operation steps.

1 GROUP 1: Distribution Amplifiers; GROUP 2: Switchers and Matrix Switchers; GROUP 3: Control Systems; GROUP 4: Format/Standards Converters; GROUP 5: Range Extenders and Repeaters; GROUP 6: Specialty AV Products; GROUP 7: Scan Converters and Scalers; GROUP 8: Cables and Connectors; GROUP 9: Room Connectivity; GROUP 10: Accessories and Rack Adapters; GROUP 11: Sierra Products

2 We recommend that you use only the power cord supplied with this device

3 In addition to the cardboard template (provided), an optional metal template is available for order

4 Download up-to-date Kramer user manuals from our Web site: <http://www.kramerelectronics.com>

5 The complete list of Kramer cables is on our Web site at <http://www.kramerelectronics.com>

Step 1: Mount the machine - see section 5.1

Cut out an opening in your table according to the cutout template

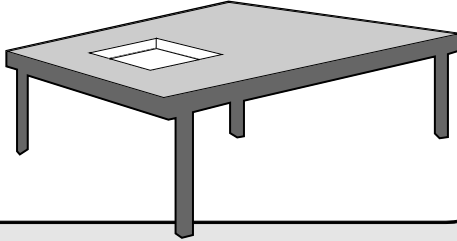

Step 2: Connect the modular wall plate items - see section 5.2

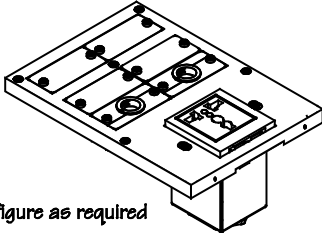

Configure as required

Step 3: Adjust the height of the Connecting Surface - see section 5.3

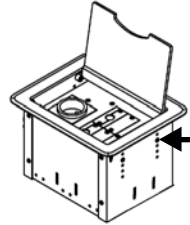

Step 4: Insert the unit - see section 5.4

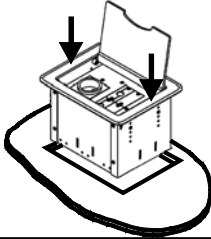

Step 5: Secure the unit to the table - see section 5.4

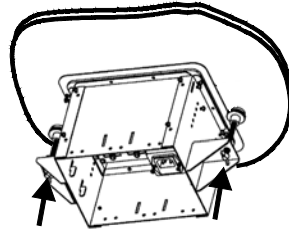

Step 6: Insert the cables - see section 5.5

Secure the unit and lock it in place

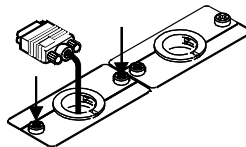

3 Overview

The **TBUS-1A** is a furniture-mounted connection bus that is easily installed into a table or podium top. The **TBUS-1A** lets you connect any equipment to the room's presentation system installations via cable access or passive interfaces (see [Figure 1](#)). When the cables are not in use, they can be stored inside the unit, covered by the lid and out of sight.

In addition, the **TBUS-1A** features:

- Modular design, letting you tailor it according to your needs¹
- One power socket - available in 7 versions: USA, UK, Germany-EU, Belgium-France, South Africa, Australia, and "Universal" (for general use²)
- A black-textured lid with a special opening for cable pass-through

To achieve the best performance:

- Connect only good quality connection cables, thus avoiding interference, deterioration in signal quality due to poor matching, and elevated noise levels (often associated with low quality cables)
- Avoid interference from neighboring electrical appliances that may adversely influence signal quality and position your Kramer **TBUS-1A** away from moisture, excessive sunlight and dust



Figure 1: TBUS-1A inside a Table

¹ The complete list of Kramer wall plate devices, for designing the Connecting Surface, can be found on our Web site at <http://www.kramerelectronics.com>

² See compatibility restrictions in the Specification section [7](#)

4 Your TBUS-1A Table Connection Bus

[Figure 2](#) and [Table 1](#) define the TBUS-1A unit:

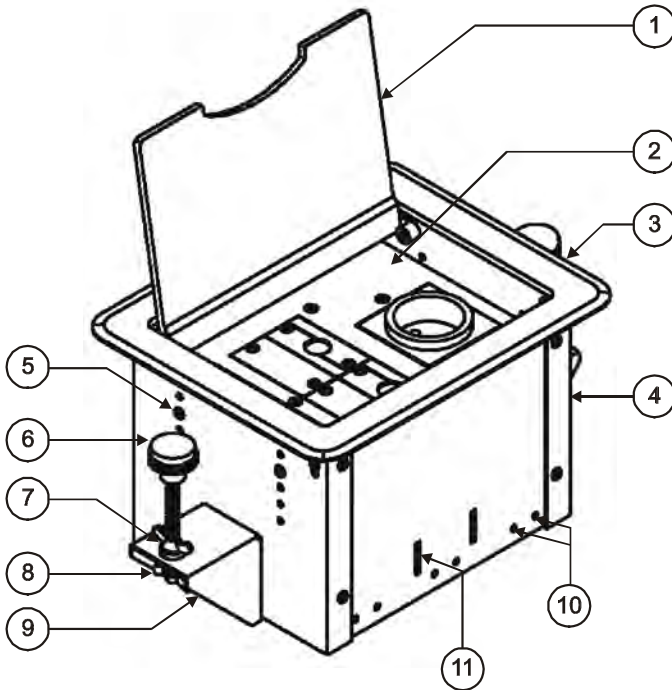

Figure 2: TBUS-1A Table Connection Bus Top View

Table 1: TBUS-1A Table Connection Bus Features

#	Feature	Function
1	Connec ing Surface	See Figure 3 and Table 2
2	Black Textured Lid	Has an opening for cable pass-through; covers the Connec ing Surface, leaving the table surface neat and tidy
3	Outer Rim	Fits over the table surface
4	Enclosure	Inserted into the table cutout
5	Height Adjustment Screws	10 screws on each side panel for adjusting the height of the Connecting Surface
6	Rubber Protectors	Protect the table surface when moun ing the unit (one on each side)
7	Locking Butterfly Screws	Tighten to lock the mounting butterfly screw (one on each side)
8	Mounting Butterfly Screws	Tighten to secure the unit to the table surface (one on each side)

Your TBUS-1A Table Connection Bus

#	Feature	Function
9	Mounting Brackets (2 units)	Place in the bracket slits after inserting the enclosure into the table – for securing the unit to the table surface (one on each side)
10	Tie Holes ¹	Insert the self-locking tie, through the holes to fix the pass-through cables to the inside walls of the unit (6 pairs of holes, 3 for the front panel and 3 for the rear panel)
12	Bracket Slits	Located on the front and rear panels, and on both sides of the unit. For attaching the two mounting brackets on opposite sides

[Figure 3](#) and [Table 2](#) define the Connecting Surface:

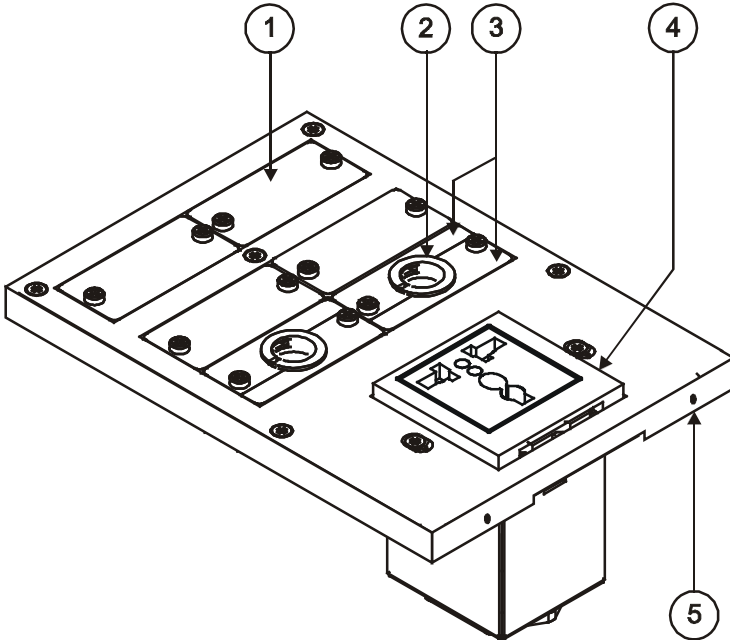

Figure 3: TBUS-1A Connecting Surface

Table 2: TBUS-1A Connecting Surface Features

#	Feature	Function
1	Blank Plates	Four blank covers that can be replaced with wall plates as required
2	Split Grommets	Push apart slightly to insert cables
3	Split Brackets	Support the split grommet for the pass through-cables
4	Universal Power Socket	Suitable for international power requirements
5	Adjustable Height Screw Holes	For adjusting the height of the Connecting Surface

¹ Some versions may not include tie holes

5 Installing the TBUS-1A Table Connection Bus

To install the **TBUS-1A** perform the following steps:

1. Cut an opening in the table (see section [5.1](#)).
2. Mount the required wall plate items (see section [5.2](#)).
3. Set the height of the Connecting Surface (see section [5.3](#)).
4. Insert the unit through the hole and secure to the table (see section [5.4](#)).
5. Connect the cables (see section [5.5](#)).

5.1 Cutting an Opening in the Table

To cut an opening in the table:

1. Place the included cut-out template on the surface of the table where you want to install **TBUS-1A**.
2. Attach the template to the table with the included screws (if using the optional metal template.)
3. Following the inside edge of the template, cut a hole in the table surface with a sabre or keyhole saw according to the dimensions shown in [Figure 4](#) (not to scale).

Note: The thickness of the table should be 3 inches or less.

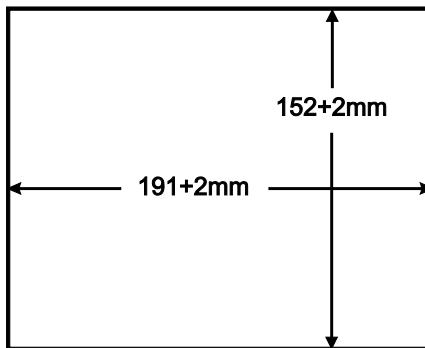

Figure 4: Cutout Dimensions

4. Remove the template from the surface of the table and clean the table surface.
Take care not to damage the table.
If needed, you can download a full-scale template from our Web site¹.

¹ At <http://www.kramerelectronics.com>

Kramer Electronics is not responsible for any damage caused to the table

5.2 Installing the Required Wall Plates

By default, the mounting surface includes a universal power supply, two cable pass-through plates and four blank plates for optional video, audio, telephone and network connectors.

Any of the plates mounted to the Connecting Surface can be rearranged or removed and replaced with Kramer passive wall plates¹ or connector modules for interfacing A/V type signals.

To mount a Kramer insert or connector module, do the following:

1. Unscrew the two screws that fasten the blank plate to the connecting surface and remove the blank plate.
2. Place the required Kramer insert over the opening, insert the two screws to fix the Kramer insert in place, and tighten them.

5.3 Adjusting the Height of the Connecting Surface

If needed, you can adjust the connecting surface to one of four possible heights to accommodate large or bulky cables. By default, the height is set to the second level from the top. To adjust, perform the following:

1. Remove the height adjustment screws, while supporting the surface from underneath with your fingers.
2. Use your fingers to bring the Connecting Surface to the required height, screw and tighten it in place using the height adjustment screws.

5.4 Inserting the TBUS-1A through the Cut-Out Opening

To install **TBUS-1A** in the opening:

1. Carefully insert the unit into the prepared opening (see [Figure 5](#)).
2. Take the support brackets under the table and place them into the support bracket grooves on both sides of the unit (see [Figure 2](#)).
3. Verify proper alignment of the unit before tightening the mounting screws.

¹ The complete list of Kramer wall plates and module connectors is on our Web site at <http://www.kramerelectronics.com>

4. Screw both mounting butterfly screws upward until they reach the table surface (from underneath). Tighten firmly (see [Figure 5](#)).
5. Screw the locking butterfly screws downward until tight against the mounting bracket.

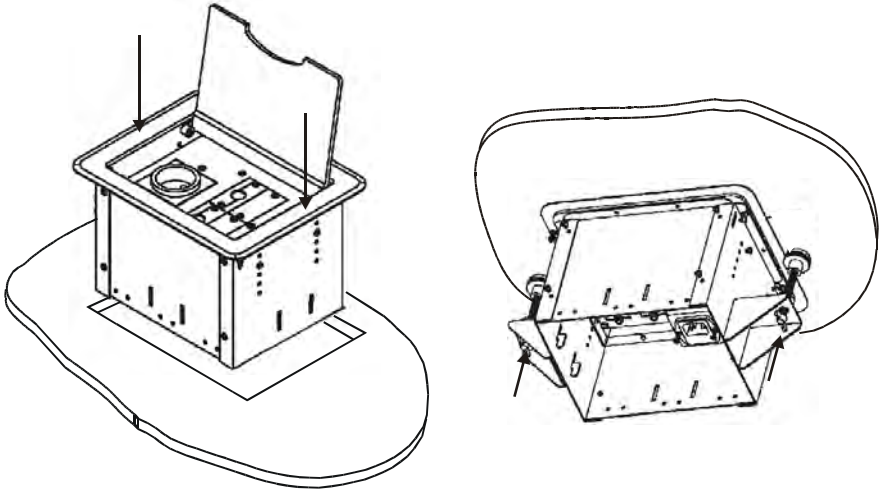

Figure 5: Inserting TBUS-1A into the Prepared Opening

5.5 Installing the Cables

To insert the pass through cables (for example, to connect a laptop) do the following:

1. Remove the two screws attaching the split pass-through bracket.
2. Remove the split grommet.
3. Insert the cable through the rectangular opening.
4. Open the split grommet slightly and insert the required cables.
5. Place the split bracket around the grommet and position this assembly over the Connecting Surface frame.
6. Place the two screws appropriately and tighten the split bracket together with the grommet and inserted cables to the Connecting Surface.
7. Insert the self-locking ties through the tie holes to secure the cables to the inside walls of the enclosure.

6 Using the TBUS-1A

Once the **TBUS-1A** is installed, you can easily customize it to your own needs by plugging in the required A/V equipment, as illustrated in the example in [Figure 6](#).

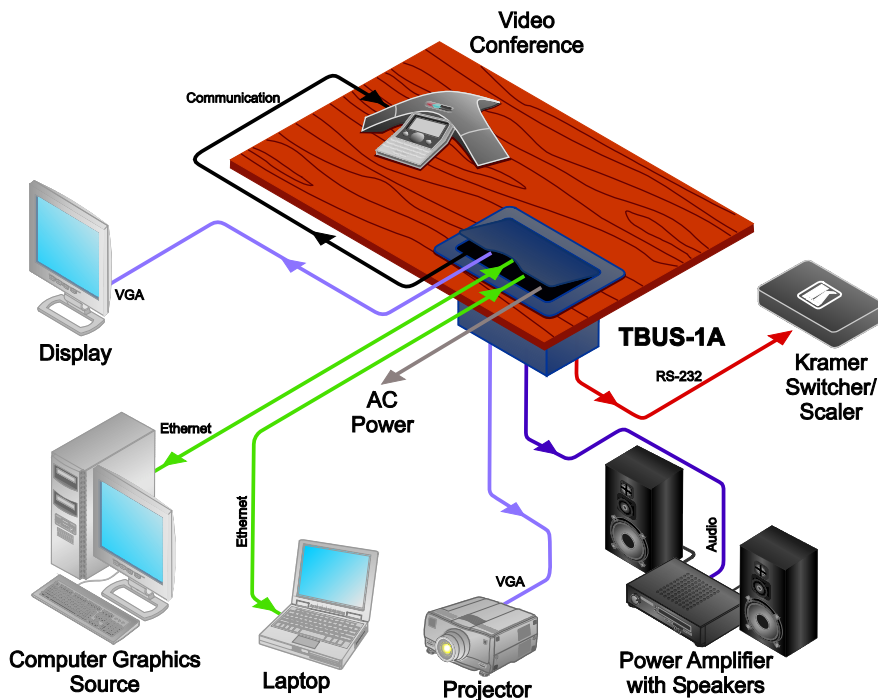

Figure 6: TBUS-1A Boardroom Installation

7 Technical Specifications

[Table 3](#) includes the technical specifications:

Table 3: Technical Specifications¹ of the TBUS-1A

POWER SOURCE (AC power limits):	Universal ^{2 3 4}	100-240V AC, 50/60Hz, 5A
	USA	100-240V AC, 50/60Hz, 5A
	UK	100-240V AC, 50/60Hz, 5A
	Germany and EU	100-240V AC, 50/60Hz, 5A
	Belgium and France	100-240V AC, 50/60Hz, 5A
	South Africa	100-240V AC, 50/60Hz, 5A
	Australia	100-240V AC, 50/60Hz, 5A
FUSE RATING:	T 6.3A 250V	
OPERATING TEMPERATURE RANGE:	+5 to +45 Deg. Centigrade	
OPERATING HUMIDITY RANGE:	10 to 90% RHL, non-condensing	
STORAGE TEMPERATURE RANGE:	-20 to +70Deg. C.	
STORAGE HUMIDITY RANGE:	5 to 95% RHL, non-condensing	
DIMENSIONS:	20.5cm x 17cm x 13.2cm (8.07" x 6.69" x 5.20") W, D, H	
WEIGHT:	TBUS-1A: 1.5kg (3.3lbs) approx. Table clamps: 0.26kg (0.57lbs) Metal template: 0.125kg (0.28lbs)	
ACCESSORIES:	Power cord, six self-locking ties, metal template	
OPTIONS:	Passive wall plates and interfaces	

¹ Specifications are subject to change without notice

² The Universal socket is fully compatible with power plugs in UK, India, Italy, Denmark and the 2-prong Europlug

³ The Universal socket is partially compatible (polarity is reversed) with plugs in China, Switzerland, Israel and USA The Universal socket does not supply grounding to plugs in Central Europe and France Order country specific sockets instead

⁴ The Universal socket does not fit South African plugs

LIMITED WARRANTY

Kramer Electronics (hereafter *Kramer*) warrants this product free from defects in material and workmanship under the following terms

HOW LONG IS THE WARRANTY

Labor and parts are warranted for seven years from the date of the first customer purchase

WHO IS PROTECTED?

Only the first purchase customer may enforce this warranty

WHAT IS COVERED AND WHAT IS NOT COVERED

Except as below, this warranty covers all defects in material or workmanship in this product. The following are not covered by the warranty:

- 1 Any product which is not distributed by Kramer, or which is not purchased from an authorized Kramer dealer. If you are uncertain as to whether a dealer is authorized, please contact Kramer at one of the agents listed in the Web site www.kramerelectronics.com
- 2 Any product, on which the serial number has been defaced, modified or removed, or on which the WARRANTY VOID IF TAMPERED sticker has been torn, reattached, removed or otherwise interfered with
- 3 Damage, deterioration or malfunction resulting from:
 - i) Accident, misuse, abuse, neglect, fire, water, lightning or other acts of nature
 - ii) Product modification, or failure to follow instructions supplied with the product
 - iii) Repair or attempted repair by anyone not authorized by Kramer
 - iv) Any shipment of the product (claims must be presented to the carrier)
 - v) Removal or installation of the product
 - vi) Any other cause, which does not relate to a product defect
 - vii) Cartons, equipment enclosures, cables or accessories used in conjunction with the product

WHAT WE WILL PAY FOR AND WHAT WE WILL NOT PAY FOR

We will pay labor and material expenses for covered items. We will not pay for the following:

- 1 Removal or installations charges
- 2 Costs of initial technical adjustments (set-up), including adjustment of user controls or programming. These costs are the responsibility of the Kramer dealer from whom the product was purchased
- 3 Shipping charges

HOW YOU CAN GET WARRANTY SERVICE

- 1 To obtain service on your product, you must take or ship it prepaid to any authorized Kramer service center
- 2 Whenever warranty service is required, the original dated invoice (or a copy) must be presented as proof of warranty coverage, and should be included in any shipment of the product. Please also include in any mailing a contact name, company, address, and a description of the problem(s)
- 3 For the name of the nearest Kramer authorized service center, consult your authorized dealer

LIMITATION OF IMPLIED WARRANTIES

All implied warranties, including warranties of merchantability and fitness for a particular purpose, are limited in duration to the length of this warranty

EXCLUSION OF DAMAGES

The liability of Kramer for any effective products is limited to the repair or replacement of the product at our option. Kramer shall not be liable for:

- 1 Damage to other property caused by defects in this product, damages based upon inconvenience, loss of use of the product, loss of time, commercial loss; or
- 2 Any other damages, whether incidental, consequential or otherwise. Some countries may not allow limitations on how long an implied warranty lasts and/or do not allow the exclusion or limitation of incidental or consequential damages, so the above limitations and exclusions may not apply to you

This warranty gives you specific legal rights, and you may also have other rights, which vary from place to place

NOTE: All products returned to Kramer for service must have prior approval. This may be obtained from your dealer

This equipment has been tested to determine compliance with the requirements of:

- EN-50081: "Electromagnetic compatibility (EMC);
generic emission standard
Part 1: Residential, commercial and light industry"
- EN-50082: "Electromagnetic compatibility (EMC) generic immunity standard
Part 1: Residential, commercial and light industry environment"
- CFR-47:
FCC* Rules and Regulations:
Part 15: "Radio frequency devices
Subpart B Unintentional radiators"

CAUTION!

- Servicing the machines can only be done by an authorized Kramer technician. Any user who makes changes or modifications to the unit without the expressed approval of the manufacturer will void user authority to operate the equipment
- Use the supplied DC power supply to feed power to the machine
- Please use recommended interconnection cables to connect the machine to other components
* FCC and CE approved using STP cable (for twisted pair products)



For the latest information on our products and a list of Kramer distributors, visit our Web site: www.kramerelectronics.com where updates to this user manual may be found. We welcome your questions, comments and feedback.



Caution

Safety Warning:

Disconnect the unit from the power supply before opening/servicing.



Kramer Electronics, Ltd.

Web site: www.kramerelectronics.com

E-mail: info@kramereel.com

P/N: 2900-000696 REV 3