



KING || FLEX™

Portable Automatic Satellite TV Antenna



VQ2100
Owner's Manual

KING™

11200 Hampshire Avenue South, Bloomington, MN 55438
PH 952.922.6889 || FAX 952.922.8424 || kingcontrols.com

IMPORTANT!

The satellite TV market is expanding and changing. The information in this manual was accurate at the time of printing. If your KING™ Flex® Portable Satellite Antenna does not operate as outlined in this manual, please call KING at (952) 922-6889 or visit our website at www.kingcontrols.com. KING is not responsible for changes outside of its control.

Please read the appropriate sections of this manual before using your new KING Flex.

Please record the
Purchase Date and Serial Number
of your KING Flex below...

...and then go to the section for
your satellite service provider.

ENJOY!

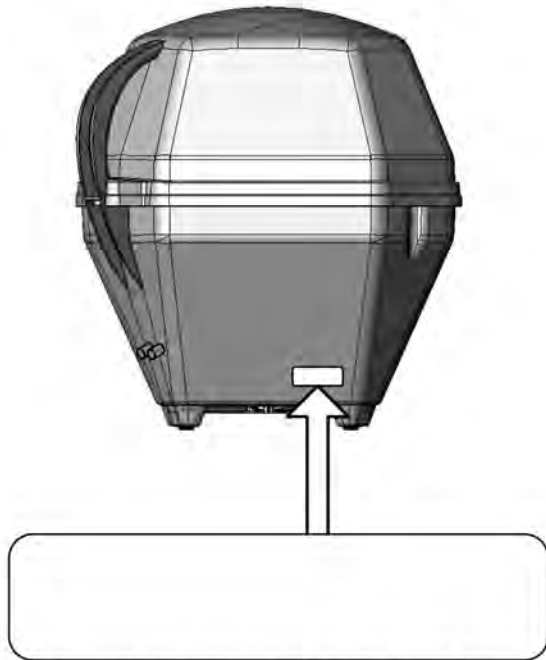

Record your serial number here.

PURCHASE DATE

____ / ____ / ____
Month / Day / Year

Bell TV is an official trademark of Bell Canada.
DIRECTV is a registered trademark of DIRECTV, Inc.
HDMI is a registered trademark of HDMI Licensing L.L.C.
DISH and Tailgater are registered trademarks of DISH Network L.L.C.
KING and KING Flex are trademarks of Electronic Controlled Systems.

DIRECTV® Customers

DIRECTV

DISH® Customers

DISH

BELL TV™ Customers

BELL TV

Helpful Information

APPENDIX

DIRECTV

THANK YOU for your purchase of the **KING Flex Portable Automatic Satellite TV Antenna!**

The KING Flex portable satellite antenna will easily lock onto the appropriate satellites necessary to receive your favorite SD programming from DIRECTV.

DIRECTV subscribers, please use the information in this section to operate your system. You will also find helpful information on troubleshooting, security, the warranty, and KING Flex mounting brackets in the Appendix at the end of this manual.

Section 1

SETUP

Pages 2-3

Section 2

ANTENNA AND ALARM CONFIGURATION

Pages 4-5







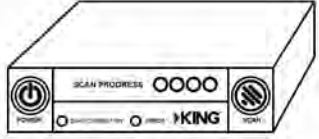
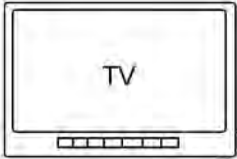

Section 3

OPERATION

Pages 6-7

DIRECTV 

1 Make sure you have everything you need.

Included with KING Flex		Sold Separately	
	 Controller		 Receiver to TV cable(s)
 50' Coax	 Power Supply	 Receiver	
 3' Coax	 Quick Reference Guide	DIRECTV Programming Subscription	
	 Owner's Manual	<p>The KING Flex will not work with DIRECTV SWM only receivers.</p> <p>Do not use dual tuner receivers or receivers with built-in recorders if your programming is broadcast from more than one satellite.</p>	

2 Place KING Flex in position.

Place the KING Flex on a stable surface. With its built-in leveling feature, the KING Flex does not need to be level, but make sure it is stable to prevent movement during operation.

NOTE: When placing the KING Flex on the ground, be sure ground is dry and free of loose dirt or sand. Do not place in an area where water may potentially pool or where water does not drain properly. The KING Flex may need to be above ground, such as on a platform, table, etc. Failure to follow these instructions may void the warranty.

IMPORTANT! Do not block the antenna's line of sight to satellites in the southern sky at any time.

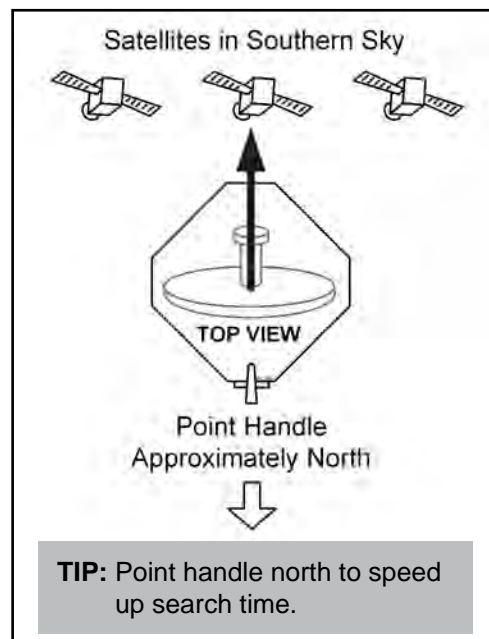

3 Make connections A-E in order shown on opposite page.

IMPORTANT! HAND TIGHTEN COAX CONNECTIONS. DO NOT USE A WRENCH.

Do not allow the coax cable to become bent or kinked.
Do not leave the coax cable where it can be tripped on or run over by a vehicle.

4 Go to Page 4.

KING Flex Antenna Unit
(located outside)

**AVOID SHARP BENDS
WHEN ROUTING COAX!**

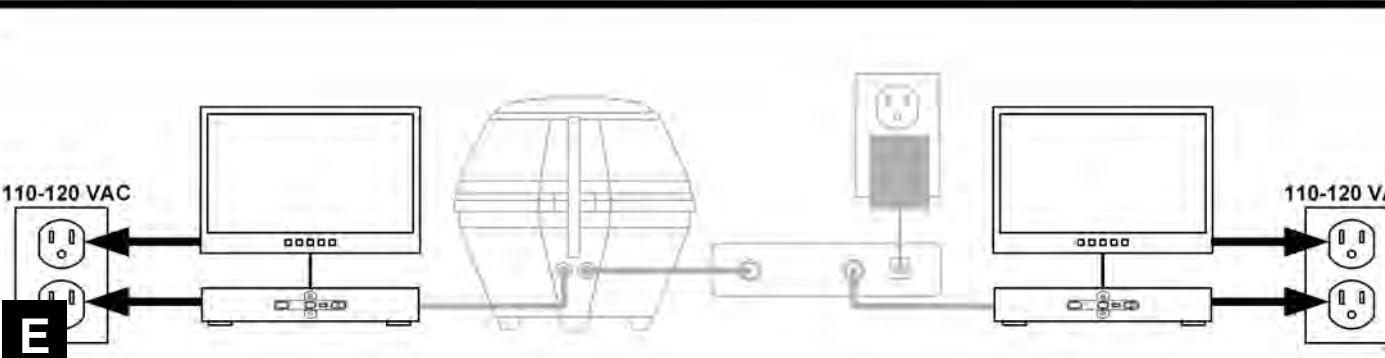
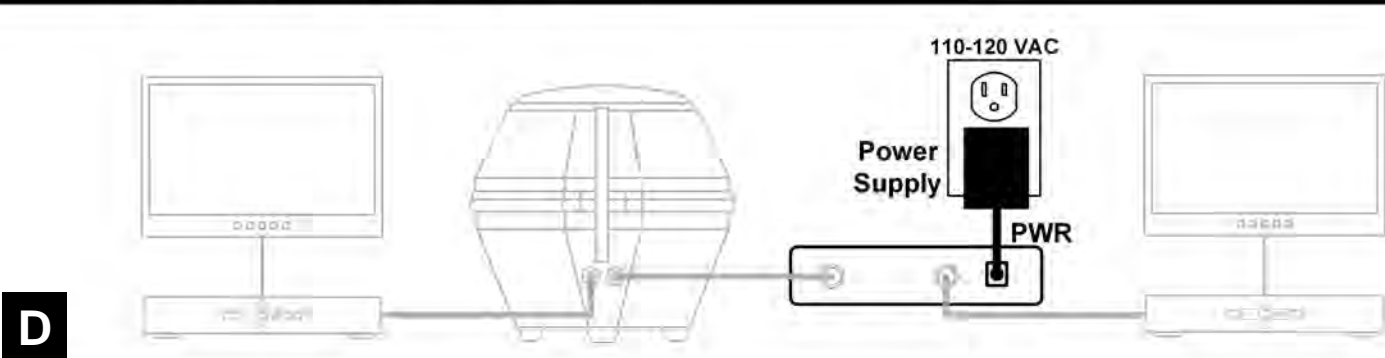
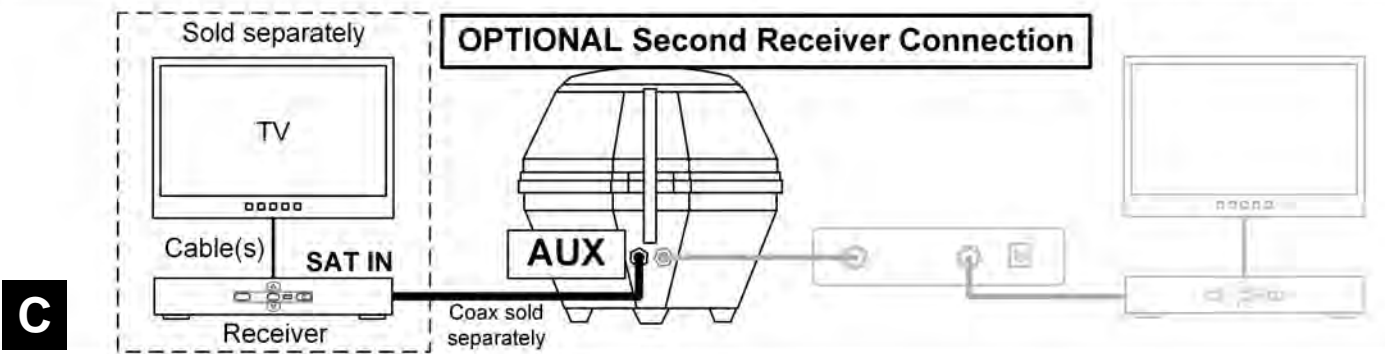
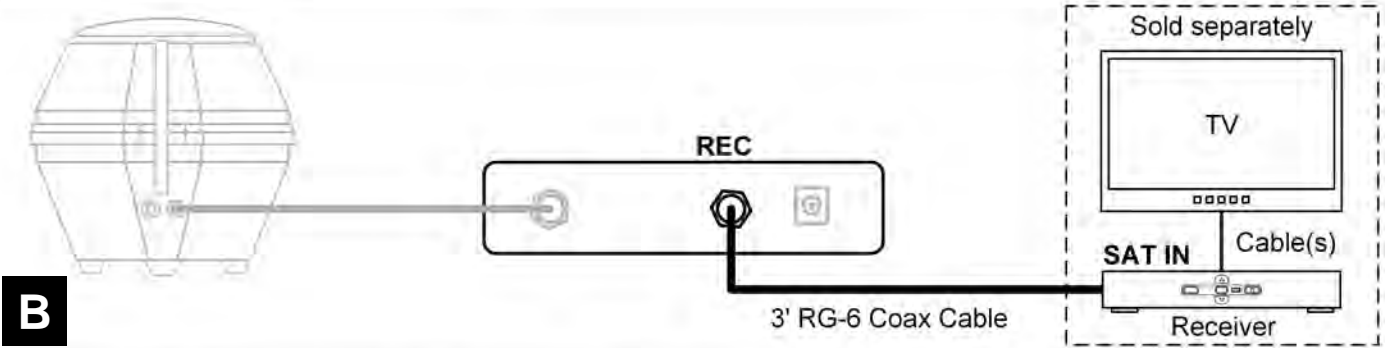
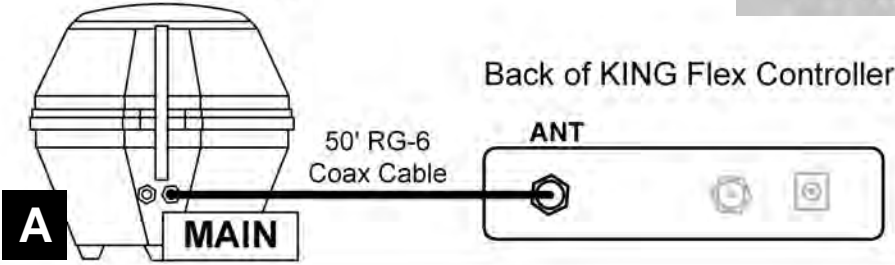

Section 2 ANTENNA AND ALARM CONFIGURATION

NOTE: If you have **DIRECTV SD** service you do not need to configure your antenna. Go to step 7 on next page.

If you wish to disable the alarm feature, complete all of the steps on these two pages.

ANTENNA CONFIGURATION

The KING Flex is factory pre-set for DIRECTV standard digital programming broadcast from the 101° W satellite (**DIRECTV SD**). If you also receive your local channels from DIRECTV's 119 satellite (**DIRECTV SD with Locals**), you must configure the antenna to work with your local channels.

Antenna configuration is a one time procedure that **MUST BE COMPLETED** before using your KING Flex antenna. To configure your antenna, do the following:

1. Press **POWER** to turn on KING Flex controller. The **COAX CONNECTION** light will flash 10 times and then turn on, and the **SCAN PROGRESS** lights will flash 3 times to indicate the selected service configuration.
2. Simultaneously press and hold **POWER** and **SCAN** for five seconds.

The **COAX CONNECTION** light and the **SCAN PROGRESS** lights that indicate the currently selected service will begin flashing.

3. Press **SCAN** repeatedly to scroll thru the available service provider options.

SATELLITE SERVICE CHART

Service	Satellites	Light 1	Light 2	Light 3	Light 4
DIRECTV SD	101	●	○	○	○
DIRECTV SD with Locals	101, 119	●	●	○	○
DISH SD	110, 119	●	○	●	○
DISH SD and HD	110, 119, 123	●	●	●	○
DISH SD and HD-Advanced	51, 5, 110, 119	●	○	●	●
BELL SD	81	○	●	○	○
BELL HD and HD	82, 81	○	●	●	○
TAILGATER MODE	110, 119, 123	○	●	●	●

○ = OFF ● = ON

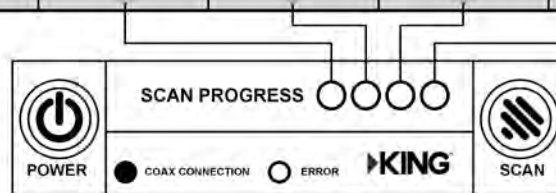

NOTE: To verify the current service configuration without changing it, perform steps 1-2 and 4-6.

4. When the correct lights turn on to show your desired satellite configuration, simultaneously press and hold **POWER** and **SCAN** for five seconds.

Your antenna configuration will be saved. All **SCAN PROGRESS** lights will turn off and the **COAX CONNECTION** light will continue to flash.

The unit will now enter Alarm Configuration mode.

ALARM CONFIGURATION

After entering Alarm Configuration Mode using the previous steps, audible beeping will confirm the alarm condition:

Single Beep (beep...beep...beep).....Alarm is **OFF**.

Double Beep (beep beep...beep beep)Alarm is **ON**.

5. Press and release **SCAN** to toggle between the on and off conditions. Beep pattern will change to indicate new condition.
6. When alarm is in desired condition, press **POWER** and **SCAN** for 5 seconds to exit Alarm Mode. Alarm condition will be saved. **COAX CONNECTION** light will turn solid and **SCAN PROGRESS** lights will stay off.

Notes on Alarm Feature

When alarm is enabled: If the coax cable is disconnected from the antenna unit or the controller while the system is turned on or in standby mode, the controller will sound an audible alarm.

To turn off the alarm when it is sounding, press **POWER** until the controller turns off.

This unit is shipped from the factory with the alarm feature in the ON condition.

If you wish to change the alarm from its previous state, perform steps 1-2 and 4-6 on these two pages.

7. Set your receiver options as follows:

IMPORTANT! The KING Flex will not work with SWM only receivers.

DIRECTV SD

If you have a newer receiver or current software, choose the following dish configuration settings (do this through the receiver's satellite set-up menu screens):

Switch Type: 02:Multiswitch • Dish Type: 01: 18" Round
(older receivers: choose round dish-1 satellite)

DIRECTV SD with Locals

If you have a newer receiver or current software, choose the following dish configuration settings (do this through the receiver's satellite set-up menu screens):

Switch Type: 02:Multiswitch • Dish Type: 02: 3-LNB (18 x 20")
(older receivers: choose oval dish-2 satellites)

8. Go to page 6.

Section 3 OPERATION

IMPORTANT! The KING Flex will not receive channels broadcast from DIRECTV's Ka band satellites at 99° and 103°.

The KING Flex will not work with SWM only receivers.

NOTE: Your local channels may not be available when traveling outside your home area.

IMPORTANT!

The antenna unit requires a "direct line of sight" to the satellites for signal reception.

Any tall objects can block the signal from reaching the antenna.

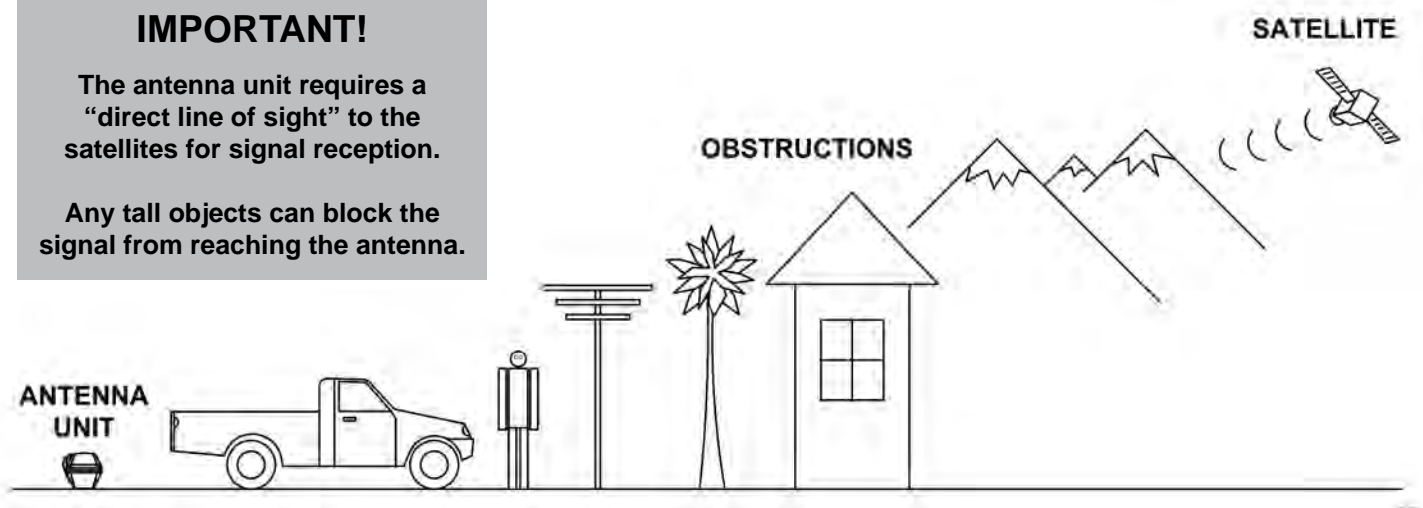

POWER UP

1. Make sure all connections are made as shown on page 3.

2. Press **POWER** to turn on KING Flex controller.

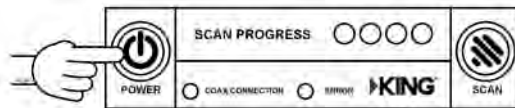

- All lights turn on briefly.
- The **COAX CONNECTION** light flashes 10 times.
- The **SCAN PROGRESS** lights flash 3 times to indicate the currently selected service configuration and then turn off.
- If the unit is operating properly, the **COAX CONNECTION** light will remain on and all other lights will turn off.

3. Turn the TV and satellite receiver on.

- Antenna is now ready to scan for satellites. Go to next page.

SCAN FOR SATELLITES

4. Press and hold **SCAN** for 3 seconds.

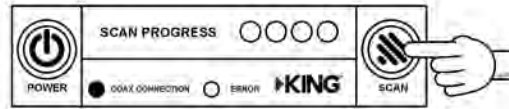

- The antenna will scan for the selected satellites. The four **SCAN PROGRESS** lights will cycle on and off to indicate a scan is in progress.
- As satellites are located, the corresponding **SCAN PROGRESS** lights will turn on (see below).
- When scan is complete, the appropriate lights will turn on to show which satellites were found.
- Wait for the program guide to download and then select your desired channel.

“SATELLITES FOUND” CHART

Service	Satellites	Light 1	Light 2	Light 3	Light 4
DIRECTV SD	101	●	○	○	○
DIRECTV SD with Locals	101, 119	●	●	○	○

NOTE: Light 1 = Satellite 101, Light 2 = Satellite 119

NOTE: If you move the antenna unit, you will have to re-acquire the satellites by repeating the scan process. The KING Flex will go into “sleep mode” after 15 minutes and the **COAX CONNECTION** light will dim. Press **POWER** to wake up unit if necessary, i. e. the unit is in sleep mode, you move the unit, and wish to rescan for satellites.

To turn the unit off at any time, press **POWER** for 3 seconds.

DISH

THANK YOU for your purchase of the **KING Flex Portable Automatic Satellite TV Antenna!**

The KING Flex portable satellite antenna is easily configured to lock onto the appropriate satellites necessary to receive your favorite SD and HD programming from DISH.

DISH subscribers, please use the information in this section to operate your system. You will also find helpful information on troubleshooting, security, the warranty, and KING Flex mounting brackets in the Appendix at the end of this manual.

IMPORTANT! DISH CUSTOMERS WITH HD SOLO RECEIVERS ONLY!

If you have a DISH model ViP211z, ViP211k, ViP211 or 411 single tuner HD receiver, you can use the simplified DISH Tailgater® user interface on your receiver.

DO SECTIONS 1, 2 AND 6. SKIP SECTIONS 3, 4 and 5.

Section 1

SETUP

Pages 2-3

Section 2

ANTENNA AND ALARM CONFIGURATION

Pages 4-5

Section 3

RECEIVER CONFIGURATION

Pages 6-8

Section 4

OPERATION

Pages 10-11

Section 5

2ND RECEIVER OPERATION

Pages 12-13

Section 6

TAILGATER MODE

Pages 14-23

1

DISH

1 Make sure you have everything you need.

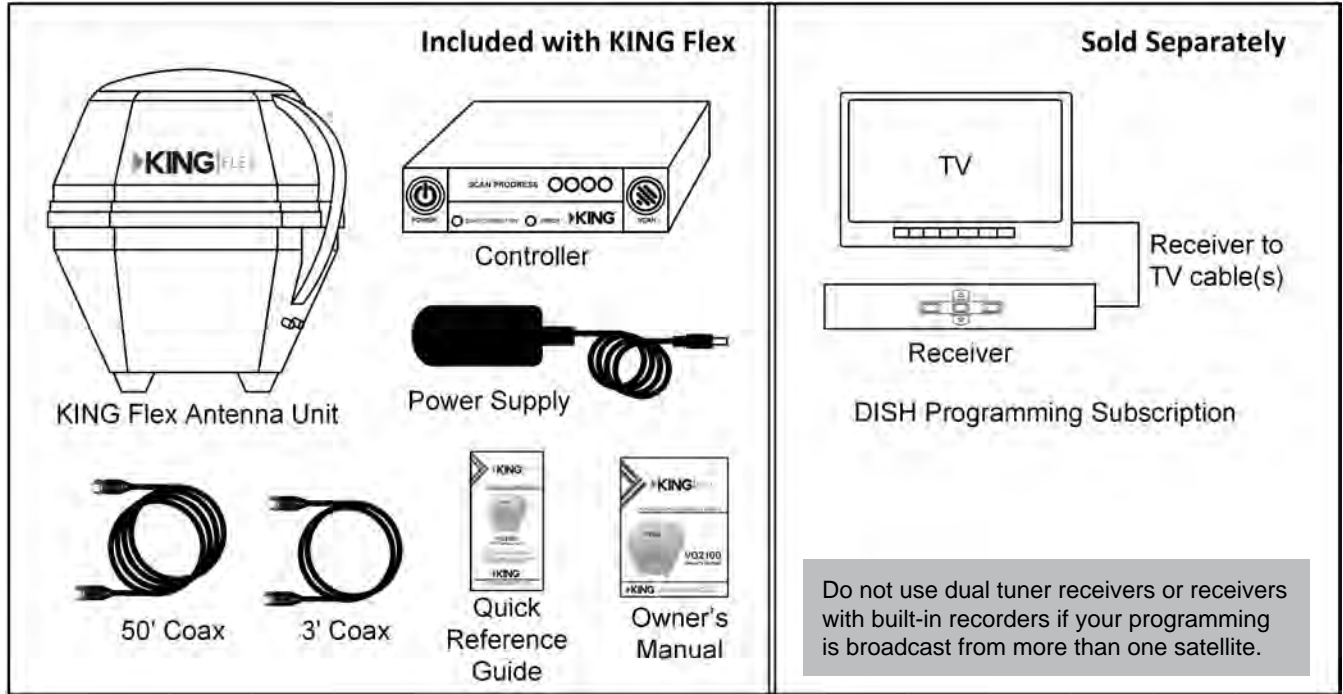

2 Place KING Flex in position.

Place the KING Flex on a stable surface. With its built-in leveling feature, the KING Flex does not need to be level, but make sure it is stable to prevent movement during operation.

NOTE: When placing the KING Flex on the ground, be sure ground is dry and free of loose dirt or sand. Do not place in an area where water may potentially pool or where water does not drain properly. The KING Flex may need to be above ground, such as on a platform, table, etc. Failure to follow these instructions may void the warranty.

IMPORTANT! Do not block the antenna's line of sight to satellites in the southern sky at any time.

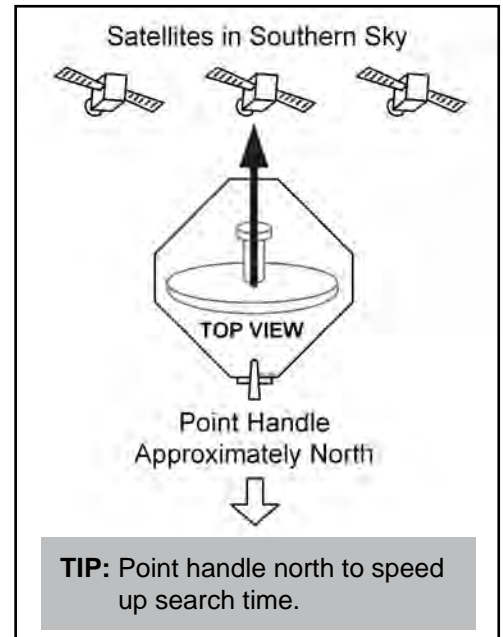

3 Make connections A-D in order shown on opposite page.

IMPORTANT! HAND TIGHTEN COAX CONNECTIONS. DO NOT USE A WRENCH.

Do not allow the coax cable to become bent or kinked.
Do not leave the coax cable where it can be tripped on or run over by a vehicle.

4 Go to Page 4.

KING Flex Antenna Unit
(located outside)

**AVOID SHARP BENDS
WHEN ROUTING COAX!**

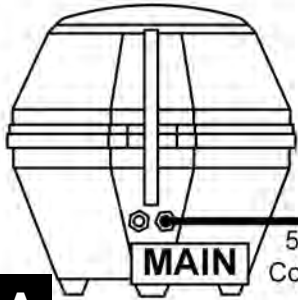

Back of KING Flex Controller

ANT

50' RG-6
Coax Cable

A



REC

3' RG-6 Coax Cable

Sold separately

TV

Cable(s)

SAT IN

Receiver

B

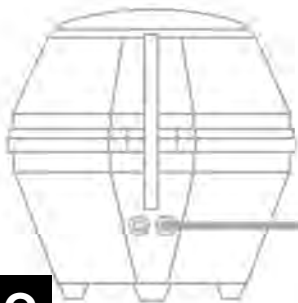

110-120 VAC

Power
Supply

PWR

C

If using a second receiver, it will be connected in
Section 5 on page 12.

(2nd receiver not recommended for Tailgater Mode.)

D

110-120 VAC

ANTENNA CONFIGURATION

You must configure the antenna to work with your DISH satellite service. Doing this will allow the KING Flex to lock on the correct satellites to receive your programming and also enable automatic satellite switching via the receiver's remote control for multi-satellite service.

Antenna configuration is a one time procedure that **MUST BE COMPLETED** before using your KING Flex antenna. To configure your antenna, do the following:

1. Press **POWER** to turn on KING Flex controller. The **COAX CONNECTION** light will flash 10 times and then turn on, and the **SCAN PROGRESS** lights will flash 3 times to indicate the selected service configuration.
2. Simultaneously press and hold **POWER** and **SCAN** for five seconds.

The **COAX CONNECTION** light and the **SCAN PROGRESS** lights that indicate the currently selected service will begin flashing.

3. Press **SCAN** repeatedly to scroll thru the available service provider options.

SATELLITE SERVICE CHART

Service	Satellites	Light 1	Light 2	Light 3	Light 4
DIRECTV SD	119	●	○	○	○
DIRECTV SD and HD	110, 119	●	●	○	○
DISH SD	110, 119	●	○	●	○
DISH SD and HD	110, 119, 129	●	●	●	○
DISH SD and HD Alternate	61.5, 110, 119	●	○	●	●
BELL SD	129	○	○	○	○
BELL SD and HD	129	○	○	○	○
TAILGATER MODE (See below)	110, 119, 129	○	●	●	●

○ = OFF ● = ON

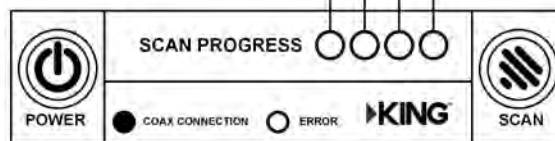

NOTE: If you have a DISH receiver **ViP211z, ViP211k, ViP211** or **411**, ***FIRST*** choose the **TAILGATER MODE** setting as instructed on these two pages, and then continue with Tailgater Mode (Section 6, page 14).

To verify the current service configuration without changing it, perform steps 1-2 and 4-6.

4. When the correct lights turn on to show your desired satellite configuration, simultaneously press and hold **POWER** and **SCAN** for five seconds.

Your antenna configuration will be saved. All **SCAN PROGRESS** lights will turn off and the **COAX CONNECTION** light will continue to flash.

The unit will now enter Alarm Configuration mode.

ALARM CONFIGURATION

After entering Alarm Configuration Mode using the previous steps, audible beeping will confirm the alarm condition:

Single Beep (beep...beep...beep).....Alarm is **OFF**.

Double Beep (beep beep...beep beep)Alarm is **ON**.

5. Press and release **SCAN** to toggle between the on and off conditions. Beep pattern will change to indicate new condition.
6. When alarm is in desired condition, press **POWER** and **SCAN** for 5 seconds to exit Alarm Mode. Alarm condition will be saved. **COAX CONNECTION** light will turn solid and **SCAN PROGRESS** lights will stay off.

Notes on Alarm Feature

When alarm is enabled: If the coax cable is disconnected from the antenna unit or the controller while the system is turned on or in standby mode, the controller will sound an audible alarm.

To turn off the alarm when it is sounding, press **POWER** until the controller turns off.

This unit is shipped from the factory with the alarm feature in the ON condition.

If you wish to change the alarm from its previous state, perform steps 1-2 and 4-6 on these two pages.

IF YOU CHOSE TAILGATER MODE, GO TO PAGE 14.

IF NOT, GO TO RECEIVER CONFIGURATION ON NEXT PAGE.

Section 3 RECEIVER CONFIGURATION

IMPORTANT! YOU MUST HAVE COMPLETED THE ANTENNA CONFIGURATION ON PAGES 4-5 BEFORE CONTINUING BELOW.

NOTE: For automatic satellite switching, KING recommends using a DISH model 311 receiver for **DISH SD**. For **DISH SD and HD**, you can use receiver models ViP211z, ViP211k, ViP211, and 411, but we highly recommend using Tailgater mode with these receivers for simplified operation with the receiver's built in Tailgater interface.

If you do not have a clear view of the satellites, the switch will not load correctly.

The SW21 and SW64 switches are a receiver software configuration that is loaded into the receiver after successfully running a check switch test with the dish locked on and configured for the appropriate service.

This one time procedure will not need to be repeated after successful installation, unless:

- check switch test is run again while the receiver is connected to a home dish system.
- check switch test is run when the receiver is not connected.
- you travel outside the coverage area of either **DISH SD and HD** or **DISH SD and HD Alternate** and switch to the other.
- you are parked in an area where the selected satellites are blocked, but are able to select alternate satellites and get signal.

IMPORTANT!

The antenna unit requires a "direct line of sight" to the satellites for signal reception.

Any tall objects can block the signal from reaching the antenna.

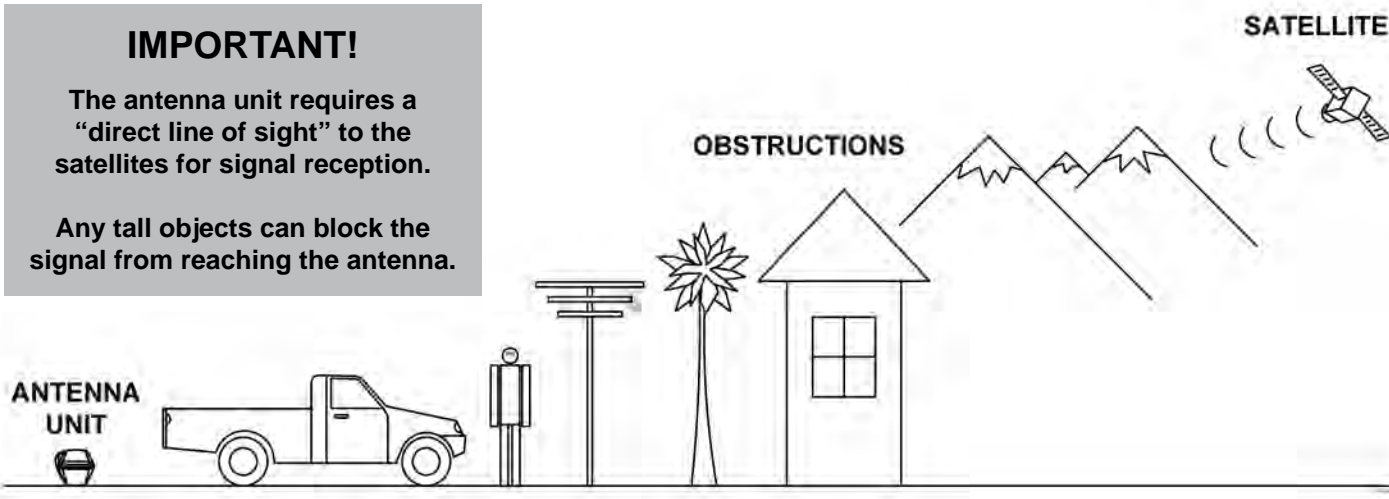

- Turn on the TV and satellite receiver.
- Your KING Flex controller should be on from the configuration process on pages 4-5. If not, press **POWER** and wait for the **COAX CONNECTION** light to remain on.

Press and hold **SCAN** for 3 seconds.

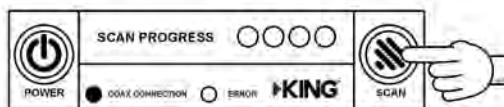

The antenna will locate all of the appropriate satellites before completing the search process.

After the antenna acquisition process is complete, specific SCAN PROGRESS lights will turn on to indicate which satellites have been found (see chart on page 11).

If you configured the antenna for DISH SD and HD and the antenna cannot acquire the 110, 119, and 129 satellites, you may need to configure the antenna for DISH SD and HD Alternate (pages 4-5).

3. On the receiver remote, press **MENU, 6, 1, 1**.

4. Highlight "Check Switch."

Press **SELECT** on your remote.

NOTE: Some receivers may prompt you to select "Check Switch" a second time to initiate the test.

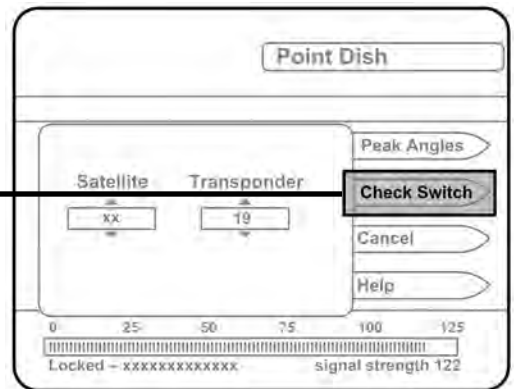

Screen graphics may vary.

5. Make sure "SuperDISH" and "Alternate" boxes are **NOT** selected.

NOTE: Not all receivers will display a screen with options that include "SuperDISH" and "Alternate" boxes.

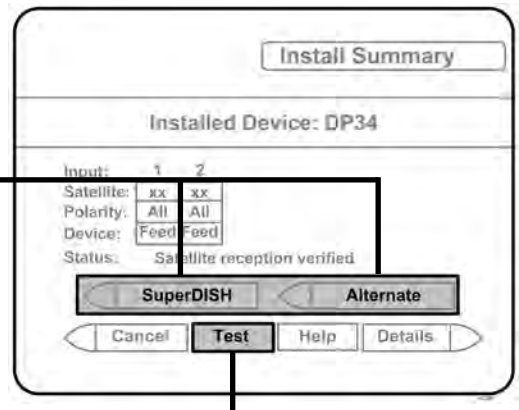

6. Highlight "Test."

Press **SELECT** on your remote.

The receiver will perform a check switch test. This process can take a little while so PLEASE BE PATIENT.

7. When test is complete, a screen similar to one **below or on the next page** should appear. After screen verification, continue with check switch test procedure on next page.

Because receivers are always changing, screen graphics may vary.

DISH SD

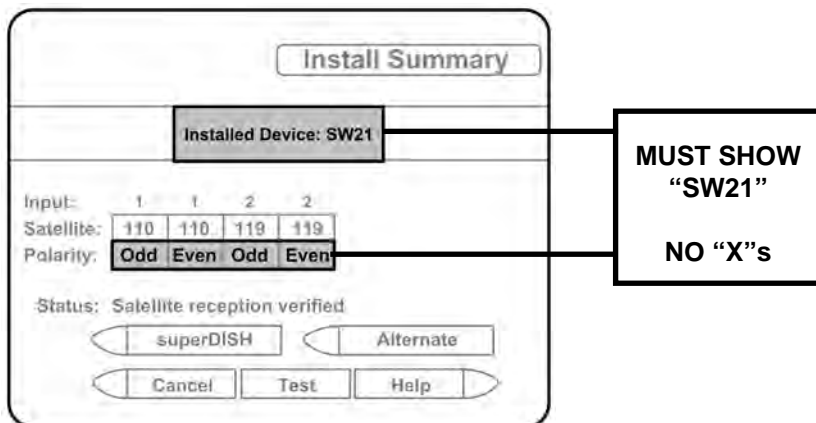

DISH SD and HD

DISH SD and HD Alternate

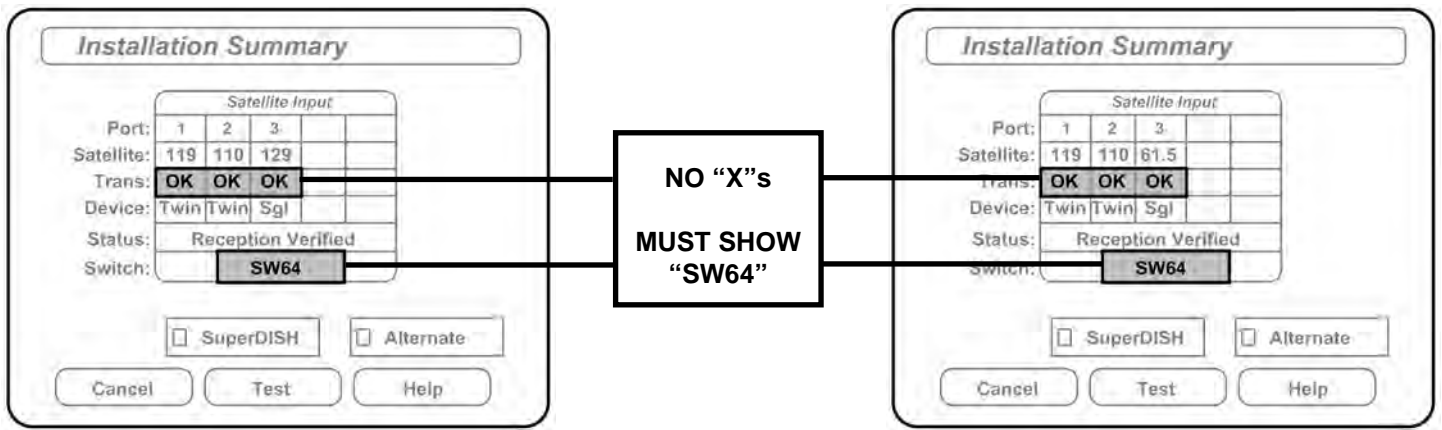

If the indicated results are not obtained, go back to Step 3 and run test again. Contact KING if the check switch fails to load after 4 attempts.

- When the installation summary shows the successful check switch test results, save the settings, exit to the main menu screen and wait for programming to download.
- DISH SD and HD** and **DISH SD and HD Alternate** only: Verify that your saved settings show your desired satellite trio: 61.5, 110, 119 or 110, 119, 129. To switch trios, see pages 4-5.

Configuration is complete. Go to page 10, OPERATION.

IMPORTANT! If you chose Tailgater Mode do not use these operating instructions. Go to page 14.

Your local channels may not be available when traveling outside your home area.

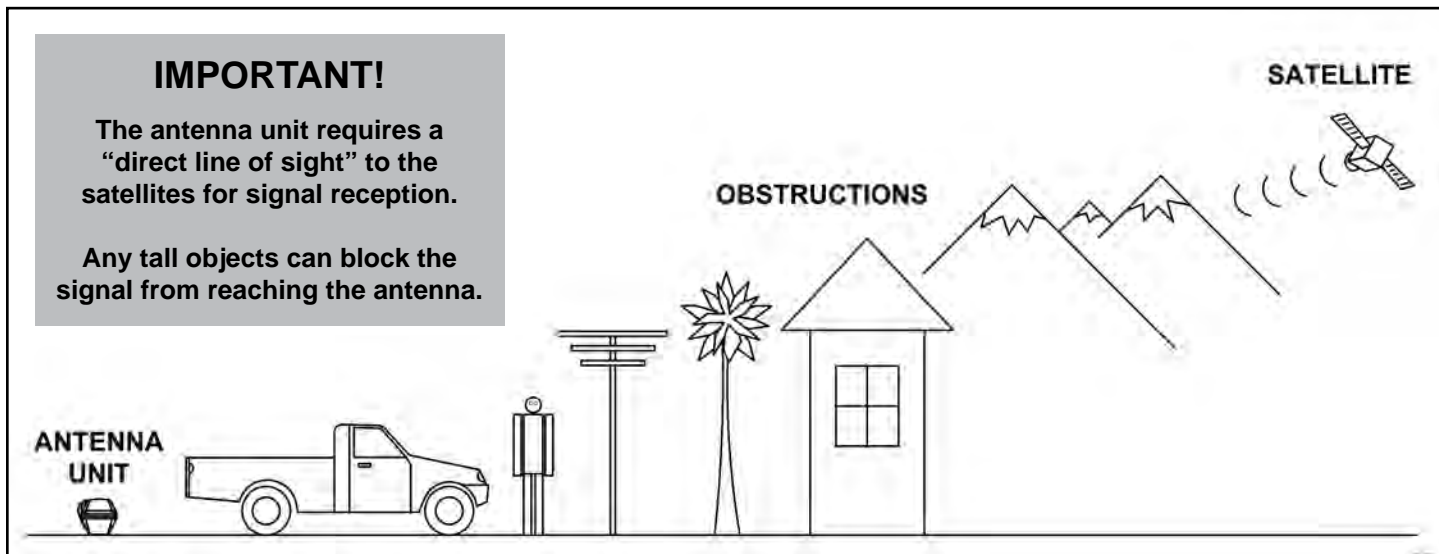

POWER UP

1. Make sure all connections are made as shown on page 3.

2. Press **POWER** to turn on KING Flex controller.

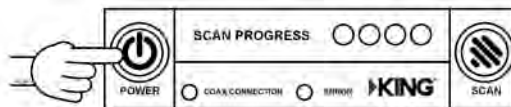

- All lights turn on briefly.
- The **COAX CONNECTION** light flashes 10 times.
- The **SCAN PROGRESS** lights flash 3 times to indicate the currently selected service configuration and then turn off.
- If the unit is operating properly, the **COAX CONNECTION** light will remain on and all other lights will turn off.

3. Turn the TV and satellite receiver on.

- Antenna is now ready to scan for satellites. Go to next page.

SCAN FOR SATELLITES

4. Press and hold **SCAN** for 3 seconds.

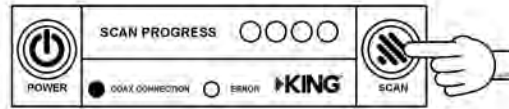

- The antenna will scan for the selected satellites. The four **SCAN PROGRESS** lights will cycle on and off to indicate a scan is in progress.
- As satellites are located, the corresponding **SCAN PROGRESS** lights will turn on (see below).
- When scan is complete, the appropriate lights will turn on to show which satellites were found.
- Wait for the program guide to download and then select your desired channel.

“SATELLITES FOUND” CHART

Service	Satellites	Light 1	Light 2	Light 3	Light 4
DISH SD	110, 119	●	●	○	○
DISH SD and HD	110, 119, 129	●	●	●	○
DISH SD and HD Alternate	61.5, 110, 119	●	●	●	○

○ = OFF ● = ON

NOTE: The order of the lights corresponds to the order of the satellites listed.
EXAMPLE: DISH SD: Light 1 = Satellite 110, Light 2 = Satellite 119

NOTE: If you move the antenna unit, you will have to re-acquire the satellites by repeating the scan process. The KING Flex will go into “sleep mode” after 15 minutes and the **COAX CONNECTION** light will dim. Press **POWER** to wake up unit if necessary, i. e. the unit is in sleep mode, you move the unit, and wish to rescan for satellites.

To turn the unit off at any time, press **POWER** for 3 seconds.

If you are using a second receiver, see **SECOND RECEIVER OPERATION** on page 12.

INITIAL SETUP FOR SECOND RECEIVER

1. With the second receiver disconnected from the antenna unit's AUX port coax, use your DISH remote control and press **MENU, 6, 1, 1** to display the *Point Dish* screen.

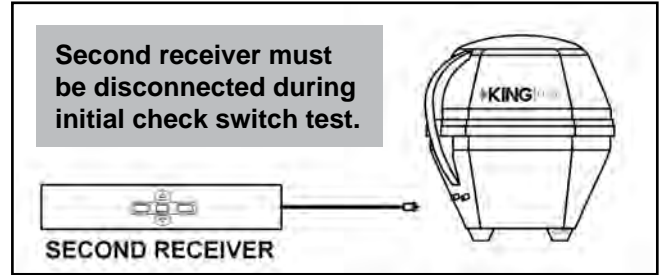

2. Use the arrow buttons on the remote to highlight "Check Switch." Press **SELECT** on your remote.

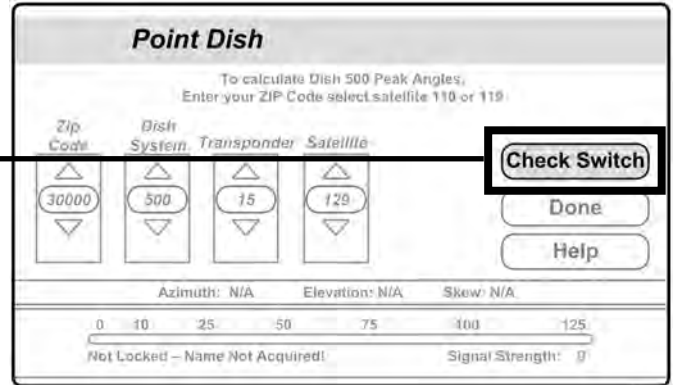

3. Verify "SuperDISH" and "Alternate" are not selected. Verify "Test" is highlighted.

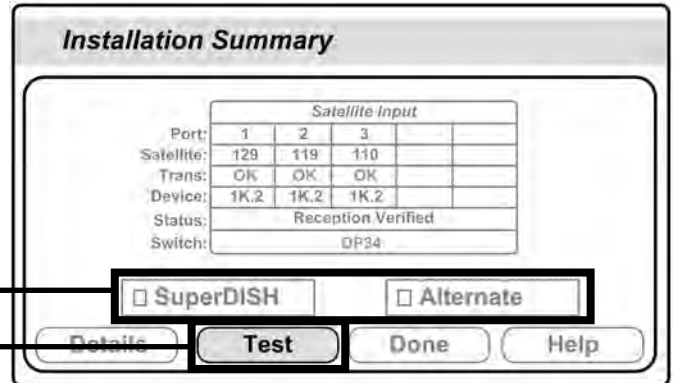

- Press **SELECT** on your remote.
- Wait for check switch test to finish.

4. Connect second receiver to antenna unit's MAIN port and run check switch again using steps above.

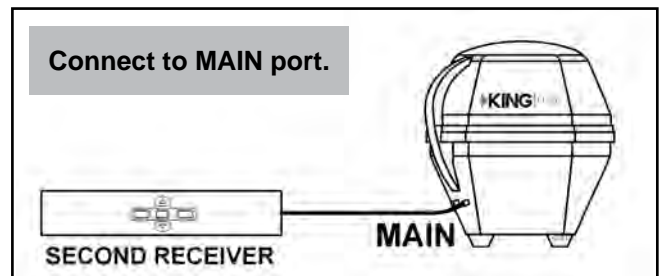

5. When test is complete, highlight "Save."

Press **SELECT** on your remote.

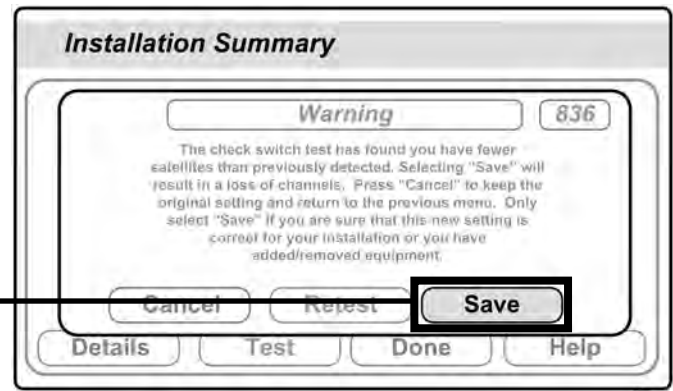

6. After successfully saving the results, connect the second receiver to the AUX port.

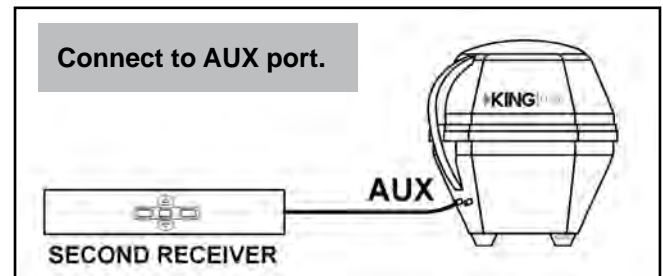

DOWNLOADING PROGRAMMING TO THE SECOND RECEIVER

1. With the second receiver now connected, and the antenna locked on (see OPERATION section), re-set the second receiver by pressing the POWER button on the front panel for 10 seconds. The TV picture will go away and should reappear within two minutes.

The receiver will then download the program guide to show only the channels available on the current satellite as determined by the channel selected on the main receiver. Downloading the new program guide can take up to five minutes to complete.

The channels available on the second receiver are determined by the channel/satellite selected on the main receiver. For example, if you select a channel on the main receiver that is broadcast from the 119 satellite, then the second receiver will be able to display any channel broadcast from the 119 satellite.

If you switch channels on the main receiver to one that is broadcast from a different satellite, (i.e. your channel was broadcast from satellite 119 but your new channel is broadcast from the 110 or 129), the antenna will automatically switch to the new satellite and programming will be lost on the second receiver until you either:

- Select a channel on the main receiver that is broadcast from the previous satellite (satellite 119 in this example).

(or)

- Reset the second receiver to download the program guide for the newly selected satellite (satellite 110 or 129 in this example).

TIP: Most DISH HD channels are broadcast from the 129 satellite location. Selecting an HD channel on the main receiver before re-setting the second receiver will provide independent viewing of most available HD channels on either receiver.

IMPORTANT! You must have chosen Tailgater Mode on pages 4-5.

Your local channels may not be available when traveling outside your home area.

Use these steps if your receiver is NEW AND UNACTIVATED.

If it is not new, go to page 20.

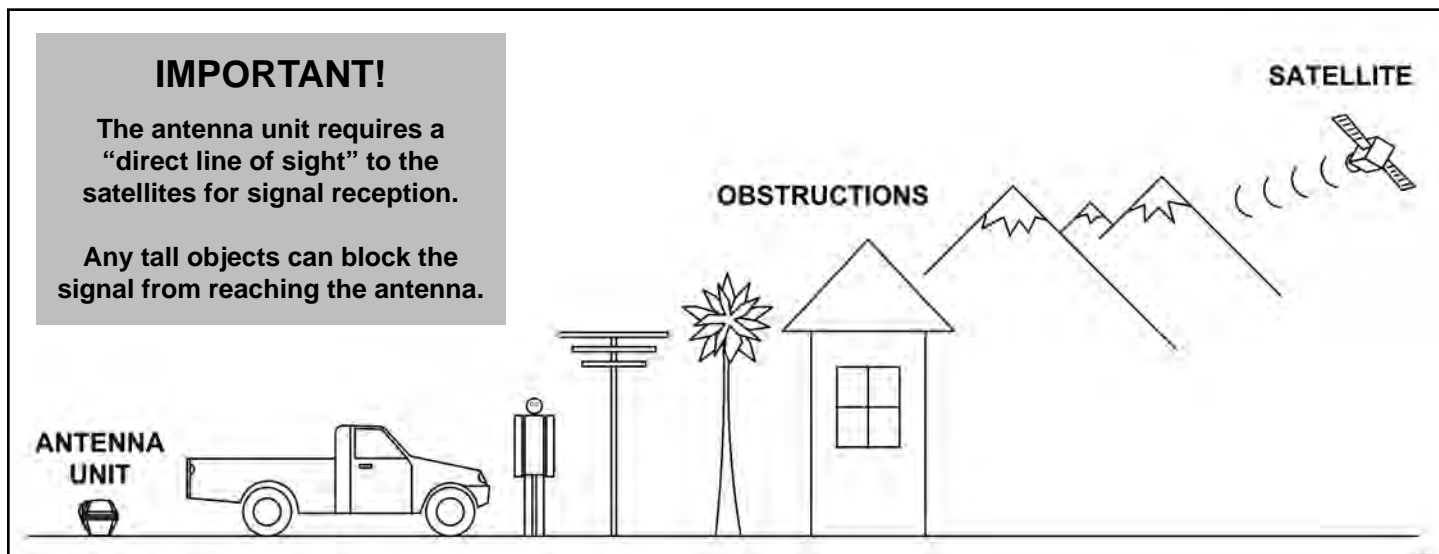

1. If your KING Flex controller is not on, press **POWER** and wait for the **COAX CONNECTION** light to remain on.
2. Plug your receiver and TV into a 110 volt AC power source.

The green power light on your receiver should illuminate or begin cycling on and off.

Wait for the green light to turn solid. This may take up to two minutes.

If it does not turn solid, power on your receiver using the front panel **POWER** button. (On “z” models, this is located behind the door panel.)

3. Plug in and turn on your TV.

In your TV’s input selection menu, choose the input that matches the connection from your receiver (example: if using an HDMI cable from your receiver, choose the HDMI input on your TV). See your TV owner’s manual for details.

- Point your receiver's remote at the front of the receiver and press **SAT**.

Press **RECORD**.

When a number appears in the box, verify "CONTINUE" is highlighted.

Press **SELECT** on your remote.

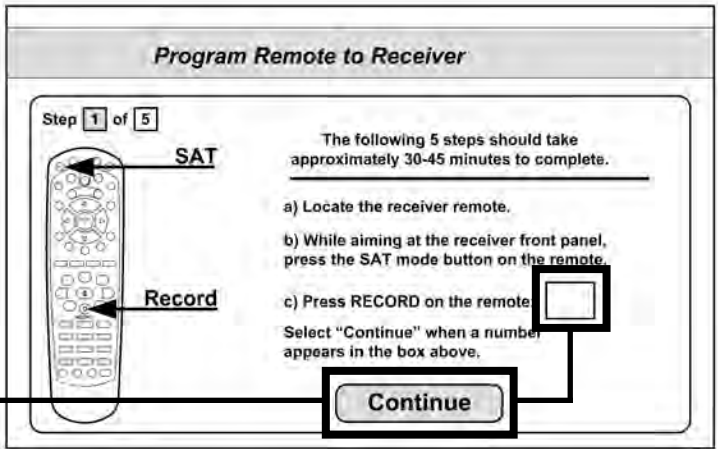

The *Portable Antenna Setup* screen will display.

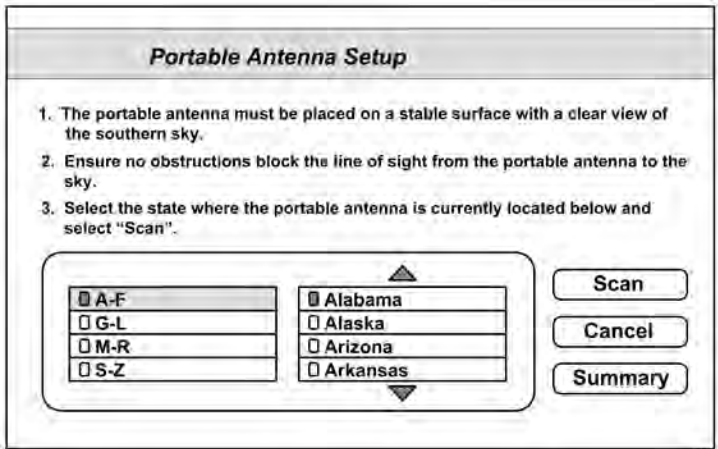

- Use the arrow buttons on your remote to highlight the letter group that includes the first letter of the state you are currently in.

Press **SELECT**.

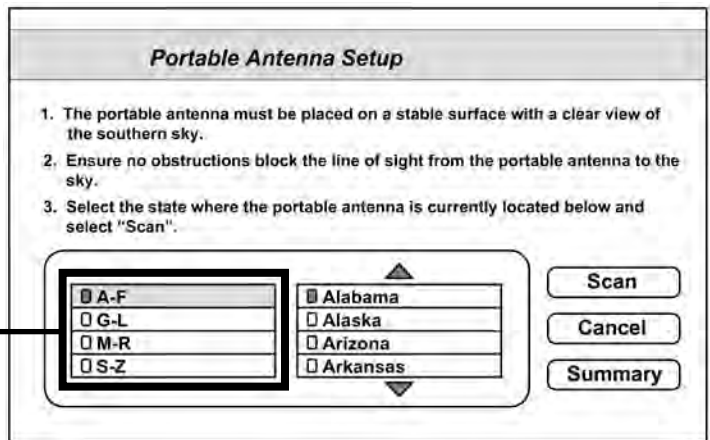

6. Highlight the state you are currently in from the state menu.

Press **SELECT**.

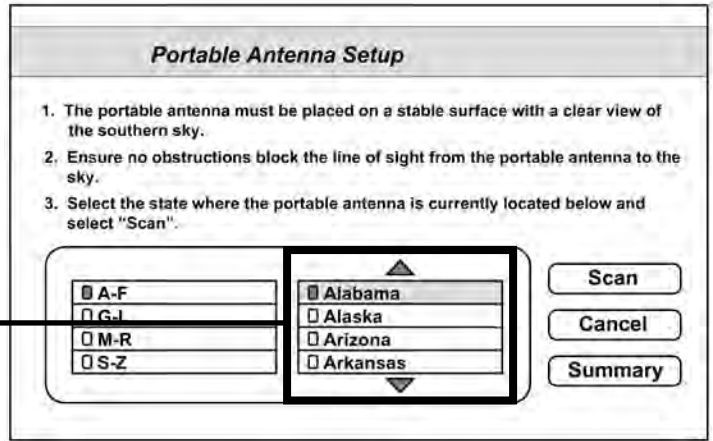

7. Verify "Scan" is highlighted.

Press **SELECT**.

The scan will begin and may take up to several minutes to complete.

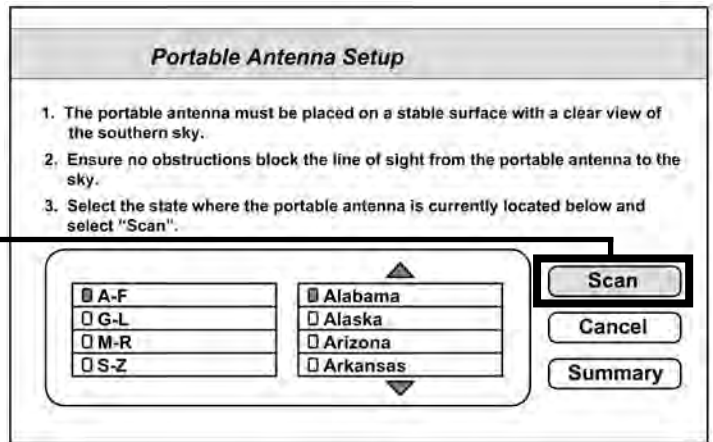

The receiver will update software for DISH programming. This step may take 20-25 minutes.

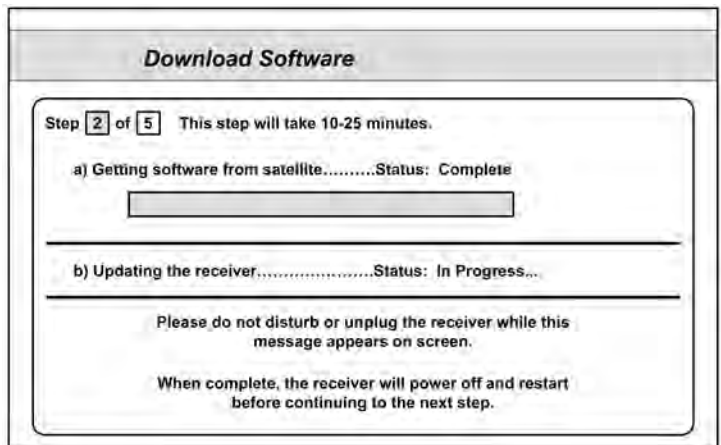
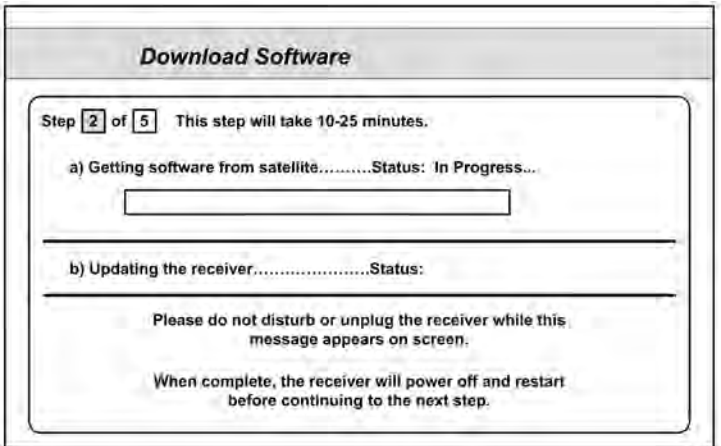

8. The receiver will reset and the *Mobile Antenna Setup* Screen will appear. Choose your location again and initiate a second scan.

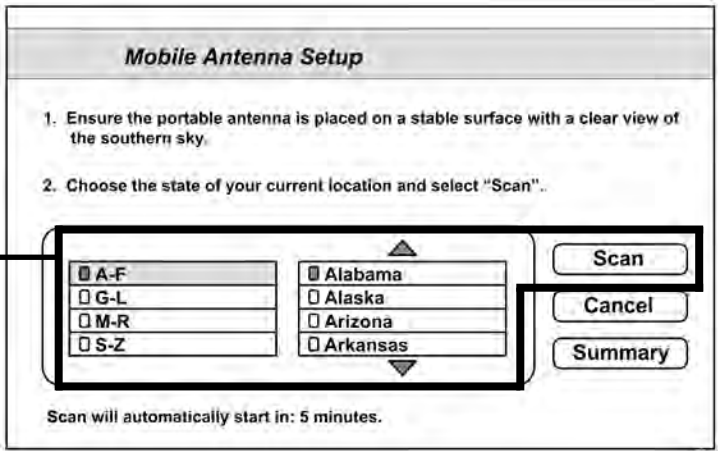

The unit will scan a second time.

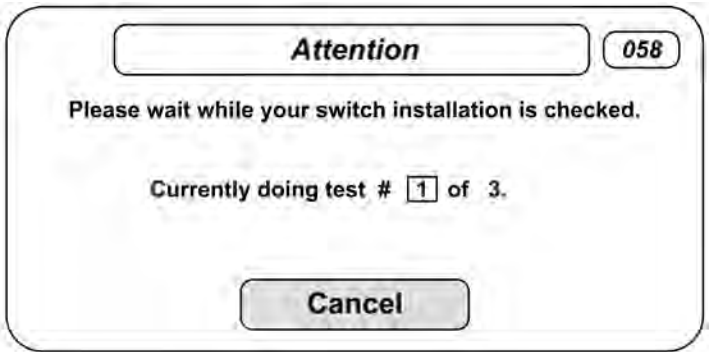

When the scan is complete, the "Acquiring Signal" message will display. Acquiring the signal may take up to 5 minutes to complete.

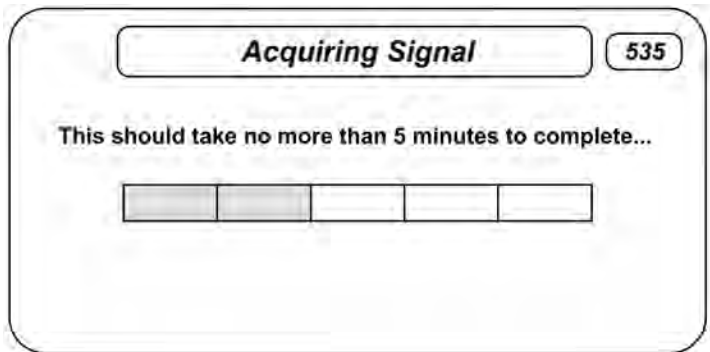

9. After your receiver has acquired the signal, it is ready to be activated. If your receiver packaging has a specific phone number displayed, be sure to call this number to activate your service. Otherwise, call 1-800-333-DISH (3474) to activate.



After your receiver is activated, the electronic program guide will download. This may take up to 5 minutes to complete (potentially longer if an external hard drive is connected).

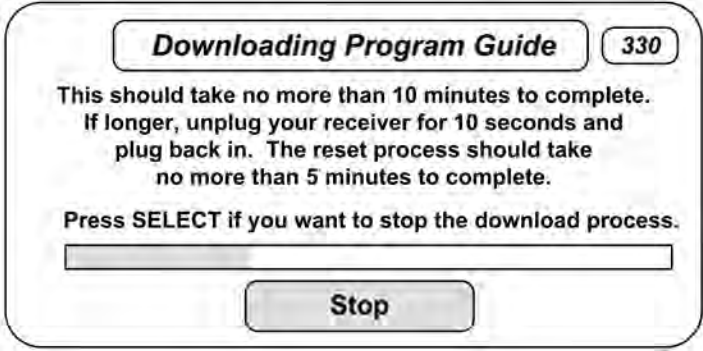

This completes the setup for new receivers.

From now on, use the standard operation procedure starting on page 20.

STANDARD TAILGATER OPERATION

IMPORTANT! You must have chosen Tailgater Mode on pages 4-5.

Your local channels may not be available when traveling outside your home area.

If your receiver is **NEW AND UNACTIVATED**, start on page 14.

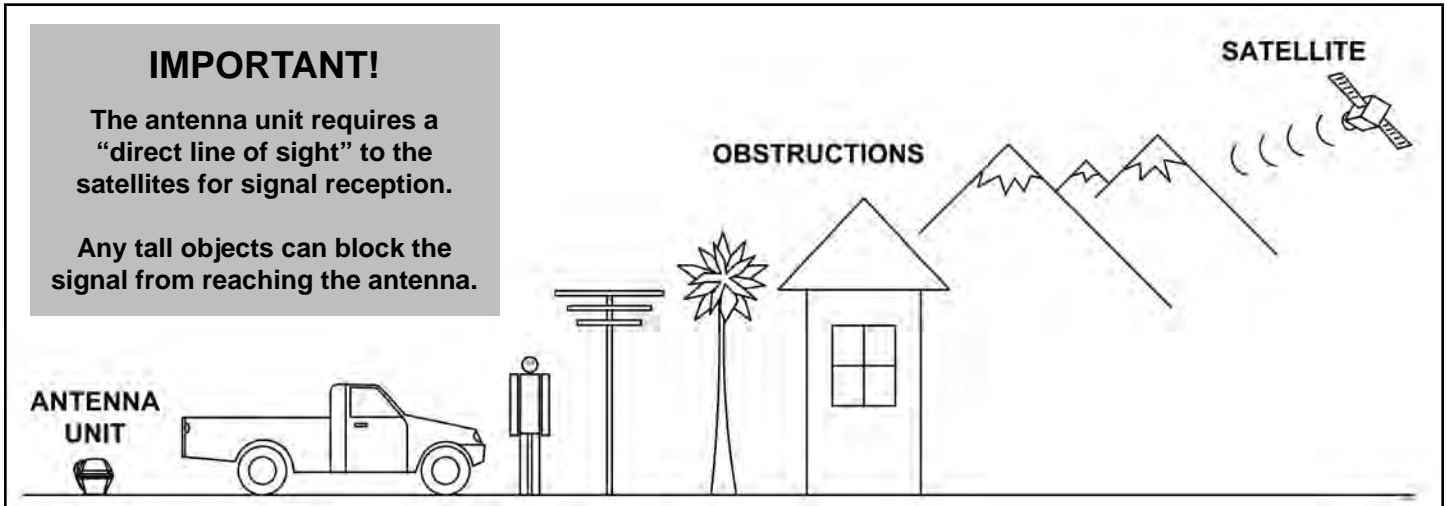

1. If your KING Flex controller is not on, press **POWER** and wait for the **COAX CONNECTION** light to remain on.
2. Plug your receiver and TV into a 110 volt AC power source.

The green power light on your receiver should illuminate or begin cycling on and off.

Wait for the green light to turn solid. This may take up to two minutes.

If it does not turn solid, power on your receiver using the front panel **POWER** button. (On “z” models, this is located behind the door panel.)

3. Plug in and turn on your TV.

In your TV’s input selection menu, choose the input that matches the connection from your receiver (example: if using an HDMI cable from your receiver, choose the HDMI input on your TV). See your TV owner’s manual for details.

The *Mobile Antenna Setup* screen will be displayed on your TV.

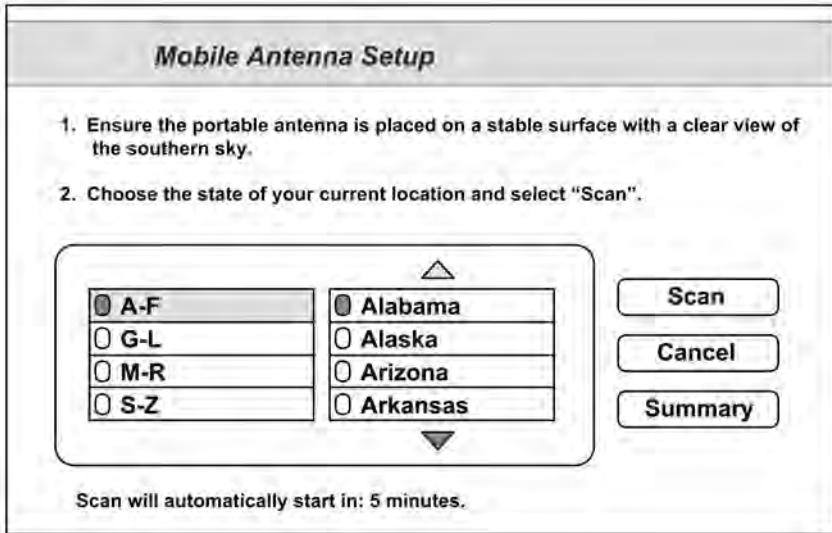

NOTE: If the *Mobile Antenna Setup* screen does not display, press **MENU, 6, 1, 1** on your DISH remote.

Highlight "Check Switch."

Press **SELECT** on your remote.

The *Mobile Antenna Setup* screen should now display.

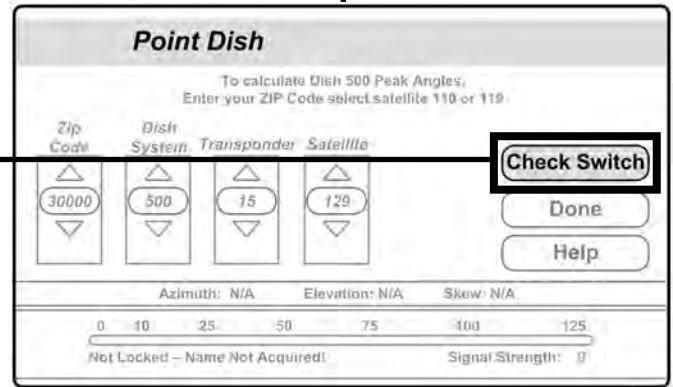

4. Use the arrow buttons on your remote to highlight the letter group that includes the first letter of the state you are currently in.

Press **SELECT** on your remote.

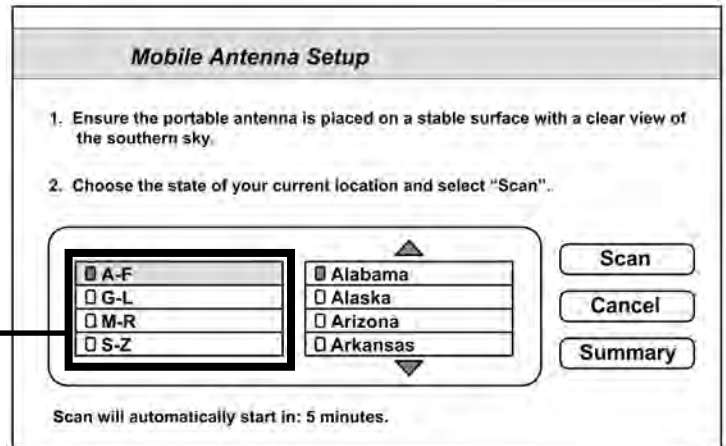

5. Highlight the state you are currently in from the state menu.

Press **SELECT**.

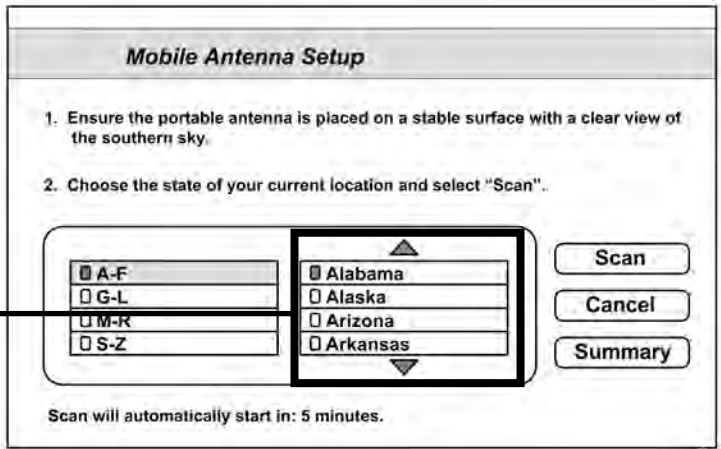

6. Verify "Scan" is highlighted.

Press **SELECT**.

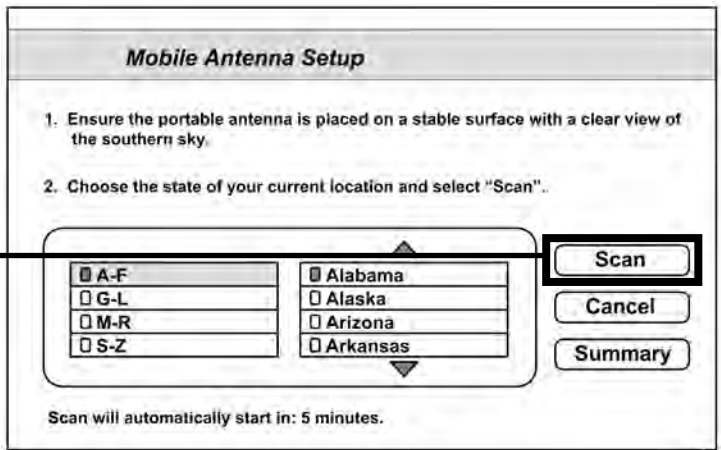

The scan will begin and may take up to several minutes to complete.

This screen will display during the scan.

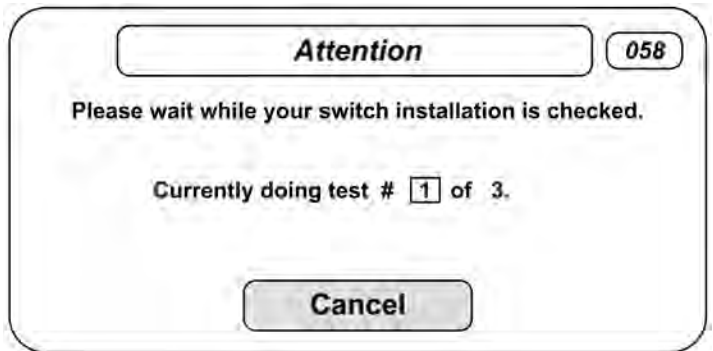

7. When the scan is complete, the "Acquiring Signal" message will display. Acquiring the signal may take up to 5 minutes to complete.

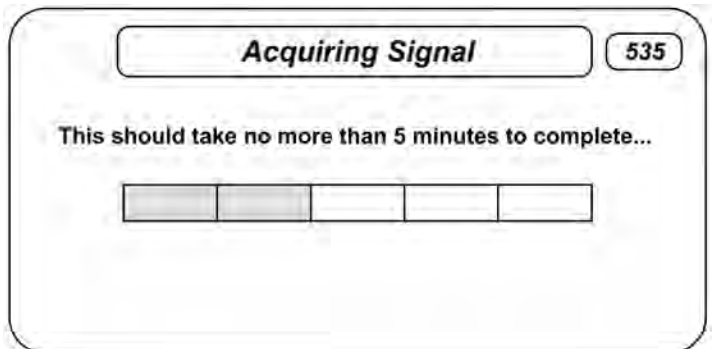

8. After your receiver has acquired the signal, the electronic program guide will download. This may take up to 5 minutes to complete (potentially longer if an external hard drive is connected).

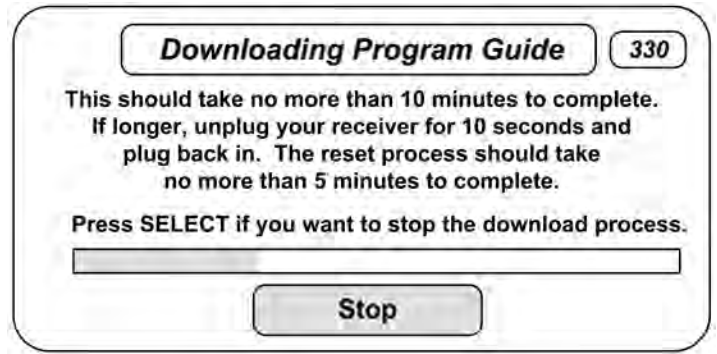

OPERATING NOTES

To turn the unit off at any time press **POWER** for 3 seconds.

If your system is inactive for an extended period of time, you may need to call DISH Customer Service at 1-800-333-DISH (3474) to re-authorize your receiver. You can view your programming when your receiver has been re-authorized and the guide has finished downloading.

If you move the antenna unit, you will need to repeat the scan process to re-acquire the satellites and restore programming.

When in the northeastern United States, television programming from the 129 satellite may not be available, so you may wish to configure your antenna for **DISH SD and HD Alternate**. Make sure the controller is turned off, and then use the procedure found in the ANTENNA CONFIGURATION section (pages 4-5). When you leave the northeastern US you will need to configure the antenna for Tailgater Mode once again.

Bell TV

THANK YOU for your purchase of the **KING Flex Portable Automatic Satellite TV Antenna!**

The KING Flex portable satellite antenna is easily configured to lock onto the appropriate satellites necessary to receive your favorite SD and HD programming from Bell TV.

Bell TV subscribers, please use the information in this section to operate your system. You will also find helpful information on troubleshooting, security, the warranty, and KING Flex mounting brackets in the Appendix at the end of this manual.

Section 1

SETUP

Pages 2-3

Section 2

ANTENNA AND ALARM CONFIGURATION

Pages 4-5

Section 3

RECEIVER CONFIGURATION

Pages 6-7

Section 4

OPERATION

Pages 8-9

Section 5

2ND RECEIVER OPERATION

Pages 10-11

1 Make sure you have everything you need.

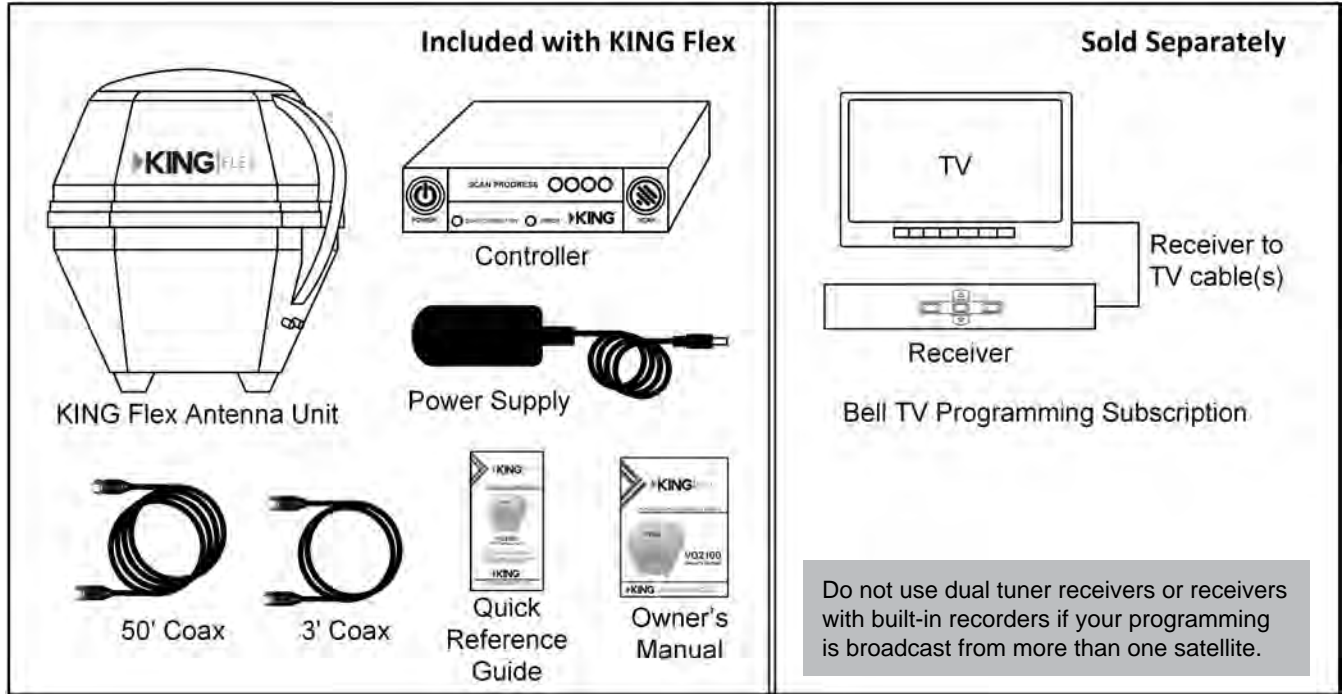

2 Place KING Flex in position.

Place the KING Flex on a stable surface. With its built-in leveling feature, the KING Flex does not need to be level, but make sure it is stable to prevent movement during operation.

NOTE: When placing the KING Flex on the ground, be sure ground is dry and free of loose dirt or sand. Do not place in an area where water may potentially pool or where water does not drain properly. The KING Flex may need to be above ground, such as on a platform, table, etc. Failure to follow these instructions may void the warranty.

IMPORTANT! Do not block the antenna's line of sight to satellites in the southern sky at any time.

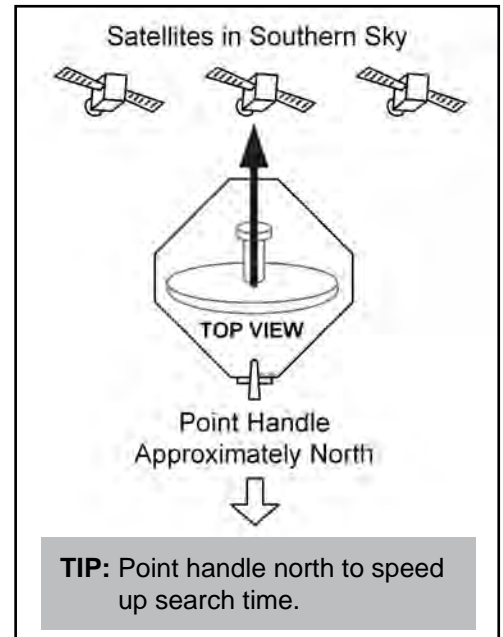

3 Make connections A-D in order shown on opposite page.

IMPORTANT! HAND TIGHTEN COAX CONNECTIONS. DO NOT USE A WRENCH.

Do not allow the coax cable to become bent or kinked.
Do not leave the coax cable where it can be tripped on or run over by a vehicle.

4 Go to Page 4.

KING Flex Antenna Unit
(located outside)

**AVOID SHARP BENDS
WHEN ROUTING COAX!**

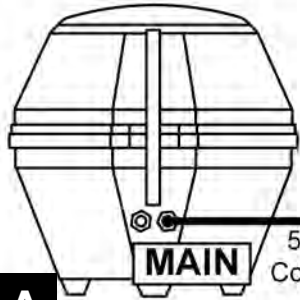

Back of KING Flex Controller

ANT

50' RG-6
Coax Cable

A

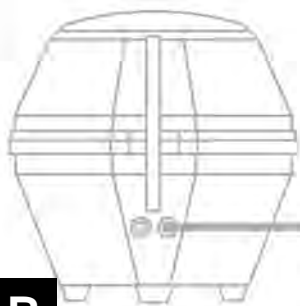

REC

3' RG-6 Coax Cable

Sold separately

TV

Cable(s)

SAT IN

Receiver

B

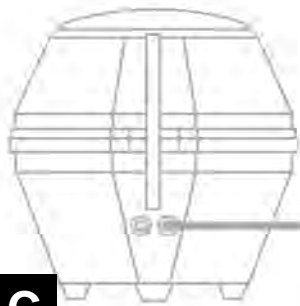

110-120 VAC

Power
Supply

PWR

C

If using a second receiver, it will be
connected in Section 5 on page 10.

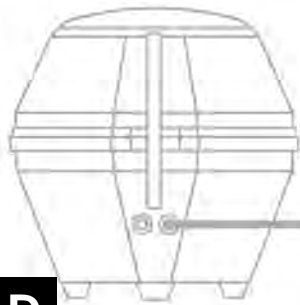

110-120 VAC

D

ANTENNA CONFIGURATION

You must configure the antenna to work with your Bell TV satellite service. Doing this will allow the KING Flex to lock on the correct satellites to receive your programming and also enable automatic satellite switching via the receiver's remote control for multi-satellite service.

Antenna configuration is a one time procedure that **MUST BE COMPLETED** before using your KING Flex antenna. To configure your antenna, do the following:

1. Press **POWER** to turn on KING Flex controller. The **COAX CONNECTION** light will flash 10 times and then turn on, and the **SCAN PROGRESS** lights will flash 3 times to indicate the selected service configuration.
2. Simultaneously press and hold **POWER** and **SCAN** for five seconds.

The **COAX CONNECTION** light and the **SCAN PROGRESS** lights that indicate the currently selected service will begin flashing.

3. Press **SCAN** repeatedly to scroll thru the available service provider options.

SATELLITE SERVICE CHART

Service	Satellites	Light 1	Light 2	Light 3	Light 4
DIRECTV SD	101	●	○	○	○
DIRECTV SD with Local	101, 119	●	●	○	○
DISH SD	110, 112	●	○	●	○
DISH SD and HD	110, 119, 123	●	●	●	○
DISH SD and HD Alternate	215, 110, 123	●	○	●	●
BELL SD	91	○	●	○	○
BELL SD and HD	82, 91	○	●	●	○
TAILGATER MODE	110, 119, 123	○	●	●	●

○ = OFF ● = ON

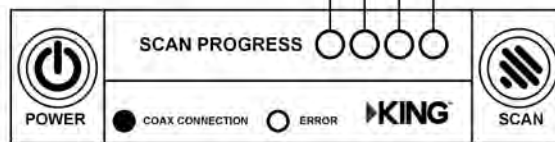

NOTE: To verify the current service configuration without changing it, perform steps 1-2 and 4-6.

4. When the correct lights turn on to show your desired satellite configuration, simultaneously press and hold **POWER** and **SCAN** for five seconds.

Your antenna configuration will be saved. All **SCAN PROGRESS** lights will turn off and the **COAX CONNECTION** light will continue to flash.

The unit will now enter Alarm Configuration mode.

ALARM CONFIGURATION

After entering Alarm Configuration Mode using the previous steps, audible beeping will confirm the alarm condition:

Single Beep (beep...beep...beep).....Alarm is **OFF**.

Double Beep (beep beep...beep beep)Alarm is **ON**.

5. Press and release **SCAN** to toggle between the on and off conditions. Beep pattern will change to indicate new condition.
6. When alarm is in desired condition, press **POWER** and **SCAN** for 5 seconds to exit Alarm Mode. Alarm condition will be saved. **COAX CONNECTION** light will turn solid and **SCAN PROGRESS** lights will stay off.

Notes on Alarm Feature

When alarm is enabled: If the coax cable is disconnected from the antenna unit or the controller while the system is turned on or in standby mode, the controller will sound an audible alarm.

To turn off the alarm when it is sounding, press **POWER** until the controller turns off.

This unit is shipped from the factory with the alarm feature in the ON condition.

If you wish to change the alarm from its previous state, perform steps 1-2 and 4-6 on these two pages.

7. Go to RECEIVER CONFIGURATION on next page.

Section 3 RECEIVER CONFIGURATION

IMPORTANT! YOU MUST HAVE COMPLETED THE ANTENNA CONFIGURATION ON PAGES 4-5 BEFORE CONTINUING BELOW.

NOTE: If you do not have a clear view of the satellites, the switch will not load correctly.

The SW21 switch is a receiver software configuration that is loaded into the receiver after successfully running a check switch test with the dish locked on and configured for the appropriate service.

This one time procedure will not need to be repeated after successful installation, unless:

- check switch test is run again while the receiver is connected to a home dish system.
- check switch test is run when the receiver is not connected.
- you are parked in an area where the selected satellites are blocked, but are able to select alternate satellites and get signal.

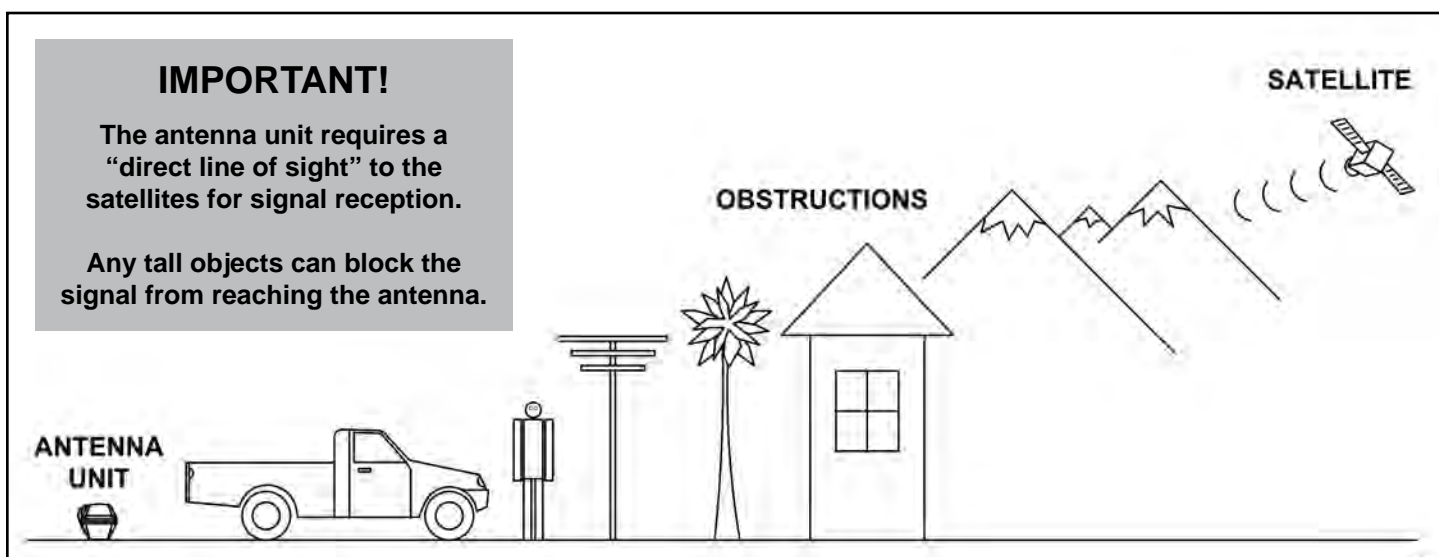

1. Turn on the TV and satellite receiver.
2. Your KING Flex controller should be on from the configuration process on pages 4-5. If not, press **POWER** and wait for the **COAX CONNECTION** light to remain on.

Press and hold **SCAN** for 3 seconds.

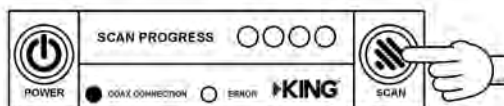

The antenna will locate all of the appropriate satellites before completing the search process.

After the antenna acquisition process is complete, specific SCAN PROGRESS lights will turn on to indicate which satellites have been found (see chart on page 9).

NOTE: Because receivers are always changing, screen graphics may vary.

3. On the receiver remote, press **MENU, 6, 1, 1**.

4. Highlight "Check Switch."

Press **SELECT** on your remote.

NOTE: Some receivers may prompt you to select "Check Switch" a second time to initiate the test.

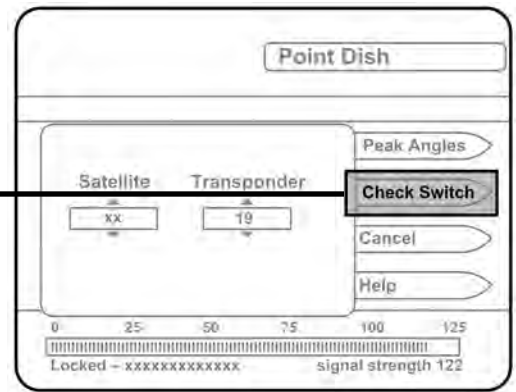

5. Make sure "SuperDISH" and "Alternate" boxes are **NOT** selected.

NOTE: Not all receivers will display a screen with options that include "SuperDISH" and "Alternate" boxes.

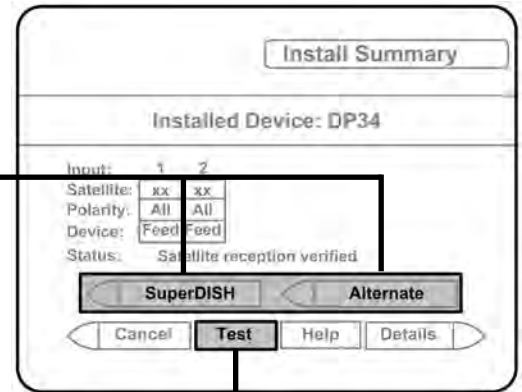

6. Highlight "Test."

Press **SELECT** on your remote.

The receiver will perform a check switch test. This process can take a little while so PLEASE BE PATIENT.

7. When test is complete, a screen similar to one below should appear.

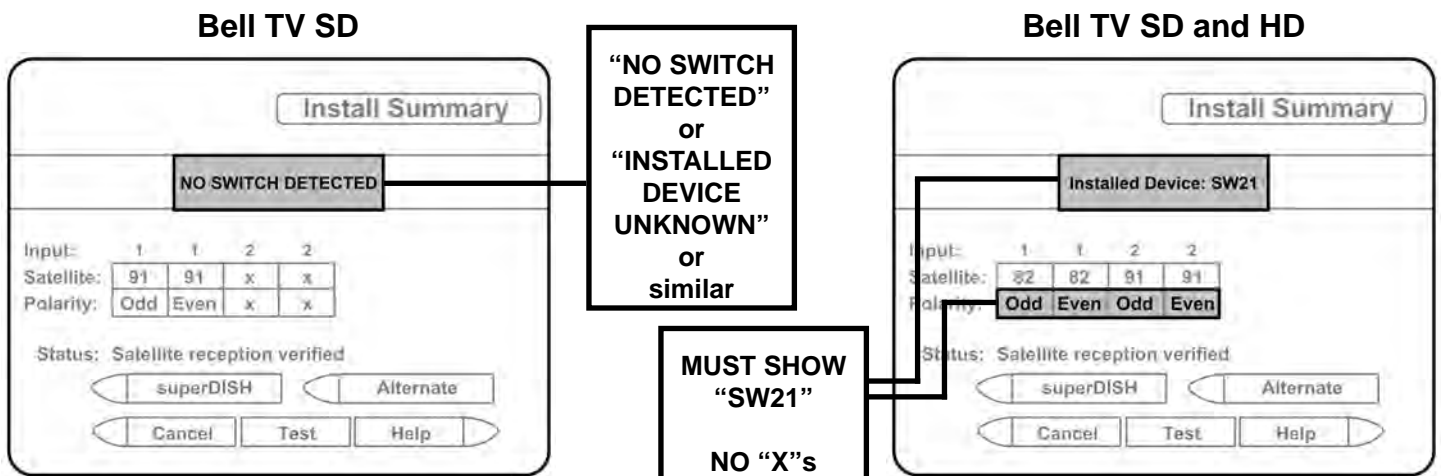

If the indicated results are not obtained, go back to Step 3 and run test again. Contact KING if the check switch fails to load after 4 attempts.

8. When the installation summary shows the successful check switch test results, save the settings, exit to the main menu screen and wait for programming to download.

9. Configuration is complete. Go to page 8, OPERATION.

Section 4 OPERATION

NOTE: Dual tuner receivers or receivers with built-in recorders are not recommended and will not have full functionality when used with the KING Flex antenna. Your local channels may not be available when traveling outside your home area.

IMPORTANT!

The antenna unit requires a “direct line of sight” to the satellites for signal reception.

Any tall objects can block the signal from reaching the antenna.

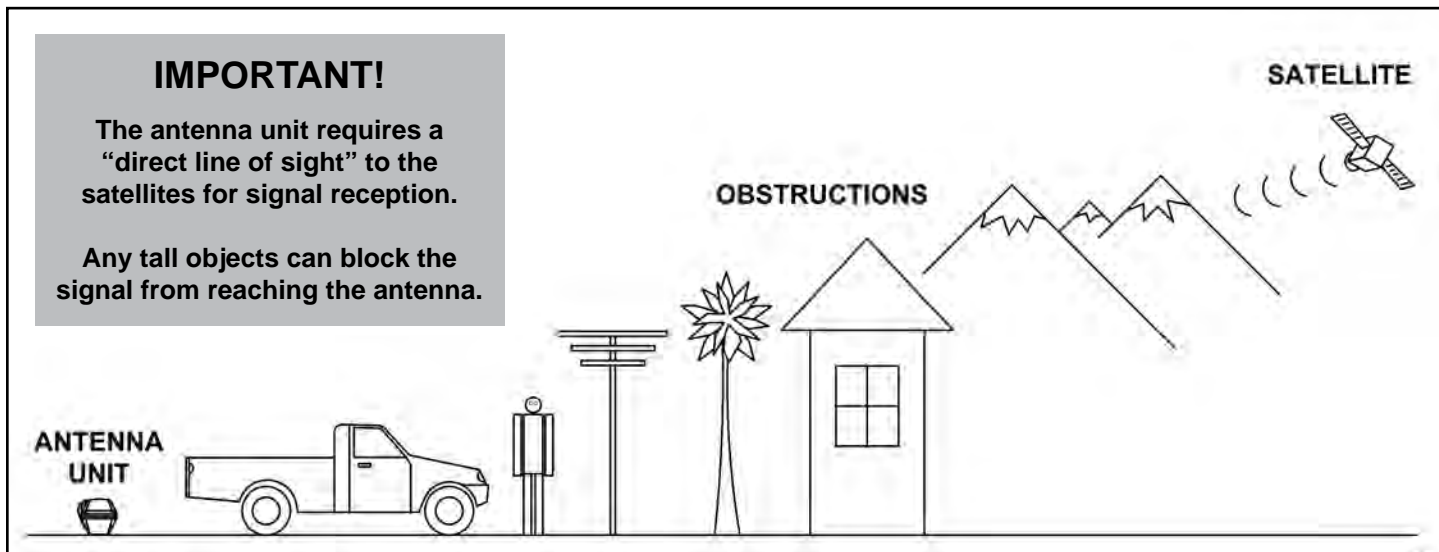

POWER UP

1. Make sure all connections are made as shown on page 3.

2. Press **POWER** to turn on KING Flex controller.

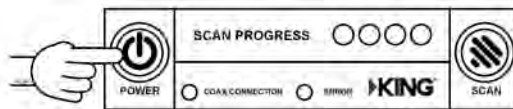

- All lights turn on briefly.
- The **COAX CONNECTION** light flashes 10 times.
- The **SCAN PROGRESS** lights flash 3 times to indicate the currently selected service configuration and then turn off.
- If the unit is operating properly, the **COAX CONNECTION** light will remain on and all other lights will turn off.

3. Turn the TV and satellite receiver on.

- Antenna is now ready to scan for satellites. Go to next page.

SCAN FOR SATELLITES

4. Press and hold **SCAN** for 3 seconds.

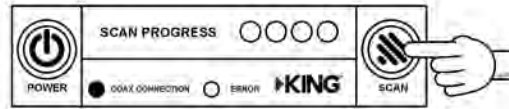

- The antenna will scan for the selected satellites. The four **SCAN PROGRESS** lights will cycle on and off to indicate a scan is in progress.
- As satellites are located, the corresponding **SCAN PROGRESS** lights will turn on (see below).
- When scan is complete, the appropriate lights will turn on to show which satellites were found.
- Wait for the program guide to download and then select your desired channel.

“SATELLITES FOUND” CHART

Service	Satellites	Light 1	Light 2	Light 3	Light 4
Bell SD	91	●	○	○	○
Bell SD and HD	82, 91	●	●	○	○

○ = OFF ● = ON

NOTE: Light 1 = Satellite 91, Light 2 = Satellite 82

NOTE: If you move the antenna unit, you will have to re-acquire the satellites by repeating the scan process. The KING Flex will go into “sleep mode” after 15 minutes and the **COAX CONNECTION** light will dim. Press **POWER** to wake unit up if necessary, i. e. the unit is in sleep mode, you move the unit, and wish to rescan for satellites.

To turn the unit off at any time, press **POWER** for 3 seconds.

If you are using a second receiver, see **SECOND RECEIVER OPERATION** on page 10.

INITIAL SETUP FOR SECOND RECEIVER

1. With the second receiver disconnected from the antenna unit's AUX port coax, use your DISH remote control and press **MENU, 6, 1, 1** to display the *Point Dish* screen.

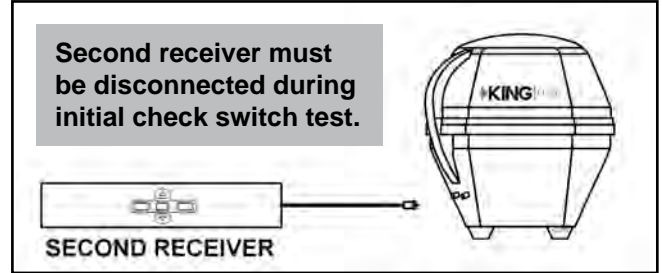

2. Use the arrow buttons on the remote to highlight "Check Switch."

Press **SELECT** on your remote.

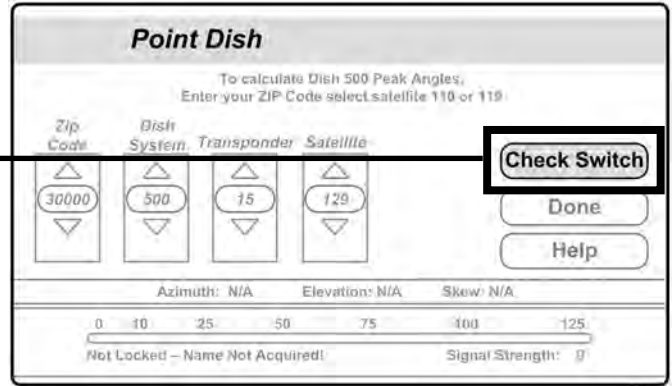

3. Verify "SuperDISH" and "Alternate" are not selected.

Verify "Test" is highlighted.

Press **SELECT** on your remote.

Wait for check switch test to finish.

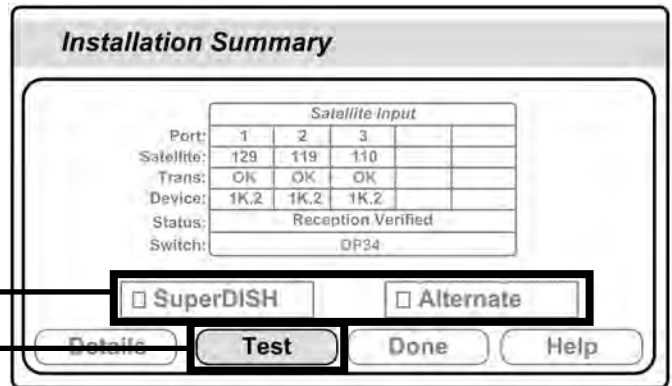

4. Connect second receiver to antenna unit's MAIN port and run check switch again using steps above.

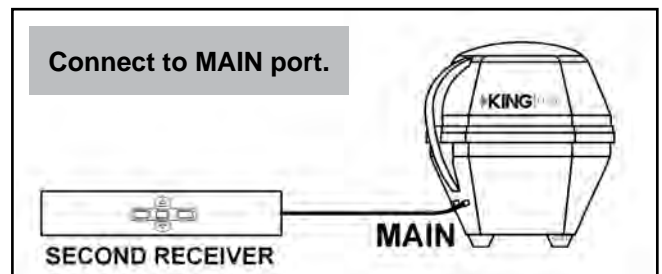

5. When test is complete, highlight "Save."

Press **SELECT** on your remote.

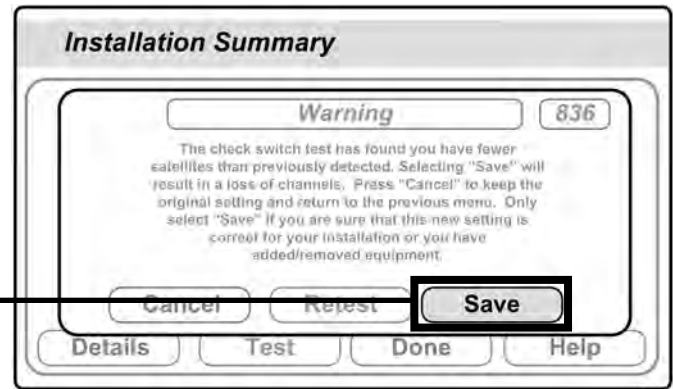

6. After successfully saving the results, connect the second receiver to the AUX port.

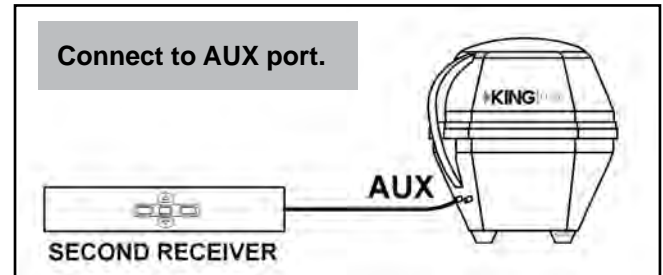

DOWNLOADING PROGRAMMING TO THE SECOND RECEIVER

1. With the second receiver now connected, and the antenna locked on (see OPERATION section), re-set the second receiver by pressing the POWER button on the front panel for 10 seconds. The TV picture will go away and should reappear within two minutes.

The receiver will then download the program guide to show only the channels available on the current satellite as determined by the channel selected on the main receiver. Downloading the new program guide can take up to five minutes to complete.

The channels available on the second receiver are determined by the channel/satellite selected on the main receiver. For example, if you select a channel on the main receiver that is broadcast from the 82 satellite, then the second receiver will be able to display any channel broadcast from the 82 satellite.

If you switch channels on the main receiver to one that is broadcast from a different satellite, (i.e. your channel was broadcast from satellite 82 but your new channel is broadcast from the 91), the antenna will automatically switch to the new satellite and programming will be lost on the second receiver until you either:

- Select a channel on the main receiver that is broadcast from the previous satellite (satellite 82 in this example).

(or)

- Reset the second receiver to download the program guide for the newly selected satellite (satellite 91 in this example).

APPENDIX

Section 1

TROUBLESHOOTING

Page 2

Section 2

MOUNTING BRACKETS

Page 3

Section 3

SECURITY FEATURE

Page 4

Section 4

FCC GUIDELINES

Page 4

Section 5

LIMITED WARRANTY

Page 5

Section 1 **TROUBLESHOOTING**

SYMPTOM	POSSIBLE CAUSE	COURSE OF ACTION
No lights turn on.	No power to controller.	<p>Verify power supply is properly connected to KING Flex controller.</p> <p>Verify power supply is plugged into a 110-120 VAC power source.</p>
ERROR light and all 4 SCAN lights flash slowly.	No satellites found.	<p>Line of sight obstructions. Move unit to have a better view of southern sky and rescan.</p> <p>Inclement weather can occasionally cause loss of signal. Wait till weather improves and rescan.</p> <p>Unit was bumped or moved during scan. Make sure unit is stable and rescan.</p> <p>If problem persists, call KING Service at (952) 922-6889.</p>
ERROR light and COAX CONNECTION light both flash quickly.	<p>Coax between antenna unit and KING Flex controller not connected.</p> <p>Coax between antenna unit and KING Flex controller faulty.</p> <p>Coax from KING Flex controller connected to wrong port (AUX) on antenna unit.</p> <p>Coax between main circuit board and output port on antenna unit faulty.</p>	<p>Connect coax between antenna unit and KING Flex controller.</p> <p>Replace coax (KC# 20993).</p> <p>Connect coax from KING Flex controller to MAIN port on antenna unit.</p> <p>Call KING Service at (952) 922-6889.</p>
Scan is not complete after 15 minutes.	Antenna is not moving.	Call KING Service at (952) 922-6889.

Section 2 MOUNTING BRACKETS

NOTE: All brackets sold separately. For more information call KING at (952) 922-6889 or visit www.kingcontrols.com.

The KING Flex may be permanently mounted to a vehicle using the MB150 Mounting Bracket.

MB150 Vibration Isolation Mounting Bracket



The KING Flex may be temporarily mounted to a cab or other vertical surface using the MB300 and MB350 Mounting Brackets.

MB300 - Window Bracket Kit

Allows the King Flex to be temporarily hung on vertical surfaces such as the window of your vehicle.

(Sold separately from MB350)

(2) Removable clear vinyl stickers to protect windows



Window bracket

Foam block w/adhesive strip



MB350 - Cab Mounting Plate

Attach to cab or other vertical surface to add temporary mounting location for KING Flex using MB300 mount.

(Sold separately from MB300)

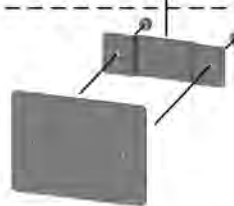

IMPORTANT!
KING Flex must not be on bracket while vehicle is in motion.

The KING Flex may be semi-permanently mounted to a vehicle while parked using the MB400 Mounting Bracket.

MB400 Ladder Mount Bracket

IMPORTANT!
KING Flex must not be on bracket while vehicle is in motion.



NOTE: If you already have the MB100 or MB101 Mounting Bracket, a kit is available (MB100-RETROFIT) to add vibration isolation to your existing bracket without removing it from the truck cab.

The MB100 and MB101 VuQube Mounting Brackets are NOT compatible with the KING Flex without the use of the MB100-RETROFIT Kit. **USE OF THESE BRACKETS WITHOUT THE MB100-RETROFIT KIT WILL VOID THE PRODUCT WARRANTY.**

Section 3 SECURITY FEATURE

The KING Flex can be secured to an object using a padlock and cable (not included) to deter theft.

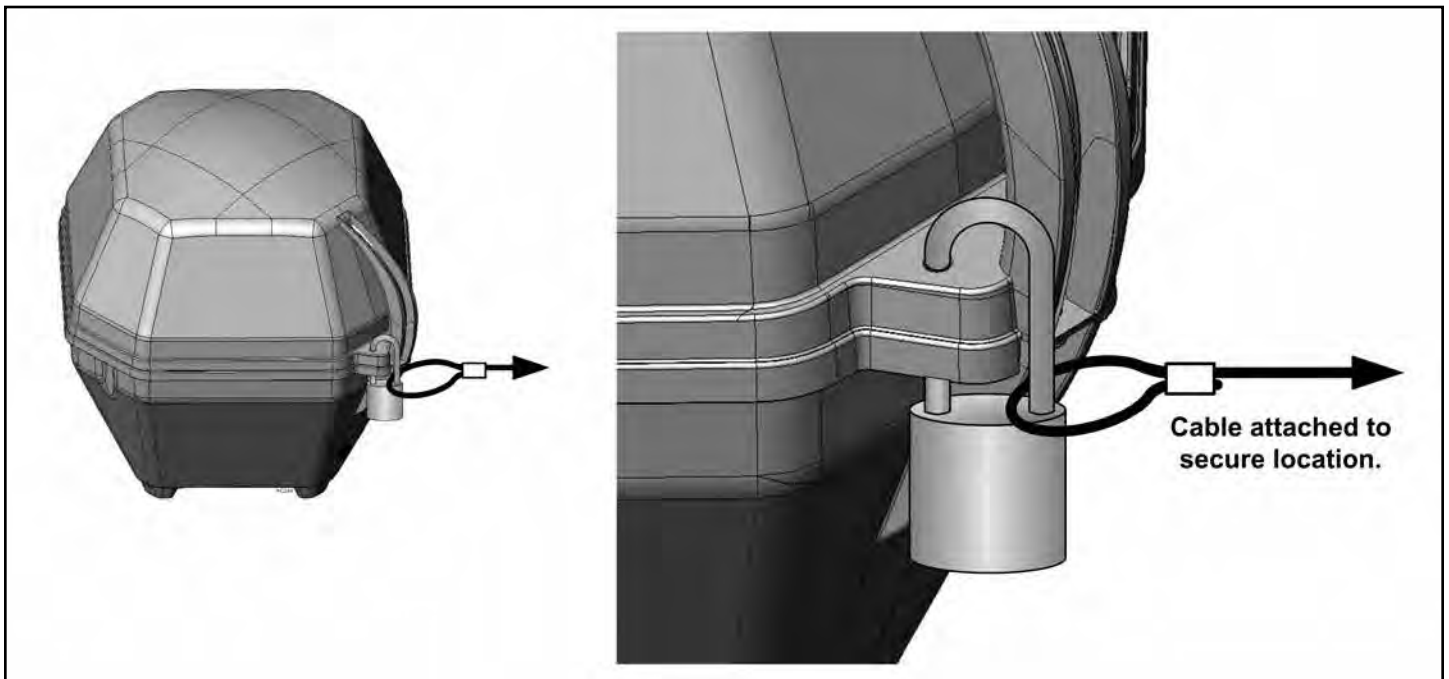

Section 4 FCC GUIDELINES

This device complies with Part 15, sub-part B, of the FCC Rules. Operation is subject to the following two conditions:

- 1) This device must not cause harmful interference, and
- 2) This device must accept any interference received, including interference that may cause undesired operation.

Section 5 LIMITED WARRANTY

Every new KING Flex Satellite System is thoroughly inspected and tested before leaving the factory, and is covered by the following one year parts limited warranty from the date of original purchase:

- One year parts warranty: The customer is not responsible for the cost of replacement parts if the original part is determined to be defective under the terms of the warranty. The customer is responsible for the cost of replacement parts after one year.

Should any trouble develop during the warranty period, contact KING. You must contact KING before the warranty period expires. The customer must supply proof of purchase (such as a dated sales receipt) when requesting warranty service. If the customer cannot supply proof of purchase, warranty period shall start 30 days after date of manufacture.

Only KING may perform warranty evaluations and repairs.

If it is determined that the unit needs to be returned to KING, customer must return COMPLETE product, freight prepaid, to: **KING, 11200 Hampshire Avenue South, Bloomington, MN 55438-2453.**

If inspection shows the trouble is caused by defective workmanship or material, KING will repair (or at its option, replace) without charge.

When returning product, KING will supply an RMA number (Return Merchandise Authorization). This number must be clearly written on the box. Failure to clearly write RMA number on box may result in delays in processing claim. Along with product, the customer should include in the box: his/her name, address, daytime phone number, proof of purchase and description of the problem.

This warranty does not cover installation and external wiring, or re-manufactured units. This warranty does not cover damage caused by the use of a mounting bracket other than a KING mounting bracket specifically designed for this product by KING. This warranty is not transferable from the original owner.

Due to the expanding and changing TV market, KING cannot be held responsible for changes made to satellite services. Software updates to address such issues are not covered under warranty.

This warranty also does not apply where:

- The product has been abused, misused, improperly installed or improperly maintained.
- The product has been installed without the use of a KING mounting bracket designed for the product by KING.
- Repairs have been made or attempted by others that are not certified by KING to do such repairs.
- Repairs are required because of normal wear and tear.
- Alterations have been made to the product.
- The antenna unit has been opened without authorization.
- Damage has been caused by power washing.
- Supplied grease not used in the external coax connections as specified in the instructions (non-portable units).
- Circumstances beyond the control of KING cause the product to no longer operate correctly.
- Customer is not the original owner.

In no event shall KING be liable for any indirect, incidental, or consequential damages from the sale or use of the product. This disclaimer applies both during and after the term of the warranty.

KING disclaims liability for any implied warranties, including implied warranties of “merchantability” and “fitness for a specific purpose,” after the one year term of this warranty.

This warranty gives you specific legal rights, and you may also have other rights, which vary from state to state. Some states do not allow the exclusion or limitation of incidental or consequential damages, so the above limitation or exclusion may not apply to you. Some states do not allow limitations on how long an implied warranty lasts, so the above limitation may not apply to you.



11200 Hampshire Avenue South, Bloomington, MN 55438
PH 952.922.6889 || FAX 952.922.8424 || kingcontrols.com

21438 Rev D