

Emergency Locator Transmitter

INSTALLATION MANUAL OPERATION MANUAL



KANNAD 406 AP-H

P/N : S1820502-04

P/N : S1820511-01

P/N : 0124206

KANNAD 406 AP-H transmitter

Mounting bracket, 1 strap

ANT100, auxiliary antenna

Users are kindly requested to notify **KANNAD** of any discrepancy,
omission or error found in this manual.

Please report to our customer support:

E-mail: support.sar@kannad.com

Tel.: +33 (0)2 97 02 49 00

RECORD OF REVISIONS

REV. Nb	REVISION DATE	INSERTION DATE	BY
00	OCT 18/2006	OCT 18/2006	J. S.
01	FEB 13/2008	FEB 13/2008	J. S.
02	SEP 12/2008	SEP 12/2008	J. S.
03	APR 30/2010	APR 30/2010	J. S.

RECORD OF REVISIONS

PAGE INTENTIONALLY LEFT BLANK

LIST OF EFFECTIVE PAGES

SUBJECT	PAGE	DATE
Title Page		
TP	1	APR 30/2010
Record of Revisions		
ROR	1	APR 30/2010
ROR	2	APR 30/2010
List of Effective Pages		
LEP	1	APR 30/2010
LEP	2	APR 30/2010
Table of Contents		
TOC	1	APR 30/2010
TOC	2	APR 30/2010
TOC	3	APR 30/2010
TOC	4	APR 30/2010
Introduction		
INTRO	1	SEP 12/2008
INTRO	2	SEP 12/2008
System Overview		
	1	SEP 12/2008
	2	SEP 12/2008
	3	APR 30/2010
	4	SEP 12/2008
	5	SEP 12/2008
	6	APR 30/2010
	7	APR 30/2010
	8	APR 30/2010
System Functional Description and Operation		

LIST OF EFFECTIVE PAGES

SUBJECT	PAGE	DATE
Installation / Removal	101	SEP 12/2008
	102	SEP 12/2008
	103	SEP 12/2008
	104	SEP 12/2008
	105	SEP 12/2008
	106	SEP 12/2008
	107	SEP 12/2008
	108	SEP 12/2008
	109	SEP 12/2008
	110	SEP 12/2008
	Check	201
202		SEP 12/2008
203		APR 30/2010
204		APR 30/2010
205		SEP 12/2008
206		SEP 12/2008
207		APR 30/2010
208		APR 30/2010
209		APR 30/2010
210		APR 30/2010
	301	SEP 12/2008
	302	SEP 12/2008
	303	SEP 12/2008
	304	SEP 12/2008

LIST OF EFFECTIVE PAGES

SUBJECT	PAGE	DATE
Troubleshooting	401	SEP 12/2008
	402	SEP 12/2008
Schematics and Diagrams	501	SEP 12/2008
	502	SEP 12/2008
	503	SEP 12/2008
	504	APR 30/2010
	505	APR 30/2010
	506	APR 30/2010
	507	APR 30/2010
	508	APR 30/2010
Servicing	601	APR 30/2010
	602	SEP 12/2008

LIST OF EFFECTIVE PAGES

PAGE INTENTIONALLY LEFT BLANK

TABLE OF CONTENTS

INTRODUCTION	1
SYSTEM OVERVIEW	1
COSPAS-SARSAT System	1
Description	1
World coverage with the COSPAS-SARSAT system	2
Environmental improvements of ELTs	2
G-Switch (shock detectors)	2
KANNAD 406 AP-H Presentation	3
LINE REPLACEABLE UNITS	4
Transmitter	4
Bracket	4
Remote Control Panel	4
External antenna	4
Design features	5
Compatibility list	6
Remote control panels (RCP)	6
DIN-12 connector or programming dongles	6
ELT-NAV System Interface	6
External antennas	7
SYSTEM FUNCTIONAL DESCRIPTION AND OPERATION	101
Transmitter	101
Controls	102
Working mode information	103
Off	103
Self-Test	103
Armed	104
On	104
Autonomy	105
Electrical characteristics	106
Electrical interface	106
Technical Specifications	107
Activation	108
Standby mode for automatic activation	108
Manual activation as fixed ELT	108
Manual activation as survival ELT	108
Reset	109
Manual reset	109
Reset with Remote Control Panel	109
Self-Test	109
INSTALLATION / REMOVAL	201
Registration and Programming	201
Pin programming option	201

TABLE OF CONTENTS

ELT Installation	203
Installation recommandations	203
FAA Recommendations	203
TSO C126a Section 5 b. Application Data Requirements	203
RTCA DO-182 Recommandations	203
RTCA DO-204a Requirements	203
Bracket installation	204
Transmitter and auxiliary antenna installation	206
Antenna Installation	207
Antenna Installation Recommendations	207
FAA Recommendations	207
RTCA DO-204 Requirements for ELT location	207
Antenna installation procedure	207
RCP Installation (if any)	209
ELT connection	209
First power up	209
Removal	210
CHECK	301
Self-test	301
Periodicity	301
Self-test procedure	301
ELT operational tests	302
Installation without programming dongle	302
Installation with Programming Dongle	302
RCP operational tests	303
406 and 121.5 MHz transmission test	304
ELT-Antenna link	304
406 MHz	304
121.5 MHz	304
TROUBLESHOOTING	401
General	401
Faults on Self-test	401
Visual indicator	401
3+1 flashes	401
3+2 flashes	401
3+3 flashes	401
3+4 flashes	401
Other faults detected	401
Buzzer	401
Buzzer does not operate	401
Buzzer operates permanently when ELT in ARM mode	401
SCHEMATICS & DIAGRAMS	501

TABLE OF CONTENTS

Outline Dimensions	501
Drilling Mask	502
Wiring	503
ANT AV200, outline dimensions and drilling mask	504
ANT AV300, outline dimensions and drilling mask	505
ANT300, outline dimensions and drilling mask	506
ANT 410, outline dimensions and drilling mask	507
SERVICING	601
Maintenance Schedule	601
Periodic inspection	601
Every 6 years	601
Battery replacement	602

TABLE OF CONTENTS

PAGE INTENTIONALLY LEFT BLANK

INTRODUCTION

The instructions in this manual provide the information necessary for the installation and the operation of KANNAD 406 AP-H ELT.

Servicing instructions ([Refer to SERVICING page 601](#)) are normally performed by shop personnel.

For servicing and maintenance instructions, refer to CMM 25-63-01.

For regulatory requirements, please consult your national aviation authority.

PAGE INTENTIONALLY LEFT BLANK

SYSTEM OVERVIEW

1. COSPAS-SARSAT System

A. Description

Launched in the early eighties by the four founder countries (Canada, France, Russia, USA), the COSPAS-SARSAT system provides satellite aid to search and rescue (SAR) operations for maritime, aeronautical and terrestrial vehicles anywhere in the world.

It uses distress beacons fitted on mobiles and a constellation of LEO and GEO satellites which relay the 121.5 / 243 MHz signals and process the 406 MHz signal to ground stations (LUT) where the beacon positions are determined (with a precision of 10 NM with 121.5 / 243 signals and less than 2 NM with 406 signals).

Several types of beacons are designed to match the various applications of the COSPAS-SARSAT system:

- EPIRB (Emergency Position Indicating Radio Beacon) for maritime applications.
- ELT (Emergency Locator Transmitter) for aeronautical applications.
- PLB (Personal Locator Beacon) for land expeditions.

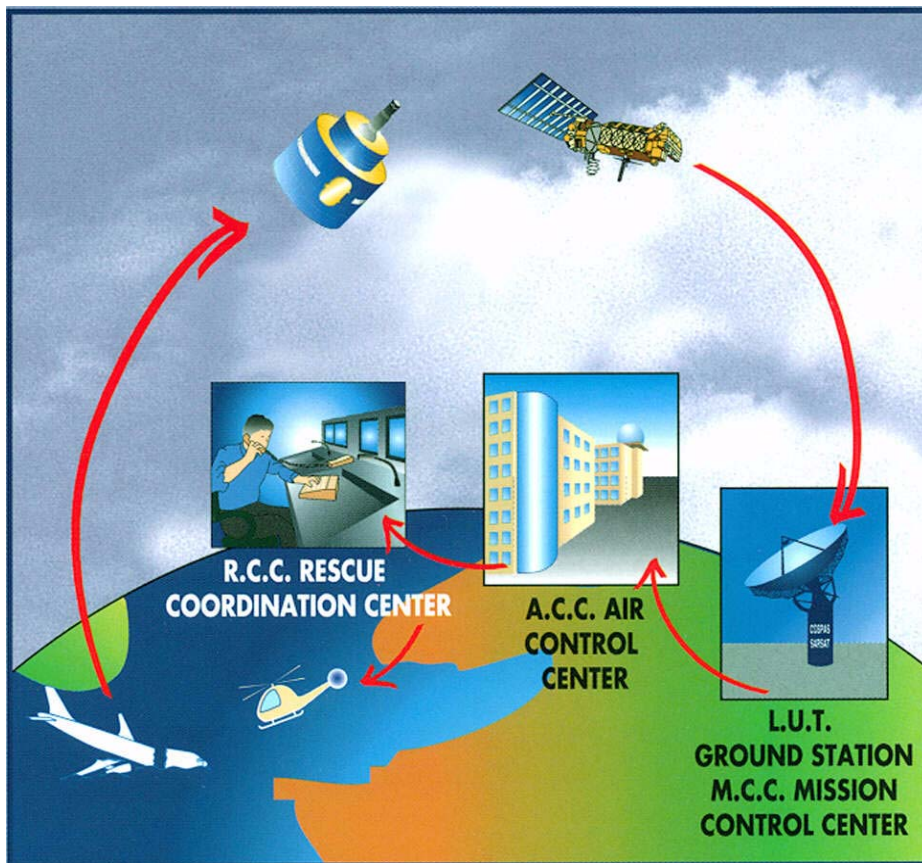

Figure 1: COSPAS-SARSAT System

B. World coverage with the COSPAS-SARSAT system

The major improvement is the use of the COSPAS-SARSAT system for processing aeronautical emergencies.

The difference with the 121.5 / 243 MHz is that the 406 MHz transmission carries digital data which enable the identification of the aircraft in distress and facilitate SAR operation (type of the aircraft, number of passengers, type of emergency).

The 406 MHz message is transmitted to the COSPAS-SARSAT satellites. This message is downloaded to one of the 64 ground stations (44 LEOLUTs and 20 GEOLUTS).

The aircraft is located by Doppler effect by the LEO satellites with a precision better than 2 NM (4 km) at any point of the earth.

C. Environmental improvements of ELTs

The certification of an ELT includes a range of severe mechanical tests:

- resistance to flame;
- impact and crush tests;
- resistance to 100 G and 500 G shocks;
- watertightness;
- antideflagration;
- extreme temperatures (-20°C to 55°C for more than 48 hours).

D. G-Switch (shock detectors)

The shock detectors equipping old automatic ELTs are the cause of a large number of false alarms. Major work has consisted in studying aircraft crashes (study made by the " Crash Research Institute ") and evaluating the acceleration amplitudes involved. As a consequence, G-Switch specifications have been modified to optimize the accuracy of the crash detection.

2. KANNAD 406 AP-H Presentation

The KANNAD 406 AP-H belongs to the AP type of ELTs which are intended to be rigidly attached to the aircraft before the crash, but readily removable from the aircraft after a crash.

The KANNAD 406 AP-H is designed to be installed **on helicopters only**.

The KANNAD 406 AP-H is composed of:

1. a transmitter;
2. a mounting bracket;
3. a remote control panel (mandatory if ELT controls are not available from the pilot's position, refer to RTCA/DO-183, RTCA/DO-204, EUROCAE ED-62);
4. an outside antenna;
5. a "Programming Dongle" for pin-programming function (option);
6. CS144 Interface Module (option);
7. an auxiliary antenna (for use as a survival beacon).

The transmitter, bracket, Programming Dongle and CS144 Interface Module are installed in the aircraft near the tail. The outside antenna is mounted on the fuselage near the tail. The remote control panel is installed in the cockpit and connected to the ELT with a 4 or 5 wire bundle.

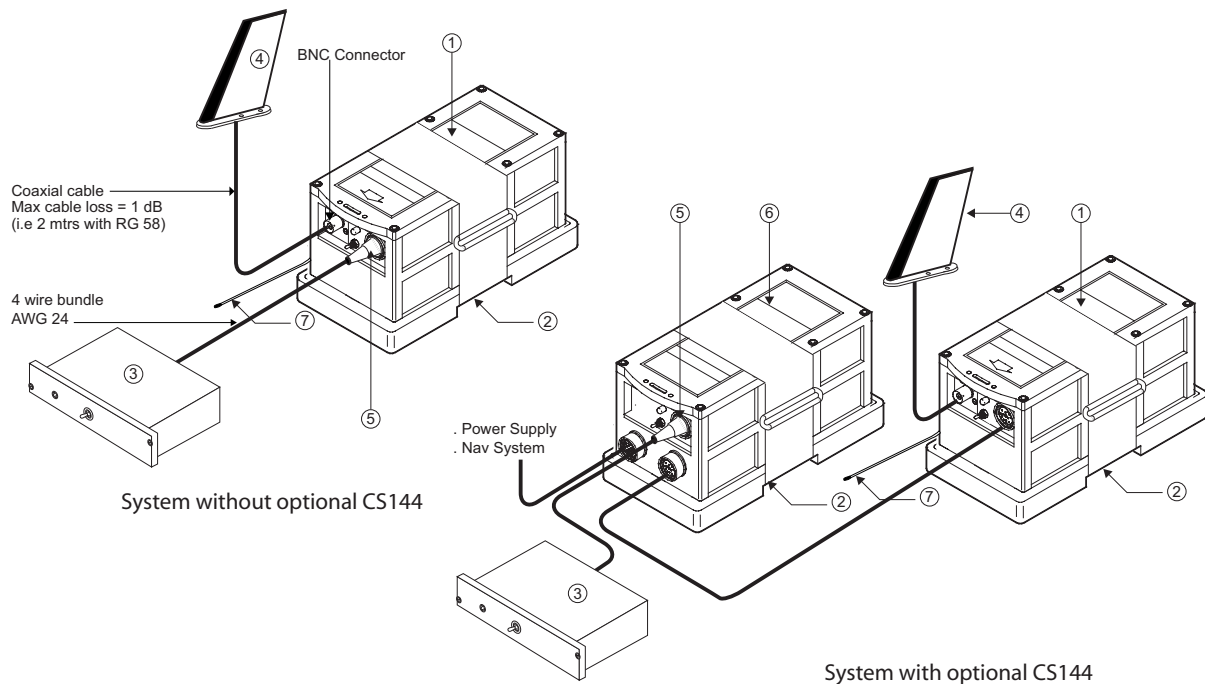

Figure 2: ELT system description

3. LINE REPLACEABLE UNITS

A. Transmitter

The KANNAD 406 AP-H is an ELT designed to be installed on board helicopters to transmit a distress signal on 3 frequencies:

- 406 MHz (COSPAS-SARSAT frequency) for precise pinpointing and identification of the aircraft in distress.
- 121.5 and 243 MHz used for homing in the final stages of the rescue operations.

It is certified as an Automatic Portable (AP) ELT and works with a three frequency outside antenna when installed on board the aircraft or with a small whip antenna (auxiliary antenna) when used as a survival ELT.

B. Bracket

The bracket installed near the tail is designed to fix the ELT with a Velcro® strap. This enables quick removal of the ELT for maintenance or exchange.

C. Remote Control Panel

A remote control panel can be supplied for installation in the cockpit in order to enable the pilot to monitor and control the ELT status.

The following controls are to be found on the panel:

- 3-position switch (ON, ARMED, RESET&TEST);
- red or amber visual indicator;
- beeper (on certain versions).

The remote control panel is connected to the ELT via a 4 or 5-wire cable equipped with a "Programming Dongle" or a DIN 12 connector on the ELT side and the connector corresponding to the Remote Control Panel version on the other side.

D. External antenna

The external antenna, also installed near the tail, can be either rod or blade type according to aircraft speed.

Connection to the ELT will be carried out with a 50 Ohm coaxial cable (RG58 for example) ended with a BNC connector.

IMPORTANT NOTICE: KANNAD recommends a cable with radio electric properties similar or better to those of a RG58 cable.

4. Design features

The KANNAD 406 AP-H is made of moulded plastic with excellent mechanical resistance (ASA/PC, light yellow colour).

The housing is designed with no sharp edges.

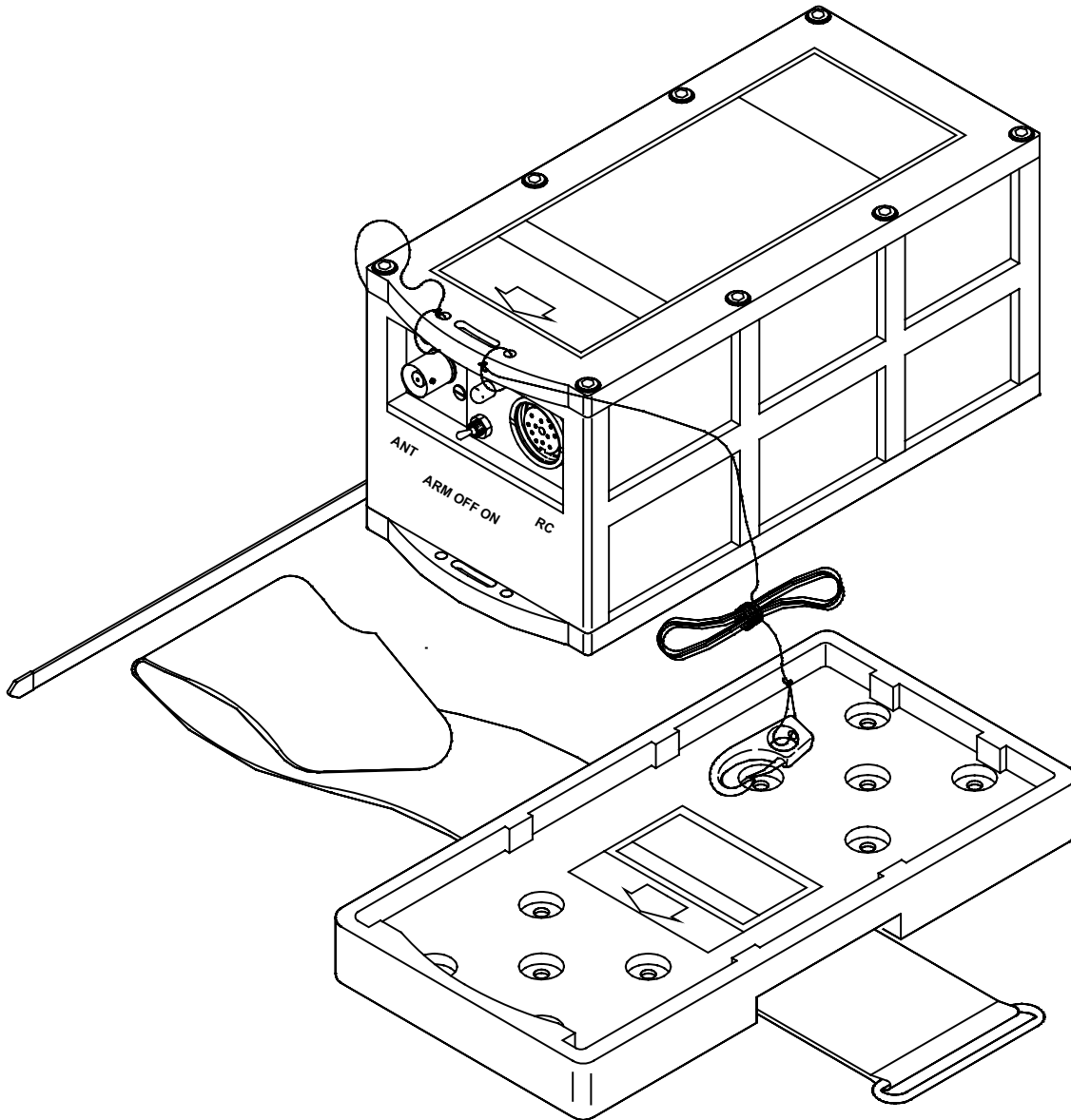

Figure 3: KANNAD 406 AP-H with mounting bracket

5. Compatibility list**A. Remote control panels (RCP)**

KANNAD Designation	KANNAD Part Number
RC100 KIT	S1820513-03
RC150 KIT	S1820513-07
RC200	S1820513-11
RC200-NVG	S1820513-14
RC300	S1820513-09
RC400	S1820513-05
RC500-320	S1820513-02
RC600 NVG (Y)	S1820513-12
RC600 NVG (W)	S1820513-13
RC800	S1820513-15

B. DIN-12 connector or programming dongles

KANNAD Designation	KANNAD Part Number
DIN-12 connector	S1820514-03
Programming dongle	S1820514-01
Programming dongle A320	S1820514-04
Programming dongle A330-340	S1820514-05
Programming dongle Assy	S1820514-06

C. ELT-NAV System Interface

KANNAD Designation	KANNAD Part Number
CS144-RS	S1825502-01
CS144-A	S1825502-02
Connecting cable for CS144-RS or CS144-A	S1825502-03

D. External antennas

KANNAD Designation	Manufacturer	KANNAD Part Number
ANT560	DAYTON GRANGER ELT 10-696-1	0145787
ANT410	DAYTON GRANGER ELT 720063	0145488
ANT300	CHELTON 1327-82	0124220
ANT AV200	RAMI AV-200	0146150
ANT AV300	RAMI AV-300	0146151
N/A	ARTEX 110-340	N/A

PAGE INTENTIONALLY LEFT BLANK

SYSTEM FUNCTIONAL DESCRIPTION AND OPERATION**1. Transmitter**

The KANNAD 406 AP-H can be activated either automatically when the crash occurs (thanks to a shock sensor) or manually (thanks to a switch on the transmitter itself or on a Remote Control Panel).

The KANNAD 406 AP-H is designed to transmit on three frequencies (121.5, 243 and 406 MHz). The two basic emergency frequencies (121.5 and 243 MHz) are mainly used for homing in the final stages of the rescue operations. The 406 MHz frequency is used by the COSPAS-SARSAT satellites for precise pinpointing and identification of the aircraft in distress.

Once activated, the transmitter operates continuously on 121.5 and 243.0 MHz with an output power of 100 mW on each frequency. The modulation is an audio frequency sweeping downwards from 1420 Hz to 490 Hz with a repetition rate of 3 Hz.

During the first 24 hours of operation, a digital message is transmitted on 406.025 MHz every 50 seconds. The output power on 406 MHz is 5 W.

The KANNAD 406 AP-H can transmit two types of messages on 406 MHz:

- 112 bits for a short message (identification only);
- 144 bits for a long message (identification + aircraft position).

The long messages are generated by a separate interface module (called CS144) connected to the ELT and either NAV equipment of the aircraft by RS232, RS422 or RS485 link or to an ARINC429 bus.

2. Controls

The following controls are to be found on the ELT front panel (from left to right):

1. 3-position switch ARM/OFF/ON;
2. Red visual indicator;
3. DIN 12 connector for connection to Remote Control Panel, CS144 interface module, dongle or programming equipment;
4. BNC connector for the antenna.

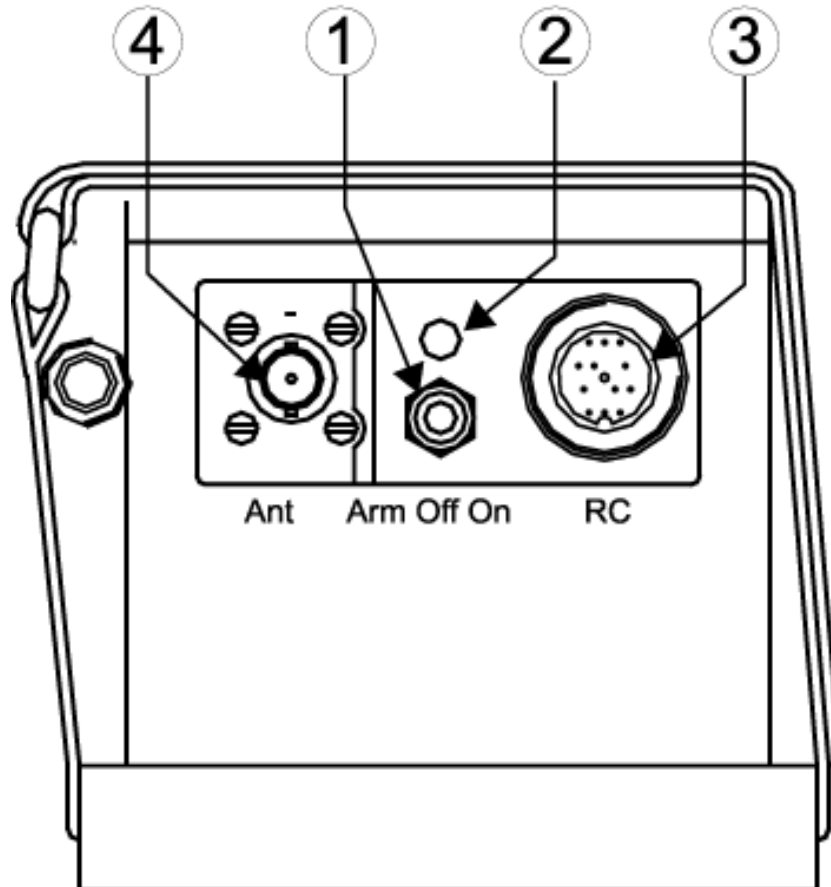

Figure 101: Front Panel

The red visual indicator gives an indication on the working mode of the beacon:

- after the self test: a series of short flashes indicate the self test failed, one long flash indicates a correct self test;
- in operating mode: periodic flashes during 121.5 / 243 transmission;
- long flash during 406 transmission.

A buzzer gives audio information on the beacon working:

- continuous tone during self test;
- 2 beeps per second during 121.5 / 243 transmission;
- silence during 406 transmission.

3. Working mode information

The KANNAD 406 AP-H has 4 different modes:

- Off.
- Self-test (temporary mode).
- Armed (standby mode to enable automatic activation by the shock sensor or by the remote control panel).
- On (transmission).

Transmission is effective if the beacon is activated (either manually on the ELT control panel, remotely by the "ON" switch on the remote control panel or automatically by the shock sensor).

A. Off

The ELT is off when the switch is in position "OFF". No part of the ELT is energized. This mode must **only** be selected when the ELT is removed from the aircraft or parked for a long period or for maintenance.

B. Self-Test

The self-test mode is a temporary mode (max duration 5 sec) in which the ELT checks the main characteristics of the transmitter (Battery voltage, Programming) and enables digital communication with a programming and test equipment.

This mode is selected:

- when switching from "OFF" to "ARM";
- when switching to "RESET / TEST" on the Remote Control Panel (provided that the switch of the ELT is in the "ARM" position);
- when switching to "ON" prior to transmission.

The buzzer operates during the self-test procedure.

After about 3 seconds, the test result is displayed on the visual indicator as follows:

- One long flash indicates valid test.
- A series of short flashes indicates false test result.

The number of flashes indicates the type of failure:

- 3 + 1 = LOW BATTERY VOLTAGE.
- 3 + 2 = LOW TRANSMISSION POWER.
- 3 + 3 = FAULTY VCO LOCKING (FAULTY FREQUENCY).
- 3 + 4 = NO IDENTIFICATION PROGRAMMED.

It is recommended to test the ELT regularly in order to detect any possible failure ([Refer to A. Periodicity, page 301](#))

The number of self-tests carried out is recorded. This information is available when the ELT is connected to a programming and test equipment (PR600).

C. Armed

In order to enable activation by the G-Switch or with the Remote Control Panel, the ELT must be in standby mode with the switch in the "ARM" position

This mode is mandatory during flight. The ELT should remain in the "ARM" position all the time except when the ELT is removed from the aircraft or parked for a long period or for maintenance.

The Remote Control Panel is energized by the ELT when switched to "ARM".

D. On

This mode is selected:

- manually by switching to position "ON";
- by switching the Remote Control Panel switch to position "ON" (provided that the ELT switch is in the "ARM" position);
- when a crash occurs (provided that the ELT switch is in the "ARM" position).

When this mode is selected, the ELT starts transmission:

- on 121.5 MHz & 243 MHz immediately (continuous transmission);
- on 406 MHz after 50 seconds (406 burst every 50 sec during 24 hours).

The red visual indicator on the ELT (and on the remote control panel if installed) flashes and the buzzer operates.

In case of accidental activation, the ELT can be reset either by switching it to "OFF" or by switching to "RESET" on the Remote Control Panel.

The number of 406 MHz bursts effectively transmitted is recorded. This information is available when the ELT is connected to a programming and test equipment (PR600).

4. Autonomy

The energy is provided by a battery pack composed of 3 LiMnO₂ D cells (See pages 107 & 602 for Kit battery reference).

Lithium cells, lithium batteries and equipment containing such batteries are subjected to regulations and classified under class 9 as from 1st of January 2003.

The autonomy of the 121.5/243 transmission is close to 100 hours at -20°C with new batteries.

In the worse conditions possible, a distress is pinpointed 5.5 hours maximum after the ELT activation and the position is subsequently updated (if necessary) every 2 hours.

As it is therefore preferable to keep the battery power for 121.5/243 MHz homing frequency transmission for the rescue operations, the 406 MHz transmission is deliberately stopped after 24 hours to extend the 121.5/243 transmission for as long as possible.

The transmitter battery expiry date is fixed at 6 years after manufacturing. If no activation of the ELT occurs during the battery lifetime, it shall be replaced every 6 years^(see note below).

NOTE: The useful life time of batteries is twelve (12) years. To be in compliance with FAR regulations, they have to be replaced every (6) years when 50 percent of their useful life has expired.

5. Electrical characteristics

Transmitter power supply: 3 x LiMnO₂ D type cells.

A. Electrical interface

When installed on board, the ELT has to be connected:

- to a Remote Control Panel via a DIN12 connector;
- to an external antenna via a BNC connector.

The DIN12 connector is also used to connect a programming dongle, a CS144 interface or a programming and test equipment.

J1

This connector is dedicated for connection to the Remote Control Panel, to the Programming or Maintenance Dongles, to a CS144 interface and/or to the programming equipment (PR600).

IMPORTANT: Shielded cables are recommended. The required wires are AWG24.

J1	PIN	Signal Name	Destination	Direction
<p>Viewed from Front Face</p> 	J1-A	RCP TEST/RESET	RCP	IN
	J1-B	DONGLE RX	SMM / PGM	IN
	J1-C	DONGLE CS	SMM	OUT
	J1-D	DONGLE SK	SMM	OUT
	J1-E	DONGLE TX	SMM / PGM	OUT
	J1-F	DONGLE ALE2P	SMM	OUT
	J1-G	RCP COMMON	RCP	OUT
	J1-H	RCP BUZZER	RCP(*)	OUT
	J1-J	RCP LED	RCP	OUT
	J1-K	RCP ON	RCP	IN
	J1-L	DONGLE GND	SMM / PGM	OUT
	J1-M	N/C		

Table 1: J1 connector pin-out

(*)This wire is not used with some versions of Remote Control Panels. For precise information, refer to Remote Control Panel technical description.

J2

Connector J2 is used to connect the external antenna through a 50 Ω coaxial cable for use as fixed ELT or the auxiliary antenna for use as survival ELT.

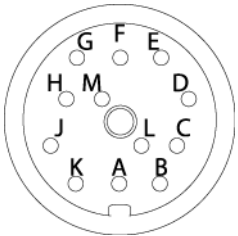
6. Technical Specifications

TYPE

- Three-frequency ELT
(121.5 / 243.0 / 406.025 MHz)
- Automatic fixed
- COSPAS-SARSAT Class II
(-20°C to +55°C).

406 MHz TRANSMISSION

- Frequency: 406.025 MHz +/- 2 kHz
- Output power: 5W (37 dBm +/- 2 dB)
- Modulation type: 16K0G1D (Biphase L encoding)
- Transmission duration:
440ms (short message) every 50 sec. compatible with long message transmission (520ms)
- Autonomy: Over 24 hours at -20°C

121,5/243 MHz TRANSMISSION

- Frequencies:
121.5 MHz +/- 6 kHz
243.0 MHz +/- 12 kHz
- Output power: 100 to 400 mW (20dBm to 26 dBm) for each frequency
- Modulation type: 3K20A3X
- Modulation rate: between 85 and 100%
- Frequency of modulation signal:
1420 Hz to 490 Hz with decreasing sweep
- Autonomy: Over 48 hours at -20°C

CONTROLS

- ARM / OFF / ON switch
- Bright red visual indicator
- BNC antenna connector
- DIN12 connector for remote control panel (RCP) and pin programming option.
- Buzzer

G-SWITCH SENSOR

Mechanical G-switch sensor at 45° compliant with EUROCAE ED62 specifications.

BATTERY

KIT BAT300, P/N : S1820516-99

3 x LiMnO₂ D type cells for transmitter power supply

Replacement every 6 years

HOUSING

Material: Molded plastic

Color: Yellow (color compounded)

Transmitter dimensions:

172 mm x 82 mm x 82 mm

Overall dimensions:

max 290 mm x 115 mm x 95 mm

Weight: typical 1235 g / max 1300 g (including battery)

Tightness: O-rings

ENVIRONMENTAL CONDITIONS

RTCA DO-160D / EUROCAE Ch1 to 25
[D1]XBA[ED62][YLMC]AWXXXXZXXXZ
WL[(A1)(A2)(A3)XX]XXA

Note: chapters 6, 8, 9 & 10 according to DO160C.

QUALIFICATIONS

ETSO-2C91a & ETSO-2C126

(EUROCAE ED62)

TSO-C91a & TSO-C126 (RTCA DO183 & DO204)

7. Activation

A. Standby mode for automatic activation

In order to be automatically activated by the crash sensor, the ELT must be in standby mode. This mode is mandatory during the flight. We recommend to switch the ELT off only when the aircraft is parked for a long period or for a maintenance operation.

- Check that the antenna is correctly connected.
- Switch to " ARM".

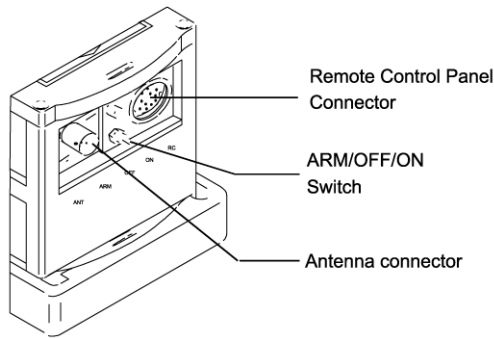

To operate the ELT with the Remote Control Panel, ensure that:

- The ELT switch is in the "ARM" position.

B. Manual activation as fixed ELT

- Check that the external antenna is correctly connected.
- Switch to " ON " (either on the ELT or on the Remote Control Panel):
 - The ELT starts with the self-test sequence.
 - 121.5 / 243 MHz transmission starts immediately after the self-test.
 - 406 MHz starts after 50 seconds (406 burst every 50 sec during 24 hours).
 - During transmission, buzzer operates and visual indicator flashes.

C. Manual activation as survival ELT

The KANNAD 406 AP-H can be used external the aircraft in survival version. A tether is used to fix the transmitter to a liferaft in case of ditching.

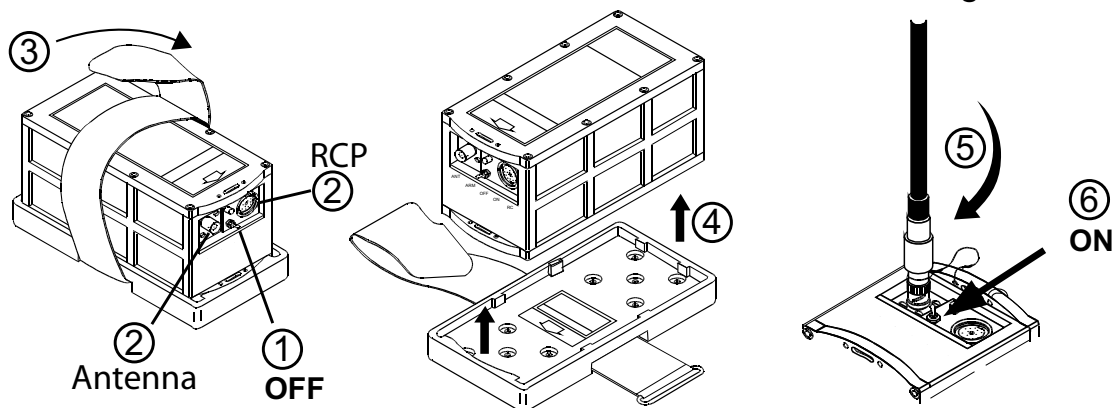

1. Switch to "OFF".
2. Disconnect the external antenna (ANT) and the Remote Control Panel (RC).
3. Unfasten the Velcro® strap.
4. Remove the transmitter and the auxiliary antenna from the bracket.
5. Connect the auxiliary antenna (ANT).
6. Switch to "ON":
 - **Important: Put the antenna in a vertical position.**
 - The ELT starts with the self-test sequence.
 - 121.5 / 243 MHz transmission starts immediately after the self-test.
 - 406 MHz transmission starts after 50 seconds.
 - During transmission, buzzer operates and visual indicator flashes periodically.

8. Reset

It is possible to stop the ELT in case of unintentional activation.

Regulations state that no transmission must be interrupted unless every means are used to contact and inform the Air Traffic Controller of this action.

Important notice: As 406 MHz transmission is effective 50 seconds after the ELT activation, if it is reset within this delay, no further radio contact will be necessary.

A. Manual reset

- Switch to " OFF " .

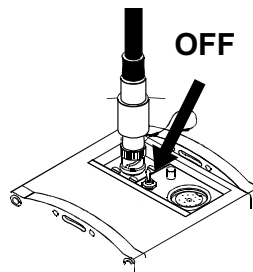

B. Reset with Remote Control Panel

- The switch has to be in the "ARM" position on the ELT.
- Switch to " RESET & TEST" on the remote control panel.

9. Self-Test

[Refer to 1. Self-test, page 301](#)

PAGE INTENTIONALLY LEFT BLANK

INSTALLATION / REMOVAL**1. Registration and Programming**

The ELT must be registered prior to installation on board.

The registration card available from the local registration authority must be completed and returned to this authority.

The "Programming Datasheet" (DIM0300) must be completed and returned to your distributor.

Any change of ownership shall also be declared and registered with the local registration authority and with the distributor.

The KANNAD 406 AP-H is fully compatible with the four programming protocols defined by the COSPAS-SARSAT C/S G005 document:

- Serialised Number.
- Aircraft 24 bit Address (the same as MODE S ATC or TCAS).
- Aircraft Operator Designator + serialised number up to 4096.
- Aircraft Nationality and Registration marking (Tail Number). This identification consists of up to 7 alphanumeric characters.

Programming of the ELT can be carried out either:

- by KANNAD or the distributor (order must include programming details).
- in the shop with a programming and test equipment (PC interface and DOS or Windows[®] software).
- on board the aircraft with a programming equipment or programming dongle.

This operation takes less than 2 minutes and does not need any hardware operation. The identification is simply downloaded in the ELT when connected to the KANNAD programming equipment via the DIN 12 connector.

A. Pin programming option

The KANNAD 406 AP-H offers pin-programming capabilities to facilitate maintenance operations especially in case of removals and/or replacement.

A special DIN 12 connector with a Serial Memory Module (called "Programming Dongle") is connected to the ELT when installed on board. This Programming Dongle contains the identification information of the aircraft and remains on board the aircraft. When an unprogrammed ELT is installed and connected to this Programming Dongle and the "ELT" is switched to "ARM", it automatically updates its own memory with the identification data contained in the

Programming Dongle memory.

When the ELT is removed from the aircraft, it keeps its identification data.

For maintenance purposes, it is possible to delete the identification information of the ELT by connecting a "Maintenance Dongle" to the ELT. Any accidental transmission with this "maintenance dongle" will not involve SAR operation as the identification code transmitted is recognised by COSPAS-SARSAT as "not on board".

When a maintenance dongle is connected:

- Country code is **227** (France).
- Protocol is **Test**.
- Identification number is **SI + 5 digits** (the last 5 digits of CSN number) or **K + 6 digits** (the 6 digits of the CSN number).

If the pin programming option is selected by the operator, the following equipment are required:

- a "Programming Dongle" on each aircraft;
- a "Maintenance Dongle" on each ELT spare.



Figure 201: Maintenance Dongle

2. ELT Installation

A. Installation recommendations

"The ELT shall not be installed within 60cm (2 ft) of a compass or flux gate.

The distance between ELT and antenna shall be determined so that, according to the coaxial cable chosen, the cable loss should be ≤ 1 dB at 400 MHz.

The ELT front panel should be easily accessible to connect the outside antenna and the remote control panel device and to check the ELT good operation (controls and lights).

(1) FAA Recommendations

Installation must be made by qualified personnel in accordance with FAA regulations. Duplicating a previous installation may not be acceptable.

Refer to:

FAA - Advisory Circular 43.13-2A (Acceptable Methods, Techniques, and Practices - Aircraft Alterations), specifically, Chapters 1, 2, 11 and 13.

(2) TSO C126a Section 5 b. Application Data Requirements

"The conditions and tests for TSO approval of this article are minimum performance standards. Those installing this article, on or in a specific type or class of aircraft, must determine that the aircraft installation conditions are within the TSO standards. TSO articles must have separate approval for installation in an aircraft. The article may be installed only according to 14 CFR part 43 of the applicable airworthiness requirements".

(3) RTCA DO-182 Recommendations

"All ELT system components which must survive to a crash intact,...should be attached to the airframe in such a manner that the attachment system can support a 100g load... in the plus and minus directions of the three principal axes of the aircraft."

(4) RTCA DO-204a Requirements

"The ELT unit shall be mounted to primary aircraft load-carrying structures such as trusses, bulkheads, longerons, spars or floor beams (not aircraft skin) or a structure that meets the requirements of the following test. The mounts shall have a maximum static local deflection no greater than 2.5 mm when a force of 450 Newtons (100 lbf) is applied to the mount in the most flexible direction. Deflection measurements shall be made with reference to another part of the airframe not less than 0.3 m or more than 1.0 m from the mounting location. Typical approaches for adding shelf and rail platform mounting provisions to aircraft structure as shown an FAA Advisory circular 43.13-2(), Chapter 2."

B. Bracket installation

- Determine the location of the ELT on board according to FAR/RTCA recommendations.
- The G-Switch axis shall be directed to sense the primary crash pulse along the longitudinal axis of the aircraft. Reference to the G-Switch is given by the arrow "Sens du Déplacement / Flight direction".

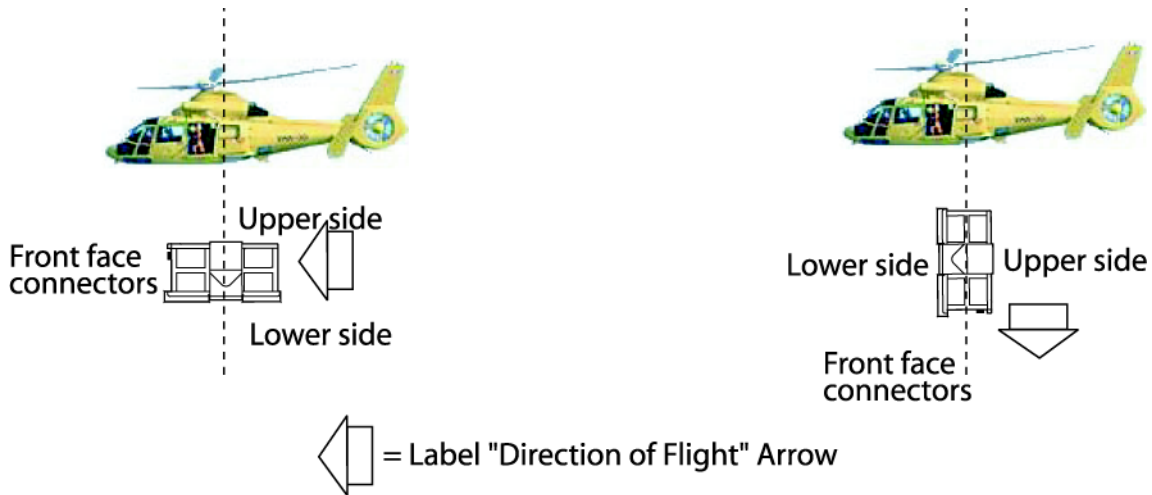

Figure 202: KANNAD 406 AP-H, installation

IMPORTANT: The KANNAD 406 AP-H is designed to be installed on board helicopters only.

The "Direction of Flight " arrow shall point towards the front or the bottom of the helicopter (and not pointing 45° downwards) with maximum tolerance of 15°:

- If the KANNAD 406 AP-H is installed with the "Direction of Flight " arrow pointing towards the front of the helicopter, the ELT shall be mounted with the upper side pointing towards the top of the helicopter.
- If the KANNAD 406 AP-H is installed with the "Direction of Flight " arrow pointing towards the bottom of the helicopter, the ELT shall be installed with the lower side pointing towards the front of the helicopter.

Drill 4 holes Ø 6 mm in the aircraft structure according to "Drilling mask". Holes 4,5,6,7 shall be preferred.

If the aircraft structure is not solid enough to withstand a 500 kg traction on the bracket, a reinforcement plate (not supplied) should be installed as shown [Figure 203: Bracket installation](#).

Fix the bracket with the 4 screws, 8 washers and 4 nylostop nuts supplied.

IMPORTANT: tighten to a torque between 4 and 5 Newton x meter.

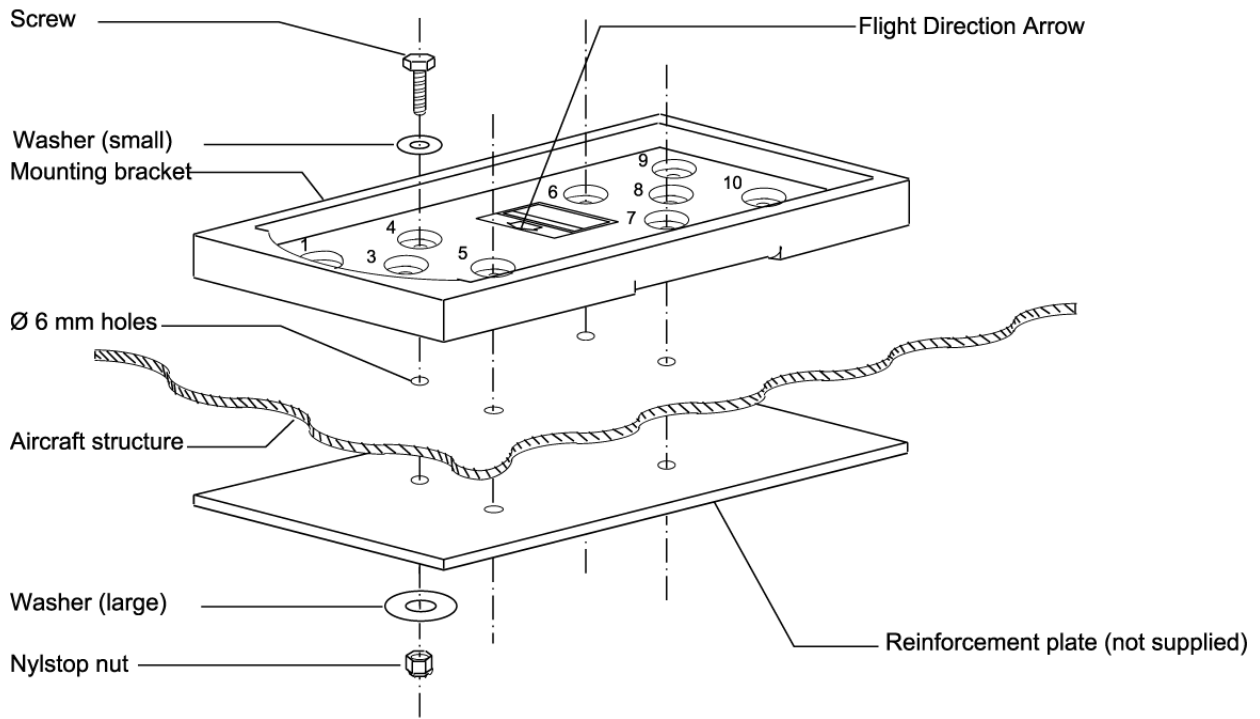

Figure 203: Bracket installation

C. Transmitter and auxiliary antenna installation

- Verify that the ELT identification label matches the aircraft tail number.
- Mount the transmitter on the bracket.
- Slide the self-stripping strap through the buckle and fasten it tightly.

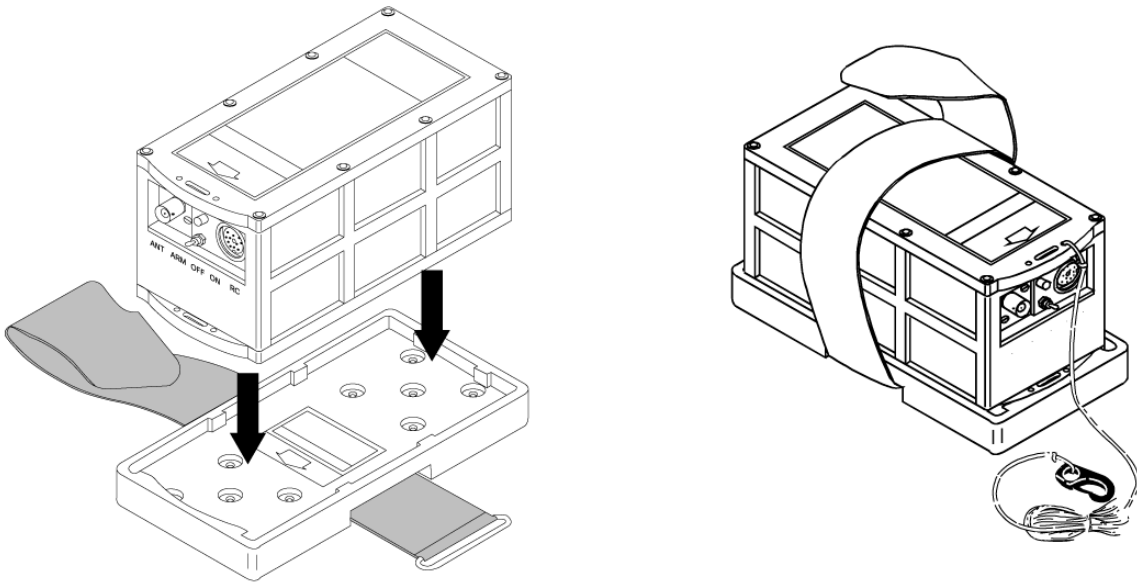
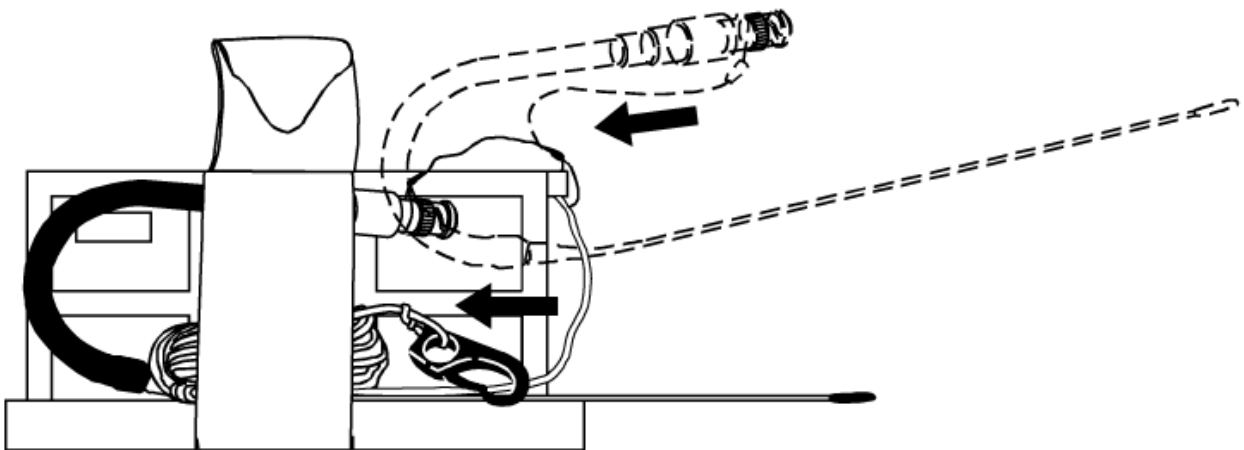

Figure 204: Installing the transmitter on the bracket

- Fold the antenna and slide it under the Velcro® strap.



3. Antenna Installation

The external antenna can be either of whip, rod or blade type according to aircraft speed. Use only approved antennas.

Connection to the ELT will be carried out with a 50 Ohm coaxial cable (RG58 for example) ended with two male BNC connectors.

A. Antenna Installation Recommendations

(1) FAA Recommendations

Installation must be made by qualified personnel in accordance with FAA regulations. Duplicating a previous installation may not be acceptable. Methods for installing antenna are outlined in AC43.13-12, refer to:

FAA - Advisory Circular 43.13-2A (Acceptable Methods, Techniques, and Practices - Aircraft Alterations), specifically, Chapters 1, 3, 11 and 13.

(2) RTCA DO-204 Requirements for ELT location

"ELT antennas should be located away from other antennas to avoid disruption of antenna radiation patterns."

"Idealistically, for the 121.5 MHz ELT antenna, 2.5 meter separation is sufficient separation from VHF communications and navigation receiving antennas to minimize unwanted interferences."

"ELT antennas should be vertically polarized when the aircraft is in the normal flight attitude."

"ELT antenna mounting surface should be able to withstand a static load equal to 100 times the antenna weight applied at the antenna mounting base in all directions."

"The antenna should be mounted as close to the respective ELT as applicable. The proximity of the ELT antenna to any vertically-polarized communications antenna shall be such as to minimize radio frequency interference and radiation pattern distortion of either antenna. Coaxial cable connecting the ELT antenna installation should not cross the aircraft production breaks and should have vibrations proof RF connectors on each end. The coaxial connecting the ELT transmitter to the external Antenna should be secured to the aircraft structure and when the coaxial cable is installed and the connectors are mated, each end should be have some slack."

B. Antenna installation procedure

The antenna must be mounted on the top of the aircraft to assure maximum visibility of satellites. The upper aft portion of the fuselage should be preferred. It should be mounted away from projections such as a propeller, tail surfaces, or the shadow of large antennas. It is the responsibility of the installation agency to determine the appropriate and adequate antenna installation.

Locate a position on the fuselage according to [Refer to \(2\) RTCA DO-204 Requirements for ELT location, page 207](#):

A double plate may be necessary for the antenna to meet rigidity specifications in Section [\(2\) RTCA DO-204 Requirements for ELT location page 207](#).

A 9 Kilogram force (20 pound force) applied in all direction should not cause an appreciable distortion in the aircraft skin.

Each of the approved antennas requires a ground plane. On fabric-covered aircraft or aircraft with other types on nonmetallic skins, a ground plane must be added. This can be accomplished by providing a number of metal foil strips in a radial position from the antenna base and secured under the fabric or wood skin of the aircraft. The length of each foil radial should be at least equal to the antenna length and width at least 1 inch due to the diameter of the antenna. The ground plane must be connected to the shield of the antenna connector.

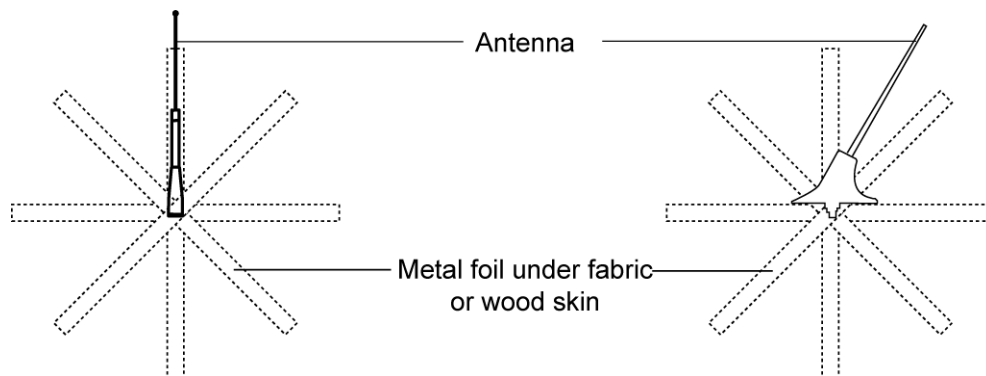

Figure 205: Antenna ground plane for non metallic aircraft

According to the antenna to be installed, use the appropriate outline drawings and drilling masks to determine the hole pattern and drill size ([Refer to SCHEMATICS & DIAGRAMS, page 501](#)).

Fabricate a 50 Ohms coaxial cable long enough to reach between the ELT installation location and the antenna location.

IMPORTANT: The length of the coaxial cable should not exceed 2.7 meters (9 ft) for a standard RG58 or equivalent coaxial cable. If the cable length exceeds 2.7 meters, a low loss cable of attenuation less than 1 dB@400 MHz must be used (See Important notice, [D. External antenna page 4](#)).

Fit both ends of coaxial cable with a waterproof Male BNC connector (not supplied), reference RADIALL R141007 or equivalent.

Connect one Male BNC connector to the antenna Female BNC socket.

4. RCP Installation (if any)

The Remote Control Panel shall be readily accessible from the pilot's normal seated position.

Refer to the manual provided with your RCP and to § 3. [Wiring page 503](#).

5. ELT connection

- Connect the outside antenna to J2 BNC connector ([Refer to Figure 206: Installation, controls and connectors](#)) as shown [Figure 2: ELT system description page 3](#).
- Connect the Remote Control Panel (or CS144) to J1 DIN12 connector ([Refer to Figure 206: Installation, controls and connectors](#)) as shown [Figure 2: ELT system description page 3](#).
- Set the 3-position switch ([Refer to Figure 206: Installation, controls and connectors](#)) to ARM.

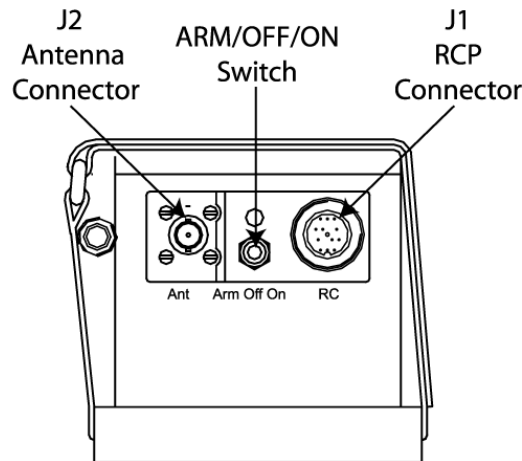

Figure 206: Installation, controls and connectors

- Perform the first power up procedure ([Refer to 6. First power up, page 209](#)).

6. First power up

Perform the following tests:

1. ELT operational tests:
 - connect RCP to J1 and outside antenna to J2;
 - switch the ELT from OFF to ARM;
 - check that the Self-Test result is OK (one long flash).
2. RCP operational tests:

[Refer to 3. RCP operational tests, page 303](#).
3. 406 & 121.5 MHz transmission tests (optional):

[Refer to 4. 406 and 121.5 MHz transmission test, page 304](#).

At the end of the first power up procedure, switch the ELT to ARM.

The ELT is now in stand by mode and ready to be activated either automatically by G-Switch sensor if a crash occurs or manually by RCP (if any).

Note : switching to ON directly on the ELT front panel will also activate the ELT.

7. Removal

- Switch the ELT to OFF (Refer to Figure 206: Installation, controls and connectors).
- Disconnect the Remote Control Panel (or CS144) from the DIN12 connector (Refer to Figure 206: Installation, controls and connectors).
- Disconnect the outside antenna from the BNC connector (Refer to Figure 206: Installation, controls and connectors).
- Unfasten the self-stripping strap.
- Remove the auxiliary antenna.
- Remove the transmitter from the bracket.

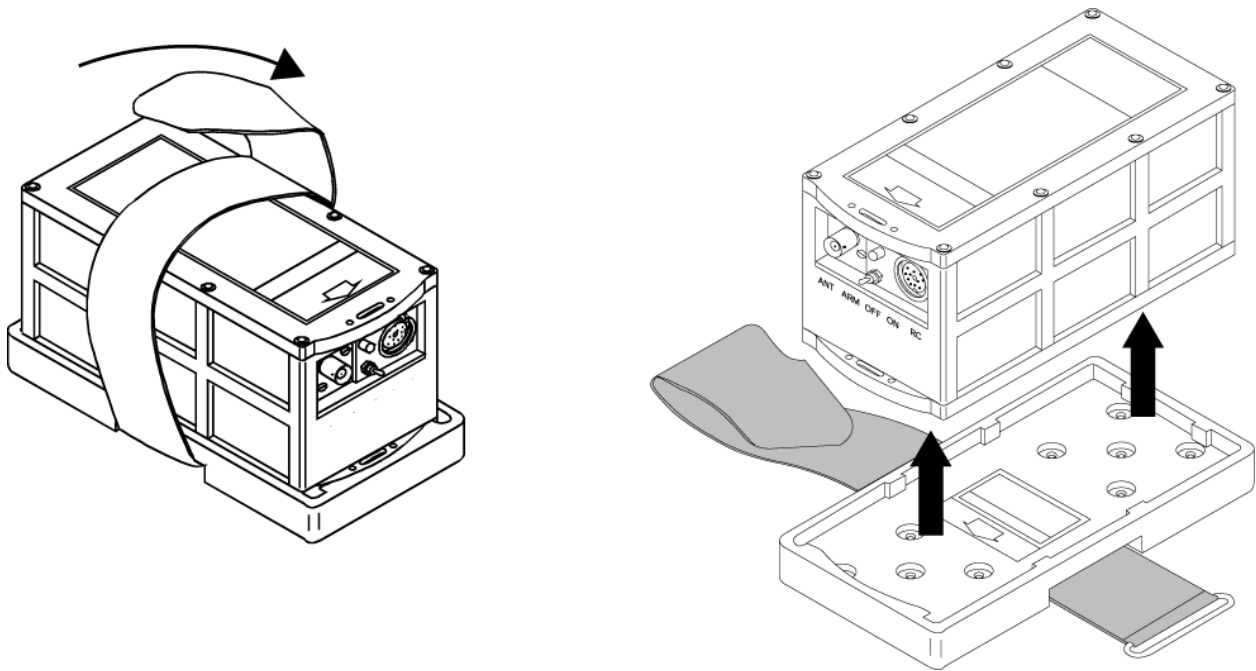

Figure 207: Removing the transmitter

CHECK

1. Self-test

A. Periodicity

It is recommended by the manufacturer to test the ELT to detect any possible failure.

It is recommended to perform a self-test once a month by pilot or maintenance personnel from the cockpit (Remote Control Panel) but it **should not be done more than once a week**.

However, each self-test consumes energy from the battery. Should self-tests be carried out more often than the maximum allowed, the battery life-time might be shorter than specified.

Do not perform Self-test without the antenna connected.

B. Self-test procedure

- Check that the antenna is correctly connected.
- Switch from position "OFF" to position "ARM" or press "RESET & TEST" on the Remote Control Panel (ensure that the ELT switch is in the "ARM" position).
 - The buzzer operates during the whole Self-test procedure.
 - After a few seconds, the test result is displayed with the visual indicator as follows:
 - One long flash indicates that the system is operational and that no error conditions were found.
 - A series of short flashes^(see Remark below) indicates the test has failed.

***If self-test fails, contact the distributor as soon as possible.
Unless a waiver is granted, flight should be cancelled.***

Remark: The number of flashes gives an indication of the faulty parameter detected during the self-test.

3+1	LOW BATTERY VOLTAGE
3+2	LOW RF POWER
3+3	FAULTY VCO LOCKING (FAULTY FREQUENCY)
3+4	NO IDENTIFICATION PROGRAMMED

2. ELT operational tests

A. Installation without programming dongle

- connect RCP to J1 and outside antenna to J2;
- switch the ELT from OFF to ARM;
- check that the Self-Test result is OK (one long flash).

B. Installation with Programming Dongle

- connect the outside antenna to J2;
- switch the ELT from OFF to ARM;
- check that the Self-Test fails (3+4 flashes);
- if not, connect a maintenance dongle to J1:
 - Switch the ELT from OFF to ARM;
 - Check that the Self-Test fails (3+4 flashes);
 - Remove the maintenance dongle from J1.
- connect the "Programming Dongle" to J1;
- switch the ELT from OFF to ARM:
the buzzer operates during the whole self-test procedure, after a few seconds the LED displays the result.
- check that the Self-Test result is OK (one long flash).

3. RCP operational tests

Check correct operation of RCP LED and external buzzer by switching ELT and RCP as described in the sequential procedure hereunder (with ELT switch in the "ARM" position).

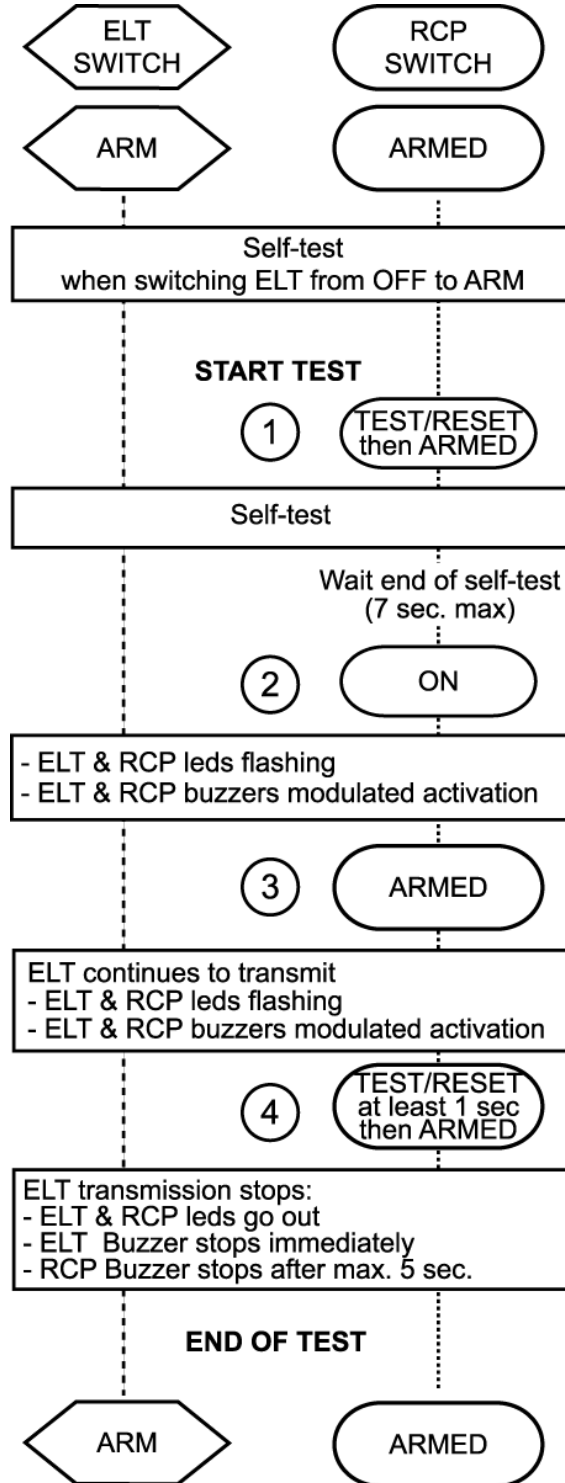

Figure 301: RCP LED and buzzer operation

IMPORTANT: (2) before switching the RCP to ON, wait for the end of the self-test.

4. 406 and 121.5 MHz transmission test

A. ELT-Antenna link

ELT -Antenna link can be checked by testing VSWR.

KANNAD recommends the use of SWR3000 VSWR meter manufactured by PROCOM.

Refer to SWR3000 manufacturer's user manual for a VSWR measurement.

B. 406 MHz

This test must be carried out with a COSPAS-SARSAT decoder.

- Perform self-test (Press RESET and TEST on the RCP or switch ELT from OFF to ARM).
- Check with the COSPAS-SARSAT decoder that, except for the 5th and the 6th digits, the decoded message is identical to the programmed message.

NOTE: The message transmitted during self-test sequence always begins with FF FE D0 whereas a programmed message begins with FF FE 2F.

Example of message programmed in ELT:

FF FE 2F 53 C3 24 97 38 0B A6 0F D0 F5 20

Example of same message decoded by SARTECH ARG5410:

FF FE D0 53 C3 24 97 38 0B A6 0F D0 F5 20

C. 121.5 MHz

IMPORTANT: this test must only be carried out between H and H+5 minutes. Do not exceed 30 seconds of transmission.

This test must be carried out with a VHF receiver.

- Tune VHF receiver to 121.5 MHz;
- Start transmission:
 - either on ELT: ON position;
 - or on the RCP: ON position (the ELT shall be in the ARM position);
- Listen to the 121.5 MHz "sweep tone";
- Stop transmission:
 - either on ELT: OFF or ARM position;
 - or on the Remote Control Panel: press TEST and RESET (the ELT shall be in the ARM position).

TROUBLESHOOTING

1. General

Procedure for fault isolation on board uses the visual indicator of the ELT's front panel. This visual indicator is activated by a self-test capability within the ELT.

2. Faults on Self-test

A. Visual indicator

When the self-test is carried out, the number of flashes gives an indication of the faulty parameter detected during the self-test.

(1) 3+1 flashes

- Low battery voltage:
Check battery, refer to CMM 25-63-01 for repair^(see note 1 below).

(2) 3+2 flashes

- Low RF power:
Check 406 MHz power, refer to CMM 25-63-01 for repair^(see note 1 below).

(3) 3+3 flashes

- Faulty VCO locking (faulty frequency):
Check 406 MHz frequency, refer to CMM 25-63-01 for repair^(see note 1 below).

(4) 3+4 flashes

- No identification programmed
Check programming^(see note 2 below).
- NOTE: (1) Only PART/FAR 145 certified stations accredited by KANNAD can perform these repairs.
(2) Only accredited programming stations can perform programming.

3. Other faults detected

A. Buzzer

(1) Buzzer does not operate

- Refer to CMM 25-63-01 for repair^(see note 1 above).

(2) Buzzer operates permanently when ELT in ARM mode

- Refer to CMM 25-63-01 for repair^(see note 1 above).

PAGE INTENTIONALLY LEFT BLANK

SCHEMATICS & DIAGRAMS

1. Outline Dimensions

Note: all dimensions are in millimeters
(inches in bracket)

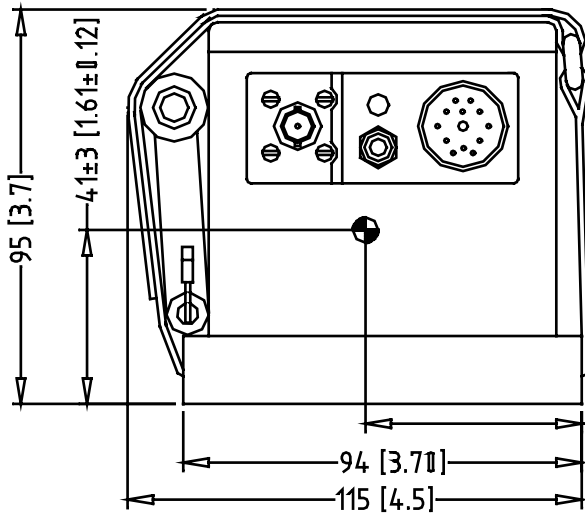
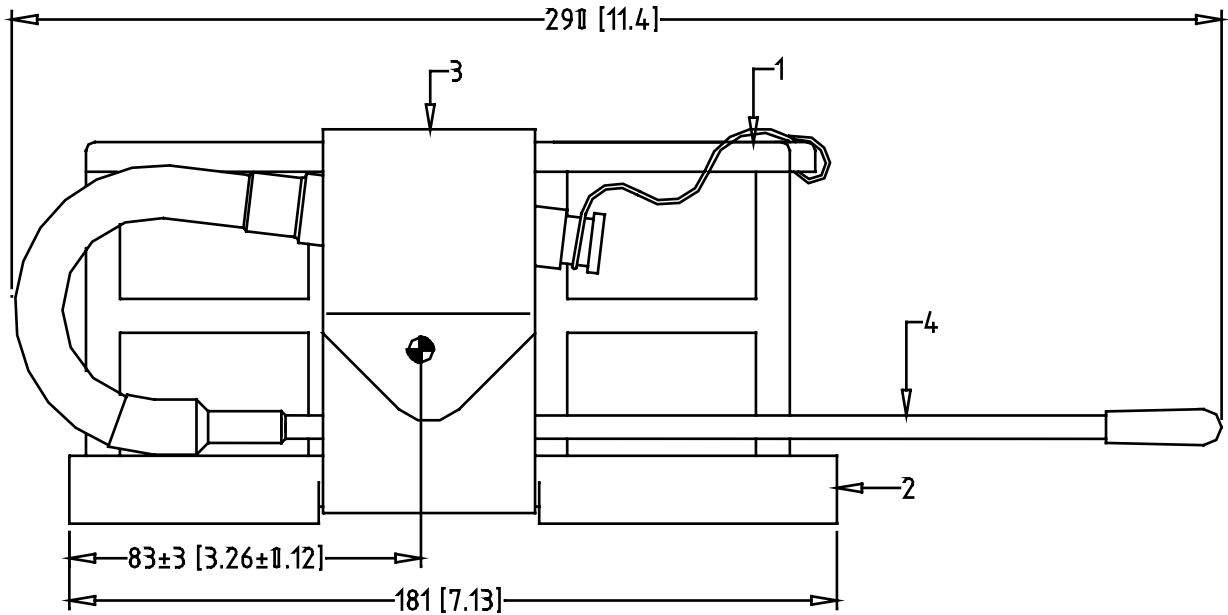

ITEMLIST		
IDENT	DESCRIPTION	PART NUMBER
1	ELT MODEL KANNAD 406 AP H	S1821 512 14
2	MOUNTING BRACKET	S1821 511 11
* 3	VELCRO STRAP	S1821 512 11
** 4	AUXILIARY ANTENNA	HAF 11118

* PART OF S18 21 511 11

** PART OF S18 21 512 14

WEIGHT:

TYPICAL: 1235g MAX.:1311g

● CENTER OF GRAVITY

3. Wiring

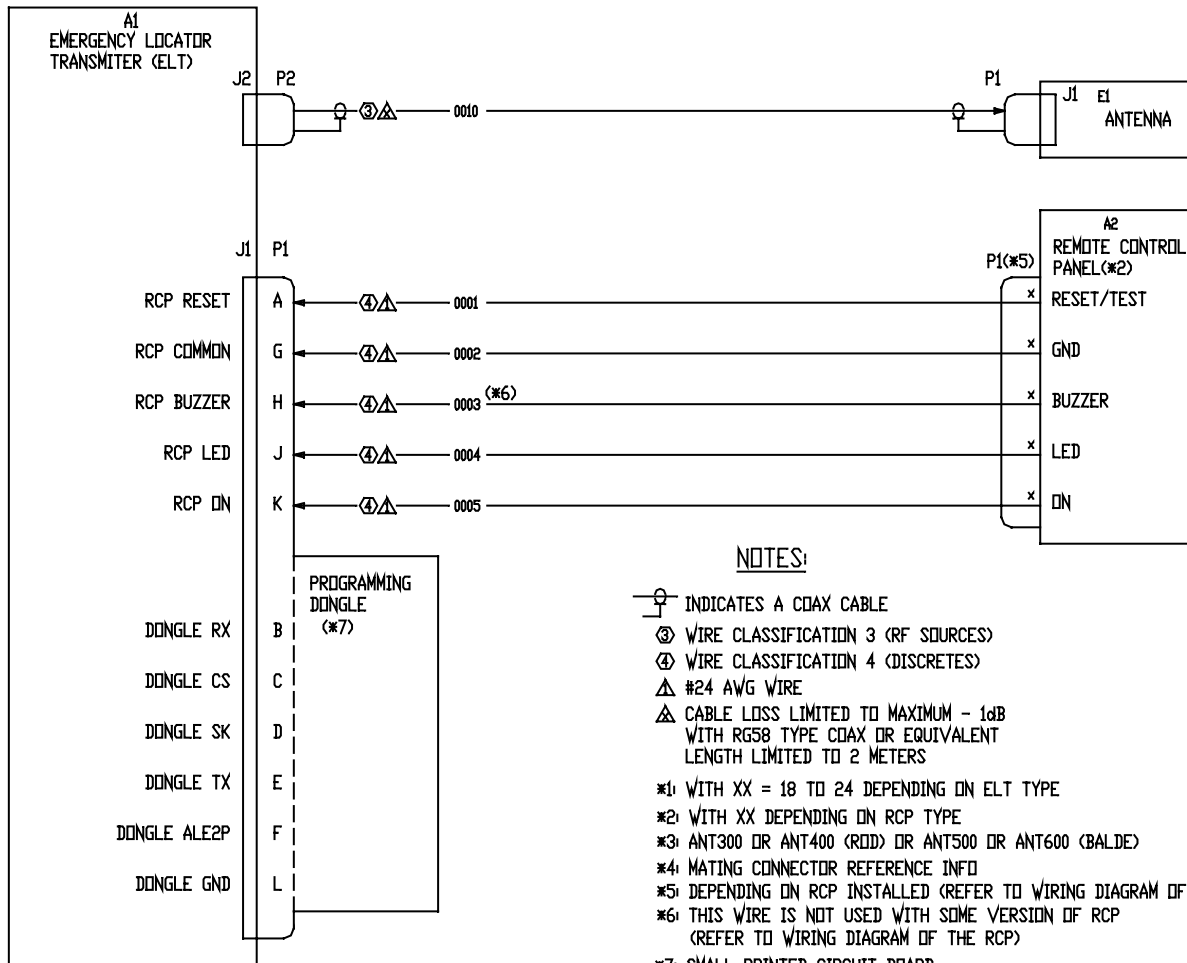

NOTES:

- ⊖ INDICATES A COAX CABLE
- ③ WIRE CLASSIFICATION 3 (RF SOURCES)
- ④ WIRE CLASSIFICATION 4 (DISCRETES)
- △ #24 AWG WIRE
- △ CABLE LOSS LIMITED TO MAXIMUM - 1dB WITH RG58 TYPE COAX OR EQUIVALENT LENGTH LIMITED TO 2 METERS
- *1: WITH XX = 18 TO 24 DEPENDING ON ELT TYPE
- *2: WITH XX DEPENDING ON RCP TYPE
- *3: ANT300 OR ANT400 (RDD) OR ANT500 OR ANT600 (BALDE)
- *4: MATING CONNECTOR REFERENCE INFO
- *5: DEPENDING ON RCP INSTALLED (REFER TO WIRING DIAGRAM OF THE RCP)
- *6: THIS WIRE IS NOT USED WITH SOME VERSION OF RCP (REFER TO WIRING DIAGRAM OF THE RCP)
- *7: SMALL PRINTED CIRCUIT BOARD (INSTALLED INSIDE DIN 12 CONNECTOR PLUG AND SOLDERED TO PINS B, C, D, E, F, L)

4. ANT AV200, outline dimensions and drilling mask

Note: all dimensions are in millimeters
(inches in brackets)

Weight: 85 g (0.19 lbs)

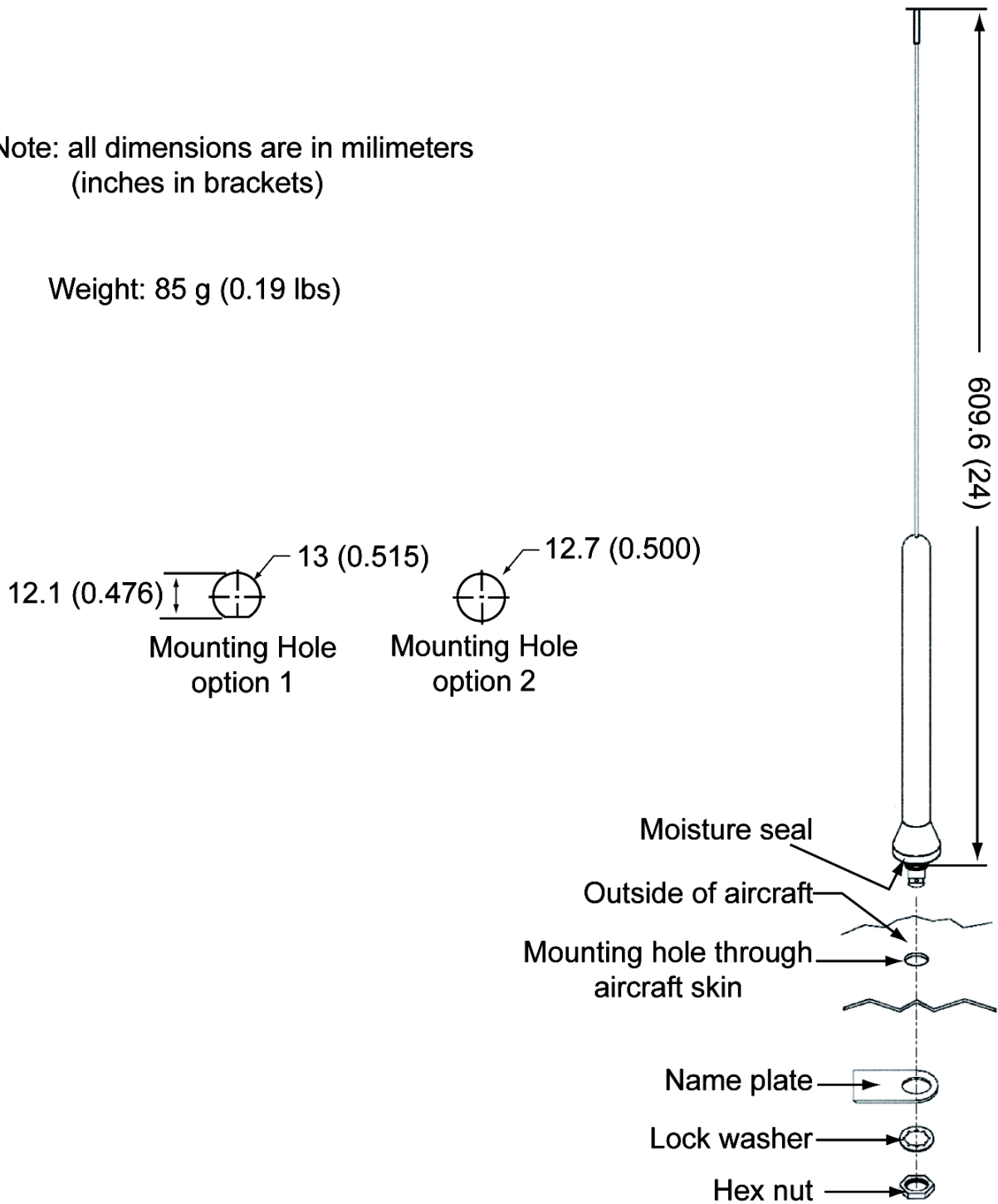

5. ANT AV300, outline dimensions and drilling mask

Note: all dimensions are in millimeters (inches in brackets)

Weight: 255 g. (0.56)

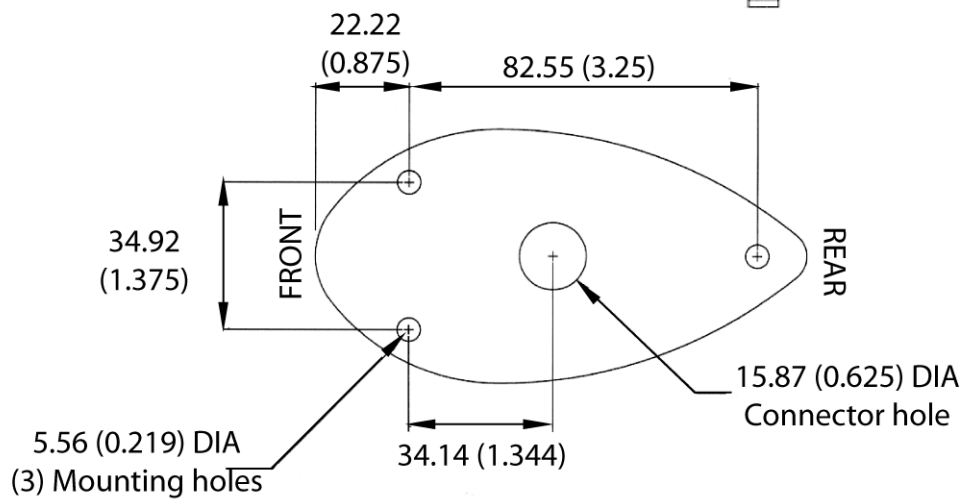
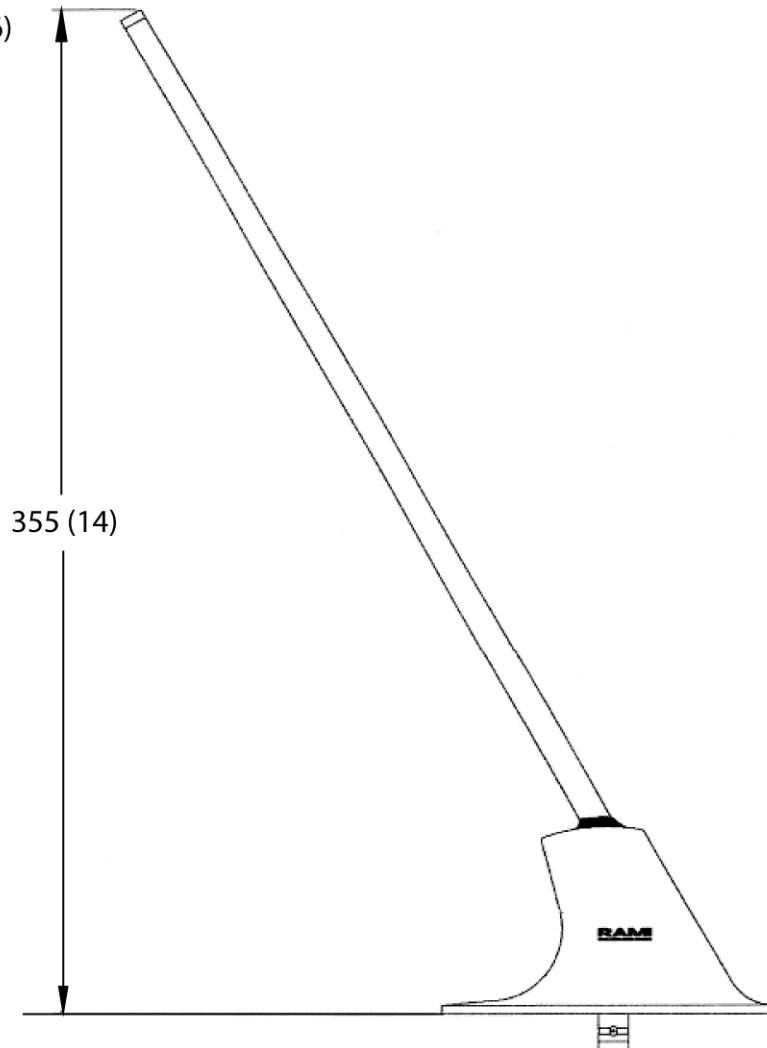

6. ANT300, outline dimensions and drilling mask

Note: all dimensions are in millimeters
(inches in brackets)

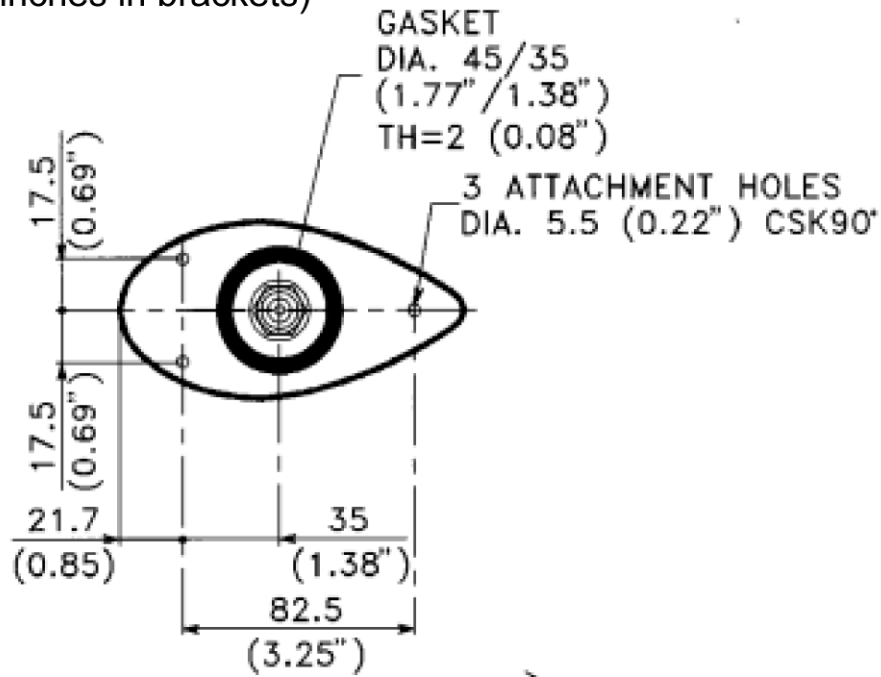

Weight: 150 g (0.33 lbs)

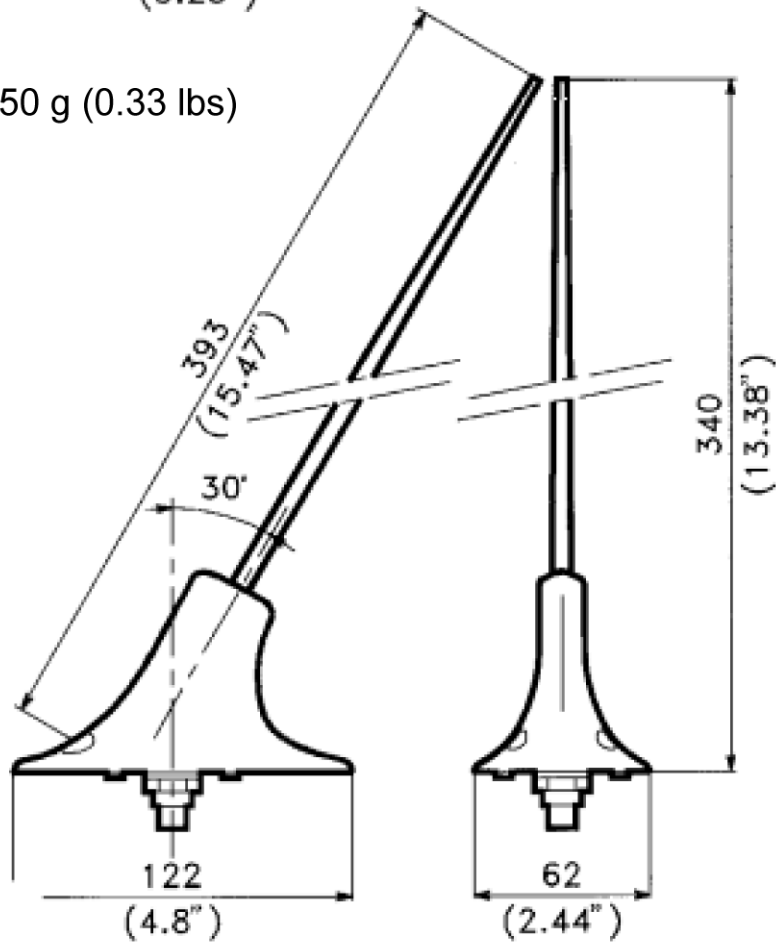

7. ANT 410, outline dimensions and drilling mask

Note: all dimensions are in millimeters (inches in brackets)

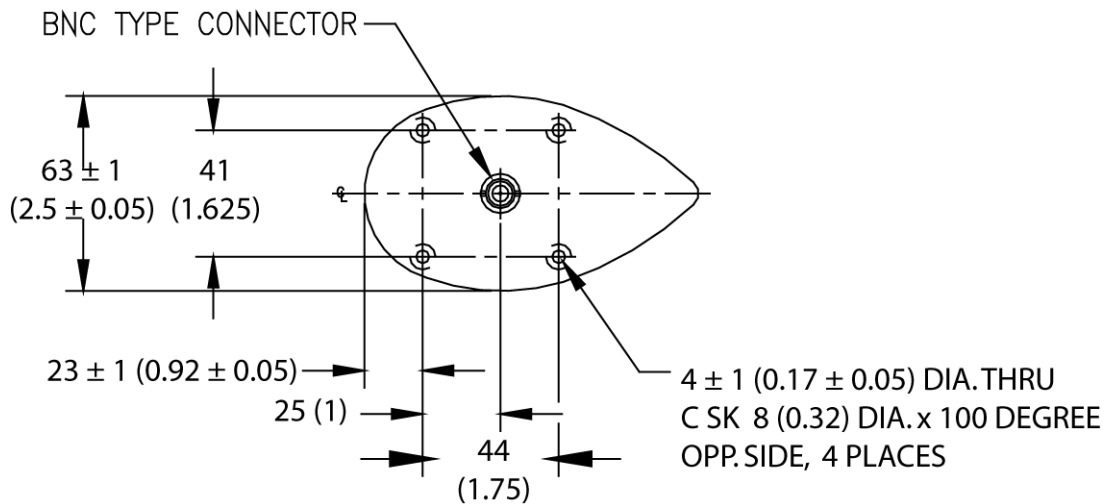
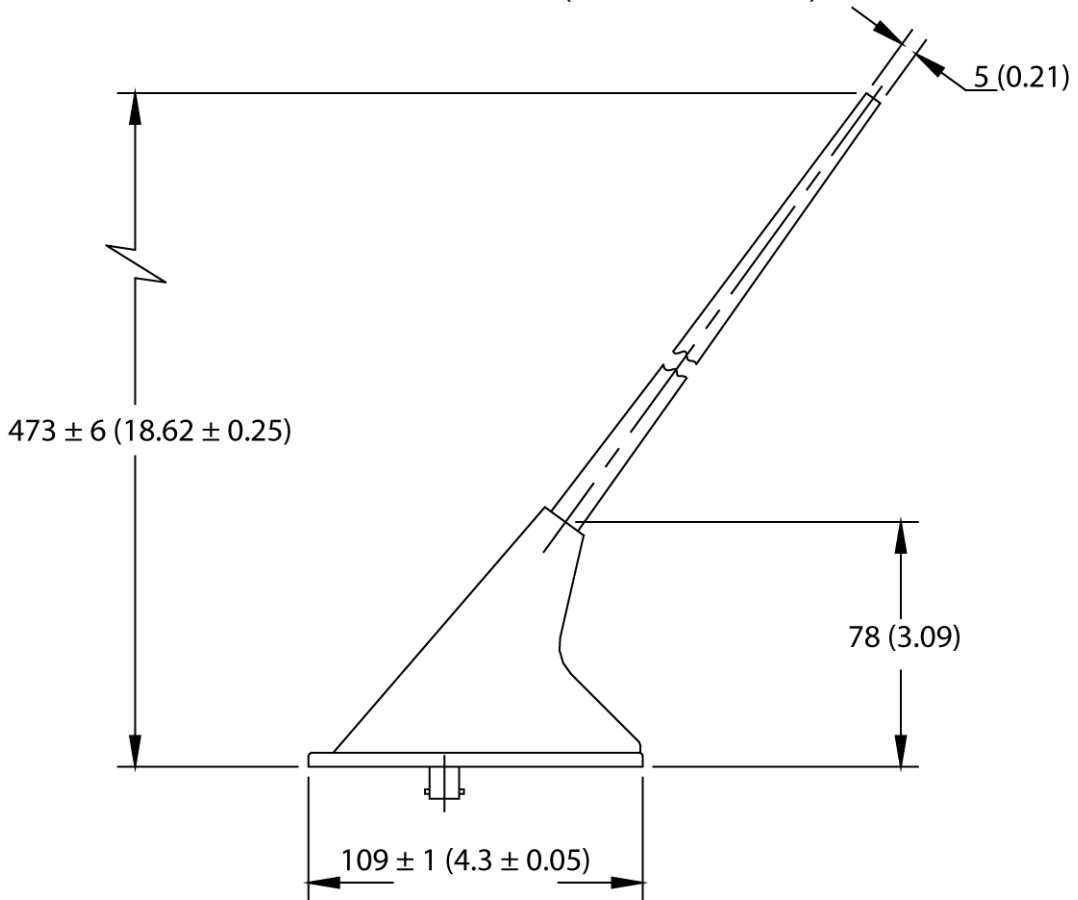

PAGE INTENTIONALLY LEFT BLANK

SERVICING

1. Maintenance Schedule

Periodic inspection and battery replacement can only be carried out by PART 145 / FAR 145 avionic workshops (or equivalent agreement according to local regulations).

A. Periodic inspection

Note: (if required by the relevant Civil Aviation Authority).

Some Civil Aviation Authorities may require the ELT is tested periodically. In this case, KANNAD recommends to check the following parameters:

- Battery voltage.
- 121.5 MHz / 243.0 MHz / 406.025 MHz transmission power.
- 121.5 MHz / 243.0 MHz / 406.025 MHz frequency.
- VCO lock.
- 121.5 MHz AM decoding (sweep monitoring with VHF receiver).
- Number of 406 MHz transmissions (optional, programming kit required).
- Number of self-tests carried out (optional, programming kit required).
- Programmed data (optional, programming kit required).

NOTE: This functioning check can be carried out without opening the ELT.

B. Every 6 years

Testing of the various elements of the ELT is mandatory every 6 years together with the battery replacement.

- Visual control of the housing and accessories
Refer to CMM 25-63-01.
- O-ring, battery and desiccant capsule replacement
Refer to CMM 25-63-01.
- Beacon Tightness
CMM 25-63-01.
- "Testing and Fault Isolation" procedure as described in CMM 25-63-01.

C. Battery replacement

Battery replacement is mandatory:

- after more than 1 hour of real transmission (cumulated duration);
- before or on the battery expiration date.

***Only original battery pack included in battery kit
(KIT BAT 300, P/N S1820516-99)
supplied by KANNAD can be installed.***

***KANNAD refuse all responsibility and invalidate
all warranty should other packs be installed.***

Battery available from any KANNAD distributor or dealer.

KANNAD

Z.I. des Cinq Chemins BP23

56520 GUIDEL - FRANCE

Telephone: +33 (0)2 97 02 49 49 Fax: +33 (0)2 97 65 00 20

Web: <http://www.kannad.com> - E-mail: contact.aviation@kannad.com

Support: support.sar@kannad.com Tel.: +33 (0)2 97 02 49 00

List of distributor available on our Web site:

<http://www.kannad.com>

Distributed by

Manufactured by

The logo for KANNAD features the word 'KANNAD' in a bold, sans-serif font. The letters 'KAN' are dark blue, and the letters 'NAD' are yellow. The letters are closely spaced and have a slight shadow effect.

KANNAD

Z.I. des Cinq Chemins BP 23

56520 GUIDEL - FRANCE

Tél. / Phone : +33 (0) 2 97 02 49 49

Fax : +33 (0) 2 97 65 00 20

www.kannad.com

DOC06330D

Ref: 0143020D