

Table of Contents:

Safety and Service	2
Operational Safety	2
Location	2
Ambient Temperature	3
Electromagnetic Compliance	3
Service	4
Cleaning	4
Disposal	4
Package Contents	4
Connections and Controls	5
Front of the active Subwoofer	5
Rear of the active Subwoofer	6
Setting Up	8
Positioning the 5.1 System	8
Connecting the 5.1 System	9
1. Connecting the Subwoofer	9
2. Connecting the Subwoofer to a Sound Source	10
3. Connecting the Power Adapter	11
Operation and Handling	12
Service	13
Support in the Event of a Malfunction	13
Do You Require Additional Support?	13
Specifications	14

Safety and Service

Please read this chapter carefully and follow all instructions. In doing so you will ensure the reliable operation of and a long life for your 5.1 speaker system. Keep the manual close to your 5.1 system. Store the manual safely so that you can pass it on to the new owner should you sell your speakers.

Operational Safety

- **Never open the housing** of the 5.1 system, the speakers or the power adapter! There is life threatening danger by electric shock if the housing of the power adapter is opened. There are no serviceable parts inside.
- **Children** should **never** play **unattended** with electrical equipment. Children cannot always recognise potential hazards properly.
- This 5.1 system is **not** designed for operation in a **heavy industrial environment**.

Location

Follow these instructions to connect your 5.1 system properly:

- A **power supply socket** must be close to the device and **easily accessible**. Run cables in a way that no one can step or **trip** over them.
- The power supply to your device is interrupted **only** when the **power plug is removed from the power socket**. If you switch off the device using the power switch, then the power feed is **not interrupted**. Always hold the plug firmly when removing it. To avoid product damage never pull by the power cord.
- Operate the power adapter only on grounded power outlets with **AC 230V ~ 50 Hz**. When in doubt about the power type at your location, contact the related power utility company.
- Do not cover the power supply unit, in order to avoid damage through unacceptable warming.
- Stop using the power supply unit if the housing or the feed line to the device is damaged. Replace it with a power supply unit of the same type.
- In the first hours of operation, new devices may emit a typical, unavoidable but completely harmless smell, which will decline increasingly in the course of time. We recommend that you ventilate the room regularly, in order to counteract the formation of the smell. During the development of this product, we have made sure that, it is clearly below the applicable limits.
- To avoid damage never place any objects on the power cord.
- Do not expose your 5.1 system, the loudspeakers or any connected devices to humidity. Avoid dust, heat and exposure to direct sunlight to prevent operating failure.

- Place and operate all the components on a stable and flat surface, free of vibrations, to prevent the loudspeakers from falling.
- Only use in a suitable ambient temperature.

Ambient Temperature

- The 5.1 system can be operated in an ambient temperature range between 0° C and 40° C and a relative humidity between 20% and 80% (non-condensing). When switched off the 5.1 system can be stored between -20° C and 70° C and at a relative humidity between 20% and 90% (non-condensing).

Electromagnetic Compliance

- The **guidelines** for electromagnetic compliance (EMC) **must be obeyed** when operating the speakers.
- Only use the supplied power cord.
- Keep a **distance** of at least three feet from **sources of** high frequency or magnetic **interference** (TV sets, other loudspeakers, mobile phones, etc.) to avoid interference, malfunction and data loss.

Service

Please contact our Customer Care should you experience technical problems with your 5.1 system. Repair is **solely** reserved for our **authorised service partners**.

Remove the power plug and contact our service organisation, if...

- liquid has penetrated to the inside of the device.
- the 5.1 system does not operate properly.
- the device has dropped, fallen or the housing is damaged.

Cleaning

- Clean the 5.1 system with a damp cloth. Do not use solvents or aerosol detergents.

Disposal



Device 

At the end of its life, the appliance must not be disposed of in household rubbish. Enquire about the options for environmentally-friendly disposal.



Packaging

All packaging and packaging materials that are no longer required can and should be recycled.

Package Contents

Please check whether the product is complete and inform us **within 14 days of purchase** if anything is missing. Your 5.1 system packaging should contain the following items:

- subwoofer with integrated amplifier
- 5 satellite speakers
(1 x Centre, 2 x Front, 2 x Rear) with connection cables
- 3 connection cables
(3.5 mm stereo plug → 2 cinch plug)
- power adapter
- this manual and warranty documents

Connections and Controls

Front of the active Subwoofer

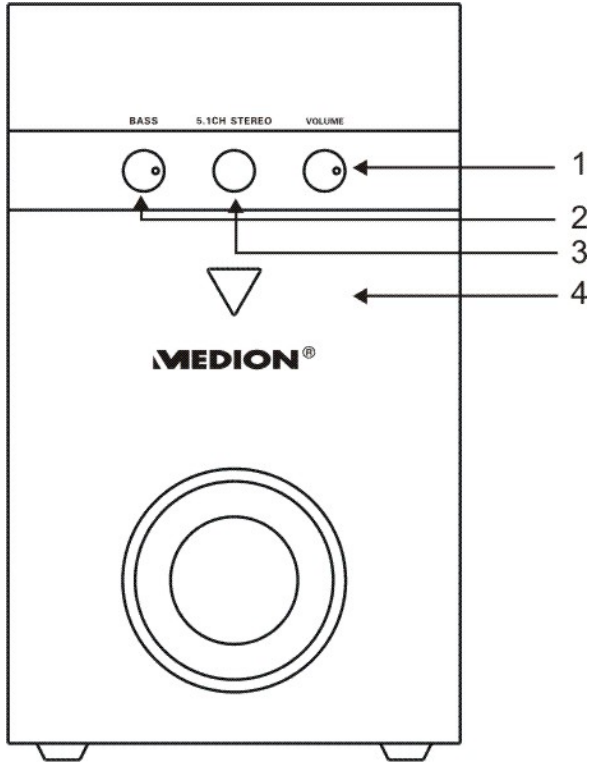

(III. Front of the active Subwoofer)

- 1 - Total volume
- 2 - Volume control for bass / subwoofer
- 3 - 5.1 Input / Switch AUX
- 4 - POWER LED indicator

Rear of the active Subwoofer

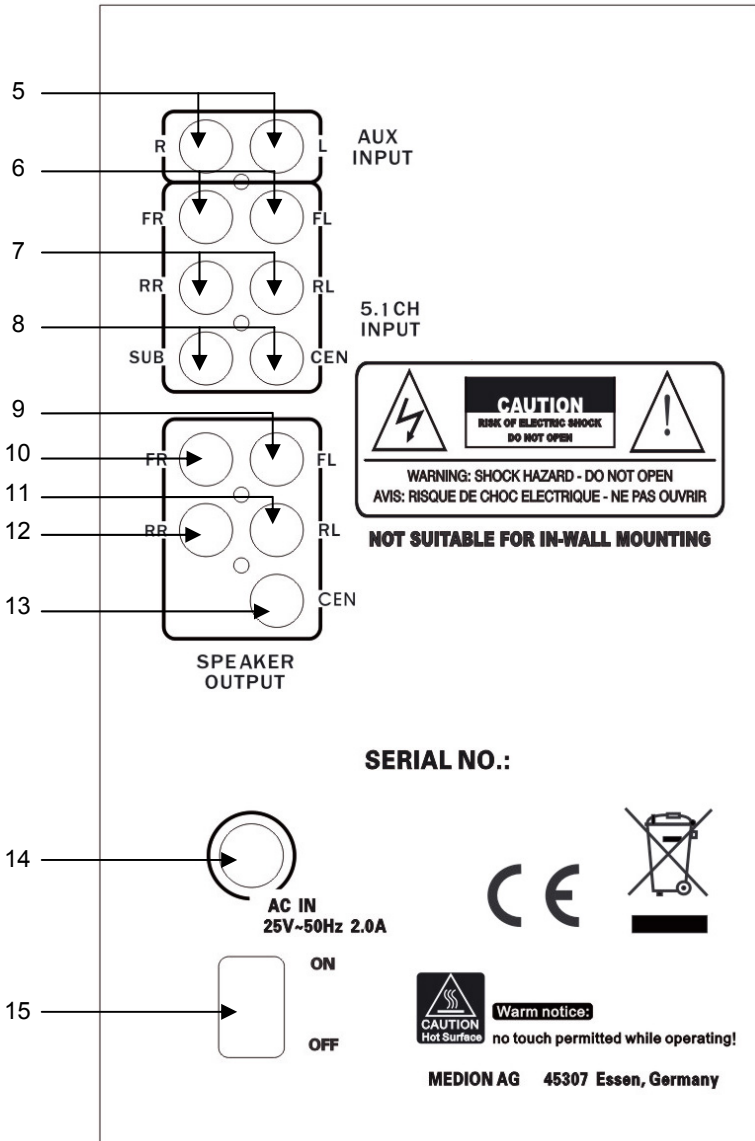

[III: Rear of the active Subwoofer]

- 5 - Cinch connector for stereo input
- 6 - Cinch connector for 5.1 input "**Front**"
- 7 - Cinch connector for 5.1 input "**Rear**"
- 8 - Cinch connector for 5.1 input "**Subwoofer/Centre**"
- 9 - Speaker connector for **Front** speakers **left**
- 10 - Speaker connector for **Front** speakers **right**
- 11 - Speaker connector for **Rear** speakers **left**
- 12 - Speaker connector for **Rear** speakers **right**
- 13 - Speaker connector for Centre speaker
- 14 - Connector for power adapter AC IN
- 15 - ON/OFF switch

Setting Up

With this 5.1 System you can reproduce surround sound effects.

To reproduce these surround sound effects the following conditions must be met:

- the medium (usually DVD film) must support surround sound.

Remark:

Depending on the movie title, surround sound effects may vary in intensity.

- the connected source (DVD-player, sound card, etc) must support the required connections and functions.

Furthermore, your 5.1 system must be properly connected and positioned, so that the optimal surround sound effect can be heard:

Positioning the 5.1 System

Position the loudspeakers in such a way that the audience is in the centre. The satellite speakers may be distributed freely. The two rear satellite speakers have longer cables, so that they can be positioned according to the space in the room:

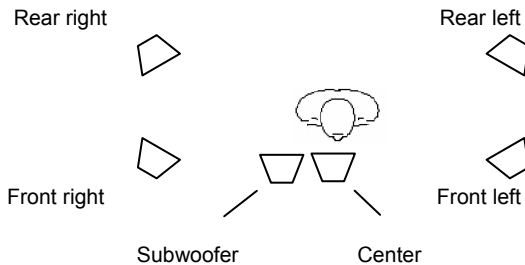

Loudspeaker	Description
Front left	For sound from the front
Front right	
Rear left	For sound from the back
Rear right	
Centre	For sound in the centre
Subwoofer	This position may vary

2. Connecting the Subwoofer to a Sound Source

Your 5.1 system can take input from a sound card, a DVD-player or another suitable sound source with the corresponding output connections.

Tip

3.5mm stereo cinch male plugs are required. When not available, adapters are required.

Attention!

Digital connections are not supported and can damage the device.

Ensure the output device is powered off before connecting any cables.

Locate the output connections of the sound source (sound card, DVD-player, etc) and connect the device with the supplied cables.

The connections are usually colour-coded. The colours might vary slightly. Check the user manual of your device as a safeguard.

Use the drawing and the table below as a guide:

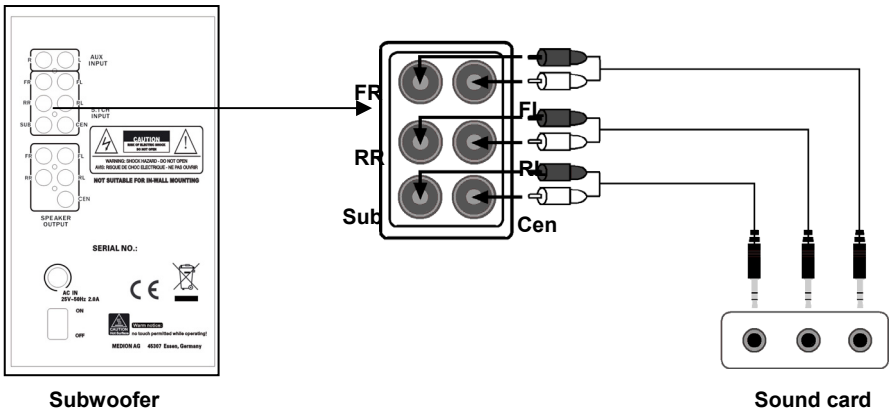

[III.: Connection 5.1 channel output on PC sound card]

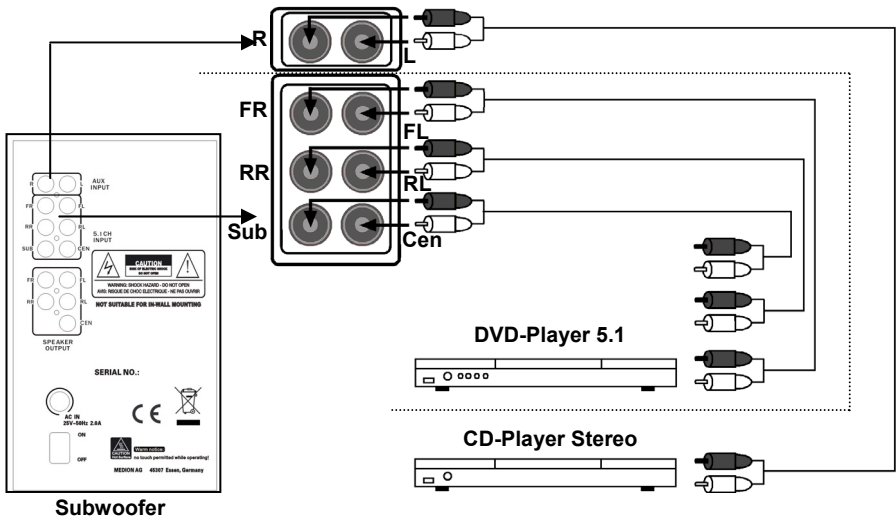

[III.: Connection 5.1 channel input and AUX input]

Connection on the subwoofer (⇒ p. 6)	Connection on the source
6, Front R - Cinch red 6, Front L - Cinch white	3.5mm stereo cinch plug
7, Rear R - Cinch red 7, Rear L - Cinch white	3.5mm stereo cinch plug
8, Center – Cinch white 8, Subwoofer – Cinch red	3.5mm stereo cinch plug

3. Connecting the Power Adapter

Connect the supplied power adapter to the AC In connector on your 5.1 system (⇒ p. 6, 14) and insert the power plug into an easily accessible power socket. Do **NOT** switch on the 5.1 system yet.

Operation and Handling

1. Check that all volume controls are set to the lowest position. Turn the controls on the front (⇒ p. 5, [1] & [2]) of the 5.1 system anti-clockwise until you feel resistance.
2. Switch on your sound source and play a suitable sound.
3. Now switch on the 5.1 system by flipping the power switch (⇒ p. 6, [15]) into position **I/ON**. An LED (⇒ p. 5, [4]) will show to indicate the 5.1 system is in operation.
4. Switch on the desired source (⇒ p. 5, [3]) to AUX or 5.1 Input.
5. Turn the total volume control and the volume control for bass carefully clockwise until a comfortable volume level is reached and a balanced sound is achieved. Turning the control anti-clockwise lowers the volume.
6. To turn off the volume, switch off the 5.1 system (⇒ p. 6, [15]) (position **0/OFF**) and then switch off the sound source. The power supply will be interrupted by pulling the power adapter out of the power supply socket.

Service

Support in the Event of a Malfunction

Malfunctions can sometimes be caused by trivial issues and sometimes be complex in nature and require thorough analysis.

- Start with a careful visual inspection of all cable connections. If the indicators are not lit, then check whether the 5.1 system is properly supplied with power.
- Switch off the device and check all cable connections. When you are certain that the supply of power operates flawlessly and that all connections are correct, then switch on the device again.
- If the sound is distorted or too low, then adjust the volume controls until the desired volume level is obtained.
- If you do not hear any sound, then this could be caused by:
 - the speakers are without power (wrong cabling).
 - the volume control is turned down.
 - sound output is deactivated, muted or faulty (wrong format).

Do You Require Additional Support?

If the suggestions in the previous section did not solve your problem, please contact us. It would help us if you could supply the following information:

- The configuration of your computer
- Are you using any other peripheral devices?
- Are any messages displayed on the screen?
- What were you doing when the malfunction occurred?
- Which steps have you already taken to solve the problem?
- If you have already received a customer number, please supply it to us.

Specifications

- **Speaker System** Active 5.1 surround sound system
- **Power adapter**
Input AC 230V ~ 50Hz
Output AC 25V ~ 50 Hz, 2000mA
- **Connections**
In:
Power connection for power adapter
Cinch plugs for:
 - front right (red), left (white)
 - subwoofer (red) / centre (white)
 - rear right (red), left (white)**Out:**
Cinch plugs for:
 - front right, left
 - centre
 - rear right, left

Copyright © 2007, 03/08

All rights reserved.

This manual is protected by copyright laws.

The company **Medion**[®] is the owner of the copyright.

Trademark:

All appearing trademarks are the property of their respective owners.

Technical specifications and optical characteristics are subject to change without notice. Printing errors might occur.