

This product is certified in accordance with ECE R 44/04.

ECE R44/04
UNIVERSAL
0-13 kg

E1

Group
0+



0-12
months



0-13 kg



Never place a reversed car seat on a front seat with an airbag.

Emmalunga®



first CLASS 

Instruction Manual

IMPORTANT KEEP FOR FUTURE REFERENCE

Your child may be hurt if you do not follow these instructions. For the proper use of this product, be sure to read this User's Manual carefully.

UK



Dear Parents,

Welcome to Emmaljunga – your premium pushchair and child's car seat manufacturer from Sweden. Through constant product development in the areas of safety and functionality, we see our most important task as ensuring that your child is transported from birth in the safest and most comfortable child's seat possible.

In developing Emmaljunga First Class 0+, safety, ease of operation, comfort and design are always our top priorities.

Emmaljunga First Class 0+ has been approved under the most recent ECE R 44/04 guidelines (June 2005) of the European safety regulations for car safety seats, and meets the most stringent safety requirements. The seat is intended for the transport of children aged 0 – approx. 12 months, weighing up to 13 kg.

Emmaljunga First Class 0+ has been specially developed to give your child the best possible protection in the event of abrupt braking or a collision. No child car seat can offer absolute safety in the event of an accident, but its use will significantly reduce the risk of injury.

A safety product is only safe when it is installed and used in accordance with the operating instructions. So for the sake of your child, please take the time to read these carefully.

Emmaljunga Barnvagnsfabrik AB
Automotive Safety Division

CONTENTS

| | |
|---|----|
| 1. Contents..... | 4 |
| 2. Important safety information..... | 5 |
| 3. Overview..... | 10 |
| 4. General functions | |
| 4.1 Adjusting the head protection/length adjustment..... | 12 |
| 4.2 Use of the 5-point harness..... | 13 |
| 4.3 Carrying handle/ Button on the carrying handle..... | 15 |
| 4.4 Hood..... | 16 |
| 4.5 Nappy storage..... | 17 |
| 4.6 Storage of the instruction manual..... | 17 |
| 5. Use in the car | |
| 5.1 Instruction for use in the car..... | 18 |
| 5.2 Install Emmaljunga First Class 0+ in the car..... | 19 |
| 5.3 Remove Emmaljunga First Class 0+ from the car..... | 20 |
| 6. Care and maintenance | |
| 6.1 Care instructions..... | 21 |
| 6.2 Removing the fabrics/changing the fabrics..... | 21 |
| 6.3 Re-fitting the fabrics..... | 22 |
| 7. Guarantee..... | 23 |
| 7.1 Procedures in the event of activation of the guarantee..... | 23 |

CONTENTS OF THE BOX

- 1 pc First Class 0+ car seat incl. fabrics
- 1 pc Hood
- 1 pc Instruction manual

2. IMPORTANT SAFETY INFORMATION

Please read through the operating instructions carefully. Emmaljunga First Class 0+ is a safety product and is only safe when it is installed and used in accordance with the specifications!

For the future use of Emmaljunga First Class 0+ it is important to keep the operating instructions in their place behind the headrest.

If you fail to observe the instructions for the assembly and use of the product in full, then your child could be seriously injured and/or your Emmaljunga First Class 0+ could be damaged.

WARNING! Never attach Emmaljunga First Class 0+ to a front seat with an airbag as this could result in fatal or severe injury. This does not apply to side airbags.

WARNING! Always use the 5-Point harness when you lay your baby in the Emmaljunga First Class 0+, even when you are only carrying it and using it outside your vehicle.

WARNING! Any alteration or accessory installation to Emmaljunga First Class 0+ or to the vehicle seatbelt is prohibited. Make sure that you follow the instructions for assembling and using the Emmaljunga First Class 0+ correctly.

WARNING! Check before use that all locks are fastened and that the Emmaljunga First Class 0+ is correctly assembled.

WARNING! Accessory or replacement parts which are not approved by the manufacturer should not be used.

WARNING! Never leave a child unsupervised in the Emmaljunga First Class 0+! You are responsible for the child's safety.

Emmaljunga First Class 0+ is intended for the transport of children aged 0 – approx. 12 months, weighing up to 13 kg.

Emmaljunga First Class 0+ has been approved under the most recent ECE R 44/04 guidelines (June 2005) of the European safety regulations for car safety seats. There is a registration number on the plastic shell which must not be removed. Emmaljunga First Class 0+ is a “universal” support system for children and is suitable for all car seats facing the direction of travel fitted with 3-point automatic or static seat belts, approved pursuant to UN/ECE Regulation R16 or other equivalent regulations.

Legal provisions on the use of children's car seats differ greatly from country to country. For further

enquiries on the precise requirements in your country, please consult your stockist. Also, when instructions are unclear and you require more detailed explanations or when you have further questions, please consult your authorised Emmaljunga First Class 0+ stockist. A list of these may be found at www.emmaljunga.se.

The safety tips and instructions in these operating instructions cannot cover all possible circumstances and unforeseeable situations that may arise. It is self-evident that common sense, care and attention are factors which cannot be built into this product and must come from the individual(s) who use and maintain Emmaljunga First Class 0+. It is important that these instructions are understood by everyone who uses this product and its accessories. Please inform every person who uses this product, even if only for a short period, about the correct use of this product and its accessories.

Always check beforehand that the carrying handle is locked into the carrying position before you lift the Emmaljunga First Class 0+.

Emmaljunga First Class 0+ may be used both on the front seat (WARNING! In this case, a front air bag must not be activated), and on the back seat, albeit exclusively against the direction of travel. Back seats which fold back must be locked.

Never use Emmaljunga First Class 0+ on a vehicle seat which is installed against the direction of travel or sideways.

Your Emmaljunga First Class 0+ may only be used in connection with an approved 3-point automatic or static seat belt.

The correct path of the seatbelt is important for safety. The seat belt must be attached along the blue markings on the Emmaljunga First Class 0+. A detailed explanation is given in Chapter 5.2. Never thread the belt in any other way than the described one.

Make sure that the seat belt and the 5-point belt of the Emmaljunga First Class 0+ are always correctly installed, are fixed and taut and not twisted. Check that the lap belts always run as snugly as possible over the lap of your baby. Do not place any blankets between your child and the belt.

After an accident, the Emmaljunga First Class 0+ and the car safety belt must be immediately replaced. Damage may not necessarily be recognisable but after an accident, Emmaljunga First Class 0+ will no longer be safe.

The manufacturer can only guarantee the safety of the seat for the first purchase. Due to wear and tear, used products no longer offer comprehensive protection. We would not recommend that you ever deploy used products since you will never know what has happened to them.

You are advised against using safety car seats for more than 5 years after the year of purchase. Through an ageing process for plastic, due to solar radiation, etc., the properties of the product may change imperceptibly.

Emmaljunga First Class 0+ is only suitable for carrying children. Never use Emmaljunga First Class 0+ as a bed for your child. Do not allow children to play in it or with it.

The car's brake mechanism must always be engaged when you secure Emmaljunga First Class 0+ in your car or release it.

Never leave Emmaljunga First Class 0+ in hazardous places, even when it is empty.

Never push or place anything under the Emmaljunga First Class 0+, since it may become unfastened in the event of a collision.

Always secure the Emmaljunga First Class 0+ within the vehicle in such a way that it cannot be jammed by a movable seat or vehicle door during everyday use.

Where possible, avoid placing a passenger in the seat behind the Emmaljunga First Class 0+. If this is not possible, place the lightest person in this position. In the event of an accident, it is more likely that your baby will be injured with a heavy passenger than with a light one.

All the occupants of a vehicle must keep their belts fastened at all times, since unsecured adults or children may be thrown against other occupants in the event of a collision, resulting in serious injuries or even death.

For multi-purpose vehicles, do not carry any children in the boot behind the back seats unless there is a special reserve installation for children.

Do not leave any luggage or loose objects unsecured in your vehicle, since in the event of a sudden braking manoeuvre or collision, these may be sharply accelerated and could cause serious injury.

Never leave the Emmaljunga First Class 0+ loose in your vehicle, always ensure it is secured.

Never take your child out of the Emmaljunga First Class 0+ during travel for whatever reason. If you need to take care of your baby, find a safe parking space and stop.

Keep your Emmaljunga First Class 0+ in a suitable place when you don't require it. Don't place any heavy objects on the Emmaljunga First Class 0+. Never place objects on the hood of the Emmaljunga First Class 0+.

Check the Emmaljunga First Class 0+ regularly for wear and tear.

Check before each journey that all foldable vehicle seats are safely locked.

Children should not play with the Emmaljunga First Class 0+ or any of its component parts.

Always use the original Emmaljunga First Class 0+ cover and never exchange it for any other cover. The original cover is an integral part of your child car seat and must be used for it to be effective.

Emmaljunga First Class 0+ can become very hot due to the effect of sunlight, and contact with these parts can burn your child's skin. Before you lay your child in the Emmaljunga First Class 0+, always check that the surface consisting of fabric, metal or plastic components is not too hot or cover the Emmaljunga First Class 0+ with a cloth if your vehicle is parked in strong sunlight.

The seatbelt buckle of your Emmaljunga First Class 0+ has been developed in such a way that it can be rapidly opened in an emergency. It is thus not childproof and children could learn how to open it themselves. Children should thus be prevented from ever playing with the lock or with other parts of the seat.

Contact your doctor or clinic staff before you transport newly born babies in the Emmaljunga First Class 0+.

Do not let your baby lay for several hours in the Emmaljunga First Class 0+

Do not place the Emmaljunga First Class 0+ near to the edges of tables or on soft surfaces such as mattresses and pillows, since the rocking or movement of the child within the seat can shift its position, and it may fall down and injure the child.

Never rest the Emmaljunga First Class 0+ on top of a shopping trolley.

Keep the Emmaljunga First Class 0+ away from heating apparatus and other sources of warmth.

Do not leave your car keys in the vehicle when you attach the Emmaljunga First Class 0+ inside. Many vehicle models are equipped with automatic locking mechanisms which lock automatically after a given time period if you close the doors from the outside. In this way, you will avoid locking your child inside the car with your keys (while locking yourself out of the vehicle).

This product must be maintained by the user. Please follow the care and maintenance instructions. The movable parts of the Emmaljunga First Class 0+ must never be lubricated in any way.

3. OVERVIEW

- ① Car-Seat shell
- ② Harness buckle
- ③ Shoulder straps
- ④ Harness buckle pad
- ⑤ Carrying handle
- ⑥ Button to adjust the carrying handles
- ⑦ Belt mover for the car waist seat belt
- ⑧ Belt mover for the car shoulder seat belt
- ⑨ Strap to adjust the 5-point harness/ To use when you shorten the shoulder straps
- ⑩ Button to make First Class 0+ shoulder straps longer
- ⑪ Handle lock to attach onto the base and/or to the car-seat adapter
- ⑫ Handle to adjust the head protection and the lying curve.
- ⑬ Storage for the instruction manual
- ⑭ Nappy storage
- ⑮ Head protection
- ⑯ 5-point harness
- ⑰ Attachment hooks for base and car-seat adapter
- ⑱ Sticker for instruction and warning for airbag

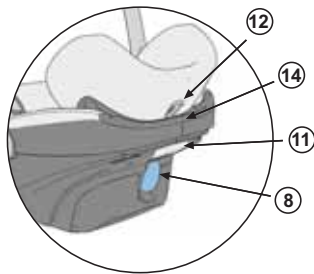
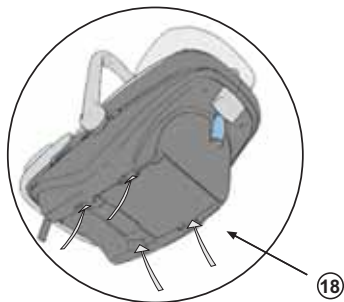

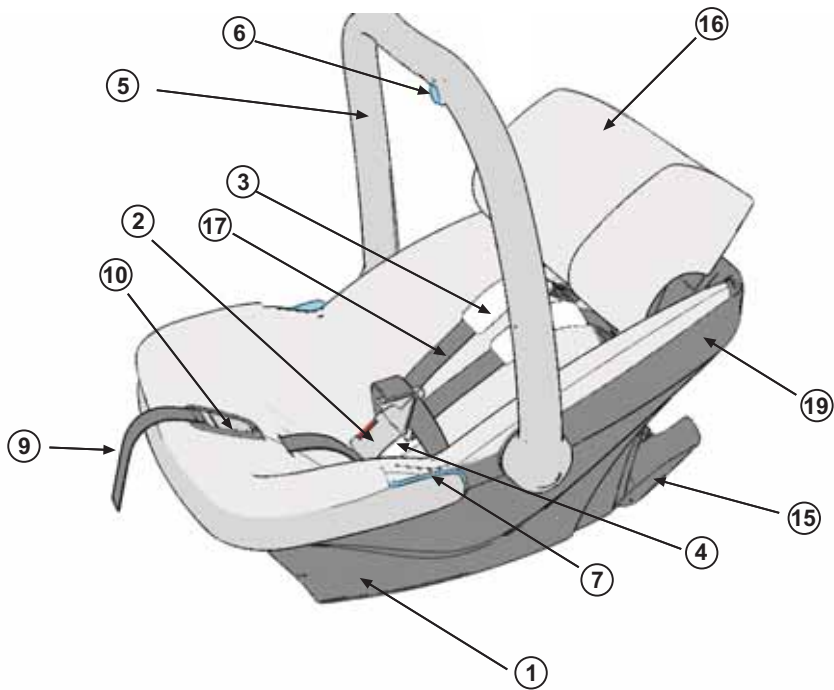

4. GENERAL FUNCTIONS

4.1 Adjusting the head protection/ Length adjustment

By pushing the head protection upwards or downwards you can adjust the head protection and the lying curve optimal according to the size of the child. You will therefore always get the best fit and safety.

Newborn: Headprotection should be in its lowest position (The lying curve levels automatically)

Older babies: Pull the head protection upwards.(The lying curve becomes deeper)

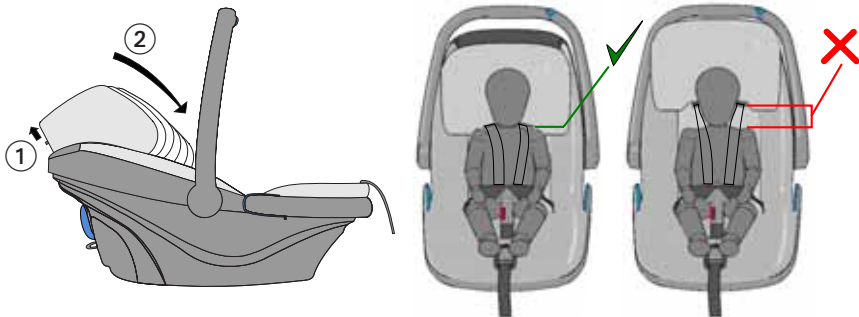

The adjustment of the head protection can be done with the child in the seat or out of the seat.

Pull up the handle to adjust the head protection (1) and at the same time move the head protection into the desired position.

Head protection should be placed so that the 5-point harness comes out just above the child's shoulder.

Make sure that the head protection clicks into position with a "Click".

WARNING! The correct positioning of the head protection is of great importance for the safety of your baby.

4.2 Use of the 5-point harness

Opening the harness

Open the 5-point harness, by pressing the central harness buckle (1).

Place the shoulder straps and the crutch strap aside.

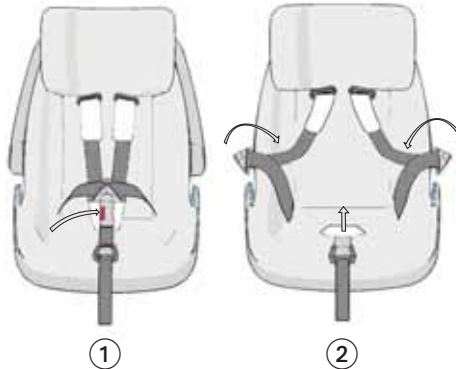

Close the harness

Place the baby in the Emmaljunga First Class 0+. Make sure that the shoulder straps are placed so that they will come out exactly above the baby's shoulder. Adjust the head protection upwards or downwards, if necessary (see 4.1)

Place the baby's arms through the shoulder straps. Pull the waist strap toward the central harness buckle in between the baby's legs.

Put together the harness locks (4+5) and place the locks into the central lock.

The straps must click in and lock with an audible "Click" (6).

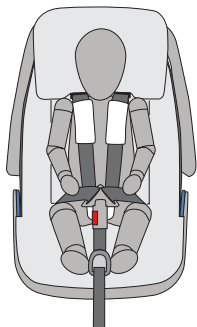
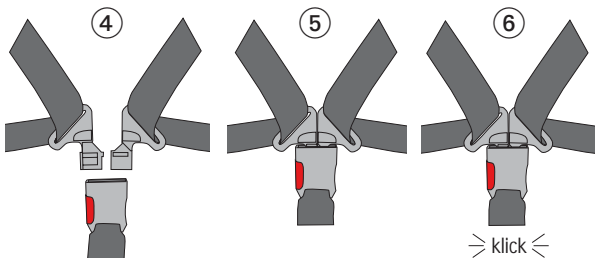

Tighten the 5-point harness

Tighten the 5-point harness by pulling the waist strap (1).

Extend the 5-point harness

Extend the shoulder straps by pressing the central adjustment button which is placed in between the baby's legs (2) and pull the shoulder straps at the same time.

WARNING!

The harness must be fitted tightly during transport or the car journey. The tighter the harness is strapped the better protected is the baby. The waist strap must run as far down as possible over the child's waist.

There must only be a maximum play of two fingers in between the harness and the child.

The harness must never be used if damaged.



1

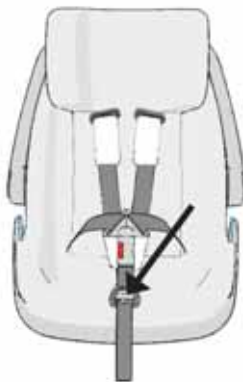

2

4.3 Carrying handle/ Button on the carrying handle

You can adjust the carrying handle with one hand by pressing the small blue button on the handle and at the same time moving the carrying handle into the desired position.

The carrying handle has 4 functions (+2 safety positions A+B, marked in light grey):

Handle position (1): Locking of the cradle function (e.g to feed the baby)

Handle position (2): When you place the baby in First Class 0+, or when you use First Class 0+ on the pram.

Handle position (3): To carry

Handle position (4): In the car

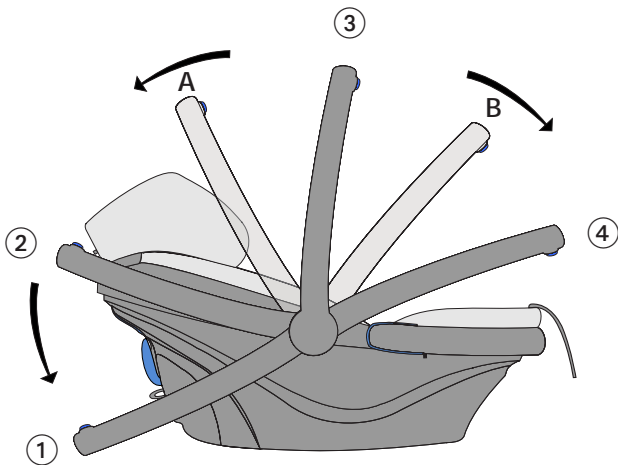

4.4 Hood

Attaching the hood: attach the hood with the hood attachment into the car seat hood locks.

Remove the hood: Take away the hood by gently pulling the hood attachments out of the car seat hood locks.

Adjust the hood: Adjust the hood by gently pulling the hood backward or forward.

WARNING!

Never carry Emmaljunga First Class 0+ by the hood, only carry it by the handle.

Do not place any heavy objects on the hood.

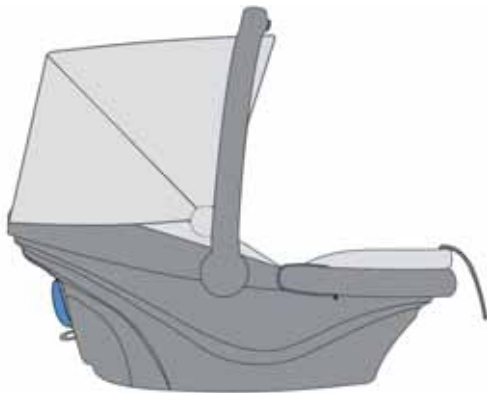

4.5 Nappy Storage

Open the Nappy storage by pressing the plastic handle lightly downwards. To close the storage, push it back into its original position. Do not place any heavy objects in the nappy storage.

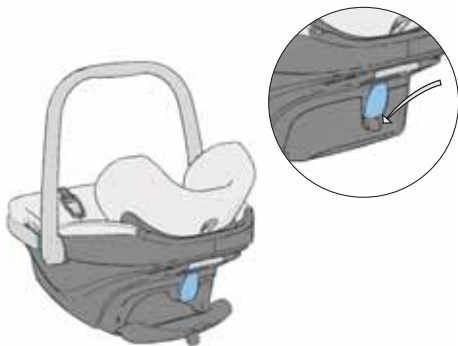

4.6 Storage of the instruction manual

Behind the head protection is the manual. Please always put the manual back into this place.



5. USE IN THE CAR

5.1 Instruction for use in the car

Please read the safety instructions thoroughly on page 5-9 before you use Emmaljunga First Class 0+. Should you not follow the instruction for assembly and usage completely, this could cause serious injury to your child.

Emmaljunga First Class 0+ can be used in the front seat (WARNING! a front air bag must not be activated) and in the back seat. However, the car seat can only be used in vehicle seats which are installed in the driving direction. Folded backseats must be in upright position and locked into position. Never use Emmaljunga First Class 0+ in vehicle seats that are turned against the driving direction or that are attached sideways.

Your Emmaljunga First Class 0+ can only be used with an approved 3-point harness, automatic seatbelts or static seat-belt.

Emmaljunga First class 0+ fits all seats installed in the driving direction in the car. We recommend that before you purchase, test the car seat to ensure that it can be installed correctly. In some cases it can be that the seat belts are positioned too far ahead, so that a correct installation is impossible. It can also be that, the locking part of the seat belt is too far down so that you cannot attach the seat belt in the blue belt movers on Emmaljunga First Class 0+. In these exceptional cases we would ask you to choose a different seat. Any questions please contact your authorised Emmaljunga First Class 0+ retailer.

Make sure that the car seat, even when not in use, is always attached in the car. Passengers can be injured if the car brakes abruptly and the car seat is not properly attached.

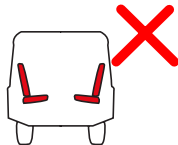
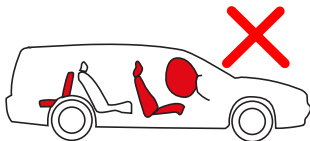
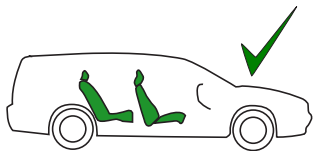

5.2 Install Emmaljunga First Class 0+ in the car

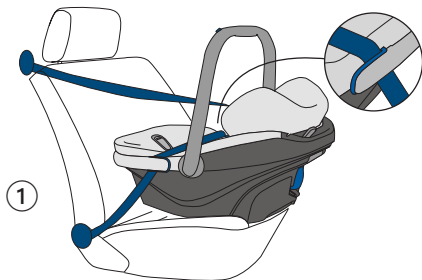

Picture 1: Secure the baby with the 5-point harness in Emmaljunga's First Class 0+ (see 4.2).

Place the Emmaljunga First Class 0+ rearwards in the vehicle seat, against the driving direction. Place the waist car seat belt through the blue belt movers for the waistbelt (one on each side) on the Emmaljunga First Class 0+.



Picture 2: Click the car seat belt into the car seat belt lock. Make sure that it clicks into place with an audible "click".

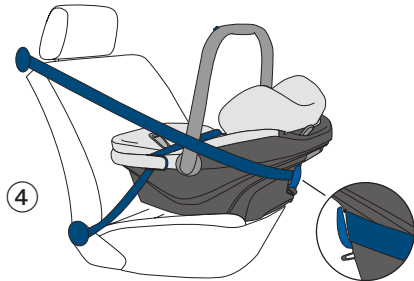
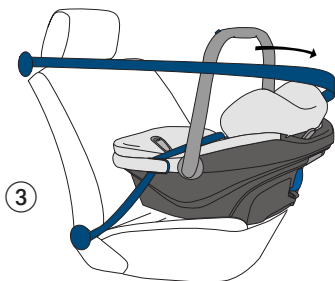

Picture 3+4: Pull the cars diagonal seat belt over the head protection (3) of First Class 0+ and attach it into the blue clip on the back of the car seat.

WARNING! This step is very important to go through for the safety of your child

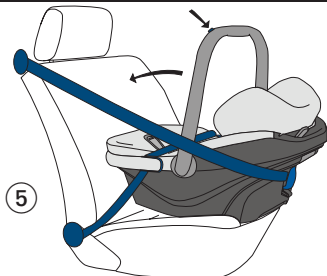

Picture 5: Move the carrying handle forward (to the foot end of the baby). The position of the carrying handle is easily adjusted by pressing the blue button on the carrying handle.

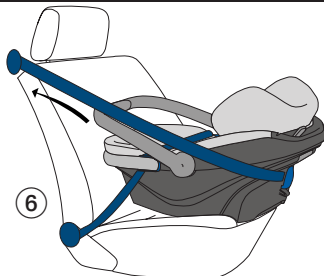

Picture 6: Tighten the seat belt hard and make sure that it is not twisted in any place. Make sure that the seat belt is correctly tightened through the blue belt movers by the baby's pelvis and behind the head barrier.

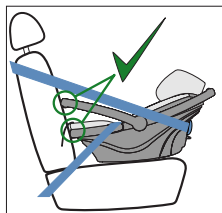

5.3 Remove the Emmaljunga First Class out of the car

Open the seat belt by clicking on the harness buckle.

Pull the seat belt through the belt mover and remove the seat belt from the Emmaljunga First Class 0+.

Place the carrying handle in carrying mode (upright position) The carrying handle can be adjusted by pressing on the blue button on the carrying handle. You can now lift the Emmaljunga First Class 0+ out of the car. Make sure that your child is still fastened in the Emmaljunga First Class 0+ 5-point harness.

6. CARE AND MAINTENANCE

6.1 Care instructions

The care of the Emmaljunga First Class 0+ should always take place outside the car.

The plastic shell can be washed with luke warm water and mild soap/detergent. Please do not use any aggressive detergents since they can cause damage to the surface.

The harness buckle of the 5-point harness can only be washed with warm water. Avoid using detergents.

Wash the fabrics by hand maximum 30 degrees C.

The fabrics must not be tumble dried. Only drip dry.

Washing instructions are available on the wash label.

The silver coated plastic parts are sensitive to scratches.

Avoid bumps that could cause damage to the surface.

If you should leave the car seat as airline luggage, please wrap it well.



WARNING!

Do not remove the energy absorbing padding (the foam material) which the car seat shell is covered with. The padding is part of a well-developed safety system and must not be removed.

6.2 Removing the fabrics/ changing the fabrics (see picture on next page)

Picture 1. Make sure that the 5-point harness is open when you want to remove the seat-fabrics. Remove the seat-fabrics from the head protection. The fabric on the head protection is sewn in with the backrest padding. You can now remove the top part of the fabrics.

Picture 2. To remove the other part of the fabrics, open the two zippers by the back.

Picture 3. Release the rubber loops, which are situated at the lower part by the blue belt movers. Open both press studs which are located next to the blue belt movers.

Picture 4. You can now remove the other part of the seat fabrics.

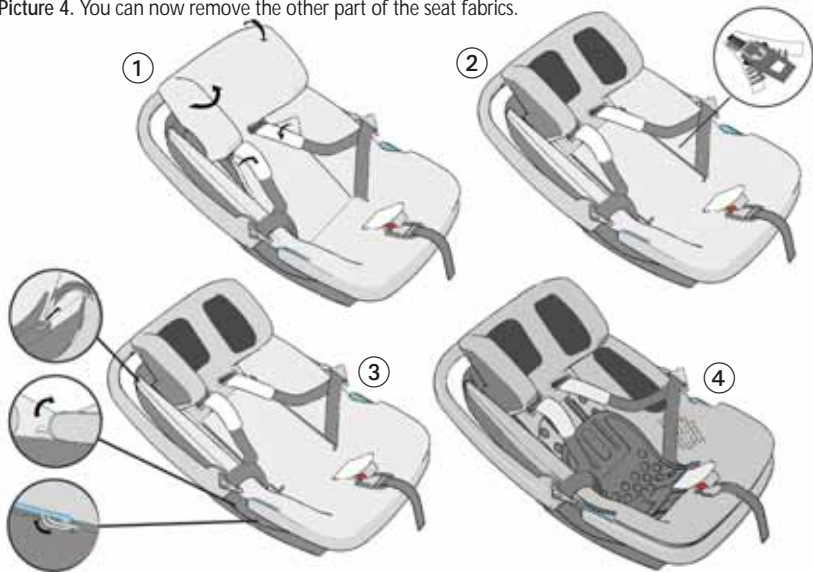

6.3 Re-fitting the fabrics

Make sure that the 5-point harness is open.
Perform every step in 6.2 to remove the fabrics in reversed order to put on the fabrics again.
Make sure you start with the lower part of the fabrics.

7. GUARANTEE

7.1 Procedures in the event of activation of the guarantee

In the event of activation of the guarantee, please consult your authorised Emmaljunga First Class 0+ stockist, which where necessary, shall send the child seat to the manufacturer with a description of the complaint and the original purchase receipt with the date of purchase. The guarantee period starts at the moment of purchase.

Emmaljunga Barnvagnsfabrik AB in Sweden guarantees that this product meets the safety requirements of the current European ECE R 44/04 regulation. Emmaljunga grants the legally prescribed guarantee for material and manufacturing defects pursuant to EU law on warranties. Material and manufacturing defects are defects which the product already possesses at the time of purchase. It is therefore assumed that any defects which appear in the first 6 months following purchase were also present at the time of the purchase. These shall be eliminated by repairing or changing the relevant parts.

Complaints due to damage or defects arising because of accidents, damage during flights, mishandling, inadequate care or wear and tear shall not be eligible. For this reason, please follow the instructions for use and care of your product.

The guarantee shall not apply in the following cases:

- If the product is not repaired by suppliers recognised by Emmaljunga Barnvagnsfabrik AB.
- If product complaints are submitted without the original purchase receipt.
- If the defect is attributable to careless use or maintenance.
- If the repairs are carried out by third parties.
- If discolouring or damage to fabric arises due to excessive exposure to sunlight.
- If the defect was caused by an accident.
- If the ECE quality label and the running serial number is found to be damaged.
- If normal wear and tear arises through everyday use.
- Scratches arising after the purchase of the product shall not be eligible as complaints. This also applies to silvered plastic components.

Emmaljunga®

Made in Sweden
Since 1925



Instruction manual for Emmaljunga First Class 0+
2007 Emmaljunga Barnvagnsfabrik AB
All rights reserved

Emmaljunga Barnvagnsfabrik AB
Box 2056, SE-280 22 Vittsjö
Sweden

Internet: www.emmaljunga.se