

NSK

MEGATORQUE[®] MOTOR SYSTEM

User's Manual (ESB Driver Unit System)

Instructions for PROFIBUS

M-E099SB0C2-126

NSK Ltd.

Document Number: C20126-02

Limited Warranty

NSK Ltd. warrants its products to be free from defects in material and/or workmanship which NSK Ltd. is notified of in writing within, which comes first, one (1) year of shipment or 2400 total operation hours. NSK Ltd., at its option, and with transportation charges prepaid by the claimant, will repair or replace any product which has been proved to the satisfaction of NSK Ltd. to have a defect in material and/or workmanship.

This warranty is the sole and exclusive remedy available, and under no circumstances shall NSK Ltd. be liable for any consequential damages, loss of profits and/or personal injury as a result of claim arising under this limited warranty. NSK Ltd. makes no other warranty express or implied, and disclaims any warranties for fitness for a particular purpose or merchantability.

Copyright 2003 by NSK Ltd., Tokyo, Japan

All rights reserved.

No part of this publication may be reproduced in any form or by any means without permission in writing from NSK Ltd.

NSK Ltd. reserves the right to make changes to any products herein to improve reliability, function or design without prior notice and without any obligation.

NSK Ltd. does not assume any liability arising out of the application or use of any product described herein; neither does it convey any license under its present patent nor the rights of others.

Patents issued and patents pending.

“MEGATORQUE” is a registered trademark of NSK Ltd. in Japan, and that of NSK Precision America, Inc. in the United States of America.

Introduction

◎ About This Manual

- This manual describes the interface with PROFIBUS. Other matters related to the Megatorque Motor System, refer to the User's Manual for ESB Driver Unit.
- Please read thoroughly this manual for safety use of the Megatorque Motor System.

◎ Limited Function for ESB Driver Unit Compatible With PROFIBUS

- The following functions are not available for the ESB Driver Unit compatible with PROFIBUS communication.
 - ◇ Velocity control and torque control mode operation.
 - ◇ Operation by pulse train position command.
 - ◇ Acceleration profiling function.

(Blank Page)

Contents

1. Specifications	1-1	4.4. Output Signal	4-6
1.1. PROFIBUS Specifications	1-1	4.4.1. Driver Unit Ready (DRDY) / Warning (OVER)	4-6
1.2. Dimensions of Driver Unit	1-1	4.4.2. In-Position (IPOS)	4-7
1.3. Specifications of Control Input and Output Signals	1-2	4.4.3. Processing Pulse Generation (BUSY)	4-7
1.4. Validity of Inputs and Outputs by Operation Mode	1-3	4.4.4. Brake (BRK)	4-7
1.4.1. Combination of Inputs and Outputs in PROFIBUS Mode and Maintenance Mode	1-3	4.4.5. Brake Control (BRKC)	4-7
2. Interface Specifications	2-1	4.4.6. Home Position Defined (HCMP)	4-8
2.1. CN2 Connector	2-1	4.4.7. Home Return Completed / Home Position Detected (HOME)	4-8
2.1.1. CN2 Pin-Out	2-1	4.4.8. Velocity Report (SPD)	4-9
2.1.2. Signal Code and Function	2-2	4.4.9. Move / Channel Acknowledgement (ACK_PRG x)	4-9
2.2. PROFIBUS-DP Interface	2-3	4.4.10. Emergency Stop State (EMSTA)	4-11
2.2.1. CN5 (PROFIBUS) Pin-Out	2-3	4.4.11. State of Over-travel Limit (OtxA)	4-11
2.2.2. SW1: Termination Resistor Switch	2-3	4.4.12. State of Home Position Limit Sensor (HLSA)	4-11
2.2.3. SW2 and Sw3: Node Address Switch	2-3	4.4.13. Target Proximity / In Target (NEARA, NEARB)	4-12
2.2.4. Indication of STATUS LED	2-4	4.4.14. Processing Confirmed / Data Processed Result (PRM_ACK / PRM_STS)	4-13
3. Setting	3-1	4.4.15. Parameter Number (PRM_GET_NO)	4-13
3.1. Termination Resistor	3-1	4.4.16. Parameter Contents (PRM_GET_DATA)	4-13
3.2. Node Address	3-1	5. Command Interface	5-1
3.3. Configuration by GSD File	3-1	5.1. Outline of Command	5-1
4. Input and Output Specifications	4-1	5.2. Parameter Interface	5-2
4.1. Data Packets	4-1	5.2.1. Procedures for Writing Parameter, Executing Command and Starting Operation	5-2
4.2. I/O and Signal Format	4-1	5.2.2. Procedures for Reading out Parameters / Monitoring Operating Conditions	5-3
4.3. Input Signal	4-2	5.3. Program Interface	5-4
4.3.1. Emergency Stop (EMST)	4-2	5.3.1. Procedures for Editing Internal Program	5-4
4.3.2. Servo ON (SVON)	4-2	5.3.2. Procedure for Reading out Internal Program	5-5
4.3.3. Start Programmable Indexer (RUN)	4-2	5.4. Command List	5-6
4.3.4. Stop (STP)	4-2	5.4.1. Parameter	5-6
4.3.5. Clear Position Error Counter / Alarm (CLR)	4-3	5.4.2. Managing Command	5-9
4.3.6. Integration OFF / Lower Velocity Gain (IOFF)	4-3	5.4.3. Operation Command	5-9
4.3.7. Clamp cancel (CLCN)	4-3	5.4.4. Editing Program	5-10
4.3.8. Home Return Start (HOS)	4-3	5.4.5. Program Command	5-10
4.3.9. Override (ORD)	4-4	5.4.6. Monitor	5-11
4.3.10. Internal Program Channel Select (PRGx: x=0 to 5)	4-4	5.4.7. Processing Decimal Place	5-15
4.3.11. Jog (JOG)	4-4		
4.3.12. Jog Direction (DIR)	4-5		
4.3.13. Write / Read Parameter, Process Type (PRM_REQ / PRM_OPE)	4-5		
4.3.14. Parameter Number (PRM_SET_NO)	4-5		
4.3.15. Writing Data Type (PRM_SET_DATA)	4-5		

6. Power on-----	6-1
6.1. Operation Mode -----	6-2
6.1.1. PROFIBUS Mode-----	6-2
6.1.2. Maintenance Mode-----	6-2
6.1.3. Switching Operation Mode -----	6-3
6.1.3.1. Switch PROFIBUS Mode to Maintenance Mode-----	6-3
6.1.3.2. Switch Maintenance Mode to PROFIBUS Mode-----	6-3
 7. Additional Function, Command and Alarm -----	 7-1
7.1. Additional Function -----	7-1
7.1.1. Override Function-----	7-1
7.2. Additional RS-232C Command-----	7-2
CP: Switch PROFIBUS /Maintenance Mode --	7-2
IO: Input / Output Monitor -----	7-3
OV: Override-----	7-4
7.2.1. Additional Parameter List -----	7-5
7.3. Additional Alarm -----	7-6
7.3.1. Fieldbus Error-----	7-6

1. Specifications

1.1. PROFIBUS Specifications

Table 1-1

Interface format	PROFIBUS – DP slave interface
Communication media	Special four wires twisted pair cable
Baud rate	Automatic detection (Maximum 12 Mbps)
Communication distance	100 m (12 Mbps) 200 m (1500 Kbps) 400 m (1500 Kbps) 1000 m (187.5 Kbps)
Network size	Up to 126 nodes
Data packets	Input: 10 bytes, Output: 10 bytes

1.2. Dimensions of Driver Unit

Table 1-1

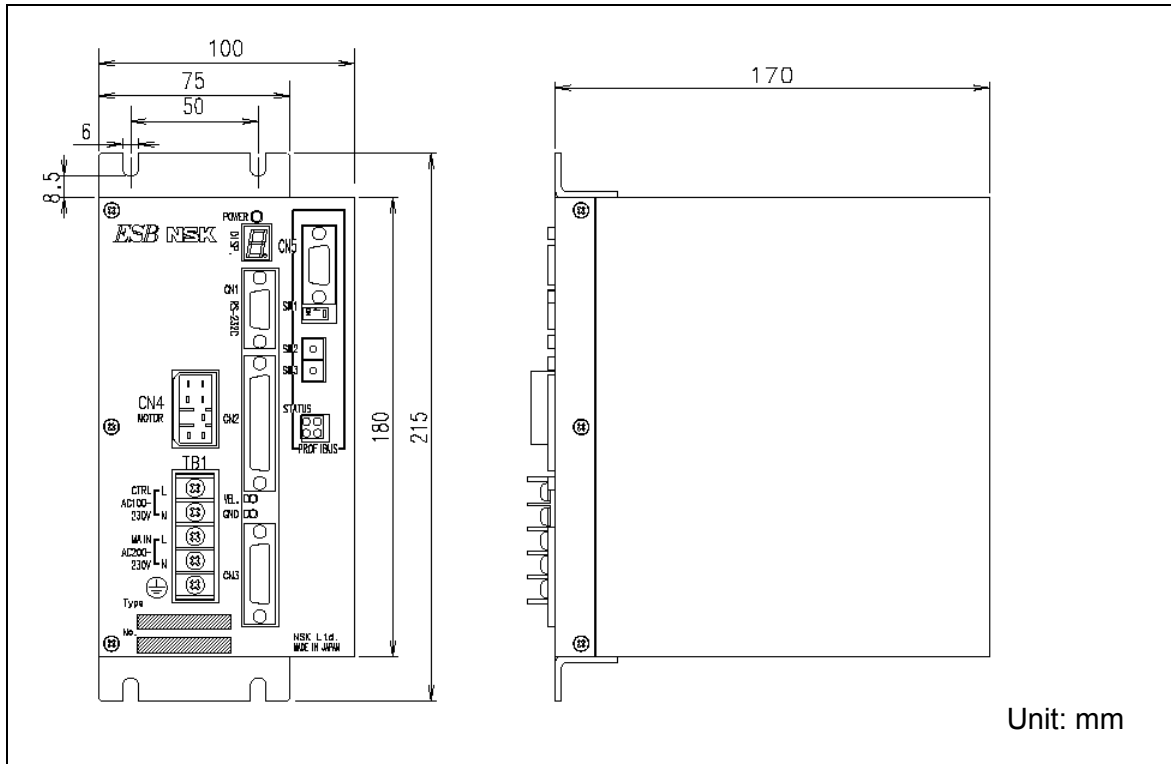

1.3. Specifications of Control Input and Output Signals

Table 1-2

Input signal	Control Input	CN2	When the operation mode is set to PROFIBUS: Emergency stop, Home position limit sensor and Over-travel limit switch (CW and CCW)
		PROFIBUS (CN5)	When the operation mode is set to the maintenance mode: Emergency stop, Servo on, Clear, Velocity loop integration OFF /Lower velocity gain, Clamp cancel* ¹ , Home Return start, Home position sensor, and Over-travel limit switch (CW and CCW)
Output signal	Control Output	Position feedback signal	Refer to “Resolution of Resolver” described in the “Megatorque Motor System User’s Manual” which is provided with the Driver Unit.
		CN2	Driver Unit ready, In-position, and Brake/ Brake control* ¹ .
		PROFIBUS (CN5)	When the operation mode is set to PROFIBUS: Driver Unit ready, Warning, In-position, Processing pulse generation, Brake/ Brake control* ¹ , Home position defined, Home Return completed/Home position detected, Velocity report, Operation program respond, Emergency stop state, Over-travel limit (CW and CCW), Home position sensor, Target proximity point A, Target proximity B.
			When the operation mode is set to the maintenance: Driver Unit ready, Warning, In-position, Processing pulse generation, Brake/ Brake control* ¹ , Home position defined, Home Return complete/Detect Home position, Velocity report, Emergency stop state, Over-travel limit (CW, CCW), Home position sensor, Target proximity A/Target proximity B.

*1: When using motor with brake combined with brake sequence function(BF1), signals Integrator off / Low gain will be used as Clamp cancel input, Brake output will be used as Brake control output.

- The switching command CP from the Handy Terminal specifies PROFIBUS mode or the maintenance mode. Refer to operational description of CP command for more details.
- PROFIBUS mode is to operate the Driver Unit in accordance with the control input signals from PROFIBUS.
- The maintenance mode is to operate tentatively the Driver Unit when PROFIBUS is not functioning for some reason.
- PROFIBUS mode is set to the initial setting after the Driver Unit is turned on.

1.4. Validity of Inputs and Outputs by Operation Mode

Validity of Input and Output of PROFIBUS and CN2 connector changes in accordance with the operation modes.

(Mode selection command CP switches the operation mode.)

1.4.1. Combination of Inputs and Outputs in PROFIBUS Mode and Maintenance Mode

Table 1-3

I/O	Signal code	PROFIBUS mode (Valid: ✓, Invalid: ✕)		Maintenance mode (Valid: ✓, Invalid: ✕)	
		PROFIBUS	CN2	PROFIBUS	CN2
Input	EMST	✓	✓	✕	✓
	SVON	✓	✕	✕	✓
	RUN	✓	—	✕	—
	STP	✓	—	✕	—
	CLR	✓	✕	✕	✓
	IOFF /CLCN ^{*1}	✓	✕	✕	✓
	HOS	✓	✕	✕	✓
	ORD	✓	—	✕	—
	PRG0	✓	—	✕	—
	PRG1	✓	—	✕	—
	PRG2	✓	—	✕	—
	PRG3	✓	—	✕	—
	PRG4	✓	—	✕	—
	PRG5	✓	—	✕	—
	JOG	✓	—	✕	—
	DIR	✓	—	—	—
	HLS	—	✓	—	✓
	OTP	—	✓	—	✓
	OTM	—	✓	✕	✓
Output	DRDY	✓	✓	✓	✓
	OVER	✓	—	✓	—
	IPOS	✓	✓	✓	✓
	BUSY	✓	—	✓	—
	BRK/BRKC ^{*1}	✓	✓	✓	✓
	HCMP	✓	—	✓	—
	HOME	✓	—	✓	—
	SPD	✓	—	✓	—
	ACK_PRG0	✓	—	✕	—
	ACK_PRG1	✓	—	✕	—
	ACK_PRG2	✓	—	✕	—
	ACK_PRG3	✓	—	✕	—
	ACK_PRG4	✓	—	✕	—
	ACK_PRG5	✓	—	✕	—
	EMSTA	✓	—	✓	—
	OTPA	✓	—	✓	—
	OTPM	✓	—	✓	—
	HLSA	✓	—	✓	—
	NEARA	✓	—	✓	—
	NEARB	✓	—	✓	—

*1: When using motor with brake combined with brake sequence function(BF1), signals Integrator off / Low gain will be used as Clamp cancel input, Brake output will be used as Brake control output.

(Blank Page)

2. Interface Specifications

2.1. CN2 Connector

2.1.1. CN2 Pin Out

Figure 2-1

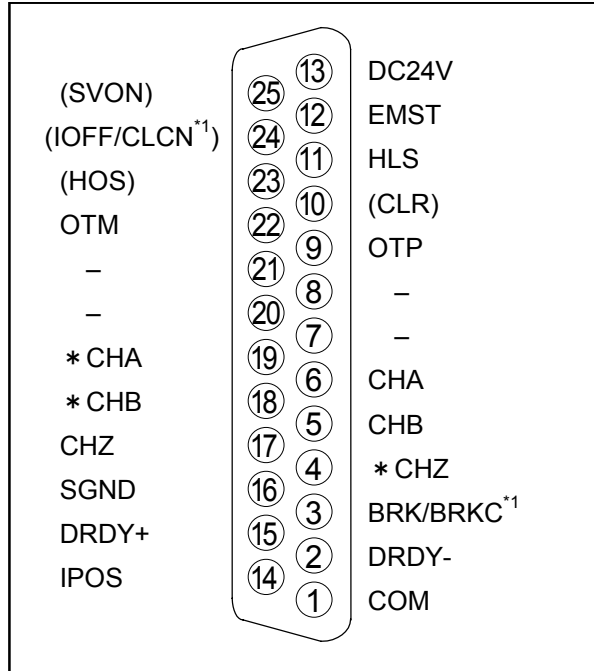

- Signals SVON, CLR, IOFF/CLCN*¹ and HOS, which are put in parentheses, are not valid in PROFIBUS mode.

*1: Signals parenthesized in the above figure (SVON, CLR, IOFF/CLCN*¹, and HOS) are not valid in PROFIBUS mode.

2.1.2. Signal Code and Function

Table 2-1

Pin No.	Signal code	I/O	Function
1	COM	O	Output COMMON
2	DRDY-	O	Driver Unit ready (-)
3	BRK/BRKC ^{*1}	O	Brake /Brake control signal (normally closed)
4	*CHZ ^{**1}	O	Position feedback signal *øZ / Digital position signal *MSB ^{*1}
5	CHB	O	Position feedback signal øB
6	CHA	O	Position feedback signal øA
7	-	-	Do not connect.
8	-	-	Do not connect.
9	OTP	I	Over-travel limit (+ direction: CW)
10	(CLR) ^{**2}	I	Clear input
11	HLS	I	Home position limit switch
12	EMST	I	Emergency stop
13	DC24	I	External power supply 24 VDC
14	IPOS	O	In-position
15	DRDY+	O	Driver Unit ready (+)
16	SGND	-	Signal ground
17	CHZ ^{*1}	O	Position feedback signal *øZ / Digital position signal *MSB ^{*1}
18	*CHB	O	Position feedback signal øB
19	*CHA	O	Position feedback signal øA
20	-	-	Do not connect.
21	-	-	Do not connect.
22	OTM	I	Over-travel limit (- direction: CCW)
23	(HOS) ^{**2}	I	Home Return start
24	(IOFF/CLCN ^{*3}) ^{*2}	I	Integrator OFF /Clamp cancel
25	(SVON) ^{**2}	I	Servo ON

*1: Parameter FZ (RS-232C communication) sets function of “Position feedback signal *øZ” and “Digital position signal *MSB.”

*2: Signals parenthesized in the above table (SVON, CLR, IOFF, and HOS) are not valid in PROFIBUS mode.

*3: When using motor with brake combined with brake sequence function(BF1), signals Integrator off / Low gain will be used as Clamp cancel input, Brake output will be used as Brake control output.

2.2. PROFIBUS-DP Interface

Figure 2-2

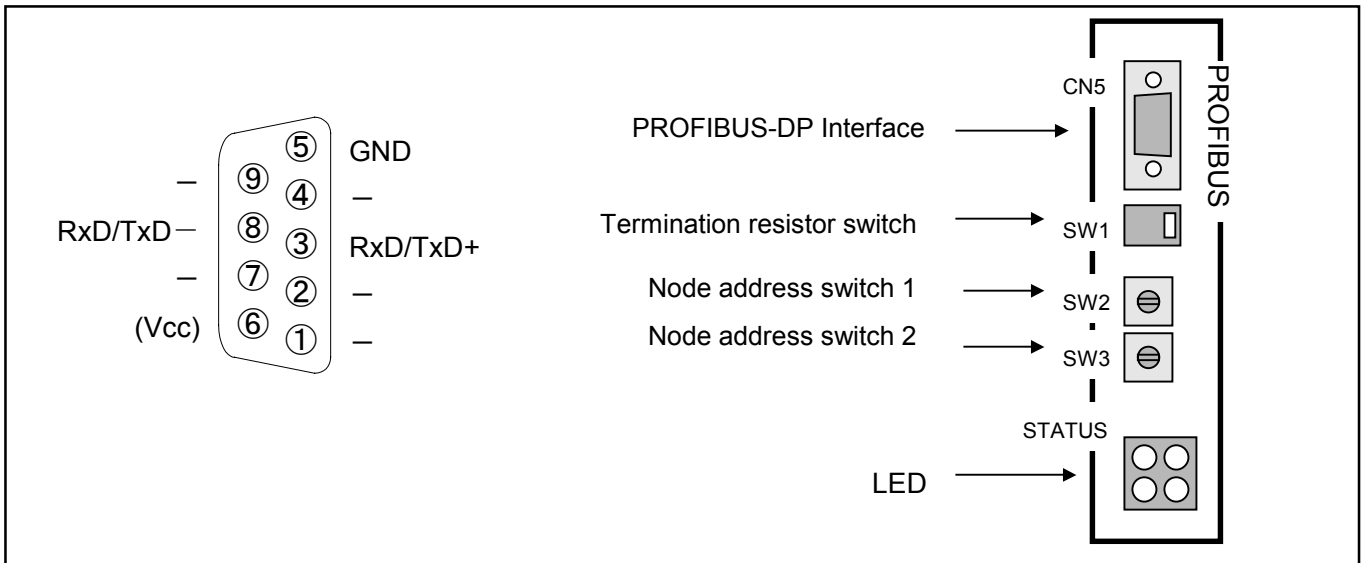

2.2.1. CN5 (PROFIBUS) Pin-Out

Table 2-2

Pin	Signal code	I/O	Function
1	—	---	Do not connect.
2	—	---	Do not connect.
3	RxD/TxD+	Input/Output	Signal (+)
4	—	---	Do not connect.
5	GND	---	Ground
6	(Vcc)	---	+5 VDC (For PROFIBUS)
7	—	---	Do not connect.
8	RxD/TxD-	Input/Output	Signal (-)
9	—	---	Do not connect.

- Voltage supply (Pin number 6) is for the external termination of network, which must be provided at the both ends of PROFIBUS. Refer to the specifications of PROFIBUS for the details of cable termination.

2.2.2. SW1: Termination Resistor Switch

Table 2-3

Switch setting	Function
Termination resistor switch ON	Termination resistor is effective.
Termination resistor switch OFF	Termination resistor is ineffective.

2.2.3. SW2 and SW3: Node Address Switch

- These switches are for setting node address in the range of 1 to 99. The switch SW1 sets the number of tens, while the SW2 switch sets the number of ones.

2.2.4. Indication of STATUS LED

Figure 2-3

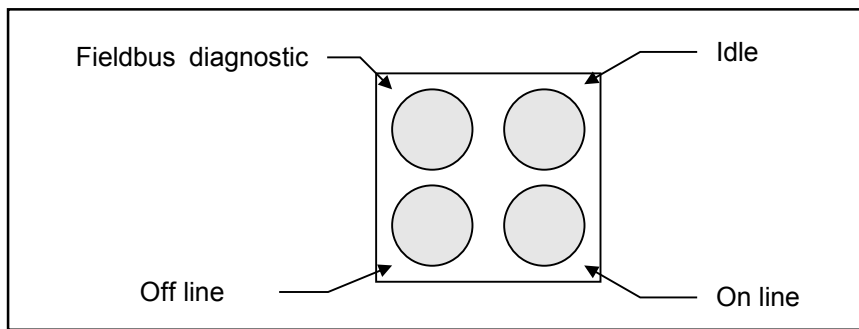

Table 2-4

Name	Color	Function
Diagnostic of fieldbus	Red	Indicates failure of the fieldbus. Blinking frequency identifies the details of failure. <ul style="list-style-type: none"> • Blinking at 1 Hz. An input or output configuration is not in the specified packet length (10 byte). • Blinking in 2 Hz There is an error on the user parameter. • Blinking in 4 Hz A problem has occurred at the moment of initialization of the PROFIBUS communication LSI.
Off-line	Red	Internal network module is off-line.
On-line	Green	Internal network module is on-line: thus enables communication.

3. Setting

- You need to set the following to operate the Driver Unit in your network.
 - ◇ Termination resistor
 - ◇ Node address
 - ◇ Configuration by GSD file
- The Driver Unit automatically detects and sets the communication speed. The Driver Unit supports the baud rates listed in the table below.

Table 3-1

Supporting baud rate
9.6 Kbit/s
19.2 Kbit/s
45.45 Kbit/s
93.75 Kbit/s
187.5 Kbit/s
500 Kbit/s
1.5 Mbit/s
3 Mbit/s
6 Mbit/s
12 Mbit/s

3.1. Termination Resistor

- When the Driver Unit is set to the top or the end of PROFIBUS network, set the termination resistor switch to ON. If you an external termination resistor, set the termination resistor switch to OFF.

3.2. Node Address

- Two rotary switches, SW2 and SW3, set the node address. Settable range of node address is 1 to 99. SW2 sets the number of tens and SW3 sets the number of ones. Thus, the relation between the node address and the settings of SW2 and SW3 switches can be numerically expressed as follows.

$$\text{Node address} = (\text{Setting of SW2} \times 10) + (\text{Setting of SW3} \times 1)$$

3.3. Configuration by GSD File

- A GSD file can be downloaded from web page of NSK.

(Blank Page)

4. Input and Output Specifications

4.1. Data Packets

Input : 10 bytes

Output : 10 bytes

4.2. I/O and Signal Format

Table 4- 1

Input (Master controller → Driver Unit)			Output (Driver Unit → Master controller)		
Byte	Bit	Function	Byte	Bit	Function
0	0	EMST (Emergency stop)	0	0	DRDY (Driver Unit ready)
	1	SVON (Servo ON)		1	OVER (Warning)
	2	RUN (Start Programmable Indexer)		2	IPOS (In position)
	3	STP (Decelerates to stop)		3	BUSY (Processing generated pulses)
	4	CLR (Clear)		4	BRK /BRKC ^{*1} (Brake /Brake control signal)
	5	IOFF /CLCN ^{*1} (Integration OFF /Clamp cancel)		5	HCMP (Home position defined)
	6	HOS (Home Return start)		6	HOME (Home Return completed)
	7	ORD (Override)		7	SPD (Velocity threshold)
1	0	PRG0 (Program channel 0)	1	0	ACK_PRG0 (Move/ Program channel 0)
	1	PRG1 (Program channel 1)		1	ACK_PRG1 (Move/ Program channel 1)
	2	PRG2 (Program channel 2)		2	ACK_PRG2 (Move/ Program channel 2)
	3	PRG3 (Program channel 3)		3	ACK_PRG3 (Move/ Program channel 3)
	4	PRG4 (Program channel 4)		4	ACK_PRG4 (Move/ Program channel 4)
	5	PRG5 (Program channel 5)		5	ACK_PRG5 (Move/ Program channel 5)
	6	(Reserved)		6	(Reserved)
	7	(Reserved)		7	(Reserved)
2	0	JOG (Jog start)	2	0	EMSTA (Emergency stop state)
	1	DIR (Jog direction)		1	OTPA (+ Over-travel limit state)
	2	(Reserved)		2	OTMA (- Over-travel limit state)
	3	(Reserved)		3	HLSA (Home position limit state)
	4	(Reserved)		4	NEARA (Target proximity/ In Target A)
	5	(Reserved)		5	NEARB (Target proximity/ In Target B)
	6	(Reserved)		6	(Reserved)
	7	(Reserved)		7	(Reserved)
3	0	(Reserved)	3	0	(Reserved)
	1	(Reserved)		1	(Reserved)
	2	(Reserved)		2	(Reserved)
	3	(Reserved)		3	(Reserved)
	4	(Reserved)		4	(Reserved)
	5	(Reserved)		5	(Reserved)
	6	PRM_REQ (Write/ read parameters)		6	PRM_ACK (Processing confirmed)
	7	PRM_OPE (Write/read selection)		7	PRM_STS (Data processed result)
4	–	PRM_SET_NO (Para. No.) (LSB)	4	–	PRM_GET_NO (Para. NO.) (LSB)
5	–	PRM_SET_NO (MSB)	5	–	PRM_GET_NO (MSB)
6	–	PRM_SET_DATA (Data) (LSB)	6	–	PRM_GET_DATA (Data) (LSB)
7	–	PRM_SET_DATA	7	–	PRM_GET_DATA
8	–	PRM_SET_DATA	8	–	PRM_GET_DATA
9	–	PRM_SET_DATA (MSB)	9	–	PRM_GET_DATA (MSB)

*1 : When using motor with brake combined with brake sequence function(BF1), signals Integrator off / Low gain will be used as Clamp cancel input, Brake output will be used as Brake control output.

4.3. Input Signal

4.3.1. Emergency Stop (EMST)

- The Driver Unit detects the input by its signal current level.
- The System disables the function of position loop control when the input of EMST is set to 1, and then the Motor stops in the state of servo lock in the velocity loop control.
- EMST input of CN2 connector is valid in PROFIBUS mode.

Table 4-2

EMST	Function
0	Clear Emergency Stop.
1	Emergency Stop

4.3.2. Servo ON (SVON)

- The input puts the Motor in Servo ON state.
- The Driver Unit detects the input by its current level.
- The Motor gets in Servo ON state when DRDY output is set to 1 after the power is on, then SVON input is set to 1.

Table 4-3

SVON	Function
0	Servo OFF
1	Servo ON

4.3.3. Start Programmable Indexer (RUN)

- This is to start a programmed operation of the specified channel in PRG0 - PRG5.
- The Driver Unit detects the rising edge(0 → 1) of input signal current.

4.3.4. Stop (STP)

- The Driver Unit detects the input by its current level.
- The Driver Unit stops the Motor when STP input is set to 1, and then disables the starting commands. You may set parameter MD for deceleration rate to stop the Motor.

Table 4-4

STP	Function
0	Starting commands valid.
1	Disables the starting commands.

4.3.5. Clear Position Error Counter / Alarm (CLR)

- The Driver Unit detects the input by the rising edge of signal current.
- The error counter is cleared when CLR input is set to 1. However, the error counter won't be cleared when the Motor is in the middle of operation caused by the following command.
 - ◇ Operation by positioning commands (AD, AR, ID, IR and HS)
 - ◇ Operation of Programmable Indexer (AD, AR, ID, IR, HS, JP and TI)
 - ◇ Home Return
 - ◇ Jog
- When the alarm of "Excessive position error" (F1) is reported, setting CLR input to 1 clears the error counter and the alarm.
- Alarms of "Software thermal (A3)," "Velocity error over (A4)," "Program error (A5)," "RS-232C error (C2)," and "Automatic tuning error (F8)" will be cleared when CLR input is set to 1.

4.3.6. Integration OFF / Lower Velocity Gain (IOFF) *When brake sequence function is invalid

- The Driver Unit detects the current level of input signal.
- When IOFF input is set to 1, the integration control is disabled, and the parameter VG for velocity loop proportional gain is lowered with the ratio set by the parameter LG for lowering velocity gain.
- Parameter IM:
When IOFF input is set to 1, parameter IM sets only one function to IOFF input such as "Integration OFF," or "Lowering velocity loop proportional gain."
- Lowering velocity gain is mainly used to control torque output when the Motor is holding its position with a brake.

Table 4-5

IOFF	Function
0	Integration ON• Lowering gain not available.
1	IM0: Integration OFF and Lowering gain (Shipping set) IM1: Integration OFF IM2: Lower velocity gain

4.3.7. Clamp cancel Input (CLCN) *When brake sequence function is valid

- Select brake clamp function valid or invalid.
- If CLCN input is 1, brake will be released, and no further brake clamp will be performed. However, if an alarm (which will make motor condition servo-off) occurs, brake will clamp.
- If CLCN input is 0, brake will clamp/unclamp depending on the motor motion command.

Table 4-6

CLCN	Function
0	Brake clamp function valid
1	Clamp cancel

4.3.8. Home Return Start (HOS)

- The input starts Home Return.
- The Driver Unit detects the rising edge(0 → 1) of signal current.

4.3.9. Override (ORD)

- The Driver Unit detects the current level of input signal.
- When ORD input is set to 1, the Motor operates under the velocity, which is obtained by application of parameter CV to the velocity set by parameters MV, HV, CV or JV.
- Normally ORD is set to 0. (Positioning velocity will follow the parameters MV, HV, CV and JV respectively.)
- Input of OVD in the middle of positioning will be invalidated.

Table 4-7

ORD	Function
0	Override OFF
1	Override ON

4.3.10. Internal Program Channel Select (PRGx: x = 0 to 5)

- This is to specify a number of internal program channels to be executed by RUN input.
- The channel number is specified by the binary codes of PRG0 to PRG5.

Table 4-8

CH No.	PRG5	PRG4	PRG3	PRG2	PRG1	PRG0
0	0	0	0	0	0	0
1	0	0	0	0	0	1
2	0	0	0	0	1	0
3	0	0	0	0	1	1
•	•	•	•	•	•	•
61	1	1	1	1	0	1
62	1	1	1	1	1	0
63	1	1	1	1	1	1

4.3.11. JOG

- Starts and stops Jog operation.
- The Driver Unit detects the rising edge of input signal current.

Table 4-9

JOG	Function
↑ (0 → 1)	JOG start (Starts and accelerates)
↓ (1 → 0)	JOG stop (decelerates and stops)

4.3.12. Direction (DIR)

- This input specifies the direction of operation.
- When the input is changed in the middle of Jogging, the Motor decelerates, and then reverses the rotational direction.

Table 4-10

DIR	Function
0	CW
1	CCW

4.3.13. Write/Read Parameter, Process Type (PRM_REQ/PRM_OPE)

- This input is to process (write or read out) parameters as specified by PRM_OPE input.
- The Driver Unit detects the rising edge of PRM_REQ input signal current.

Table 4-11

PRM_REQ	PRM_OPE	Function
0	0	No request
0	1	No request
0 → 1 (Rising edge detection)	0	Read out parameter settings
0 → 1 (Rising edge detection)	1	Copy parameter settings

4.3.14. Parameter Number (PRM_SET_NO)

- Specifies the parameter number that is an object of writing or reading out.
- Set the lower byte of parameter number to byte 4, and the higher one to byte 5.
- The parameter number shall be specified by a signed integer.

4.3.15. Writing Data Type (PRM_SET_DATA)

- This input specifies the type of parameter data, when requesting to write parameters.
- This input can be used as a parameter for an execution of command, or a start command of operation.
- Set the lowest byte of changed parameter data to byte 6, and the highest one to byte 9.
- A signed integer will specify a change of parameter data.

4.4. Output Signal

4.4.1. Driver Unit Ready (DRDY) / Warning (OVER)

- DRDY output is 1 (one) if the Driver Unit is ready to operate the Motor.
- State of DRDY / OVER outputs are shown in Table 4-12 when an alarm has been reported.

Table 4-12

Alarm	Setting	7-seg LED	DRDY Output	OVER Output	BRK Output	Motor state	Readout with TA command
Memory error ^{*1}	–	E0	0	0	0	Servo-off	E0>Memory Error
EEPROM error	–	E2	0	0	0	Servo-off	E2>EEPROM Error
System error ^{*2}	–	E7	–	–	–	Servo-off	E7>System Error
Interface error	–	E8	0	0	0	Servo-off	E8>I/F Error
Brake-on position error	–	F0	0	0	0	Servo-lock	F0>Clamp Position Error
Excess position error	EP1	F1	0	0	1	Servo-lock	F1>Excess Position Error
	EP2		1	1			
	EP3		0	1			
Software over travel limit	TO1	F2	0	0	1	Servo-lock	F2>Software Over Travel
	TO2		1	1			
Hardware over travel limit	HT0	F3	1	0	1	Servo-lock	F3>Hardware Over Travel
	HT1		0	0			
	HT2		1	1			
Emergency stop	–	F4	1	0	0	Servo-lock	F4>Emergency Stop
Program error	PE0	F5	1	0	1	Servo-lock	F5>Program Error
	PE1		1	1			
Automatic tuning error	AE0	F8	1	0	1	Normal	F8>AT Error
	AE2		1	1			
RS-232C error	SE0	C2	1	0	1	Normal	C2>RS232C Error
	SE1		0	0		Servo-lock	
	SE2		1	1		Normal	
CPU error	–	C3	0	0	0	Servo-off	(Cannot read out by TA)
Field bus error ^{*2}	–	C4	0	0	0	Servo-off	C4>Field bus Error
Resolver circuit error	–	A0	0	0	0	Servo-off	A0>Resolver Circuit Error
Absolute position error	–	A1	0	0	0	Servo-off	A1>Absolute Position Error
Software thermal sensor	–	A3	0	0	0	Servo-off	A3>Overload
Velocity error over (serious)	–	A4	0	1	0	Servo-off	A4>Velocity Abnormal
Velocity error over (minor)			1	1	1	Servo-lock	
Home position undefined	OU0	A5	1	0	1	Normal	A5>Origin Undefined
	OU2		1	1			
Brake error	–	A8	1	1	0	Servo-lock	A8>Brake Error
Heat sink overheat	–	P0	0	0	0	Servo-off	P0>Over Heat
Abnormal main AC line voltage	–	P1	0	0	0	Servo-off	P1>Main AC Line Trouble
Over current	–	P2	0	0	0	Servo-off	P2>Over Current
Control AC line under voltage	–	P3	0	0	0	Servo-off	P3>Control AC Line Under Voltage

*1. When this alarm occurred at the time of power-on, it won't be reported through PROFIBUS.

*2. This alarm won't be reported through PROFIBUS.

4.4.2. In-Position (IPOS)

- The following parameters are the conditions to output In-position signal.
 - FW : Fin Width (Sets the time length to keep outputting IPOS signal.)
 - IN : Criterion to detect completion of positioning.
 - IS : In-position stability timer (Sets time length for position error stability.)

4.4.3. Processing Pulse Generation (BUSY)

- This output notifies that the System is processing internal pulse train. The signal outputs 1 when executing following motion commands.
 - ◇ Operation by a positioning command (AD, AR, ID, IR and HS)
 - ◇ Programmable Indexer (AD, AR, ID, IR, HS, JP and TI)
 - ◇ Home Return
 - ◇ Jog
- This output does not change by overshooting of undershooting.

Table 4-13

BUSY	Function
0	No generation of internal pulses
1	Processing internally generated pulse

4.4.4. Brake Output (BRK) *When brake sequence function is invalid

- This specifies the timing to activate optional brake when the servo is off or EMST signal is inputted.

Table 4-14

BRK	Function
0	Clamp
1	Unclamp

4.4.5. Brake Control Output (BRKC) *When brake sequence function is valid

- Brake control signal to control brake clamp / un-clamp by the driver unit.
If BRKC output is 0, brake will clam. IF BRKC output is 1, brake will un-clamp.

4.4.6. Home Position Defined (HCMP)

- This is to notify that the Home position is set. When the power is on, HCMP output will be 1 simultaneously with DRDY output.
- HCMP output will be 0 when Home Return is interrupted in the middle of operation, or parameter DI (Direction inversion) setting is changed, even though the Home position has been set.

Table 4-15

HCMP	Function
0	Home position not set.
1	Home position is set.

4.4.7. Home Return Completed / Home Position Detected (HOME)

- This is to report completion of Home Return or the Motor is on the Home position.
- The following parameters set the way of report.

Figure 4-1: Parameters related to HOME output

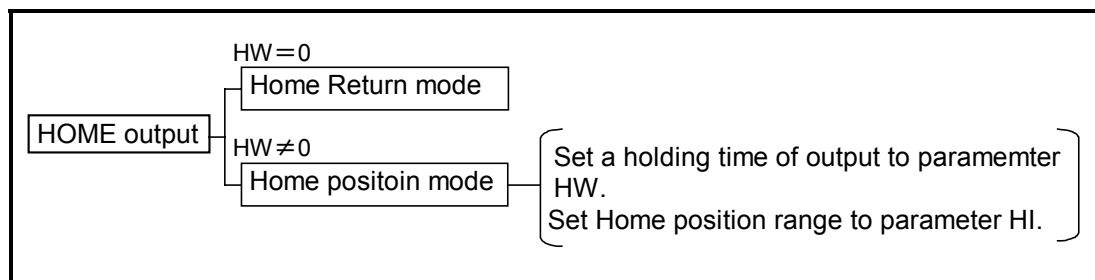

Table 4-16: Home Return mode (HW = 0)

HOME	Function
0	Home Return is not completed, or the Motor has moved from the Home position after completion of Home Return.
1	Home return is completed, and the Motor is on the Home position.

Table 4-17: HOME position mode (HW ≠ 0)

HOME	Function
0	Home position is not detected.
1	Home position is detected.

4.4.8. Velocity Report (SPD)

- This is to report the Motor velocity.
- The following parameters set the way of report and threshold to output signal.

Table 4-18: Parameters related to SPD output

Parameter	Function
SO	Sets velocity-detecting mode.
SB	Threshold to output SPD signal
ST	Sets stability timer to output SPD signal

Table 4-19: SPD Zero speed mode (SO0)

SPD	Function
0	Over the set speed
1	Under the set speed

Table 4-20: SPD Over speed mode (SO1)

SPD	Function
0	Under the set speed
1	Over or equal to the set speed

4.4.9. Move / Channel Acknowledge (ACK_PRG ×)

- Outputs the state of input for switching internal program channel before input of RUN command.
- Outputs a specified channel number while generating internal pulses after input of RUN command.
- In case of ‘&’ sequence, this signal outputs the specified channel number after input of RUN command.
- A binary number of ACK_PRG0 to ACK_PRG5 (6 bits) specifies the channel numbers.

Table 4-21:

CH No.	ACK_PRG5	ACK_PRG4	ACK_PRG3	ACK_PRG2	ACK_PRG1	ACK_PRG0
0	0	0	0	0	0	0
1	0	0	0	0	0	1
2	0	0	0	0	1	0
3	0	0	0	0	1	1
•	•	•	•	•	•	•
61	1	1	1	1	0	1
62	1	1	1	1	1	0
63	1	1	1	1	1	1

Figure 4-2: Signal timing of program operation

(An example shown below is to start the channel number 5.)

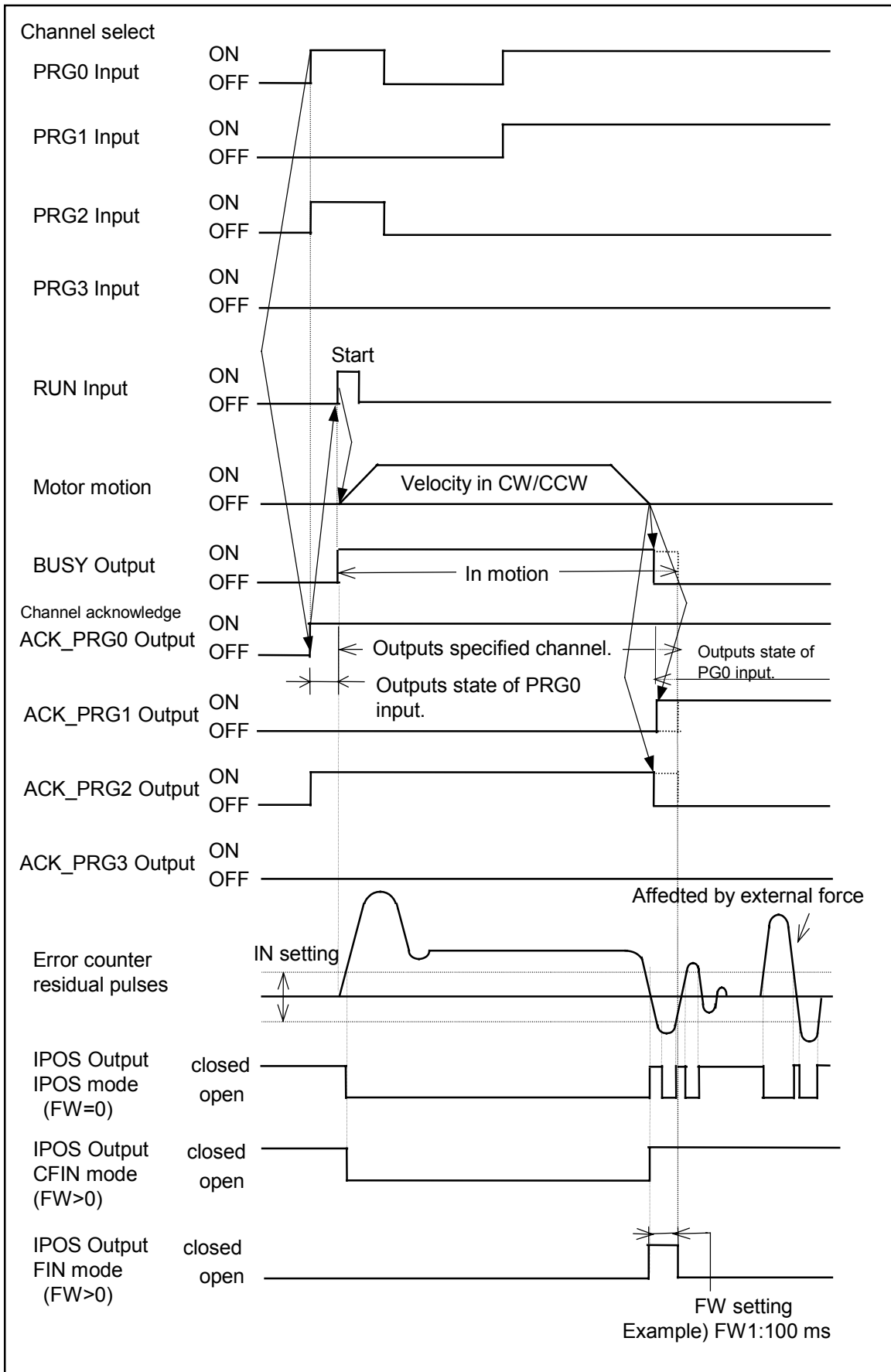

4.4.10. Emergency Stop State (EMSTA)

- This is to inform the state of Emergency stop.
- This output is a logic sum of EMST of CN2 control input and PROFIBUS control input.

Table 4-22:

EMSTA	Function
0	Clear emergency stop
1	Emergency stop

4.4.11. State of Over- travel Limit (OtxA)

- This output reports the state of over-travel limits.
- This output is a logic sum of OTx of CN2 control input and software over-travel limit.

Table 4-23:

OtxA	Function
0	Travel limit is not detected.
1	Travel limit is detected.

4.4.12. State of Home Position Limit Sensor (HLSA)

- This output reports state of Home position limit sensor (HLS of CN2 control input).

Table 4-24:

HLSA	Function
0	Home position sensor is not detected.
1	Home position sensor is detected.

4.4.13. Target Proximity / In Target (NEARA, NEARB)

- This output reports that the Motor is nearing the target position, or the Motor is in a specified target zone.
- The following parameters set the type of report.
- Refer to “7.1.14. Target Proximity / In Target” of ESB User’s Manual.

Figure 4-3: Related parameters to NEAR output

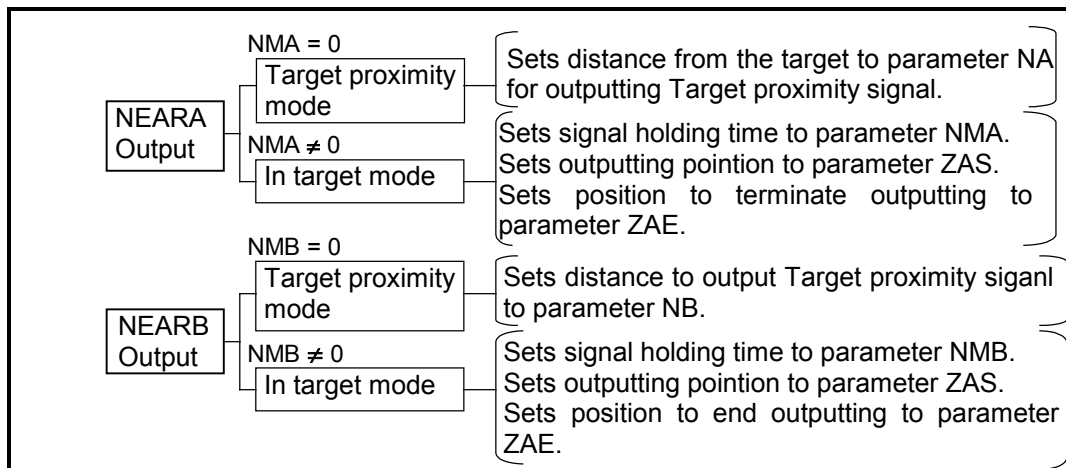

Table 4-25: NEARx: Target proximity (NMx = 0)

NEARx	Function
0	Not nearing target position.
1	Nearing target position.

Table 4-26: NEARx: In Target (NMx ≠ 0)

NEARx	Function
0	Not in target zone.
1	In target zone.

4.4.14. Processing Confirmed / Data Processed Result (PRM_ACK / PRM_STS)

- This output reports the end of processing and the processed result as the response to the commands of Write / Read parameters.
- PRM_ACK reports completion or incompleteness of parameter processing, while PRM_STS reports the result of the processing (success/fail).

Table 4-27:

PRM_ACK	PRM_STS	Function
0	0	Idle or processing data as instructed.
0	1	Idle or processing data as instructed.
1	0	Processing completed (Failed)
1	1	Processing completed (Successful)

4.4.15. Parameter Number (PRM_GET_NO)

- This is to report the parameter number that is the objective for reading out or writing data.
- The lower byte of the parameter number shall be set to byte 4, and the higher one to byte 5.
- A signed integer will report a parameter number.

4.4.16. Parameter Contents (PRM_GET_DATA)

- When reading out parameters is requested, this signal outputs the contents of read-out parameter.
- When reading out of parameter is requested, this signal outputs copies of PRM_SET_DATA.
- Set byte 6 to the lowest byte of the parameter contents, and byte 9 to the highest byte.
- The contents of parameter will be reported in a signed integer.

(Blank Page)

5. Command Interface

5.1. Outline of Command

- We classify all commands by attribute of Read / Write and function as shown in Table 5-1.
- Refer to “5.2. Parameter Interface” for parameter, command and way of using monitor.
- Program commands are the same attribute as the parameters, but they differ from the parameters in way of use. Refer to “5.3. Program Interface.”

Table 5-1

Command (attribute)	Command number	Classification
Parameter (Read/Write)	001 – 019	Servo parameters (1)
	020 – 039	Servo parameters (2)
	040 – 059	Related to servo state output
	060 – 079	Related to pulse train input operation
	080 – 099	Related to position feedback signal
	100 – 119	Related to position scale
	120 – 139	Related to velocity
	140 – 159	Related to Home Return
	160 – 179	Characteristic of Motor
	180 – 199	Related to I/O
	200 – 219	Related to processing parameter
	220 – 239	Related to automatic tuning
	240 – 259	Special functions
	260 – 279	Related to outputs for expanded function
280 – 299	Related to warning	
Command (Write)	300 – 319	Adjusting
	320 – 339	Processing parameter
Operation (Write)	400 – 419	Positioning
	420 – 439	Home Return
Program editing (Write)	500 – 519	Editing internal program
	600 – 619	Positioning
	620 – 639	Home Return
	640 – 659	Control command
	660 – 679	Optional code
Monitor (Read out)	800 – 819	Alarm
	820 – 839	Read out internal program
	840 – 859	Various monitors

5.2. Parameter Interface

- The following procedures make possible to read or write parameters, to execute a command, to start an operation, and to monitor current status.

5.2.1. Procedures for Writing Parameter, Executing Command and Starting Operation

Figure 5-1: Handshake example: Writing parameter, executing command and starting operation

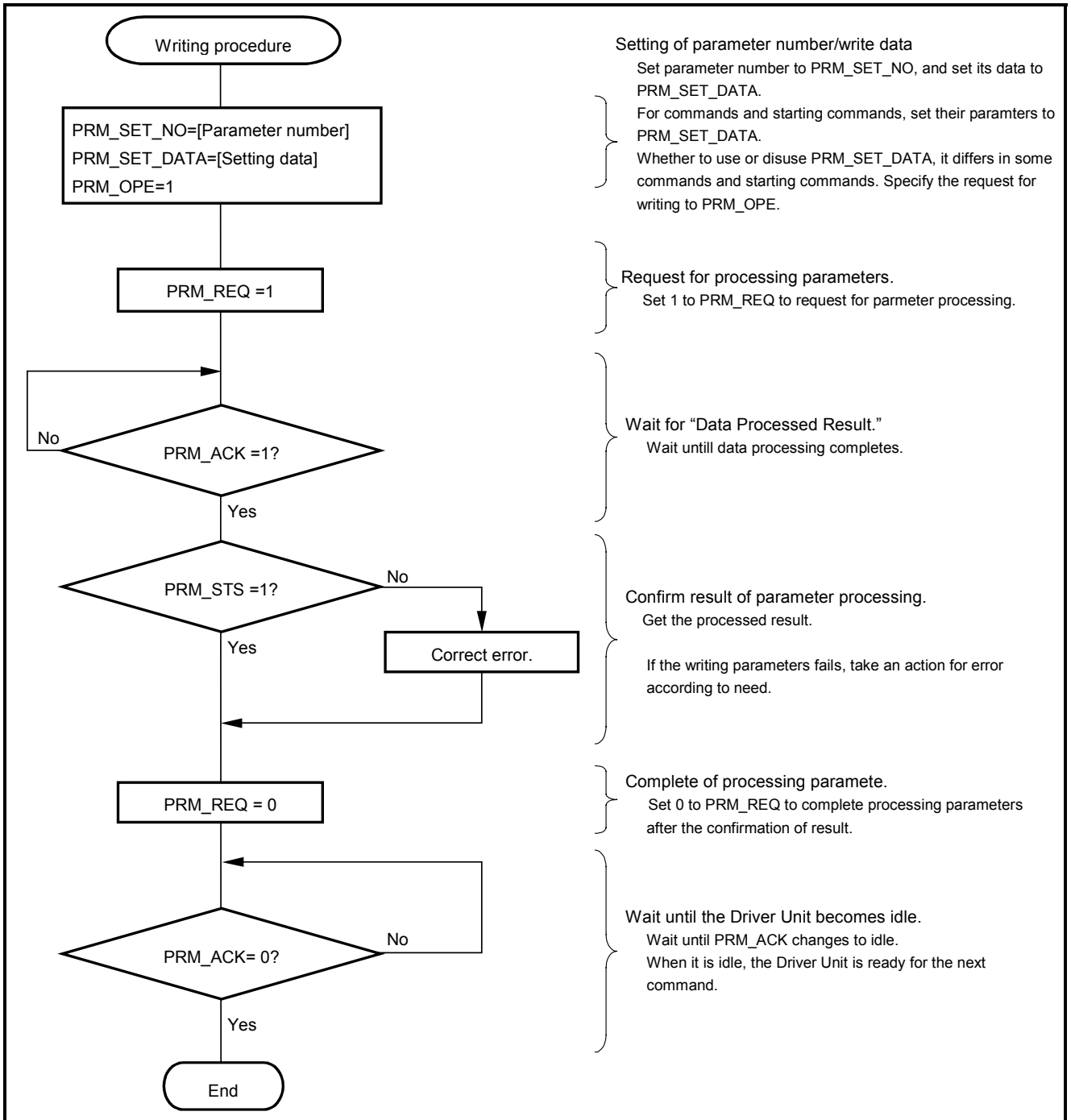

5.2.2. Procedures for Reading out Parameters / Monitoring Operating Conditions

Figure 5-2: Handshake example: Parameter read out and monitoring

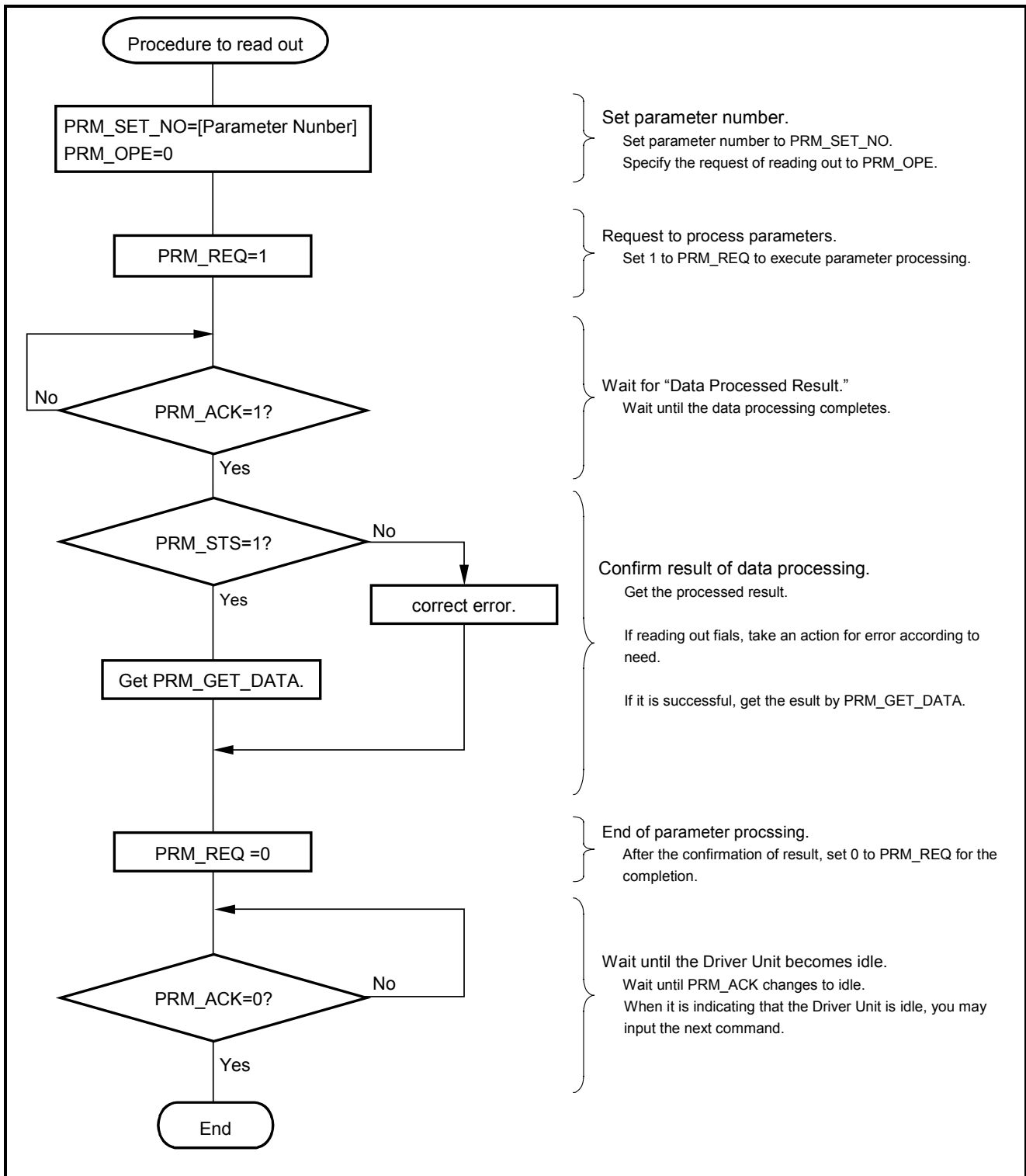

5.3. Program Interface

- Use of the program interface enables to edit and read out the internal programs. The program interface consists of a number of command interfaces.

5.3.1. Procedure for Editing Internal Program

Figure 5-3: Handshake example: Editing internal program

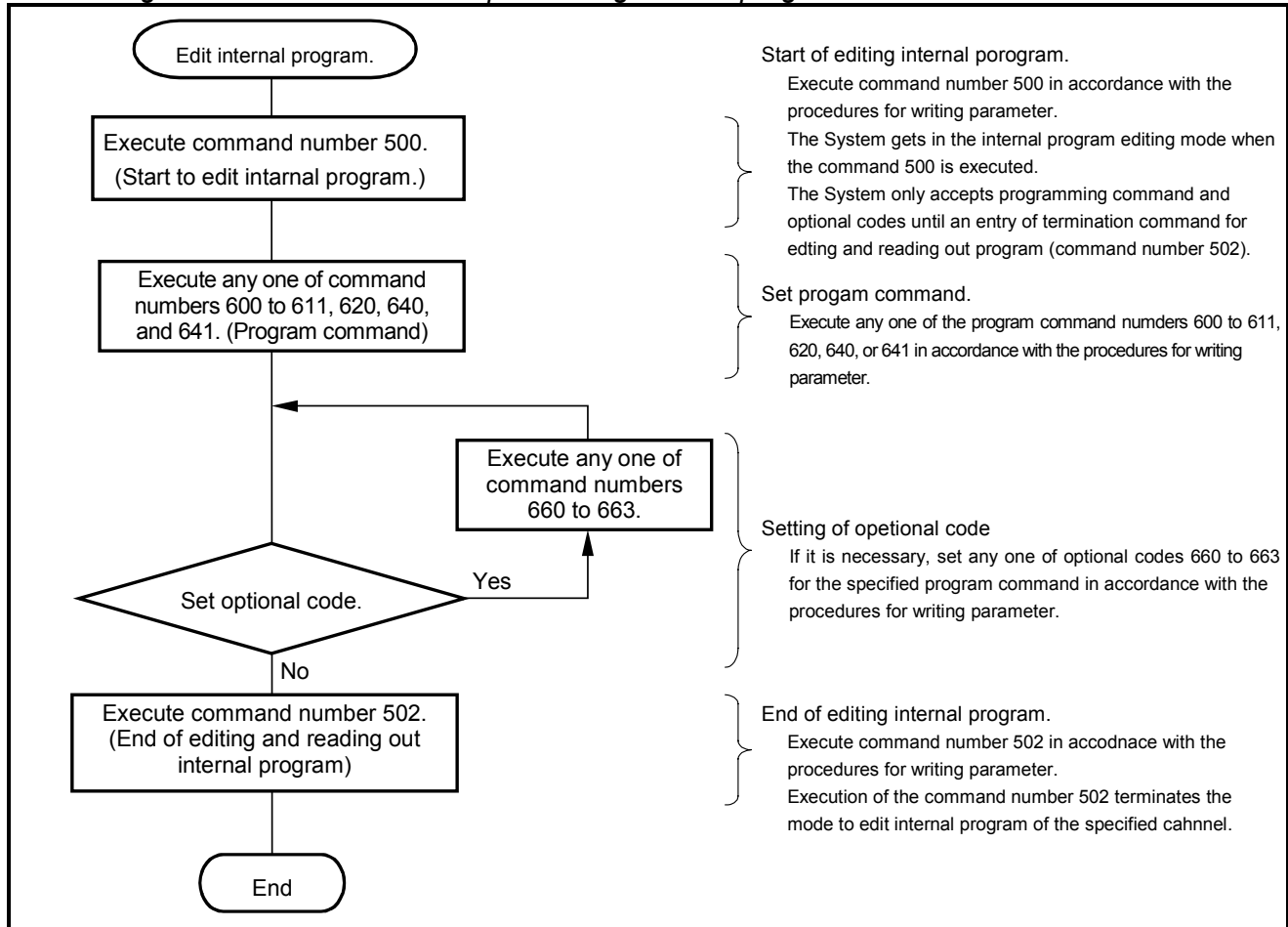

- The table below shows the combinations of available program commands and optional codes.

Table 5-2: Combination of program commands and optional codes

Command	Optional code	660	661	662	663
		–	OE n	CV n	CA n
600 (AD), 601 (AD/PL), 602 (AD/MI), 603 (AD / EX)		N/A	✓	✓	✓
604 (AR), 605 (AR/PL), 606 (AR/MI), 607 (AR/EX)		N/A	✓	✓	✓
608 (ID), 609 (ID/EX)		✓	✓	✓	✓
610 (IR), 611 (IR/EX)		✓	✓	✓	✓
620 (HS)		N/A	✓	N/A	N/A
640 (JP)		N/A	N/A	N/A	N/A
641 (TI)		N/A	N/A	N/A	N/A

5.3.2. Procedure for Reading out Internal Program

Figure 5-4: Example of handshake: Reading out internal parameter

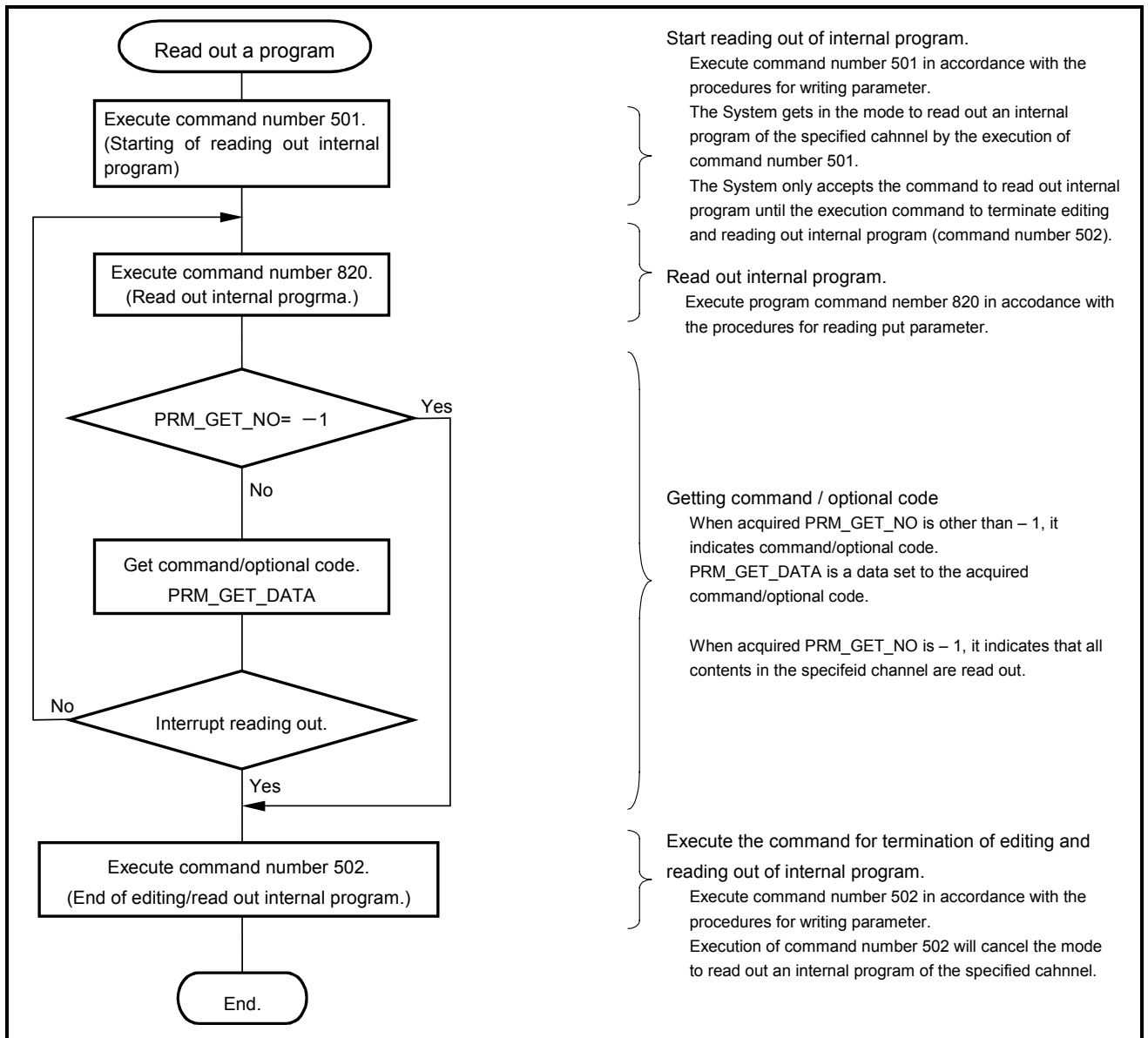

5.4. Command List

- The parameters marked with ★ of the column of “Correspondence” in the lists below require to lift the protection by inputting “/NSK ON” when setting them via RS-232C. It does not require lifting the protection for setting them through PROFIBUS.
- Refer to “5.4.7. Processing Decimal Place” for the decimal place in the command lists.

5.4.1. Parameter

Table 5-3: Parameter List

Parameter	Correspondence	Function	Initial setting	Data range	Unit	Decimal place
1	PG	Position gain	0.100	0.010 – 1.000	–	3
2	VG	Velocity gain	1.0	0.1 – 255.0	–	1
3	VGL	Velocity gain, lower	1.0	0.1 – 255.0	–	1
4	VI	Velocity integrator frequency	1.00	0.10 – 63.00	Hz	2
5	VIL	Velocity integrator gain, lower	1.00	0.10 – 63.00	Hz	2
6	★VM	Velocity integrator mode	1	0: No integration 1: Integration available	–	0
7	LG	Lower gain	50	0 – 100	%	0
8	★TL	Torque limit rate	100	0 – 100	%	0
9	★GP	Gain switching point	0	0 : No gain switching 1 – 1 000	pulse	0
10	GT	Switching gain timer	5	0 – 1 000	ms	0
11–19	–	Reserved	–	–	–	–
20	FO	Low-pass filter, off velocity	0.00	0: Switching off 0.01 – 3.00	s ⁻¹	2
21	FP	Low-pass filter, primary	0	0: Filter OFF 10 – 500	Hz	0
22	FS	Low-pass filter, secondary	0	0: Filter OFF 10 – 500	Hz	0
23	NP	Notch filter, primary	0	0: Filter OFF 10 – 500	Hz	0
24	NS	Notch filter, secondary	0	0: Filter OFF 10 – 500	Hz	0
25	NQ	Notch filter, Q parameter	0.25	0.10 – 5.00	Hz	2
26	★DBP	Dead band	0	0 – 4095	pulse	0
27	★ILV	Integration limit	100.0	0.0 – 100.0	%	1
28	★FF	Feed forward gain	0.0000	0.0000 – 1.0000	–	4
29	★FC	Friction	0	0 – 2047	–	0
30–39	–	(Reserved)	–	–	–	–
40	CO	Position error counter over limit	50 000	1 – 99 999 999	pulse	0
41	IN	In-position	100	0 – 99 999 999	pulse	0
42	IS	In-position stability counter	0.0	0, 0.3 – 100.0	100 ms	1
43	FW	In-position FIN width	1.0	0.0: COIN mode + 0.3– +100.0:FIN mode - 0.3– -100.0:CFIN mode	– 100 ms -100 ms	1
44	★VO	Velocity error over limit	2730	1 – 5461	3.000/ 5461 s ⁻¹	0
45	★VW	Velocity error over limit width	100	0 – 1 000	ms	0
46	★OR	Criterion, overrun alarm	409 600	204 800 – 819 200	pulse	0
47–49	–	Reserved	–	–	–	–
50	★CE	Brake-on position error	1000	1 – 99 999 999	pulse	0
51–61	–	Reserved	–	–	–	–
62	★RR	Resolver resolution	– 3	-3: High/low switching 1:Fixed to low resolution	–	0
63–79	–	(Reserved)	–	–	–	–

Table 5-4: Parameter list (Continued [1])

Parameter	Correspondence	Function	Initial setting	Data range	Unit	Decimal place
80	FD	Position feedback signal phase.	0	0: Leading phase A in CW. 1: Leading phase B in CW.	–	0
81	★FZ	Position feedback signal Z/MSB	0	0: øZ output 1: MSB output	–	0
82	★FR	Resolution: Position feedback signal	1	1: 12bit resolution	–	0
83 – 99	–	(Reserved)	–	–	–	–
100	★PS	Position scale select	1	1	rev	0
101	★DI	Direction inversion	0	0: CW is (+). 1: CCW is (-).	–	0
102	★OTP	Over travel limit position	0	0 – ± 99 999 999	pulse	0
103	★OTM	Over travel limit position	0	0 – ± 99 999 999	pulse	0
104	★AO	Absolute position scale offset	0	0 – 819 199	pulse	0
105–119	–	(Reserved)	–	–	–	–
120	MV	Move velocity	1.0000	0.0001 – 3.0000	s ⁻¹	4
121	MA	Move acceleration	1.00	0.01 – 1 280.00	s ⁻²	2
122	JV	JOG velocity	0.1000	0.0001 – 3.0000	s ⁻¹	4
123	JA	JOG acceleration	1.00	0.01 – 1 280.00	s ⁻²	2
124	HV	Home return velocity	0.2000	0.0001 – 3.0000	s ⁻¹	4
125	HA	Home return acceleration	1.00	0.01 – 1 280.00	s ⁻²	2
126	HZ	Home return near-zero speed	0.0100	0.0001 – 0.2000	s ⁻¹	4
127	MD	Move deceleration	0	0: Stop immediately. 0.01 – 1 280.00	s ⁻²	2
128–130	–	(Reserved)	–	–	–	–
131	OV	Velocity change ration	100	0 – 200	%	0
132–139	–	(Reserved)	–	–	–	–
140	★OS	Origin setting mode	4	1, 3, 4, 5: Standard homing. 6: Home position by teaching	–	0
141	★PH	Program Home Return	0	0: Automatic homing invalid 1: Each programmed operation (when Home position is not set.) 2: Each RUN input.	–	0
142	★HD	Home Return direction	1	0: (+) direction 1: (-) direction	–	0
143	★HO	Home offset	0	0 – ± 802 816	pulse	0
144–159	–	(Reserved)	–	–	–	–
160	★PA	Phase adjust	700	24 – 1 048	–	0
161	★OL	Overload limit ^{*1}	–	0 – 100	–	0
162	★RC	Rated current	–	0 – 100	%	0
163	★LR	Low torque ripple	0	0: Standard 1: Low torque ripple	–	0
164	★RO	ABS/INC resolver set position offset	2 048	0 – 4 095	–	0
165–179	–	(Reserved)	–	–	–	–
180	★AB	I/O polarity	00h	0000 0000b – 0101 0011b	–	0
181	★NW	Chattering preventive timer	0	0 – 4	2.8 ms	0
182	★IM	IOFF mode	0	0: Integration OFF and lower gain. 1: Integration OFF 2: Lower gain	–	0
183–189	–	(Reserved)	–	–	–	–
190	★BF	Brake sequence function	0	0, 1	–	0
191	★WC	Brake-on timer	*1	*1 – 30.0	100 ms	0
192	★WU	Brake-off timer	*1	*1 – 30.0	100 ms	0
193–199	–	(Reserved)	–	–	–	–

*1: Initial setting differs with Motor size.

Table 5-5: Parameter List (Continued [2])

Parameter	Correspondence	Function	Initial setting	Data range	Unit	Decimal place
200	★WM	Write mode to EEPROM	0	0: Backup 1: No backup	—	0
201–219	—	(Reserved)	—	—	—	—
220	★LO	Load inertia	0	0.000 – 50.000	kgm ²	3
221	SG	Servo gain	0	0 – 30	Hz	0
222–239	—	(Reserved)	—	—	—	—
240	★SL	Control mode	3	1: Torque control 2: Velocity control 3: Position control	—	0
241	AL	Acceleration limiter	0	0: Function disabled. 0.01 – 1 280.00	s ⁻²	2
242–259	—	(Reserved)	—	—	—	—
260	HW	Home signal holding time	0.0	0, 0.3 – 100.0	100 ms	1
261	HI	Home In-position	0	0 – 102 400	pulse	0
262	★SO	SPD output mode	0	0: Zero speed mode 1: Over speed mode	—	0
263	SB	Criterion, SPD signal output	0.00	0.00 – 3.00	s ⁻¹	2
264	ST	Speed stability timer	0.0	0, 0.3 – 100.0	100 ms	1
265	★NMA	Near A/Near position A output mode	0.0	0.0: Proximity mode 0.3 – 100.0: Area mode	— 100 ms	1
266	★NMB	Near B/Near position B output mode	0.0	0.0: Proximity mode. 0.3 – 100.0: Area mode	— 100 ms	1
267	NA	Near position A	100	1 –99 999 999	pulse	0
268	NB	Near position B	100	1 – 99 999 999	pulse	0
269	ZAS	Start point of zone A	0	0 – ± 99 999 999	pulse	0
270	ZAE	Endpoint of zone A	0	0 – ±99 999 999	pulse	0
271	ZBS	Start point of zone B	0	0 – ±99 999 999	pulse	0
272	ZBE	Endpoint of zone B	0	0 – ±99 999 999	pulse	0
273–279	—	(Reserved)	—	—	—	—
280	★OU	Origin Undefined	0	0: DRDY/OVER No change 2: OVER output closed	—	0
281	★EP	Excessive position error , Alarm type	2	1: DRDY output open. 2 : OVER output closed. 3 : DRDY: Open OVER: Closed	—	0
282	★TO	Software travel limit over, Alarm type	2	1 : DRD: open 2 : OVER: closed	—	0
283	★HT	Hardware travel limit over, Alarm type	2	0 : DRDY/OVER No change. 1: DRDY: Open 2: OVER: Closed	—	0
284	★PE	Program error, Alarm type	2	0: DRDY/OVER No change 2: OVER: Closed	—	0
285	★AE	Automatic tuning error, Alarm type	2	0 : DRDY/OVER No change 2 : OVER: Closed	—	0
286–299	—	(Reserved)	—	—	—	—

5.4.2. Managing Command

Table 5-6

Command	Correspondence	Function	Data range	Unit	Decimal place
300	AZ	Absolute zero position set	—	—	—
301	AT	Automatic tuning	—	—	—
302	★OG	Origin set (Resolver phase adjust)	—	—	—
303–319	—	(Reserved)	—	—	—
320	★SI	System initialization	0: Servo parameters 1: All parameters 2: All parameters excluding PA and RO) 3: All parameters (PA700)	—	0
321	★WD	Write data to EEPROM	—	—	—
322–329	—	(Reserved)	—	—	—
330	★KB	Kill Brake	1,0	—	0
331–339	—	(Reserved)	—	—	—

5.4.3. Operation Command

Table 5-7

Command	Correspondence	Function	Data range	Unit	Decimal place
400	AD	Absolute positioning, Degree (Short cut)	0 – 35 999	0.01°	0
401	AD/PL	Absolute positioning, Degree (CW)	0 – 35 999	0.01°	0
402	AD/MI	Absolute positioning, Degree (CCW)	0 – 35 999	0.01°	0
403	AD/EX	Absolute positioning, Degree (DIR input)	0 – 35 999	0.01°	0
404	AR	Absolute positioning, Resolver (Short cut)	0 – 819 199	pulse	0
405	AR/PL	Absolute positioning, Resolver (CW)	0 – 819 199	pulse	0
406	AR/MI	Absolute positioning, Resolver (CCW)	0 – 819 199	pulse	0
407	AR/EX	Absolute positioning, Resolver (DIR input)	0 – 819 199	pulse	0
408	ID	Incremental positioning, Degree	0 – ±9 999 999	pulse	0
409	ID/EX	Incremental positioning, Degree (DIR input)	0 – ± 9 999 999	pulse	0
410	IR	Incremental positioning,, Resolver	0 – ±99 999 999	pulse	0
411	IR/EX	Incremental positioning, Resolver (DIR input)	0 – 99 999 999	pulse	0
412	SP	Start program	0 – 63	—	0
413–419	—	(Reserved)	—	—	—
420	HS	Home Return start	—	—	0
421–439	—	(Reserved)	—	—	—
440	DC	Digital RS-232C command	Velocity control: 0 – ± 5461 Torque control: 0 – ± 4095	$\frac{3.0000}{5461} S^{-1}$ $\frac{100}{4095} \%$	0
441–459	—	(Reserved)	—	—	—

5.4.4. Editing Program

Table 5-8

Command	Correspondence	Function	Data range	Unit	Decimal place
500	CH	Channel select	0 – 63	–	0
501	TC	Tell channel program	0 – 63	–	0
502	–	End of reading out or editing channel program.	–	–	–
503	CC	Clear channel	0 – 63	–	0
504–519	–	(Reserved)	–	–	–

5.4.5. Program Command

Table 5-9

Command	Correspondence	Function	Data range	Unit	Decimal place
600	AD	Absolute positioning, Degree (Short cut)	0 – 35 999	0.01°	0
601	AD/PL	Absolute positioning, Degree (CW)	0 – 35 999	0.01°	0
602	AD/MI	Absolute positioning, Degree (CCW)	0 – 35 999	0.01°	0
603	AD/EX	Absolute positioning, Degree (DIR input)	0 – 35 999	0.01°	0
604	AR	Absolute positioning, Resolver (Short cut)	0 – 819 199	pulse	0
605	AR/PL	Absolute positioning, Resolver (CW)	0 – 819 199	pulse	0
606	AR/MI	Absolute positioning, Resolver (CCW)	0 – 819 199	pulse	0
607	AR/EX	Absolute positioning, Resolver (DIR input)	0 – 819 199	pulse	0
608	ID	Incremental positioning, Degree	0 – ± 9 999 999	pulse	0
609	ID/EX	Incremental positioning, Degree (DIR input)	0 – ± 9 999 999	pulse	0
610	IR	Incremental positioning, Resolver	0 – ± 99 999 999	pulse	0
611	IR/EX	Incremental positioning, Resolver (DIR input)	0 – 99 999 999	pulse	0
612–619	–	(Reserved)	–	–	–
620	HS	Home Return start	–	–	0
621–639	–	(Reserved)	–	–	–
640	JP	Jump	0 – 63	–	0
641	TI	Timer	0.3 – 100.0	100 ms	1
642–659	–	(Reserved)	–	–	–
660	–	Division of indexing points	0: Delete 2 –99	–	0
661	OE	Sequence option edit	0: Delete 1: * Execute next command : 2 &: Wait for for RU input .	–	0
662	CV	Channel velocity	0: Delete 0.0001 – 3.0000	s ⁻¹	4
663	CA	Channel acceleration	0: Delete 0.01–3.0000	s ⁻²	2
664–679	–	(Reserved)	–	–	–

5.4.6. Monitor

Table 5-10

Command	Correspondence	Function	Data range	Unit	Places of decimal
800	TA	Alarm	Each bit indicates alarm. Byte number 3 2 1 0 Alarm P7 – P0 A7 – A0 C7 – C0 F7 – F0	–	0
801–819	–	(Reserved)	–	–	–
820	–	Internal program			0
821–839	–	(Reserved)	–	–	–
840	IO0	Input/Output state	Indicates Input/Output of CN2 connector. Bit 11 10 9 8 7 6 5 4 3 2 1 0 Function SVON EMST IOFF HLS HOS CLR OTM OTP DRDY BRK IPOS HOME	–	0

Table 5-11: Monitor (Continued [1])

841	IO1	Input/Output state (2)	<p>Parameter AB is set to the inputs of CN2, and then the result that are merged with PROFIBUS control inputs will be shown.</p> <p>Bit 11 10 9 8 7 6 5 4 3 2 1 0</p> <p>Function SVON EMST IOFF HLS HOS CLR OTM OTP DRDY BRK IPOS HOME</p>	-	0
842	IO2	Input/Output state (3)	<p>Indicates control Inputs/Outputs of PROFIBUS.</p> <p>Bit 12 11 10 9 8 7 6 5 4 3 2 1 0</p> <p>Function PRG5 PRG4 PRG3 PRG2 PRG1 PRG0 RUN STP 0 0 IPOS NEARA NEARB</p>	-	0

Table 5-12: Monitor (Continued [2])

843	IO3	Input/Output state (4)	<p>Indicates control Inputs/Outputs of PROFIBUS.</p> <p>Bit 12 11 10 9 8 7 6 5 4 3 2 1</p> <p>0 Function JOG DIR RUN HOS STP 0 ORD DRDY OVER IPOS SPD HOME HCMP</p>	-	0
844	IO4	Input/Output state (5)	<p>Indicates control Input/Output of PROFIBUS</p> <p>Bit 16 15 14 13 12 11 10 9 8 7 6 5 4 3 2 1 0</p> <p>Function EMST SVON RUN STP CLR IOFF HOS ORD JOG DRDY OVER IPOS BUSY BRK HCMP HOME SPD</p>	-	0

Table 5-13: Monitor (Continued [3])

845	IO5	Input/Output state (6)	Indicates control Inputs/Outputs of PROFIBUS.		0
			Bit 16 15 14 13 12 11 10 9 8 7 6 5 4 3 2 1 0	Function PRG5 PRG4 PRG3 PRG2 PRG1 PRG0 RUN ACK_PRG5 ACK_PRG4 ACK_PRG3 ACK_PRG3 ACK_PRG 2 ACK_PRG1 ACK_PRG0 IPOS BUSY NEARA NEARB	
846	TE	Tell position error counter	0 – ± 99 999 999	pulse	0
847	TP	Tell position (In unit of pulse)	0 – 819 199	pulse	0
848	TP	Tell position (In unit of degree)	0 – 35 999	0.01°	0
849	TR	Tell RDC position data	0 – 16 383	pulse	0
850	TT	Tell torque and thermal	0.0 – 1 00.0	%	1
851–859	–	(Reserved)	–	–	–

5.4.7. Processing Decimal Place

- In the communication of PROFIBUS, all data are processed in integers even monitored data or parameters are decimal numbers.
- The decimal place is preset to each parameter. (Refer to “Decimal place” in the above tables.) Use them when decoding or encoding the integer numbers by the master controller in accordance with a need.

◆ Setting example of Velocity loop proportional gain VG.

- The following shows an example to set the velocity loop proportional gain VG to VG5.

Table 5-14: Parameter List (Refer to VG on the list.)

Parameter	Correspondence	Function	Initial setting	Data range	Unit	Decimal place
02	VG	Velocity loop proportional gain	1.0	0.1 – 255.0	–	1

- The actual parameter data shall be 450 (0000 01C2h) because the decimal pace of VG is one according to the table above. Therefore, the actual control input of VG45.0 will be processed as Figure 5-5.

Figure 5-5: Example: Control input of PROFIBUS for VG45.0

Bite	Value
4	PRM_SET_NO (_lower): 02h
5	PRM_SET_NO (_higher): 00h
6	PRM_SET_DATA (lowest): C2h
7	PRM_SET_DATA (_lower): 01h
8	PRM_SET_DATA (_higher): 00h
9	PRM_SET_DATA (highest): 00h

◆ Example for reading out of position loop proportional gain PG

- The following shows an example of the control output by a reading out command for position loop proportional gain.

Figure 5-6: Example: Control output of PROFIBUS by a reading out command for PG

Bite	Value
4	PRM_GET_NO (_lower): 01h
5	PRM_GET_NO (_higher): 00h
6	PRM_GET_DATA (lowest): 90h
7	PRM_GET_DATA (_lower): 01h
8	PRM_GET_DATA (_higher): 00h
9	PRM_GET_DATA (highest): 00h

- The result of readout of PG is 190h (400). The table below shows that the decimal place of PG is three, and thus PG400 is actually set to PG.

Table 5-15: Parameter Refer to PG on the list.)

Parameter	Correspondence	Function	Initial setting	Data range	Unit	Decimal place
01	PG	Position loop proportional gain	0.100	0.010 – 1.000	–	3

(Blank Page)

6. Power on

- When initialization of internal network module completes after the power is on, the Driver Unit gets in the mode where it can receive instructions from PROFIBUS.
- Confirm the following before communicating with PROFIBUS.
 - ◇ 7 segments LED
If it reports any one of C4, E0, E7 or E8 alarm.
 - ◇ Handy Terminal (Right after it is connected to the Driver Unit.)
It indicates the prompt “#”.

```
NSK MEGATORQUE
MS1A50_XXXX.X
XXXXXXXXXX
#
▲
```

Indicates the System is in PROFIBUS mode.

- If the Driver Unit fails to initialize the internal network module for some reason, the System indicates the following.
 - ◇ 7 segments LED
Reports any one of C4, E0, E7 or E8 alarm.
 - ◇ Handy Terminal (Right after it is connected to the Driver Unit.)
It indicates the prompt “:”.

```
NSK MEGATORQUE
MS1A50_XXXX.X
XXXXXXXXXX
:
▲
```

Indicates that the System is in the maintenance mode

6.1. Operation Mode

- The Driver Unit has two operation modes as shown below.
 - ◇ PROFIBUS mode
 - ◇ Maintenance mode
- Default is PROFIBUS mode after turning on the power.

6.1.1. PROFIBUS Mode

- The Driver Unit functions in accordance with instructions of PROFIBUS.
- The Handy Terminal indicates the prompt “#” when it is connected to the Driver Unit.

```
NSK MEGATORQUE
MS1A50_XXXX.X
XXXXXXXXXX
#
▲
```

Indicates the System is in PROFIBUS mode.

6.1.2. Maintenance Mode

- The Driver Unit functions in accordance with instructions from the Handy Terminal (RS-232C communication).
- The Handy Terminal indicates the prompt “:”.
- The maintenance mode is to tentatively control the Driver Unit when PROFIBUS is disabled for some reason.
- Some input signals of CN2 connector will be available in the maintenance mode. On the other hand the all inputs and some outputs of PROFIBUS will be disabled.
- Refer to “1.4. Validity of Inputs and Outputs by Operation Mode” for details.

```
NSK MEGATORQUE
MS1A50_XXXX.X
XXXXXXXXXX
:
▲
```

Indicates the System is in the maintenance mode.

6.1.3. Switching Operation Mode

- The Driver Unit can control only one communication device at a time. When switching the operation mode, input the command (CP) to change operation mode through the Handy Terminal. If the Motor is operating under the internal pulse train when switching the mode, it will automatically decelerate and stop.

6.1.3.1. Switch PROFIBUS Mode to Maintenance Mode

- 1) Confirm that the prompt is “#” (PROFIBUS mode).
- 2) Input the password.

```
#  
#  
#/NSK ON  
#
```

- 3) Execute command CP0.

- If the Motor is operating under the internal pulse train, it will decelerate and stop.

- 4) The prompt changes to “:” (maintenance mode) from “#”.

```
#  
#/NSK ON  
#CP0  
:
```

6.1.3.2. Switch Maintenance Mode to PROFIBUS Mode

- 1) Confirm that the prompt is “:” (Maintenance mode).
- 2) Input the password.

```
:  
:  
:/NSK ON  
:
```

- 3) Execute command CP1.

- If the Motor is operating under the internal pulse train, it will decelerate and stop.

- 4) The prompt will change to “#” (PROFIBUS mode) from “:”.

```
:  
:/NSK ON  
:CP1  
#
```

(Blank Page)

7. Additional Function, Command and Alarm

7.1. Additional Function

7.1.1. Override Function

- This function is to change the positioning velocity of Motor in accordance with the change ratio preset by parameter OV when a control input signal ORD from PROFIBUS is ON.
- The Driver Unit detects the current level of ORD input signal.
- When ORD input is ON, the change ratio [%] set by the parameter OV will be applied to the operation velocity in positioning operation through RS-232C command (MV), Home Return (HV), operation in Programmable Indexer (CV), and Jog (JV).
- The normal state is ORD input OFF. (Each positioning operation follows the set velocity with MV, HV, CV and JV respectively.)
- The override ratio may be set in the range of 0 – 200% with the parameter OV.
- Input of ORD will be invalid in the middle of positioning operation.
- When the maximum velocity set by the override function exceeds the allowable velocity of the Motor, the available maximum speed will be limited to the allowable velocity of the Motor.
- If the parameter OV is set to 0%, the Motor won't rotate by the input of ORD signal.

Figure 7 -1: Operation example: Input signal RUN

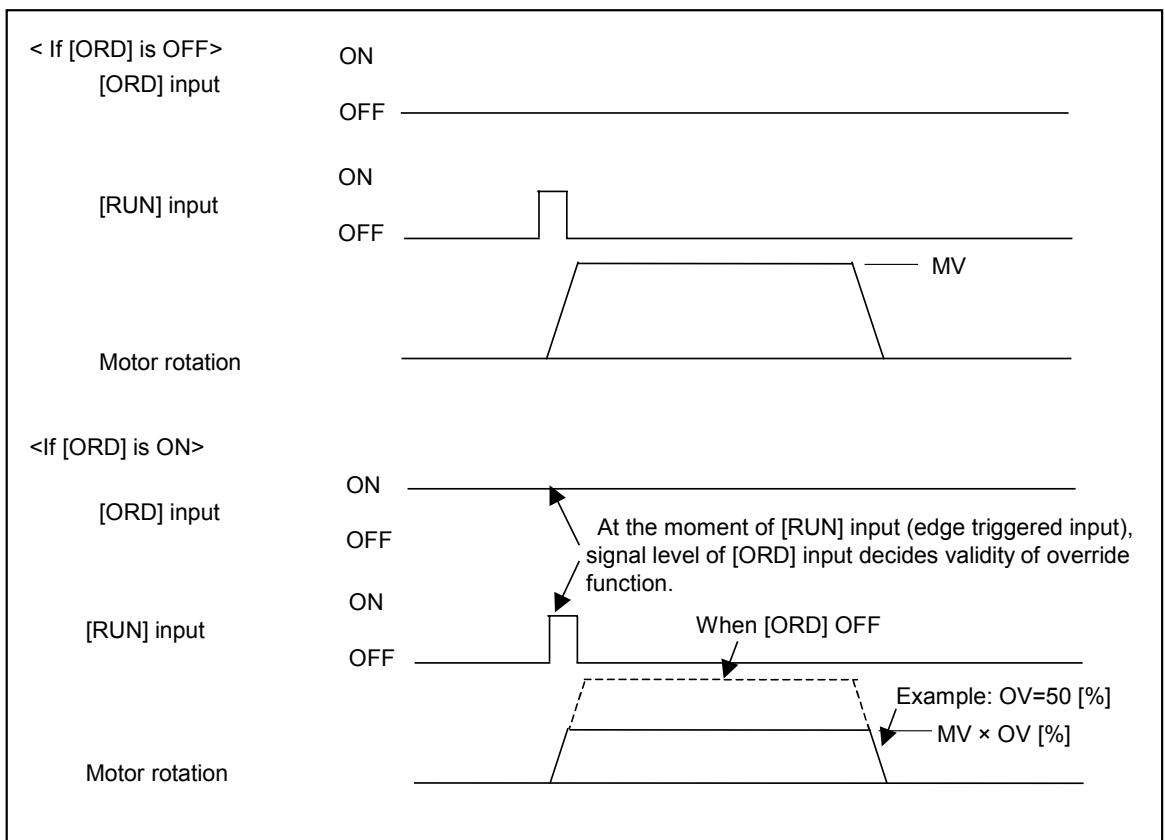

7.2. Additional RS-232C Command

- The following shows the additional commands and commands with expanded function.
- The command marked with ★ requires an entry of the password “/NSK ON.”

★ CP: Switch PROFIBUS/ Maintenance Mode

Format : CP data
 Data : data=0: Maintenance mode
 : data=1: PROFIBUS mode
 Default : 0

- This command is to select PROFIBUS mode or the maintenance mode of the Droker Unit.
- This command is used in case of maintenance. The settings in this mode won't be backed up by the memory.
- Input of ?CP reports the current setting.
- The operation mode at the starting depends on the result of initialization of PROFIBUS communication right after the power is turned on.
 - ◇ PROFIBUS mode : When the initialization of LSI of PROFIBUS communication was successful right after the power is turned on.
(The prompt “#” is indicated on the screen.)
 - ◇ Maintenance mode : When the initialization of LSI PROFIBUS communication has failed right after the power is turned on.
(The prompt “:” is indicated on the screen.)

Display format: In normal start

NSK MEGATORQUE MS1A50_XXXX.X XXXXXXXXXXXX # _____	_____ System reference number _____ Torque ROM reference number _____ Prompt # (For PROFIBUS mode)
--	---

Display format: In abnormal start

NSK MEGATORQUE MS1A50_XXXX.X XXXXXXXXXXXX : _____	_____ System reference number _____ Torque ROM reference number _____ Prompt : * C4 alarm is reported on 7seg. LED.
--	--

 **Caution:** When the operation mode is switched, the control input and output signals (CN2 and CN5) are switched as well: thus the Motor may start suddenly depending on the command of the master controller. When switching the operation mode, be sure to confirm the command of the master controller, and take an appropriate action for the safety.

IO: Input / Output Monitor

Format : IO data opt
Data : data = default, or 0: General readout of Inputs/Outputs
data = 1 General readout of Inputs/Outputs
(Reversed video for normally closed contacts)
data = 2 ...Readout of Inputs/Outputs related to
Programmable Indexer
data = 3 ...Readout of Inputs/Outputs of all operation
data = 4 ...Readout of Inputs/Outputs related to PROFIBUS
data = 5 ...Readout of Inputs/Outputs Programmable
Indexer with PROFIBUS
Optional code : opt = default...One shot readout
: opt = /RP ...Readout is repeated automatically.

- Reports the status (ON/OFF, open /closed) of the control Inputs/Outputs of CN2 and CN5 by zeros and ones.

1: Input ON, output closed

0: Input OFF, output open

- Press the [BS] key to terminate repeated readouts by IO/RP.

Figure 7-2: In case of IO4

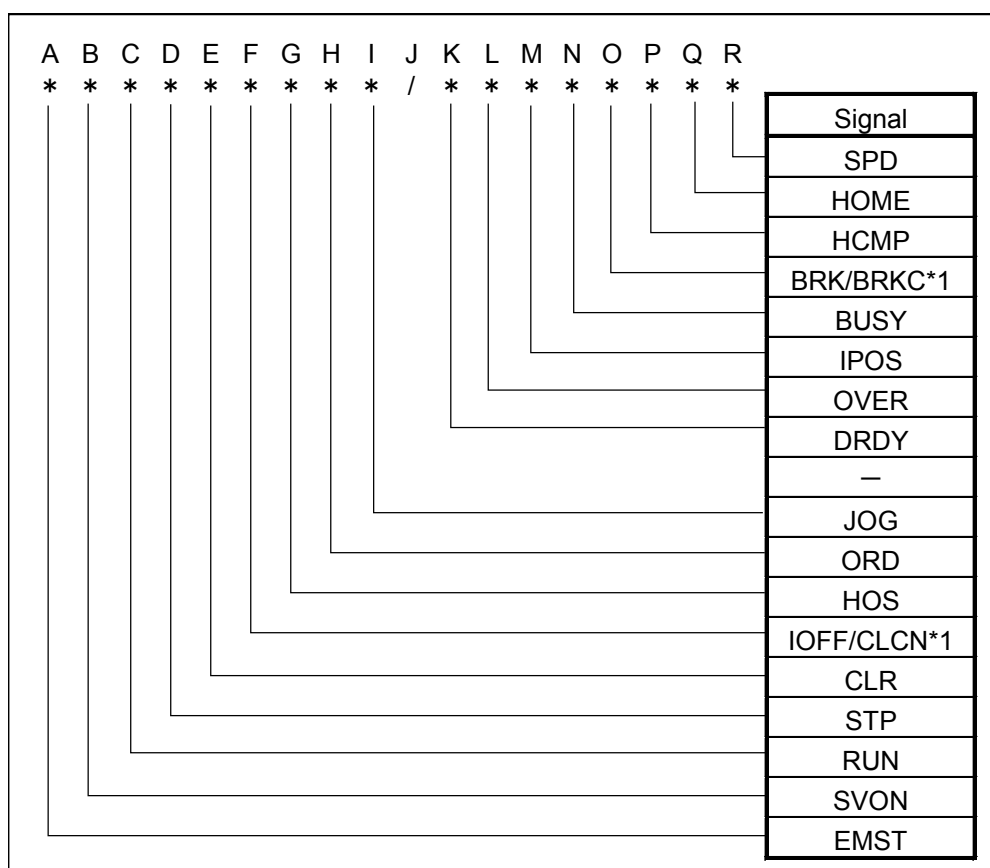

- *1: When using motor with brake combined with brake sequence function(BF1), signals Integrator off / Low gain will be used as Clamp cancel input, Brake output will be used as Brake control output.

Figure 7-3: In case of IO5

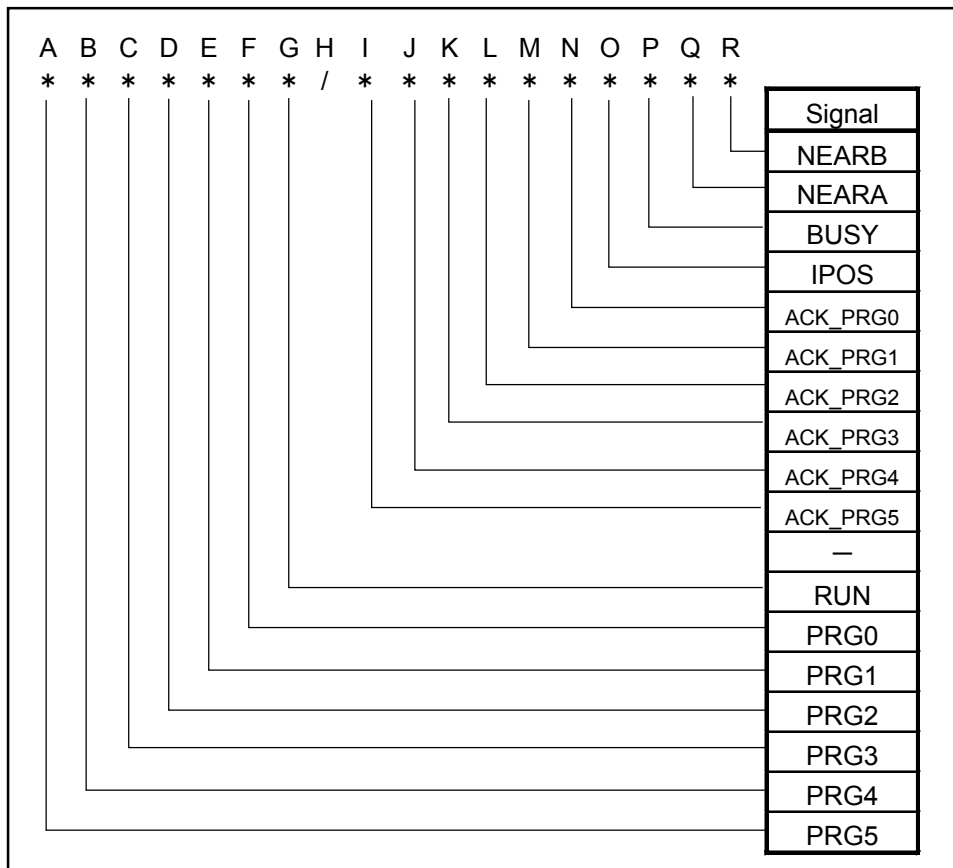

OV: Override

Format : OV data
 Data : 0 – 200 [%]
 Shipping set : 100
 Default : 0

- This is to set the velocity change ratio when ORD input of PROFIBUS is ON.
- Unit of data is 1%.
- If the data setting is zero (0) and ORD input is ON, the Motor does not rotate even for instructions of motion command.
- If the OV setting exceeds the allowable Motor velocity, the rotational speed is limited to the allowable velocity of the Motor.
- Refer to “7.1.1. Override Function” for details.
- TS or ?OV command reports the current setting.

7.2.1. Additional Parameter List

Table 7-1

Parameter	Function	Password	Shipping set	Data range	Current setting (User)
OV	Override velocity	Not required	100	0 – 200	

7.3. Additional Alarm

7.3.1. Fieldbus Error

- The alarm reports that an error is detected in the interface of PROFIBUS.
- The PROFIBUS communication will be disabled because of the interface error.
- This report will be outputted to 7 segments LED on the Driver Unit and RS-232C communication terminal.

Table 7-2

DRDY output	Open (alarm)
Motor state	Servo off
7 segments LED	C4
TA readout	C4>Fieldbus Error
Clear alarm	Turn on the power again.

- If this alarm is reported, input TA/HI command through an RS232C terminal and confirm the alarm sub-code.
- Cause and remedy are shown in the table below.

Table 7-3

Cause	Remedy
Defective interface board	Replace the Driver Unit.

(Blank Page)

World-wide Manufacturing and Marketing Organization

NSK Ltd. Headquarters, Tokyo, Japan

Americas & Europe Department
Phone: 03-3779-7120
Asian Marketing & Sales Department
Phone: 03-3779-7121

NSK Corporation

U.S.A. : Ann Arbor Phone: 734-761-9500

NSK Precision America, Inc.

U.S.A. : Chicago Phone: 630-620-8500
: Los Angeles Phone: 562-926-3578
: Ann Arbor Phone: 761-761-9500

NSK Canada Inc.

CANADA : Toronto Phone: 905-890-0740
: Montreal Phone: 514-633-1240
: Vancouver Phone: 800-663-5445

NSK Rodamientos Mexicana, S.A. de C.V.

MEXICO : Mexico City Phone: 5-301-2741,5-301-3115

NSK Brasil Ltda.

BRASIL : São Paulo Phone: 001-3269-4700

NSK UK LTD

ENGLAND : Ruddington Phone: 0115-936-6600

NSK Deutschland G.m.b.H

GERMANY : Düsseldorf Phone: 02102-4810
: Stuttgart Phone: 0711-79082-0
: Leipzig Phone: 0341-5631241

NSK France S.A.

FRANCE : Paris Phone: 1.30.57.39.39
: Lyon Phone: 72.15.29.00

NSK Italia S.P.A.

ITALIA : Milano Phone: 02-995191

NSK Spain S.A.

SPAIN : Barcelona Phone: 93-575-1662

NSK Australia Pty, Ltd.

AUSTRALIA : Melbourne Phone: 03-9764-8302
: Sydney Phone: 02-9893-8322

NSK New Zealand Ltd.

NEW ZEALAND : Auckland Phone: 09-276-4992

NSK Korea Co., Ltd.

KOREA : Seoul Phone: 02-3287-6001

NSK Singapore (Pte) Ltd.

SINGAPORE : Singapore Phone: (65) 2781 711

NSK Bearing (Thailand) Co., Ltd.

THAILAND : Bangkok Phone: 02-6412150-60

Taiwan NSK Precision Co., Ltd.

TAIWAN : Taipei Phone: 02-591-0656

MEGATORQUE[®] MOTOR SYSTEM
User's Manual (ESB Driver Unit System)
Instructions for PROFIBUS
Document Number: C20126-02

March 14, 2003 1st Edition 1st Printing
November 20, 2003 2nd Edition 1st Printing

NSK Ltd.

NSK