

# Vinotemp®

A PROUD HERITAGE OF EXPERIENCE & QUALITY



## Wine Cellar

VT-16TEDS (16 bottle)

OWNER'S MANUAL

*Vinotemp*

WWW.VINOTEMP.COM

## YOUR WINE CELLAR

This unit can be used for Storage and/or Service. The unit has a glass door and soft interior light that you can leave on to elegantly display your wine.

## SERVING WINES

Storing wines at the proper temperature is important. To preserve them as long as possible wine should be stored at approximately 55° Fahrenheit. However, the chart below suggests the optimal drinking temperature for the different styles of wine.

°C	°F	Wine Style
19	66	Armagnac, Brandy, Cognac
18	64.5	Full Bodied Red wines, Shiraz
17	62	Tawny Port
15	59	Medium Bodied Red Wines
14	57	Amontillado Sherry
13	55.5	Light Bodied Red Wines
12	53.5	Full Bodied White Wines
11	52	Medium Bodied White Wines
10	50	Rosé, Light Bodied White Wines
9	48	Vintage Sparkling
8	53.5	Fino Sherry
7	44.5	Non Vintage Sparkling

## TABLE OF CONTENTS

GENERAL OPERATING INSTRUCTIONS.....	4
IMPORTANT SAFETY INSTRUCTIONS .....	4
ELECTRICAL CONNECTION .....	5
CABINET AND CIRCUIT DIAGRAM.....	6
TECHNICAL DATA .....	7
INSTALLATION INSTRUCTIONS .....	8
OPERATING YOUR WINE CELLAR .....	8
CARE AND MAINTENANCE .....	9
PROBLEMS WITH YOUR WINE CELLAR.....	10
TERMS OF SALE AND WARRANTY .....	11

## **GENERAL OPERATING INSTRUCTIONS**

Remove all external and internal packaging from your wine cellar. Be sure that all parts have been included before discarding any packaging materials. You may want to keep the box and packing materials for use at a later date.

Upon receipt and inspection of unit, the supply cord must be replaced if it is damaged. Contact our customer service at 1-800-777-8466 or [info@vinotemp.com](mailto:info@vinotemp.com).

### **READ ALL INSTRUCTIONS BEFORE USING THIS WINE CELLAR**

-Save these instructions-

## **IMPORTANT SAFETY INSTRUCTIONS**

To reduce the risk of fire, electrical shock, or injury when using your appliance, follow these basic precautions:

- Do not use if supply cord is damaged. If damaged, it must be replaced by the manufacturer or a similarly qualified person in order to avoid hazard.
- Ensure the cellar is always unplugged before cleaning.
- To clean the cellar, use only mild detergents or glass cleaning products. Do not use harsh detergents or solvents.
- Do not store food in wine cellar, as interior temperature may not be cool enough to prevent spoilage.
- Keep appliance away from any heat source or direct sunlight.
- For stability, the appliance must be placed on a solid, flat surface. It should not be laid on any soft material.
- Do not place any other appliance on top of the wine cooler.
- The wine cooler is an electrical appliance. To avoid injury or death from electrical shock, do not operate the wine cooler with wet hands, while standing on a wet surface or in other wet conditions.
- When positioned or if moving the appliance, ensure that it is not set horizontally, positioned at an angle of more than 45°, or turned upside down.
- Never lift or carry the wine cellar by the cord.
- Keep the cord away from heated surfaces.

- This wine cellar is for indoor household use only. Any other use will void the warranty.
- Do not plug into the power socket before setup is completed.
- Always unplug an appliance from outlet when not in use. Never pull cord to remove plug from outlet. Grasp plug and pull to disconnect.
- **WARNING:** Risk of child entrapment. Junked or abandoned appliances are still dangerous. **Before you throw away an old wine cellar:** Take off the door and leave the shelves in place so that children may not easily climb inside, or take other action to ensure the cellar is harmless.
- Never allow children to operate, play with, or crawl inside the appliance.
- Never clean appliance parts with flammable fluids. The fumes can create a fire hazard or explosion.
- Do not store or use gasoline or any other flammable vapors and liquids in the vicinity of this or any other appliances. The fumes can create a fire hazard or explosion.

## ELECTRICAL CONNECTION

For your protection, this unit is equipped with a 3-conductor cord set that has a molded 3-prong grounding-type plug, and should be used in combination with a properly connected grounding-type outlet as shown in figure A.

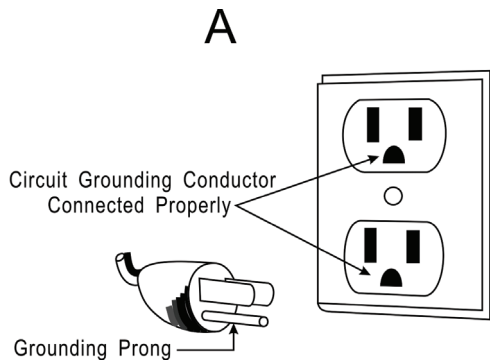

It is not recommended to use this cellar with an extension cord or power board. Please ensure that the appliance is plugged directly into the electrical outlet.

## CABINET DIAGRAM

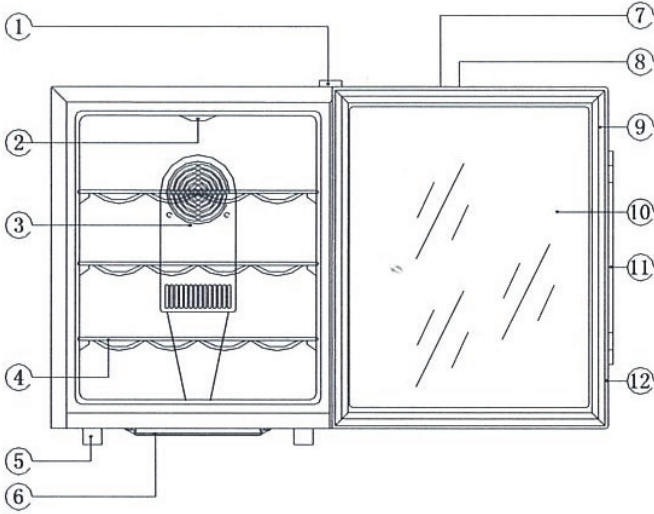

- |                |                                |
|----------------|--------------------------------|
| 1. Hinge Cover | 7. Temperature Control Buttons |
| 2. Light       | 8. Light Switch Button         |
| 3. Fan Cover   | 9. Magnetic Seal               |
| 4. Shelf       | 10. Glass                      |
| 5. Foot        | 11. Door Handle                |
| 6. Water Box   | 12. Door Frame                 |

## CIRCUIT DIAGRAM

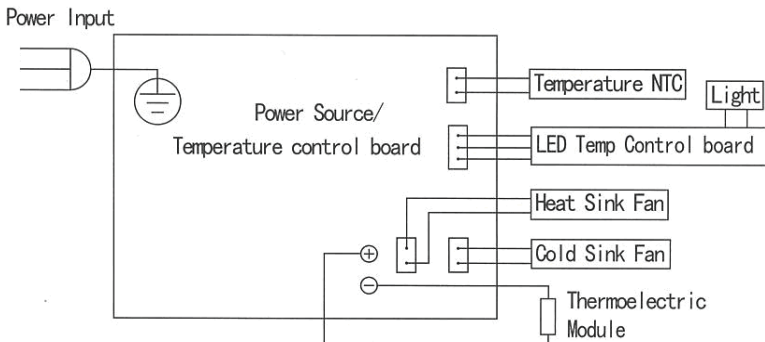

## TECHNICAL DATA

Model No.	VT-16TEDS
Capacity	46L / 16 Bottles
Voltage	110V
Current	1A (59°)
Protection Class	I
Frequency	60Hz
Climate Class	SN;N
Input Power	70W
Power Consumption (kW · h/24h)	1 (@59°)
Temperature Range	54-66°F
Approx. Net Weight	34.1 Lbs
Approx. Gross Weight	38 Lbs
Approx. Unit Size (HxWxD)	17.1"x20"x18.9"
Approx. Packing Size (HxWxD)	19.5"x21"x21.2"

# INSTALLATION INSTRUCTIONS

## Before Using Your Wine Cellar:

- Remove any exterior and interior packing material.
- Check to be sure the following parts are included:
  - For 16 Bottle Wine Cellar, 3 slide out shelves.
  - 1 instruction manual.
- Before connecting the appliance to the power source, let it stand upright for approximately 2 hours. This will reduce the possibility of a malfunction in the cooling system from handling during transportation.
- Place your appliance on a surface that is strong enough to support the appliance when it is fully loaded.
- To level your appliance, adjust the front legs at the bottom of the appliance.
- Designed for freestanding installation only, away from direct sunlight and sources of heat (stove, heater, radiator, etc.). Direct sunlight may affect the acrylic coating and heat sources may increase electrical consumption. Several inches clearance is required at rear for proper air circulation.
- Clean the interior surface with lukewarm water using a soft cloth.

## OPERATING YOUR WINE CELLAR

It is recommended that you install the wine cellar in a place where the ambient temperature is between 50-80°F. If the ambient temperature is above or below recommended temperature, the performance of the unit may be affected. Placing in extreme cold or hot conditions may cause interior temperature to fluctuate. The range of 54-66°F may not be reached. Not intended for garage or basement installs. The temperature may fluctuate depending on whether or not the interior light is on or off or whether the bottles are located on the upper/middle or lower section. Close the cellar door immediately after putting in any items so the inside temperature will not rise dramatically.



## **Using the Buttons on the Display Panel**

You can set the temperature by pushing the control buttons. There are two buttons on the panel " + " and " - " to adjust the temperature by 1°F increments from 54-66°F. You can turn the interior light on or off by pressing the light button.

## **CARE AND MAINTENANCE**

### **Cleaning Your Wine Cellar**

- Unplug the wine cellar and remove the bottles.
- Wash the inside with a warm water and baking soda solution. The solution should be about 2 tablespoons of baking soda to a quart of water.
- The outside of the wine cellar should be cleaned with mild detergent and warm water.
- Unscrew the water box at the bottom, and wash it.
- Wipe dry with a soft cloth.

### **Moving Your Wine Cellar**

- Remove all the bottles.
- Securely tape down all loose items inside your wine cellar.
- Turn the leveling legs up to the base to avoid damage.
- Tape the door shut.
- Be sure the wine cellar stays in the upright position during transportation.

## PROBLEMS WITH YOUR WINE CELLAR

You can easily solve many common wine cellar problems, saving you the cost of a possible service call. Try the suggestions below to see if you can solve the problem before contacting Vinotemp at [info@vinotemp.com](mailto:info@vinotemp.com).

### TROUBLESHOOTING GUIDE

PROBLEM	POSSIBLE CAUSE
Wine cellar does not operate	<ul style="list-style-type: none"> <li>• Not plugged in.</li> <li>• Using wrong voltage.</li> <li>• The circuit breaker tripped or there is a blown fuse.</li> </ul>
Wine cellar is not cold enough	<ul style="list-style-type: none"> <li>• Check the temperature control setting; external environment may require a higher setting.</li> <li>• The door is opened too often.</li> <li>• The door is not closed completely.</li> <li>• The door seal does not seal properly.</li> <li>• The wine cellar does not have the correct clearances to operate efficiently and safely.</li> </ul>
Light does not work	<ul style="list-style-type: none"> <li>• Call the service center.</li> </ul>
Vibrations	<ul style="list-style-type: none"> <li>• Check to assure that the wine cellar is level.</li> </ul>
Wine cellar seems to make too much noise	<ul style="list-style-type: none"> <li>• The wine cellar is not level.</li> <li>• Check the fans inside and at the back of the unit.</li> </ul>
Door will not close properly	<ul style="list-style-type: none"> <li>• The wine cellar is not level.</li> <li>• The doors were not properly installed.</li> <li>• The seal is weak.</li> <li>• The shelves are out of position.</li> </ul>
Temperature LED display is blank	<ul style="list-style-type: none"> <li>• Main control board does not work.</li> <li>• The Power Control Board is not functioning.</li> <li>• There is some problem with the plug (no power supply).</li> </ul>
Temperature LED display error	<ul style="list-style-type: none"> <li>• Display has suffered too much wear and tear.</li> <li>• Temperature sensor has been cut off.</li> </ul>
Buttons are not functional	<ul style="list-style-type: none"> <li>• Temperature controller panel is damaged.</li> </ul>

# TERMS OF SALE AND WARRANTY

Vinotemp International ("Seller") and the person or entity that acquires these goods from Seller ("Purchaser") hereby fully agree to the following terms and conditions of the sale: Shipping fees are the responsibility of the Purchaser whether freight prepaid or freight collect. Seller assumes no responsibility for the goods sold to the Purchaser once the goods have left the Seller's premises, including, but not limited to, late delivery, or for events caused by any difficulty carrier incurs in attempting to fit the goods into the Purchaser's place of business or residence. Purchaser assumes all responsibility for delivery, payment of freight, access, measurement, installation, hook-up, wiring, moving and storage of the goods. Transportation of all goods is subject to the terms and conditions which the moving carrier imposes on Purchaser including, but not limited to, additional charges imposed per flight of stairs. Any claim for damages incurred during shipment by the carrier of the goods are insured and handled directly with the carrier. Any damages due to manufacture defects will be handled directly with Vinotemp International, subject to the limited warranty.

All sales are final, and unless authorized in writing by the Seller, Purchaser may not return the goods, under any circumstance. If Purchaser refuses to accept the goods, under any circumstance, the Purchaser is liable for the return and cost of freight both ways, and if Seller does take back the goods, there will be a restocking charge that is 35% of the purchase price of the goods. Purchaser must notify Seller of non-conforming goods within four days of delivery, after which time all goods are deemed accepted. Finance charges begin the date of invoice. Title to the goods does not pass until payment is received in full by Seller and Seller retains a security interest in the goods until they are paid for in full.

**LIMITED WARRANTY:** Seller warrants that the goods will be free of defects in materials and workmanship as follows for Thermoelectric Units: Parts ninety days from the date of sale. Removal and re-installation of unit is not included in warranty. There is no warranty on parts purchased separately. Purchaser's exclusive remedy is limited, at Seller's option; to repair or replace defective part[s] with either new or factory reconditioned part[s]. Purchaser is responsible for shipping the unit pre-paid to designated facility and Seller will pay return shipping charges in the continental United States for items repaired under warranty within three months from date of sale. Improper placement of the unit will void the warranty. This limited warranty does not cover damage due to such things as accident, misuse, abuse, mishandling, neglect, acts of God, fires, earthquakes, floods, high winds, government, war, riot or labor trouble, strikes, lockouts, delay of carrier, unauthorized repair, or any other cause beyond the control of the Seller, whether similar or dissimilar to the foregoing. Seller is not responsible for any damages caused to Seller's property resulting from the goods. This limited warranty applies only inside the Contiguous US. (Alaska, Puerto Rico and Hawaii are not warranted.)

Purchaser understands and acknowledges that the goods sold here are wine cellars or other similar units. Purchaser assumes all risk of using these units, including risk of spoilage, humidity variations, temperature variations, leaks, fire, water damage, mold, mildew, dryness and similar and any other perils that might occur.

Seller is not responsible for incidental or consequential damages, and there are no warranties, expressed or implied, which extend beyond the Limited Warranty described above. The implied warranties of merchantability and of fitness for a particular purpose are hereby expressly disclaimed. Some states do not allow the exclusion of incidental or consequential damages, or a waiver of the implied warranties of fitness and/or merchantability, so the above limitations may not apply to you. This warranty gives you specific legal rights and you may also have other rights which vary state to state.

In the event of any dispute between Seller and Purchaser arising out of or relating to these terms and conditions or to the goods sold generally, Purchaser must first file a written claim with Seller within ten days of the occurrence giving rise to the claim and wait an additional thirty days for a response before initiating any legal action. The sale and all terms are subject to California law. Any legal proceeding arising out of or relating to these terms and conditions or to the goods sold generally shall be brought solely and exclusively in the County of Los Angeles. In no event may Purchaser initiate any legal proceeding more than six months after the occurrence of the event giving rise to the dispute.

The above terms and conditions are the only ones governing this transaction and Seller makes no oral representations of any kind. These Terms and Conditions can only be modified in writing, signed by both Purchaser and Seller. 2008

## SERVICE & IMPORTANT NOTICE

Upon receipt and inspection of unit, the supply cord must be replaced if it is damaged. Contact customer service at 1-800-777-8466 or [info@vinotemp.com](mailto:info@vinotemp.com).

The manufacturer has a policy of continuous improvement on its products and reserves the right to change materials and specifications without notice.

### WARNING:

Please do not place the unit within reach of children.  
For adult use only.

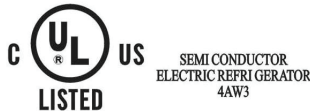

17631 S. Susana Road  
Rancho Dominguez, CA 90221

**[www.vinotemp.com](http://www.vinotemp.com)**

Vinotemp is a registered trademark of Vinotemp International. All products, features, and services are subject to change without notice. We cannot guarantee the accuracy of the contents of this document. We disclaim liability for errors, omissions, or future changes.

© 2008 Vinotemp International. All rights reserved.