

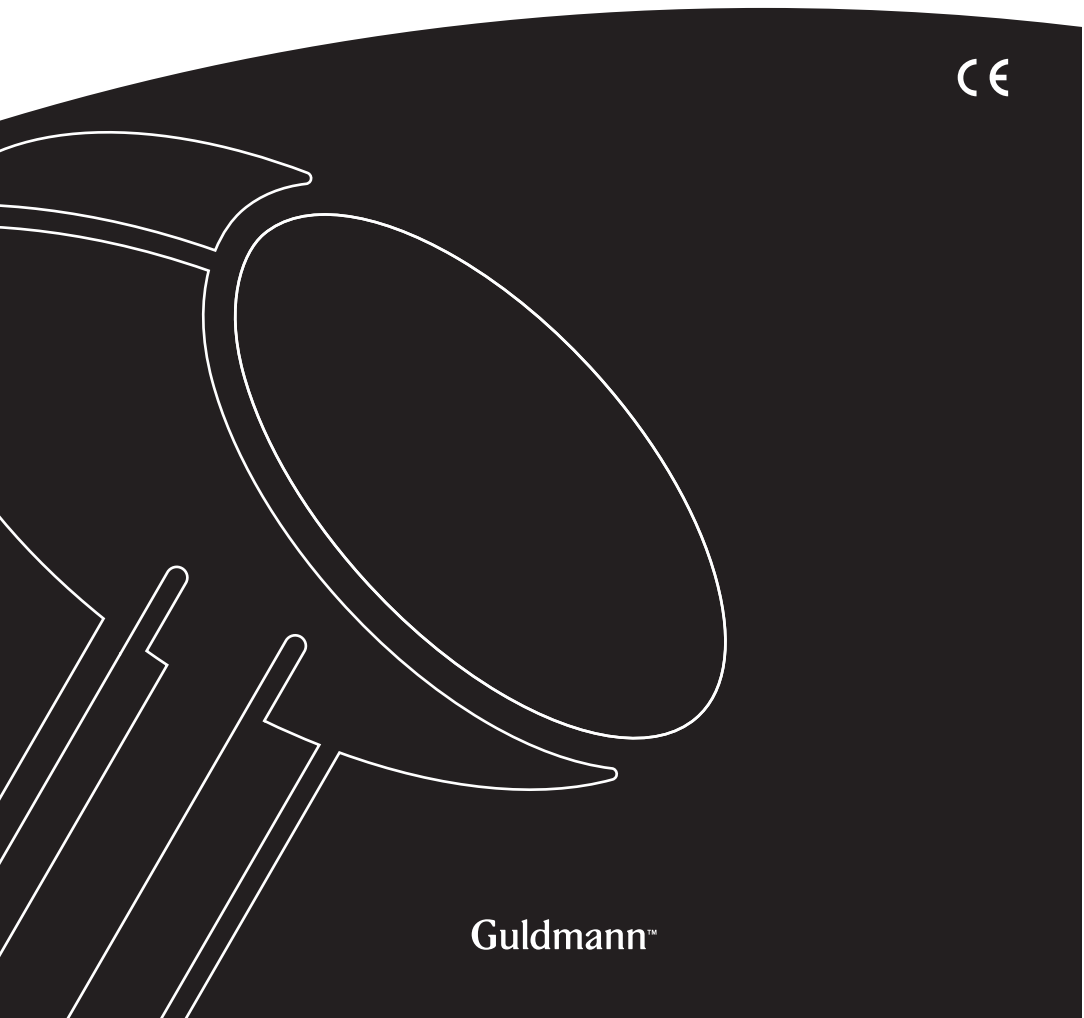

## GB/US . . . .GH1 F Ceiling Hoist

Vers. 3.00

CE



Guldmann™

---

## GH1 F Ceiling Hoist

### Hoist numbers:

554192 - 175 kg

554125 - 205 kg

554126 - 255 kg

---

<b>1.00</b>	<b>Purpose and use</b>	<b>4</b>
1.01	Manufacturer	4
1.02	Intended use	4
1.03	Important/Precautions	4
1.04	Load limits on your GH1 F system	5
1.05	Unpacking and preparation	5
1.06	Placing a new GH1 F hoist in an existing rail system	7
1.07	Power supply	7
1.08	Installation of the lifting hanger before use	8
1.09	Lifting sling	9
1.10	Swing kit	10
<hr/>		
<b>2.00</b>	<b>Description of functions</b>	<b>11</b>
2.01	Pictograms	11
2.02	Indicator lamps and audio signals	12
2.03	Audio signals	12
2.04	Operation	13
2.05	Installation	15
2.06	Deinstallation	16
2.07	Lock, Travelling trolley for GH1 F	17
<hr/>		
<b>3.00</b>	<b>Transport/running in the rail system</b>	<b>17</b>
3.01	Safety functions	17
3.02	Safety functions, installation/deinstallation	18
3.03	Installation lock	19
<hr/>		
<b>4.00</b>	<b>Accessories</b>	<b>20</b>
<hr/>		
<b>5.00</b>	<b>Transport and storage</b>	<b>22</b>
<hr/>		
<b>6.00</b>	<b>Maintenance and storage</b>	<b>22</b>
6.01	Cleaning	22
6.02	Storage	24
6.03	How to prevent/avoid corrosion?	24
6.04	The owner's daily maintenance duty	24
6.05	Disposal of the GH1 F including battery	24
<hr/>		
<b>7.00</b>	<b>Service and lifetime</b>	<b>24</b>
7.01	Lifetime	24
7.02	Safety/service inspections	25
7.03	Service inspection, travelling trolley for GH1 F	25
7.04	Trouble-shooting, GH1 F	26
7.05	FAQ's	26

---

<b>8.00</b>	<b>Classification</b>	<b>27</b>
<b>9.00</b>	<b>Technical specifications</b>	<b>29</b>
<b>10.00</b>	<b>EC-Declaration of conformity</b>	<b>32</b>
	<b>USA and countries outside the EU</b>	<b>33</b>
A.	Users guide	33
B.	WARRANTY	33

---

---

**1.00****Purpose and use**

---

**1.01****Manufacturer**

V. Guldmann A/S  
Graham Bells Vej 21-23A  
DK-8200 Aarhus N  
Tlf. + 45 8741 3100  
Fax + 45 8741 3131  
www.guldmann.com

---

**1.02****Intended use**

GH1 F is a ceiling-mounted hoist which covers the need for lifting or moving a person with disabilities in the home care sector, nursing homes, rehabilitation centres, riding schools and swimming pools.

The flexibility of GH1 F lies in the fact that it can be rapidly and easily – with the least manual handling – transferred from one rail system to another. Installing it on and deinstalling it from a rail system is partially automated and is carried out without the use of any tools.

GH1 F with lifting accessories is transported and stored in a specially designed transport trolley.

**Conditions for use**

The use of the GH1 F is subject to the following:

- The GH1 F should only be used by trained personnel.
  - The maximum nominal load, 175 kg (385 lbs), 205 kg (450 lbs) and 255 kg (560 lbs), respectively, must not be exceeded (*section 1.04*).
  - The instruction offered by Guldmann to all customer groups in connection with the purchase of a ceiling-mounted hoist has been received.
  - The helper pays attention to the well-being of the user when using the hoist.
  - The hoist is used in rail systems which are installed, tested and approved according to DS/EN 10535 and Guldmann's stipulations.
  - Only technicians who have been certified by Guldmann may install and test the rail systems.
  - The hoist is used with a Guldmann lifting hanger (*section 1.08*).
  - The hoist is used with a Guldmann lifting sling or with other suitable slings (*section 1.09*).
- 

**1.03****Important/Precautions**

- Read the instructions carefully before using the GH1 F and in connection with cleaning (point 6.01) and service of the hoist.
- The GH1 F's maximum load must never be exceeded.
- The GH1 F may only be used to lift a person.
- The red strap for the emergency stop and the emergency lowering must be adjusted to the helper's reach, and must not be removed.
- If the GH1 F fails while in use, stop using the hoist and contact the Guldmann Service Team for repair.

- The GH1 F is controlled by a microprocessor PCB, which can be damaged by static electricity if touched without the necessary precautions, (see point 1.07)
- The electronics may only be serviced by Guldmann approved service technicians.
- For safety reasons the side cover may only be dismantled when the emergency stop is activated (see point 3.01).

**Re: EMC**

If electromagnetic or other influences occur between this product and other products, these products must not be used together.

**1.04**

**Load limits on your GH1 F system**

Read the labels which indicate the maximum load limits of the components. The component which has the lowest load limit, e.g. the lifting hanger, the lifting sling, or other equipment, determines the maximum load limit of the entire system. The maximum load limit must not be exceeded. Please note that the load limit may change when different components are used on a daily basis, e.g. lifting hangers, lifting slings.

**1.05**

**Unpacking and preparation**

**Visual check of GH1 F**

If it appears that GH1 F has been damaged when you unpack it, it must not be used until it has been checked by a qualified person or by the Guldmann Service Team.

**Contents of the boxes**

**GH1 F hoist module (1)**

1. GH1 F
2. Hand control
3. Charger
4. Manual

**Travelling trolley for GH1 F (2)**

1. Travelling trolley for GH1 F
2. Manual
3. Label for rail system

**Transport trolley for GH1 F (3)**

1. Handle
2. Underframe
3. Bag for sling
4. Two holders for cross lifting hanger
5. Nuts and bolts
6. Manual

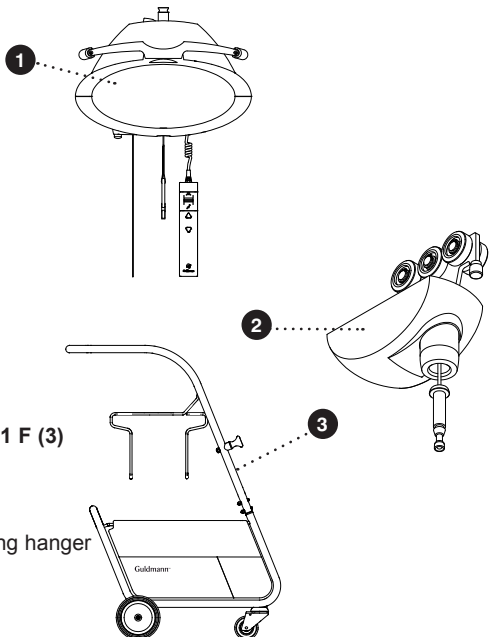

### Button for reset of emergency stop

GH1 F is delivered with the emergency stop activated in order to ensure that the battery is not being discharged during long-term storage. To deactivate the emergency stop, the plastic cap around the "reset" button must be removed, and the "reset" button must be pressed in.

### Mounting of side cover

GH1 F is standard delivered with side cover in 4 different designs.

Before starting to mount the side cover it is important, for safety reasons, to make sure that the emergency stop is activated (see *point 3.01*).

The chosen side covers are fitted on the side of GH1 F by bending the cover slightly and placing it in the groove at the side of GH1 F.

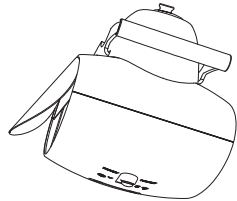

### Exchange of side cover

If you want to change the appearance of GH1 F, the side cover can be exchanged or turned. Before starting to mount the side cover it is important, for safety reasons, to make sure that the emergency stop is activated.

The side cover is dismantled by inserting for instance a flat screwdriver in the opening between the groove and the cover and tilt the cover upwards and out. The side cover is fitted on the side of GH1 F by bending the cover slightly and placing it in the groove on the side of GH1 F.

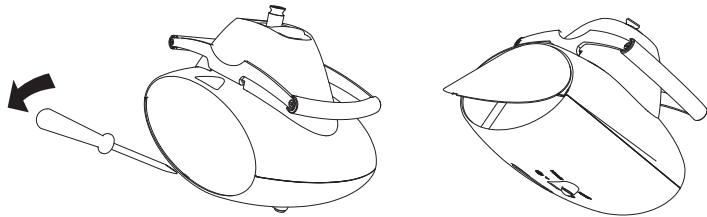

---

**1.06****Placing a new GH1 F hoist in an existing rail system**

Please notice, when placing a new GH1 F hoist in an existing rail system it must be ensured that:

- The rated max load of the rail system, must be equal or higher than the max load of the new hoist.
  - If there is no max load mentioned on the rail system, the rail system must then be checked according to the guideline in the installation manual (distance between bracket according to max load).
  - If the brackets are not visible, then a load test with 1.5 x max load of the hoist must be performed minimum 20 min. During the test the deflection of the rails must not be higher than 1/200 of the length of the rail.
  - If it is not possible to do any of the above mentioned, please contact Guldmann or their representative.
- If the rail system can not be rated to the same max load as the hoist, then extra brackets must be installed according to the installation manual (distance between brackets according to max load).

---

**1.07****Power supply**

GH1 F is equipped with a battery that requires regular recharging. The power supply must be connected to the power socket.

The enclosed power supply must always be used.

**Safety concerning static electricity (ESD)**

Service technicians and installers **must** use an ESD-safety package consisting of a mat, a ground wire, and a bracelet.

The technician/installer connects the mat to a grounding point, for instance a radiator or a water pipe. The technician/installer must then put on the bracelet and connect it to the mat. If it is not possible to find a grounding point, the mat and the bracelet must be used as a minimum.

Only then is it allowed to work with the PC Board or components where it is possible to come into contact with the PC Board.

Lifting hangers from other manufacturers

Guldmann shall not be liable for faults or accidents that may occur as a result of using lifting hangers made by other manufacturers.

If there is any doubt about the selection or use of a lifting hanger, please contact your supplier.

The lifting hanger can be installed to the lifting strap without the use of any tools.

Hold the lifting hanger in the right hand and press the yellow button using the thumb as shown (Fig. 1).

Insert the strap attachment in the slot on the lifting hanger top cover with the open side facing down (Fig. 2a, 2b) and release the yellow button (fig. 2c).

Rotate the strap attachment to a vertical position (fig. 3).

Check that the yellow button has returned to its locked position by checking that it is flush with the cover of the lifting hanger and that the strap attachment can rotate freely.

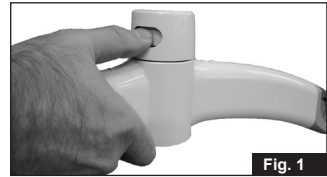

Fig. 1

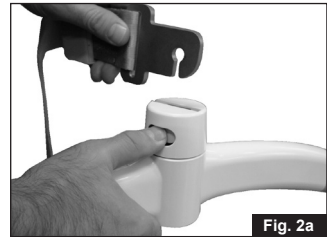

Fig. 2a

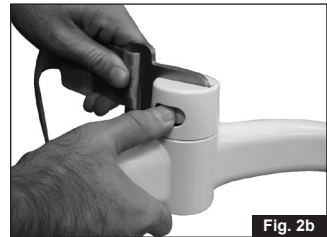

Fig. 2b

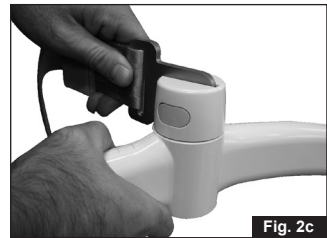

Fig. 2c

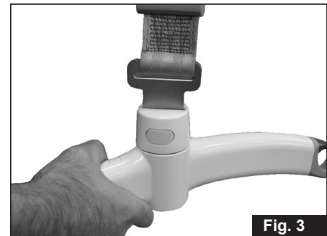

Fig. 3



## 1.09

### Lifting sling

A lifting sling with four to eight lifting straps designed for mounting on hooks should be used when using a Guldmann lifting hanger. Place the straps on the hooks. Make sure that the rubber safety catch returns to its start position, so the straps can not unintentionally fall off.

### Slings made by other manufacturers

Guldmann shall not be liable for faults or accidents that may occur as a result of using lifting slings made by other manufacturers.

***If there is any doubt about the selection or use of a lifting sling, please contact your supplier.***

Guldmann shall not be liable for faults or accidents due to incorrect use of the lifting sling, or for reasons of inadequate attention on the part of the carer or user.

### Attaching the lifting sling

Place the straps from the lifting sling on the hooks on the lifting hanger. Start with the uppermost set of straps (from the back) and then take the lowest set of straps (from the legs).

### Caution!

**Be careful when attaching the lifting sling on the hooks. Check that the straps have been pulled completely through the rubber safety catch (A) and into place in the lifting hanger's hooks. When pressing the up button to lift the user, check again that all the straps remain correctly placed in the lifting hanger's hooks (fig. 1a and fig. 1b).**

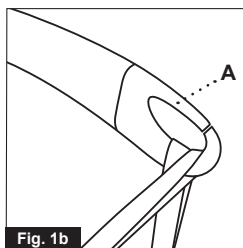
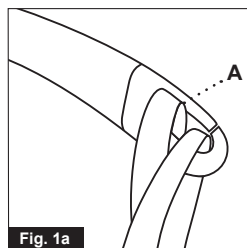

### **Lifting to and from a seated position**

When lifting a user from e.g. a wheelchair, move the GH1 F towards the person to be lifted. The lifting hanger should be at the same height as the user's chest and should not be moved further in over the user than to approximately mid-thigh position.

Place the lifting hanger parallel to the user's shoulders.

Place the lifting sling behind the user's back between the back of the chair and the user's back. The center marks of the lifting sling should follow the user's spine.

Lead the leg straps along the outer sides of the user's shins and beneath the thighs between the hollow of the knees and the hip joints. Cross the leg straps in front of the user.

All four lifting straps are now ready to be attached. The lifting sling can now be mounted on the lifting hanger.

### **Lifting to and from lying position in bed**

Bring the lifting hanger over the centre of the person to be lifted. Place the lifting hanger parallel to the user's shoulders.

Turn the user onto his or her side. The present sling should be placed so that its top is at the same height as the top of the user's head. Now position the sling over the user so that the center marks follow the user's spine. Turn the user onto his or her back and pull out the remaining part of the lifting sling.

Place the leg straps beneath the user's thighs and cross them. All four lifting straps are now ready to be attached and the lifting sling can now be mounted on the lifting hanger. It is an advantage to elevate the head of the bed so that the user is sitting up.

For further information, please refer to the user manual for the lifting sling in question.

#### ***Important!***

Only persons who have received competent instruction regarding the use of lifting equipment and fitting of slings should use the hoist.

Plan the move. Avoid leaving the user in the lifting sling unattended.

The GH1 F lifts quickly and powerfully. Before lifting, check that the user is completely free of his/her surroundings. The user's head, arms, hands and feet must not be in danger of becoming trapped. Be careful with any tubes and wires that are attached to the user.

Check that the hand control and hand control cable is free of hanger, user and other object before the hoist is activated up or down moved.

If the hoist is used correctly, the user should only be lifted to the extent that she/he is clear of the surface and should be moved at this height.

---

## **1.10**

### **Swing kit**

A swing kit must not be used in conjunction with GH1 F.

2.00

Description of functions

Information panel on the GH1 F bottom surface.

Designation of type and maximum load

Green/yellow indicator lamp

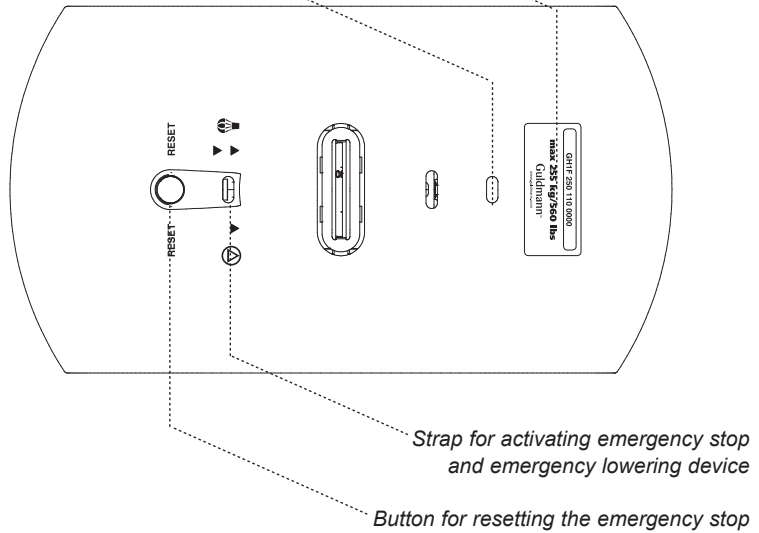

2.01

Pictograms



Emergency stop



Emergency lowering function

RESET

Reset emergency stop



Danger - rotating parts



Release button

**2.02**

**Indicator lamps and audio signals**

Status	Indicator lamps	Audio signals	Possible GH1 F Functions		
			Up	Down	Emergency lowering
Off – stand by	Off				
All OK	Green		✓	✓	✓
Low battery	Yellow		✓	✓	✓
Fault on hoist	Yellow	Beeps at button activation			✓
Battery critical low	Yellow			✓	✓
Over load	Green	Beeps at button activation		✓	✓

**2.03**

**Audio signals**

**Short, consecutive audio signals**

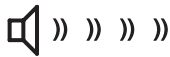

GH1 F's installation function has been activated.

**Long, continuous audio signal**

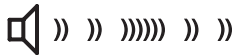

The installation/deinstallation sequence has been interrupted or completed.

## 2.04

### Operation

The GH1 F is switched on automatically when a button on the hand control is pressed.

The GH1 F is switched off automatically after approx. 8 minutes without activation.

### Hand control

The hand control for GH1 F is used to control the following functions:

1. Installing and deinstalling the lifting module

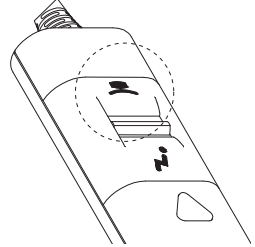

2. Lifting and lowering a person

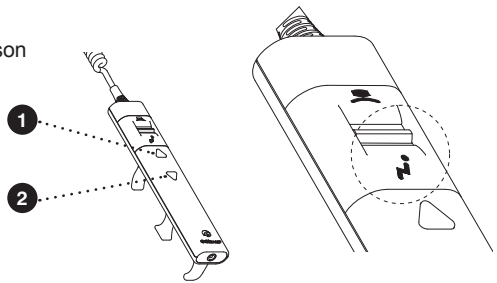

Lift / installing (1)

Lower / deinstalling (2)

**Note:** There must be a load on the lifting strap corresponding to the weight of Goldmann's lifting hanger before GH1 F's lowering function will operate.

The lifting/lowering function will be switched off if the emergency stop/ emergency lowering system is activated (point 3.01).

3. GH1 F is charged with the help of the DC connection on the hand control.

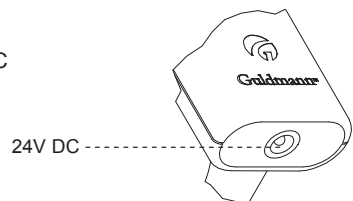

### Charging / connection

GH1 F charges when the plug from the power supply is connected with the hand control. The plug shall always be placed in the hand control when the GH1 F is not in use. This ensures that the GH1 F always functions and is ready for use.

The Power Supply shall be connected before charging through the hand control can take place. A green diode at the power supply indicates that it is plugged in and switched on.

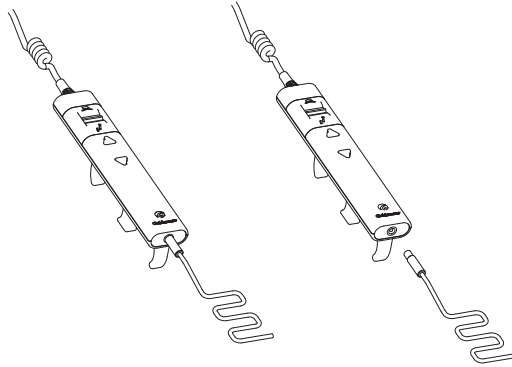

The indicator lamp on the bottom of the hoist turns yellow if the charge status becomes low. The GH1 F then has a limited number of lifts available at a time and must be recharged.

### Placing of the hand control

The hand control can be placed on the hanger bar if necessary in connection with storage or transfer.

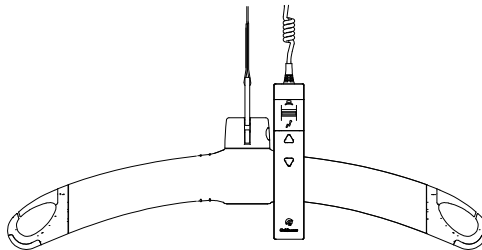



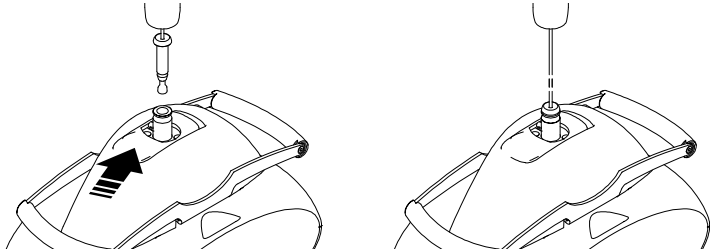

**Preparation, installation**

Place the transport trolley containing GH1 F vertically beneath the travelling trolley in the rail system. Check that there are no obstacles of any kind between GH1 F and the travelling trolley.

1. Attach the travelling trolley's anchor with cord to the locking mechanism on the top of GH1 F.





2. Choose the function "Installation" with the help of the switch at the top of the hand control  (  » » » » )
3. Installation will start by activating the hand control, by shortly pressing the button up 
4. Installation has been completed when GH1 F is automatically locked in the travelling trolley (  » » » » » » » » )
5. Move the switch at the top of the hand control to position to complete installation 

We recommend steering/guiding GH1 F with the hanger so that it is free from the transport trolley during installation

The GH1 F lifting module must not be allowed to swing from side to side during installation.

## Deinstallation

Where applicable, remove the lifting sling from the lifting hanger.  
Place the transport trolley beneath the travelling trolley in the rail system.  
Check that there are no obstacles of any kind between GH1 F and the transport trolley.

1. Lift the strap with the hanger towards the end stop on GH1 F
2. Choose the function "deinstallation" with the help of the switch at the top of the hand control  (  » » » » )
3. Deinstallation will start by activating the hand control, by shortly pressing the button down 
4. Deinstallation has been completed when GH1 F is on the transport trolley and the movement of the cord has stopped
5. Release the travelling trolley's anchor with cord from the locking mechanism on the top of GH1 F.

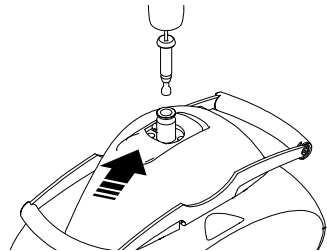

6. Move the switch at the top of the hand control to position 

We recommend steering/guiding GH1 F with the hanger into position on the transport trolley during deinstallation.

### **Please note**

All deinstallation must be begun by briefly moving GH1 F (1-2 seconds) in an upward direction.

It is not possible to begin the installation and/or deinstallation sequence for GH1 F when the load on the lifting strap exceeds the standard weight of the lifting hanger, e.g. if a person is sitting in the lifting sling.

For the same reason a bath chair, a bath stretcher, Horizontal Hoist BS, and the cross lifting hanger must be removed before installing/deinstalling GH1 F.

The installation/deinstallation function will be switched off if the emergency stop/emergency lowering function is activated (point 3.01).



---

**2.07****Lock, Travelling trolley for GH1 F**

The locking mechanism/clutch on the travelling trolley is automatic and changes between a locked and an unlocked state. It changes states each time it is activated.

Avoid unnecessary contact with the lock.

Contact the Guldmann Service Team if it appears that the lock may be damaged.

---

**3.00****Transport/running in the rail system**

GH1 F is moved around in the rail system by the helper/assistant.

**Note**

GH1 F may not be exposed to cold / heat shock. For instance do not bring a cold hoist into a warm bathroom or similar.

---

**3.01****Safety functions**

The emergency stop and emergency lowering device should only be used in an emergency. In the event that it is necessary to use the safety functions, the fault must be identified and rectified before the GH1 F is taken into use again. Please contact your supplier.

**Emergency stop and lowering strap**

The red strap has the following functions:

- One pull: Emergency stop is activated.
- Constant pull: Emergency lowering is activated.

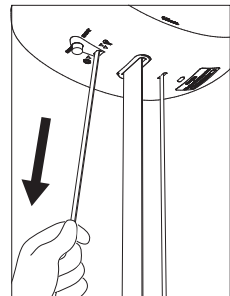
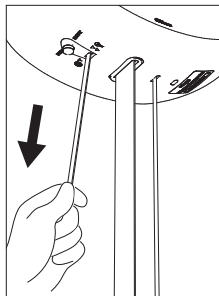
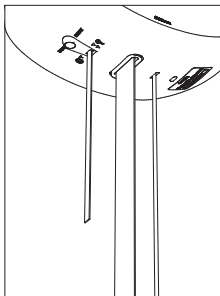

### Emergency stop

If the GH1 F does not stop/react to the hand control when the GH1 F is in use, pull the red strap and the lifting/lowering functions (except emergency lowering) are deactivated.

When the emergency stop is activated, the hoist will not function. The green lamp is switched off.

### Reset emergency stop

Reset the emergency stop by pressing the yellow button on the bottom of the hoist.

The yellow button that appears when the emergency stop is pulled, must be pressed manually before the GH1 F is ready for use.

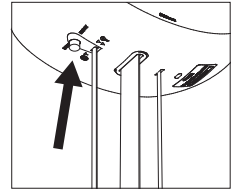

### Emergency lowering function, electric

If the GH1 F fails, the electrical emergency lowering function is used to lower the user safely. The emergency lowering function is operated by a constant pull on the red strap that is used for the emergency stop.

When releasing the red strap, the emergency lowering function will be replaced by the emergency stop.



---

## 3.02

### Safety functions, installation/deinstallation

#### Installation/deinstallation

The installation/deinstallation sequence can be interrupted with the hand control at any time:

1. Press (again) UP  to interrupt the installation/deinstallation sequence
2. Press (again) DOWN  to interrupt the installation/deinstallation sequence

The installation sequence will be automatically interrupted if GH1 F meets an obstacle/resistance ( $\geq 5\text{-}10\text{ kg}$ ) while being moved to the travelling trolley in the rail system, for instance when blocked by a foreign body during installation.

If this happens, GH1 F will stop briefly and then move freely in the direction of the travelling trolley.

#### Resuming installation/deinstallation

When the obstacle has been removed, the installation or deinstallation sequence can be resumed, cf. point 2.05.



Activation of the emergency stop results in an interruption of the installation sequence



Activation of the emergency lowering results in an interruption of the installation sequence

### 3.03

#### Installation lock

It is a condition for carrying out installation and deinstallation that the anchor is attached to GH1 F. The anchor is attached/released with the help of the push button on the top of GH1 F (1).

#### **Important/precaution**

The installation lock may only be operated/released when GH1 F has been deinstalled and placed on a firm surface, e.g. the transport trolley for GH1 F. The deinstallation sequence must have been completed before the installation lock is released. This means that the movement of the cord must have stopped and the installation motor must be inactive.

#### **Attachment to the installation lock**

- Push in the button (1)
- Attach the anchor with the cord from the travelling trolley
- Release the button and check that it returns fully to its original position

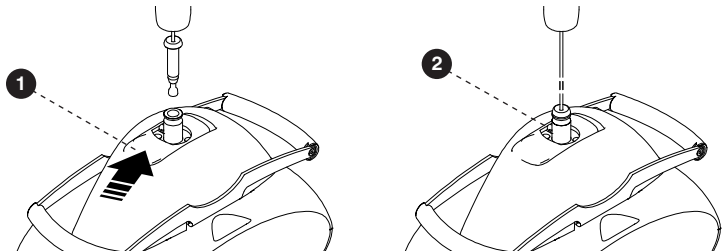

#### **Releasing the installation lock**

- Wait for deinstallation to end and until GH1 F has been placed on a firm surface, such as the transport trolley for GH1 F
- Push in the button (1)
- Release the anchor with cord from GH1 F

Place the anchor with cord at a suitable height beneath the travelling trolley.

#### **Installation protection**

There is a sensor/switch on top of GH1 F, which has a safety function (2). The hand control will be switched off when the sensor/switch is activated.

Avoid unnecessary contact with the sensor.

Contact the Guldmann Service Team if it appears that the sensor has been damaged.

**Transport trolley for GH1 F**

The transport trolley is used to transport and store GH1 F with lifting accessories. There is a specially sewn bag at the bottom of the transport trolley to store lifting slings, the GH1 F power supply, and the manual. The bag can hold up to three lifting slings, depending on the type in question.

The power supply can be placed in the front pocket of the bag.

The cross lifting hanger can be hung from the hooks at the front of the transport trolley. Remove the lifting strap from the cross lifting hanger before installation/deinstallation.

The bag can be removed and washed if it is dirty. Follow the washing instructions on the bag. If necessary, contact your supplier to order a new bag if the old one is worn or damaged.

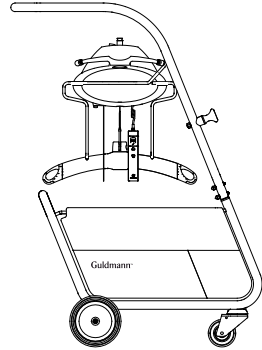
**Note**

We recommend lifting the lifting strap/lifting hanger towards the end stop on GH1 F before placing it on the transport trolley. This will protect the lifting strap against unnecessary wear during transport and while stored on the transport trolley.

**Guldmann – Lifting slings and hangers**

Obtain a product catalogue from Guldmann, or see our product range at [www.guldmann.com](http://www.guldmann.com) where it is also possible to watch a video about the use of lifting slings and to download user manuals for our products.

### Switch track, electrical

A switch track can be used in rail systems where it is used to change direction.

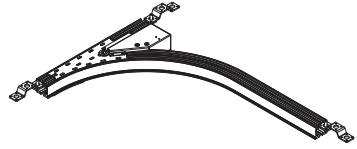

### Turntable

The turntable is used in rail systems where the hoist needs to run in several directions.

The GH1 F hoist is placed in the center of the turntable. By pressing the switch, the turntable rotates 90°. Press again, and the turntable returns to the first position.

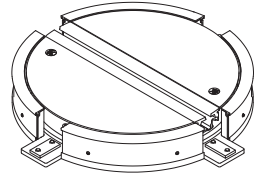

### Safety

This product is mechanically protected against derailing and jamming.

### Combi-lock, manual and electric

The Combi-lock is used when a single track rail system is to be linked up to a room-covering rail system, or when two room-covering rail systems need linking.

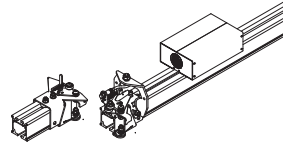

The Combi-lock ensures that the two systems are locked together in situations such as transfer from a single track rail system in a bedroom to a room-covering system in a bathroom.

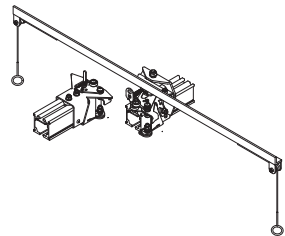

The Combi-lock is available as an electric or a manual model. It is activated by either pressing the switch or pulling on the cord.

### Safety

This product is mechanically protected against derailing and jamming.

### Battery

NiMH Battery 24V/2800mAh, Guldmann type number 550574.

---

## 5.00

### Transport and storage

Guldmann recommends that the GH1 F is always transported and stored in the original packaging.

#### Key to symbols on the GH1 F packaging:



-10 → 40°C    30 → 70%    700 → 1060hPa  
14 → 104°F

The GH1 F should be stored at:

- Temperatures between -10 and +40°C / 14 and 104°F
- A relative air humidity of between 30 and 70 %
- An air pressure of between 700 and 1060 hPa
- This side up

---

## 6.00

### Maintenance and storage

---

#### 6.01

#### Cleaning

We recommend that the product and the parts that patients and caregivers can come in contact with are cleaned with Novadan Des Wipes or Novadan Desinfect O.

**Desinfect O:** A broad-spectrum disinfectant system as tablets. Suitable for disinfection of equipment, tools and surfaces in the healthcare sector.

**Novadan Des Wipes:** Is a disposable wipe for cleaning and disinfection of all types of surfaces, machines and instruments in the healthcare sector.

**NB:** Do never clean the GH1 F, hanger, trolley or rails with strong acid, base or alcohol. Never clean the GH1 F in an autoclave.

Desinfect O is effective against:	Novadan Des Wipes is effective against:
<i>Microbial- &amp; Virus test</i>	
<ul style="list-style-type: none"> <li>• Staphylococcus aureus (ATCC 6538) (EN 13697:2001)</li> <li>• Enterococcus hirae (ATCC 10541) (EN 13697:2001)</li> <li>• Escherichia coli (ATCC 10536) (EN 13697:2001)</li> <li>• Pseudomonas aeruginosa (ATCC 15442) (EN 13697:2001)</li> <li>• Candida albicans (ATCC 10231) (EN 13697:2001)</li> <li>• Swine plague - Bovine viral diarrhea virus (BVDV) (EN 14675:2006)</li> <li>• Swine and avian flue (Influenza A virus H1N1) (EN 14675:2006)</li> </ul>	<ul style="list-style-type: none"> <li>• Staphylococcus aureus</li> <li>• Escherichia coli</li> <li>• Proteus mirabilis</li> <li>• Pseudomonas aeruginosa</li> <li>• Candida albicans</li> <li>• MRSA</li> <li>• H1N1</li> <li>• HBV (HIV)</li> <li>• HCV</li> </ul>

Novadan product	Description	Microbial and Virus test	Application	Dosing	Frequency
Desinfect O	A broad-spectrum disinfectant system as tablets.	Staphylococcus aureus, Enterococcus hirae, Escherichia coli, Pseudomonas aeruginosa, Candida albicans, Swine plague - Bovine viral diarrhea virus (BVDV), Swine and avian flu. (Influenza A virus H1N1)	Tools apparatus (Remember to wash afterwards)	1 tablet –10 l of water  Time before effect: 5 min.	Daily/ periodically
Novadan Des Wipes	Is a disposable wipe for cleaning and disinfection of all types of surfaces, machines and instruments within the health-care sector and food industry.	Staphylococcus aureus, Escherichia coli, Proteus mirabilis, Pseudomonas aeruginosa, Candida albicans, MRSA, H1N1, HBV (HIV), HCV	Lifting pool with adjustable handle, bed guard, remote control of beds, extension piece for bed guards, handle, polyester line for lifting pool.	Time before effect: 1 min.  Apart from H1N1: 30 min	After every touching

---

**6.02**            **Storage**  
See 5.00  
For long-term storage of GH1 F the emergency stop must be activated. This ensures that the battery is not being discharged.

---

**6.03**            **How to prevent/avoid corrosion?**  
When the GH1 F is mainly used in a corrosive environment, e.g. swimming pool, the hoist must be ordered with a special corrosion-preventive surface treatment.

---

**6.04**            **The owner's daily maintenance duty**  
Check the lifting sling for wear and damage before use.  
Do not use the lifting sling if it is damaged or defective.  
Do not use GH1 F if the lifting strap or the rubber safety catch of the lifting hanger are damaged or defective.  
Contact your supplier and order a new lifting sling or a replacement of the lifting strap. Replacement of the lifting strap must only be performed by the Guldmann Service Team or by a qualified technician in accordance with Guldmann's instructions.

---

**6.05**            **Disposal of the GH1 F including battery**  
Local and national regulations on environmentally correct recycling must be observed. Batteries (type NiMH) must always be delivered to an approved recycling point.

---

**7.00**            **Service and lifetime**

---

**7.01**            **Lifetime**  
The GH1 F has an expected lifetime of 15 years, on the condition of correct use and correct service inspections, see section 7.02.

**Replacement of components**  
Replacement of batteries, PCBs and lifting straps must be performed by a qualified service technician or the Guldmann Service Team.



---

**7.02****Safety/service inspections**

In accordance with international standard EN/ISO 10535 "Hoist for the transfer of disabled persons – Requirements and test methods" an inspection should be performed on the hoist at least once a year.

Guldmann recommends that regular safety/service inspection is performed at least once a year with regard to the pattern of usage.

Inspection of the GH1 F must be performed by a qualified service technician or the Guldmann Service Team.

In connection with the purchase of the GH1 F, Guldmann or your supplier may offer a service agreement for this inspection.

During the safety/service inspection a report must be prepared on what was checked and replaced. Parts that are worn or defective must be replaced with new parts from Guldmann. Spare parts drawings and documentation can be obtained from the manufacturer or supplier.

**Documentation/checklist regarding safety/service inspection can be obtained from the manufacturer or supplier.**

---

**7.03****Service inspection, travelling trolley for GH1 F**

Deinstall GH1 F and put it on the transport trolley before service inspections of the Travelling trolley for GH1 F are carried out.

**1. Visual control of the trolley**

- Check for wear, irregularities, or other types of damage to the hoist

**2. Remove cover/screen**

- Clean the trolley to remove dirt and other impurities
- Inspect and evaluate vital parts

Every second year or after 2000 installations:

- Dismantle the complete locking and winding mechanism
- Install new, complete Quick lock (spare part)

**3. Replace cover/screen****4. Adjust the length of the cord in relation to the height of the rail****5. Carry out installation and deinstallation of GH1 F**

- Check all product functions

**6. Have new problems arisen or been found under item 5?**

- If new problems have arisen, return to item 2
- If there are no new problems, the service inspection has been completed

**7. When a service inspection including service work or exchange of components has taken place, the final check must comprise a weight test with the product's nominal load.**

---

**7.04****Trouble-shooting, GH1 F**

GH1 F lifting/lowering functions fail to respond when the hand control's up/down keys are pressed.

- Check that the emergency stop/emergency lowering device have not been activated
- Check that the hoist's indicator lamp is green when activating the hand control (see section 2.04).

**Is the product installed in the travelling trolley/rail system?**

If NO

- Contact the Guldmann Service Team  
The hand control may be defective

If YES

- Contact the Guldmann Service Team  
GH1 F may have been incorrectly installed

**The GH1 F does not respond to the hand control's keys**

1. Check that the emergency stop is not activated (*see section 3.01*).
2. Check that GH1 F has power supply and that the battery is recharged (*see section 2.04*).
3. Check that the power supply is on and connected to the hand control.
4. Charge GH1 F. (*see section 2.04*).
5. Contact the Guldmann Service Team if the fault cannot be found and corrected

---

**7.05****FAQ's**

Can GH1 F be installed/deinstalled while a person is sitting in the lifting sling?

No – GH1 F measures the load on the lifting strap before installation/deinstallation. If the load exceeds the weight of the lifting hanger, the sequence for installation/deinstallation cannot be activated.



CE-marking



Type B in accordance with IEC/EN 60601-1



Read the manual before use



Must not be disposed of as standard household waste, must be recycled.

Class 2 equipment . . . . . Non-permanent installation without protective ground

The equipment is not suitable for use in the presence of flammable mixtures.

**Degree of protection against harmful ingress of liquids (water)**

Lifting module. . . . . IP 20

Hand control. . . . . IP 42



## Examples of labels

### Lifting module

**GH1 F 205 114 0000**

**max 205 kg/450 lbs**

Part no. xxxxxx  
 Prod. date yyyy-mm-dd  
 Serial no. xxxxxx

33V AC, 2.5 A, IP44  
 CONTINUOUS OPERATION  
 WITH SHORT-TIME LOADING

INTERNALLY POWERED  
 EQUIPMENT 24V DC

**Guldmann™**  
 www.guldmann.com

Barcode 128C

**GH1 F 205 114 0000**

**max 205 kg/450 lbs**

**Guldmann™**  
 www.guldmann.com

### Power supply

**SINPRO**  
 SWITCHING POWER SUPPLY  
 MODEL NO.: HPU31B-110  
 INPUT: 100-240V ~ 47-63Hz  
 0.6-0.4A  
 OUTPUT: 36V 0.83A max





Indoor use only





E 230351



Efficiency Level





EN 60601-1  
 IEC 60601-1

アビリティーズ・ケアネット株式会社

**CAUTION**  
 DO NOT OPEN  
 RISK OF ELECTRIC SHOCK  
 ATTENTION  
 NE PAS OUVRIER

RoHS XX MADE IN

### Lifting hanger

**max**  
**xxx kg/xxx lbs**

Part no. xxxxxx  
 Edition xxx  
 Prod. date yyyy-mm-dd  
 Serial no. xxxxxx

Barcode 128C

V. Guldmann A/S  
 www.guldmann.com

### Hand control

Part no. xxxxxx  
 Edition xxx  
 Date xxxx-xx-xx  
 IP44

9.00

Technical specifications

GH1 F Lifting modules, configurations									
Guldmann hoist type	Product line	Load in kg	Number of lifting straps	Number of lifting motors	Additional functions	Scale module	CLM module	Service module	User interface
GH1	(x)	xxx	x	x	x	x	x	x	x
GH1	F	175	1	1	4				0
		205	1	1	4				
		255	1	1	4				

**Example: GH1 F 205 114 000**

GH1	F	205	1	1	4	0	0	0	0
-----	---	-----	---	---	---	---	---	---	---

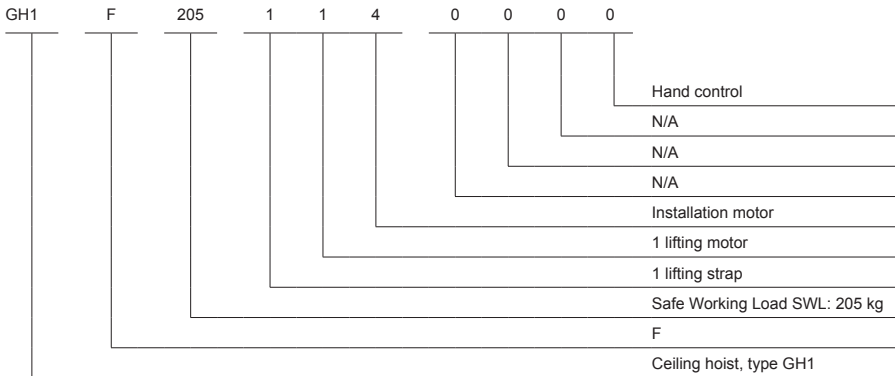

### Functions

Lifting capacity, SWL . . . . 175 kg (385 lbs), 205 kg (450 lbs), 255 kg (560 lbs)  
Operation . . . . . Hand control  
Sound level . . . . . 52 dB (A)

### Lifting speed

85 kg (187 lbs) load . . . . . 40 mm/sec.  
150 kg (330 lbs) load . . . . . 40 mm/sec.  
Max capacity load, SWL . . . . . 40 mm/sec.  
Max. 5 kg (11 lbs) load . . . . . 80 mm/sec.

### Weight and materials

SWL . . . . . 175 kg (385 lbs), 205 kg (450 lbs), 255 kg (560 lbs)  
Hoist . . . . . 11.0 kg  
Hoist including trolley . . . . . 12.2 kg

Covers, top and bottom . . . . . shock-proof UL 94 V-O fire-resistant  
recirculates plastic

### Dimensions

A . . . . . 530 mm  
B . . . . . 350 mm  
C . . . . . 230 mm  
D . . . . . 330 mm  
E . . . . . 83 mm  
F . . . . . 580 mm  
G . . . . . 2500 mm  
Depth of hoist . . . . . 194 mm

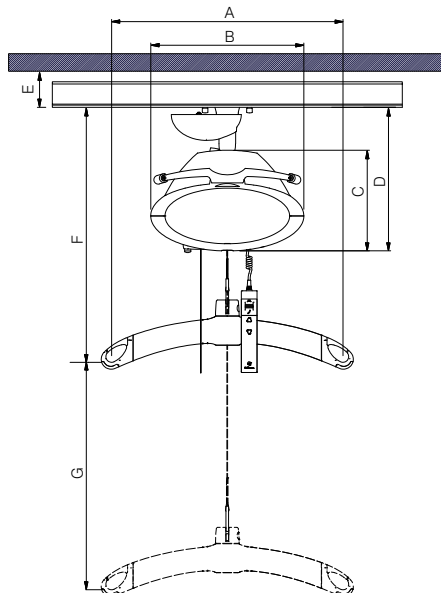

## Safety

Emergency stop	Yes
Emergency lowering device	Yes, electrical
Control of lifting strap	Yes
Cut-off angle	.45° along the rail 10° across the rail

## Electronics

On/off	Automatic when used. Soft start/stop
Overload protection	Automatic
Low battery protection	Automatic
Power supply	36 V DC, 0.83 A
Supply voltage	100-240 V AC, 47-63 Hz

Battery	24 V NiMH
SWL: 175 kg (385 lbs), 205 kg (450 lbs), 255 kg (560 lbs)	2.8 Ah

Continuous operation with short time loading with 3 hours without recharging	10/90 % (2 min. operation/18 min. pause)
---	--

Max number of lifts in series with:

85 kg (187 lbs)	55/1000 mm
175 kg	44/1000 mm
205 kg	36/1000 mm
255 kg	28/1000 mm

Max charging time at 25°C (77°F)	3 hours
----------------------------------	---------

Operating temperature	10°C - 35°C (50°F - 95°F)
-----------------------	---------------------------

## Degree of protection against harmful ingress of liquids (water)

Lifting module	IP 20
Hand control	IP 42

### Travelling trolley for GH1 F

A	98 mm / 3.5"
B	166 mm / 6.5"
C*, max.	2800 mm / 110"
D, min.	650 mm / 25.5"
D, max.	750 mm / 29.5"
Depth of travelling trolley	84 mm / 3"

\*Cord length C adapted to height of rail during installation

Max. load . . . . . 255 kg / 560 lbs.

Weight:

Travelling trolley (with the exclusion of lifting modules GH1 F) . . . . . 1.2 kg / 2.5 lbs.

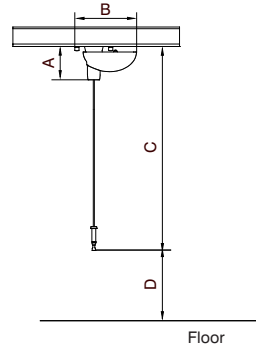

### Transport trolley for GH1 F

A	1005 mm / 39.5"
B	735 mm / 29"
Depth of transport trolley	485 mm / 19"

Capacity, bag . . . . . 2-3 slings

. . . . . 2-3 lifting hangers

Capacity, max . . . . . 25 kg

Weight:

Trolley including bag . . 10.4 kg / 23 lbs.

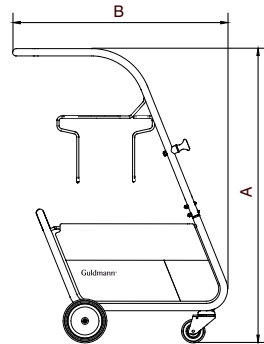

## 10.00

### EC-Declaration of conformity

The products are manufactured in compliance with the Council Directive 93/42/EEC of 14 June 1993 – with amendments, as medical device class 1.



## USA and countries outside the EU

---

### A. **Users guide**

Before using the product, read the entire operation manual including warranty.

---

### B. **WARRANTY**

Guldmann warrants its equipment is free from material defects under normal use, and will perform substantially in accordance with the specifications set forth in documentation provided with the equipment.

This express warranty shall be in effect for one year from the date of original purchase and installation (the "Warranty Period"). If a valid claim is made during the Warranty Period for malfunction or equipment defect, Guldmann will repair or replace the equipment at no additional cost to you. Guldmann retains sole discretion as to whether the equipment will be repaired or replaced.

This warranty shall be null and void if the equipment is operated and maintained in any manner inconsistent with its intended use or the instructions provided with the product. Further, in order for the warranty to remain in effect for the full Warranty Period, all service to the equipment must be provided by a Guldmann designated technician. Any parts or components repaired or replaced by a Guldmann designated technician will be guaranteed for the remainder of the Warranty Period.

The warranty does not cover any part of the equipment which has been subject to damage or abuse by the user or others. The warranty does not cover any part of the equipment which has been altered or changed in any way by the user or others. Guldmann does not warrant that the lifting device functions will meet your requirements, be uninterrupted or error free.

The warranty set forth is in lieu of all other express and implied warranties, whether oral, written or implied, and the remedies set forth above are your sole and exclusive remedies. Only an authorized officer of Guldmann may make modifications to this warranty, or additional warranties binding on Guldmann. Accordingly, additional statements such as advertising or presentations, whether oral or written, do not constitute warranties by Guldmann.

#### **Service or Repair**

Contact Guldmann Repair for an authorization to return any defective item during the Warranty Period. You will be provided with a return authorization number and address for returning the item for warranty service or replacement. Do not return items to Guldmann under warranty without receiving a Return Authorization Number.

If mailing the item, pack it carefully in a sturdy carton to prevent damage. Include your Return Authorization Number, a brief description of the problem and your return address and phone number. Guldmann does not assume the risk of loss or damage while in transit, so it is recommended you insure the package.





| Time to care |

**V. Guldmann A/S**

Corporate Office:  
Graham Bells Vej 21-23A  
DK-8200 Aarhus N  
Tel. +45 8741 3100  
Fax +45 8741 3131  
info@guldmann.com  
www.guldmann.com

**Guldmann Inc.**

14401 McCormick Drive,  
Unit A  
Tampa, FL 33626  
Tel. 800 664 8834  
Tel. 813 880 0619  
Fax 813 880 9558  
info@guldmann.net  
www.guldmann.net