



XTZ 99 W12.18 P
Passive High End subwoofer

User manual

© 2009 XTZ AB , www.xtz.se

Table of contents

	Page:
Contents	3
About XTZ	3
Technical presentation	4
Preparations	4
Practice of sound / Installation and placement tips	5
Mounting	7
Area of usage	8
Technical specifications	9
Service & Support	10

Contents

Contents

Congratulations of your purchase the 99 W12.18P

When combined with surround audio/video electronics, you will experience sound of motion pictures or music records much deeply and naturally. Now when you watch your favourite movie or listen to your reference music CDs, you will hear and feel the sound surrounding you in the same way as originally intended by mastering engineers.

XTZ 99 W12.18P is a passive subwoofer, which means that an amplifier is needed for power the woofer.



Read the manual before using the product and use all possibilities carefully.

About XTZ

Philosophy

Our reference and starting point is to recreate a natural sound, taking into account that acoustics always is a matter of taste.

XTZ Goal

Our main goal is to provide the best value for money.

Our concept:

- Cut down the numbers of middlemen
- Put more money on product quality and less on advertising.
- Manufacture cost-effective in large volume
- Provide perfect technical solutions

Contact

Website: www.xtz.se

E-mail: info@xtz.se

Technical presentation

Amplifier	The W12.18P is a passive woofer, so an external amplifier is a need. 100-400 Watt is appropriate power.
The woofer/ driver	<p>We have chosen a 12 inch woofer from (in this field famous) the Danish/American company Tymphany. The woofer is a Peerless XXLS 12 (Xpanded Extra Long Stroke). The construction has been on the market for many years. This updated version is one of the best 12" woofers on the market. With an extremely stiff and stable injection moulded metal basket to keep the critical components in perfect alignment. Large windows in the basket both above and below the spider reduce sound reflection, air flow noise and cavity resonance to a minimum.</p> <p>The extremely stiff aluminium cone gives tremendous bass precision.</p> <p>The cone and the low loss rubber surround show no sign of the familiar cone edge resonance and distortion associated with soft cones.</p>
The cabinet	The cabinet is made of 21mm MDF with 4 stays which makes the box stable and without resonances.

Preparations

Unpacking the subwoofer	Carefully unpack the speaker, and pay attention so you don't break anything. If possible, save the packing box for future transportations. If there should be damage on the loudspeaker, please contact your retailer.
Accessories	2 bass plugs (found in the bass reflex gates) User manual Speaker cover

Practice of sound / Installation and placement tips

This chapter contains common information on loudspeaker placement and installation.

This is general rules, so there are exceptions of some rules

In which room do you achieve the best sound?

No matter how good the equipment is, in the wrong listening environment it will inevitably sound bad. There are some basic rules concerning a proper loudspeaker installation:

Reflections

Carpets, curtains and soft furniture absorb mid range and high frequency sound, and this is preferable. Big empty area, on the contrary, reflects it and produces hard reflections that may lead to blurry dialogue. Apart from colouring the sound, also the perspective of the sound will deteriorate. Reflections in the room can roughly be compared to the reflections that yield ghost pictures on a TV screen.

Amplification of bass frequencies

A loudspeaker that is placed near a wall, ceiling or floor will amplify lower frequencies in a sometimes not desirable way (since it may lead to an indistinct sound recreation). This amplification becomes even more obvious if the loudspeaker is placed near a corner. Thus, for a sound as clear as possible, the loudspeaker should be placed at least 30 cm (about 12 inch) away from the wall

Some constructions are made to be placed closed to a wall.

Furniture

Be aware that furniture may vibrate and thus create bad sound at loud bass.

Room dimension

Quadratic rooms or rooms where the length is exactly twice as long as the width should be avoided, since they may create unwanted resonance.

Placement of the subwoofer

The placement of the subwoofer in the room dramatically affects the overall frequency response and sound level of the system. At low frequencies the effect of the room is strong. Even a slight change in the subwoofer's location can make a significant difference in the frequency balance. Patience and methodical experimentation is needed to find an optimal placement. The placement affects the phase difference between the main loudspeakers and the subwoofer.

One basic rule is to place the subwoofer together with or near the front system (especially important if the front loudspeaker also propagate bass frequencies) as this will minimize the risk of phase eliminations in the room.

Cables

Try to keep them as short as possible. By its electrical parameters, a long conductor will have a bigger influence on the sound than a short one. It may also work as an antenna and thus receive various signals that may become a constant noise in an active subwoofer.

Make sure that all connections are clean and not oxidized. All connections should be mechanically stable, both power, signal and loudspeaker cables. Signal cables should be separated from other cables.

Front speakers

To get the best result the front speakers should be placed symmetrical in front of the listener. The distance between the front speakers should be around 80% of the distance to the listener. In other words, the recommended angle between the front speakers should be 45° .

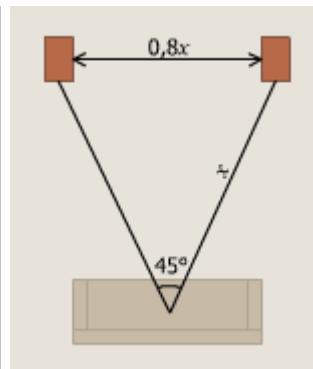

Why use 2 Subwoofer

There are more than one benefits of having 2 subwoofers instead of one.

The sound pressure level will be higher.

Less dips and standing waves in the room and a better frequency response in the room (and on sweet spot)

The need of power is less, to reach the same SPL as with one subwoofer

Finally

Please remember that good sound is a matter of taste, so you have to experiment to obtain your favourite one.

We wish you best of luck!

Mounting

Mounting

Generally:
The placement of the subwoofer in the room affects the overall frequency response and sound level of the system dramatically, as at low frequencies the influence of the room is strong.

Even a slight change in the subwoofer's location can make a significant difference in the frequency balance, and often patience and methodical experimentation is needed to find the optimum placement.

This subwoofer is intended for XTZ products, but can of course be used with other speakers.

Spikes

99 W12.18P have feet of rubber to absorb vibrations. But it's possible to change this to spikes.

The Rubber foot are adjustable to get the subwoofer in level with the floor. The foot are removable for those who want to mount spikes. (M6 screw)

Connect with the correct phase

Always connect using the correct phase, from the +-pole on the amplifier to the +-pole on the loudspeaker and respectively for the minus (-) pole

If you by accident connect the other way, there is no risk of damage. However, the phase of the signal will be not correct, resulting in improper sound.

Overload

With high power load under long time there is risk of overloading the driver and/or the amplifier.

WARNING!

All products, amplifiers, speakers, cross-overs can be damaged if playing loud music for a long time

The initial playing time

It takes about 50 to 100 hour of initial playing time, for the driver to sound optimally. During this time, the speaker may be used normally.

Area of usage

Connection	Connect the speaker cable to the input of the subwoofer	
Room Tuning - Mechanical adjustment of the boundary frequency	<p>By using the supplied bass plugs in the bass reflex gates, you can alter the lower boundary frequency on XTZ 99 W12.18P. This makes it possible to alter the sonic characteristics of the woofer. The picture below shows 4 basic settings.</p> <p>With 1 or 2 open reflex gates(bass-reflex) will increase the efficiency so it can handle more sound pressure than with 2 closed reflex gates(closed-box)</p> <p>1st mode - no plugs in the reflex gates No plugs in the gates will provide a "quick" bass suitable for big rooms.</p> <p>2nd mode - 2 bass plugs in the reflex gates This will provide a neutral, even and controlled bass setting (Closed box)</p> <p>3rd mode - 1 plug in the right reflex gate One plug in the right gates will provide a "deep" bass suitable for smaller rooms.</p> <p>4rd mode - 1 plug in the left reflex gate One plug in the left gates will provide a a "neutral" bass character.</p>	<p>Since the sonic characteristics depends on the room a whole range of external factors, there exists no "standard" setting for a neutral representation.</p> <p>Room tuning will also have influence on the efficiency you will have to adjust the volume, frequency and High Pass in the room tuning modes.</p> <p>"Quick" bass explained: By this we mean a bass with less deep bass information. This might also be called "hard", "attack", "tight", "punchy" etc.</p>

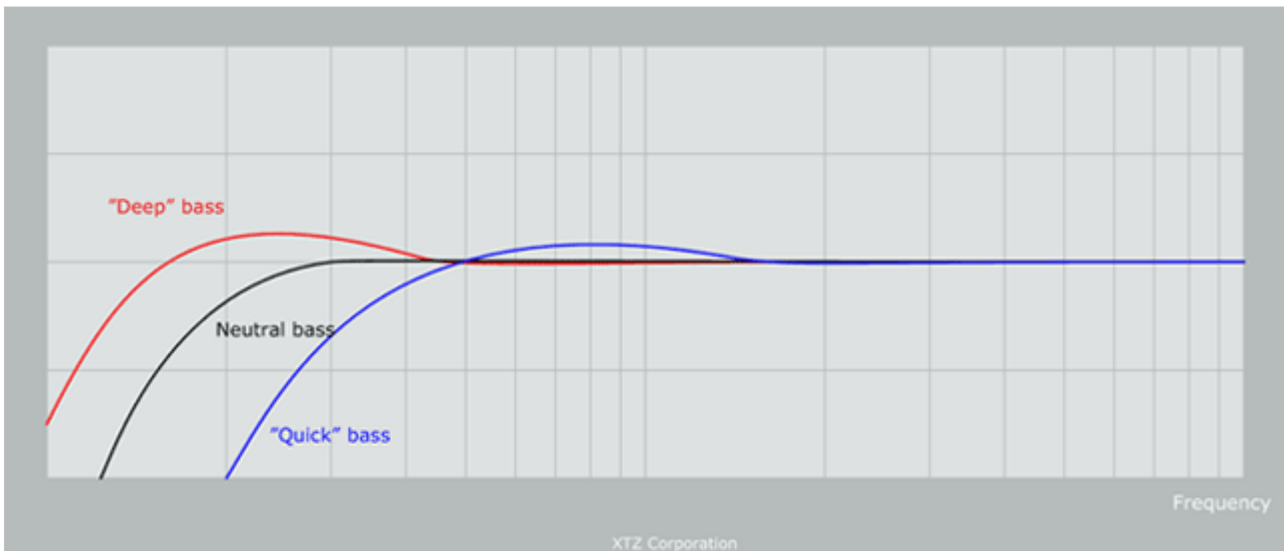

This picture shows not actual measured curves. It is only intended to be used as an illustration on the different acoustic characteristics in the lower frequencies.

Technical specifications

Construction type	Passive subwoofer, Bass reflex gate or may be set as closed box. Room-tuning.	
Dimensions	460 x 394 x 460 mm (HxWxD)	Feet not included
Weight	27,5 kg	
Magnetic shielded	No	
Power handling driver	350 W Short term - IEC 268-5 175 W Long term - IEC 268-5	
Impedance driver	4 ohm	
Driver	12" Peerless XXLS woofer ,Aluminium cone, aluminium frame, High flow basket, 2,2kg magnet. Total weight 6,5 Kg	
Connections.	Speaker input - Gold plated banana plug / pole screw.	

Service & support

Warning!

This subwoofer is capable of delivering sound pressure levels in excess of 85 dB, which may cause permanent hearing damage.

Guarantee

This product is supplied with a ONE year guarantee against manufacturing faults or defects that might alter the performance of the unit. Refer to your supplier for full sales and guarantee terms.

Service

If you need service contact your local dealer. You are always welcome to contact us if you have problems with product by e-mail: **support@xtz.se**

Webpage: **www.xtz.se**

ALWAYS pack the product / part very carefully. Unfortunately damages during transportation are very common. If the package is weak, the transporting company does not compensate damages. Always enclose a copy of the receipt and a description of the defect.

Support

Please contact our “free-of-charge” support if you need installation advice, or if any problems occur during the installation.

Contact us by e-mail **support@xtz.se** and include your phone number if you require help, and we will ring you back.