

# PicoLAS

FOCUSSING POWER TO THE POINT



## User Manual

Rev. 14.07

LDS-VRHSP-02-BF  
BFS-VRM-03-HP  
BFS-VRM-03-LP  
LDS-VR-03

PicoLAS GmbH  
Company for Innovative Power Electronics and Laser Technology

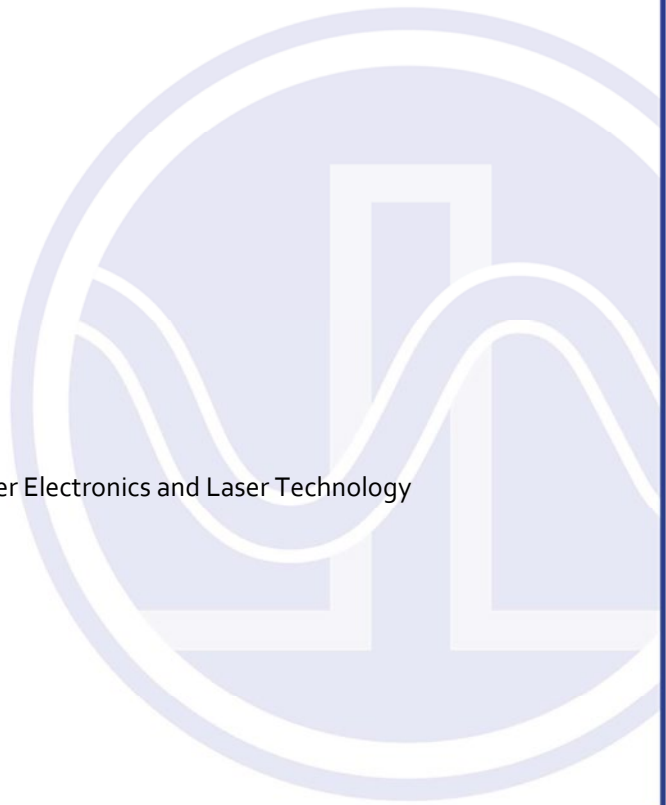

## Table of Contents

Table of Contents.....	2
How to use the Manual .....	3
Absolute Maximum Ratings (destroying limits) .....	3
Dos and Don'ts.....	4
How to get started .....	5
Required Laser-Diode Pinout .....	7
Required electrical characteristics of the Laser-Diode: .....	8
Operation Principle of the BFS-VRM 03.....	9
Description of the Connectors of the BFS-VRM 03 .....	11
Input (#2) and Current Monitor (#1).....	12
Input overdrive (#2) .....	13
Propagation delay (#2 to #1) .....	14
Power Supply (#3) and Supply Absolute Maximum Ratings .....	15
Description of the RS232 Connector (#4) .....	15
How to connect the PLB-21 to the RS232 Connector (#4) .....	16
Description of the I/O Connector (#5) .....	17
Linearity .....	18
Cooling .....	19
Test Load.....	19
TEC Stage .....	19
Laser fire monitoring output (#5-2).....	20
Mechanical Dimensions .....	21
I <sup>2</sup> C Interface .....	23
Controlling the BFS-VRM-03 using a PLB-21 .....	25
Controlling via USB .....	28
The PicoLAS Protocol .....	34

---

## How to use the Manual

 **Remark:** The BFS-VR-03 described in this manual is a base-plate cooled laser diode driver. Improper cooling may cause an internal over temperature shutdown.

**Base plate cooling:** Depending on the final application and operation regime, this unit may stay none-cooled or must be assembled onto a heat sink.

Please refer to chapter Power dissipation for more details about the thermal power losses during operation.

You may use a passively or an actively air/water cooled device.

**Housing:** All units are delivered with housing. Changes are possible; the units can be delivered without housing upon request.

Before powering on your unit, read this manual thoroughly and make sure your understood it fully.

 Please pay attention to all safety warnings.

If you have any doubt or suggestion, please do not hesitate to contact us!

## Absolute Maximum Ratings (destroying limits)

- All Input Pins must not exceed the voltage range below zero (GND) and beyond VCC
- VCC Limit: Refer to table in chapter "Power Supply (#3)"
- Peak TEC-Current: +/- 1.5 A
- Max /UT /OT current: 10mA
- Operating temperature range: + 0 °C .. + 60 °C
- Best performance operating temperature range: + 10 °C .. + 35 °C
- Storage temperature range: - 20 °C .. + 70 °C

### *Dos and Don'ts*

**Never** ground any output connector.



**Do not** connect your oscilloscope to pin no. 10 and pin no. 11!  
This will immediately destroy the driver and the probe!

Keep connecting cables between power supply and driver as well as the connection between driver and laser diode as short as possible.

**Mount the driver on an appropriate heat sink!**



**Please be aware that there might be hot surfaces, be careful not to touch them!**

## How to get started

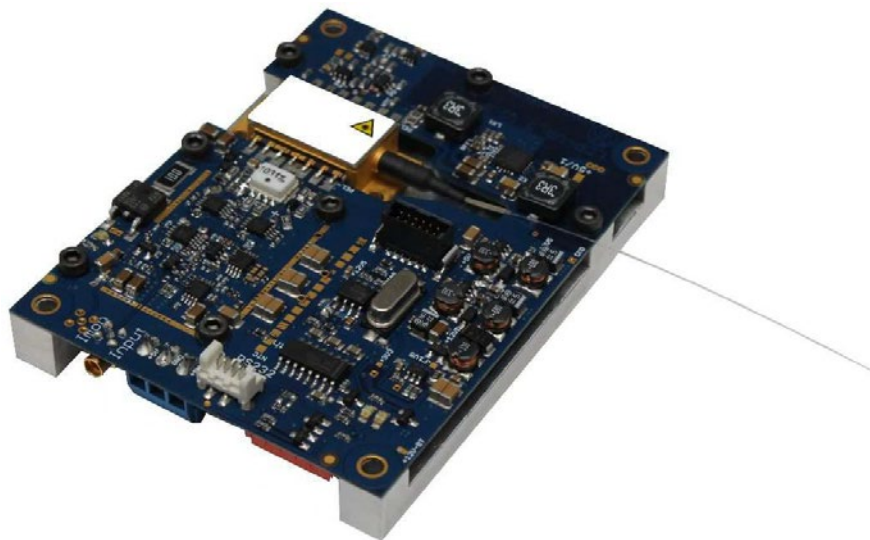

The basic settings (Temperature, BIAS-Current etc.) can be adjusted using the RS232 or the PLB-21. You need an additional fast arbitrary waveform generator (AWG) which has to be connected to the Input MMCX-Terminal. There is no AWG on board of the seed driver!



The PCB is very thin. Mechanical forced have to be avoided to prevent damage. Mechanical damages are not covered by warranty.

Step #	What to do	Check
1	Assemble the driver onto an appropriate heat sink	
2	Solder a dummy-diode between pin no. 10 and pin no. 11, alternatively make a short circuit there.	Refer to Chapter "Test Load"
3	Connect GND, +5V TEC and +5V LD on Power connector (Power Supply disabled).	Required current for this step is around 1.2 A
4	Connect PLB21 via D SUB9 to Micro MaTch cable.	Refer to cable drawings
5	Connect AWG or pulse generator on Input Terminal (no pulse before power supply enabled).	Refer to all chapters referencing Input (Connector #2)
6	If a PLB-21 is used, communication must be possible.	Check the +5V TEC supply for this step
7	Enable the power source for +5V LD and feed a Pulse on the input terminal. For example 0.5 V amplitude 1 $\mu$ s pulse width and 300 $\mu$ s	Make sure not to overload the laser diode or the driver.

	repetition rate.	
8		On Imon-Output (current monitor) you can measure a signal comparable with the input signal. 1 V on the input terminal results a current of 3 A* by test-diode or bypass and 0.6 V on the Imon-Output. Use an oscilloscope with a 50 Ohm termination.
9	<b>Disable the input signal and turn the power sources for +5V LD and +5V TEC of. Take out the test-diode or bypass. Assemble the final laser diode.</b>	
10	<b>Turn the power supply for the +5V TEC on. With a laser diode with TEC on the driver you can take temperature settings on the PLB21.</b>	Use the menu TEC Setpoint → TEC stp.
11	<b>Apply the driving signal.</b>	Make sure not to overload the laser diode!

\* Typical 3 A, guaranteed 2.5 A

### Required Laser-Diode Pinout

The BFS-VRM-03 is designed for the use with Laser-Diodes in a butterfly-package according to the following Pin-Layout:

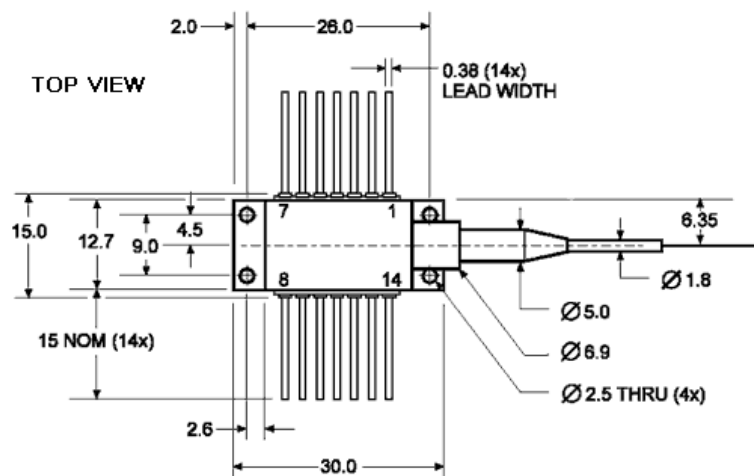
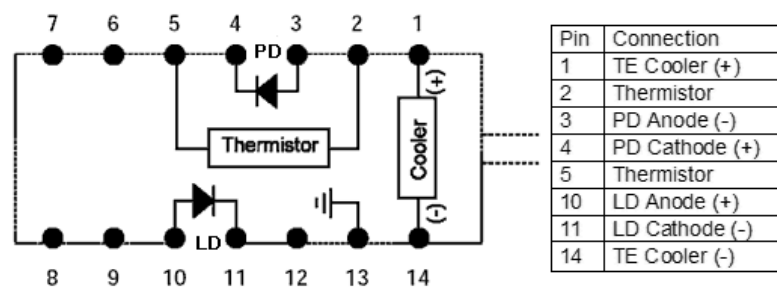

The driver is connecting Pin 9 & 10 and Pin 11 & 12 together.  
Pitch of the legs: 2.5 mm.  
Distance of the legs to bottom of the chassis: 4.5 mm.



Please shorten the legs to avoid short circuits inside the driver



The maximum internal stray impedance must not exceed ~ 10 nH to achieve best performance

**Required electrical characteristics of the Laser-Diode:**

Parameter	Comment	min	typ	Max
Laser Diode Forward Voltage		0 V	1.8 V	2.2V
Back facet monitor reverse voltage			5 V	15 V
Back facet monitor responsivity	5 V reverse voltage	0.5 $\mu$ W/mA		20 $\mu$ W/mA (10 $\mu$ W/mA typ)
Back facet monitor dark current	5 V reverse (bias) voltage			40 Na
Thermistor resistance	At 25 °C	9.5 k $\Omega$		10.5 k $\Omega$
TEC Current	Peak Current (short-term)			2.0 A
TEC Current	Continuous Current	0 A	1.0 A	1.5 A
TEC voltage	Depending on type of Laser Diode			3 V



## Operation Principle of the BFS-VRM 03

### Laser Driver block diagram

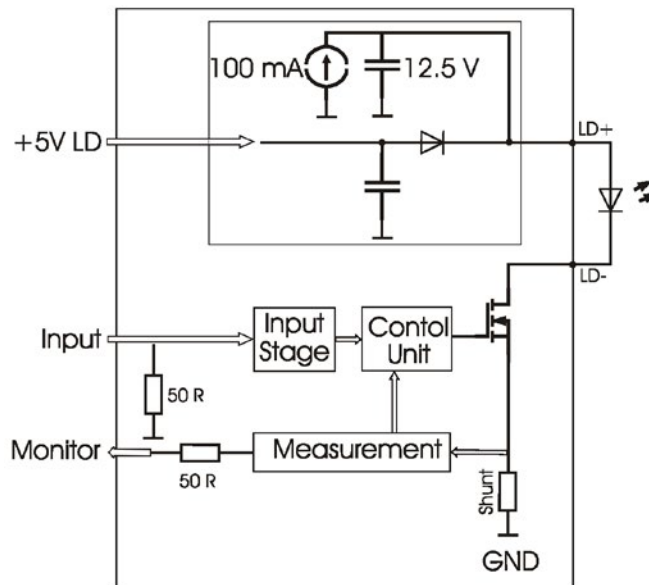

### TEC Driver block diagram

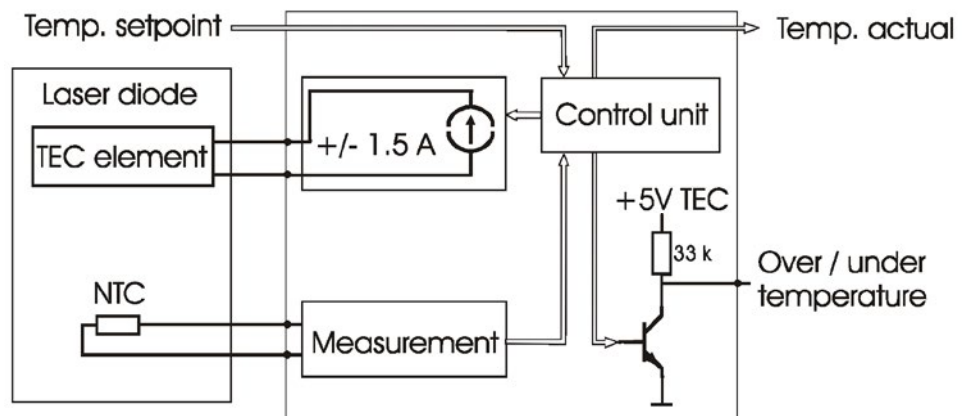

*Laserfire block diagram*

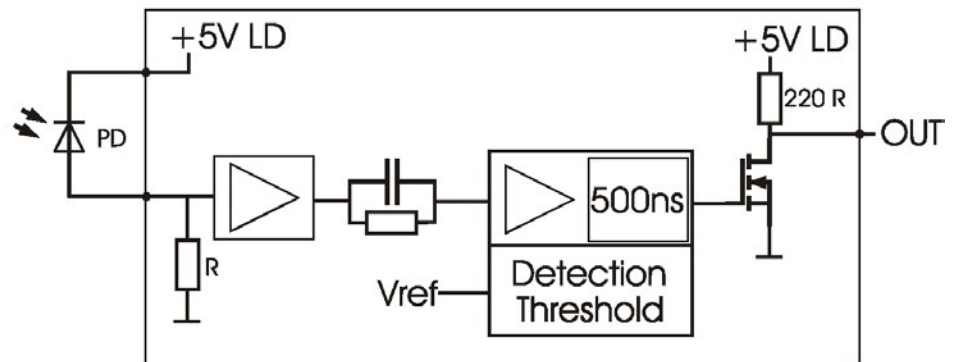

### Description of the Connectors of the BFS-VRM 03

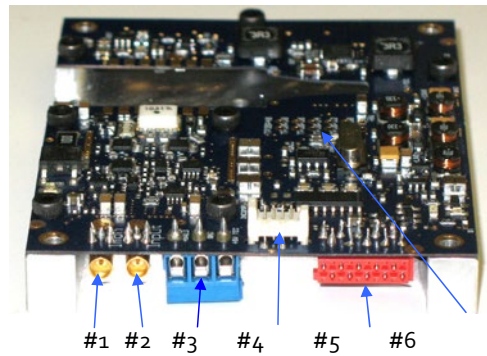

Connector	Function	Assembled Type	You need:
#1	Current monitor (Output)	MMCX, female <sup>1</sup> MOLEX - 73415-1001	MMCX, male (e.g. Farnell 1111325)
#2	Signal-Input	MMCX, female MOLEX - 73415-1001	MMCX male (e.g. Farnell 1111325)
#3	Power connector	Screw terminals <sup>2</sup>	-
#4	RS232	MOLEX_908140004	MOLEX - 90327-0304 (e.g. Farnell 673146)
#5	I/O	Micro-MaTch, female 8-215460-0	Male on Wire 1-215083-0 (e.g. Farnell 1772972)
#6	Programming adapter. Do not use.		

<sup>1</sup> Not assembled for LDS-VRHSP-02-BF

<sup>2</sup> Connector is different for LDS-VRHSP-02-BF

### Input (#2) and Current Monitor (#1)

The driving analogue signal is provided via Connector #2. The output current is following the input signal within the limitations (bandwidth, max. current, rise time) proportional (refer to Chapter "Linearity").

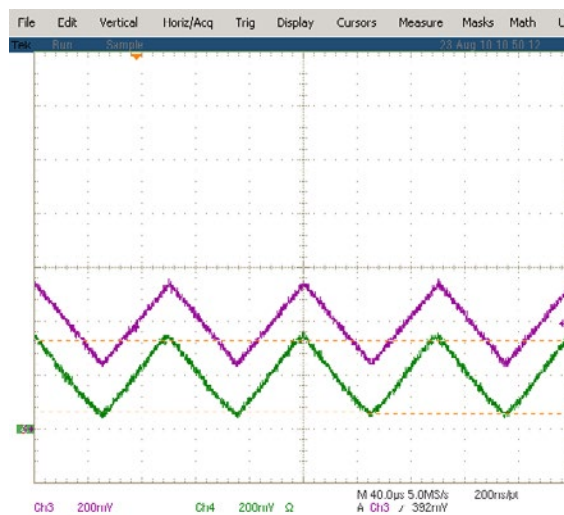
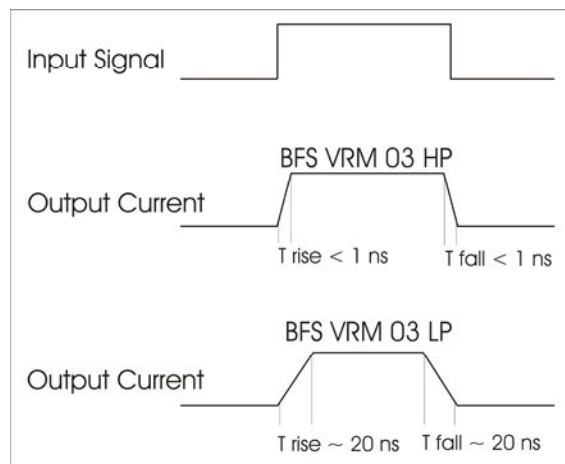



**Input overdrive (#2) Only for BFS-VRM 03 HP**

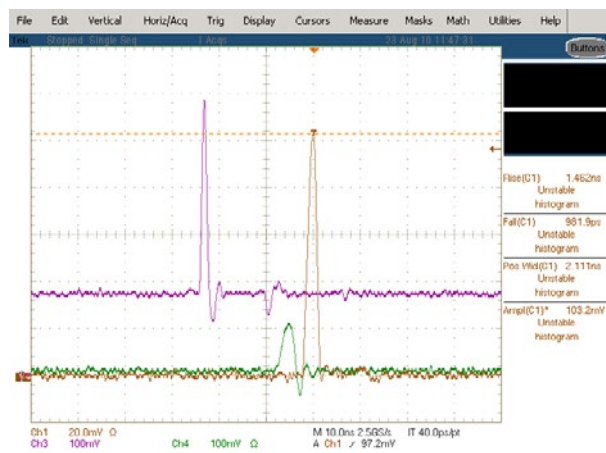

## Propagation delay (#2 to #1)

The typical propagation delay from input to start of current flow is typ. 10 ns. Additional 8 ns appear through the internal current monitor.

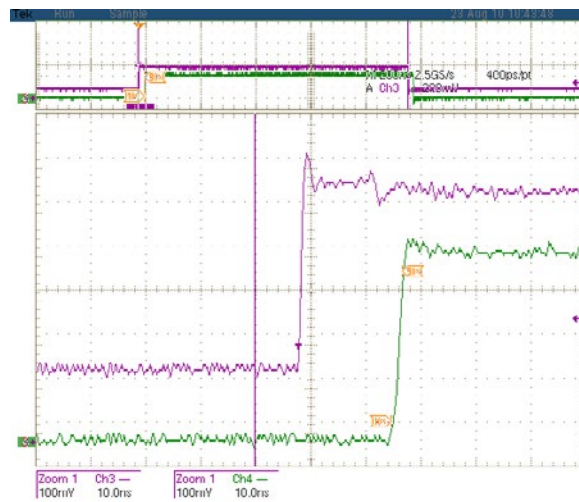

### Power Supply (#3) and Supply Absolute Maximum Ratings

The seed driver requires a stabilized +5V for the  $\mu$ C and TEC and a separated stabilized +5 V for the laser driver itself.

The  $\mu$ C supply must not shut down before the laser driver supply is down.

The laser driver supply can be interrupted at any time for e.g. safety reasons by the customer.

If this kind of safety function is not required, both + 5 V may be connected together.

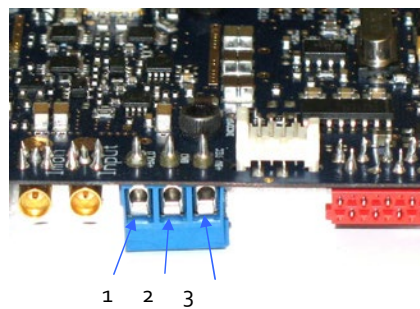

Pin of conn. #3	Allowed range	Best performance	Destroying limit
1 (laser supply)	4.75 V .. 5.5 V	+ 5.5 V	+ 6.5 V
2 (GND)	GND	GND	
3 ( $\mu$ C & TEC)	4.75 V .. 5.25 V	+ 5.0 V	+ 6 V

### Description of the RS232 Connector (#4)

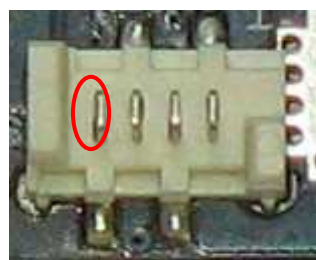

Pin Number	Description	Direction	Comments
1 (marked in red)	+12 V	Output	Only for the use with the PLB21, prevent any overload or short! (max. 100 mA)
2	TXD	I/O	RS232-Standard serial interface
3	RXD	I/O	RS232-Standard serial interface
4 (right)	GND	Output	

The RS232 Interface can be used with a PC and a Terminal-Program or with the PLB-21.

### How to connect the PLB-21 to the RS232 Connector (#4)

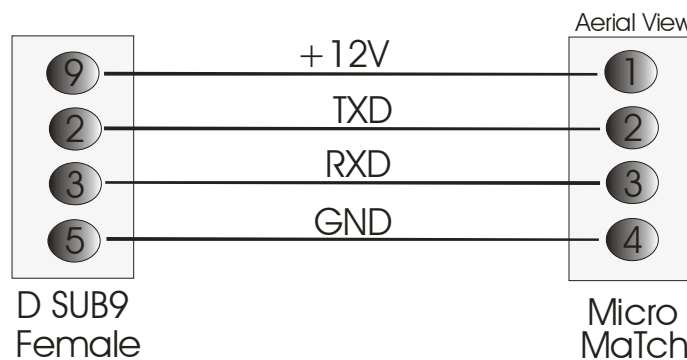

To connect the PLB-21 to the seed driver, a cable according the scheme above is required.

- D SUB9 female on cable: Harting 0966118 7500
- Micro MaTch on cable: Molex 90327-0304



### Description of the I/O Connector (#5)

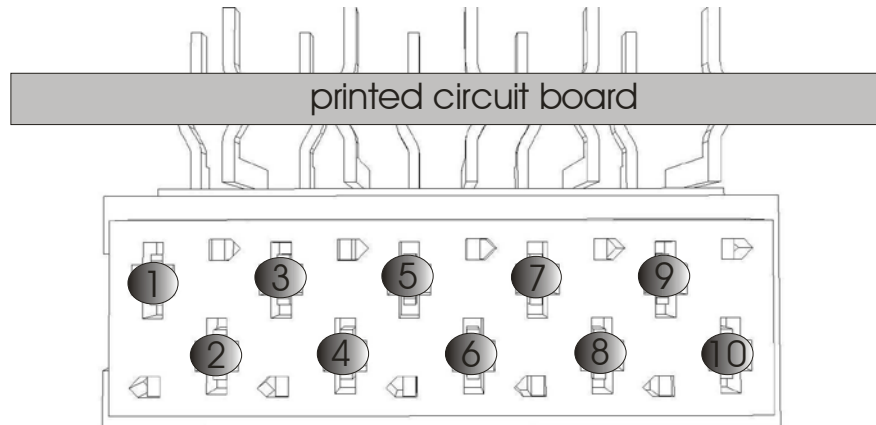

Pin	LDS-VRHSP-02-BF	BFS-VRM-03
1	GND	GND
2	Laser-Fire	Laser-Fire
3	GND	GND
4	NC	TxD RS232
5	GND	GND
6	Over / Under Temperature	Over / Under Temperature
7	GND	GND
8	NC	RxD RS232
9	SCL (I2C)	SCL (I2C)
10	SDA (I2C)	SDA (I2C)

## Linearity

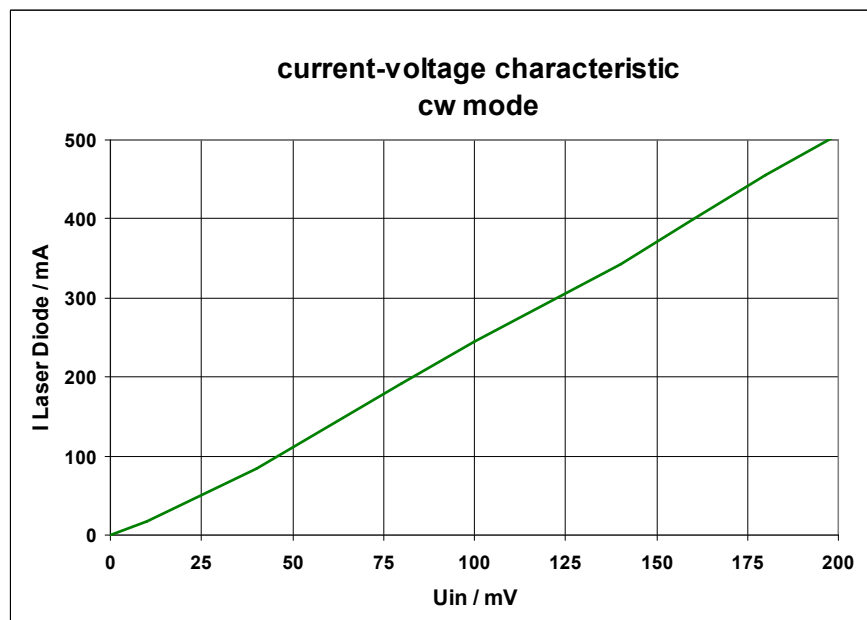
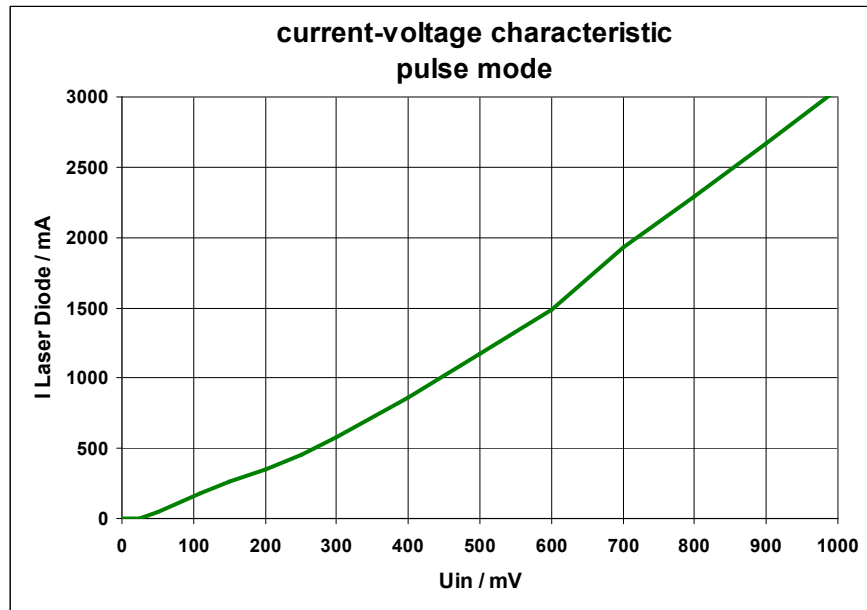

## Cooling

The seed driver is base plate cooled only. Please assemble the entire unit to a heatsink which is capable to take out the heat.

The heatsink is suitable, if the system temperature does not exceed the maximum operating limits. To achieve best performance the base plate temperature should be kept in the range of + 10 °C ... + 35 °C.

The peak heat load is 25 W.

## Test Load

For the first testings a test load may be assembled instead of the laser diode. This test load may be a short circuit or a fast schottky diode like ES<sub>3</sub>C. Please connect the test load only between Anode and Cathode (LD+ and LD-) and prevent shorts to any other part of the circuit.

## TEC Stage

The seed driver has got an internal TEC stage to drive typical TECs inside the butterfly-package.

All parameters can be set digitally via I<sup>2</sup>C, RS<sub>232</sub> or the PLB-21. There is no analogue input or potentiometers for these setpoints on the board.

- TEC set-point adjustment: + 0 °C ... + 70 °C
- TEC temperature accuracy: +/- 0.1 °C

Switching points at > 1.5°C from set point temperature result a Low-Signal on the over / under temperature output.

If the actual temperature reaches the set point temperature the over / under temperature output will be pulled to a high signal.

### ***Laser fire monitoring output (#5-2)***

The seed driver is equipped with a laser firing monitor (Terminal #5, Pin 2). The output is TTL and gets high whenever the current of back facet monitor diode is above the triggering threshold.

- Output: + 5V TTL (active = HIGH)
- Output style: Open collector, internal pullup 220 R, short circuit current max. 25 mA.
- Threshold setpoint is set digitally via I2C, RS232 or PLB-21
- Output remains high if signal remain above threshold
- Short pulses are prolonged to 500 ns (retriggerable monoflop)
- A high-frequency pulse train (pulse distance shorter than 500 ns) will appear as a constant high-signal at the output.

## Mechanical Dimensions

The following dimensions are in millimetres (mm).

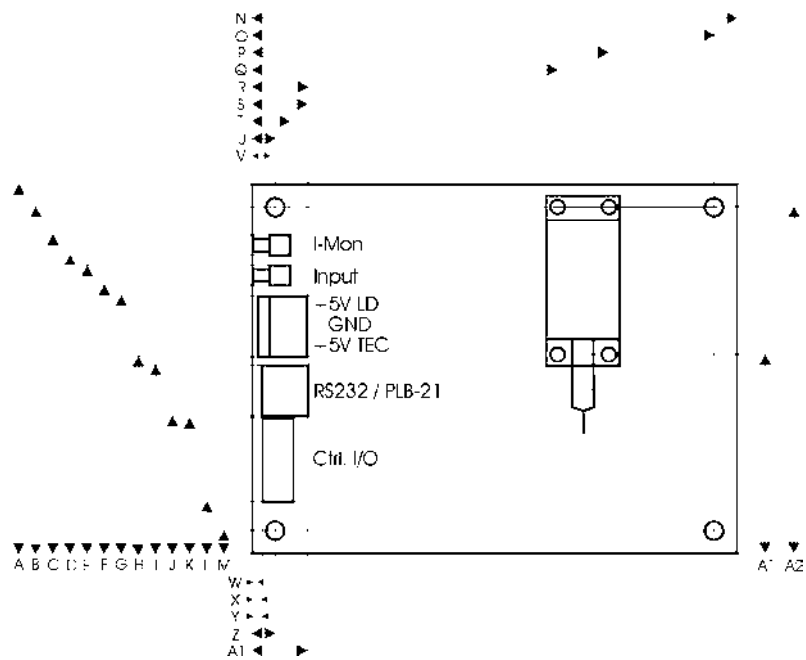

A	65
B	61
C	56
D	52,4
E	50,7
F	47,1
G	45,3
H	37,7
I	33,3
J	24,2
K	23,9
L	9
M	4
N	85

O	81
P	62,55
Q	53,65
R	9,5
S	9,45
T	56
U	4
V	3
W	0,8
X	1,7
Y	1,9
Z	4
A1	35,05
A2	61,05

The following dimensions are in millimetres (mm).

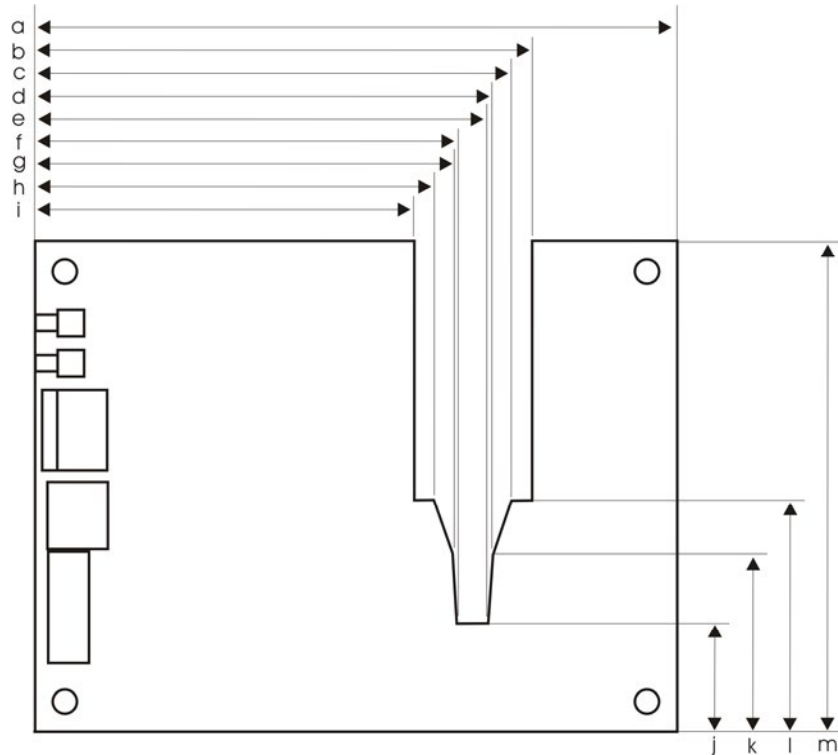

a	85
b	65,5
c	63,1
d	60,7
e	59,8
f	56,3
g	55,6
h	53,1
i	50,7
j	15,1
k	24
l	31,1
m	65

## I<sup>2</sup>C Interface

The driver is equipped with a standard I<sup>2</sup>C slave interface. It supports 7 bit slave addressing and is 3.3/5V compatible. It implements an I<sup>2</sup>C ram with 32bit wide data words. An internal address counter increments automatically as soon as 3 bytes of a register are read/written. All registers are big endian encoded. It is possible to read out or write all registers in a row. Any changes are applied as soon as a complete register is written.

Write commands need some time to complete, thus the I<sup>2</sup>C slave uses the clock stretching technique to notify the master that it is not ready. The I<sup>2</sup>C master must be able to detect clock stretching if more than one register is written at a time.

The following table shows the internal register assignment:

address	name	register size	unit
0	bias min	32 bit	mA
1	bias max	32 bit	mA
2	bias setpoint	32 bit	mA
3	uincomp min	32 bit	--
4	uincomp max	32 bit	--
5	uincomp setpoint	32 bit	--
6	actual +5V LD	32 bit	0.01 V
7	actual +5V TEC	32 bit	0.01 V
8	actual TEC temperature	32 bit	0.1 °C
9	actual TEC current	32 bit	0.1 °C
10	actual NTC temperature	32 bit	0.1 °C
11	TEC Kp min	32 bit	--
12	TEC Kp max	32 bit	--
13	TEC Kp	32 bit	--
14	TEC Ki min	32 bit	--
15	TEC Ki max	32 bit	--
16	TEC Ki	32 bit	--
17	TEC Kd min	32 bit	--
18	TEC Kd max	32 bit	--
19	TEC Kd	32 bit	--
20	TEC min setpoint	32 bit	0.1 °C
21	TEC max setpoint	32 bit	0.1 °C
22	TEC setpoint	32 bit	0.1 °C
23	TEC current limiter max	32 bit	0.01 A
24	TEC current limiter min	32 bit	0.01 A
25	TEC current limiter setpoint	32 bit	0.01 A
26	Vref min	32 bit	0.01 V
27	Vref max	32 bit	0.01 V
28	Vref setpoint	32 bit	0.01 V
29	ERROR register	32 bit	--

30	LSTAT register	32 bit	--
31	Ugate2 min	32 bit	0.01 V
32	Ugate2 max	32 bit	0.01 V
33	Ugate2 setpoint	32 bit	0.01 V



## Controlling the BFS-VRM-03 using a PLB-21

To control the driver with a PLB-21 it must be connected via the enclosed cable. When the PLB-21 is connected the first time you are asked to download a new driver. This must be confirmed with "yes" for working the PLB-21 properly.

### Menu Structure

The following diagram shows the structure of the PLB-21 menu which affects the driver. All entries are described in detail. All other menu entries are described in the PLB-21 manual. For detailed instructions see the PLB-21 manual.

#### Menu root

- Setpoint
  - o Uincomp
  - o Bias
  - o Vref
  - o Ugate2
- TEC Setpoint
  - o TEC stp.
  - o TEC act.
- TEC Control
  - o Kp
  - o Ki
  - o Kd
  - o I<sub>max</sub> (A)
- Measurement
  - o 5V
  - o 5V1
  - o Temp TEC
  - o I TEC
  - o Temp NTC
- Defaults
  - o def. pwr on
  - o load defaults
  - o save defaults
- I<sub>2</sub>C
  - o I<sub>2</sub>C Addr.

## Setpoint



### Uincomp

This Value is part of the calibration procedure performed at PicoLAS. It must not be changed by customer. Changes have an impact on the performance of the driver and may damage the LD and the driver. These changes are not issue of warranty. All changes are monitored and will cause the lost of the warranty.



### Bias

This Value is part of the calibration procedure performed at PicoLAS. It must not be changed by customer. Changes have an impact on the performance of the driver and may damage the LD and the driver. These changes are not issue of warranty. All changes are monitored and will cause the lost of the warranty.

### Vref

This value is the "Threshold level" of the laser firing monitor. If the photocurrent is higher than the level, the monoflop will be triggered and the laser firing output is set high.



### Ugate2

This Value is part of the calibration procedure performed at PicoLAS. It must not be changed by customer. Changes have an impact on the performance of the driver and may damage the LD and the driver. These changes are not issue of warranty. All changes are monitored and will cause the lost of the warranty.

## TEC Setpiont

### TEC stp.

This value defines the temperature setpoint of the TEC controller.

### TEC. act.

This value shows the actual measured temperature of the TEC controller.

## TEC Control

### Kp

This value defines the strength of the proportional part of the TEC controller.

### Ki

This value defines the strength of the integral part of the TEC controller.

### Kd

This value defines the strength of the differential part of the TEC controller.

### Imax (A)

This value defines the maximum current output of the TEC controller.

### Measurement

#### 5V

This value represents the actual measured voltage of the +5V LD supply voltage input.

#### 5V1

This value represents the actual measured voltage of the +5V TEC supply voltage input.

#### Temp TEC

This value represents the actual measured TEC temperature.

#### I TEC

This value represents the actual measured TEC output current.

#### Temp NTC

This value represents the actual measured temperature of the onboard NTC.

### Defaults

#### def. pwron

If enabled the BFS-VRM-03 loads default values every time it is powered on. These values are CRC checked at power-up. If this check fails the values are not loaded and an error message is displayed.

#### Save defaults

When the Jogdial is turned or the ENTER key is pressed all current values are saved.

#### Load defaults

When the Jogdial is turned or the ENTER key is pressed all current values are overwritten by the saved ones. If the output was enabled at this time it becomes disabled.

### I2C

#### I2C Addr.

This value defines the address on which the driver listens on the I2C bus.

## Controlling via USB

### Introduction

In addition to the PLB-21, the driver also has a USB interface to communicate with a computer/laptop. This interface allows communications over a serial text interface as well as using the PicoLAS protocol. While the text interface is designed for communication with a terminal program, the PicoLAS protocol is designed as a system interact protocol.

The switching between the two protocols occurs automatically as soon as the driver receives a certain sequence. The corresponding commands are:

- **PING** for the PicoLAS protocol (binary command, see below)
- **"init"** followed by <Enter> for the text interface

### Description of the USB Interface

The USB connection of the BFS-VRM 03 emulates a virtual COM port under Windows. The necessary drivers can be downloaded free of charge under <http://www.ftdichip.com/Drivers/VCP.htm>, or they are already included in the current Linux kernels. The virtual COM port created by this can be addressed like a regular one. The connection settings are:

Baud rate	115200
Data bits	8
Stop bits	1
Parity	even

## The Serial Text Interface

The following section describes the structure and commands of the text interface.

### Structure

Every command that is sent to the driver must be completed with a CR (Enter). It consists of a command word followed by one or more parameters. If the command was successfully executed a "00" is sent, otherwise a "01". If there is an error pending, the response will be "10", otherwise "11". If the command requires an answer parameter, this parameter is sent before the confirmation is given.

Example:

The user would like to read out the actual temperature setpoint:

User input: gtsoll<Enter>

Output of the driver: 250<CR><LF>  
00<CR><LF>

Example 2:

The user would like to set a new setpoint current:

User input: stsoll 270<Enter>

Output of the driver: 270<CR><LF>  
00<CR><LF>

Input is done in ASCII code and is case sensitive. Every terminal can be used that supports this standard.

### Commands for the BFS-VRM-03

The following table contains a command reference for the BFS-VRM-03.

Command	Parameter	Description
ghwver	-	returns the hardware version number
gswver	-	returns the software version number
gserial	-	returns the serial number
gname	-	returns the device name
ps	-	prints out all settings
loaddef	-	load default values
savedef	-	save all settings as default values
autoload	1 / 0	enables or disables the automatic loading of default settings on power on
gerrtxt	-	returns the error register in text-form
gerr	-	returns the error register as a 32bin number
glistat	-	returns the laser status register
slstat	32bit number	sets the laser status register to the given value
guincompmin	-	returns the minimum possible UinComp voltage
guincompmax	-	returns the maximum possible UinComp voltage
guincomp	-	returns the actual UinComp voltage
suincomp	value	sets the UinComp voltage to the given value
gbiasmin	-	returns the minimal bias current
gbiasmax	-	returns the maximal bias current
gbias	-	returns the actual bias current
sbias	current in [A]	sets the bias current to the given value
gugate2min	-	returns the minimum possible Ugate2 voltage
gugate2max	-	returns the maximum possible Ugate2 voltage
gugate2	-	returns the actual Ugate2 voltage
sugate2	voltage in [V]	sets the Ugate2 voltage to the given value

Command	Parameter	Description
gvrefmin	-	returns the minimal VREF value in [V]
gvrefmax	-	returns the maximal VREF value in [V]
gvref	-	returns the actual VREF value in [V]
svref	voltage in [V]	sets VREF to the given value in [V]
gi2cmin	-	returns the minimal possible I <sup>2</sup> C address
gi2cmax	-	returns the maximal possible I <sup>2</sup> C address
gi2c	-	returns the actual I <sup>2</sup> C address
si2c	value	sets the I <sup>2</sup> C address to the given value
g5v1	-	returns the actual voltage of the +5V TEC input in [V]
g5v	-	returns the actual voltage of the +5V LD input in [V]
gitec	-	returns the actual TEC current in [A]
gttec	-	returns the actual TEC temperature in [°C]
gtntc	-	returns the actual temperature of the onboard NTC in [°C]
gtist	-	returns the actual laser diode temperature in [°C]
gtsollmin	-	returns the minimal TEC temperature setpoint in [°C]
gtsollmax	-	returns the maximal TEC temperature setpoint in [°C]
gtsoll	-	returns the actual TEC temperature setpoint in [°C]
stsoll	-	sets the TEC temperature setpoint to the given value in [°C]
gkpmin	-	returns the minimal strength of the proportional part of the TEC controller
gkpmax	-	returns the maximal strength of the proportional part of the TEC controller
gkp	-	returns the actual strength of the proportional part of the TEC controller
skp	value	sets the strength of the proportional part of the TEC controller to the given value
gkimin	-	returns the minimal strength of the integral part of the TEC controller
gkimax	-	returns the maximal strength of the integral part of the TEC controller
gki	-	returns the actual strength of the integral part of the TEC controller
ski	value	sets the strength of the integral part of the TEC controller to the given value

Command	Parameter	Description
gkadmin	-	returns the minimal strength of the differential part of the TEC controller
gkdmax	-	returns the maximal strength of the differential part of the TEC controller
gkd	-	returns the actual strength of the differential part of the TEC controller
skd	value	sets the strength of the differential part of the TEC controller to the given value
gimaxmin	-	returns the minimum current limiter value in [A]
gimaxmax	-	returns the maximum current limiter value in [A]
gimax	-	returns the actual current limiter value in [A]
simax	current in [A]	sets the TEC current limiter to the given value



### ***If an Error Occurs***

If an error occurs during operation the pulse output is switched off and the return value of a command is no longer "00" or "01" but "10" or "11".

To retrieve the error, use the **gerror** command for the content of the ERROR register or the **gerrtxt** command for a human readable form.

## The PicoLAS Protocol

The following section describes the structure and possible commands of the PicoLAS protocol.

### Structure

Each transmission consists of 12 bytes – called a frame as follows – which must be sent consecutively. Otherwise the system times out and the transmission must start again from the beginning.

A frame has a fixed structure. The first two bytes describe the command, the following eight bytes the parameters, followed by one reserved byte and one checksum byte. The checksum is calculated out of the first 11 bytes which are linked by a bitwise XOR.

Thus a frame has the following structure:

Byte	Meaning
1	Bit 8-15 of the command
2	Bit 0-7 of the command
3	Bit 56-63 of the parameter
4	Bit 48-55 of the parameter
5	Bit 40-47 of the parameter
6	Bit 32-39 of the parameter
7	Bit 24-31 of the parameter
8	Bit 16-23 of the parameter
9	Bit 8-15 of the parameter
10	Bit 0-7 of the parameter
11	Reserved, always 0x00
12	Checksum

A properly received frame must be acknowledged by the recipient with an answer, which is also a frame. If the acknowledgement does not occur the command has not been processed and the sending procedure should be repeated.

If the recipient recognizes the command as valid, but not the parameters, then it will answer with an ILGLPARAM (0xFF12) as command.

In case that the recipient receives an invalid command it will answer with UNCOM (0xFF13).

If a faulty checksum is recognized then the answer is RXERROR (0xFF10). If this error occurs often the connection should be checked.

Using the REPEAT (0xFF11) command the recipient can instruct the sender to send the most recent frame again.

## General Commands

The following list contains an overview of the general commands which are supported by every product from PicoLAS which makes use of this protocol. The explanation of the individual commands is given further below.

Command Name	Sent Frame		Answer Frame	
	Command	Parameter	Command	Parameter
<b>PING</b>	0xFE01	0	0xFF01	0
<b>IDENT</b>	0xFE02	0	0xFF02	ID
<b>GETHARDVER</b>	0xFE06	0	0xFF06	Version
<b>GETSOFTVER</b>	0xFE07	0	0xFF07	Version
<b>GETSERIAL</b>	0xFE08	0 ... 255	0xFF08	Refer to description
<b>GETIDSTRING</b>	0xFE09	0 ... 255	0xFF09	Refer to description

### PING

This command is used to determine the presence of a connected device and to initialize the interface. It has no effect on the condition of the recipient. The command parameter is always zero, the answer parameter too.

### IDENT

It is used to determine the device ID of an attached recipient. Has no effect on the condition of the recipient. The parameter is always 0. The answer contains the ID.

### GETHARDVER

This command instructs the recipient to send back the version number of the hardware being used. The parameter is always zero. The answer contains the hardware version of the recipient. The format of the answer is: 0x000000<major><minor><revision>. In other words, one byte for each of the three elements of the version number.

As example, version 1.2.3 has the parameter 0x000000010203.

### GETSOFTVER

Instructs the recipient to send back the version number of the software being used. The parameter is always 0.

The answer contains the software version of the recipient. The format of the answer is: 0x000000<major><minor><revision>. In other words, one byte for each of the three elements of the version number.

As example, version 2.3.4 has the parameter 0x000000020304.

### GETSERIAL

Instructs the recipient to send back its serial number. If 0 is sent as parameter, the answer contains the number of (ASCII) digits of the serial number; otherwise the respective position of the serial number is sent in ASCII format.

### GETIDSTRING

Instructs the recipient to send back the name of the device. If 0 is sent as parameter, the answer contains the number of digits of the string, otherwise the respective position of the serial number is sent in ASCII format.

In addition to these commands there are some answers, which can be given to every command:

Answer	Answer Frame	
	Command	Parameter
<b>RXERROR</b>	0xFF10	0
<b>REPEAT</b>	0xFF11	0
<b>ILGLPARAM</b>	0xFF12	0
<b>UNCOM</b>	0xFF13	0

**RXERROR**

If a frame is repeated four times and still broken this answer will be send.

**REPEAT**

The last frame was received in a broken state. The transmission must be repeated. This can be up to four times before a RXERROR will be send.

**ILGLPARAM**

The parameter of the last frame had an incorrect value.

**UNCOM**

The command of the last frame is unknown by the device.

### Commands for the driver

The following table contains a list of the commands which the driver supports in addition to the generally applicable commands. An explanation of each individual command follows afterwards.

Command	Sent Frame		Received Frame	
	Command	Parameter	Command	Parameter
GETBIASMIN	0x0010	-	0x0110	minimum current in [mA]
GETBIASMAX	0x0011	-	0x0110	maximum current in [mA]
GETBIAS	0x0012	-	0x0110	actual current in [mA]
SETBIAS	0x0013	bias current in [mA]	0x0110	actual current in [mA]
GETUINCOMPMIN	0x0020	-	0x0120	minimum possible value
GETUINCOMPMAX	0x0021	-	0x0120	maximum possible value
GETUINCOMP	0x0022	-	0x0120	actual value
SETUINCOMP	0x0023	value	0x0120	actual value
GETMESS5V	0x0030	-	0x0130	+5V LD voltage in 0.01 [V]
GETMESS5V1	0x0031	-	0x0130	+5V TEC voltage in 0.01 [V]
GETMESSTTEC	0x0032	-	0x0130	TEC temperature in 0.1 [°C]
GETMESSITEC	0x0033	-	0x0130	TEC current in 0.01 [A]
GETMESSTNTC	0x0034	-	0x0130	NTC temperature in 0.1 [°C]
GETTECKPMIN	0x0040	-	0x0140	minimum TEC Kp value
GETTECKPMAX	0x0041	-	0x0140	maximum TEC Kp value
GETTECKP	0x0042	-	0x0140	actual TEC Kp value
SETTECKP	0x0043	Kp value	0x0140	actual TEC Kp value
GETTECKIMIN	0x0044	-	0x0140	minimum TEC Ki value
GETTECKIMAX	0x0045	-	0x0140	maximum TEC Ki value
GETTECKI	0x0046	-	0x0140	actual TEC Ki value
SETTECKI	0x0047	Ki value	0x0140	actual TEC Ki value
GETTECKDMIN	0x0048	-	0x0140	minimum TEC Kd value
GETTECKDMAX	0x0049	-	0x0140	maximum TEC Kd value
GETTECKD	0x004A	-	0x0140	actual TEC Kd value
SETTECKD	0x004B	Kd value	0x0140	actual TEC Kd value
GETTECSOLLMIN	0x004C	-	0x0140	minimum setpoint in 0.1 [°C]
GETTECSOLLMAX	0x004D	-	0x0140	maximum setpoint in 0.1 [°C]
GETTECSOLL	0x004E	-	0x0140	actual setpoint in 0.1 [°C]
SETTECSOLL	0x004F	setpoint in 0.1 [°C]	0x0140	actual setpoint in 0.1 [°C]

Command	Sent Frame		Received Frame	
	Command	Parameter	Command	Parameter
GETTECACT	0x0050	-	0x0140	actual TEC temp. in 0.1 [°C]
GETTECIMAXMIN	0x0051	-	0x0140	minimum TEC current limiter value in 0.01 [A]
GETTECIMAXMAX	0x0052	-	0x0140	maximum TEC current limiter value in 0.01 [A]
GETTECIMAX	0x0053	-	0x0140	actual TEC current limiter value in 0.01 [A]
SETTECIMAX	0x0054	current in 0.01 [A]	0x0140	actual TEC current limiter value in 0.01 [A]
GETVREFMIN	0x0060	-	0x0160	minimum voltage in 0.01 [V]
GETVREFMAX	0x0061	-	0x0160	maximum voltage in 0.01 [V]
GETVREF	0x0062	-	0x0160	actual voltage in 0.01 [V]
SETVREF	0x0063	voltage in 0.01 [V]	0x0160	actual voltage in 0.01 [V]
GETERROR	0x0070	-	0x0170	ERROR register
GETLSTAT	0x0071	-	0x0170	LSTAT register
SETLSTAT	0x0072	32 bit value	0x0170	LSTAT register
GETREGS	0x0073	-	0x0170	see below
CLEARERROR	0x0074	-	0x0170	-
SAVEDEFAULT	0x0080	-	0x0180	-
LOADDEFAULT	0x0081	-	0x0180	-
GETUGATE2MIN	0x0090	-	0x0190	minimum voltage in 0.01 [V]
GETUGATE2MAX	0x0091	-	0x0190	maximum voltage in 0.01 [V]
GETUGATE2	0x0092	-	0x0190	actual voltage in 0.01 [V]
SETUGATE2	0x0093	voltage in 0.01 [V]	0x0190	actual voltage in 0.01 [V]
GETI2CMIN	0x00A0	-	0x01A0	minimum I <sup>2</sup> C address
GETI2CMAX	0x00A1	-	0x01A0	maximum I <sup>2</sup> C address
GETI2C	0x00A2	-	0x01A0	actual I <sup>2</sup> C address
SETI2C	0x00A3	I <sup>2</sup> C address	0x01A0	actual I <sup>2</sup> C address

## Description of the Individual Commands

### GETBIASMIN

Returns the minimum possible bias current, measured in [mA].

### GETBIASMAX

Returns the maximum possible bias current, measured in [mA].

### GETBIAS

Returns the actual bias current, measured in [mA].

### SETBIAS

Sets the bias current to the given value. It must be within the borders defined by GETBIASMIN and GETBIASMAX. The value is measured in [mA].

### GETUINCOMPMIN

Returns the minimum possible UinComp voltage.

### GETUINCOMPMAX

Returns the maximum possible UinComp voltage.

### GETUINCOMP

Returns the actual UinComp voltage.

### SETUINCOMP

Sets the UinComp to the given value. It must be within the borders defined by GETUINCOMPMIN and GETUINCOMPMAX.

### GETMESS5V

Returns the actual measured voltage of the +5V LD input. The value is measured in 0.01 [V].

### GETMESS5V1

Returns the actual measured voltage of the +5V TEC input. The value is measured in 0.01 [V].

### GETMESSTTEC

Returns the actual measured TEC temperature. The value is measured in 0.1 [°C].

### GETMESSITEC

Returns the actual measured TEC current. The value is measured in 0.01 [A].

### GETMESSTNTC

Returns the actual measured NTC temperature. The value is measured in 0.1 [°C].

### GETKPMIN

Returns the minimum possible strength of the proportional part of the TEC controller.

**GETKPMAX**

Returns the maximum possible strength of the proportional part of the TEC controller.

**GETKP**

Returns the actual strength of the proportional part of the TEC controller.

**SETKP**

Sets the strength of the proportional part of the TEC controller to the given value. It must be within the borders defined by GETKPMIN and GETKPMAX.

**GETKIMIN**

Returns the minimum possible strength of the integral part of the TEC controller.

**GETKIMAX**

Returns the maximum possible strength of the integral part of the TEC controller.

**GETKI**

Returns the actual strength of the integral part of the TEC controller.

**SETKI**

Sets the strength of the integral part of the TEC controller to the given value. It must be within the borders defined by GETKIMIN and GETKIMAX.

**GETKDMIN**

Returns the minimum possible strength of the differential part of the TEC controller.

**GETKDMAX**

Returns the maximum possible strength of the differential part of the TEC controller.

**GETKD**

Returns the actual strength of the differential part of the TEC controller.

**SETKD**

Sets the strength of the differential part of the TEC controller to the given value. It must be within the borders defined by GETKDMIN and GETKDMAX.

**GETTECSOLLMIN**

Returns the minimum possible temperature setpoint of the TEC controller. The value is measured in 0.1 [°C].

**GETTECSOLLMAX**

Returns the maximum possible temperature setpoint of the TEC controller. The value is measured in 0.1 [°C].

**GETTECSOLL**

Returns the actual temperature setpoint of the TEC controller. The value is measured in 0.1 [°C].



**SETTECSOLL**

Sets the temperature setpoint of the TEC controller to the given value. It must be within the borders defined by GETTECSOLLMIN and GETTECSOLLMAX. The value is measured in 0.1 [°C].

**GETTECACT**

Returns the actual measured temperature of the TEC controller. The value is measured in 0.1 [°C].

**GETTECIMAXMIN**

Returns the minimum possible value for the TEC current limiter. The value is measured in 0.01 [A].

**GETTECIMAXMAX**

Returns the maximum possible value for the TEC current limiter. The value is measured in 0.01 [A].

**GETTECIMAX**

Returns the actual value for the TEC current limiter. The value is measured in 0.01 [A].

**SETTECIMAX**

Sets the TEC current limiter to the given value. It must be within the borders defined by GETTECIMAXMIN and GETTECIMAXMAX. The value is measured in 0.01 [A].

**GETVREFMIN**

Returns the minimum possible reference voltage, measured in 0.01 [V].

**GETVREFMAX**

Returns the maximum possible reference voltage, measured in 0.01 [V].

**GETVREF**

Returns the actual reference voltage, measured in 0.01 [V].

**SETVREF**

Sets the reference voltage to the given value. It must be within the borders defined by GETVREFMIN and GETVREFMAX. The value is measured in 0.01[V].

**GETERROR**

Returns the content of the error register (32bit). For a detailed description of the single bits see chapter "description of the ERROR register".

**GETLSTAT**

Returns the content of the laser status register (32bit). For a detailed description of the single bits see chapter "description of the LSTAT register".

**SETLSTAT**

Sets the laser status register to the given value. The return value contains the acquired register content. For a detailed description of the single bits see chapter "description of the LSTAT register".

**GETREGS**

Returns the content of the laser status register and the error register in a single 64bit word. The upper 32 bit represents the ERROR, the lower 32bit the LSTAT register.

**CLEARERROR**

This command clears the ERROR register. It is currently not used.

**LOADDEFAULTS**

This command replaces all internal parameters with their default values. If the output is enabled during the execution of this command, the L\_ON bit of the LSTAT register will be cleared and the output disabled. This command will fail if the CRC\_DEFAULT\_FAIL bit in the ERROR register is set, indicating an error within the data.

If the DEF\_PWRON bit in the LSTAT register is set, the device automatically loads these values during power-up.

**SAVEDEFAULTS**

This command saves all internal parameters into an EEPROM for later usage. Use command LOADDEFAULTS to restore them.

**GETUGATE2MIN**

Returns the minimum possible Ugate2 voltage, measured in 0.01 [V].

**GETUGATE2MAX**

Returns the maximum possible Ugate2 voltage, measured in 0.01 [V].

**GETUGATE2**

Returns the actual Ugate2 voltage, measured in 0.01 [V].

**SETUGATE2**

Sets the to the given value. It must be within the borders defined by GETUGATE2MIN and GETUGATE2MAX. The value is measured in 0.01[V].

**GETI2CMIN**

Returns the minimum possible I<sup>2</sup>C address.

**GETI2CMAX**

Returns the maximum possible I<sup>2</sup>C address.

**GETI2C**

Returns the actual possible I<sup>2</sup>C address.

**SETI2C**

Sets the I<sup>2</sup>C to the given value. It must be within the borders defined by GETI2CMIN and GETI2CMAX.

### Description of the LSTAT Register

The following list contains a description of the individual LSTAT bits. These can be read with the GETLSTAT and written with SETLSTAT command.

Bit	Name	Read/Write	Meaning
0	PULSER_OK	ro	When "1" there is no error pending
1	DEF_PWRON	r/w	When "1", the driver load its default values on startup.
2	SAVE_DEF	w	When set to "1" the driver load its default values. Always read "0".
3	LOAD_DEF	w	When set to "1" the driver save the current settings as new default values. Always read "0".
4-31	Reserved	ro	Reserved

### Description of the ERROR Register

The following list contains a description of the individual bits of the ERROR register. It can be read with the GETERROR command.

Bit	Name	Read/Write	Meaning
0	CFG_CHKSUM_FAIL	ro	A CRC error was detected in the internal configuration values. Please contact your distributor.
1	PLB_CHKSUM_FAIL	ro	A CRC error was detected in the PLB driver. The driver cannot be used. This does not affect the device but the PLB.
2	DEF_CHKSUM_FAIL	ro	A CRC error was detected in the default values. A re-save of the values should correct this.
3	VCC_LD_FAIL	ro	The measured voltage on the +5V LD input is not within valid range.
4	VCC_TEC_FAIL	ro	The measured voltage on the +5V TEC input is not within valid range.
5-31	reserved	ro	