

2 YEAR
WARRANTY

MADE IN
USA

OMEGA
CARESM
Extended Warranty
Program

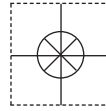

User's Guide



230 VAC Model Only

Shop online at

omega.com[®]

Ω OMEGA[®]

omega.com

e-mail: info@omega.com

For latest product manuals:

omegamanual.info

ISO 9001
CERTIFIED
CORPORATE QUALITY

STAMFORD, CT

ISO 9002
CERTIFIED
CORPORATE QUALITY

MANCHESTER, UK



BB704 Blackbody Calibrator



OMEGAnet® Online Service
omega.com

Internet e-mail
info@omega.com

Servicing North America:

U.S.A.:
ISO 9001 Certified

One Omega Drive, P.O. Box 4047
Stamford, CT 06907-0047
TEL: (203) 359-1660 FAX: (203) 359-7700
e-mail: info@omega.com

Canada:

976 Bergar
Laval (Quebec) H7L 5A1, Canada
TEL: (514) 856-6928 FAX: (514) 856-6886
e-mail: info@omega.ca

For immediate technical or application assistance:

U.S.A. and Canada: Sales Service: 1-800-826-6342 / 1-800-TC-OMEGA®
Customer Service: 1-800-622-2378 / 1-800-622-BEST®
Engineering Service: 1-800-872-9436 / 1-800-USA-WHEN®

Mexico: En Español: (001) 203-359-7803 e-mail: espanol@omega.com
FAX: (001) 203-359-7807 info@omega.com.mx

Servicing Europe:

Benelux:

Postbus 8034, 1180 LA Amstelveen, The Netherlands
TEL: +31 (0)20 3472121 FAX: +31 (0)20 6434643
Toll Free in Benelux: 0800 0993344
e-mail: sales@omegaeng.nl

Czech Republic:

Frystatska 184, 733 01 Karviná, Czech Republic
TEL: +420 (0)59 6311899 FAX: +420 (0)59 6311114
Toll Free: 0800-1-66342 e-mail: info@omegashop.cz

France:

11, rue Jacques Cartier, 78280 Guyancourt, France
TEL: +33 (0)1 61 37 2900 FAX: +33 (0)1 30 57 5427
Toll Free in France: 0800 466 342
e-mail: sales@omega.fr

Germany/Austria:

Daimlerstrasse 26, D-75392 Deckenpfronn, Germany
TEL: +49 (0)7056 9398-0 FAX: +49 (0)7056 9398-29
Toll Free in Germany: 0800 639 7678
e-mail: info@omega.de

United Kingdom:

ISO 9002 Certified

One Omega Drive, River Bend Technology Centre
Northbank, Irlam, Manchester
M44 5BD United Kingdom
TEL: +44 (0)161 777 6611 FAX: +44 (0)161 777 6622
Toll Free in United Kingdom: 0800-488-488
e-mail: sales@omega.co.uk

It is the policy of OMEGA Engineering, Inc. to comply with all worldwide safety and EMC/EMI regulations that apply. OMEGA is constantly pursuing certification of its products to the European New Approach Directives. OMEGA will add the CE mark to every appropriate device upon certification.

The information contained in this document is believed to be correct, but OMEGA accepts no liability for any errors it contains, and reserves the right to alter specifications without notice.

WARNING: These products are not designed for use in, and should not be used for, human applications.

Table of Contents

Section	Page
Section 1 Introduction	1-1
1.1 Precautions	1-1
1.2 Safety Warnings and IEC Symbols	1-1
1.3 Statement on CE Marking	1-2
1.4 General Description	1-2
Section 2 Installation	2-1
2.1 Unpacking and Inspection	2-1
2.2 Mounting	2-1
2.3 Ambient Temperature	2-1
2.4 Power Connection	2-1
Section 3 Operation	3-1
3.1 Front Panel Controls and Indicators	3-1
3.2 Back Panel Connections	3-2
3.3 Changing the Temperature Setpoint	3-3
3.4 Changing the Controller Parameter Settings	3-3
3.5 Heat-Up/Cool-Down Cycle Times	3-5
3.6 Thermal Reset Switch	3-5
Section 4 Serial Communications (RS-232)	4-1
Section 5 Maintenance	5-1
5.1 Calibration	5-1
5.2 Cleaning	5-1
5.2.1 Main Body	5-1
5.2.2 Target Plate	5-1
5.2.3 Fan	5-1
5.3 Fuse Replacement	5-1
Section 6 Reference Probe	6-1
Section 7 Specifications	7-1
Section 8 Troubleshooting Guide	8-1
Section 9 Glossary of Terms Used in This Manual	9-1
Section 10 The OMEGA® Family of Blackbody Calibrators	10-1

Table of Figures

Figure	Page
1. IEC Symbols	1-2
2. Front Panel	3-1
3. Back Panel	3-2
4. Menu Hierarchy Showing Factory Default Settings	3-4
5. Programming Procedure	3-4
6. Heat-Up/Cool-Down Cycle Time Table	3-5
7. Connecting the BB704 to a Computer's Serial Port	4-1
8. Internal Reference Probe Connections	6-1

Section 1 - Introduction

Your BB704 Series Blackbody Calibration Source has been designed for ease of use and reliability whenever you have the need to test or calibrate non-contact infrared temperature instruments. It is important that you read this manual completely and follow all safety precautions before operating this instrument.

1.1 Precautions

- Follow all safety precautions and operating instructions outlined in this manual.
- Never leave your calibrator unattended when in use.
- Keep out of reach of children.
- Never touch the target plate when hot.
- Never place any object within 3 inches of the target plate when hot.
- Do not operate in flammable or explosive environments.
- Never operate with a power cord other than the one provided with your unit.
- Remove and/or disconnect main power cord before attempting any maintenance or fuse replacement.
- Do not connect and/or operate this unit to a non-grounded, non-polarized outlet or power source.
- Do not connect the serial port or reference probe port to equipment with exposed, hazardous, live voltages.
- Protect from moisture and rain.
- The operator of this instrument is advised that if the equipment is used in a manner not specified in this manual, the protection provided by the equipment may be impaired.



NOTE:

There are no user serviceable parts inside your unit. Attempting to repair or service your unit may void your warranty.

1.2 Safety Warnings and IEC Symbols

This device is marked with international safety and hazard symbols in accordance with IEC 1010. It is important to read and follow all precautions and instructions in this manual before operating or commissioning this device as it contains important information relating to safety and EMC. Failure to follow all safety precautions may result in injury and/or damage to your calibrator. Use of this device in a manner not specified by the manufacturer may impair protection provided within the unit.





IEC symbols	Description
	Caution, risk of electric shock
	Caution, refer to accompanying documents
	Caution, hot surface
	230 VAC~ @ 50Hz (European Models) 115 VAC~ @ 60Hz (Domestic Models)

Figure 1. IEC Symbols

1.3 Statement on Marking

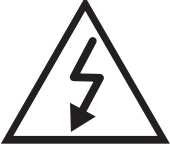
It is the policy of OMEGA® to comply with all world-wide safety and EMI/EMC regulations that apply. OMEGA is constantly pursuing certification of its products to the European New Approach Directives. OMEGA will add the CE mark to every appropriate device upon certification.

1.4 General Description

The Model BB704 is a portable, rugged, bench-top, hot/cold blackbody calibration source with a built-in precision PID digital controller. The calibrator is used to test and calibrate infrared pyrometers. The large 4 inch diameter target plate has an emissivity of 0.95 and can be set to any temperature between 100 to 398°C (212 to 750°F).

Section 2 - Installation

2.1 Unpacking and Inspection

Remove the packing list and verify that you have received all your equipment. If you have any questions about the shipment, please call our Customer Service Department at:

1-800-622-2378 or 203-359-1660.

We can also be reached on the Internet at:

omega.com

e-mail: info@omega.com

When you receive the shipment, inspect the container and equipment for any signs of damage. Note any evidence of rough handling in transit. Immediately report any damage to the shipping agent.

NOTE:

The carrier will not honor any damage claims unless all shipping material is saved for inspection. After examining and removing contents, save packing material and carton in the event reshipment is necessary.

The following items are supplied in the box:

- BB704 Blackbody Calibration Source
- User's Manual
- Calibration Certificate
- Power Cord
- Reference Port Cord Plug Connector

2.2 Mounting

Mount the unit on a bench, table-top, or shelf in a horizontal position and operate at least 10 inches from any air obstructions to the fan, front panel, rear panel, bottom, and top of the unit, in an ambient environment between the specified 0 to 50°C (32 to 122°F).

2.3 Ambient Temperature

The target plate of the BB704 can achieve any temperature within the specified temperature range when being operated in normal ambient temperature environments. The maximum specified target plate temperature of 398°C (750°F) can be achieved over the entire specified ambient temperature range.

2.4 Power Connection

Standard (115 VAC~, 50/60 Hz models)

The BB704 comes with a standard North American 3-prong AC power cord. Do not use any other power cord other than the one provided. This cord provides the proper grounding and has been safety tested by the proper safety agencies.

International (230 VAC~, 50/60 Hz models)

On 230 VAC~, 50/60Hz models, a European style power cord with the proper color code and approvals is provided with stripped wire ends for connection to the proper connector used in your country or local area. This connector is not provided.



- Line voltage variations are not to exceed $\pm 10\%$ of the rated input voltage.
 - Electrical connections and wiring should be performed only by suitably trained personnel.
 - To shut down the unit in an emergency, the power cord can be disconnected from the AC outlet or rear of the unit.
-

Section 3 - Operation

3.1 Front Panel Controls and Indicators

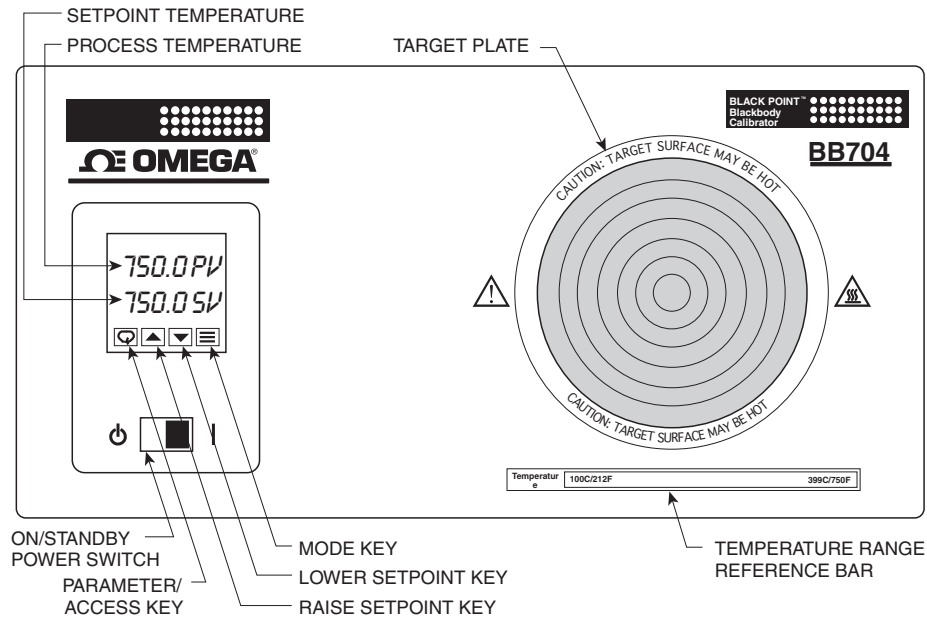

Figure 2. Front Panel

Process Temperature:

This field displays the current temperature of the target plate.

Setpoint Temperature:

This field displays the desired target plate temperature. Once the target plate reaches this desired temperature, both displays will read the same value.

Target Plate:

The 4" target plate is a near ideal blackbody source. The emissivity of the plate is 0.95. When calibrating an IR pyrometer, hold the pyrometer perpendicular to the target plate for optimal performance. The proper distance between the IR pyrometer and the target plate depends on the field of view of the pyrometer. If the pyrometer is too far away, it will scan unwanted surfaces outside of the perimeter of the target plate. Holding the pyrometer too close could introduce undesirable heat to the IR detector of the pyrometer.

CAUTION:

- The BB704's target plate can be set to very high temperatures. Exercise extreme caution when operating the unit. Keep hands and fingers away from the target plate area. Keep flammable products such as paper, plastics, and clothing far from the BB704.
- The BB704 is a Class II instrument. It is intended to be operated in a laboratory environment only. Never operate the unit outdoors or around children.
- Nothing should come in contact with the target plate, even when the unit is off.
- Never unplug the unit while it is on or during "cool down."

NOTE:

PID Control:

Proportional, integral, derivative control (PID) is a temperature control algorithm used in high-end temperature controllers. The controller causes the process to attain the desired temperature by turning the process on or off. The process may be a heater or refrigerator. As the process temperature approaches the setpoint temperature, the hot or cold process will be pulsed to reduce the corrective measures and minimize overshooting. The controller provides a visual representation of the process status through LED indicators. An indicator may light continuously, blink, or shut off entirely to indicate that the process is on, being pulsed, or off, respectively.

**Parameter/Access Key:**

Press to scroll through menu parameters.

**Raise Key:**

Press to increase the selected parameter or scroll upward in the list of possible settings.

**Lower Key:**

Press to decrease the selected parameter or scroll downward in the list of possible settings.

**Mode Key:**

Press to save settings and exit a menu level.

3.2 Back Panel Connections

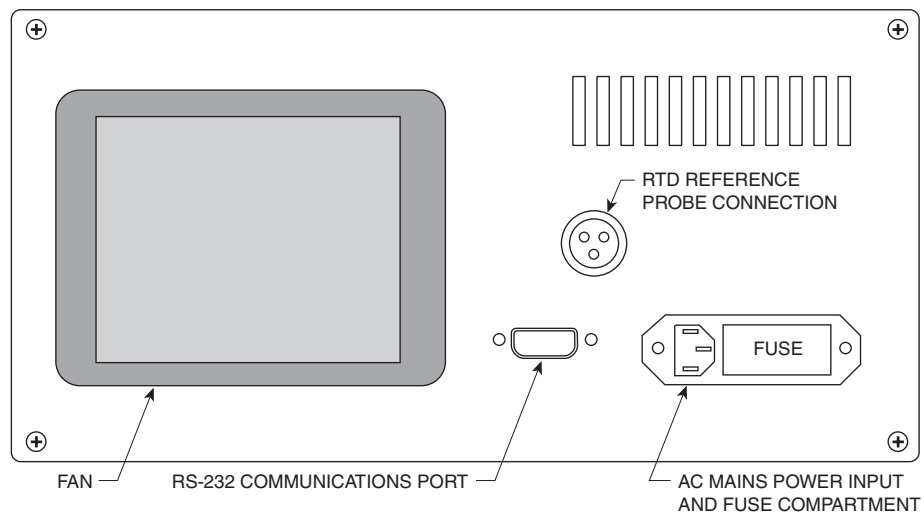

Figure 3. Back Panel

AC Power Mains Input and Fuse Compartment:

The customer connects the power cord to the AC Power Input. As a safety precaution, the power cord cannot be connected if the fuse compartment is open. Refer to Section 5.3 for information on fuse replacement.

Reference Probe Connection:



The reference probe enables the user to monitor the target plate temperature with an external instrument. The wires are connected to a Class A, 0.00385 RTD Sensor.

Refer to Section 6 for pinout details.

RS-232 Communications Port:

The female DB-9 port allows the customer to make a 3-wire RS-232 interface with the BB704. A detailed description of this port is in Section 4.

3.3 Changing the Temperature Setpoint

The layout of the front panel is shown in Figure 2. The BB704 incorporates a PID digital setpoint controller. The upper display indicates the blackbody target plate temperature known as (PV) Process Variable, while the lower display indicates the programmed setpoint known as (SV) Setpoint Variable. Changes to the setpoint, units of measure and communication settings are made via the  and  keys. Holding a key in continuously will cause the setpoint temperature to advance more quickly to a desired value. Three scanning speeds are provided: slow, medium, and fast. The minimum and maximum setpoints are locked.

3.4 Changing the Controller Parameter Settings

The BB704 operates at optimum performance when left with its factory parameter settings. The only internal parameters that the operator should need to change are the engineering units (°F or °C) or the serial communications parameters. See next page for menu hierarchy with factory default settings (Fig. 4) and programming procedure (Fig. 5).







Menu 00	Menu 01	Menu 02	Menu 03	Menu 04	Menu 05
Key Lock	SETPOINT	Ac.Cd = 02	Ac.Cd = 03	Ac.Cd = 04	Ac.Cd = 05
	Ac.Cd				
		Gn.o1 64	ALr1 775	id.no 01	SnSr P
		Gr.o2	ALr2 775	BAUd 12.o.7	Sn.00
		rAtE 29	Cy.t1 05	CAL.L	dEC.P
		rSEt 146	Cy.t2	CAL.H	FILt
		H.Hys	SP.tt OFF		OUt.1 Ht.P
		HyS.1	L.SP.L 212		OUt.2 Alr
		C.HyS	L.SCL		CoL.t nor
		HyS.2	U.SP.L 750		A1.HL HI
		C.SPr	H.SCL		A1.Pd Pr
		SPr.2			A1.OP LAt
		dPnG nl			A2.HL HI
					A2.Pd Pr
					A2.OP LAt
					Unit F

Figure 4. Menu Hierarchy Showing Factory Default Settings

NOTE:

Only the boldface parameters are active for the default mode of operation.

Changing the Controller's Parameter Settings:

1. Press the  key to enter the programming mode. The lower display will alternately display the menu level and "Ac.Cd."
2. Use the  and  keys to change to the desired menu level.
3. Once you have chosen the desired menu use the  key to scroll through the parameters. To change the setting of a given parameter, use the  and  keys.
4. To save settings press the  key. The controller now exits the programming menu and returns to the normal operating mode.
5. To change settings on other menu levels, you must re-enter the programming menu (from step #1).

Putting the Controller In or Out of Standby Mode:



1. To enter the Standby mode hold the  key for 4 seconds until the window flashes "StbY."
2. To exit the Standby mode hold the  key for 4 seconds until the window flashes "tUne." Then press the  key for 4 seconds again until "tUne" stops flashing.

Figure 5. Programming Procedure

NOTE:

In the event that the unit has been operated outside of operating range, the controller alarm will disable the heater and the target plate temperature will not rise. Let the unit cool down completely. Turn the power off and then back on. If the problem is not corrected, contact the factory.

3.5 Heat-Up/Cool-Down Cycle Times

Approximate cycle times for heat up and cool down are given in the table above. To find a given transition time from an initial temperature to a second target temperature, follow this procedure: Look for an initial temperature in the left column. Next, look for the target temperature along the top row. The intersection of the row and column provides the approximate transition time.

TO:	121°C	260°C	398°C	
FROM:				
121°C	X	15 MIN.	25 MIN.	250°F
260°C	25 MIN.	X	18 MIN.	500°F
398°C	32 MIN.	10 MIN.	X	750°F
	250°F	500°F	750°F	TO: FROM:

Figure 6. Heat-Up/Cool-Down Cycle Time Table

3.6 Thermal Reset Switch

In the event that the target plate temperature and/or ambient temperature exceeds the acceptable limit, the thermal reset switch will pop open. The controller will appear to be demanding a temperature increase but the target plate temperature will not rise. Let the unit cool down completely. Press the switch located on the right side of the unit near the handle hinge until a click is heard. If this has no effect, refer to the troubleshooting section.

If the reset switch keeps resetting, call Omega’s Customer Service Department at (203) 359-1660.

NOTES:

Section 4 - Serial Communications (RS-232)

This method allows bi-directional data transfer via a three-conductor cable consisting of signal ground, receive input, and transmit output. **It is recommended that less than 50 feet of shielded cable be used between the computer and this instrument.** This will assure performance of the BB704 to EN61326 standards, under the EMC requirements of the CE mark. Note that multiple instruments cannot be tied to the same port in this configuration. The RS-232 port is optically isolated to eliminate ground loop problems.

Below is a pinout diagram for the serial port of the BB704 as well as the pinout for a 9-pin PC serial port. Use a straight DB9 (female) to DB9 (male) connector cable to connect your computer to the BB704. The cable should be attached only when the computer and BB704 are off.

Only parameters in the parameter list should be modified or queried via the serial port. Other parameters should be viewed or queried from the controller directly. It is highly recommended that baud rate for the controller be modified on the controller directly. Note that both the BB704 and the computer must be communicating with the same serial communications parameters to establish a working communication link.

The serial communications feature can be tested using a terminal emulation package. Note that this controller does not time-out waiting for the next character to be transmitted. Be sure not to use the XON/XOFF or hardware handshaking. Lastly, it should be noted that following a complete transmission to the BB704, a response is sent back. If the message was valid, the changed or queried parameter is echoed back (following the same format). If the message was not according to acceptable format or was attempting to force a parameter out of range, an "ERROR" message is echoed.

Figure 7. Connecting the BB704 to a Computer's Serial Port

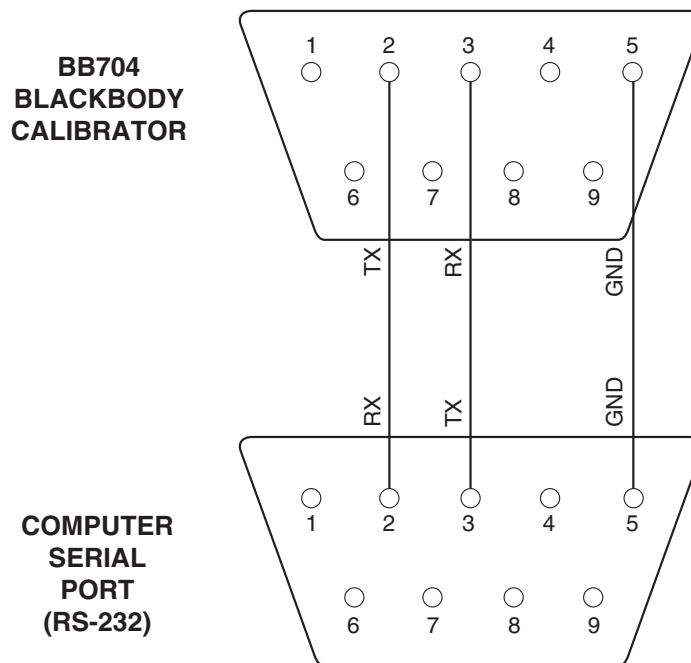

Parameter List (only relevant parameters shown):

<u>PAR#:</u>	<u>Parameter:</u>	<u>Range/Units:</u>
00	Process Temp.	Input determined
01	Setpoint	Input determined
19	Baud Selection	bAUd

Baud Selections:

<u>Code:</u>	<u>Baud:</u>	<u>Parity:</u>	<u>Data Bits:</u>	<u>Stop Bits:</u>
3.o.7	300	odd	7	2
6.o.7	600	odd	7	2
12.o.7	1200	odd	7	2
				(factory default settings)
24.o.7	1200	odd	7	2
3.n.8	300	no	8	1
6.n.8	600	no	8	1
12.n.8	1200	no	8	1
24.n.8	2400	no	8	1

General Message Format:

#[controller id][command][parameter number]<new value><units>[CR/LF]

Definitions:

– This character initiates an "escape sequence" that the controller will recognize.

[controller id] – Up to 2 numeric characters, 00 to 99 (factory default = 01)

[command] – 1 character, upper case or lower case

R – To read a parameter from the controller

M – To temporarily modify a controller parameter (lost upon shutdown)

E – To modify a controller parameter in non-volatile memory (saved even after shutdown)

[parameter #] – Up to 2 numeric characters, 00 to 99

<new value> – This control word is used only when entering or modifying a parameter. Up to 6 characters may be entered. The first character can be a space, a "+", or a "-". The next 4 characters are for entering the new value parameter value. Be sure to use the exact same field format as is currently being used (i.e., if the XXX.X format is used to express temperature, be sure to enter a new value that conforms to the same format).

<units> – This optional control word is used to specify units, F for °F, C for °C.

[CR/LF] – Every transmission must be terminated with a carriage return [CR] character. The line feed [LF] character is optional.

Section 5 - Maintenance

5.1 Calibration

This unit has been fine-tuned at the factory and calibrated to give optimum performance at its full temperature range. It is recommended that the unit be returned annually for re-calibration.

5.2 Cleaning

CAUTION:

Remove all electrical connections and power before attempting any maintenance or cleaning.

5.2.1 Main Body

Only a damp, soft rag with a mild cleaning solution should be used when cleaning the main body of this unit.

5.2.2 Target Plate

Do not attempt to clean the target plate. The target plate has a special coating applied and cleaning may change the emissivity and performance of your unit.

5.2.3 Fan

The fan filter should be cleaned at least monthly by washing the filter with warm water and then blowing dry with air. It can be removed by firmly pulling the black plastic frame outward. The internal protective grill that is seated against the fan can be cleaned with a soft bristle brush.

5.3 Fuse Replacement

WARNING:

Disconnect all power from source before attempting fuse replacement.

CAUTION:

For continued protection against the risk of fire, replace with only the same size, type, and fuse rating indicated here and on the rear panel of your unit.

For model **BB704** use: 1 ea. 250 VAC~, T5A (Time-Lag, 5 Amp)
UL/CSA APPROVED (0.25" dia. x 1.25" long).

For model **BB704-230VAC** use: 2 ea. 250 VAC~, F3.5A (Fast-Acting, 3.15 Amp)
VDE APPROVED (5 mm dia. x 20 mm long).

Section 6 - Reference Probe

An RTD probe has been embedded into the target plate heater assembly to be used as a reference to check the calibrator's calibration and accuracy. A connector has been provided with your calibrator for connection to this reference probe. Listed below are a few calibration points and the resistance readings you can expect from the reference probe.

Target Plate Temperature	Reference Probe Resistance (Ohms)
100°C (212°F)	138.51
149°C (300°F)	156.96
204°C (400°F)	177.33
260°C (500°F)	197.71
316°C (600°F)	217.73
371°C (700°F)	237.05
399°C (750°F)	246.71

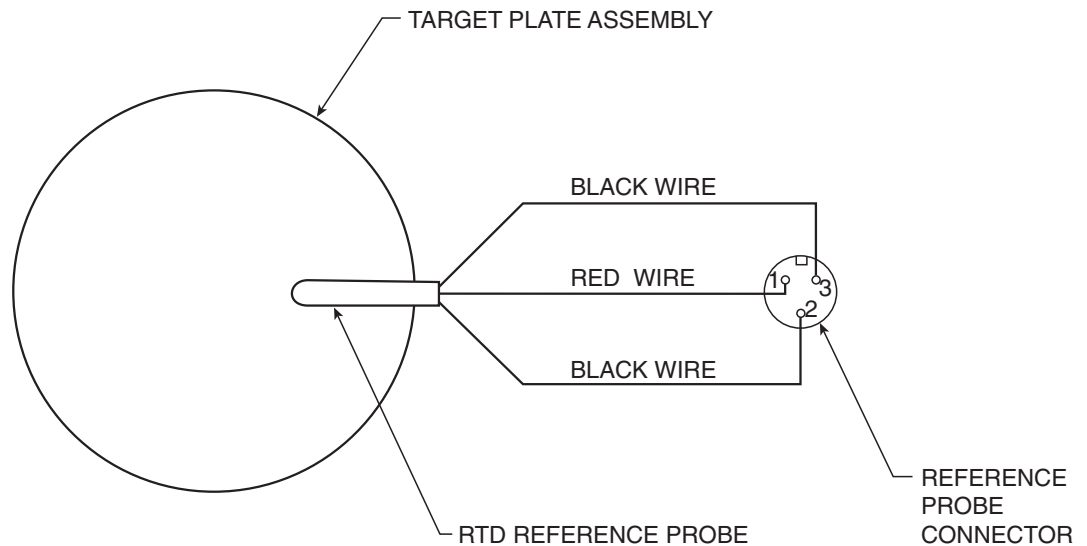





Figure 8. Internal Reference Probe Connections

Section 7 - Specifications

Target Plate Temperature Range:	100 to 398°C (212 to 750°F)
Overall Accuracy:	±0.8°C (±1.4°F)
Display Accuracy:	±0.5°C (±1.0°F)
Stability:	±0.1°C or less (±0.2°F or less)
Ambient Environmental Conditions:	
Temperature:	0 to 50°C (32 to 122°F)
Humidity:	0 to 90% RH, Non-condensing
Target Plate Size:	101.6 mm (4")
Cavity Emissivity:	0.95*
Internal Control Sensor:	RTD, Class A, Alpha = 0.00385
Reference Sensor:	RTD, Class A, Alpha = 0.00385
Accuracy:	±1.8°F (±1.0°C)
Warm-up Time:	See Table, Page 3-5
Cool-down Time:	See Table, Page 3-5
Power:	
BB704:	115 VAC~, 50/60 Hz, 425W
BB704-230 VAC:	230 VAC~, 50/60 Hz, 425W
Dimensions:	190 mm H x 410 mm W x 264 mm L (7.5" H x 16.1" W x 10.4" L)
Weight:	7.2kg (16 lbs)
Certifications:	CE (BB704-230 VAC Only)
Installation Category II	

* Reference to 8-14 microns wavelength bandwidth.

Section 8 - Troubleshooting Guide

Problem	Solution
1. Unit will not turn on.	<ul style="list-style-type: none"> a. Check all electrical connections. b. Check rear panel fuses. c. If previous steps don't solve the problem, contact our customer service department.
2. Unit turns on but the target plate will not get hot.	<ul style="list-style-type: none"> a. Check that you have entered a setpoint above the ambient temperature. b. Verify that the controller is set to its factory default settings. c. Unit may have been operated outside of operating range. The controller alarm may have disabled the heater. Let the unit cool down completely. Turn the power off and back on. If the problem is not corrected, contact the factory. d. Unit may have been operated outside of operating range. Safety cutoff switch may have disabled heater. Let the unit cool down completely. Press the reset switch located on the left side of the unit, behind the carry handle, until a click is heard. If the problem is not corrected, contact the factory. e. If previous steps don't solve the problem, contact our customer service department.
3. Controller display shows "Error" and the target plate will not get hot or cold.	<ul style="list-style-type: none"> a. Unit requires service; contact our customer service department.
4. Target plate temperature will not stabilize to within $\pm 0.5^{\circ}\text{F}$ of the setpoint temperature.	<ul style="list-style-type: none"> a. Verify that the controller is set to its factory default settings. b. If previous steps don't solve the problem, contact our customer service department.
5. Controller has no output. Pressing buttons has no effect. TUNE blinks on the display.	<ul style="list-style-type: none"> a. Controller may be in STANDBY mode. Hold down the  key continuously until "TUNE" stops blinking.
6. Controller has no output. Controller does not respond to any key presses.	<ul style="list-style-type: none"> a. Controller may be in LOCK mode. Hold down the  key continuously until "Ac.Cd" is displayed. Change to a menu level other than level 1 and exit the menu selection mode by pressing the  key once.

Section 9 - Glossary of Terms Used in This Manual

Blackbody

A theoretical object that radiates the maximum amount of energy at a given temperature, and absorbs all the energy incident upon it.

Calibration

The process of adjusting an instrument or compiling a deviation chart so that its reading can be correlated to the actual value being measured.

Emissivity

The ratio of energy emitted by a surface to the energy emitted by a blackbody at the same temperature.

IEC

International Electrotechnical Commission.

Infrared (IR)

A range of the electromagnetic spectrum extending beyond red visible light from 760 nanometers to 1000 microns.

PID

Proportional, Integral, Derivative. A three-mode control action where the controller has time proportioning, integral (auto reset), and derivative rate action.

RTD

Resistance temperature detector.

The OMEGA® Family of Blackbody Calibrators

Listed below is a selection guide to OMEGA's current line of blackbody calibration sources including the one you have selected. This family of rugged, portable, and accurate calibrators covers a wide range of temperatures, target plate sizes, and features, making them perfect for infrared pyrometer field service testing and laboratory calibrations.

BB701 Hot/Cold Blackbody Calibration Source

Calibration Range: -18 to 149°C (0 to 300°F)

Emissivity: 0.95

Cavity Size: 63.5 mm (2.5 in.)

Accuracy: ±0.8°C (±1.4 °F)

Ambient Temp.: 4 to 43°C (40 to 110°F)

Power: 115/230V, 50/60 Hz, 175W

BB702 Blackbody Calibration Source

Calibration Range: 32 to 215°C (amb. 90 to 420°F)

Emissivity: 0.95

Cavity Size: 63.5 mm (2.5 in.)

Accuracy: ± 0.5°C (±0.9°F), ±0.25% rdg

Ambient Temp.: 5 to 45°C (41 to 113°F)

Power: 115/230V, 50/60 Hz, 175W

BB703 Mini Blackbody Calibration Source

Calibration Range: 32 to 400°C (90 to 752°F)

Emissivity: 0.95

Cavity Size: 28.6 mm (1.125 in.)

Accuracy: ±1.4°C (±2.5°F)

Ambient Temp.: 0 to 40°C (32 to 104°F)

Power: 115/230V, 50/60 Hz, 175W

BB704 4" Target Plate Blackbody Calibration Source

Calibration Range: 100 to 398°C (212 to 750°F)

Emissivity: 0.95

Cavity Size: 101.6 mm (4 in.)

Accuracy: ±0.8°C (±1.4°F)

Ambient Temp.: 0 to 50°C (32 to 122°F)

Power: 115/230V, 50/60 Hz, 425W

BB705 Laboratory Grade Blackbody Calibration Source

Calibration Range: 100 to 1046°C (212 to 1915°F)

Emissivity: 0.99

Cavity Size: 44 mm (1.75 in.)

Accuracy: ±1.0°C (±1.8°F), ±0.25% rdg

Ambient Temp.: 0 to 35°C (32 to 95°F)

Power: 115/230V, 50/60 Hz, 1100W

BB-4A High Temperature Blackbody Calibration Source

Calibration Range: 100 to 982°C (212 to 1800°F)

Emissivity: 0.99

Cavity Size: 22.2 mm (0.88 in.)

Accuracy: ±1.0°C (±1.8°F), ±0.25% rdg

Ambient Temp.: 0 to 50°C (32 to 122°F)

Power: 115/230V, 50/60 Hz, 400W

For a complete, updated specification sheet and price on any of the calibrators listed here, visit our web site at omega.com. Please call our sales or customer service department for information and pricing on any new models available.



WARRANTY/DISCLAIMER

OMEGA ENGINEERING, INC. warrants this unit to be free of defects in materials and workmanship for a period of **25 months** from date of purchase. OMEGA's WARRANTY adds an additional one (1) month grace period to the normal **two (2) year product warranty** to cover handling and shipping time. This ensures that OMEGA's customers receive maximum coverage on each product.

If the unit malfunctions, it must be returned to the factory for evaluation. OMEGA's Customer Service Department will issue an Authorized Return (AR) number immediately upon phone or written request. Upon examination by OMEGA, if the unit is found to be defective, it will be repaired or replaced at no charge. OMEGA's WARRANTY does not apply to defects resulting from any action of the purchaser, including but not limited to mishandling, improper interfacing, operation outside of design limits, improper repair, or unauthorized modification. This WARRANTY is VOID if the unit shows evidence of having been tampered with or shows evidence of having been damaged as a result of excessive corrosion; or current, heat, moisture or vibration; improper specification; misapplication; misuse or other operating conditions outside of OMEGA's control. Components in which wear is not warranted, include but are not limited to contact points, fuses, and triacs.

OMEGA is pleased to offer suggestions on the use of its various products. However, OMEGA neither assumes responsibility for any omissions or errors nor assumes liability for any damages that result from the use of its products in accordance with information provided by OMEGA, either verbal or written. OMEGA warrants only that the parts manufactured by the company will be as specified and free of defects. OMEGA MAKES NO OTHER WARRANTIES OR REPRESENTATIONS OF ANY KIND WHATSOEVER, EXPRESSED OR IMPLIED, EXCEPT THAT OF TITLE, AND ALL IMPLIED WARRANTIES INCLUDING ANY WARRANTY OF MERCHANTABILITY AND FITNESS FOR A PARTICULAR PURPOSE ARE HEREBY DISCLAIMED. LIMITATION OF LIABILITY: The remedies of purchaser set forth herein are exclusive, and the total liability of OMEGA with respect to this order, whether based on contract, warranty, negligence, indemnification, strict liability or otherwise, shall not exceed the purchase price of the component upon which liability is based. In no event shall OMEGA be liable for consequential, incidental or special damages.

CONDITIONS: Equipment sold by OMEGA is not intended to be used, nor shall it be used: (1) as a "Basic Component" under 10 CFR 21 (NRC), used in or with any nuclear installation or activity; or (2) in medical applications or used on humans. Should any Product(s) be used in or with any nuclear installation or activity, medical application, used on humans, or misused in any way, OMEGA assumes no responsibility as set forth in our basic WARRANTY/DISCLAIMER language, and, additionally, purchaser will indemnify OMEGA and hold OMEGA harmless from any liability or damage whatsoever arising out of the use of the Product(s) in such a manner.

RETURN REQUESTS/INQUIRIES

Direct all warranty and repair requests/inquiries to the OMEGA Customer Service Department. BEFORE RETURNING ANY PRODUCT(S) TO OMEGA, PURCHASER MUST OBTAIN AN AUTHORIZED RETURN (AR) NUMBER FROM OMEGA'S CUSTOMER SERVICE DEPARTMENT (IN ORDER TO AVOID PROCESSING DELAYS). The assigned AR number should then be marked on the outside of the return package and on any correspondence.

The purchaser is responsible for shipping charges, freight, insurance and proper packaging to prevent breakage in transit.

FOR **WARRANTY** RETURNS, please have the following information available BEFORE contacting OMEGA:

1. Purchase Order number under which the product was PURCHASED,
2. Model and serial number of the product under warranty, and
3. Repair instructions and/or specific problems relative to the product.

FOR **NON-WARRANTY** REPAIRS, consult OMEGA for current repair charges. Have the following information available BEFORE contacting OMEGA:

1. Purchase Order number to cover the COST of the repair,
2. Model and serial number of the product, and
3. Repair instructions and/or specific problems relative to the product.

OMEGA's policy is to make running changes, not model changes, whenever an improvement is possible. This affords our customers the latest in technology and engineering.

OMEGA is a registered trademark of OMEGA ENGINEERING, INC.

© Copyright 2005 OMEGA ENGINEERING, INC. All rights reserved. This document may not be copied, photocopied, reproduced, translated, or reduced to any electronic medium or machine-readable form, in whole or in part, without the prior written consent of OMEGA ENGINEERING, INC.

Where Do I Find Everything I Need for Process Measurement and Control? **OMEGA...Of Course!** *Shop online at omega.com*

TEMPERATURE

- ☑ Thermocouple, RTD & Thermistor Probes, Connectors, Panels & Assemblies
- ☑ Wire: Thermocouple, RTD & Thermistor
- ☑ Calibrators & Ice Point References
- ☑ Recorders, Controllers & Process Monitors
- ☑ Infrared Pyrometers

PRESSURE, STRAIN AND FORCE

- ☑ Transducers & Strain Gages
- ☑ Load Cells & Pressure Gages
- ☑ Displacement Transducers
- ☑ Instrumentation & Accessories

FLOW/LEVEL

- ☑ Rotameters, Gas Mass Flowmeters & Flow Computers
- ☑ Air Velocity Indicators
- ☑ Turbine/Paddlewheel Systems
- ☑ Totalizers & Batch Controllers

pH/CONDUCTIVITY

- ☑ pH Electrodes, Testers & Accessories
- ☑ Benchtop/Laboratory Meters
- ☑ Controllers, Calibrators, Simulators & Pumps
- ☑ Industrial pH & Conductivity Equipment

DATA ACQUISITION

- ☑ Data Acquisition & Engineering Software
- ☑ Communications-Based Acquisition Systems
- ☑ Plug-in Cards for Apple, IBM & Compatibles
- ☑ Datalogging Systems
- ☑ Recorders, Printers & Plotters

HEATERS

- ☑ Heating Cable
- ☑ Cartridge & Strip Heaters
- ☑ Immersion & Band Heaters
- ☑ Flexible Heaters
- ☑ Laboratory Heaters

ENVIRONMENTAL MONITORING AND CONTROL

- ☑ Metering & Control Instrumentation
- ☑ Refractometers
- ☑ Pumps & Tubing
- ☑ Air, Soil & Water Monitors
- ☑ Industrial Water & Wastewater Treatment
- ☑ pH, Conductivity & Dissolved Oxygen Instruments