



REFRIGERATION

Freestanding 36"W. Side-By-Side Refrigerator/Freezer



Standard Features & Accessories

Models include

- Total capacity—21.5 cu. ft. (608.5 L)
- 72"H./24"D.
- "Cabinet depth" design (24"-deep side panels) integrates with surrounding cabinetry—fit for replacement of most existing appliances
- Electronic controls with digital readouts maintain the temperature selection
- Frost-free refrigerator
 - o Capacity—13.5 cu. ft. (382.1 L)
 - o Four tempered glass spillproof shelves
 - o One stationary glass shelf
 - o Temperature adjustable Meat Savor™/produce drawer
 - o Two moisture adjustable see-through produce drawers
- o In-the-door dairy compartment with cover
- o Five door bins (three bins store gallon containers)
- o Separate adjustable temperature control for door bin area
- o See-through egg bin with carrier holds up to 24 eggs
- o Glass butter tray with cover
- Frost-free freezer
 - o Capacity—8.0 cu. ft. (226.4 L)
 - o Factory-installed automatic ice maker
 - o Two adjustable wire shelves
 - o Two slide-out baskets
 - o Five large door bins (three tilt outward for easy access)
 - o Adaptive defrost
- o Max ice feature
- Open door alarm sounds to warn that door has been ajar for five minutes
- High temperature alarm
- Vacation mode

Model Options



VCSF036*
Professional



DDSF036*
Designer

FINISH DETAILS FOR BOTH MODELS

- Stainless Steel (SS)
- Finish code designates door fronts. Black cabinet sides and top.

*Shown throughout with top grille kits. See **Installation Notes & Accessories** for details.





REFRIGERATION

Freestanding 36"W. Side-By-Side Refrigerator/Freezer



★ Please see Installation Notes & Accessories for important information, including handle, trim and top grille kits.

Dimensions & Specifications

PRODUCT DIMENSIONS



VCSF036
Professional



DDSF036
Designer

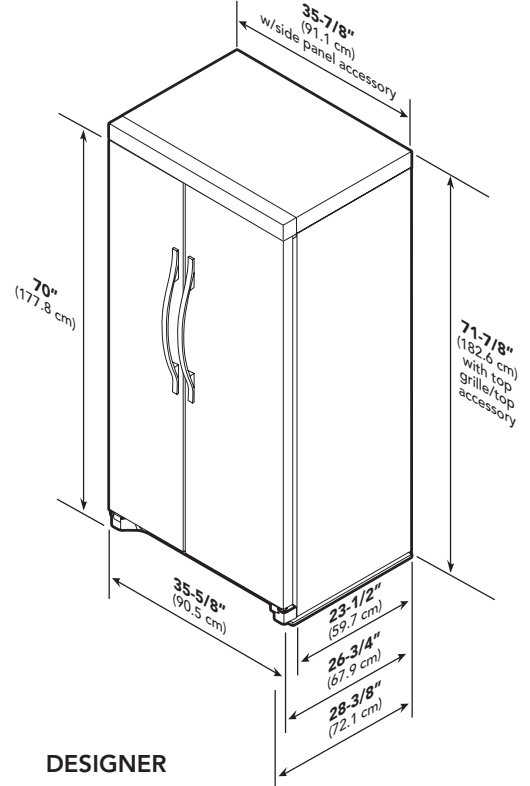
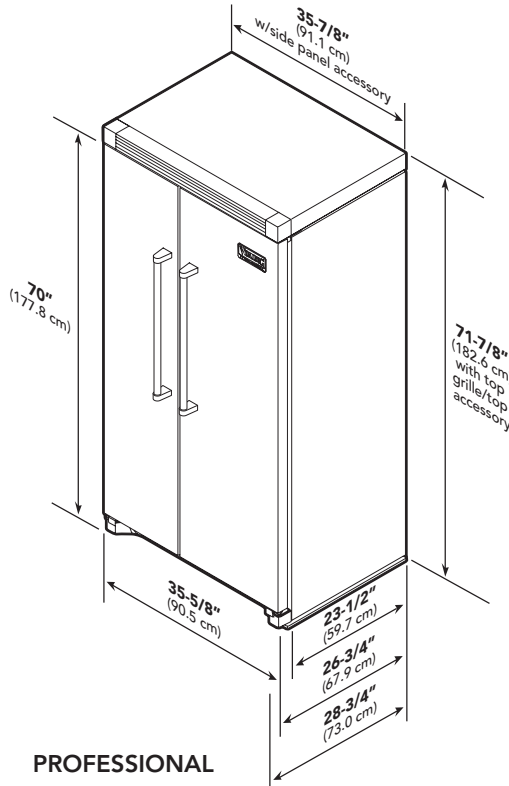

	VCSF036	DDSF036
Overall width	35-5/8" (90.5 cm)	
Addition of side panels	35-7/8" (91.1 cm)	
Overall height (from bottom)	70" (177.8 cm)	
Addition of tops/grilles	71-7/8" (182.6 cm)	
Overall depth (from rear)		
To front of door	26-3/4" (67.9 cm)	
To front of handle	28-3/4" (73.0 cm)	28-3/8" (72.1 cm)
Approx. ship weight		314 lbs. (141.3 kg)





Dimensions & Specifications

DOOR SWING



VCSF036
Professional



DDSF036
Designer

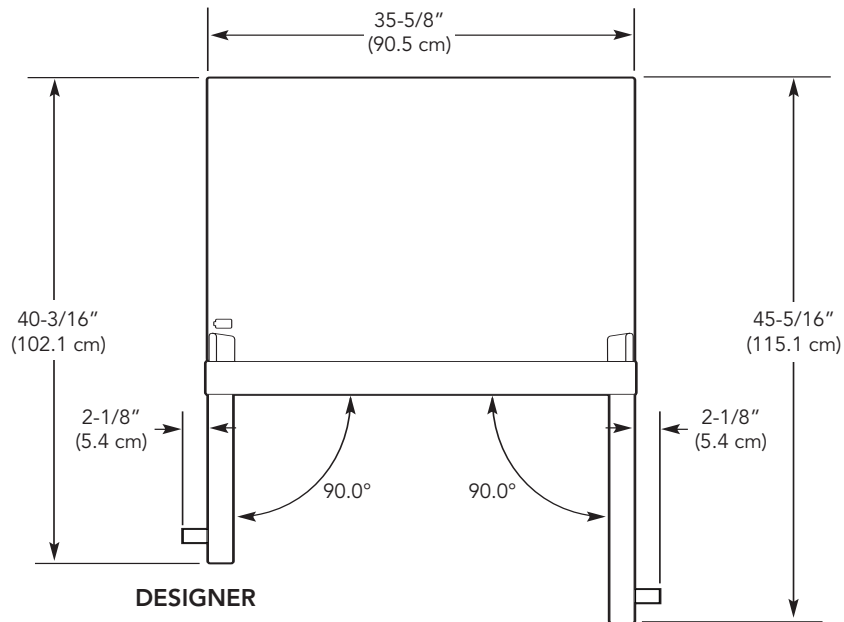
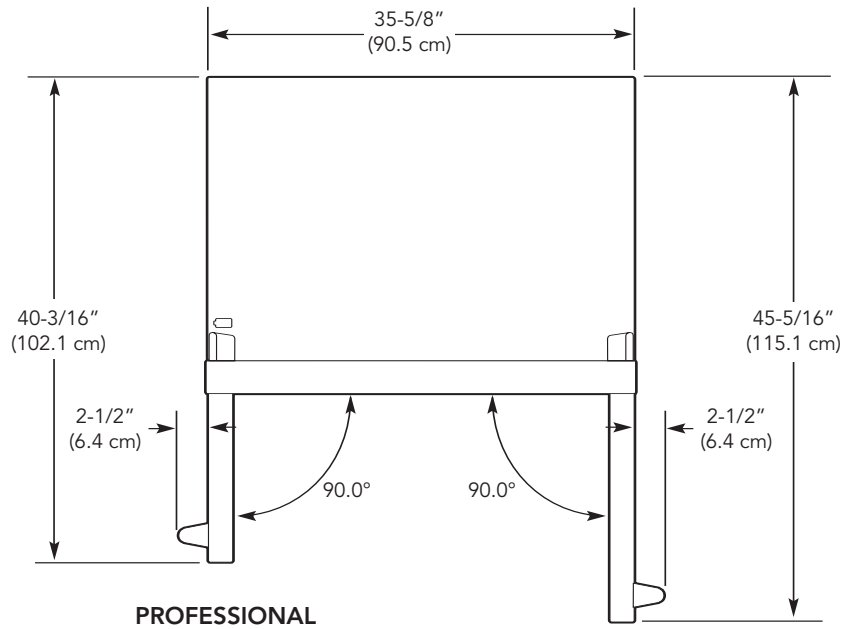



UTILITY REQUIREMENTS



GAS
Not applicable



ELECTRICAL

- Three-wire cord with grounded three-prong plug attached to product. **Do not use an extension cord or adapter plug** for a two-prong receptacle—call a qualified electrical installer.
- 115V/60 Hz; 15 amp dedicated circuit
- Maximum amp usage—7.8
- Estimated energy usage—572 kWh/year



PLUMBING

- Inlet waterline requirements—1/4" copper tubing
- 35 psi min.; 100 psi max.

Installation Requirements

ACCESS REQUIREMENTS



VCSF036
Professional



DDSF036
Designer

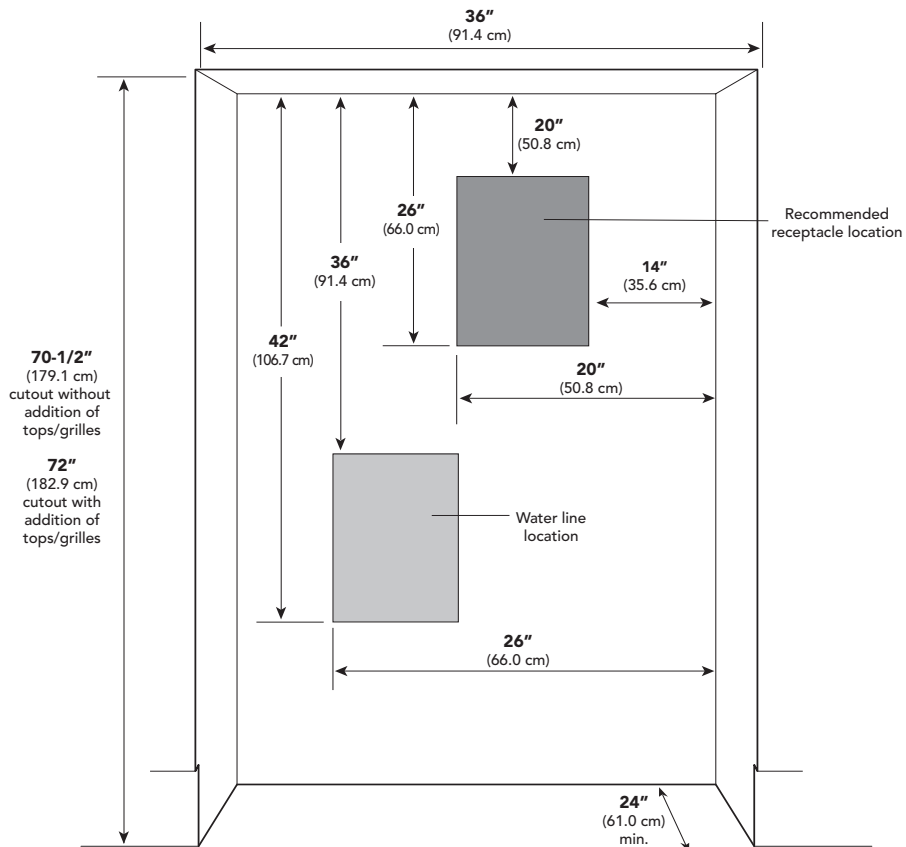

When installing into a cutout, the edge of the door must be 2-7/8" (7.3 cm) from the adjacent countertop cabinet.

Allow 1/2" (1.3 cm) space at top and 1/2" (1.3 cm) behind the machine compartment cover (located in the rear) for proper air circulation. Sub-flooring or floor coverings (i.e. carpet, tile, wood floors, rugs) may make your opening smaller than anticipated. Some clearance may be gained by using the leveling procedure under **Leveling** in the Installation Guide.

All models

Cutout width	36" (91.4 cm)
Cutout height	70-1/2" (179.0 cm)
Addition of top/grille	72" (182.9 cm)
Cutout depth	24" (61.0 cm)



REFRIGERATION

Freestanding 36"W. Side-By-Side Refrigerator/Freezer



★ Installation Notes & Accessories

Side Trim Kit

- Stainless steel finish
- Provides "built-in" look when used with a top grille kit

Model	Description	Approx. ship wt. lbs. (kg)
FRSTKS	Side-by-side side trim kit	13 (5.9)

Top Grille Kits

- Stainless steel finish
- Provides "built-in" look when used with a side trim kit; provides "wrapped" look when used with side panel and top kits

Model	Description	Approx. ship wt. lbs. (kg)
PFRGKFS	Professional side-by-side grille kit	10 (4.5)
DFRGKFS	Designer side-by-side grille kit	10 (4.5)

Side Panel Kits

- Stainless steel finish
- Provides "wrapped" look when used with top grille and top kits
- Side panel kits include panels for both sides

Model	Description	Approx. ship wt. lbs. (kg)
FRSPKS	Side-by-side side panel kit	60 (27.0)

Top Kit

- Stainless steel finish
- Provides "wrapped" look when used with side panel and top grille kits

Model	Description	Approx. ship wt. lbs. (kg)
FRTOP	Side-by-side top kit	19 (8.6)

Brass Handle Kits

- Replaces handles supplied with unit for brass trim
- Side-by-side kits include two handles

Model	Description	Approx. ship wt. lbs. (kg)
PFRHKSBR	Professional side-by-side handle kit	10 (4.5)
DFRHKBR	Designer side-by-side handle kit	10 (4.5)

Compliance Information



WARRANTY SUMMARY*

- Two-year full warranty—complete unit
- Six-year full warranty—sealed refrigeration system and automatic ice maker
- Twelve-year limited warranty—sealed refrigeration system (includes compressor, condenser, dryer/strainer, evaporator, and connecting tubing)
- Ninety-day limited warranty—cosmetic parts such as glass, painted, and decorative items

*For complete warranty see *Use & Care Guide*. Warranty valid on Viking products shipped within the United States and Canada.

