

Installed By:

Date of Commissioning:

Commissioned By:

Boost Switch Method:

Boost Switch Location:

Ensure this booklet is passed to the householder once installation and commissioning of the ventilation system is complete.

This Product Manual must be kept in the Home Information Pack and used as a service record (page 27).

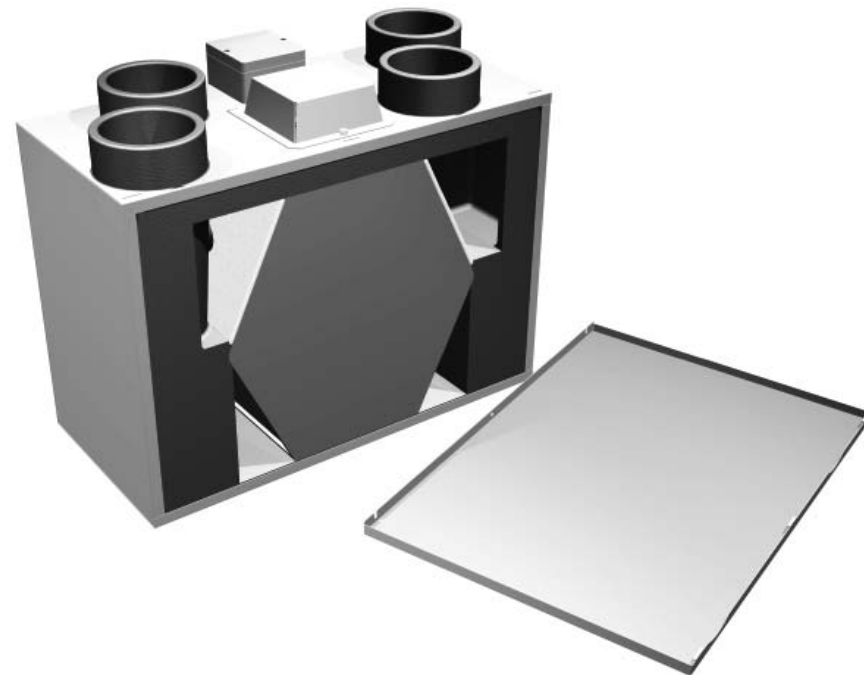

Titon HRV1 Heat Recovery Ventilation Unit

Service record

Serviced By	Company Name	Date of Service	Notes

Always ensure the service record is logged in the table above.

We declare that the equipment detailed below conforms to the requirements of EC council directives relating to electromagnetic compatibility and safety of electrical equipment.



Equipment type: Titon HRV1
Description of equipment: Mechanical ventilation unit with heat recovery
Relevant EC Council Directives: 2006/95/EC (LVD), 2004/108/EC (EMC)
Applied Harmonised Standards: EN 60335-1:2002/A2:2006
 EN 60335-2-80:2003/A1:2004

Manufacturer: Titon Hardware Limited

Signature of manufacturer representatives:

Name / Position  Date
 05 May 2009

N C Howlett
 Development and Sustainability Director

 Date
 05 May 2009

P S Cowell
 Research and Testing Manager
 BEng (Hons) CEng MCIBSE

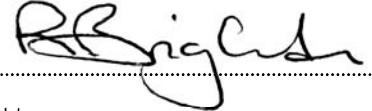
 Date
 05 May 2009

R Brighton
 Managing Director - Manufacturing Division

MARKETING DIVISION
 International House, Peartree Road, Stanway, Colchester, Essex CO3 0JL
 Tel: +44 (0) 1206 713800 Fax: +44 (0) 1206 543126 Email: enquiries@titon.co.uk Web: www.titon.com

This Product Manual only relates to the Titon HRV1 (not the Titon HRV1 Q Plus)

Section	Page Number
Introduction	4
Ventilation is vital	5
How the system works	6
How to safely use the system	7
System specification	7
Installation	8
- Dimensions	8
- Pre-installation inspection	9
- Mounting	11
- Drain assembly	13
- Ducting	15
- Electrical connections	17
- Wiring diagram	18
Commissioning	20
Service and Maintenance	24
- Cleaning	25
- Filter replacement	25
Declaration of conformity	26
Service record	27

Details Correct at the time of printing

Interior comfort, air quality and energy efficiency are vitally important considerations in buildings today.

The Titon HRV1 has been developed to meet these demands by providing clean fresh air whilst extracting stale polluted air from the building using a state of the art heat exchanger to maximise the recovery of heat from the extracted air.

For the home owner or occupant, this Product Manual explains:

- Why ventilation is vital for the good health of your home and its occupants.
- How your Titon HRV1 system works.
- How to operate and maintain your Titon HRV1.

For the professional installer, this Product Manual explains:

- How to install the Titon HRV1.
- How to commission the unit.
- How to maintain the unit.

Safety Notice

It is important to read this Product Manual to ensure your ventilation system is installed, commissioned and used properly and continues to operate effectively. Failure to follow the guidance provided in this manual can have an adverse effect on health.

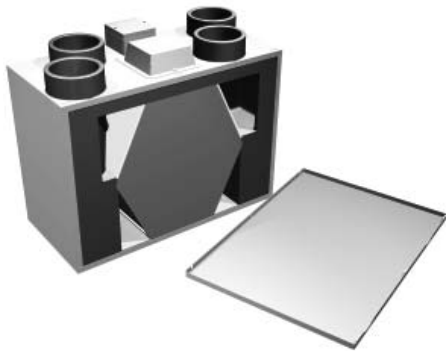

Cleaning

To clean the filters and heat exchanger:

1. Remove the front cover (see page 24).
 2. Slide out the filters that are fitted either side of the heat exchanger as shown.
 3. Remove the heat exchanger by gently pulling the plastic band around it.
 4. Clean the filters carefully using a vacuum cleaner.
 5. Carefully remove any dust from the face of the heat exchanger using a vacuum cleaner.
- Never use water or any other fluids to clean the heat exchanger.**
6. Return the heat exchanger and filters to their original position.
 7. Replace the front cover and ensure it is securely located at the top before tightening all screws.
 8. Power to the unit can now be restored.

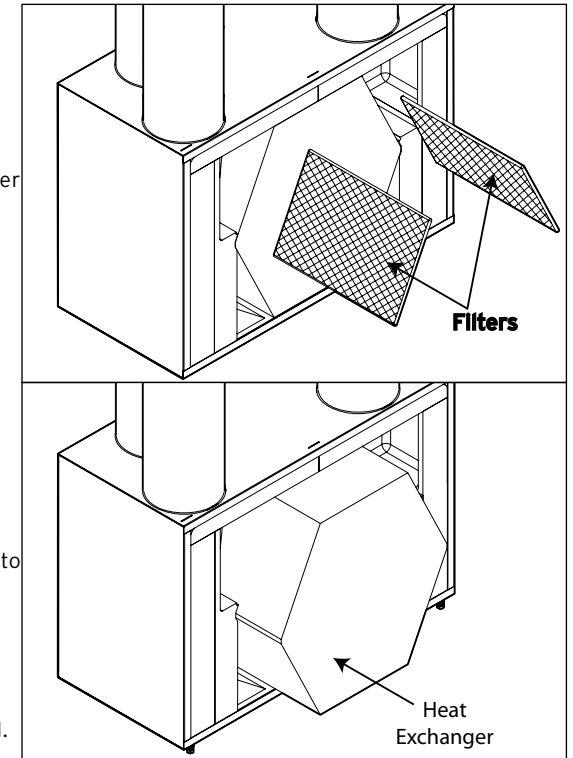

Filter replacement

Filters should be replaced annually or after a maximum of 3 cleaning cycles.

Replacement filters are available from Titon, call us on +44 (0) 1206 713800 or via www.titon.com

After servicing, always complete the service record on page 27.

WARNING: The unit uses a 230V ~ supply and contains rotating mechanical parts. ISOLATE the unit from mains power supply and allow sufficient time for all moving parts to stop before undergoing any Servicing or Maintenance.

The air filters and heat exchanger of the Titon HRV1 should be cleaned regularly by a suitably qualified person (the frequency of cleaning will vary depending on the installation environment). Filters should be replaced after a maximum of 3 cleaning cycles.

Filter and Heat Exchanger access:

1. Loosen the two corner screws located on the bottom front of the unit.

2. Remove the centre screw.

3. Completely remove the front cover by pulling it away from the unit at the bottom and lifting upwards.

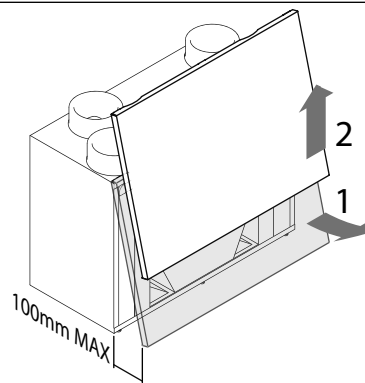
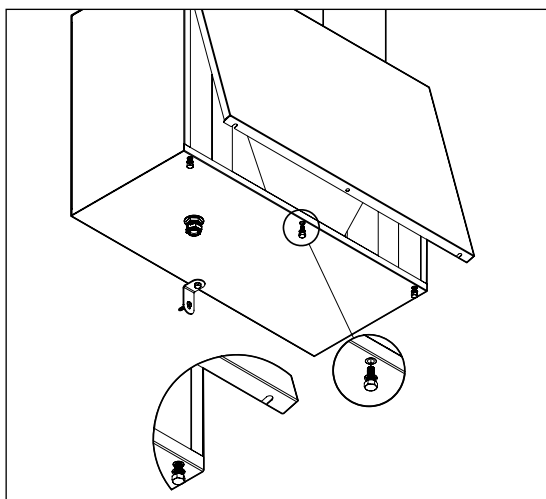

Construction methods used in older homes resulted in uncontrolled ventilation via air leaking through the building structure, such as small gaps around windows and doors or between walls and floors. These leaks allowed a large amount of air to move through a house largely unnoticed by the occupants. Other factors, such as open fireplaces, people being at home more often and opening windows to “air” rooms during daytime, all helped maintain reasonable levels of air quality in homes.

However, because this form of ventilation was uncontrolled, a large proportion of heat escaped to the outside and more fuel energy (such as coal gas or electricity) was needed to make up for this loss.

Modern homes have virtually no air leaks and combined with improved levels of insulation, the air indoors will not change without the use of products made to control ventilation.

Lack of ventilation in buildings will lead to the build up of harmful substances such as chemicals and gases which come from the everyday things we all have or use in our homes that can go unnoticed for long periods.

Moisture produced by people from breathing and carrying out ordinary activities such as washing or cleaning, can build up and cause mould, damaging the health of the occupants and the building structure. A family of four can produce up to 20 litres of water vapour everyday.

Poor ventilation can be a major contributory factor of heart disease, lung disease, mental illness and many more threats to our health.



The World Health Organisation and responsible Governments throughout the world recognise the vital importance of good indoor air quality, and that is why Regulations govern the way new houses are designed and built to ensure your health does not suffer as a result of poor ventilation. When new homes are occupied, it is then up to the people who live in them to make sure they use and maintain the ventilation products in accordance with the instructions provided.

The Titon HRV1 works by continuously extracting stale polluted air from rooms where most moisture is generated and providing fresh pre-warmed air taken from outside the house and delivering it to other rooms, creating a flow of fresh, cleaner air throughout the house.

The air travels from terminals built into the ceiling which are connected by hidden ducts to the unit. The unit is usually installed in a roof space or cupboard.

Each unit is commissioned individually so the amount of air moved is set to suit the specific size and style of the house.

Most systems will also have a facility to boost the extraction rate at times when more moisture is being generated, such as when bathing or cooking. This may be done automatically by electronic sensors or by a conveniently located boost switch for manual operation.

DO NOT switch off the unit; it is designed to run continuously. If the unit is switched off indoor pollutant and moisture levels may increase and become a danger to your health and damage your house.

It is important to follow the advice in this user manual and correctly maintain the system to ensure a healthy indoor environment.

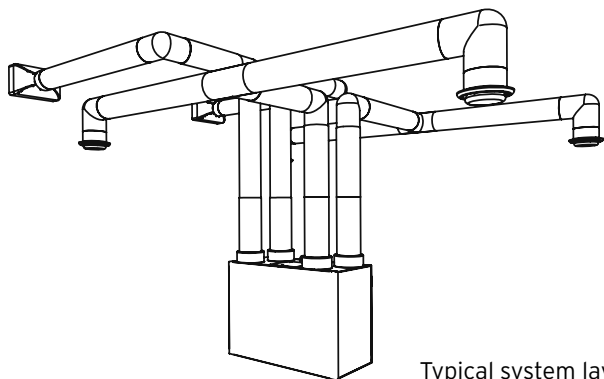

Typical system layout

The unit runs automatically and should not be switched off, except for maintenance or filter replacement.

If a boost switch has been installed, it can be used to increase the extract ventilation rate at times when moisture or pollutant levels are considered excessive.

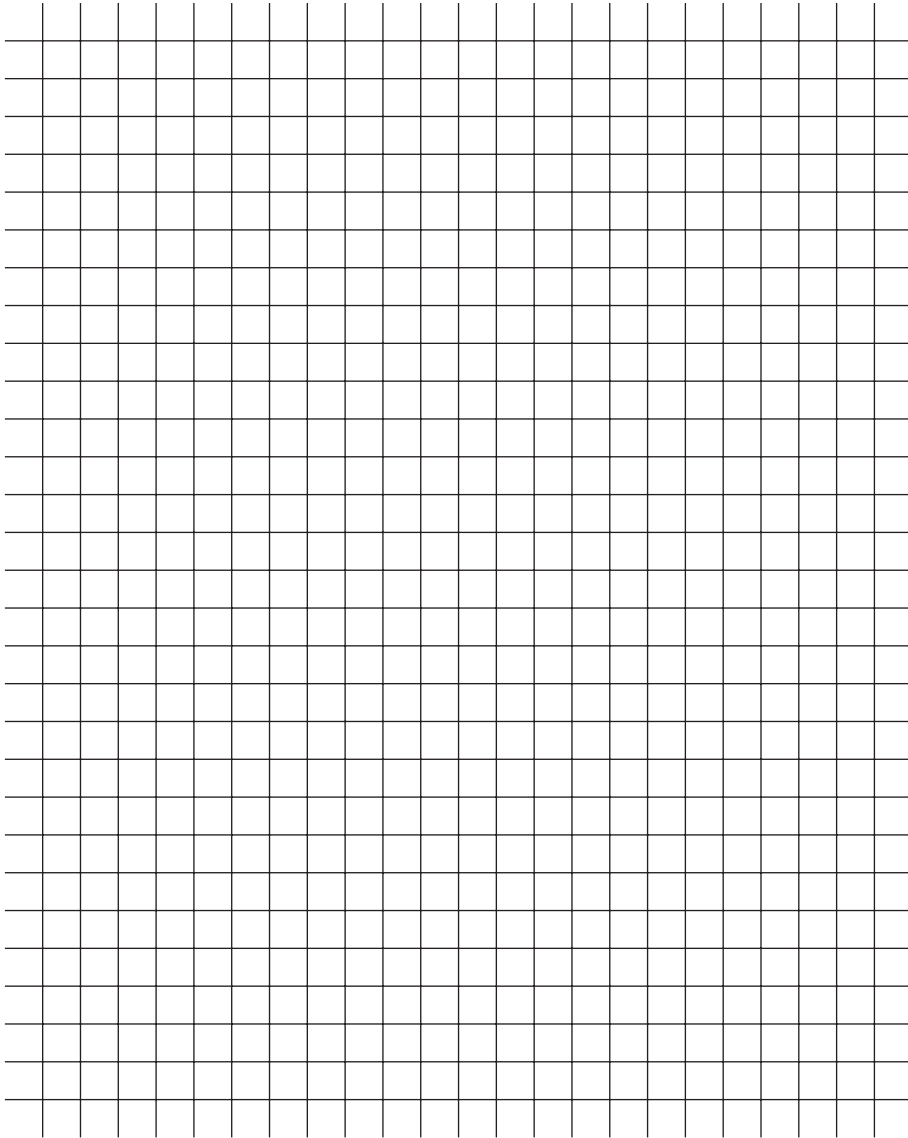

You may have electronic sensors which detect high levels of moisture and pollutants which boost the system automatically.

All whole house ventilation units require periodic maintenance and this must only be carried out by a suitably qualified and competent person. See the Servicing and Maintenance section for further details.

Features of the Titon HRV1

- Compact size.
- Easy installation mounting bracket.
- Standard 15mm fitting for condensate drain connection.
- The duct ports accept 100 and 125mm diameter ducting.
- Boost Control via a two-way switch.

Installation - before you begin

Commissioning

IMPORTANT: READ THESE INSTRUCTIONS FULLY BEFORE THE INSTALLATION OF THIS APPLIANCE!

The Titon HRV1 is designed to be fitted in to the roof space or a cupboard. These diagrams show the dimensions of the unit and the additional space required around the unit to allow for future servicing and maintenance.

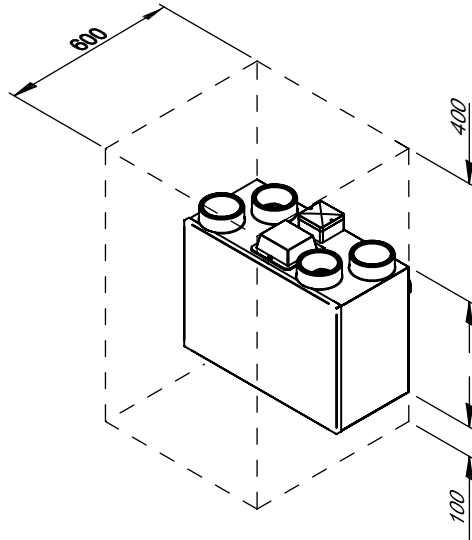

NEVER install the unit in an area which does not have sufficient access for future maintenance

NEVER install the appliance in an environment which contains:

- Excessive oil or a grease laden environment.
- Hazardous gases, liquids or vapours that are flammable or corrosive.
- Ambient temperatures above 40°C or below -5°C.
- Humidity levels above 90% or a wet environment.

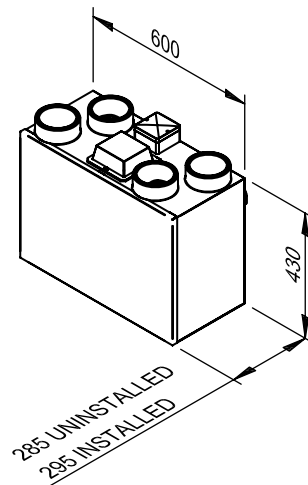

WHITE wire continuous rate, BLACK wire boost rate. Do not reposition the BROWN or BLUE wire.

Speed	Volts	Curve
1	100	-----
2	140	-----
3	160	-----
4	180	-----
5	200	-----

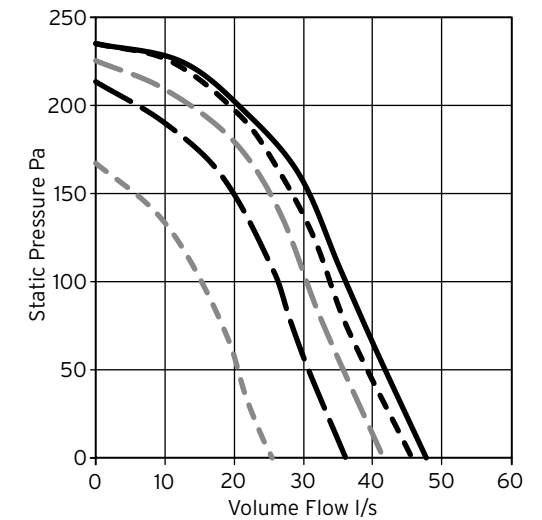

Once the appliance has been fully installed it must be commissioned

The HRV1 is Factory set at Continuous Speed 1 - 100V, Boost Speed 3 - 160V (see page 21).

Fan speeds may require adjustment in order to provide other ventilation rates more appropriate to the dwelling.

If adjustment is required follow the steps below;

- **Isolate the appliance from the mains power supply.**
- Open the transformer access panel on the top of the unit.
- Reposition the crimped connectors on the transformer to select an alternative continuous/boost speed setting. WHITE wire continuous rate, BLACK wire boost rate. Do not reposition the BLUE or BROWN wire. See page 21.
- Refit the transformer access panel and ensure that all covers and fixings are secure before reconnection of the mains power supply.
- Check the new speed settings.

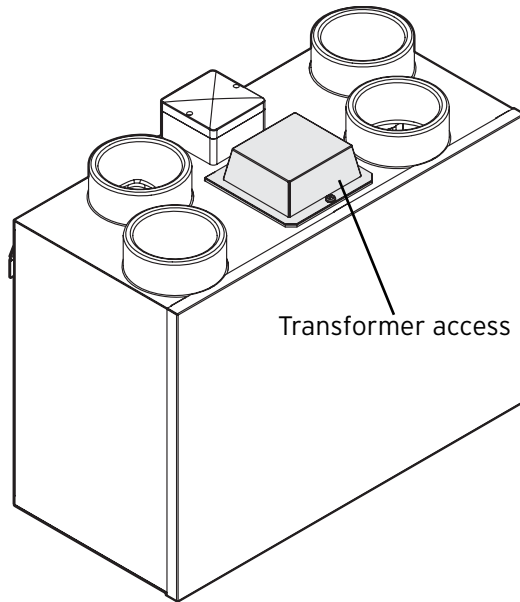

Safety and guidance

- The electrical installation of the appliance MUST be carried out by a suitably qualified competent person in accordance with current I.E.E. Regulations and all appropriate standards.
- The appliance must be connected to a local isolation switch with a contact separation of at least 3mm.
- The appliance is suitable for 230V ~ 50Hz single phase with a fuse rating of 3A.
- The condensation drain must be fitted.
- Ensure that external grills are located away from any flue outlet, in accordance with the relevant Building Regulations.
- Always ensure ducting is free from blockages before switching the unit on as this may invalidate your guarantee.
- Recommended a minimum distance of 2m between the external air supply inlet and the extract air outlet to prevent cross contamination.
- Recommend a minimum distance of 200mm between the appliance and any sharp bends in duct work.

Installation of the appliance MUST be carried out by a qualified and suitably competent person and should be carried out in clean, dry conditions where dust and humidity are at minimal levels. The appliance is not suitable for installation to the exterior of the dwelling.

Transportation, packaging and storage prior to installation

- Great care should be taken when transporting the appliance, DO NOT drop as damage may occur within the appliance.
- The unit must always be stored in a clean, dry environment.
- Remove all packaging before installation.

Pre-inspection

- Inspect the appliance for any damage.
- Check all accessories have been supplied.
- Any damage must be repaired by a suitably qualified and competent person.

Parts list

- 1 Titon HRV1 unit.
- 4 Transport Bungs
- 2 Wall mounting brackets.
- 1 Safety bracket.
- 115mm Drain connector.
- 4 M6x10mm pan head screws.
- 4 M6 washers.

Any parts shortages or faults must be reported to the supplier immediately.

Boost Control

The continuous and boost speeds of the appliance are set at installation by selecting the appropriate connections to a multi-tapped transformer located beneath the transformer access cover on the top of the unit.

- A separate terminal box is fitted on the top of the unit for connection of the mains supply and boost switch wiring. (See illustration below)
- Cable access must be via the preformed cable entries on the enclosure (suitable strain relief for the cable must be provided)
- The boost control utilises a two-way switch connection between the COM, L1 and L2 terminals (see wiring diagram on Page 18).
- The boost can be triggered by any device which provides a two-way switch suitable for a 230V mains power supply.

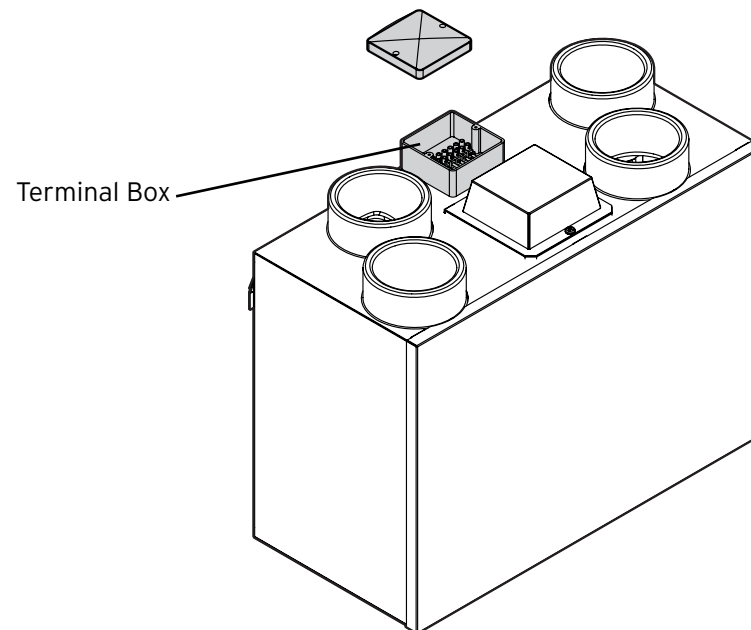

Installation - wiring

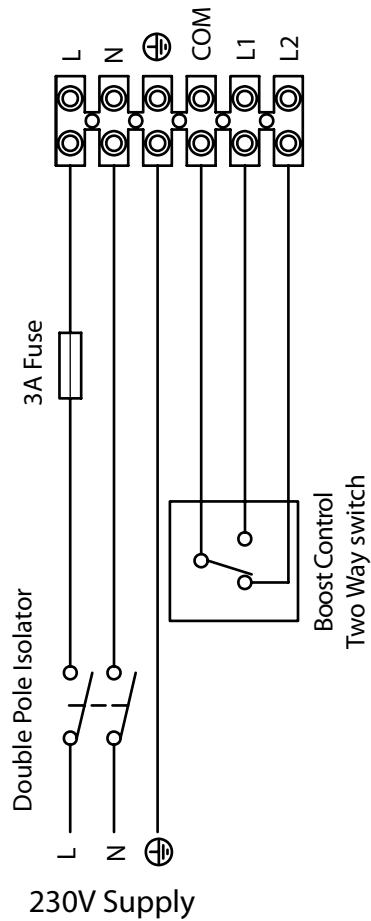

Important: Wiring must always be in accordance with the diagram above. Incorrect wiring of the unit will result in damage to the internal components and void Warranty

Installation - mounting

Do not remove the Transport Bungs until connecting ducting (see page 15). Transport bungs are fitted to prevent debris falling into the unit and causing damage. Premature removal of the transport bungs may invalidate the guarantee.

1. Mark a horizontal line on the wall using a spirit level. This line will be approximately 95mm below the location of the top face of the unit when fitted (excluding duct ports). It is recommended that this line should be 495mm below the finished ceiling level to create sufficient space above the unit for installation and maintenance.

2. Use one of the mounting brackets as a template to mark the three fixing hole centres.

3. Drill holes for fixings, always use a fixing suited to the wall type.

4. Mount one fixing bracket to the wall ensuring the interlocking side is at the top, as shown.

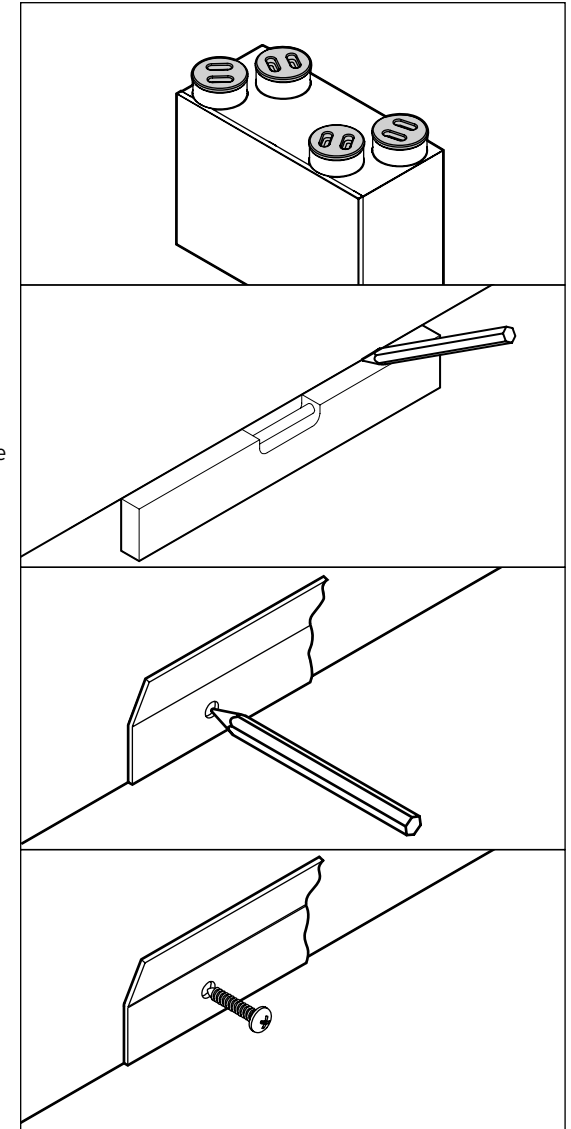

Installation - mounting

5. Fix the remaining bracket to the unit using the M6 screws and washers provided, ensuring the interlock side is at the bottom. Do not over-tighten.

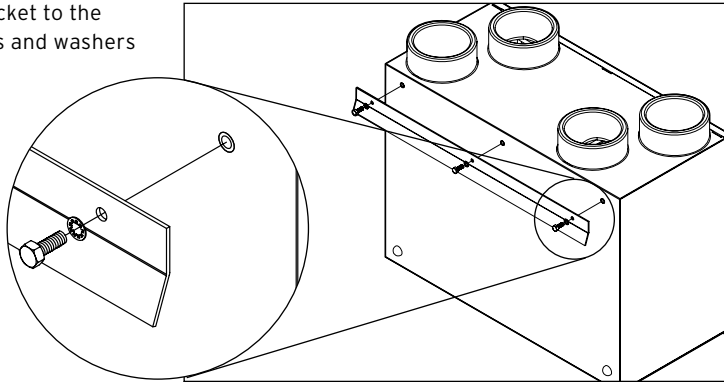

6. Mount the unit by locating the two mounting brackets together. Ensure a positive location is made between the two mounting brackets.

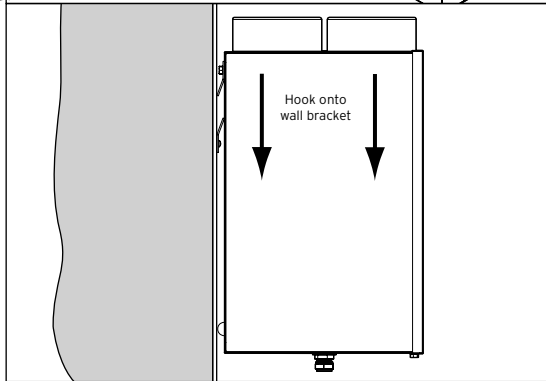

7. Fix the lower safety bracket as shown using the remaining M6 screw, washer and suitable wall fixing.

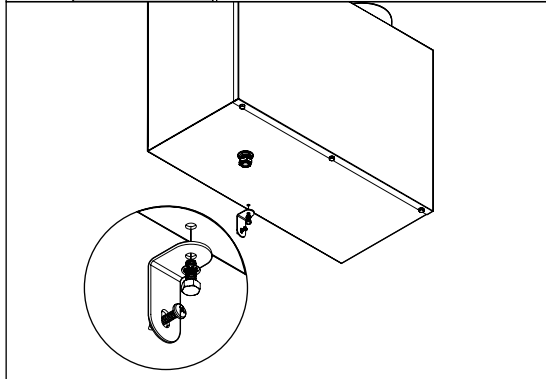

Installation - wiring

WARNING: The unit MUST be earthed. Installation must conform to current I.E.E. Regulations and all applicable standards and Building Regulations.

- The unit is suitable for 230V~50Hz Single phase supply fused at 3A.
- A terminal box is fitted on the top of the unit for connection of the mains and boost trigger switch. Note: suitable strain relief for the cable(s) must be provided by the installer.
- A double pole isolation switch with contact separation of at least 3mm must be used to connect the appliance to the fixed wiring.
- Boost controls must not be located within 1 metre of a cooker or where they may be affected by excessive heat or moisture
- Boost controls should be clearly identified and conveniently located.
- The boost switch is connected to the terminal box on the top of the unit.
- Please note that the boost switch must be connected for the unit to run, see wiring diagram on page 18 (a connection is required between COM and either L1 or L2 to operate the unit).
- The boost speed can be selected by any device which provides a two-way switch.

Installation - ducting

Ducting best practice

- The use of flexible ducting must be kept to a minimum and it should always be pulled taut.
- If applicable, Fire Dampers **MUST BE FITTED** to duct work at appropriate locations in accordance with Building Regulations.
- Ducting must be installed in such a way that resistance to airflow is minimised.
- Ducting terminals for Inlet and exhaust must be to the external air outside the building envelope.
- Inlet and exhaust ducts should be separated to ensure there is no cross contamination of air.
- Ducting in unheated spaces must always be insulated to prevent condensation forming within the ducting.
- Ducting joints must be permanently sealed with quality ducting tape and/or silicone type sealant.
- Recommended a minimum distance of 2m between the external air supply inlet and the extract air outlet to prevent cross contamination.

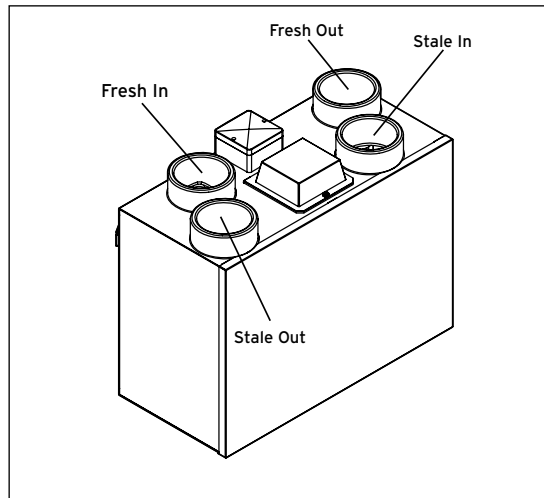

Installation - drain assembly

A drain must be connected to allow condensation to be removed from the unit.

The drain connection is made via the 15mm connection on the base of the unit.

The drain must discharge into the household drainage system via a U-bend, which must act as an air lock.

1. Remove front cover (see page 24).

2. Insert the drain connector through the base of the unit from the inside. Ensure the drain connector forms a seal with the moulded drain tray, applying silicone sealant if necessary.

(The heat exchange cube and filters have been removed for illustrative purposes only).

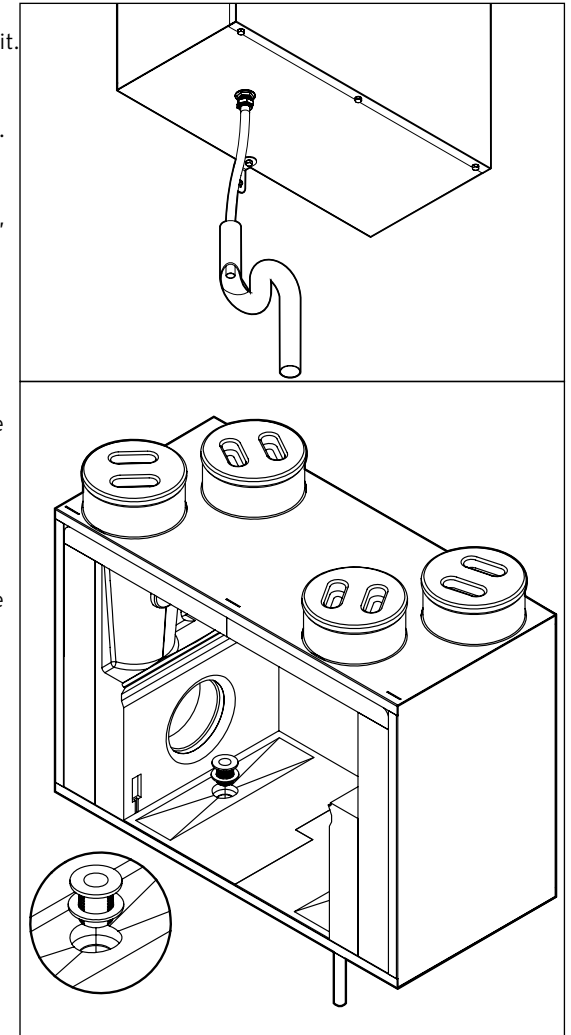

Installation - drain assembly

2. Assemble the drain as indicated through the bottom of the unit.

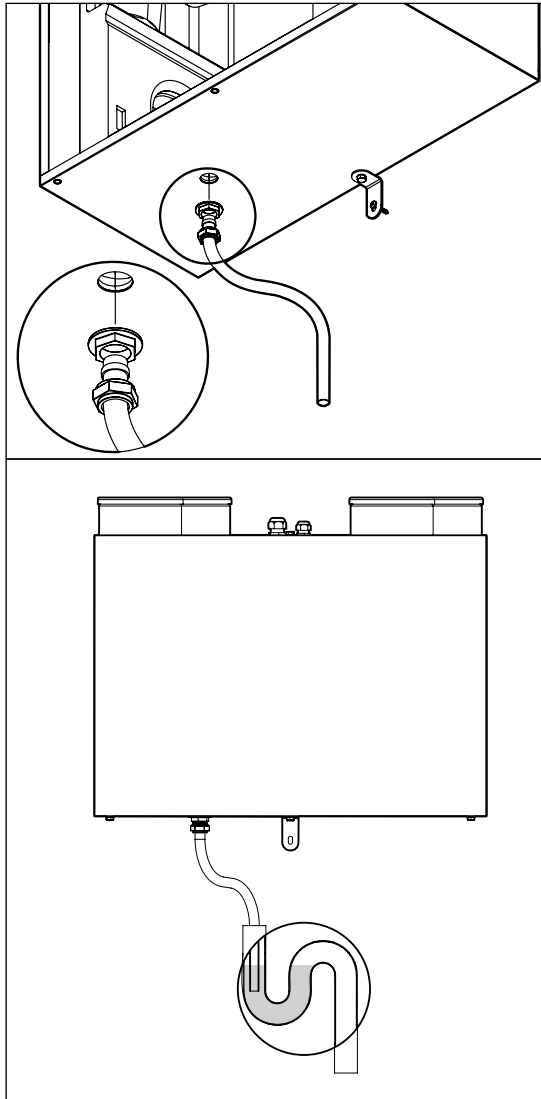

Important note: The drain must incorporate a U-bend to prevent air penetration.

1. When the ducting has been installed and you are ready to connect the unit, remove the

Installation - ducting

transport bungs from the duct ports.

125mm ducting fits to the outer of the duct ports as shown.

100mm ducting fits to the inner of the duct ports as shown.

