

STIHL[®]

STIHL MS 311, 391

Instruction Manual



Contents

Guide to Using this Manual	2	Main Parts	41
Safety Precautions and Working Techniques	2	Specifications	42
Cutting Attachment	14	Special Accessories	43
Mounting the Bar and Chain	14	Ordering Spare Parts	44
Tensioning the Chain	15	Maintenance and Repairs	44
Checking Chain Tension	15	EC Declaration of Conformity	44
Fuel	16	Quality Certification	45
Fueling	17		
Chain Lubricant	18		
Filling Chain Oil Tank	19		
Checking Chain Lubrication	19		
Chain Brake	20		
Winter Operation	21		
Starting / Stopping the Engine	22		
Operating Instructions	25		
Oil Quantity Control	26		
Taking Care of the Guide Bar	26		
Air Filter System	27		
Cleaning the Air Filter	27		
Adjusting the Carburetor	28		
Spark Arresting Screen in Muffler	29		
Spark Plug	30		
Replacing the Starter Rope and Rewind Spring	31		
Storing the Machine	33		
Checking and Replacing the Chain Sprocket	33		
Maintaining and Sharpening the Saw Chain	34		
Maintenance and Care	38		
Minimize Wear and Avoid Damage	40		

Dear Customer,

Thank you for choosing a quality engineered STIHL product.

This machine has been built using modern production techniques and comprehensive quality assurance. Every effort has been made to ensure your satisfaction and troublefree use of the machine.

Please contact your dealer or our sales company if you have any queries concerning your machine.

Your



Hans Peter Stihl



STIHL®

MS 311, MS 391

Guide to Using this Manual

Pictograms

Pictograms that appear on the machine are explained in this Instruction Manual.

Depending on the machine and equipment version, the following pictograms may appear on the machine.



Fuel tank; fuel mixture of gasoline and engine oil



Tank for chain oil; chain oil



Engage and release chain brake



Coasting brake



Direction of chain travel



Ematic; chain oil flow adjustment



Tension saw chain



Intake air baffle: winter operation



Intake air baffle: summer operation



Handle heating

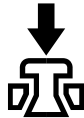

Actuate decompression valve

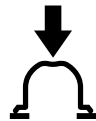

Actuate manual fuel pump

Symbols in text



Warning where there is a risk of an accident or personal injury or serious damage to property.



Caution where there is a risk of damaging the machine or its individual components.

Engineering improvements

STIHL's philosophy is to continually improve all of its products. For this reason we may modify the design, engineering and appearance of our products periodically.

Therefore, some changes, modifications and improvements may not be covered in this manual.

Safety Precautions and Working Techniques



Because a chain saw is a high-speed wood-cutting tool with very sharp cutters, some special safety precautions must be observed in addition to those that generally apply when working with an axe or hand saw.



It is important you read and understand the instruction manual before using your power tool for the first time and keep the manual in a safe place for future reference. Non-observance of the safety precautions may result in serious or even fatal injury.

Observe all applicable local safety regulations, standards and ordinances.

If you have not used this type of power tool before: Have your dealer or other experienced user show you how to operate your power tool or attend a special course in its operation.

Minors should never be allowed to use a power tool.

Keep bystanders, especially children, and animals away from the work area.

When the power tool is not in use, shut it off so that it does not endanger others. Secure it against unauthorized use.

The user is responsible for avoiding injury to third parties or damage to their property.

Do not lend or rent your power tool without the instruction manual. Be sure that anyone using it understands the information contained in this manual.

The use of noise emitting power tools may be restricted to certain times by national or local regulations.

To operate the power tool you must be rested, in good physical condition and mental health. If you have any condition that might be aggravated by strenuous work, check with your doctor before operating a power tool.

Persons with pacemakers only: The ignition system of your power tool produces an electromagnetic field of a very low intensity. This field may interfere with some pacemakers. To reduce health risks, STIHL recommends that persons with pacemakers consult their physician and the pacemaker manufacturer before operating this tool.

Do not operate the power tool if you are under the influence of any substance (drugs, alcohol) which might impair vision, dexterity or judgment.

To reduce the risk of accidents or injury, put off the work in poor weather conditions (rain, snow, ice, wind).

Use your saw for cutting wood or wooden objects only.

Do not use your power tool for any other purpose since **this may result in accidents**.

Only use tools, guide bars, chains, chain sprockets and accessories that are explicitly approved for this power tool model by STIHL or are technically identical. If you have any questions in this respect, consult a servicing dealer.

Use only high quality parts and accessories in order to avoid the risk of accidents and damage to the machine.

STIHL recommends the use of STIHL original tools, guide bars, chains, chain sprockets and accessories. They are specifically designed to match your model and meet your performance requirements.

Never attempt to modify your power tool in any way since this may increase the risk of personal injury. STIHL excludes all liability for personal injury and damage to property caused while using unauthorized attachments.

Do not use a pressure washer to clean the unit. The solid jet of water may damage parts of the unit.

Clothing and Equipment

Wear proper protective clothing and equipment.



Clothing must be sturdy but allow complete freedom of movement. Wear snug-fitting clothing with **cut retardant inserts** – an overall and jacket combination, do not wear a work coat.

Avoid clothing that could get caught on branches or brush or moving parts of the machine. Do not wear a scarf, necktie or jewelry. Tie up and confine long hair (e.g. with a hair net, cap, hard hat, etc.).



Wear steel-toed **safety boots** with cut retardant inserts and non-slip soles.



Wear a **safety hard hat** where there is a danger of head injuries from falling objects.

Wear **safety glasses** or a **face shield** and **hearing protection** e.g. earplugs or ear muffs.



Wear **heavy-duty gloves**.

STIHL offers a comprehensive range of personal protective clothing and equipment.

Transporting the Chain Saw

Always engage the chain brake and fit the chain guard (scabbard) before carrying the saw short distances. Also stop the engine before carrying the saw longer distances (more than about 50 m).

Always carry the saw by the front handle (handlebar) – with the hot muffler away from your body – the guide bar must point to the rear. To **avoid serious burn injuries**, avoid touching hot parts of the machine, especially the surface of the muffler.

Transporting in a vehicle: Properly secure your power tool to prevent turnover, fuel spillage and damage.

Fueling



Gasoline is an extremely flammable fuel. Keep clear of naked flames. Do not spill any fuel – do not smoke.

Always shut off the engine before refueling.

Do not fuel a hot engine – **fuel may spill and cause a fire.**

Open the fuel cap carefully to allow any pressure build-up in the tank to release slowly and avoid fuel spillage.

Fuel your power tool only in well-ventilated areas. If you spill fuel, wipe the machine immediately – if fuel gets on your clothing, change immediately.

Your power tool comes standard with either a screw-type or bayonet-type fuel cap.



After fueling, tighten down the screw-type fuel cap as securely as possible.



Insert the fuel cap with hinged grip (bayonet-type cap) correctly in the opening, turn it clockwise as far as stop and fold the grip down.

This reduces the risk of unit vibrations causing the fuel cap to loosen or come off and spill quantities of fuel.

Before starting

Check that your power tool is properly assembled and in good condition – refer to appropriate chapters in the instruction manual.

- Check operation of chain brake, front hand guard
- Correctly mounted guide bar
- Correctly tensioned chain
- Smooth action of throttle trigger and throttle trigger interlock – throttle trigger must return automatically to idle position.
- Master Control lever / stop switch must move easily to **STOP** or **0**
- Check that the spark plug boot is secure – a loose boot may cause arcing that could ignite combustible fumes **and cause a fire.**
- Never attempt to modify the controls or the safety devices in any way.
- Keep the handles dry and clean – free from oil and pitch – for safe control of the chain saw.

To reduce the risk of personal injury, do not operate your saw if it is damaged or not properly assembled.

Starting the engine

Start the engine at least 3 meters from the fueling spot, outdoors only.

Place the unit on firm ground in an open area. Make sure you have good balance and secure footing. Hold the unit securely. The cutting attachment must

be clear of the ground and all other obstructions because it may begin to run when the engine starts.

Your chain saw is designed to be operated by one person only. Do not allow other persons in the work area – even when starting.

To reduce risk of chain rotation and personal injury, lock the chain with the chain brake before starting.

Do not drop start your machine – the correct starting procedure is described in the instruction manual.

Do not attempt to start the saw when the saw chain is in a cut.

Holding and Controlling the Power Tool

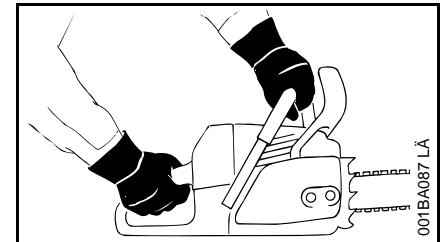

Always **hold your saw firmly with both hands:** Right hand on the rear handle, even if you are left-handed. To ensure safe control, wrap your fingers tightly around the front and rear handles.

During Operation

Make sure you always have good balance and secure footing.

In the event of impending danger or in an emergency, switch off the engine immediately by moving the Master Control lever / stop switch to **STOP** or **0**.

Your power tool is designed to be operated by one person only. Do not allow other persons in the work area.

Never leave a running machine unattended.

When the engine is running: Note that the chain continues to rotate for a short period after you let go of the throttle trigger (flywheel effect).

Take special care in slippery conditions – damp, snow, ice, on slopes, uneven ground and freshly debarked logs.

Watch out for obstacles such as tree stumps, roots and ditches which could cause you to trip or stumble.

Do not work alone – keep within calling distance of others in case help is needed.

Be particularly alert and cautious when wearing hearing protection because your ability to hear warnings (shouts, alarms, etc.) is restricted.

To reduce the risk of accidents, take a break in good time to avoid tiredness or exhaustion.

To reduce risk of fire, keep hot exhaust gases and hot muffler away from easily combustible materials (e.g. wood chips, bark, dry grass, fuel). Mufflers with a catalytic converter can become particularly hot.



Your power tool produces toxic exhaust fumes as soon as the engine is running. These fumes may be colorless and odorless and contain unburned hydrocarbons and benzol. Never run the engine indoors or in poorly ventilated locations, even if your model is equipped with a catalytic converter.

To reduce the risk of serious or fatal injury from breathing toxic fumes, ensure proper ventilation when working in trenches, hollows or other confined locations.

To reduce the risk of accidents, stop work immediately in the event of nausea, headache, visual disturbances (e.g. reduced field of vision), problems with hearing, dizziness, deterioration in ability to concentrate. Apart from other possibilities, these symptoms may be caused by an excessively high concentration of exhaust gases in the work area.

The dusts (e.g. sawdust), vapor and smoke produced during operation may be dangerous to health. If dust levels are very high, wear a suitable respirator.

Check the saw chain at regular short intervals during operation or immediately if there is a noticeable change in cutting behavior:

- Shut off the engine and wait until the chain comes to a complete standstill.
- Check condition
- Check sharpness.

Do not touch the chain while the engine is running. If the chain becomes jammed by an obstruction, switch off the engine immediately before attempting to remove the obstruction.

To reduce the risk of injury, shut off the engine before changing the saw chain.

To reduce the risk of fire, do not smoke while operating or standing near your power tool. Note that combustible fuel vapor may escape from the fuel system.

If your power tool is subjected to unusually high loads for which it was not designed (e.g. heavy impact or a fall), always check that it is in good condition before continuing work – see also "Before Starting". Check the fuel system in particular for leaks and make sure the safety devices are working properly. Do not continue operating your power tool if it is damaged. In case of doubt, have the machine checked by your servicing dealer.

Make sure the idle speed setting is correct. The chain must not run when the engine is idling with the throttle trigger released. Check and correct the idle speed setting at regular intervals. If the saw chain still moves, have your dealer check your machine and make proper adjustments or repairs.

Reactive Forces

The most common reactive forces that occur during cutting are: kickback, pushback and pull-in.

Dangers of kickback



Kickback can result in serious or fatal injury.

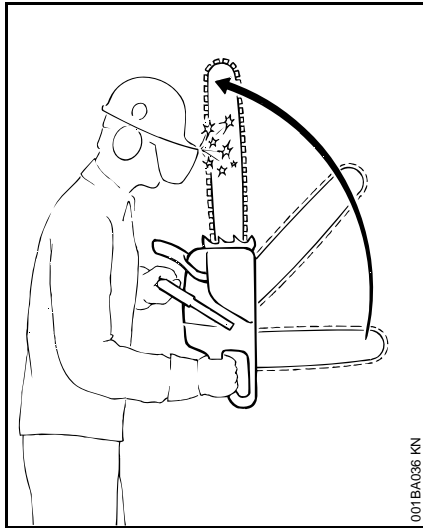

Kickback occurs when the saw is suddenly thrown up and back in an uncontrolled arc towards the operator.

Kickback occurs, e.g.

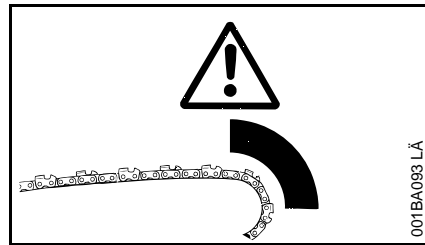

- when the upper quadrant of the bar nose unintentionally contacts wood or another solid object, e.g. when another limb is touched accidentally during limbing.
- when the chain at the nose of the guide bar is pinched in the cut.

Quickstop chain brake:

This device reduces the risk of injury in certain situations – it cannot prevent kickback. If activated, the brake stops the saw chain within a fraction of a second – for a description of this device refer to chapter on "Chain Brake" in this manual.

To reduce the risk of kickback

- Work cautiously and avoid situations which could cause kickback.
- Hold the saw firmly with both hands and maintain a secure grip.
- Always cut at full throttle.
- Be aware of the location of the guide bar nose at all times.
- Do not cut with the bar nose.
- Take special care with small, tough limbs, they may catch the chain.

- Never cut several limbs at once.
- Do not overreach.
- Never cut above shoulder height.
- Use extreme caution when re-entering a previous cut.
- Do not attempt plunge cuts if you are not experienced in this cutting technique.
- Be alert for shifting of the log or other forces that may cause the cut to close and pinch the chain.
- Always cut with a correctly sharpened, properly tensioned chain – the depth gauge setting must not be too large.
- Use a low kickback chain and a narrow radius guide bar.

Pull-in (A)

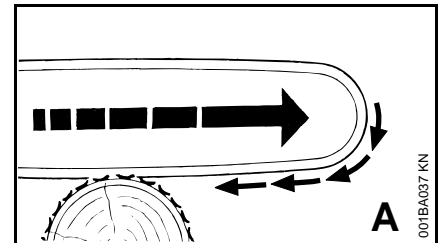

Pull-in occurs when the chain on the bottom of the bar is suddenly pinched, caught or encounters a foreign object in the wood. The reaction of the chain pulls the saw forward – **always hold the spiked bumper securely against the tree or limb.**

Pushback (B)

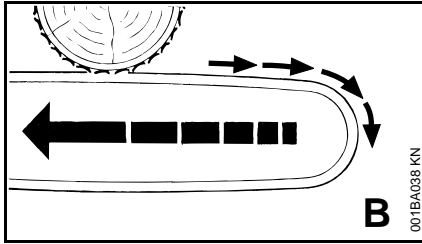

Pushback occurs when the chain on the top of the bar is suddenly pinched, caught or encounters a foreign object in the wood. The reaction of the chain drives the saw straight back toward the operator. **To avoid pushback.**

- Be alert to situations that may cause the top of the guide bar to be pinched
- Do not twist the guide bar in the cut.

Exercise extreme caution

- with leaners
- with trees that have fallen unfavorably between other trees and are under strain
- when working in blowdown areas.

Do not work with the chainsaw in such circumstances. Use block and tackle, cable winch or tractor.

Pull out exposed and cleared logs. Select clear area for cutting.

Deadwood (dry, decayed or rotted wood) represents a considerable risk that is difficult to assess. Identifying the extent of the dangers is complicated, if not impossible. Use aids such as a cable winch or tractor in such cases.

When felling in the vicinity of roads, railways, power lines, etc., take extra precautions. If necessary, inform the police, utility company or railway authority.

Cutting

Do not operate your saw with the starting throttle lock engaged. Engine speed cannot be controlled with the throttle trigger in this position.

Work calmly and carefully – in daylight conditions and only when visibility is good. Ensure you do not endanger others – stay alert at all times.

Use the shortest possible guide bar: The chain, guide bar and chain sprocket must match each other and your saw.

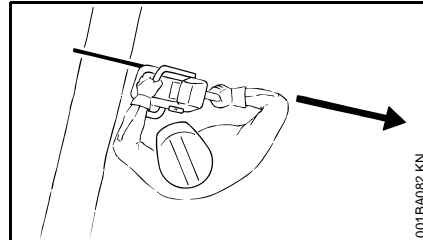

Position the saw so that your body is clear of the cutting attachment.

Always pull the saw out of the cut with the chain running.

Use your chain saw for cutting only. It is not designed for prying or shoveling away limbs, roots or other objects.

Do not underbuck freely hanging limbs.

To reduce the risk of injury, take special care when cutting shattered wood because of the risk of injury from splinters being caught and thrown in your direction.

Make sure your saw does not touch any foreign materials: Stones, nails, etc. may be flung off, damage the saw chain or cause the saw to kick back unexpectedly.

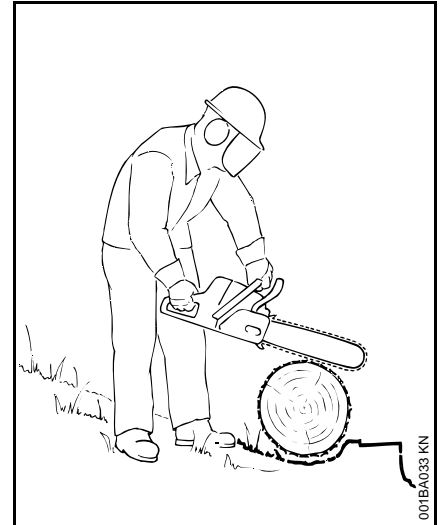

If on a slope, stand on the uphill side of the log. Watch out for rolling logs.

When working at heights:

- Always use a lift bucket
- Never work on a ladder or in a tree
- Never work on an insecure support
- Do not work above shoulder height
- Never operate your unit with one hand

Begin cutting with the saw at full throttle and engage the spiked bumper firmly in the wood, and then continue cutting.

Never work without the spiked bumper because the saw may pull you forwards and off balance. Always hold the spiked bumper securely against the tree or limb.

Note when reaching the end of a cut that the saw is no longer supported in the kerf. You have to take the full weight of the saw since **it might otherwise go out of control.**

Felling

Do not attempt felling unless you have been trained in the necessary techniques. **To reduce the risk of accidents and injury**, do not attempt felling or limbing if you are not an experienced chain saw user.

Observe all country-specific regulations on felling techniques.

Check that there are no other persons in the felling area – other than helpers.

Make sure no-one is endangered by the falling tree – the noise of your engine may drown any warning calls.

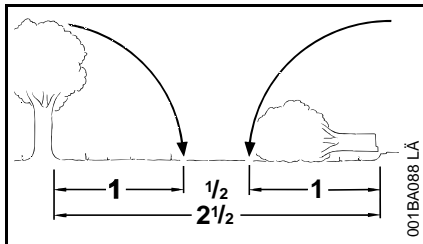

Maintain a distance of at least 2 1/2 tree lengths from the next felling site.

Determine direction of fall and escape paths

Select gap in stand into which you want the tree to fall.

Pay special attention to the following points:

- The natural lean of the tree
- Any unusually heavy limb structure, damage
- The wind direction and speed – do not fell in high winds
- Sloping ground
- Neighboring trees
- Snow load
- Soundness of tree – take special care if trunk is damaged or in case of deadwood (dry, decayed or rotted wood)

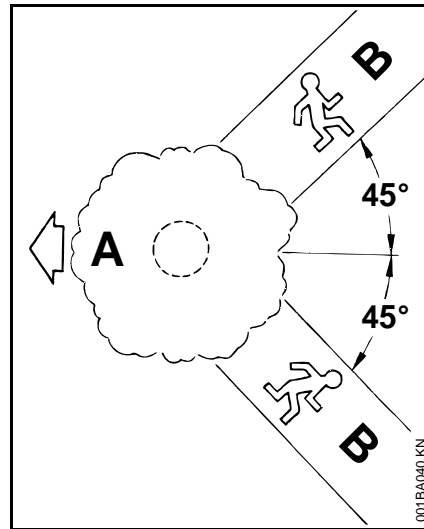

A Direction of fall

B Escape paths

- Establish paths of escape for everyone concerned – opposite to direction of fall at about 45°.
- Remove all obstacles from escape paths.
- Place all tools and equipment a safe distance away from the tree, but not on the escape paths.
- Always keep to the side of the falling tree and only walk away along the preplanned escape path.
- On steep slopes, plan escape routes parallel to the slope.
- When walking away along the escape path, watch out for falling limbs and watch the top of the tree.

Preparing work area at base of tree

- First clear the tree base and work area from interfering limbs and brush to provide a secure footing.
- Clean lower portion of tree base (e.g. with an axe) – sand, stones and other foreign objects will dull the saw chain.

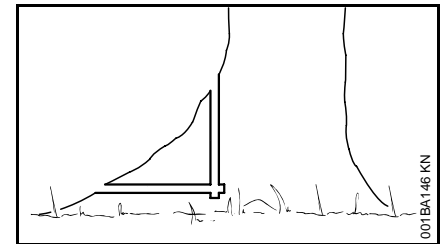

- Remove large buttress roots: Make the vertical cut first, then the horizontal – but only if the wood is sound

Felling notch

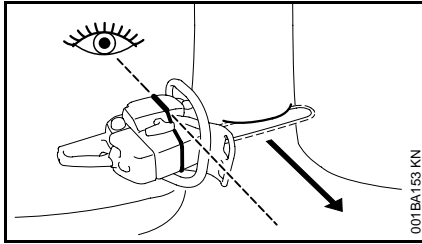

When making the felling notch, make use of the gunning sight on the shroud and fan housing to check the planned direction of fall.

Position your saw so that the gunning sight points in exactly the direction you want the tree to fall.

There are several approved methods for making the felling notch – observe country-specific regulations on felling techniques.

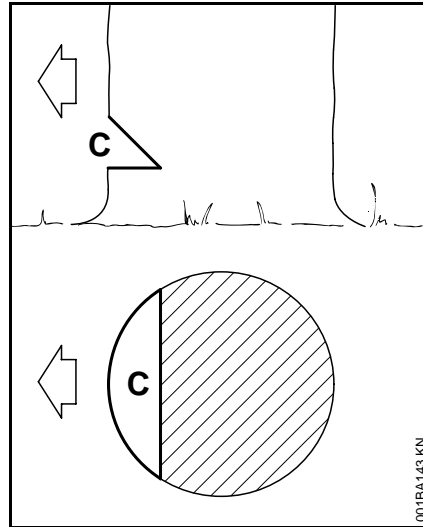

The felling notch (C) determines the direction of fall.

STIHL recommends the following method:

- Make the horizontal cut – check the direction of fall with the gunning sight.
- Make angle cut at about 45°.
- Check the felling notch and correct it if necessary.

Important:

- Felling notch at a right angle to the planned direction of fall.
- As close to the ground as possible.
- Cut to a depth of about 1/5 to 1/3 of the trunk diameter.

Sapwood cuts

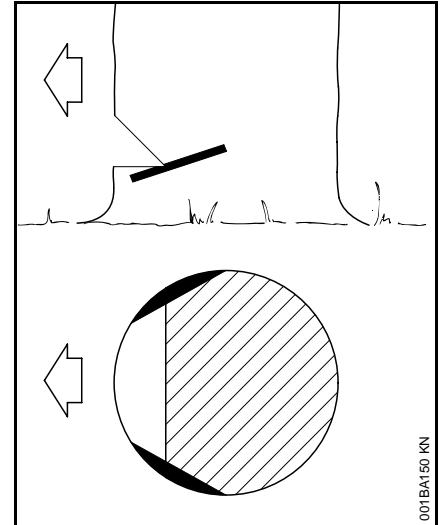

Sapwood cuts in long-fibered softwood help prevent sapwood splintering when the tree falls. Make cuts at both sides of the trunk at same height as bottom of felling notch to a depth of about 1/10 of trunk diameter. On large diameter trees, cut to no more than width of guide bar.

Do not make sapwood cuts if wood is diseased.

Felling

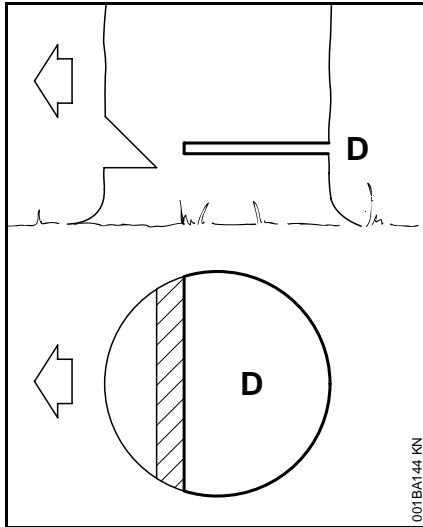

Shout a warning before starting the felling cut.

- Make the felling cut (D) slightly higher than bottom of the felling notch.
- Cut horizontally.
- Leave approx. 1/10 of the tree diameter uncut between the felling cut and the felling notch. This is the hinge.

Drive wedges into the felling cut in good time. Use only wooden, aluminum or plastic wedges. Never steel, which can damage the chain and cause kickback.

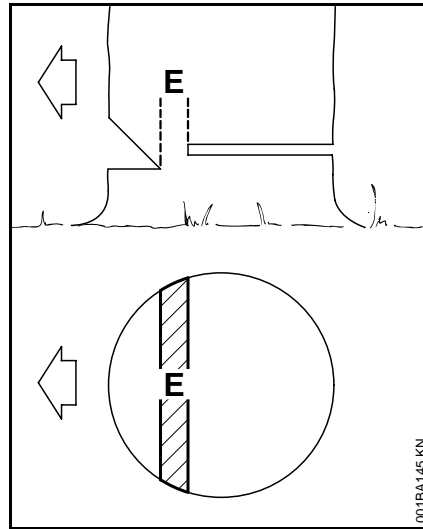

The **hinge (E)** helps control the falling tree.

- Do not cut through the hinge – you could lose control of the direction of fall – **this could result in an accident.**
- Leave a broader hinge on rotten trees.

Shout a second warning immediately before the tree falls.

Small diameter trees: Simple fan cut

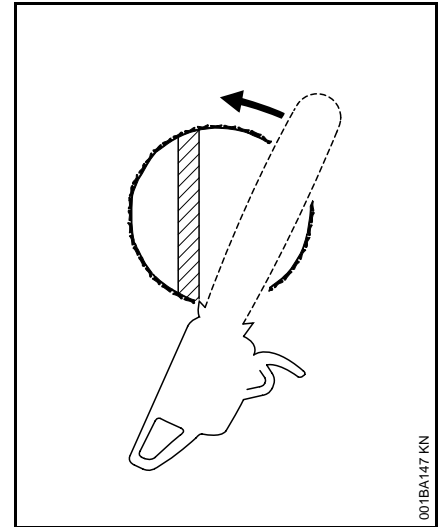

- Apply the spiked bumper behind the hinge – pivot the saw around this point – only as far as the hinge. The spiked bumper rolls against the trunk.

Large diameter trees: Sectioning method

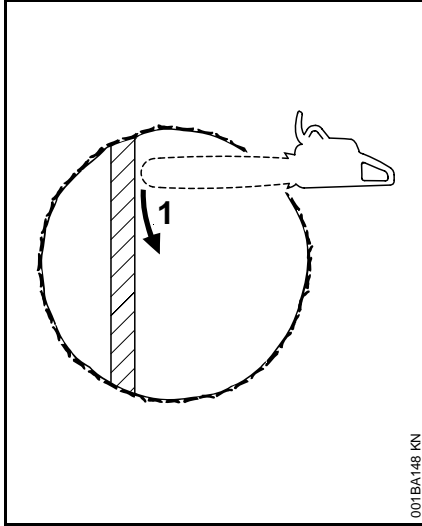

If the diameter of the tree is greater than the length of the guide bar, use the sectioning method.

1. First cut

Nose of guide bar should enter wood just behind the hinge – hold the saw horizontally and swing it as far as possible, using the bumper spike as a pivot – avoid repositioning the saw more than necessary.

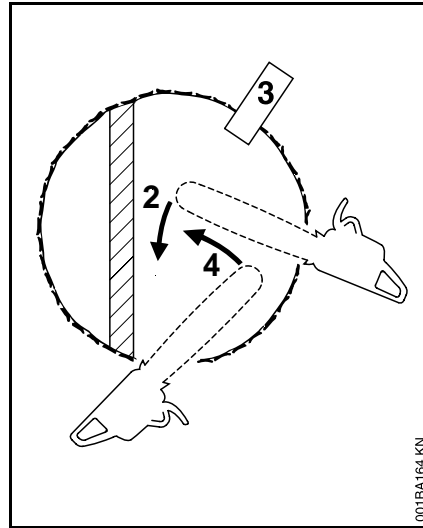

2. When repositioning the saw for the next cut, keep the guide bar fully engaged in the kerf to keep the felling cut straight – apply the spiked bumper again, and so on.
3. Insert a wedge (3) in the cut.
4. Last cut: Apply the spiked bumper as for the simple fan cut – do not cut through the hinge.

Special cutting techniques

Plunge cuts and heartwood cuts require special training and experience.

Plunge cutting

- For felling leaners
- For relieving cuts during bucking
- For DIY projects

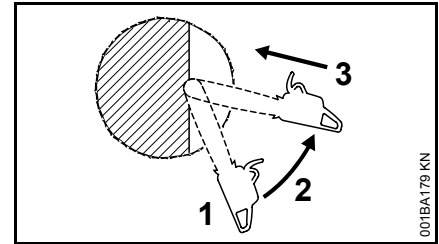

- Use a low kickback chain and exercise particular caution
1. Begin cut by applying the lower portion of the guide bar nose – do not use upper portion because of – **risk of kickback**. Cut until depth of kerf is twice the width of the guide bar.
 2. Swing saw slowly into plunge-cutting position – take care because of the **risk of kickback or pushback**.
 3. Make the plunge cut very carefully. **Danger of pushback**.

Heartwood cut

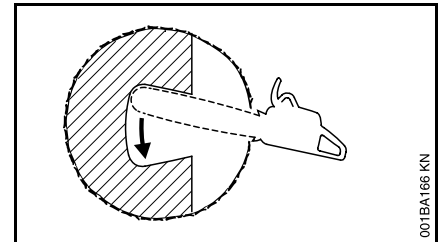

- If tree diameter is more than twice the length of the guide bar.
- If a large portion of heartwood remains uncut on large diameter trees.

- On trees that are difficult to fell (oak, beech), to prevent heartwood splintering and maintain planned direction of fall.
- On soft deciduous trees to relieve tension in lying log and prevent slivers in the center of the hinge being torn out of the log.
- Make the plunge cut in the center of the felling notch – **there is a danger of pushback at this point** – then swing the bar in the direction of the arrow.

Limbing

Do not attempt limbing unless you have been trained in the necessary techniques. **To reduce the risk of accidents and injury**, do not attempt felling or limbing if you are not an experienced chain saw user.

- Use a low kickback chain.
- Work with the saw supported wherever possible.
- Do not stand on the log while limbing it.
- Do not cut with the bar nose.
- Watch for limbs which are under tension.
- Never cut several limbs at once.

When cutting small logs

- Use a sturdy and stable support – sawhorse.
- Never hold the log with your leg or foot.
- Never allow another person to hold the log or help in any other way.

Lying or standing logs under tension

Always make cuts in the correct sequence (first at the compression side (1), then at the tension side (2), the saw may otherwise pinch or kick back – **risk of injury**).

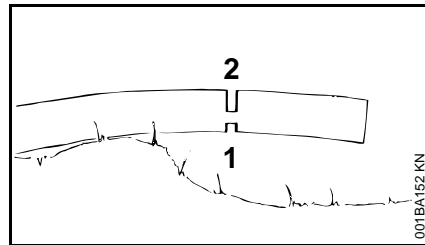
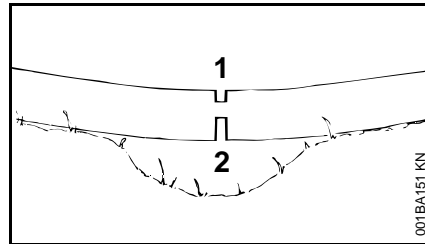

- Make relieving cut at the compression side (1)
- Make bucking cut at the tension side (2)

Be wary of **pushback** when making bucking cut from the bottom upwards (underbuck).

- ⚙ Do not cut a lying log at a point where it is touching the ground because the saw chain will otherwise be damaged.

Ripping cut

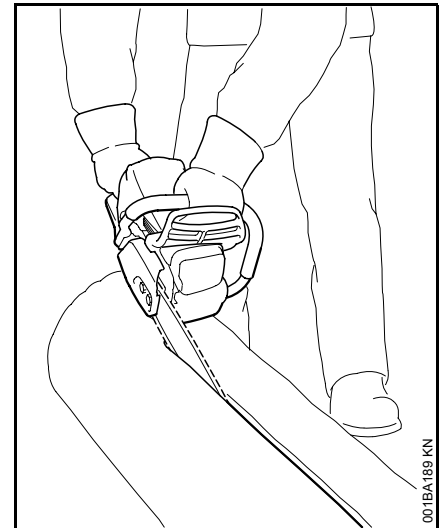

Cutting technique in which the bumper spike is not used – risk of pull-in – start the cut with the guide bar at the shallowest possible angle – take extra care since there is an increased **danger of kickback**.

Vibrations

Prolonged use of the power tool may result in vibration-induced circulation problems in the hands (whitefinger disease).

No general recommendation can be given for the length of usage because it depends on several factors.

The period of usage is prolonged by:

- Hand protection (wearing warm gloves)
- Work breaks

The period of usage is shortened by:

- Any personal tendency to suffer from poor circulation (symptoms: frequently cold fingers, tingling sensations).
- Low outside temperatures.
- The force with which the handles are held (a tight grip restricts circulation).

Continual and regular users should monitor closely the condition of their hands and fingers. If any of the above symptoms appear (e.g. tingling sensation in fingers), seek medical advice.

Maintenance and Repairs

Service the machine regularly. Do not attempt any maintenance or repair work not described in the instruction manual. Have all other work performed by a servicing dealer.

STIHL recommends that you have servicing and repair work carried out exclusively by an authorized STIHL servicing dealer. STIHL dealers are regularly given the opportunity to attend training courses and are supplied with the necessary technical information.

Only use high-quality replacement parts in order to avoid the risk of accidents and damage to the machine. If you have any questions in this respect, consult a servicing dealer.

STIHL recommends the use of genuine STIHL replacement parts. They are specifically designed to match your model and meet your performance requirements.

To reduce the risk of injury, **always shut off the engine** before carrying out any maintenance or repairs or cleaning the machine. – Exception: Carburetor and idle speed adjustments.

Do not turn the engine over on the starter with the spark plug boot or spark plug removed unless the slide control / stop switch is on **STOP** or **0** since there is otherwise a **risk of fire** from uncontained sparking.

To reduce the **risk of fire**, do not service or store your machine near open flames.

Check the fuel filler cap for leaks at regular intervals.

Use only a spark plug of the type approved by STIHL and make sure it is in good condition – see "Specifications".

Inspect the ignition lead (insulation in good condition, secure connection).

Check the condition of the muffler.

To reduce the **risk of fire and damage to hearing**, do not operate your machine if the muffler is damaged or missing. –

Do not touch a hot muffler since **burn injury** will result.

Vibration behavior is influenced by the condition of the AV elements – check the AV elements at regular intervals.

Check the chain catcher and replace it if damaged.

Stopping the Engine

- before checking chain tension.
- before retensioning the chain.
- before replacing the chain.
- before rectifying problems.

Observe sharpening instructions – keep the chain and guide bar in good condition at all times for safe and correct handling of the saw. The chain must be properly sharpened, tensioned and well lubricated.

Always change the chain, guide bar and sprocket in good time.

Check condition of clutch drum periodically.

Store fuel and chain lubricant in properly labelled, safety-type canisters only. When handling gasoline, avoid direct contact with the skin and avoid inhaling fuel vapour – **health risk**.

To reduce the risk of injury, shut off the engine immediately if the chain brake malfunctions – contact your servicing dealer – do not use your power tool until the problem has been rectified (see "Chain Brake").

Cutting Attachment

STIHL is the only manufacturer in the industry to produce its own chain saws, guide bars, saw chains and chain sprockets.

A cutting attachment consists of the saw chain, guide bar and chain sprocket.

The cutting attachment that comes standard is designed to exactly match the chain saw.

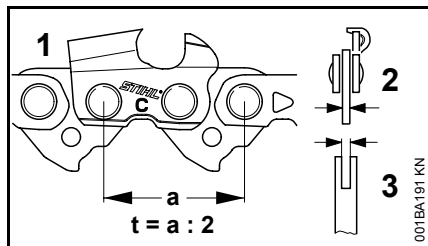

- The pitch (t) of the saw chain (1), chain sprocket and the nose sprocket of the Rollomatic guide bar must match.
- The drive link gauge (2) of the saw chain (1) must match the groove width of the guide bar (3).

If non-matching components are used, the cutting attachment may be damaged beyond repair after a short period of operation.

Mounting the Bar and Chain

Removing the chain sprocket cover

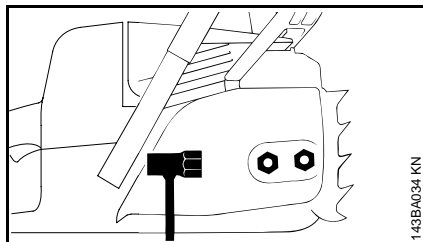

- Unscrew the nuts and take off the chain sprocket cover.

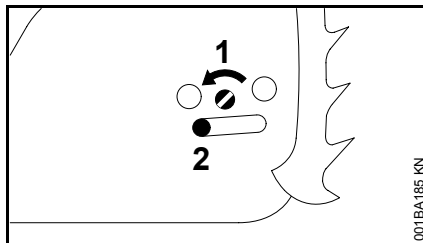

- Turn the screw (1) counterclockwise until the tensioner slide (2) butts against the left end of the housing slot.

Disengaging the chain brake.

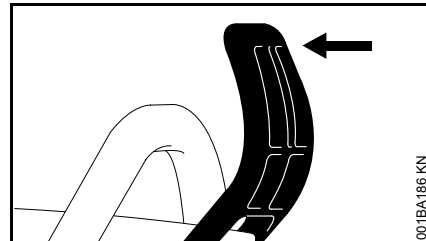

- Pull the hand guard towards the front handle until there is an audible click – the chain brake is disengaged.

Fitting the chain

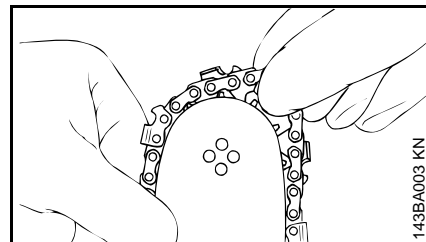

! Wear work gloves to protect your hands from the sharp cutters.

- Fit the chain – start at the bar nose.

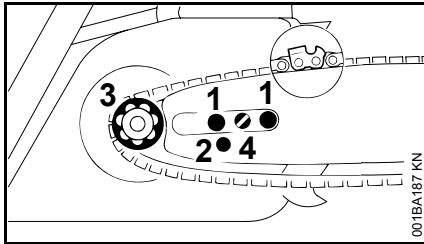

- Fit the guide bar over the studs (1) – the cutting edges on the top of the bar must point to the right.
- Engage the peg of the tensioner slide in the locating hole (2) – place the chain over sprocket (3) at the same time.
- Turn the tensioning screw (4) clockwise until there is very little chain sag on the underside of the bar – and the drive link tangs are engaged in the bar groove.
- Refit the sprocket cover and screw on the nuts only fingertight.
- Go to chapter on "Tensioning the Saw Chain"

Tensioning the Chain

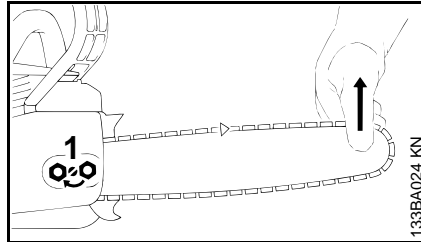

Retensioning during cutting work:

- Shut off the engine.
- Loosen the nuts.
- Hold the bar nose up.
- Use a screwdriver to turn the tensioning screw (1) clockwise until the chain fits snugly against the underside of the bar.
- While still holding the bar nose up, tighten down the nuts firmly.
- Go to "Checking Chain Tension".

A new chain has to be retensioned more often than one that has been in use for some time.

- Check chain tension frequently – see chapter on "Operating Instructions".

Checking Chain Tension

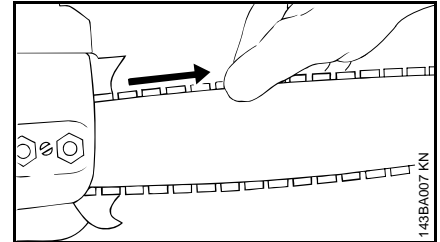

- Shut off the engine.
- Wear work gloves to protect your hands.
- The chain must fit snugly against the underside of the bar and it must still be possible to pull the chain along the bar by hand.
- If necessary, retension the chain.

A new chain has to be retensioned more often than one that has been in use for some time.

- Check chain tension frequently – see chapter on "Operating Instructions".

Fuel

Your engine requires a mixture of gasoline and engine oil.

 For health reasons, avoid direct skin contact with gasoline and avoid inhaling gasoline vapor.

STIHL MotoMix

STIHL recommends the use of STIHL MotoMix. This ready-to-use fuel mix contains no benzol or lead, has a high octane rating and ensures that you always use the right mix ratio.

STIHL MotoMix is specially formulated for use in STIHL engines and guarantees a long engine life.

MotoMix is not available in all markets.

Mixing Fuel

 Unsuitable fuels or lubricants or mix ratios other than those specified may result in serious damage to the engine. Poor quality gasoline or engine oil may damage the engine, sealing rings, hoses and the fuel tank.

Gasoline

Use only high-quality brand-name gasoline with a minimum octane rating of 90 – leaded or unleaded.

If your machine is equipped with a catalytic converter, you must use unleaded gasoline.

 A few tankfuls of leaded gasoline will greatly reduce the efficiency of the catalytic converter.

Engine Oil

Use only quality two-stroke engine oil. We recommend **STIHL two-stroke engine oil since it is specially formulated for use in STIHL engines and guarantees a long engine life.**

If STIHL two-stroke engine oil is not available, use only quality two-stroke oil designed for use in air-cooled engines. Do not use oils designed for water-cooled engines or engines with a separate lubricating system (e.g. conventional four-stroke engines).

Use only **STIHL 50:1 two-stroke engine oil** for the fuel mix in models with a catalytic converter.

Mix Ratio

STIHL 50:1 two-stroke engine oil: 50 parts gasoline to 1 part oil

Examples

Gasoline Liters	STIHL engine oil 50:1 Liters (ml)
1	0,02 (20)
5	0,10 (100)
10	0,20 (200)
15	0,30 (300)
20	0,40 (400)
25	0,50 (500)

 Other brand-name two-stroke engine oils: 25 parts gasoline to 1 part oil

- Use a canister approved for storing fuel. Pour oil into canister first, then add gasoline and mix thoroughly.

Storing Fuel

Store fuel only in approved safety-type fuel canisters in a dry, cool and safe location protected from light and the sun.

Fuel mix ages – only mix sufficient fuel for a few weeks work. Do not store fuel mix for longer than 3 months. Exposure to light, the sun, low or high temperatures can quickly make the fuel mix unusable.

- Thoroughly shake the mixture in the canister before fueling your machine.

 Pressure may build up in the canister – open it carefully.

- Clean the fuel tank and canister from time to time.

Dispose of remaining fuel and cleaning fluid properly in accordance with local regulations and environmental requirements.

Fueling



Fuel filler cap

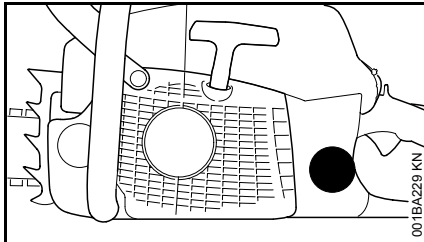

- Before fueling, clean the cap and the area around it to ensure that no dirt falls into the fuel tank
- Always position the machine so that the cap is facing upwards

Opening

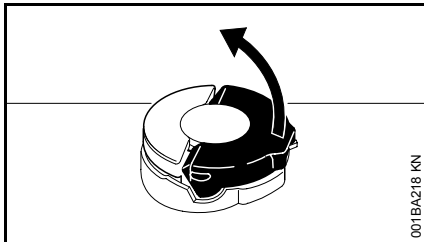

- Swing the clip into an upright position

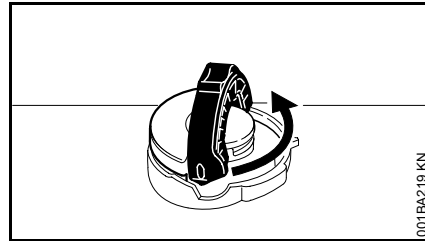

- Turn the cap counterclockwise (approx. 1/4 turn)

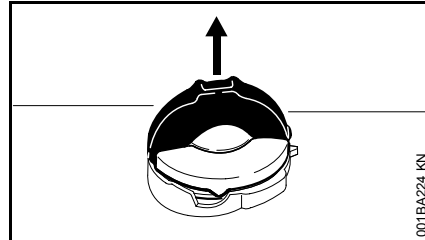

- Remove fuel filler cap

Refueling

Take care not to spill fuel while fueling and do not overfill the tank.

STIHL recommends use of the STIHL filling system for fuel (special accessory).

- Refueling

Closing

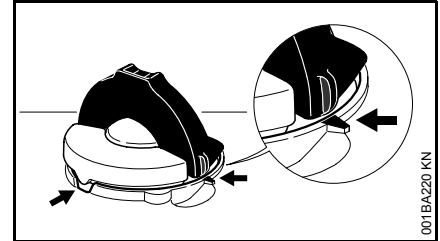

Clip is in an upright position:

- Fit the cap – position marks on the cap and the filling port must line up
- Push the cap down as far as it will go

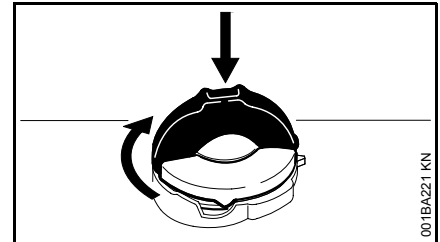

- Hold the cap down and twist it clockwise until it engages

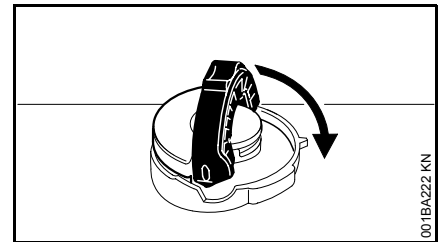

- Fold down the clip as far as it will go

Checking the lock

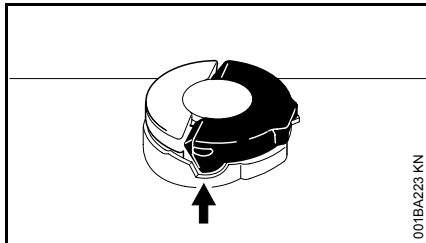

- The lug on the clip must engage entirely in the recess (arrow)

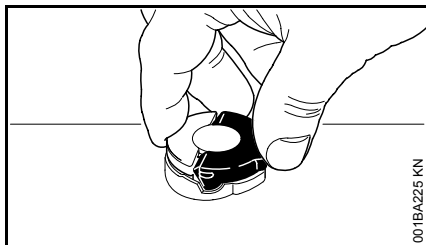

- Grip the cap – if the cap cannot be moved or removed, then it is closed properly

If the cap can be moved or removed

The base of the cap is tilted in relation to the upper part:

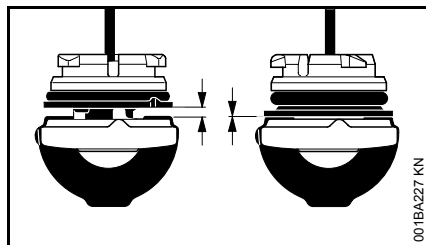

- Left: Base of cap tilted
 Right: Base of cap correctly positioned

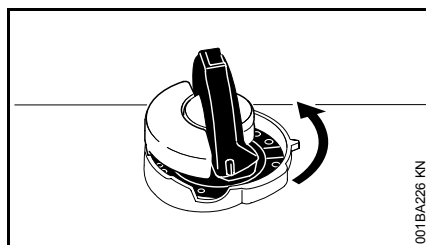

- Fit cap and twist it counterclockwise until it engages in the seat of the filling port
- Continue to twist the cap counterclockwise (approx. 1/4 turn) – this will twist the base of the cap into the correct position
- Twist the cap clockwise and close it – see the section "Closing" and "Checking the lock"

Chain Lubricant

For automatic and reliable lubrication of the chain and guide bar – use only an environmentally compatible quality chain and bar lubricant. Rapidly biodegradable STIHL Bioplus is recommended.

- ⚙ Biological chain oil must be resistant to aging (e.g. STIHL Bioplus) since it will otherwise quickly turn to resin. This results in hard deposits that are difficult to remove, especially in the area of the chain drive, clutch and chain. It may even cause the oil pump to seize.

The service life of the chain and guide bar depends on the quality of the lubricant. It is therefore essential to use only a specially formulated chain lubricant.

- ⚠ **Do not use waste oil.** Renewed contact with waste oil can cause skin cancer. Moreover, waste oil is environmentally harmful.

- ⚙ Waste oil does not have the necessary lubricating properties and is unsuitable for chain lubrication.

Filling Chain Oil Tank



Preparations

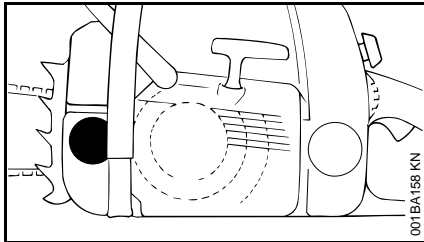

- Thoroughly clean the oil filler cap and the area around it to ensure that no dirt falls into the tank.
- Position the machine so that the filler cap is facing up.
- Open the filler cap.

Fill up with chain oil.

- Refill the chain oil tank every time you refuel.

Take care not to spill chain oil while refilling and do not overfill the tank.

STIHL recommends you use the STIHL filler nozzle for chain oil (special accessory).

- Close the filler cap.

There must still be a small amount of oil in the oil tank when the fuel tank is empty.

If the oil level in the tank does not go down, the reason may be a fault in the oil supply system: Check chain lubrication, clean the oilways, contact your dealer for assistance if necessary. STIHL recommends that you have servicing and repair work carried out exclusively by an authorized STIHL servicing dealer.

Checking Chain Lubrication

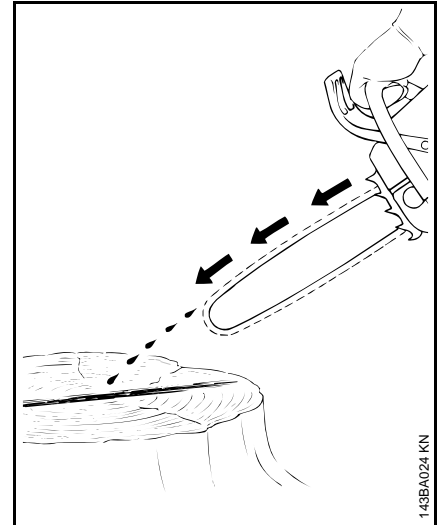

The saw chain must always throw off a small amount of oil.

 Never operate your saw without chain lubrication. If the chain runs dry, the whole cutting attachment will be irretrievably damaged within a very short time. Always check chain lubrication and the oil level in the tank before starting work.

Every new chain has to be broken in for about 2 to 3 minutes.

After breaking in the chain, check chain tension and adjust if necessary – see "Checking Chain Tension".

Chain Brake



Locking the chain

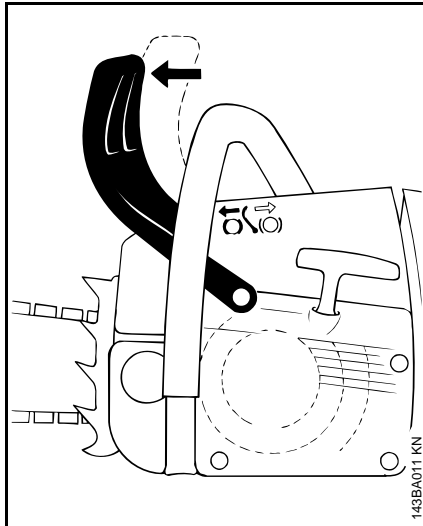

- in an emergency
- when starting
- at idling speed

The chain brake is activated by pushing the hand guard toward the bar nose with your left hand – or by inertia in certain kickback situations: The chain is stopped and locked.

Releasing the chain brake

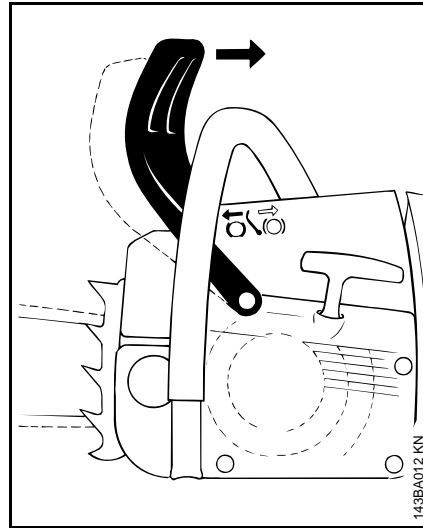

- Pull the hand guard back toward the front handle,



Always disengage chain brake before accelerating the engine (except when checking its operation) and before starting cutting work.

High revs with the chain brake engaged (chain locked) will quickly damage the powerhead and chain drive (clutch, chain brake).

The chain brake is also activated by the inertia of the front hand guard if the kickback force of the saw is high enough: The hand guard is accelerated toward the bar nose – even if your left hand is not behind the hand guard, e.g. during felling cut.

The chain brake will operate only if the hand guard has not been modified in any way.

Check operation of the chain brake

Before starting work: Run engine at idle speed, engage the chain brake (push hand guard toward bar nose) and open the throttle wide for no more than 3 seconds – the chain must not rotate. The hand guard must be free from dirt and move freely.

Chain brake maintenance

The chain brake is subject to normal wear. It is necessary to have it serviced and maintained regularly by trained personnel. STIHL recommends that you have servicing and repair work carried out exclusively by an authorized STIHL servicing dealer. Maintain the following servicing intervals:

Full-time usage:	every 3 months
Part-time usage:	every 6 months
Occasional usage:	every 12 months

Winter Operation



Remove shroud

- Move the Master Control lever to the stop position 0
- Push the hand guard forwards – the saw chain is blocked

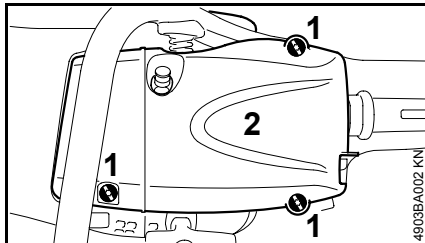

- Loosen screws (1)
- Remove the shroud (2)

Pre-heat carburetor

At temperatures below +10 °C

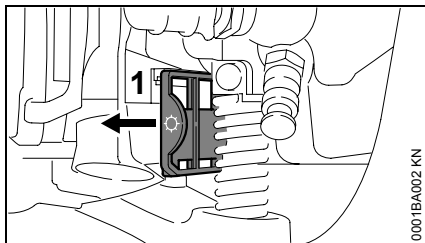

- Pull the slide (1) out of the position ☀ (summer operation)

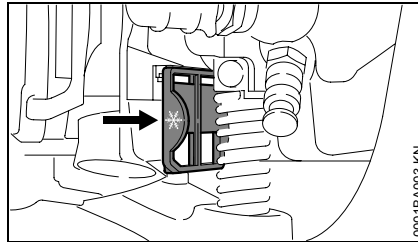

- Place the slide in the position ❄ (winter operation) – ❄ facing upwards
- Refit the shroud and tighten the screws

Heated air is now drawn in from around the cylinder and circulates around the carburetor – this helps prevent carburetor icing.

At temperatures above +20 °C

- Ensure that the slide is set back to position ☀ (summer operation) without fail, otherwise the engine may malfunction due to overheating

At temperatures below -10 °C

Under extreme winter conditions (temperatures below -10 °C, powdered or drifting snow), it is recommended to use the "cover plate mounting kit" (special accessory).

In case of erratic idling behavior or poor acceleration

- Turn the low speed screw (L) 1/4 turn counterclockwise

Whenever the low speed screw (L) has been adjusted, it is usually also necessary to adjust the idle speed adjusting screw (LA), see "Setting the carburetor".

- if the chain saw is extremely cold (frost formation) – after starting, bring the engine up to operating temperature at increased idle speed (disengage chain brake!)

Cover plate

The cover plate (special accessory) keeps out powdered or drifting snow.

When the cover plate is used, the slide must be in the winter position.

If engine trouble occurs, first check whether use of the cover plate is necessary.

Attach cover plate

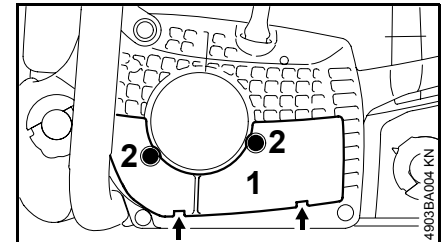

- Insert cover plate (1) with both tabs (arrows) and fasten with the screws (2)

Starting / Stopping the Engine

Positions of the Master Control lever

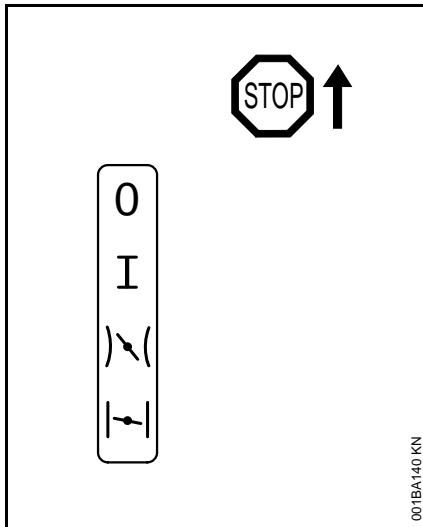

Stop 0 – engine off – ignition is switched off

Operating position I – engine is running or can start

Warm start)\| – this position is for starting the warm engine – the Master Control lever returns to the operating position when the throttle trigger is squeezed

Cold start |-\| – this position is for starting the cold engine

Adjust Master Control lever

To adjust the Master Control lever from the operating position I to cold start |-\|, press and hold down the throttle trigger lockout and throttle trigger simultaneously – set Master Control lever.

To set the Master Control lever to warm start)\|, first set it to cold start |-\|, then push the Master Control lever into the warm start)\| position.

Switching to the warm start)\| position is only possible from the cold start |-\| position.

Simultaneously pressing the throttle trigger lockout and blipping the throttle trigger causes the Master Control lever to jump from the warm start)\| position to the operating position I.

To switch off the engine, set the Master Control lever to Stop 0.

Position choke shutter closed |-\|

- if engine is cold
- if the engine stalls during opening of throttle after starting
- if the fuel tank has run empty (engine stalled out)

Position starting acceleration)\|

- if engine is warm (once the engine has been running for approx. one minute)
- when the engine has turned over for the first time
- after ventilation of the combustion chamber, if the engine was flooded

Holding the chain saw

There are two ways to hold the chain saw during starting.

On the ground

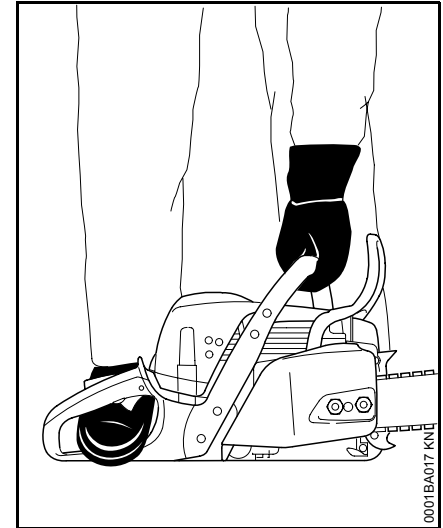

- Place the chain saw securely on the ground – assume a steady stance – the saw chain must not touch any objects and also must not touch the ground
- With the left hand on handlebar, press the chain saw firmly against the ground – thumb wrapped around the handlebar
- Place your right foot through the rear handle

Between the knees or thighs

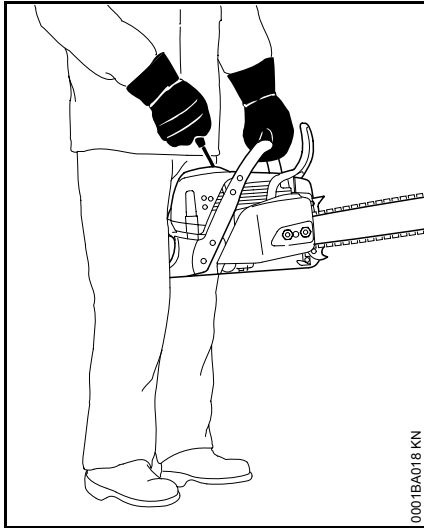

- clamp the rear handle between the knees or thighs
- grip the handlebar firmly with the left hand – thumb wrapped around the handlebar

Starting

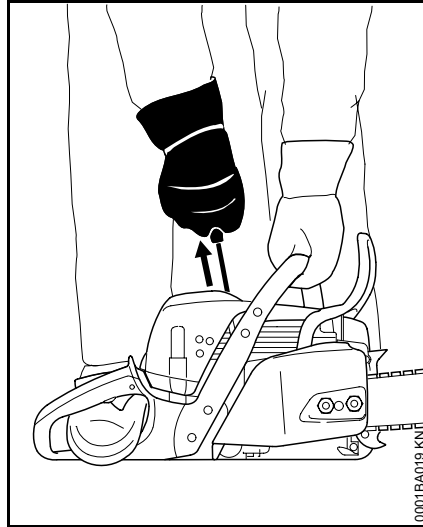

- with the right hand, pull the starter grip slowly until you feel it engage – and then give it a brisk strong pull – simultaneously press down on the handlebar – do not pull the starter rope out all the way – **risk of breakage!** Do not let the starter grip snap back – guide it slowly back into the housing so that it can rewind properly

With a new engine or after a long period of disuse, with machines without an additional manual fuel pump, it may be necessary to pull the starter rope several times - to prime the fuel line.

Starting the chain saw

 There must not be anyone within the swivel range of the chain saw.

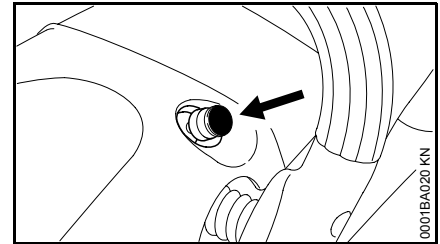

- Press the button, the decompression valve will be opened

The decompression valve is closed automatically when the engine starts for the first time. For this reason, press the button again before each additional starting procedure.

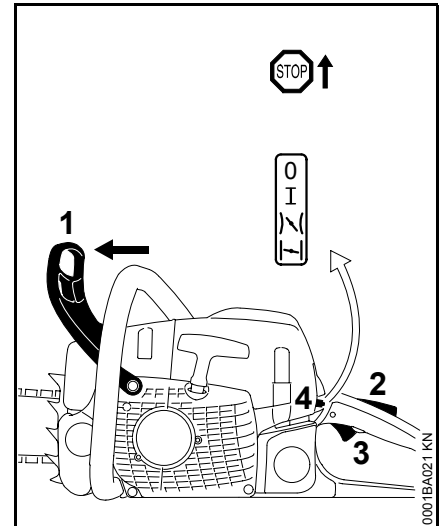

- Push the hand guard (1) forwards – the saw chain is blocked
- Simultaneously press the throttle trigger lockout (2) and throttle trigger (3) – set master control lever (4)

Position choke shutter closed I

- if engine is cold (even if the engine has stalled during opening of throttle after starting)

Position starting acceleration I

- if engine is warm (once the engine has been running for approx. one minute)
- Hold and start the chain saw

When the engine has turned over for the first time

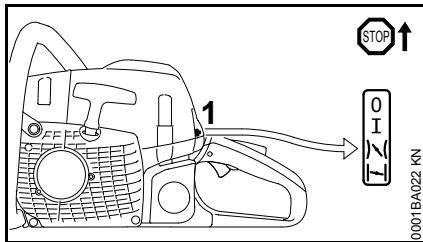

- Move the Master Control lever (1) to the position starting acceleration I
- Press the button on the decompression valve
- Hold and start the chain saw

Once the engine is running

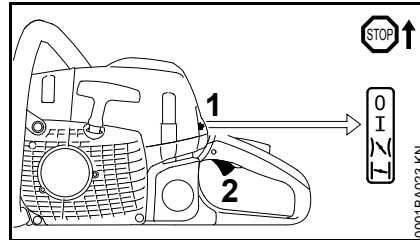

- Press the throttle trigger lockout and blip the throttle trigger (2); the Master Control lever (1) jumps to the operating position **I** and the engine begins to idle

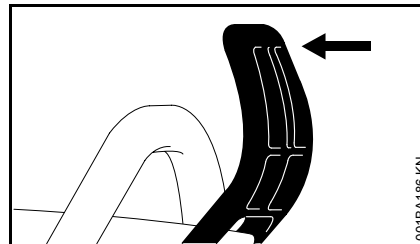

- Pull the hand guard toward the handlebar

The chain brake is released – the chain saw is ready for use.



Open the throttle only when the chain brake is off. Increased engine speeds with the chain brake on (saw chain is stationary) will quickly damage the clutch and chain brake.

At very low outside temperatures

- let the engine warm up briefly with the throttle slightly open
- if necessary, configure for winter operation, see "Winter Operation"

Switch off engine

- Move the Master Control lever to the stop position **0**

If the Master Control lever was moved from the position starting acceleration I to the stop position **0** – afterwards simultaneously press the throttle trigger lockout and the throttle trigger.

If the engine does not start

The Master Control lever was not returned from the position choke shutter closed I to starting acceleration I in time, the engine may be flooded.

- Move the Master Control lever to the stop position **0**
- Remove the spark plug – see "Spark plug"
- Dry spark plug
- Crank the engine several times with the starter – to clear the combustion chamber
- Replace the spark plug – see "Spark plug"
- Set the Master Control lever to starting acceleration I – even if the engine is cold

- Press the button on the decompression valve
- Restart the engine

Operating Instructions

During the break-in period

A factory new machine should not be run at high revs (full throttle off load) for the first three tank fillings. This avoids unnecessarily high loads during the break-in period. As all moving parts have to bed in during the break-in period, the frictional resistances in the shortblock are greater during this period. The engine develops its maximum power after about 5 to 15 tank fillings.

During work

 Do not make the mixture leaner to achieve an apparent increase in power – this could damage the engine – see "Adjusting the Carburetor".

 Open the throttle only when the chain brake is off. Running the engine at high revs with the chain brake engaged (chain locked) will quickly damage the shortblock and chain drive (clutch, chain brake).

Check chain tension frequently

A new saw chain must be retensioned more frequently than one that has been in use already for an extended period.

Chain cold

Tension is correct when the chain fits snugly against the underside of the bar but can still be pulled along the bar by hand. Retension if necessary – see "Tensioning the Saw Chain".

Chain at operating temperature

The chain stretches and begins to sag. The drive links must not come out of the bar groove on the underside of the bar – the chain may otherwise jump off the bar. Retension the chain – see "Tensioning the Saw Chain".

 The chain contracts as it cools down. If it is not slackened off, it can damage the crankshaft and bearings.

After a long period of full-throttle operation

After a long period of full-throttle operation, allow engine to run for a while at idle speed so that the heat in the engine can be dissipated by flow of cooling air. This protects engine-mounted components (ignition, carburetor) from thermal overload.

After finishing work

- Slacken off the chain if you have retensioned it at operating temperature during work.

 Always slacken off the chain again after finishing work. The chain contracts as it cools down. If it is not slackened off, it can damage the crankshaft and bearings.

Short-term storage

Wait for engine to cool down. Keep the machine with a full tank of fuel in a dry place, well away from sources of ignition, until you need it again.

Long-term storage

See "Storing the machine"

Oil Quantity Control

Adjustable flow oil pump is a special option.

Different quantities of oil are required for different bar lengths, types of wood and cutting techniques.

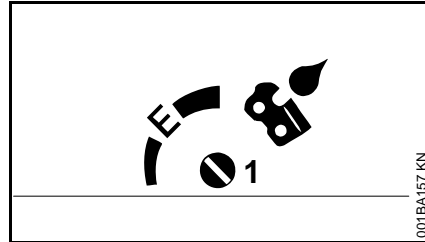

Use the adjusting screw (1) (on underside of machine) to vary the oil feed rate as required.

Ematic position (E), medium oil flow rate –

- turn the adjusting screw to "E" (Ematic position).

To increase oil feed –

- turn the adjusting screw clockwise.

Turn reduce oil feed –

- turn the adjusting screw counterclockwise.



The chain must always be wetted with a film of lubricant.

Taking Care of the Guide Bar

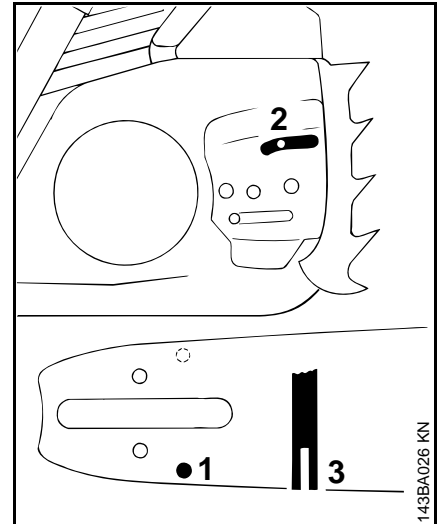

- Turn the bar over – every time you sharpen the chain and every time you replace the chain – this helps avoid one-sided wear, especially at the nose and underside of the bar.
- Regularly clean the oil inlet hole (1), the oilway (2) and the bar groove (3).
- Measure the groove depth – with the scale on the filing gauge (special accessory) – in the area used most for cutting.

Chain type	Pitch	Minimum groove depth
Picco	3/8" P	5.0 mm
Rapid	1/4"	4.0 mm
Rapid	3/8"; 0.325"	6.0 mm
Rapid	0.404"	7.0 mm

If groove depth is less than specified:

- Replace the guide bar.

The drive link tangs will otherwise scrape along the bottom of the groove – the cutters and tie straps will not ride on the bar rails.

Air Filter System

The air filter system can be adapted to different operating conditions by the insertion of different air filters. Retrofitting is simple.

Depending on equipment version, the machine is equipped with a fleece filter, a fleece filter with a felt prefilter or a fabric filter.

Fleece filter

For normal or dry applications.

Fleece filter with felt prefilter

For very dusty operating environments.

Fabric filter

For extreme winter conditions (e.g., powdered or drifting snow or frost formation).

Cleaning the Air Filter

If there is a noticeable loss of engine power

Remove shroud

- Move the Master Control Lever to the stop position **0**
- Push the front hand guard forwards – the saw chain is blocked

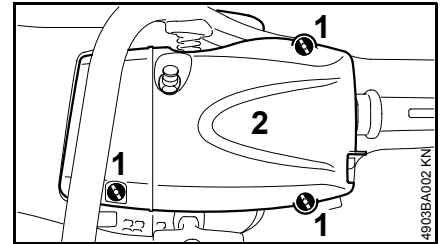

- Loosen screws (1)
- Remove the shroud (2)

Remove air filter

- Clean away loose dirt from around the filter



Do not use tools to remove and install the air filter – the air filter could be damaged in the process.

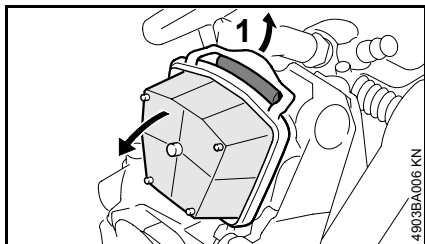

- Push the clip (1) up and to the rear and tilt the air filter toward the rear handle and remove it

- Always replace a damaged filter

For versions with "fleece filter with felt prefilter"

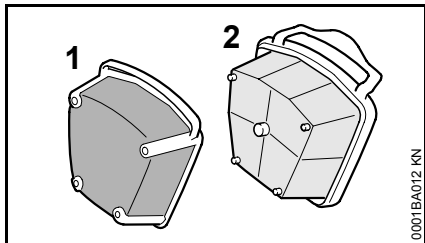

- Separate felt filter (1) from fleece filter (2) – clean, see "Cleaning the air filter"

Cleaning the air filter

- Knock out the filter or blow it clear with compressed air from the inside outwards

In case of stubborn dirt:

- Wash the filter in STIHL special-purpose cleaner (special accessories) or a clean, non-flammable cleaning liquid (e.g., warm soapy water) and dry it

 Do not clean fleece filters with a brush!

The felt prefilter protects the fleece filter and increases its service life. Thus it should be replaced at shorter intervals than the fleece filter.

Installing the air filter

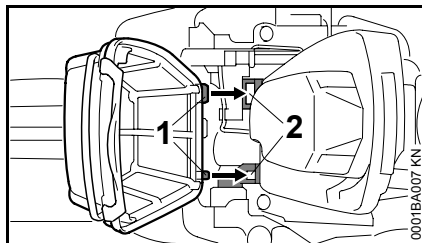

- Insert the lugs (1) into the recesses (2)
- Tilt the air filter toward the filter housing and close the clip
- Refit the shroud and tighten the screws

Adjusting the Carburetor

General Information

The carburetor comes from the factory with a standard setting.

This setting provides an optimum fuel-air mixture under most operating conditions.

With this carburetor it is only possible to correct the adjusting screws within fine limits.

 If the setting is too lean there is a risk of engine damage due to insufficient lubrication and overheating.

Standard setting

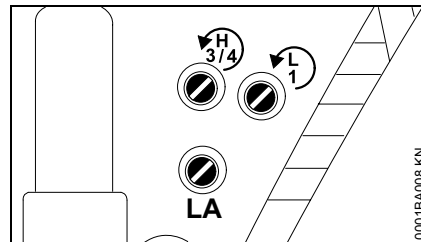

- Shut off the engine
- Check the air filter and clean or replace if necessary.
- Check the spark arresting screen (country-specific) in the muffler and clean or replace if necessary.

- Turn the high speed screw (H) counterclockwise as far as stop (no more than 3/4 turn).
- Turn the low speed screw (L) carefully clockwise as far as stop, then turn it back 1 full turn.

Adjusting idle speed

Engine stops while idling

- Open the low speed screw (L) one full turn.
- Turn the idle speed screw (LA) clockwise until the chain begins to run – then back it off 1 1/2 turns.

Chain runs when engine is idling

- Open the low speed screw (L) one full turn.
- Turn the idle speed screw (LA) counterclockwise until the chain begins to run – then turn it another 1 1/2 turns in the same direction.

 If the chain continues moving when the engine is idling, have your saw checked and repaired by your servicing dealer.

Erratic idling behavior, poor acceleration (even though low speed screw is open one turn)

- Idle setting is too lean: Turn the low speed screw (L) counterclockwise until the engine runs and accelerates smoothly.

It is usually necessary to change the setting of the idle speed screw (LA) after every correction to the low speed screw (L).

Fine tuning for operation at high altitude

A slight correction of the setting may be necessary if the engine does not run satisfactorily:

- Turn high speed screw (H) clockwise (leaner) – no further than stop.



If the setting is too lean there is a risk of engine damage due to insufficient lubrication and overheating.

Spark Arresting Screen in Muffler

In some countries the muffler is equipped with a spark arresting screen.

- If the engine is down on power, check the spark arresting screen in the muffler.
- Wait for the muffler to cool down.

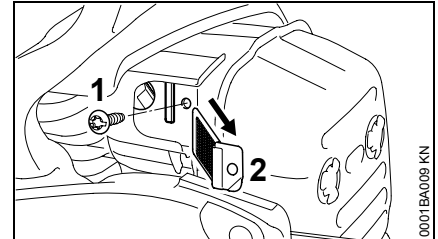

- Take out the screw (1).
- Pull out the spark arresting screen (2).
- Clean the spark arresting screen. If the screen is damaged or heavily carbonized, fit a new one.
- Refit the spark arresting screen.
- Insert the screw and tighten it down.

Spark Plug

- If the engine is down on power, difficult to start or runs poorly at idle speed, first check the spark plug.
- Fit a new spark plug after about 100 operating hours – or sooner if the electrodes are badly eroded. Install only suppressed spark plugs of the type approved by STIHL – see "Specifications".

Remove the spark plug

- Move the Master Control lever to the stop position **0**
- Push the hand guard forwards – the saw chain is blocked

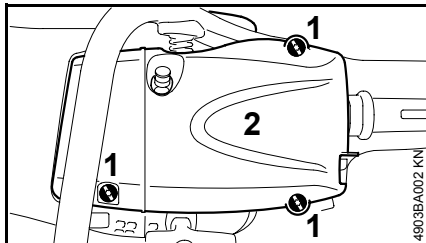

- Loosen screws (1)
- Remove the shroud (2)

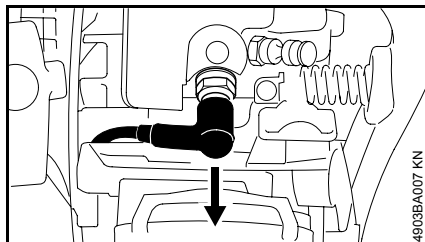

- Pull off the spark plug boot
- Unscrew spark plug

Checking the spark plug

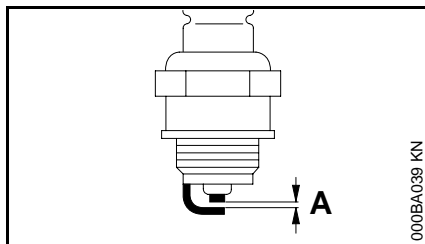

- Clean dirty spark plug.
- Check electrode gap (A) and readjust if necessary – see "Specifications".
- Rectify the problems which have caused fouling of the spark plug.

Possible causes are:

- Too much oil in fuel mix.
- Dirty air filter.
- Unfavorable running conditions.

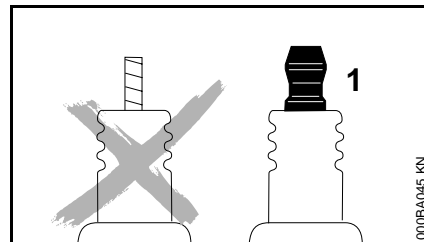

- !** If the spark plug comes with a detachable adapter nut (1), screw the adapter onto the thread and tighten it down **firmly** to reduce the risk of arcing and fire.

Install spark plug

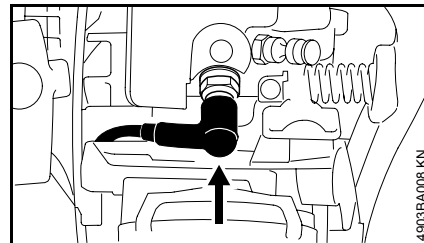

- Screw in the spark plug and press on the spark plug boot
- Refit the shroud and tighten the screws

Replacing the Starter Rope and Rewind Spring

Remove shroud

- Move the Master Control lever to the stop position 0
- Push the hand guard forwards – the saw chain is blocked

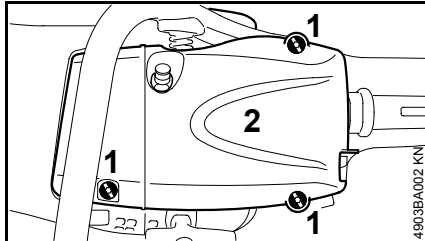

- Loosen screws (1)
- Remove the shroud (2)

Removing the fan housing

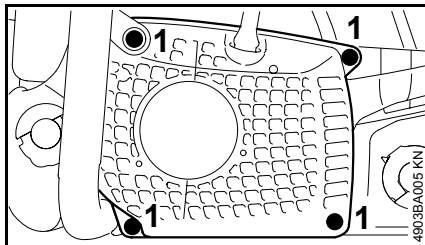

- Remove screws (1)
- Push hand guard upward
- Pull the bottom of the fan housing away from the crankcase and remove downwards

Replace torn starter rope

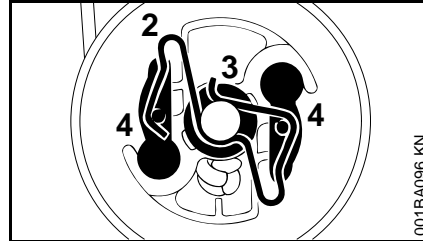

- Carefully press the spring clip (2) off of the axle with a screw driver or suitable pliers
- Carefully remove the rope rotor with washer (3) and pawls (4)

⚠ The rewind spring can jump out – risk of injury!

- Lever the rope out of the starter handle with a screwdriver
- Remove the remainder of the rope from the rotor and starter handle

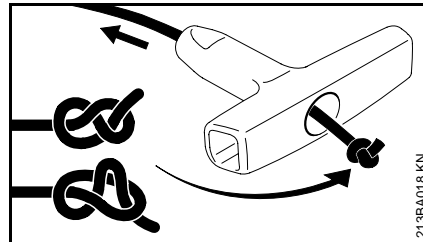

- Thread the new starter rope through the starter handle and secure it by making a special knot
- Pull the knot into the starter handle

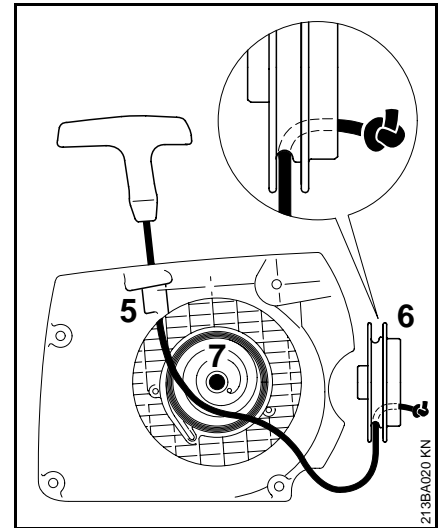

- Thread the rope from above through the rope guide bush (5) and rope rotor (6) and secure with a simple knot
- Coat the bearing bore in the rope rotor with non-resinous oil
- Slip the rope rotor onto the starter post (7) – turn it back and forth a little until the anchor loop of the rewind spring engages

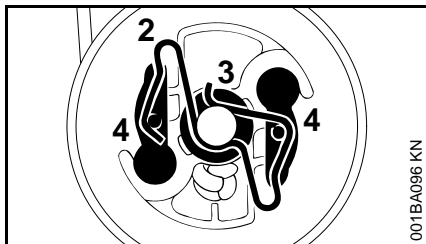

- Refit the pawls (4) in the rotor and slip the washer (3) over the starter post
- Press the spring clip (2) on to the starter post and over the pegs of the pawl with a screwdriver or suitable pliers – the spring clip must point in the clockwise direction – as in the picture

Tension the rewind spring

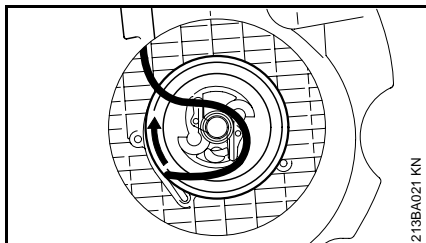

- Make a loop in the unwound starter rope and use it to turn the rope rotor six full revolutions in the direction of the arrow
- Hold the rope rotor tight – pull out the twisted rope and untangle it
- Release the rope rotor
- Slowly let go of rope so that it winds onto the rotor

The starter grip must be drawn firmly into the rope guide bush. If it tips sideways: increase the spring tension by another turn.

It must be possible to turn the rope rotor on another half-turn when the rope has been drawn out completely. If not, the spring has been tensioned too tightly and may break!

- Remove one turn of the rope from the rotor
- Install the fan housing
- Refit the shroud and tighten the screws

Replacing broken rewind spring

- Remove the rope rotor as described for "Replace torn starter rope"



The broken pieces of spring may still be under tension and can spring apart unexpectedly on removal from the fan housing – risk of injury! Wear face shield and protective gloves

- Carefully pry out the broken pieces of spring with a screwdriver
- Apply a few drops of non-resinous oil to the new replacement spring

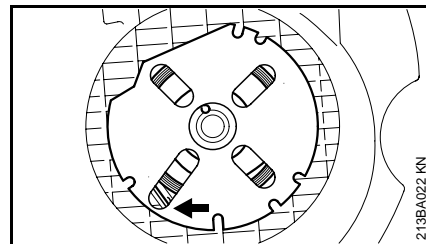

- Position the replacement spring with frame in the fan housing – the anchor loop (arrow) must be located over the retaining lug in the fan housing
- Apply suitable tools (screwdriver, punch, etc.) to the recesses and push the spring into its seat in the fan housing – the spring slides out of the frame
- Refit the rope rotor, tension the rewind spring
- Install the fan housing
- Refit the shroud and tighten the screws

Storing the Machine

For periods of 3 months or longer

- Drain and clean the fuel tank in a well ventilated area.
- Dispose of fuel properly in accordance with local environmental requirements.
- Run the engine until the carburetor is dry – this helps prevent the carburetor diaphragms sticking together.
- Remove the saw chain and guide bar, clean them and spray with corrosion inhibiting oil.
- Thoroughly clean the machine – pay special attention to the cylinder fins and air filter.
- If you use a biological chain and bar lubricant, e.g. STIHL BioPlus, completely fill the chain oil tank.
- Store the machine in a dry, high or locked location, out of the reach of children and other unauthorized persons.

Checking and Replacing the Chain Sprocket

- Remove chain sprocket cover, saw chain and guide bar.
- Release chain brake – pull hand guard against the front handle

Fit new chain sprocket

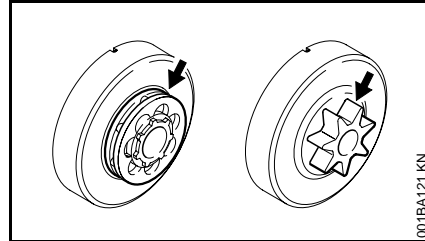

- after use of two saw chains or earlier
- if the wear marks (arrows) are deeper than 0.5 mm – otherwise the service life of the saw chain is reduced – use check gauge (special accessory) to test

Using two saw chains in alternation helps preserve the chain sprocket.

STIHL recommends use of original STIHL chain sprockets in order to ensure optimal functioning of the chain brake.

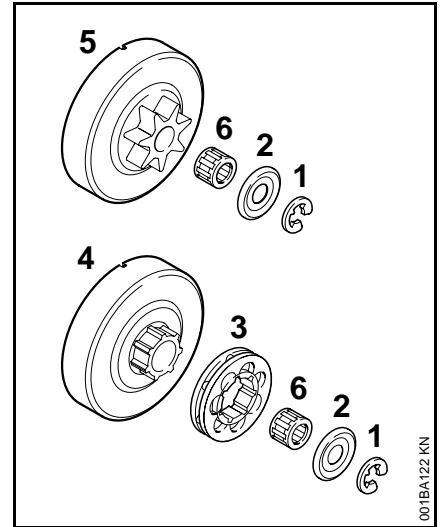

- Use a screwdriver to remove the E-clip (1)
- Remove the washer (2)
- Remove rim sprocket (3)
- Inspect transport profile on the clutch drum (4) – if there are also heavy signs of wear, also replace the clutch drum
- Remove clutch drum or spur chain sprocket (5) including needle cage (6) from the crankshaft – with QuickStop Super chain brake, press throttle lock beforehand

Install spur chain sprocket / rim sprocket

- Clean crankshaft stub and needle cage and lubricate with STIHL lubricant (special accessory)
- Slide needle cage onto the crankshaft stub
- After refitting, turn the clutch drum and/or spur chain sprocket approx. 1 full turn so that the carrier for the oil pump drive engages
- Refit the rim sprocket – cavities toward the outside
- Refit washer and E-clip on the crankshaft

Maintaining and Sharpening the Saw Chain

Sawing effortlessly with a properly sharpened saw chain

A properly sharpened saw chain cuts through wood effortlessly even with very little pushing.

Never use a dull or damaged saw chain – this leads to increased physical strain, increased vibration load, unsatisfactory cutting results and increased wear.

- Clean the saw chain
- Check the saw chain for cracks and damaged rivets.
- Replace damaged or worn chain components and adapt these parts to the remaining parts in terms of shape and level of wear – rework accordingly.

Carbide-tipped (Duro) saw chains are especially wear-resistant. For an optimal sharpening result, STIHL recommends STIHL servicing dealers.

 Compliance with the angles and dimensions listed below is absolutely necessary. An improperly sharpened saw chain – especially depth gauges that are too low – can lead to increased kickback tendency of the chain saw – **risk of injury!**

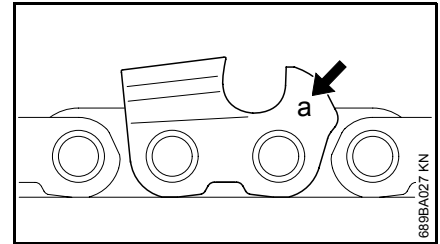

The chain pitch marking (**a**) is embossed in the area of the depth gauge of each cutter.

Marking (a)	Chain pitch	
	Inches	mm
1/4 or 1	1/4	6.35
P, PM or 6	3/8 P	9.32
325 or 2	0.325	8.25
3/8 or 3	3/8	9.32
404 or 4	0.404	10.26

Use only special saw chain files!

Other files are unsuitable in terms of shape and type of cutting.

The diameter of file to be used depends on the chain pitch – see table "Sharpening tools"

The angles of the cutter must be maintained during reshaping.

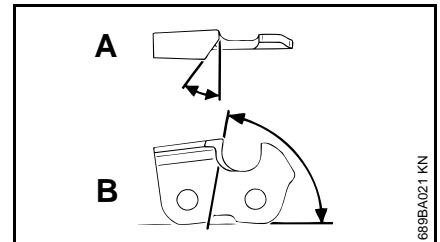

- A Sharpening angle
- B Side plate angle

Chain Type	Angle (°)	
	A	B
Rapid Micro (RM)	30	75
Rapid Super (RS)	30	60
Picco Micro (PM)	30	75
Rapid Micro X (RMX, ripping chain)	10	75
Picco Micro X (PMX, ripping chain)	10	75

Tooth shapes

Micro = semi-chisel tooth

Super = chisel tooth

When the specified files and/or sharpening tools and the proper setting are used, the specified values for angles A and B will be attained automatically.

The angles must be identical for all cutters in the saw chain. Varying angles: Rough, uneven running of the saw chain, increased wear – even to the point of saw chain breakage.

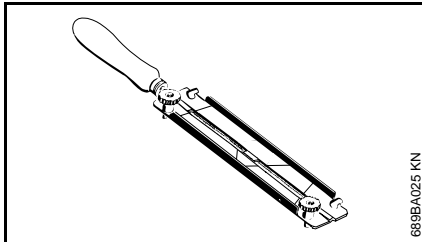

Because these requirements can be met only after sufficient, constant practice:

- **Use a file holder**

Always use a file holder (special accessory, see table "Sharpening tools") when sharpening saw chains by hand. File holders have markings for the sharpening angle.

To check the angles

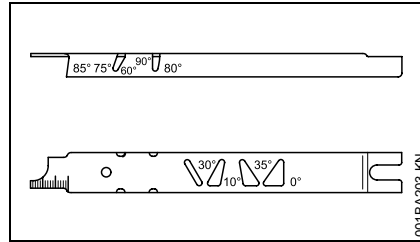

STIHL filing gauge (special accessory, see table "Sharpening tools") – a universal tool for checking sharpening and side plate angles, depth gauge setting, and tooth length, as well as cleaning grooves and oil inlet holes.

Proper sharpening

- Select sharpening tools in accordance with chain pitch
- Clamp guide bar if necessary
- Block saw chain – push the hand guard forward
- To advance the saw chain, pull the hand guard toward the handlebar: The chain brake is disengaged. With the Quickstop Super chain brake system, additionally press the throttle trigger lockout
- Sharpen frequently, removing little material – two or three strokes of the file are usually sufficient for simple resharping

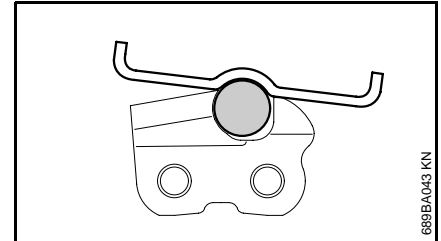
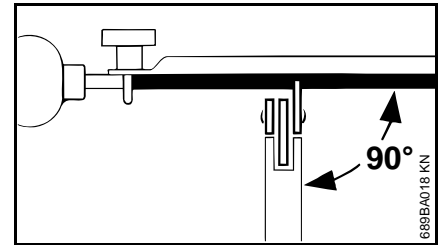

- Guide the file: **horizontally** (at a right angle to the side surface of the guide bar) in accordance with the specified angle – according to the markings on the file holder – rest the file holder on the tooth head and the depth gauge
 - File only from the inside outward
 - The file only sharpens on the forward stroke – lift the file on the backstroke
 - Do not file tie straps and drive links
 - Rotate the file a little periodically in order to avoid uneven wear
 - To remove file burr, use a piece of hardwood
 - Check angle with file gauge
- All cutters must be equally long.

With varying cutter lengths, the cutter heights also vary and cause rough running of the saw chain and chain breakage.

- All cutters must be filed down equal to the length of the shortest cutter – ideally, one should have this done in the workshop using an electric sharpener

Depth gauge setting

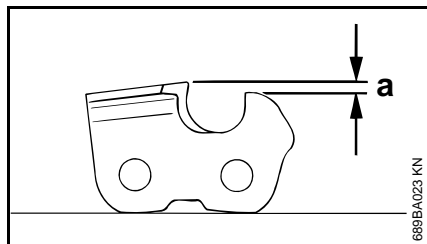

The depth gauge determines the depth to which the cutter penetrates the wood and thus the chip thickness.

- a Required distance between depth gauge and cutting edge

When cutting softwood outside of the frost season, the distance can be increased by up to 0.2 mm (0.008").

Chain pitch		Depth gauge Distance (a)	
Inches	(mm)	mm	(Inches)
1/4	(6.35)	0,65	(0.026)
3/8 P	(9.32)	0,65	(0.026)
0.325	(8.25)	0,65	(0.026)
3/8	(9.32)	0,65	(0.026)
0.404	(10.26)	0,80	(0.031)

Lowering the depth gauges

The depth gauge setting is lowered when the cutter is sharpened.

- Check the depth gauge setting after each sharpening

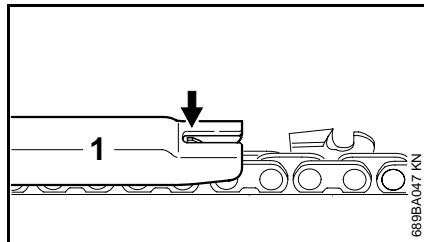

- Lay the appropriate file gauge for the chain pitch (1) on the saw chain and press it against the cutter to be checked – if the depth gauge protrudes past the file gauge, the depth gauge must be reworked

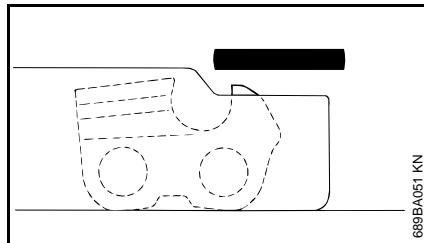

- Rework the depth gauge so that it is flush with the file gauge

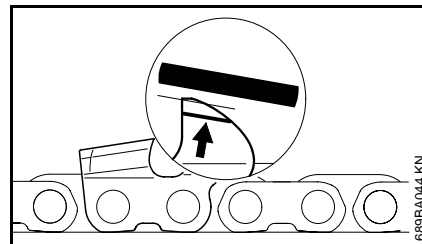

- Afterwards, dress the leading edge of the depth gauge parallel to the service mark (see arrow) – when doing this, be careful not to further lower the highest point of the depth gauge

 Depth gauges that are too low increase the kickback tendency of the chain saw.

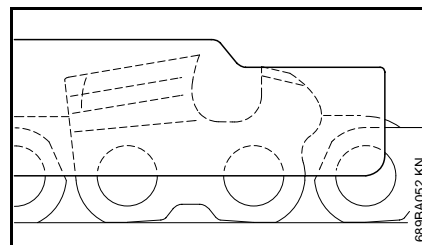

- Lay the file gauge on the saw chain – the highest point of the depth gauge must be flush with the file gauge

RSC3, RMC3, PMC3, PMMC3

The upper part of the humped drive link (with service mark) is lowered at the same time as the depth gauge of the cutter.

 The rest of the humped drive link must not be filed; otherwise, this could increase the tendency of the chain saw to kick back.

- After sharpening, clean the saw chain thoroughly, removing any filings or grinding dust – lubricate the saw chain thoroughly
- In the event of extended periods of disuse, store saw chains in cleaned and oiled condition

Sharpening tools (special accessories)

Chain pitch		Round file Ø		Round file	File holder	File gauge	Taper square file	Sharpening set ¹⁾
Inches	(mm)	mm	(Inches)	Part number	Part number	Part number	Part number	Part number
1/4	(6.35)	4.0	(5/32)	5605 772 4006	5605 750 4327	1110 893 4000	0814 252 3356	5605 007 1027
3/8 P	(9.32)	4.0	(5/32)	5605 772 4006	5605 750 4327	1110 893 4000	0814 252 3356	5605 007 1027
0.325	(8.25)	4.8	(3/16)	5605 772 4806	5605 750 4328	1110 893 4000	0814 252 3356	5605 007 1028
3/8	(9.32)	5.2	(13/64)	5605 772 5206	5605 750 4329	1110 893 4000	0814 252 3356	5605 007 1029
0.404	(10.26)	5.5	(7/32)	5605 772 5506	5605 750 4330	1106 893 4000	0814 252 3356	5605 007 1030

1) consisting of file holder with round file, taper square file and file gauge

Maintenance and Care

The following intervals apply to normal operating conditions only. If your daily working time is longer or operating conditions are difficult (very dusty work area, resin-rich wood, tropical wood, etc.), shorten the specified intervals accordingly. If you only use the saw occasionally, extend the intervals accordingly.		before starting work	after finishing work or daily	after each refueling stop	weekly	monthly	every 12 months	if problem	if damaged	if required
Complete machine	Visual inspection (condition, leaks)	X		X						
	Clean		X							
Throttle trigger, trigger interlock, Master Control	Check operation	X		X						
Chain brake	Check operation	X		X						
	Have checked by servicing dealer ¹⁾²⁾									X
Pickup body/filter in fuel tank	Check					X				
	Clean, replace filter element					X		X		
	Replace						X		X	X
Fuel tank	Clean					X				
Chain oil tank	Clean					X				
Chain lubrication	Check	X								
Saw chain	Inspect, also check sharpness	X		X						
	Check chain tension	X		X						
	Sharpen									X
Guide bar	Check (wear, damage)	X								
	Clean and turn over									X
	Deburr				X					
	Replace								X	X
Chain sprocket	Check				X					
Air filter	Clean							X		X
	Replace								X	
Antivibration elements	Check	X						X		
	Have replaced by dealer ¹⁾								X	

The following intervals apply to normal operating conditions only. If your daily working time is longer or operating conditions are difficult (very dusty work area, resin-rich wood, tropical wood, etc.), shorten the specified intervals accordingly. If you only use the saw occasionally, extend the intervals accordingly.		before starting work	after finishing work or daily	after each refueling stop	weekly	monthly	every 12 months	if problem	if damaged	if required
Cooling inlets	Clean		X							
Air inlet on fan housing	Clean		X		X					X
Cylinder fins	Clean		X		X					X
Preseparator port and carburetor body	Clean									X
"Carb preheat" shutter and preheating port	Clean (winter operation only)									X
Carburetor	Check idle adjustment – chain must not rotate	X		X						
	Readjust idle									X
Spark plug	Readjust electrode gap							X		
	Replace after every 100 operating hours									
All accessible screws and nuts (not adjusting screws) ³⁾	Retighten									X
Spark arresting screen ⁴⁾ in muffler	Check							X		
	Clean or replace								X	
Chain catcher	Check	X								
	Replace								X	
Safety labels	Replace								X	

¹⁾ STIHL recommends a STIHL servicing dealer.

²⁾ see chapter on "Chain Brake"

³⁾ Firmly tighten down the cylinder base screws of chain saws (3.4 kW or more) after 10 to 20 hours of operation.

⁴⁾ not in all versions, market-specific

Minimize Wear and Avoid Damage

Observing the instructions in this manual helps reduce the risk of unnecessary wear and damage to the power tool.

The power tool must be operated, maintained and stored with the due care and attention described in this owner's manual.

The user is responsible for all damage caused by non-observance of the safety precautions, operating and maintenance instructions in this manual. This includes in particular:

- Alterations or modifications to the product not approved by STIHL.
- Using tools or accessories which are neither approved or suitable for the product or are of a poor quality.
- Using the product for purposes for which it was not designed.
- Using the product for sports or competitive events.
- Consequential damage caused by continuing to use the product with defective components.

Maintenance Work

All the operations described in the "Maintenance Chart" must be performed on a regular basis. If these maintenance operations cannot be performed by the owner, they should be performed by a servicing dealer.

STIHL recommends that you have servicing and repair work carried out exclusively by an authorized STIHL

servicing dealer. STIHL dealers are regularly given the opportunity to attend training courses and are supplied with the necessary technical information.

If these maintenance operations are not carried out as specified, the user assumes responsibility for any damage that may occur. Among other parts, this includes:

- Damage to the engine due to neglect or deficient maintenance (e.g. air and fuel filters), incorrect carburetor adjustment or inadequate cleaning of cooling air inlets (intake ports, cylinder fins).
- Corrosion and other consequential damage resulting from improper storage.
- Damage to the machine resulting from the use of poor quality replacement parts.

Parts Subject to Wear and Tear

Some parts of the power tool are subject to normal wear and tear even during regular operation in accordance with instructions and, depending on the type and duration of use, have to be replaced in good time. Among other parts, this includes:

- Saw chain, guide bar
- Drive components (clutch, clutch drum, chain sprocket)
- Filters (air, oil, fuel)
- Starter mechanism
- Spark plug
- Components of antivibration system

Main Parts

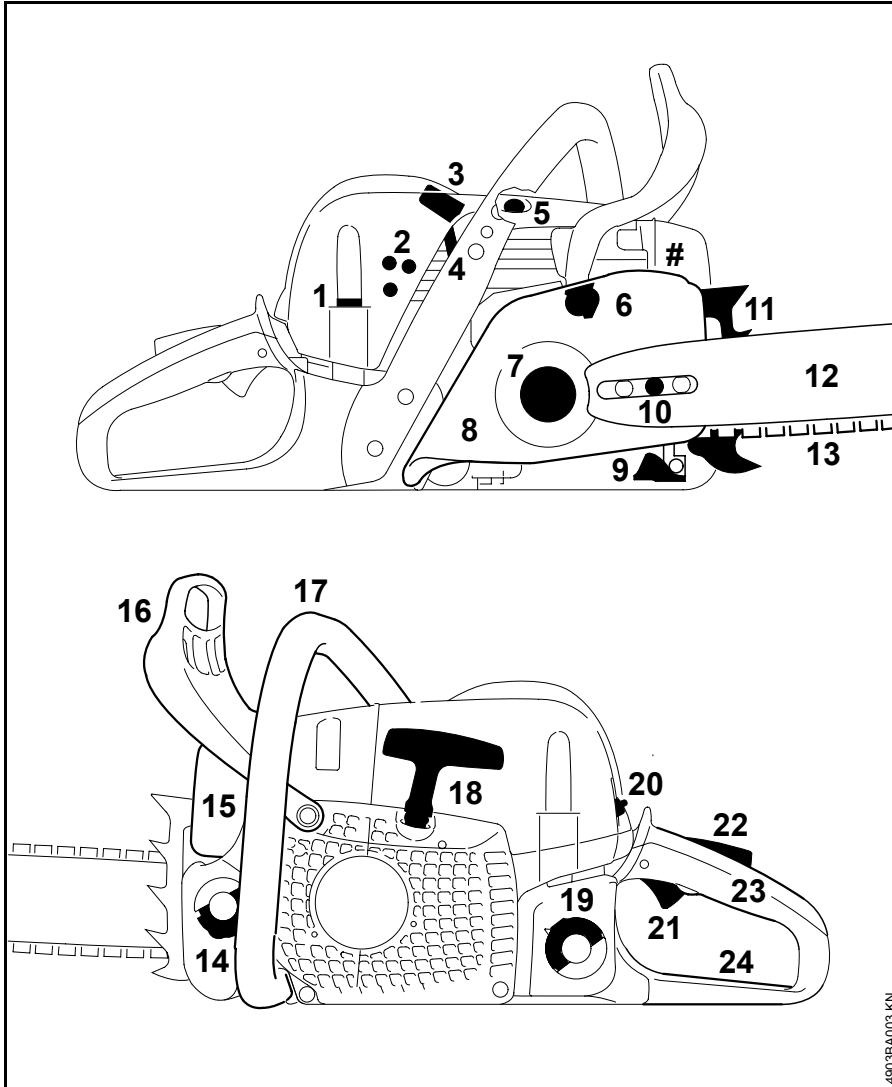

- 1 Shroud catch
- 2 Carburetor adjusting screws
- 3 Spark plug boot
- 4 Slide (summer operation and winter operation)
- 5 Decompression valve
- 6 Chain brake
- 7 Chain sprocket
- 8 Chain sprocket cover
- 9 Chain catcher
- 10 Side access chain tensioner
- 11 Bumper spike
- 12 Guide bar
- 13 Oilomatic saw chain
- 14 Oil filler cap
- 15 Muffler
- 16 Front hand guard
- 17 Front handle (handlebar)
- 18 Starter grip
- 19 Fuel tank twist lock
- 20 Master Control lever
- 21 Throttle trigger
- 22 Throttle trigger interlock
- 23 Rear handle
- 24 Rear hand guard
- # Serial number

4903BA003 KN

Specifications

Engine

STIHL single cylinder two-stroke engine

MS 311

Displacement:	59.0 cm ³
Bore:	47 mm
Stroke:	34 mm
Engine power to ISO 7293:	3.1 kW (4.2 HP) at 9500 rpm
Idle speed:	2800 rpm
Maximum permissible speed with bar and chain:	13000 rpm

MS 391

Displacement:	64.1 cm ³
Bore:	49 mm
Stroke:	34 mm
Engine power to ISO 7293:	3.3 kW (4.5 HP) at 9500 rpm
Idle speed:	2800 rpm
Maximum permissible speed with bar and chain:	13000 rpm

Ignition system

Electronic magneto ignition

Spark plug (suppressed):	Bosch WSR 6 F, NGK BPMR 7 A
Electrode gap:	0.5 mm

Fuel system

All position diaphragm carburetor with integral fuel pump

Fuel tank capacity: 0.60 l

Chain lubrication

Fully automatic, speed-controlled oil pump with reciprocating piston - additional manual oil flow control

Oil tank capacity: 0.350 l

Weight

dry, without bar and chain

MS 311: 6.4 kg

MS 391: 6.4 kg

Cutting attachment

Rollomatic E guide bars

Bar lengths:	37, 40, 45 cm
Pitch:	3/8" (9.32 mm)
Groove width:	1.6 mm
Sprocket nose:	10-tooth

Saw chains 3/8"

Rapid Micro Comfort (36 RMC)	
Rapid Super Comfort (36 RSC)	
Rapid Super Comfort 3 (36 RSC3)	
Pitch:	3/8" (9.32 mm)
Drive link gauge:	1.6 mm

Chain sprockets

7-tooth for 3/8" (rim sprocket)

Sound and vibration levels

The idle, full-throttle and nominal maximum speed are given equal consideration when calculating sound and vibration levels.

For further details concerning compliance with the employers' Directive on vibration 2002/44/EC, see www.stihl.com/vib/

Sound pressure level L_{peq} to ISO 22868

MS 311: 105 dB(A)

MS 391: 105 dB(A)

Sound power level L_{weq} to ISO 22868

MS 311: 115 dB(A)

MS 391: 115 dB(A)

Vibration level $a_{hv, eq}$ to ISO 22867

	Handle, left	Handle, right
MS 311:	4,0 m/s ²	4,0 m/s ²
MS 391:	4,0 m/s ²	4,0 m/s ²

The K-factor in accordance with Directive 2006/42/EC is 2.5 dB(A) for the sound pressure level and sound power level; the K-factor in accordance with Directive 2006/42/EC is 2.0 m/s² for the vibration measurement.

REACH

REACH is an EC regulation and stands for the Registration, Evaluation, Authorisation and Restriction of Chemical substances.

For information on compliance with the REACH regulation (EC) No. 1907/2006 see www.stihl.com/reach.

Special Accessories

Chain scabbard

If you use guide bars of different lengths on the saw, the length of the chain scabbard must be matched to the guide bar to help reduce the risk of injury.

If the chain scabbard does not cover the full length of the guide bar, a suitable chain scabbard or a scabbard extension is necessary.

Depending on the model, the scabbard extension either comes standard with the saw or is available as a special accessory.

Fitting the chain scabbard extension

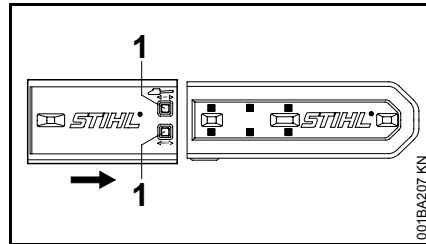

- Push the scabbard extension, locking tabs (1) first, onto the scabbard until the required length is obtained.

Other special accessories

- File holder with round file
- Filing gauge
- Reference gauges

- STIHL lubricating grease
- STIHL filler nozzle for fuel – helps avoid spills and overfilling during refueling
- STIHL filler nozzle for chain oil – helps avoid spills and overfilling

Contact your STIHL dealer for more information on these and other special accessories.

Ordering Spare Parts

Please enter your saw model, serial number as well as the part numbers of the guide bar and saw chain in the spaces provided. This will make re-ordering simpler.

The guide bar and saw chain are subject to normal wear and tear. When purchasing these parts, always quote the saw model, the part numbers and names of the parts.

Model

--	--	--	--	--	--	--	--	--	--	--	--	--	--	--	--	--	--	--	--

Serial number

--	--	--	--	--	--	--	--	--	--	--	--	--	--	--	--	--	--	--	--

Guide bar part number

--	--	--	--	--	--	--	--	--	--	--	--	--	--	--	--	--	--	--	--

Chain part number

--	--	--	--	--	--	--	--	--	--	--	--	--	--	--	--	--	--	--	--

Maintenance and Repairs

Users of this machine may only carry out the maintenance and service work described in this user manual. All other repairs must be carried out by a servicing dealer.

STIHL recommends that you have servicing and repair work carried out exclusively by an authorized STIHL servicing dealer. STIHL dealers are regularly given the opportunity to attend training courses and are supplied with the necessary technical information.

When repairing the machine, only use replacement parts which have been approved by STIHL for this power tool or are technically identical. Only use high-quality replacement parts in order to avoid the risk of accidents and damage to the machine.

STIHL recommends the use of original STIHL replacement parts.

Original STIHL parts can be identified by the STIHL part number, the **STIHL** logo and the STIHL parts symbol  (the symbol may appear alone on small parts).

EC Declaration of Conformity

ANDREAS STIHL AG & Co. KG
Badstr. 115
D-71336 Waiblingen

hereby confirms that

Model:	Chain saw
Make:	STIHL
Type:	MS 311 MS 391

Serial identification number:	1140
-------------------------------	------

Displacement

MS 311:	59.0 cm ³
---------	----------------------

MS 391:	64.1 cm ³
---------	----------------------

conforms to the specifications of Directives 2006/42/EC, 2004/108/EC and 2000/14/EC and has been developed and built in compliance with the following standards:

EN ISO 11681-1, EN 55012, EN 61000-6-1

The measured and guaranteed equivalent sound power level has been determined in accordance with Directive 2000/14/EC, Annex V, and standard ISO 9207.

Measured sound power level

MS 311:	117 dB(A)
---------	-----------

MS 391:	117 dB(A)
---------	-----------

Guaranteed sound power level

MS 311:	119 dB(A)
---------	-----------

MS 391:	119 dB(A)
---------	-----------

The EC type approval test was carried out at the

DPLF
Deutsche Prüf- und Zertifizierungsstelle
für Land- und Forsttechnik (NB 0363)
Max-Eyth-Weg 1
D-64823 Groß-Umstadt

Certification No.:

MS 311: K-EG-2009/5202

MS 391: K-EG-2009/5143

The technical documentation has been
retained by:

ANDREAS STIHL AG & Co. KG
Produktzulassung

The year of construction and the serial
number are shown on the machine.

Waiblingen, 17.06.2010

ANDREAS STIHL AG & Co. KG

pp.



Elsner

Head of Product Group Management

Quality Certification



All STIHL products comply with the
highest quality standards.

An independent organization has
certified that all products manufactured
by STIHL meet the strict requirements of
the ISO 9001 standard for quality
management systems in terms of
product development, materials
purchasing, production, assembly,
documentation and customer service.

0458-542-0121-B

englisch



www.stihl.com



0458-542-0121-B