



GÜNTHER

Hot Runner Systems

Control Unit

DPK2

User Manual

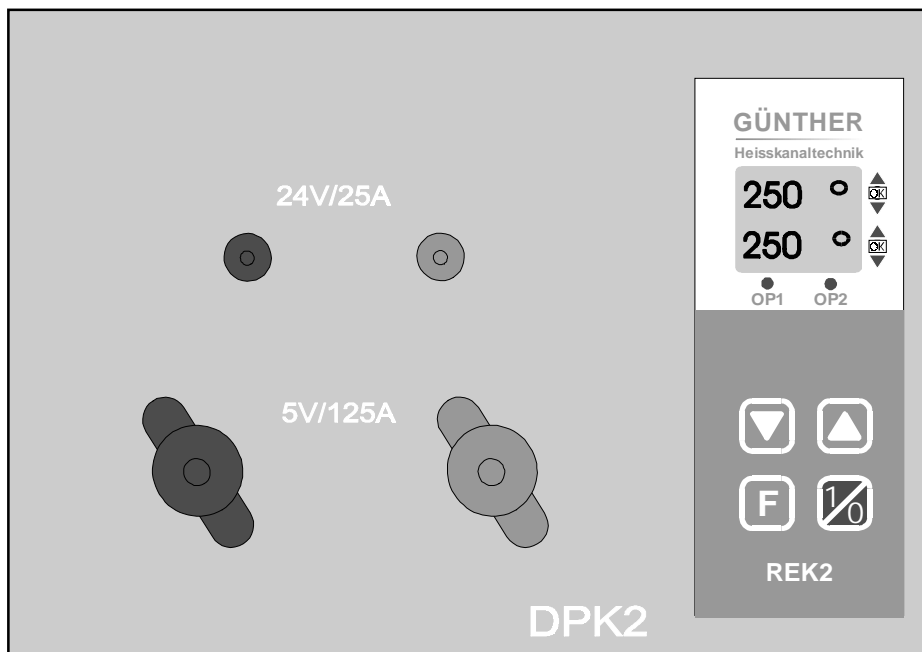

GUNTHER Hot Runner Control Unit DPK2

1. Safety Information

The DPK2 is built and tested according to safety standards declared by the European Council of Assimilation of Legal Regulations (cf. Appendix B) and has left the factory in perfect condition. In order to maintain this condition and for safe operation, please read this User Manual carefully and follow the instructions.

Ensure that your local supply voltage corresponds to the unit's nominal voltage before you switch on. For safe operation, the unit must be plugged into an earthed socket. Any disconnection of the earthed conductor, e.g. by using an extension flex without earthed conductor, may cause severe danger!

Caution: Always disconnect the unit before opening! Pull mains plug!

This control unit contains hazardous voltage. Any repair and service work must be carried out by qualified and authorized personnel only. The components inside the unit are maintenance-free for our customers. They are exclusively serviced by Gunther Hot Runner Systems.

For operation of the control unit, a protected socket must be used. The DPK2 is equipped with a 16A-shock-proof-plug. Please ensure that the sockets used are protected sufficiently.

Note:

Refer to the chapter on installation and start-up for further instructions on the connection of the potential-free fault output. Always unplug the unit before touching the components inside! (Pull mains plug!)

2. Operation

The 2-zone control unit DPK2 is designed for temperature regulation of two hot runner nozzles. It may be applied for the control of any 230V-load circuit and 5V and 24V low voltage nozzles of hot runner systems from GUNTHER. The first regulation zone 1 is a combinatorial one. You can control either low voltage nozzles or 230V-load circuits with this channel.

!! ATTENTION !!
connect on zone 1 at one time only one nozzle

The second regulation zone 2 can be used to control 230V-loads with a maximum load current of 10A (2300 W). The DPK2 shown in fig. 2.1 is equipped with one regulators type REK2. This is connected to the unit front and can be switched on and off with the red key "1/0".

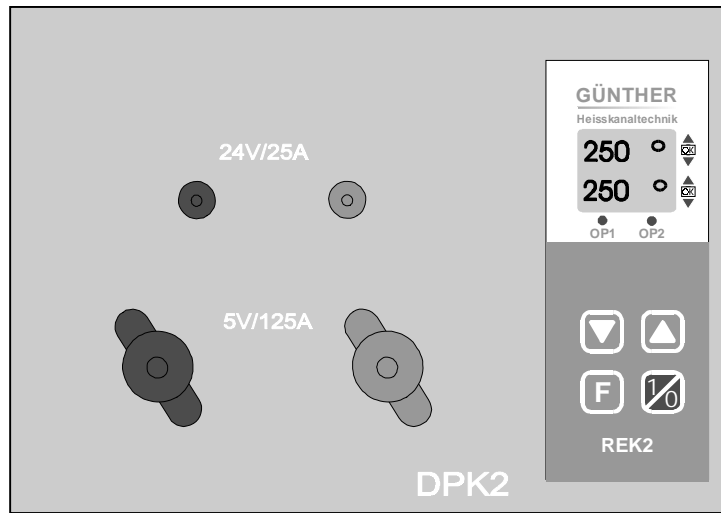

Fig. 2.1 Front View DPK2

The REK2 is easy-to-use: all possible functions of the REK2 can be performed via only three keys. Refer to the quick reference (Appendix B) for basic instructions on the operation of the REK2.

Please read the enclosed User Manual of the REK2 for a detailed description of the operation and the possible adjustments of this controller unit.

3. Connection of Control Circuits

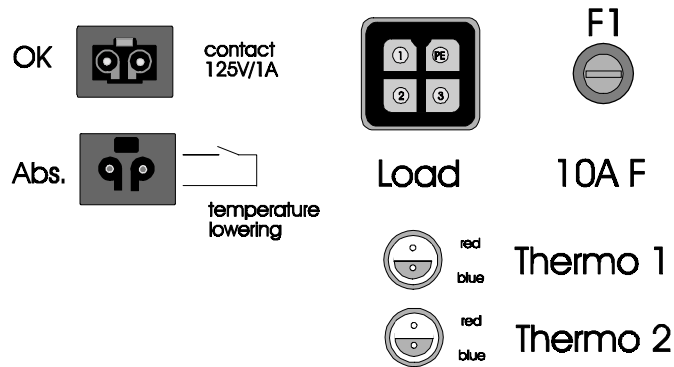

Fig. 3.1 Rear View DPK2 (Connection Plugs)

connector pin	1	2	3	PE
	output phase zone 1	output phase zone 2	output neutral	protection earth

Fig. 3.2 Load Connection of Control Unit DPK2

You can connect the heater circuit of both zones using the rearside 4-pin plug. Due to Fig. 3.2 the 230V output of zone 1 is connected to pin 1. Note that the maximum current on this combi zone is limited to 4A (900 W). The load fuse for this channel is placed on the regulation unit REK2.

The second channel „zone 2“ is able to control heater circuits up to 2000 W (max. 10A). The load fuse for this 230V nozzle is the 10AF fuse.

There are some clamp in front of the controller DPK2. The low current clamps (red and black) are for 24V nozzles. The high current clamps are for 5V nozzles.

!! ATTENTION !!
connect at one time only one nozzle

The two thermocouples for each control circuit must be connected to the two Lemosa sockets. The upper one is for control circuit zone 1 and the lower one is for zone 2.

3.1 "Ready for Injection"-Signal

The hot runner is ready for injection as soon as the control circuit is heated up to the required operating temperature. The REK2 display indicates "OK" for each control circuit and the potential-free relay contact is closed. For analysis of the moulding operation you may connect the potential-free relay contact to the control system of your machine.

Note: Only use extra-low voltage (max. 125V/1A) according to VDE standards (Germany) on the rear side OK-plug. The necessary equipment is available at Gunther Hot Runner Systems.

3.2 Temperature Lowering

During any long-term production halt it is advisable to lower the temperature of the zone. It is not necessary to adjust the temperature for the regulation zone – you can control the temperature of the zone simultaneously by means of a lowering input. If you close the two contacts of the lowering input with a switch or a potential-free contact, the set temperatures of the zone is lowered by a preset value.

For further information on the adjustment of the temperature, please read the REK2 User Manual.

3.3 Serial Interface

The standard configuration of the DPK2 includes an interface type RS232. This 9-pin plug is

positioned on the rear of the unit and allows direct connection of the DPK2 to a personal computer. The Windows-Software "DPCONTROL" makes the configuration and visualization of all system parameters possible. It will be provided by Gunther Hot Runner Systems as necessary.

The REK2 can be equipped with a potential-free interface module for standard types RS232, RS485 or TTY-20mA. However, for industrial applications, e.g. communication with machines type Arburg, Engel, etc., we recommend the use of an electrically isolated interface module.

4. Installation and Start-up

a) Installation

- Please position the unit where not heat accumulation will occur.
- The load fuse may not exceed 10A.
- Ensure that the sockets are sufficiently protected for connecting 16A

b) Start-up

- To connect the heating circuit and thermocouples, plug in load connectors.
- Plug in mains plug for power supply.
- Press master key.
- Switch on each REK2 by pressing the red key(s) "1/0".
- Set the desired set temperatures of all zones.
- During initial start-up you should activate each control point separately so that possible faulty connection of either load or thermoelectric couple may be detected.
- After switching on the control unit, please wait for a few minutes until the tool is heated up evenly.

5. Table of Faults and Defects

During the course of the operation, the REK2 is continually checking the control circuit for faults and defects. Any fault/defect detected is indicated on the display.

		Fault/Defect	Possible Cause	Countermeasure
A	Fault report "no sensor 1"	Thermocouple of zone 1 or 3 defect	Thermocouple is not connected or interrupted	Check connection plug and -cable of thermoelectric couple
B	Fault report "no sensor 2"	Thermocouple of zone 2 or 4 defect	Thermocouple is not connected or interrupted	Check connection plug and -cable of thermoelectric couple
C	Fault report "Pol. TH 1"	Polarity error at thermocouple of zone 1 or 3	Polarity error at the thermo couple	Correct the polarity
D	Fault report "Pol. TH 2"	Polarity error at thermocouple of zone 1 or 3	Polarity error at the thermo couple	Correct the polarity
E	Fault report "no load 1"	Load circuit of zone 1 or 3 interrupted	Fuse blown Load not connected	Exchange fuse Check connecting cable
F	Fault report "no load 2"	Load circuit of zone 2 or 4 interrupted	Fuse blown Load not connected	Exchange fuse Check connecting cable
G	Significant fluctua- tion of temperature (+/- 100 °C)		Thermocouple defect or load circuit not earthed	Check earthing of load circuit
H	Temperature in-		Load circuit	Check assignment of

	crease not satis- factory		(swapped)	heater circuit to thermoelectric couple
--	--------------------------------------	--	------------------	--

Caution:

With 230V-runners the heater circuits must be earthed sufficiently. Lack of earthing or insufficiently earthed tool/heating element may cause severe errors in the temperature reading.

6. Specifications

Nominal Voltage:	220 to 240V AC, 50/60Hz
Nominal Capacity :	3000 W, 1 x 230V/10A, 1x 230V/4A
Stand-by Capacity :	approx. 10 VA
Load Connection zone 1:	- heater circuit 230V / 4A, harting connector series HAN 3A - 24V heater circuit 10V / 25A, low current clamp 4mm - 5V heater circuit 3,7V / 125A, high current clamp
Load Connection zone 2:	heater circuit 230V / 10A, harting connector series HAN 3A
Mains Plug :	3m, 16A-shock-proof-plug
Thermocouple Connection:	Thermoelectric couple type L (FeCuNi), lemosa
OK Output:	Potential-free closing contact (max. 125V/1A not secured by fuse)
Lowering Input:	Connect a potential-free contact normally open
Fuses:	zone 2 : FF 10A type Schurter Typ SA; superfast for Triacs Zone 1: F 6,3A
Serial Interface:	Standard: RS232; optional: electrically isolated TTY, RS422, RS485
Regulation:	"Pulsgruppensteuerung" (Switching Power Control) for 230V Phaseangle for low voltage load
Storage Temperature:	up to 70°C
Operating Temperature:	up to 35°C
Protection Type:	IP 20
Dimensions (W, H, D):	150mm x 150mm x 330mm
Colour:	grey and blue (RAL 9018 und RAL 5015)

7. Appendices

- Appendix A
Quick Reference REK2

- Appendix B
Declaration of Conformity

Quick Reference REK2

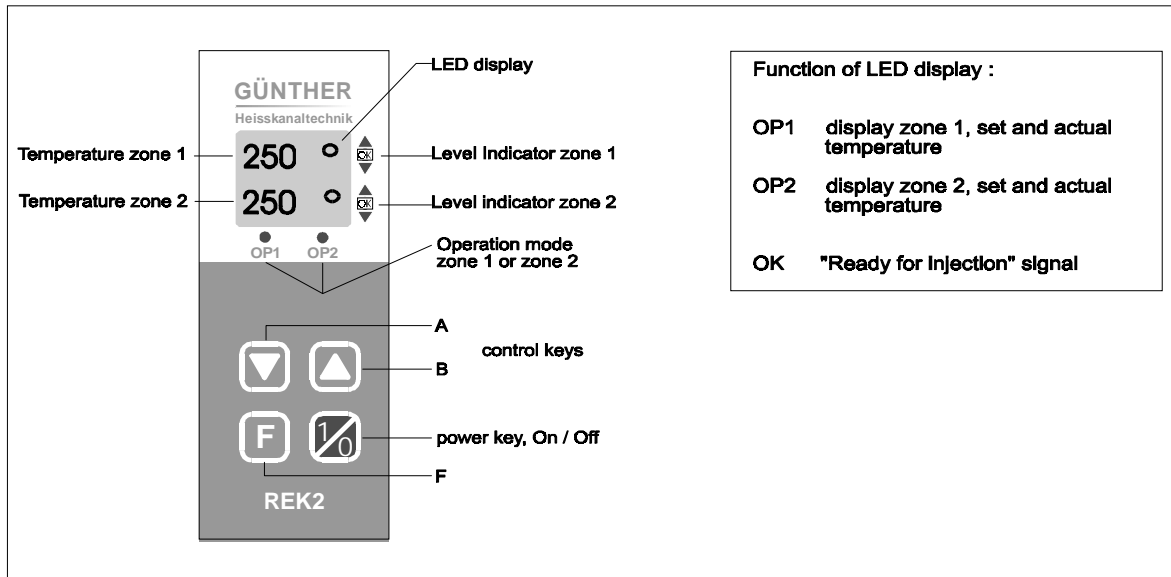

Fig. A.1 Operation Control Panel

The REK2 will be switched on by pressing the key "1/0" ("ON/OFF"). By pressing the key 1/0 ("ON/OFF") again, the unit is switched off. This key has no further functions.

KEY	Operation Mode	Parameter Menu	Key held down during switch-on
N			
A	count-down of set value	parameter number count-down	
B	count-up of set value	parameter number count-up	
F	Enter parameter Menu	chose next menu item	
A & B	Switching between zone displays		
A & B & F			Load default values (standard configuration off-factory)

Fig. A.2 Keys: Brief Operating Instructions

Appendix B: EG – Declaration of Conformity

For the following below listed products:

Günther-Hot Runner Controller DPK2

we hereby confirm, that above listed products comply to all important (*) safety requirements that have been declared by the Council of Assimilation of Legal Regulations by the EC membership countries concerning electromagnetic conformity (89/336/EWG).

To verify these products to electromagnetic conformity the following standards were referred to:

**EN 50081, Part 2
EN 50082, Part 2**

The above mentioned products also comply to:

DIN EN 61010, Teil 1/03.94.

This declaration applies to all above listed products with the following production index:

Production Index A

The production index is the number behind the serial number on the identification label of the product. The identification label is located on the right side of the product.

**DAVIDSMEYER & PAUL GmbH Elektronik
Humboldtstr.2-4
D-50181 Bedburg**

Bedburg, 19.11.1997

**J. Marquardt
(Managing Director)**

(*) Expressions recommended by "EMV-Rechtsvorschriften und ihre Anwendung in der Praxis", Franzis-Verlag, 1993