



**Series APC8620/8621 Industrial I/O Pack
PCI Bus Non-Intelligent Carrier Board**

USER'S MANUAL

ACROMAG INCORPORATED

**30765 South Wixom Road
P.O. BOX 437
Wixom, MI 48393-7037 U.S.A.
Tel: (248) 624-1541
Fax: (248) 624-9234**

Copyright 2000, Acromag, Inc., Printed in the USA.
Data and specifications are subject to change without notice.

8500-576-E01B010

The information contained in this manual is subject to change without notice. Acromag, Inc. makes no warranty of any kind with regard to this material, including, but not limited to, the implied warranties of merchantability and fitness for a particular purpose. Further, Acromag, Inc. assumes no responsibility for any errors that may appear in this manual and makes no commitment to update, or keep current, the information contained in this manual. No part of this manual may be copied or reproduced in any form, without the prior written consent of Acromag, Inc.

Table of Contents	Page
1.0 GENERAL INFORMATION	2
KEY APC8620/8621 FEATURES	2
PCI BUS INTERFACE FEATURES	3
SIGNAL INTERFACE PRODUCTS	3
IP MODULE OLE CONTROL SOFTWARE	3
2.0 PREPARATION FOR USE	3
UNPACKING AND INSPECTION	3
CARD CAGE CONSIDERATIONS	4
BOARD CONFIGURATION	4
Interrupt Configuration	4
CONNECTORS	4
Carrier Field I/O Connectors (IP modules A-E)	4
IP Field I/O Connectors (IP modules A-E)	4
IP Logic Interface Connectors (IP modules A-E)	4
IP Logic Strobe Connectors	4
PCI BUS Connections	5
DATA TRANSFER TIMING	5
FIELD GROUNDING CONSIDERATIONS	6
3.0 PROGRAMMING INFORMATION	6
PCI Configuration Address Space	6
Configuration Transactions	6
Configuration Registers	7
MEMORY MAP	7
Carrier Board Status Register	8
IP Interrupt Pending Register	8
IP Module Interrupt Space	8
IP Module ID Space	8
IP Module I/O Space	9
GENERATING INTERRUPTS	9
Sequence of Events for an Interrupt	9
4.0 THEORY OF OPERATION	9
CARRIER BOARD OVERVIEW	9
PCI BUS Interface	9
Carrier Board Registers	9
IP Logic Interface	10
Carrier Board Clock Circuitry	10
PCI Interrupter	10
Power Failure Monitor	10
Power Supply Fuses	10
Power Supply Filters	10
5.0 SERVICE AND REPAIR	10
SERVICE AND REPAIR ASSISTANCE	10
PRELIMINARY SERVICE PROCEDURE	10
6.0 SPECIFICATIONS	11
GENERAL SPECIFICATIONS	11
PCI BUS COMPLIANCE	11
INDUSTRIAL I/O PACK COMPLIANCE	11
ENVIRONMENTAL	12

APPENDIX	12
CABLE: MODEL 5025-550	12
CABLE: MODEL 5025-551	12
CABLE: MODEL 5029-943	12
TERMINATION PANEL: MODEL 5025-552	12

DRAWINGS	Page
4501-671 APC8620 IP LOCATIONS	13
4501-676 APC8621 IP LOCATIONS	14
4501-672 MECHANICAL ASSEMBLY DRAWING	15
4501-673 APC8620/8621 BLOCK DIAGRAM	16
4501-462 CABLE 5025-550 (NON-SHIELDED)	17
4501-463 CABLE 5025-551 (SHIELDED)	18
4501-464 TERMINATION PANEL 5025-552	19

IMPORTANT SAFETY CONSIDERATIONS

It is very important for the user to consider the possible adverse effects of power, wiring, component, sensor, or software failures in designing any type of control or monitoring system. This is especially important where economic property loss or human life is involved. It is important that the user employ satisfactory overall system design. It is agreed between the Buyer and Acromag, that this is the Buyer's responsibility.

1.0 GENERAL INFORMATION

The APC8620/8621 card is a personal computer Peripheral Component Interconnect (PCI) bus card and is a carrier for the Industrial I/O Pack (IP) mezzanine board field I/O modules. The carrier board provides a modular approach to system assembly, since each carrier can be populated with any combination of analog input/output, digital input/output, communication, etc. IP modules. Thus, the user can create a board which is customized to the application. This saves money and space - a single carrier board populated with IP modules may replace several dedicated function PCI bus boards. The APC8620/8621 non-intelligent carrier board provides impressive functionality at low cost.

Model	Board Size (Length)	Supported IP Slots	Operating Temperature Range
APC8620	Long (12.283")	5(A,B,C,D,E)	0 to +70°C
APC8620E	Long (12.283")	5(A,B,C,D,E)	-40 to +85°C
APC8621	Short (6.600")	3(A,B,C)	0 to +70°C
APC8621E	Short (6.600")	3(A,B,C)	-40 to +85°C

KEY APC8620/8621 FEATURES

- **PCI Specification Version 2.1 Compliant Slave Carrier:** - Provides a PCI bus interface to control and communicate with industry standard IP modules.
- **Interface for IP Modules** – APC8620 provides an electrical and mechanical interface for up to five industry standard IP modules. APC8621 provides an electrical and mechanical interface for up to three industry standard IP modules. IP Modules are available from Acromag and other vendors in a wide variety of Input/Output configurations to meet the needs of varied applications.
- **Plug-And-Play PCI bus Carrier** - The carrier card contains standard PCI bus configuration memory. Upon power-up

the system auto-configuration process assigns the carrier's base address in memory space.

- **Plug-And-Play Interrupt Support** - The personal computer system software will allocate one interrupt line to the carrier. The carrier's interrupt pending register can be used to quickly identify IP module pending interrupts.
- **Supports Two Interrupt Channels per IP** - Up to two interrupt requests are supported for each IP. Additional registers are associated with each interrupt request for control and status monitoring.
- **Full IP Register Access** - Makes maximum use of logically organized programmable registers on the carrier boards to provide for easy configuration and control of IP modules. Supports accesses to IP input/output, interrupt, and ID ROM data spaces. No hardware jumper settings are required on the carrier board.
- **IP Module Access Time Out** - Allows access to empty IP slots without system failure. If the IP module accessed does not respond within 32µ seconds the bus access is terminated without system failure. This allows each IP slot to be probed to determine if an IP is installed. A control register bit will be set and/or issue of an interrupt request to indicate IP module time out access has occurred.
- **Optional Screw Termination Panel** - Model supports field connection via screw terminals using the optional DIN rail mount termination panels.
- **Connectors Access I/O** - Access to field I/O signals is provided via industry standard 50-pin headers with ejector latches. A separate header is provided for each IP module.
- **Supervisory Circuit for Reset Generation** - A microprocessor supervisor circuit provides power-on, power-off, and low power detection reset signals to the IP modules per the IP specification.
- **Individually Filtered Power** - Filtered +5V, +12V, and -12V DC power is provided to the IP modules via passive filters present on each supply line serving each IP. This provides optimum filtering and isolation between the IP modules and the carrier board and allows analog signals to be accurately measured or reproduced on IP modules without signal degradation from the carrier board logic signals.
- **Individually Fused Power** - Fused +5V, +12V, and -12V DC power is provided. A fuse is present on each supply line serving each IP module.
- **OLE Control Software is Available** - Acromag provides Object Linking and Embedding (OLE) controls software for Windows 95/98/NT™. This software (Model IPSW-OLE-PCI, MSDOS format) provides individual drivers that allow IP modules and our personal computer carriers to be easily integrated into Windows application programs, such as Visual C++, Visual Basic, Borland Delphi™, Microsoft® Office 97® applications, and others.

PCI BUS INTERFACE FEATURES

- **Slave Module**- All read and write accesses are implemented as either a 32-bit, 16-bit or 8-bit single data transfer.
- **Immediate Disconnect on Read** - The PCI bus will immediately disconnect after a read. The read data is then stored in a read FIFO. Data in the read FIFO is then accessed by the PCI bus when the read cycle is retried. This allows the PCI bus to be free for other system operations while the read data is moved to the read FIFO.
- **Interrupt Support** - PCI bus INTA# interrupt request is supported. All IP module interrupts are mapped to INTA#. Carrier board software programmable registers are utilized as interrupt request control and status monitors.

SIGNAL INTERFACE PRODUCTS

(See Appendix for more information on compatible products)

This IP carrier board will mate directly to all industry standard IP modules. Acromag provides the following interface products (all connections to field signals are made through the carrier board which passes them to the individual IP modules):

Cables:

Model 5025-551-X (Shielded Cable) or Model 5025-550-X (Non-Shielded Cable): A Flat 50-pin cable with female connectors at both ends for connecting carrier boards, to Model 5025-552 termination panels. The unshielded cable is recommended for digital I/O, while the shielded cable is recommended for optimum performance with precision analog I/O applications.

Model 5029-943 IP500 Serial Communication Cable: A 5 foot long, flat 50-pin cable with a female connector on one end (for connection to the carrier board) and four DE-9P connectors (serial ports) on the other end. Also used for interface with Acromag Model IP501 (RS-422) & IP502 (RS-485) serial communication modules.

Termination Panel:

Model 5025-552: DIN-rail mountable panel provides 50 screw terminals for universal field I/O termination. Connects to carrier boards, via flat 50-pin ribbon cable (Model 5025-550-X or 5025-551-X).

IP MODULE OLE CONTROL SOFTWARE

Acromag provides a software product (sold separately) consisting of IP module OLE (Object Linking and Embedding) drivers for Windows 95/98/NT compatible application programs (Model IPSW-OLE-PCI, MSDOS format). This software provides individual drivers that allow Acromag IP modules and our personal computer carriers to be easily integrated into Windows application programs, such as Visual C++, Visual Basic, Borland Delphi™, Microsoft® Office 97® applications, and others. The OLE controls provide a high-level interface to IP modules, eliminating the need to perform low-level reads/writes of registers, and the writing of interrupt handlers—all the complicated details of programming are handled by the OLE controls. These functions are intended for use in conjunction with an Acromag personal computer carrier and consist of a carrier OLE control, and an OLE control for each Acromag IP module as well as a generic OLE control for non-Acromag IP modules.

2.0 PREPARATION FOR USE

UNPACKING AND INSPECTION

Upon receipt of this product, inspect the shipping carton for evidence of mishandling during transit. If the shipping carton is badly damaged or water stained, request that the carrier's agent be present when the carton is opened. If the carrier's agent is absent when the carton is opened and the contents of the carton are damaged, keep the carton and packing material for the agent's inspection.

For repairs to a product damaged in shipment, refer to the Acromag Service Policy to obtain return instructions. It is suggested that salvageable shipping cartons and packing material be saved for future use in the event the product must be shipped.



This board is physically protected with packing material and electrically protected with an anti static bag during shipment. It is recommended that the board be visually inspected for evidence of mishandling prior to applying power.

The board utilizes static sensitive components and should only be handled at a static-safe workstation.

CARD CAGE CONSIDERATIONS

Refer to the specifications for loading and power requirements. Be sure that the system power supplies are able to accommodate the power requirements of the carrier board, plus the installed IP modules, within the voltage tolerances specified.

IMPORTANT: Adequate air circulation must be provided to prevent a temperature rise above the maximum operating temperature.

The lack of air circulation within the computer chassis is a cause for some concern. Most, if not all, computer chassis do not provide a fan for cooling of add-in boards. The dense packing of the IP modules to the carrier board alone results in elevated IP module and carrier board temperatures, and the restricted air flow within the chassis aggravates this problem. Adequate air circulation must be provided to prevent a temperature rise above the maximum operating temperature and to prolong the life of the electronics. If the installation is in an industrial environment and the board is exposed to environmental air, careful consideration should be given to air-filtering.

BOARD CONFIGURATION

The carrier board is plug-and-play compatible and, as such, its board addresses are automatically assigned by the system auto-configuration routine upon power-up. The base address of the carrier board's configuration registers in memory space and I/O space is assigned. In addition, the base address of the IP modules and carrier board registers are assigned in 32-bit memory space.

Power should be removed from the board when installing IP modules, cables, termination panels, and field wiring. Refer to Mechanical Assembly Drawing 4501-672 and your IP module documentation for specific configuration and assembly instructions.

Interrupt Configuration

No hardware jumper configuration is required. All interrupt enabling, and status are configured via programmable registers on the carrier board (see Section 3 for programming details). The carrier board passes interrupt requests from the IP modules to the PCI bus. Refer to the IP modules for their specific configuration requirements.

CONNECTORS

Connectors of the APC8620 carrier consist of five (three for APC8621) carrier IP module field I/O connectors, five (three for

APC8621) IP module logic connectors, and one PCI bus interface connector. These interface connectors are discussed in the following sections.

Carrier Field I/O Connectors (IP modules A through E)

Field I/O connections are made via 50 pin ribbon cable connectors A, B, C, D, and E (A, B, and C for APC8621) for IP modules in positions A through E (A through C for APC8621). IP module assignment is marked on the board for easy identification (see IP location drawing 4501-671 or 4501-676 for physical locations of the IP modules). Flat cable assemblies and Acromag termination panels (or user defined terminations) can be quickly mated to the field I/O connectors. Pin assignments are defined by the IP module employed since the pins from the IP module field side correspond identically to the pin numbers of the 50 pin connectors.

Carrier field I/O connectors A through E (A through C for APC8621) are industry standard 50-pin low profile headers (male) with short ejector latches (no ejector latches for APC8621) and they mate to ribbon cable connectors (3M Type P/N 3425-6600).

IP Field I/O Connectors (IP modules A through E)

The field side connectors of IP modules A through E (A through C for APC8621) mate to AMP 173280-3 connectors P4, P5, P9, P12, and P15 (P3, P6, and P9 for APC8621) respectively, on the carrier board. IP location is silk-screened on the board for easy identification. Field and logic side connectors are keyed to avoid incorrect assembly.

The AMP 173280-3 connectors mate to AMP 173279-3 connectors (or similar) on the IP modules. This provides excellent connection integrity and utilizes gold plating in the mating area. Threaded metric M2 screws and spacers (supplied with Acromag IP modules) provide additional stability for harsh environments (see Drawing 4501-672 for assembly details).

Pin assignments for these connectors are made by the specific IP model used and correspond identically to the pin numbers of the front panel connectors.

IP Logic Interface Connectors (IP modules A through E)

The logic interface sides of IP modules A through E (A through C for APC8621) mate to AMP 173280-3 connectors P6, P7, P10, P13, and P16 (P4, P7, and P10 for APC8621), respectively, on the carrier board. IP location is silk-screened on the board for easy identification. Field and logic side connectors are keyed to avoid incorrect assembly.

The AMP 173280-3 connectors mate to AMP 173279-3 connectors (or similar) on the IP modules. This provides excellent connection integrity and utilizes gold plating in the mating area. Threaded metric M2 screws and spacers (supplied with Acromag IP modules) provide additional stability for harsh environments (see Drawing 4501-672 for assembly details).

Pin assignments for these connectors are defined by the IP module specification and are shown in Table 2.1.

IP Logic Strobe Connectors

Each IP module has an uncommitted Strobe signal on the logic interface connector (pin 46). The Strobe signal may be used as an optional input or output from the IP module. On the APC8620 the Strobe signals for each of the five IP modules are routed on the printed circuit board to the location just above the

IP module D and E field connectors (as shown in Drawing 4501-671). On the APC8621 the Strobe signals for each of the three IP modules are routed on the printed circuit board to the location just above of IP module C field connector (as shown in Drawing 4501-676). The factory default is to leave these signals unconnected.

Table 2.1: Standard IP Logic Interface Connections

Pin Description	Number	Pin Description	Number
GND	1	GND	26
CLK	2	+5V	27
Reset*	3	R/W*	28
D00	4	IDSEL*	29
D01	5	DMAReq0*	30
D02	6	MEMSEL*	31
D03	7	DMAReq1*	32
D04	8	IntSel*	33
D05	9	DMAck0*	34
D06	10	IOSEL*	35
D07	11	RESERVED	36
D08	12	A1	37
D09	13	DMAEnd*	38
D10	14	A2	39
D11	15	ERROR*	40
D12	16	A3	41
D13	17	INTRReq0*	42
D14	18	A4	43
D15	19	INTRReq1*	44
BS0*	20	A5	45
BS1*	21	STROBE*	46
-12V	22	A6	47
+12V	23	ACK*	48
+5V	24	RESERVED	49
GND	25	GND	50

Asterisk (*) is used to indicate an active-low signal.
BOLD ITALIC Logic Lines are NOT USED by the carrier board.

PCI Bus Connections

Table 2.2 indicates the pin assignments for the PCI bus signals at the card edge connector. Connector pins are designated by a letter and a number. The letter indicates which side of a particular connector the pin contact is on. "B" is on the component side of the carrier board while "A" is on the solder side. Connector "gold finger" numbers increase with distance from the bracket end of the printed circuit board.

Refer to the PCI bus specification for additional information on the PCI bus signals.

TABLE 2.2: PCI Bus P1 CONNECTIONS

Signal	Pin	Pin	Signal
-12V	B01	A01	TRST#
TCK	B02	A02	+12V
Ground	B03	A03	TMS
TDO	B04	A04	TDI
+5V	B05	A05	+5V
+5V	B06	A06	INTA#
INTB#	B07	A07	INTC#
INTD#	B08	A08	+5V
PRSENT1#	B09	A09	Reserved
Reserved	B10	A10	+5V
PRSENT2#	B11	A11	Reserved

Bracket End ↑

Signal	Pin	Pin	Signal
Ground	B12	A12	Ground
Ground	B13	A13	Ground
Reserved	B14	A14	Reserved
Ground	B15	A15	RST#
CLK	B16	A16	+5V
Ground	B17	A17	GNT#
REQ#	B18	A18	Ground
+5V	B19	A19	Reserved
AD[31]	B20	A20	AD[30]
AD[29]	B21	A21	+3.3V
Ground	B22	A22	AD[28]
AD[27]	B23	A23	AD[26]
AD[25]	B24	A24	Ground
+3.3V	B25	A25	AD[24]
C/BE[3]#	B26	A26	IDSEL
AD[23]	B27	A27	+3.3V
Ground	B28	A28	AD[22]
AD[21]	B29	A29	AD[20]
AD[19]	B30	A30	Ground
+3.3V	B31	A31	AD[18]
AD[17]	B32	A32	AD[16]
C/BE[2]#	B33	A33	+3.3V
Ground	B34	A34	FRAME#
IRDY#	B35	A35	Ground
+3.3V	B36	A36	TRDY#
DEVSEL#	B37	A37	Ground
Ground	B38	A38	STOP#
LOCK#	B39	A39	+3.3V
PERR#	B40	A40	SDONE
+3.3V	B41	A41	SBO#
SERR#	B42	A42	Ground
+3.3V	B43	A43	PAR
C/BE[1]#	B44	A44	AD[15]
AD[14]	B45	A45	+3.3V
Ground	B46	A46	AD[13]
AD[12]	B47	A47	AD[11]
AD[10]	B48	A48	Ground
Ground	B49	A49	AD[09]
KEYWAY			KEYWAY
KEYWAY			KEYWAY
AD[08]	B52	A52	C/BE[0]#
AD[07]	B53	A53	+3.3V
+3.3V	B54	A54	AD[06]
AD[05]	B55	A55	AD[04]
AD[03]	B56	A56	Ground
Ground	B57	A57	AD[02]
AD[01]	B58	A58	AD[00]
+5V	B59	A59	+5V
ACK64#	B60	A60	REQ64#
+5V	B61	A61	+5V
+5V	B62	A62	+5V

(#) s used to indicate an active-low signal.
BOLD ITALIC Logic Lines are NOT USED by the carrier board.

DATA TRANSFER TIMING

All PCI bus read or write cycles to the APC8620/8621 are typically implemented within 150n seconds (FRAME# active to TRDY# active). After 150n seconds the PCI bus is available to the system for other PCI bus activity. As the PCI bus is released, the APC8620/8621 completes the read or write cycle to the targeted IP module or carrier register within the access times given in Table 2.3.

TABLE 2.3: APC8620/8621 Write and Read Complete Time

Register	Data Transfer Time
Carrier Registers Write	650nS, Typical ¹
8 and 16-bit IP Write	750nS, Typical ^{1,2}
32-bit IP Write	1250nS, Typical ^{1,3}
Carrier Register Read	500nS, Typical ¹
8 and 16-bit IP Read	650nS, Typical ^{1,2}
32-bit IP Read	1100nS, Typical ^{1,3}

Notes (Table 2.3):

1. The data transfer times given in table 2.3 are measured from the falling edge of FRAME# to the falling edge of LRDYi#. The PCI bus starts a data transfer cycle by driving FRAME# low. The APC8620/8621 signals the completion of a read or write cycle by driving LRDYi# low.
2. This access time assumes zero IP module wait states. For each IP module wait state 125n seconds must be added to this value.
3. This access time assumes zero IP module wait states. For each IP module wait state 250n seconds must be added to this value.

FIELD GROUNDING CONSIDERATIONS

Carrier boards are designed with passive filters on each supply line to each IP module. This provides maximum filtering and signal decoupling between the IP modules and the carrier board. However, the boards are considered non-isolated, since there is electrical continuity between the PCI bus and the IP grounds. Therefore, unless isolation is provided on the IP module itself, the field I/O connections are not isolated from the PCI bus. Care should be taken in designing installations without isolation to avoid ground loops and noise pickup. This is particularly important for analog I/O applications when a high level of accuracy/resolution is needed (12-bits or more). Contact your Acromag representative for information on our many isolated signal conditioning products that could be used to interface to the IP input/output modules.

3.0 PROGRAMMING INFORMATION

This Section provides the specific information necessary to program and operate the APC8620/8621 non-intelligent carrier board.

This Acromag APC8620/8621 is a PCI Specification version 2.1 compliant PCI bus slave carrier board. The carrier connects a PCI host bus to the IP module's 16-bit data bus per the Industrial I/O Pack logic interface specification on the mezzanine (IP) boards which are installed on the carrier.

The PCI bus is defined to address three distinct address spaces: I/O, memory, and configuration space. **The IP modules can be accessed via the PCI bus memory space only.**

The PCI card's configuration registers are initialized by system software at power-up to configure the card. The PCI carrier is a Plug-and-Play PCI card. As a Plug-and-Play card the board's base address and system interrupt request line are not selected via jumpers but are assigned by system software upon power-up via the configuration registers. A PCI bus configuration access is used to access a PCI card's configuration registers.

PCI Configuration Address Space

When the computer is first powered-up, the computer's system configuration software scans the PCI bus to determine

what PCI devices are present. The software also determines the configuration requirements of the PCI card.

The system software accesses the configuration registers to determine how many blocks of memory space the carrier requires. It then programs the carrier's configuration registers with the unique memory address range assigned.

The configuration registers are also used to indicate that the PCI carrier requires an interrupt request line. The system software then programs the configuration registers with the interrupt request line assigned to the PCI carrier.

Since this PCI carrier is relocatable and not hardwired in address space, this carrier's device drive provided by Acromag uses the mapping information stored in the carrier's Configuration Space registers to determine where the carrier is mapped in memory space and which interrupt line will be used.

Configuration Transactions

The PCI bus is designed to recognize certain I/O accesses initiated by the host processor as a configuration access. Configuration uses two 32-bit I/O ports located at addresses 0CF8 and 0CFC hex. These two ports are:

- 32-bit configuration address port, occupying I/O addresses 0CF8 through 0CFB hex.
- 32-bit configuration data port, occupying I/O addresses 0CFC through 0CFF hex.

Configuration space is accessed by writing a 32-bit long-word into the configuration address port that specifies the PCI bus, the carrier board on the bus, and the configuration register on the carrier being accessed. A read or write to the configuration data port will then cause the configuration address value to be translated to the requested configuration cycle on the PCI bus. Accesses to the configuration data port determine the size of the access to the configuration register addressed and can be an 8, 16, or 32-bit operation.

Any access to the Configuration address port that is not a 32-bit access is treated like a normal computer I/O access. Thus, computer I/O devices using 8 or 16-bit registers are not affected because they will be accessed as expected.

Table 3.1: Configuration Address Port

BIT	FUNCTION
31	Enables accesses to Configuration Data to be translated to configuration cycles on the PCI bus.
30-24	Reserved, Return 0 when read.
23-16	Bus Number Choose a specific PCI bus in the system. Zero if only one PCI bus.
15-11	Device Number Choose a specific device/PCI board on the bus.
10-8	Function Number Choose a specific function in a device. Function number is zero for the APC8620/8621
7-2	Register Number Used to indicate which PCI Configuration Register to access. The Configuration Registers and their corresponding register numbers are given in Table 3.2.
1-0	Read Only bits that return 0.

Configuration Registers

The PCI specification requires software driven initialization and configuration via the Configuration Address space. This PCI carrier provides 256 bytes of configuration registers for this purpose. The PCI carrier contains the configuration registers, shown in Table 3.2, to facilitate Plug-and-Play compatibility.

The Configuration Registers are accessed via the Configuration Address and Data Ports. The most important Configuration Registers are the Base Address Registers and the Interrupt Line Register which must be read to determine the base address assigned to the carrier and the interrupt request line that goes active on a carrier interrupt request.

Table 3.2 Configuration Registers

Reg. Num.	D31 D24	D23 D16	D15 D8	D7 D0
0	Device ID=1024		Vendor ID= 10B5	
1	Status		Command	
2	Class Code			Rev ID
3	BIST	Header	Latency	Cache
4	Base Addr. Memory Mapped Configuration Registers			
5	Base Address for I/O Mapped Configuration Registers			
6	32-bit Memory Base Address for APC8620/8621			
7 : 10	Not Used			
11	Subsystem ID		Subsystem Vendor ID	
12	Not Used			
13	Reserved			
14	Reserved			
15	Max_Lat	Min_Gnt	Inter. Pin	Inter. Line

MEMORY MAP

The 1K byte of memory consumed by the board is composed of blocks of memory for the ID, I/O and INT spaces corresponding to five IP modules. In addition, a small portion of the 1K byte address space contains registers specific to the function of the carrier board.

The carrier is configured to map this 1K byte block of memory into 32-bit memory space. The system configuration software will allocate space by writing the assigned address into the corresponding Base Address register of the Configuration Registers. The memory map for APC8620/8621 is shown in Tables 3.3.

Table 3.3: APC8620/8621 Carrier Bd Memory Map

Base Address + (Hex)	High Byte D15 D08	Low Byte D07 D00	Base Address + (Hex)
0001	Bit-8 Software Reset	Carrier Board Status/Control	0000
0003	IP Interrupt Pending Register		0002
0005	IP A Interrupt 0 Select Space		0004
0007	IP A Interrupt 1 Select Space		0006
0009	IP B Interrupt 0 Select Space		0008
000B	IP B Interrupt 1 Select Space		000A
000D	IP C Interrupt 0 Select Space		000C
000F	IP C Interrupt 1 Select Space		000E
0011	IP D Interrupt 0 Select Space		0010
0013	IP D Interrupt 1 Select Space		0012
0015	IP E Interrupt 0 Select Space		0014
0017	IP E Interrupt 1 Select Space		0016

Base Address + (Hex)	High Byte D15 D08	Low Byte D07 D00	Base Address + (Hex)
0019 ↓ 003F	Not Used	Not Used	0018 ↓ 003E
0041 ↓ 007F	IP A ID Space	IP A ID Space	0040 ↓ 007E
0081 ↓ 00BF	IP B ID Space	IP B ID Space	0080 ↓ 00BE
00C1 ↓ 00FF	IP C ID Space	IP C ID Space	00C0 ↓ 00FE
0101 ↓ 013F	IP D ID Space	IP D ID Space	0100 ↓ 013E
0141 ↓ 017F	IP E ID Space	IP E ID Space	0140 ↓ 017E
0181 ↓ 01FF	IP A I/O Space	IP A I/O Space	0180 ↓ 01FE
0201 ↓ 027F	IP B I/O Space	IP B I/O Space	0200 ↓ 027E
0281 ↓ 02FF	IP C I/O Space	IP C I/O Space	0280 ↓ 02FE
0301 ↓ 037F	IP D I/O Space	IP D I/O Space	0300 ↓ 037E
0381 ↓ 03FF	IP E I/O Space	IP E I/O Space	0380 ↓ 03FE

Note: Shaded areas not used by ACP8621 carrier.

The APC8620/8621 base address is determined through the PCI Configuration Registers. The addresses given in Table 3.3 are relative to the base address of the APC8620/8621 carrier. The addresses within each IP's own space are specific to that IP module. Refer to the IP module's User Manual for information relating to the IP specific addressing.

The Carrier registers, IP Identification (ID) spaces, IP Input/Output (IO), and IP Interrupt spaces are accessible via the PCI bus space as given in Tables 3.3. A 32-bit PCI bus access will result in two 16-bit accesses to the IP module. A 16-bit or 8-bit PCI bus access results in a single 16-bit or 8-bit access to the IP module respectively.

Carrier Status/Control Register - (Read/Write, Base + 00H)

The Carrier Board Status Register reflects and controls functions globally on the carrier board.

BIT	FUNCTION
15-09	Not Used
08 Write Only	Software Reset Writing a "1" to this bit causes a software reset. Writing a "0" or reading this bit has no effect. When set, the software reset pulse will have a duration of 1u second.
07-06	Not Used
05 Read And Write	IP Module Access Time Out Interrupt Pending This bit will be "1" when there is a IP Module Access Time Out interrupt pending. This bit will be "0" when there is no interrupt pending. Reset condition: Set to "0". Writing a "1" to this bit will release the pending interrupt.
04 Read Only	IP Module Access Time Out Status Status bit to indicated that the last IP module access has timed out. This bit only reflects the last IP module access. "0" if last IP module access did not time out. "1" if last IP module access did time out.
03 Read And Write	Time Out Interrupt Enable When set to "1", this bit will enable the carrier board to generate an interrupt upon time out of an IP module access. The default setting or reset condition is "0" (interrupt generation upon time out disabled). The interrupt service routine, in responding to the Time Out Access interrupt, will need to set this bit to 0 to clear the pending interrupt request.
02 Read And Write	IP Module Interrupt Enable When set to "1", this bit will enable the generation of IP module interrupts. The default setting or reset condition is "0" (IP module interrupt generation disabled). Interrupts must also be supported and configured at the IPs.
01 Read Only	IP Module Interrupt Pending This bit will be "1" when there is an interrupt pending. This bit will be "0" when there is no interrupt pending. Polling this bit will reflect the IP Module's pending interrupt status, even if the IP Module Interrupt Enable bit is set to "0". Reset condition: Set to "0".
00 Read Only	IP Module Error This bit will be "1" when there is an active IP Module Error signal. This bit will be "0" when all IP module Error signals are inactive. This bit allows the user to monitor the Error signals of IP modules A through E (A through C for APC8621). The Industrial I/O Pack specification states that the error signals indicate a non-recoverable error from the IP (such as a component failure or hard-wired configuration error). Refer to your IP specific documentation to see if the error signal is supported and what it indicates. Reset condition: Set to "0".

IP Interrupt Pending Register - (Read, Base + 02H)

The IP Interrupt Pending Register is used to individually identify pending IP interrupts or a pending carrier generated interrupt as a result of IP module time out access. If multiple IP interrupts are pending, software must determine the order in which they are serviced.

MSB D7	D6	D5	D4	D3	D2	D1	LSB D0
IP D Int1 Pend	IP D Int0 Pend	IP C Int1 Pend	IP C Int0 Pend	IP B Int1 Pend	IP B Int0 Pend	IP A Int1 Pend	IP A Int0 Pend

MSB D15	D14	D13	D12	D11	D10	D9	LSB D8
Not Used					Time Out Interrupt Pend	IP E Int1 Pend	IP E Int0 Pend

Note: Shaded areas not used by ACP8621 carrier.

Where:

All Bits
IP Interrupt
Pending
(Read)

A bit will be a "1" when the corresponding interrupt is pending. A bit will be a "0" when its corresponding interrupt is not pending. Polling this bit will reflect the IP module's pending interrupt status, even if the IP interrupt enable bit is set to "0". Reset Condition: Set to "0". An IP module pending interrupt bit will be cleared if its correspond interrupt request signal is inactive.

IP Module Interrupt Space - (Read Only)

The Interrupt space for each IP module is fixed at two 16-bit words. Interrupt 0 select space is read, typically by an interrupt service routine, to respond to an interrupt request via the IP Module's INTREQ0* signal. Likewise interrupt 1 select space is read to respond to an interrupt request via the IP Module's INTREQ1* signal. An access to an interrupt select space results in the IP module serving up an interrupt vector. In addition, access to the interrupt space will cause some IP modules to release their interrupt request. See each IP module's User Manual for details.

IP Module ID Space- (Read Only)

Each IP contains identification (ID) information that resides in the ID space per the IP specification. This area of memory contains either 32 bytes (Format I ID) or 64 bytes (Format II ID) of information, at most. Format I requires read of only the least significant byte. Format II requires read of a 16-bit value. The carrier will implement 16-bit reads to the ID space to allow support for either Format I or Format II. Both fixed and variable information may be present within the ID ROM. Variable information may include unique information required for the module. The identification Section for each IP module is located in the carrier board memory map per Table 3.3. Refer to the documentation of your IP module for specific information about each IP module's ID Space contents.

IP Module I/O Space - (Read/Write Only, 256-Byte Addresses)

The I/O space on each IP module is fixed at 128, 16-bit words (256 bytes). The five (three for APC8621) IP module I/O spaces are accessible at fixed offsets for the APC8620/8621's Base Address. IP modules may not fully decode their I/O space and may use byte or word only accesses. See each IP module's User Manual for details.

GENERATING INTERRUPTS

Interrupt requests originate from the carrier board in the case of an access time out and from the IP modules. Each IP may support 0, 1, or 2 interrupt requests. Upon an IP module interrupt request the carrier passes the interrupt request onto the host, provided that the carrier board is enabled for interrupts within the Carrier Board Status Register.

Sequence of Events For an Interrupt

1. Clear the interrupt enable bits in the Carrier Board Status Register by writing a "0" to bit 2/bit 3.
2. Write interrupt vector to the location specified on the IP and perform any other IP specific configuration required - do for each supported IP interrupt request.
3. Determine the IRQ line assigned to the carrier during system configuration (within the configuration register).
4. Set up the PC/AT's interrupt vector for the appropriate interrupt.
5. Unmask the IRQ on the PC/AT's 8259 interrupt controller.
6. The IP asserts an interrupt request to the carrier board (asserts interrupt request line IntReq0* or IntReq1*).
7. The carrier drives PCI bus interrupt request signal INTA# active.
8. PC/AT's drives the IRQ line assigned to the active carrier.
9. The interrupt service routine pointed to by the vector set up in step 4 starts.
10. Interrupt service routine determines which IP module caused the interrupt by reading the carrier interrupt pending register. If multiple interrupts are pending the interrupt service routine software determines which IP module to service first. In a PC interrupts are shared and can be from any slot on the backplane or from the mother board itself. The driver must first check that the interrupt came from the PCI carrier by reading the carrier interrupt pending register.
11. The interrupt service routine accesses the interrupt space of the IP module selected to be serviced. Note that the interrupt space accessed must correspond to the interrupt request signal driven by the IP module.
12. The carrier board will assert the INTSEL* signal to the appropriate IP together with (carrier board generated) address bit A1 to select which interrupt request is being processed (A1 low corresponds to INTREQ0*; A1 high corresponds to INTREQ1*).
13. The IP module receives an active INTSEL* signal from the carrier and supplies its interrupt vector to the host system during this interrupt acknowledge cycle. An IP module designed to release its interrupt request on acknowledge will release its interrupt request upon receiving an active INTSEL* signal from the carrier. If the IP module is designed to release its interrupt request on register access the interrupt service routine must access the required register to clear the interrupt request.
14. Write "End-Of-Interrupt" command to PC/AT's 8259.
15. If the IP interrupt stimulus has been removed and no other IP modules have interrupts pending, the interrupt cycle is completed (i.e. the carrier board negates its interrupt request INTA#).

4.0 THEORY OF OPERATION

This section describes the basic functionality of the circuitry used on the carrier board. Refer to the Block Diagram shown in the Drawing 4501-673 as you review this material.

CARRIER BOARD OVERVIEW

The carrier board is a PCI bus slave/target board providing up to five (three for APC8621) industry standard IP module interfaces. The carrier board's PCI bus interface allows an intelligent single board computer (PCI bus Master) to control and communicate with IP modules that are present on the PCI bus carrier. IP module field I/O connections link to the field I/O connections of the carrier which in turn are used to connect field electronic hardware to the carrier board via ribbon cable.

The PCI bus and IP module logic commons have a direct electrical connection (i.e., they are not electrically isolated). However, the field I/O connections can be isolated from the PCI bus if an IP module that provides this isolation (between the logic and field side) is utilized. A wide variety of IP modules are currently available (from Acromag and other vendors) that allow interface to many external devices for digital I/O, analog I/O, and communication applications.

PCI Bus Interface

The carrier board's PCI bus interface is used to program and monitor carrier board registers for configuration and control of the board's documented modes of operation (see section 3). In addition, the PCI bus interface is also used to communicate with and control external devices that are connected to an IP module's field I/O signals (assuming an IP module is present on the carrier board).

The PCI bus interface is implemented in the logic of the carrier board's PCI bus target interface chip. The PCI bus interface chip implements PCI specification version 2.1 as an interrupting slave including 8-bit and 16-bit data transfers to the IP modules.

The carrier board's PCI bus data transfer rates are shown in Table 2.3.

Carrier Board Registers

The carrier board registers (presented in section 3) are implemented in the logic of the carrier board's FPGA. An outline of the functions provided by the carrier board registers includes:

- Monitoring the error signal received from each IP module is possible via the **IP Error Bit**.
- Enabling of PCI bus interrupt requests from each IP module is possible via the **IP Module Interrupt Enable Bit**.
- Enabling of interrupt generation upon an IP module access time out is implemented via the **Time Out Interrupt Enable Bit**.
- Monitoring an IP module access time out is possible via the **IP Module Access Time Out Status Bit**.
- Identify pending interrupts via the carrier's **IP Module Interrupt Pending Bit**.
- Lastly, pending interrupts can be individually monitored via the **IP Module Interrupt Pending register**.

IP Logic Interface

The IP logic interface is also implemented in the logic of the carrier board's FPGA. The carrier board implements ANSI/VITA 4 1995 Industrial I/O Pack logic interface specification and includes five (three for APC8621) IP logic interfaces. The PCI bus address and data lines are linked to the address and data of the IP logic interface. This link is implemented and controlled by the carrier board's FPGA.

The PCI bus to IP logic interface link allows a PCI bus master to:

- Access up to 64 ID Space bytes for IP module identification via 8-bit or 16-bit data transfers using PCI bus.
- Access up to 128 I/O Space bytes of IP data via 8-bit or 16-bit data transfers.
- Access IP module interrupt space via 8-bit or 16-bit PCI bus data transfers.
- Respond to two IP module interrupt requests per IP module.

Carrier Board Clock Circuitry

A 16MHz clock is divided down by a clock driver to obtain the IP module 8MHz clock signals. Separate IP clocks are driven to each IP module. All clock lines include series damping resistors to reduce clock overshoot and undershoot.

When an IP module places data on the bus, for all data read cycles, any undriven data lines are read by the PCI bus as high because of pull-up resistors on the carrier board's data bus.

PCI Interrupter

Interrupts are initiated from an interrupting IP module. However, the carrier board will only pass an interrupt generated by an IP module to the PCI bus if the carrier board has been first enabled for interrupts. Each IP module can initiate two interrupts which can be individually monitored on the carrier board. After interrupts are enabled on the carrier board via the Interrupt Enable Bits (see section 3 for programming details), an IP generated interrupt is recognized by the carrier board and is recorded in the carrier board's Interrupt Pending Register.

A carrier board pending interrupt will cause the board to pass the interrupt to the PCI bus provided the Interrupt Enable bits of the carrier's Status Register have been enabled (see section 3 for programming details). The PC interrupt request line assigned by the system configuration software will then be asserted. The PC/AT will respond to the asserted interrupt line by executing the interrupt service routine corresponding to the interrupt line asserted. The interrupt service routine is executed only if the IRQ on the PC/AT's 8259 interrupt controller has been previously unmasked (see section 3 for programming details).

The interrupt service routine should respond to an interrupt by accessing IP Interrupt Select (INTSEL*) space. The interrupt service routine should also conclude the interrupt routine by writing the "End-Of-Interrupt" command to the PC/AT's 8259 interrupt controller (see section 3 for more details).

Power Failure Monitor

The carrier board contains a 5 volts undervoltage monitoring circuit which provides a reset to the IP modules when the 5 volt power drops below 4.27 volts typical / 4.15 volts minimum. This circuitry is implemented per the Industrial I/O Pack specification.

Power Supply Fuses

The +5V, supply lines to each of the IP modules are individually fused with a current limit of 2 amp imposed by the fuses. In addition, the +12, and -12 supply lines to each of the IP modules are individually fused with a current limit of 1 amp imposed by the fuses. A blown fuse can be identified by visible inspection or by use of an ohm meter. The fuses are located under each IP slot near the "logic connectors" (see figure 4501-671 or 4501-676).

Power Supply Filters

Power line filters are dedicated to each IP module for filtering of the +5, +12, and -12 volt supplies. The power line filters are a "T" type filter circuit comprising ferrite bead inductors and a feed-through capacitor. The filters provide improved noise performance as is required on precision analog IP modules.

5.0 SERVICE AND REPAIR

SERVICE AND REPAIR ASSISTANCE

Surface-Mounted Technology (SMT) boards are generally difficult to repair. It is highly recommended that a non-functioning board be returned to Acromag for repair. The board can be damaged unless special SMT repair and service tools are used. Further, Acromag has automated test equipment that thoroughly checks the performance of each board. When a board is first produced and when any repair is made, it is tested, placed in a burn-in room at elevated temperature, and retested before shipment.

Please refer to Acromag's Service Policy Bulletin or contact Acromag for complete details on how to obtain parts and repair.

PRELIMINARY SERVICE PROCEDURE

Before beginning repair, be sure that all of the procedures in Section 2, Preparation For Use, have been followed. Also, refer to the documentation of your carrier board to verify that it is correctly configured. Verify that there are no blown fuses. Replacement of the carrier and/or IP with one that is known to work correctly is a good technique to isolate a faulty board.

CAUTION: POWER MUST BE TURNED OFF BEFORE REMOVING OR INSERTING BOARDS

Acromag's Applications Engineers can provide further technical assistance if required. When needed, complete repair services are also available from Acromag.

6.0 SPECIFICATIONS

PHYSICAL

Physical Configuration.....PCI 5V Card

Length (APC8620).....12.283 inches (312.0 mm)

Length (APC8621)..... 6.600 inches (167.64 mm)

Height.....4.200 inches (106.68 mm)

Board Thickness.....0.063 inches (1.60 mm)

Max Component Height.....0.380 inches (9.65 mm)

Max Component Height Under IP Modules.....0.180 inches (4.57 mm)

Connectors:

P1 (PCI Bus).....PCI Specification 2.1 5V brd card edge "finger" spacing

A-E (Carrier Field I/O).....50-pin Male Header with ejector latches.

A-C (Carrier Field I/O).....50-pin Male Header without ejector latches.

P4,5, 9, 12, 15 (IP Field I/O).....50-pin male plug header (P3, 6, 9 for APC8621) (AMP 173280-3 or equivalent).

P6, 7, 10, 13, 16 (IP Logic).....50-pin male plug header (AMP (P4, 7, 10 for APC8621) 173280-3 or equivalent).

Power:

Board power requirements are a function of the installed IP modules. This specification lists currents for the carrier board only. The carrier board provides +5V, +12V and -12V power to each IP from the PCI bus. Each IP module supply line is individually filtered and fused.

Fuses: +5 volts, 2 amp per slot
±12 volts, 1 amp per slot

The power failure monitor circuit provides a reset to IP modules when the 5 volt power drops below 4.27 volts typically / 4.15 volts minimum.

Currents specified are for the carrier board only for Models AP8620/8621, add the IP module currents for the total current required from each supply.

+5 Volts (±5%).....210mA, Typical
300mA, Maximum.

+12 Volts (±5%).....0mA (Not Used)

-12 Volts (±5%).....0mA (Not Used)

PCI BUS COMPLIANCE

Specification.....This device meets or exceeds all written PCI Local Bus specifications per revision 2.1 dated June 1995.

Data Transfer Bus.....Slave with 32-bit, 16-bit, and 8-bit data transfer operation. 32-bit read or write accesses are implemented as two 16 bit transfers to the IP modules.

PCI bus Write Cycle Time.....150nS Typical measured from falling edge of FRAME# to the falling edge of TRDY#.

PCI bus Read Cycle Time.....150nS Typical; The carrier issues a RETRY which frees the PCI bus while the read request is completed. The PCI bus will repeat the same read

request until it completes with the requested data.

Write Complete Time.....Time from FRAME# active until LRDYi# active. 650nS Typical carrier register 750nS Typical 8-bit and 16-bit IP module write (assuming 0 IP module wait states). 1250nS Typical 32-bit IP module write (assuming 0 IP module wait states).

Read Complete Time.....Time from FRAME# active until LRDYi# active. 500nS Typical carrier register 650nS Typical 8-bit and 16-bit IP module read (assuming 0 IP module wait states). 1100nS Typical 32-bit IP module read (assuming 0 IP module wait states).

Interrupts.....PClbus INTA# interrupt signal Up to two requests sourced from each IP mapped to INTA#. Interrupt vectors come from IP modules via access to IP module INT space.

32-bit Memory Space.....Upon power-up the system auto- configuration process (plug & play) maps the carriers base address (for a 1K byte block of memory) into the PCI bus 32-bit Memory Space.

INDUSTRIAL I/O PACK COMPLIANCE

Specification.....This device meets or exceeds all written Industrial I/O Pack specifications per ANSI/VITA 4 1995 for 8MHz operation, only. Supports Type I and Type II ID space formats.

Electrical/Mechanical Interface.....Carrier supports five single-size IP modules (A-E), or two double-size and one single size IP module. 32-bit IP modules are not supported.

Electrical/Mechanical Interface.....Carrier supports three single-size IP modules (A-C), or one double-size and one single size IP module. 32-bit IP modules are not supported.

I/O Space.....16-bit and 8-bit: Supports 128 byte values per IP module.

ID Space.....16 and 8-bit; Supports Type 1 32 bytes per IP (consecutive odd byte addresses). Also supports Type II 32 words per IP via D16 data transfers.

Memory Space.....Not Supported.

Interrupts.....Supports two interrupt requests per IP and interrupt acknowledge cycles via access to IP INT space.

ENVIRONMENTAL

Operating Temperature.....	0 to +70°C; -40 to +85°C (E Versions)
Relative Humidity.....	5-95% non-condensing
Storage Temperature.....	-55 to +100°C.
Non-Isolated.....	PCI bus and IP module logic commons have a direct electrical connection. As such, unless the IP module provides isolation between the logic and field side, the field I/O signals are not isolated from the PCI bus.
Radiated Field Immunity (RFI).....	Designed to comply with IEC1000-4-3 Level 3 (10V/m at frequencies 27MHz to 500MHz) and European Norm EN50082-1.
Electromagnetic Interference Immunity (EMI).....	No digital upset under the influence of EMI from switching solenoids, commutator motors, and drill motors.
Electrostatic Discharge Immunity (ESD).....	Complies with IEC1000-4-2 Level 1 (2KV direct contact discharge) at field input/output terminals and European Norm EN50082-1.
Surge Immunity.....	Complies with IEC1000-4-5, Level 2 (1KV) and European Norm EN50082-1 at field input/output terminals.
Electric Fast Transient Immunity EFT.....	Complies with IEC1000-4-4 Level 2 (1KV power terminals; 0.5KV at field input and output terminals) and European Norm EN50082-1.
Radiated Emissions.....	Meets or exceeds European Norm EN50081-1 for class A equipment.

APPENDIX**CABLE: MODEL 5025-550-x (Non-Shielded)
MODEL 5025-551-x (Shielded)**

Type: Flat Ribbon Cable, 50-wires (female connectors at both ends). The '-x' suffix designates the length in feet (12 feet maximum). Choose shielded or unshielded cable according to model number. The unshielded cable is recommended for digital I/O, while the shielded cable is recommended for optimum performance with precision analog I/O applications.

Application: Used to connect Model 5025-552 termination panel to carrier board 50-pin field connectors.

Length: Last field of part number designates length in feet (user-specified, 12 feet maximum). It is recommended that this length be kept to a minimum to reduce noise and power loss.

Cable: 50-wire flat ribbon cable, 28 gage. Non-Shielded cable model uses Acromag Part 2002-211 (3M Type C3365/50 or equivalent). Shielded cable model uses Acromag Part 2002-261 (3M Type 3476/50 or equivalent).

Headers (Both Ends): 50-pin female header with strain relief. *Header - Acromag Part 1004-512 (3M Type 3425-6600 or*

equivalent). Strain Relief - Acromag Part 1004-534 (3M Type 3448-3050 or equivalent).

Keying: Headers at both ends have polarizing key to prevent improper installation.

Schematic and Physical Attributes: For Non-Shielded cable model, see Drawing 4501-462. For Shielded cable model, see Drawing 4501-463.

Shipping Weight: 1.0 pound (0.5Kg), packed.

CABLE: MODEL 5029-943

Type: Model 5029-943 IP500 Communication Cable: A five foot long, flat 50-pin cable with a female connector on one end (for connection to carrier board) and four DE-9P connectors (serial ports) on the other end.

Application: Used to connect up to four DB-9 serial ports to carrier board connectors. It is used primarily with Acromag Model IP500, IP501, & IP502 serial communication modules.

Length: 5 feet.

Cable: 50-wire flat ribbon cable, 28 gage. Non-Shielded cable model uses Acromag Part 2002-211 (3M Type C3365/50 or equivalent).

Headers: 50-pin female header with strain relief. *Header - Acromag Part 1004-512 (3M Type 3425-6600 or equivalent). Strain Relief - Acromag Part 1004-534 (3M Type 3448-3050 or equivalent).*

Port Connectors: Four DE-9P (9-pin, D-SUB, Male) connectors with strain relief (3M connector U89809-9000 with 3448-8D09A strain relief, or equivalent).

Keying: 50-pin Header at one end has polarizing key to prevent improper installation.

Shipping Weight: 1.0 pound (0.5Kg) packaged.

TERMINATION PANEL: MODEL 5025-552

Type: Termination Panel For Carrier Boards

Application: To connect field I/O signals to the Industrial I/O Pack (IP). *Termination Panel: Acromag Part 4001-040 (Phoenix Contact Type FLKM 50).* The 5025-552 termination panel facilitates the connection of up to 50 field I/O signals and connects to the carrier boards via a flat ribbon cable (Model 5025-550-x or 5025-551-x). The field connectors on the carrier board connect the I/O signals to the P2 connector on each of the Industrial I/O Pack modules. Field signals are accessed via screw terminal strips. The terminal strip markings on the termination panel (1-50) correspond to P2 (pins 1-50) on the Industrial I/O Pack (IP). Each Industrial I/O Pack (IP) has its own unique P2 pin assignments. Refer to the IP module manual for correct wiring connections to the termination panel.

Schematic and Physical Attributes: See Drawing 4501-464.

Field Wiring: 50-position terminal blocks with screw clamps. Wire range 12 to 26 AWG.

Connections to Carrier: P1, 50-pin male header with strain relief ejectors. Use Acromag 5025-550-x or 5025-551-x cable to connect panel to carrier board. Keep cable as short as possible to reduce noise and power loss.

Mounting: Termination panel is snapped on the DIN mounting rail.

Printed Circuit Board: Military grade FR-4 epoxy glass circuit board, 0.063 inches thick.

Operating Temperature: -40°C to +100°C.

Storage Temperature: -40°C to +100°C.

Shipping Weight : 1.25 pounds (0.6kg) packed.

APC8620 IP LOCATIONS

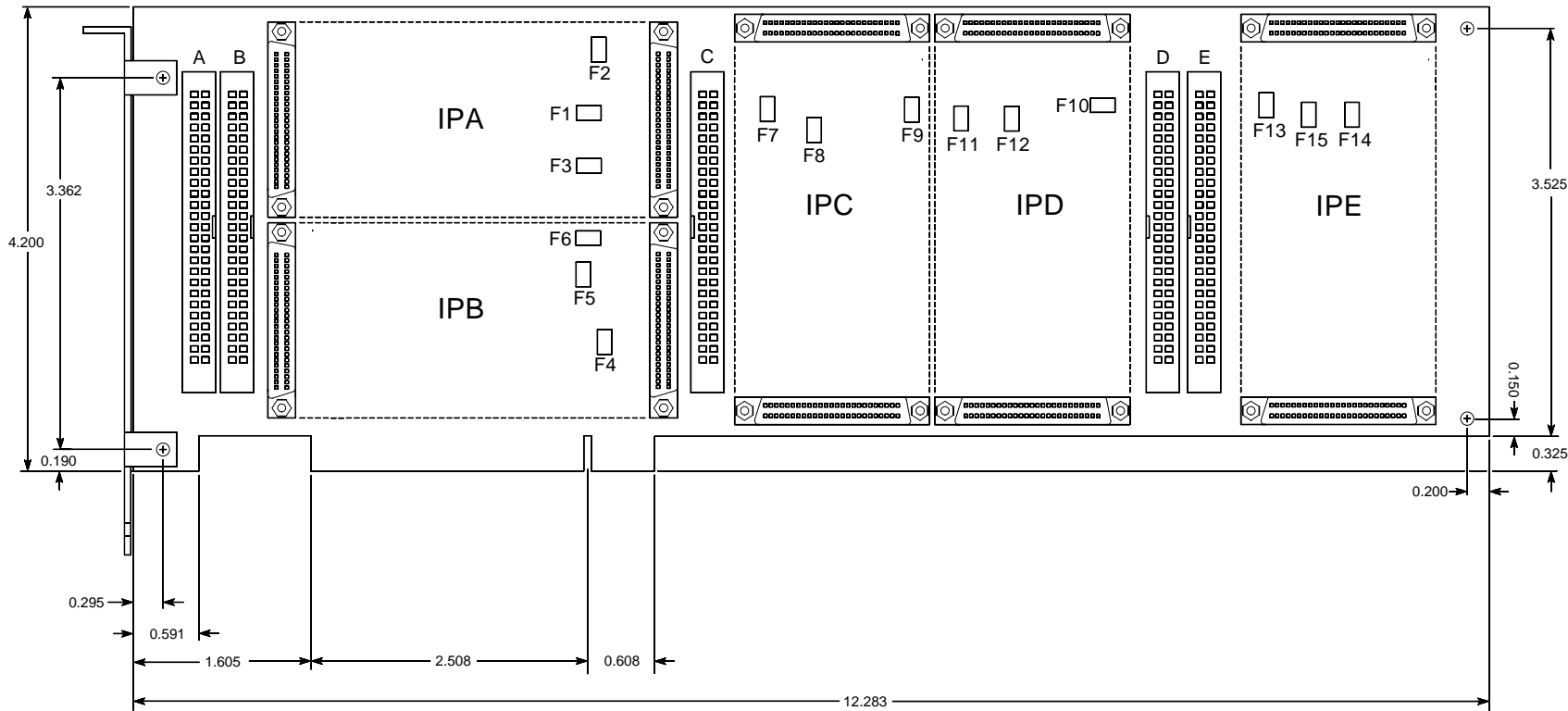

FUSES	
+5V(2 AMP)	F1, 6, 9, 10 & 13
+12V(1 AMP)	F2, 4, 7, 12 & 15
-12V(1 AMP)	F3, 5, 8, 11 & 14

4501-671B

APC8621 IP LOCATIONS

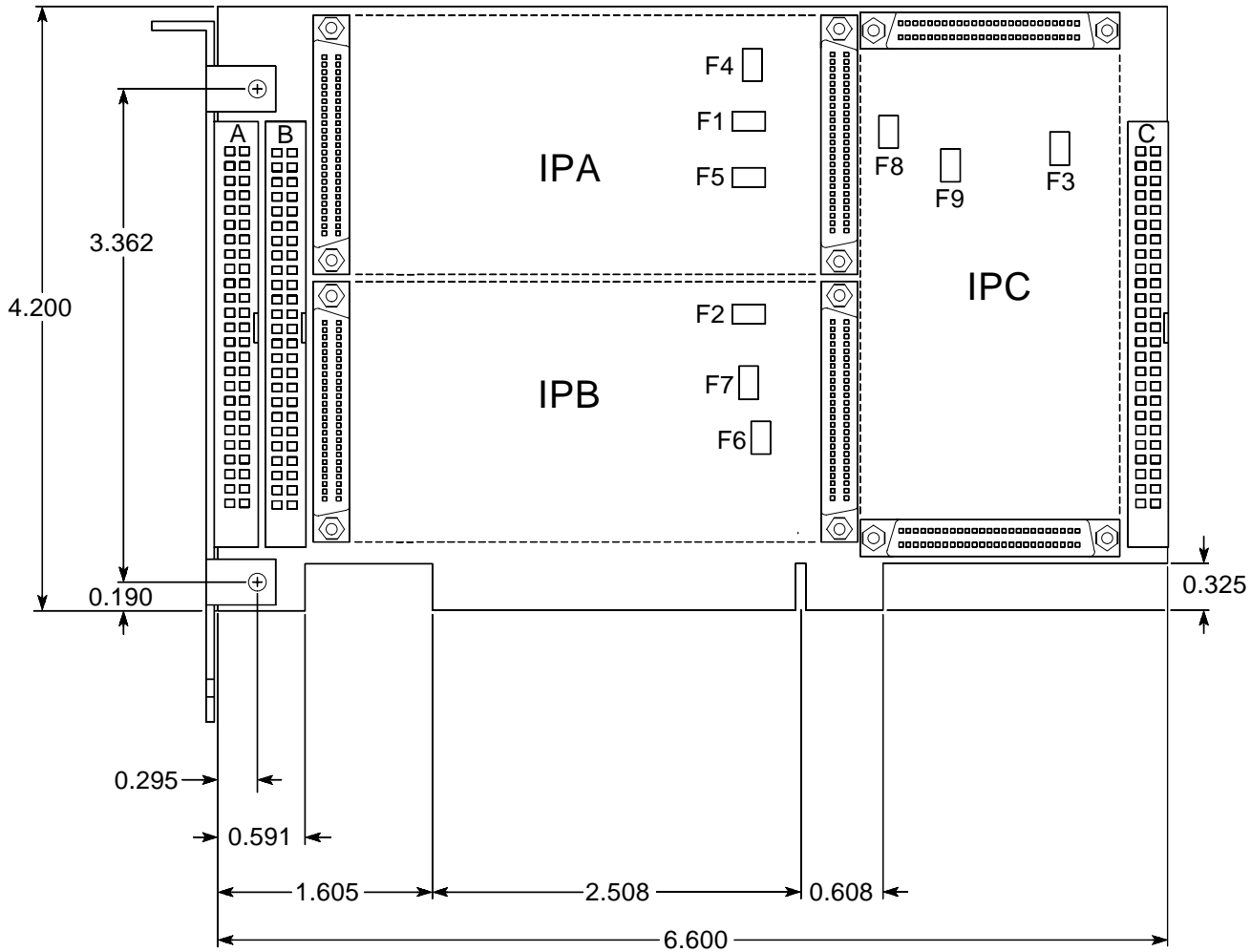

FUSES	
+5V(2 AMP)	F1, 2 & 3
+12V(1 AMP)	F4, 6 & 8
-12V(1 AMP)	F5, 7 & 9

4501-676A

IP MODULE TO CARRIER BOARD MECHANICAL ASSEMBLY

ASSEMBLY PROCEDURE:

1. THREADED SPACERS ARE PROVIDED BY ACROMAG IN TWO DIFFERENT LENGTHS WITH IP MODULES. THE SHORTER LENGTH IS FOR USE WITH APC8620 CARRIER BOARD (SHOWN).
2. INSERT FLAT HEAD SCREWS (ITEM A) THROUGH SOLDER SIDE OF IP MODULE AND INTO HEX SPACERS (ITEM B) AND TIGHTEN (4 PLACES) UNTIL HEX SPACER IS COMPLETELY SEATED.
3. CAREFULLY ALIGN IP MODULE TO CARRIER BOARD AND PRESS TOGETHER UNTIL CONNECTORS AND SPACERS ARE SEATED.
4. INSERT PAN HEAD SCREWS (ITEM C) THROUGH SOLDER SIDE OF CARRIER BOARD AND INTO HEX SPACERS (ITEM B) AND TIGHTEN (4 PLACES).

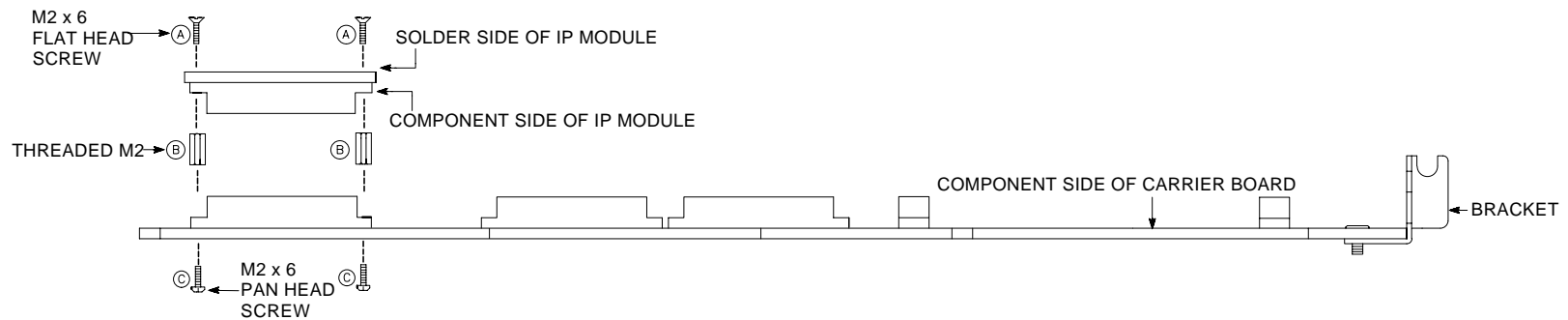

4501-672A

APC8620/8621 BLOCK DIAGRAM

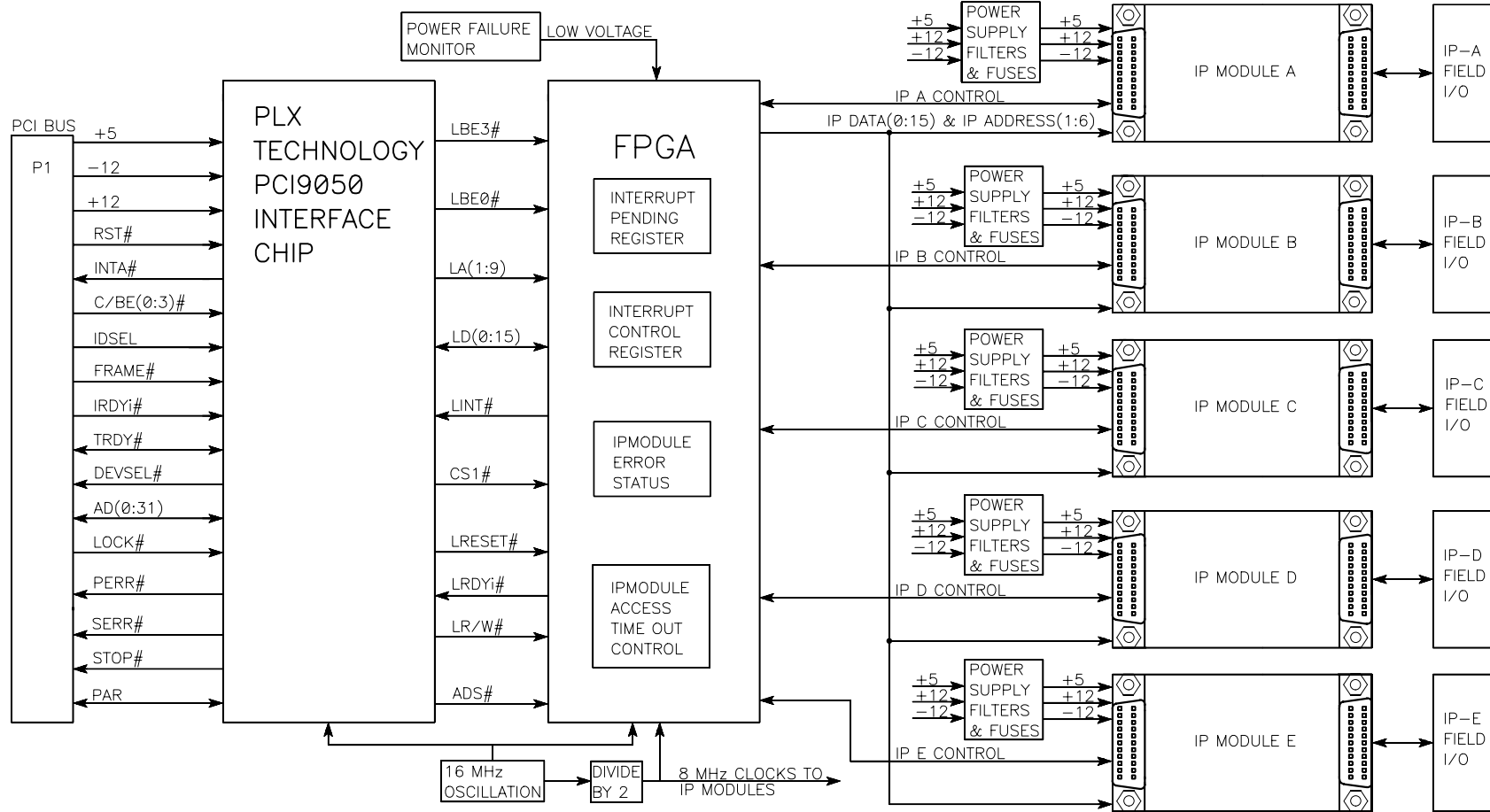

NOTE: FOR MODEL APC8621 IP MODULES D & E ARE NOT AVAILABLE.

4501-673B

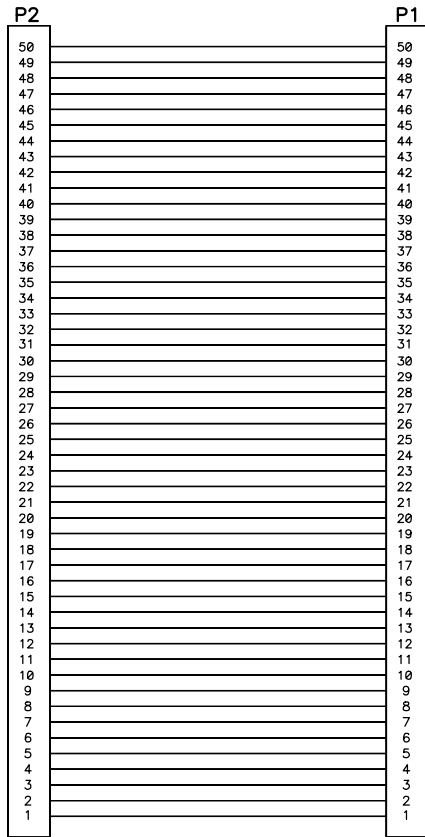

MODEL 5025-550-x SCHEMATIC

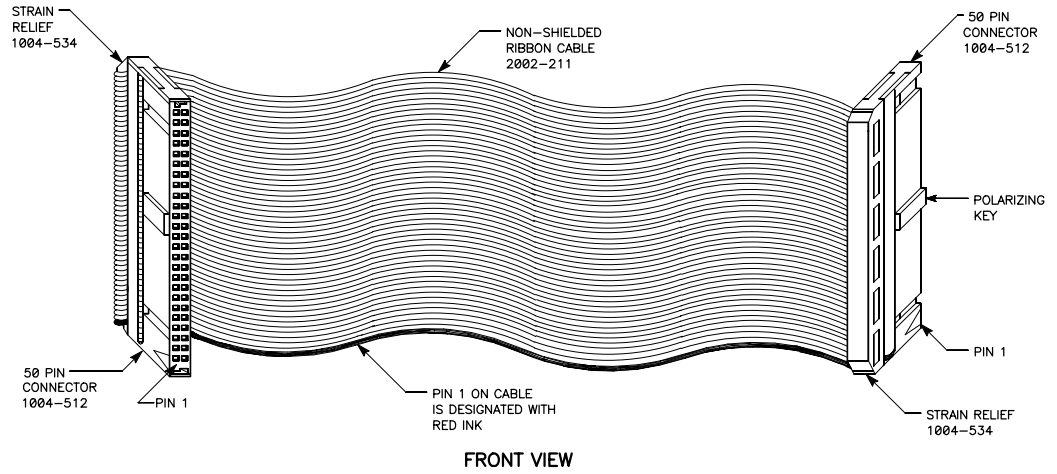
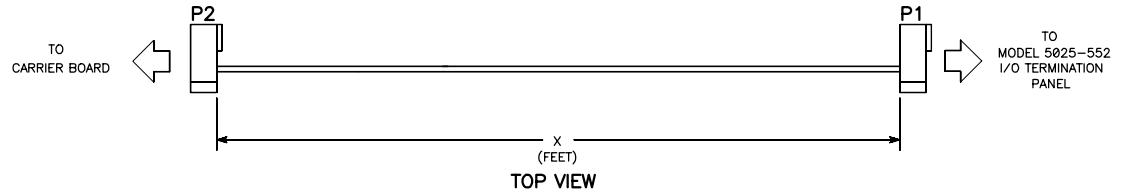

NOTE: SEVEN DIGIT PART NUMBERS ARE ACROMAG PART NUMBERS (XXXX-XXX).

MODEL 5025-550-x SIGNAL CABLE, NON-SHIELDED

4501-462A

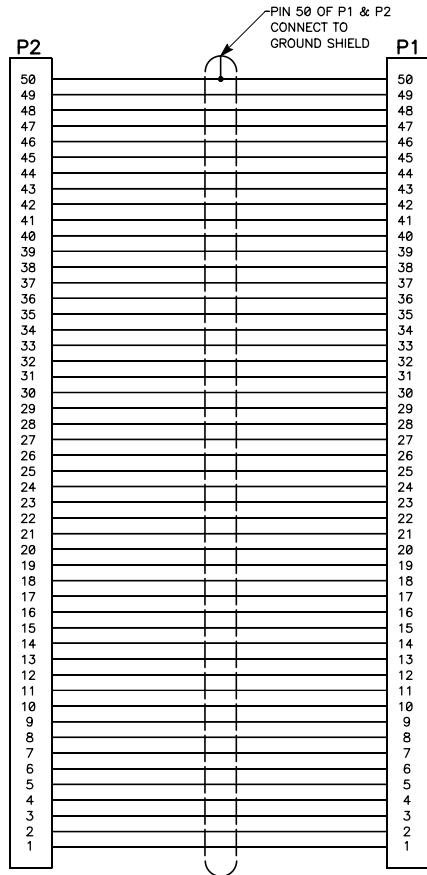

MODEL 5025-551-x SCHEMATIC

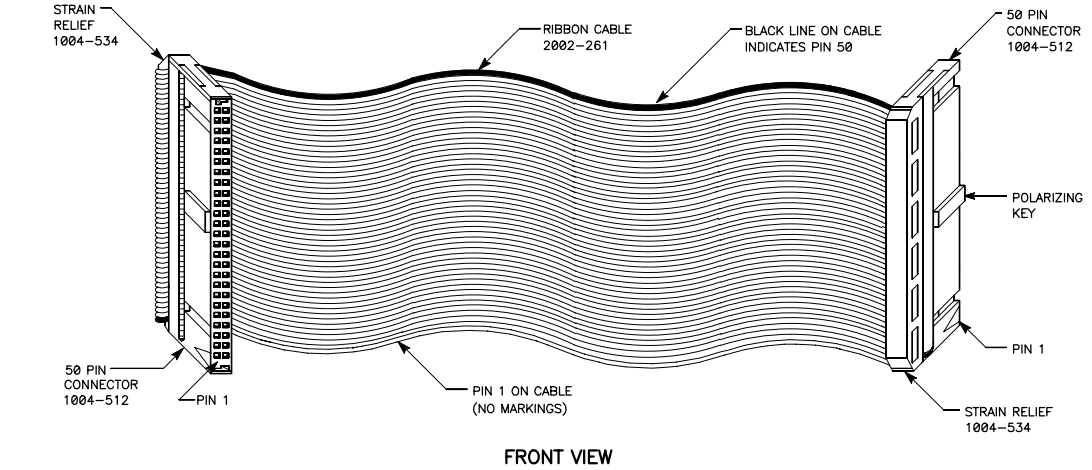
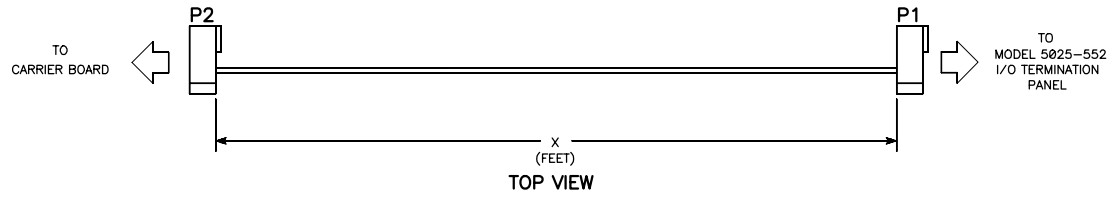

NOTE: SEVEN DIGIT PART NUMBERS ARE
ACROMAG PART NUMBERS (XXXX-XXX).

MODEL 5025-551-x SIGNAL CABLE, SHIELDED

4501-463A

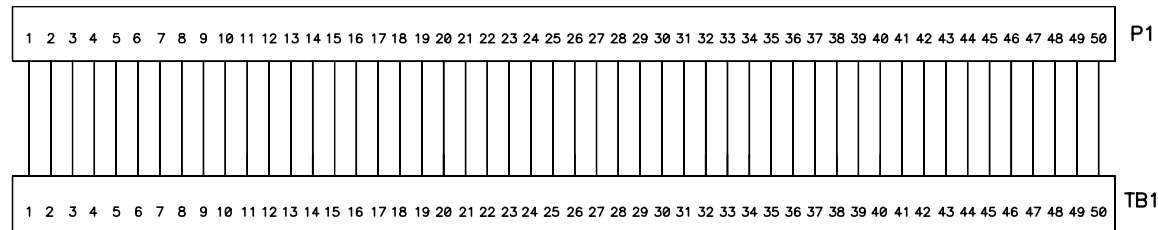

MODEL 5025-552 TERMINATION PANEL SCHEMATIC

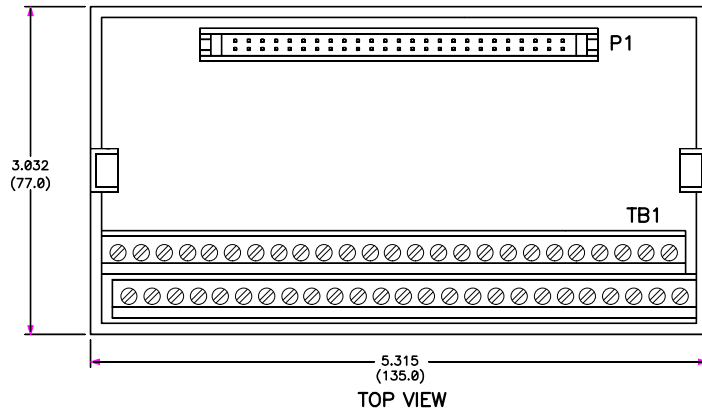

TOP VIEW

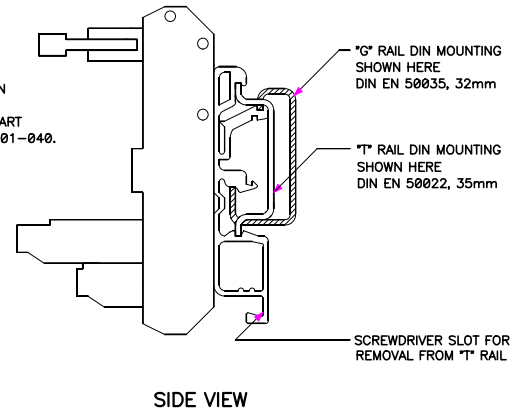

SIDE VIEW

NOTES:
DIMENSIONS ARE IN INCHES (MILLIMETERS).
TOLERANCE: ± 0.020 (± 0.5).

MODEL 5025-552 TERMINATION PANEL

4501-464A

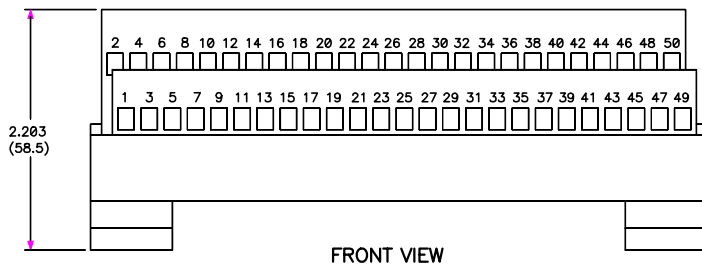

FRONT VIEW