



Black

White

CO29

FEATURES

PERFORMANCE

- 2.1 cubic feet overall refrigerator capacity maximizes storage of food and beverage items
- High output daily ice rate of up to 18 lbs and storage of up to 13 lbs of crescent ice (1/2" W x 3/4" H x 2-1/2" L)
- Temperature setting from 34 to 45° F provides flexibility for preserving a wide variety of items
- No drain required makes it easy and inexpensive to install and requires only a 1/4" outside diameter water line
- Conserves energy by using less electricity than a 75-watt light bulb
- Uses under 3 gallons of water to produce 25 lbs of ice
- Mechanical controlled passive cooling system
- Manual defrost maximizes ice making potential
- 220 volt model available with a 4 – 6 week order lead time

INTERIOR / EXTERIOR

- Vinyl coated cabinet helps withstand tough marine environments
- Corrosion and UV resistant marine grade hardware provide better product longevity in harsh environments
- Aluminum framed door with anodized durable aluminum handle weathers outdoor elements on white model

INTEGRATION

- Field reversible door with zero clearance door swing simplifies installation
- Black model will accept a 1/4" insert panel
- No additional clearance around sides, top or rear of unit is needed for ventilation
- Sleek and contemporary look provides a very clean, high-end aesthetic
- Do not obstruct front grille air flow
- For proper installation and cut-out dimensions, see backside for details

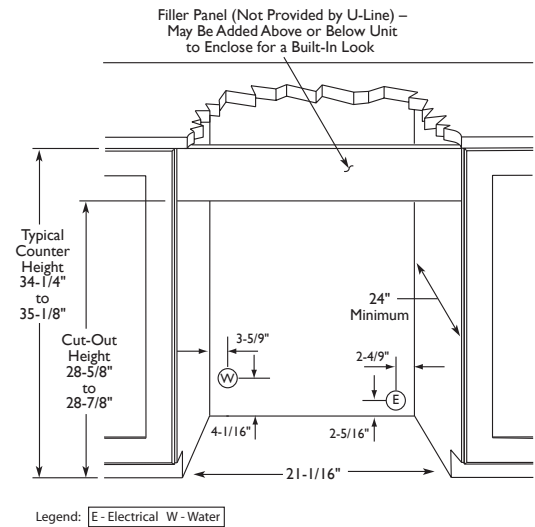
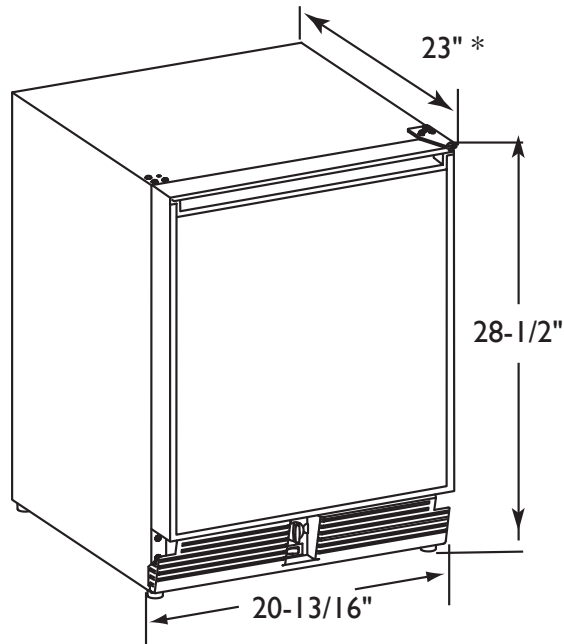

CO29B Black Model

* Add 15/16" to depth for water line clearance

DIMENSIONS AND SPECIFICATIONS

OVERALL DIMENSIONS

Height	28-1/2" (72.4)
Width	20-13/16" (52.9)
Depth	23" (58.4)
Shipping weight:	98 lbs (44 kg)
Running amps	2.5
Maximum start-up amps	18.0
Amps pertain to voltage rating	110/115 volt, 60 Hz
Optional in 220/230 voltage, 50/60 Hz	

Capacities:

Defrost technology	Manual defrost
Refrigerator volume	2.1 Cu. Ft
Approximate daily ice production	Up to 18 lbs
Ice Storage	Up to 13 lbs

CO29

Black 110V	U-CO29B-03
Black 220V	U-CO29BTP-20
White 110V	U-CO29WH-03
White 220V	U-CO29WHTP-20

Please visit www.u-line.com for installation guide.

All specifications are subject to change without notice.

