

ATS1000 Series Stage

User's Manual

P/N: EDS109 (Revision 1.03.00)



Dedicated to the Science of Motion
Aerotech, Inc.
101 Zeta Drive,
Pittsburgh, PA, 15238
Phone: 412-963-7470
Fax: 412-963-7459
www.aerotech.com



Product Registration

Register online at: <http://www.aerotech.com/prodreg.cfm>

Technical Support

United States Headquarters:

Phone: (412) 967-6440

Fax: (412) 967-6870

Email: service@aerotech.com

United Kingdom:

Phone: +44 118 940 9400

Fax: +44 118 940 9401

Email: service@aerotech.co.uk

Germany:

Phone: +49 911 967 9370

Fax: +49 911 967 93720

Email: service@aerotechgmbh.de

Japan:

Phone: +81(0)47-489-1741 (Sales)

Phone: +81(0)47-489-1742 (Service)

Fax: +81(0)47-489-1743

Email: service@aerotechkk.com.jp

China:

Phone: +852-3793-3488

Email: saleschina@aerotech.com

Revision History

Revision 1.03.00	April 7, 2011
Revision 1.02.00	November 18, 2010
Revision 1.01.00	January 5, 2009
Revision 1.00.00	June 12, 2006

Table of Contents

Table of Contents.....	iii
List of Figures.....	v
List of Tables.....	vii
Chapter 1: Overview.....	1
1.1. Standard Features.....	2
1.1.1. Optional Features.....	3
1.1.2. Model Numbers.....	4
1.2. Dimensions.....	6
1.3. Safety Procedures and Warnings.....	9
1.4. EC Declaration of Incorporation.....	11
Chapter 2: Installation.....	13
2.1. Unpacking and Handling the Stage.....	13
2.2. Preparing the Mounting Surface.....	14
2.2.1. Securing the Stage to the Mounting Surface.....	15
2.2.2. Securing the Stage to the Mounting Surface (Hardcover).....	16
2.2.3. Securing the Stage to the Mounting Surface (Bellows).....	17
2.3. Attaching the Payload to the Stage.....	18
2.4. Electrical Installation.....	18
2.4.1. Standard Aerotech Motor options.....	18
2.4.2. Motor Foldback Options.....	19
2.4.3. Optical Limit Switches.....	20
Chapter 3: Operating Specifications.....	21
3.1. Environmental Specifications.....	21
3.2. Accuracy and Temperature Effects.....	21
3.3. Basic Specifications.....	22
3.4. Load Capability.....	25
3.5. Optical Limit Switch.....	28
3.5.1. Limit Switch Operation.....	28
3.5.2. Limit Switch Wiring.....	29
3.6. Standard Motor Wiring.....	30
3.7. Vacuum Operation.....	34
3.7.1. Special Guidelines.....	34
Chapter 4: Maintenance.....	35
4.1. Service and Inspection Schedule.....	35
4.2. Cleaning and Lubrication.....	36
4.2.1. Recommended Lubricants and Cleaning Solvents.....	36
4.2.2. Important Notes on Lubrication.....	36
4.3. Lubrication and Cleaning Process.....	37
4.4. Belt Adjustment (Foldback Motor Option).....	39
Appendix A: Warranty and Field Service.....	41
Appendix B: Technical Changes.....	43
Index.....	45
Reader's Comments.....	47

List of Figures

Figure 1-1:	Typical ATS1000-H Series Linear Positioning Stage With Hard Cover.....	1
Figure 1-2:	ATS1000 (Open Configuration) with View of Ballscrew.....	2
Figure 1-3:	Two (XZ) and Three (XYZ) Axis Positioning Systems using ATS1000 stages.....	3
Figure 1-4:	ATS1000 stage with Bellows Option.....	3
Figure 1-5:	ATS1000 Dimensions.....	6
Figure 1-6:	ATS1000-B Dimensions.....	7
Figure 1-7:	ATS1000-H Dimensions.....	8
Figure 2-1:	Results of Flat Versus Non-Flat Mounting.....	14
Figure 2-2:	Top view of an ATS1000 Stage Showing Mounting Holes.....	15
Figure 2-3:	Hardcover Removal.....	16
Figure 2-4:	Bellows Removal.....	17
Figure 2-5:	ATS1000 Stage NEMA 23 Motor Mounting Flange.....	19
Figure 2-6:	ATS1000 Stage Showing Limit Switch Connector.....	20
Figure 3-1:	Load Capability of ATS1000 Series Stages.....	25
Figure 3-2:	Stage Orientations for LVC and LSC.....	26
Figure 3-3:	Torque Required to Turn ATS1000 Ballscrew with Various Loads.....	27
Figure 3-4:	Internal View of a Typical Stage Showing Limit Switches.....	28
Figure 3-5:	ATS1000 Series 9-pin Limit Switch Wiring (Foldback Equipped Stages Only).....	29
Figure 3-6:	Normally Closed (NC) and Normally Open (NO) Limit Switch Wiring.....	29
Figure 3-7:	Limit, Brake, and Encoder Wiring for Standard ATS1000 Stages with Integral Motor.....	30
Figure 3-8:	Motor Wiring Connector for all ATS1000 Stages.....	31
Figure 3-9:	Brake and Encoder Connector for Stages with Foldback Option.....	32
Figure 4-1:	Hardcover Removal Procedure.....	38
Figure 4-2:	Bellows Removal Procedure.....	38
Figure 4-3:	Belt Access and Adjustment on Foldback Models.....	39

List of Tables

Table 1-1: Model Numbering System	4
Table 2-1: ATS1000 Motor Options.....	19
Table 3-1: Environmental Specifications.....	21
Table 3-2: ATS1000 Series Specifications.....	22
Table 3-3: ATS1000 Series Motor Specifications.....	24
Table 3-4: Motor Wiring Pinout Descriptions.....	33
Table B-1: Current Changes (1.03.00).....	43
Table B-2: Archived Changes.....	44

Chapter 1: Overview

This manual describes Aerotech's ATS1000 series of ballscrew positioning stages. Figure 1-1 shows a typical ATS1000 positioning stage.

The ATS1000 series stages have travel distances ranging from 100 to 600 mm. It provides a small cross-section, medium payload capacity, cost effective alternative for precision applications where a small footprint and environmental protection are required. This chapter introduces standard and optional features of the ATS1000 stages, explains the model numbering system, and gives general safety precautions.



Figure 1-1: Typical ATS1000-H Series Linear Positioning Stage With Hard Cover

NOTE: Aerotech continually improves its product offerings, and listed options may be superseded at any time. Refer to the most recent edition of the Aerotech Motion Control Product Guide for the most current product information at www.aerotech.com.

1.1. Standard Features

The 8 mm lead ballscrew and Linear Motion Guide (LMG) are standard features on all stages (see Figure 1-2). The precision-ground, preloaded ballscrew ensures superior positioning resolution and accuracy while the LMG bearing system provides stiffness, good load carrying capabilities, and continuous load support over the entire range of travel. Optical limit switches and mechanical end stops to protect the stage table from over-travel are also standard.

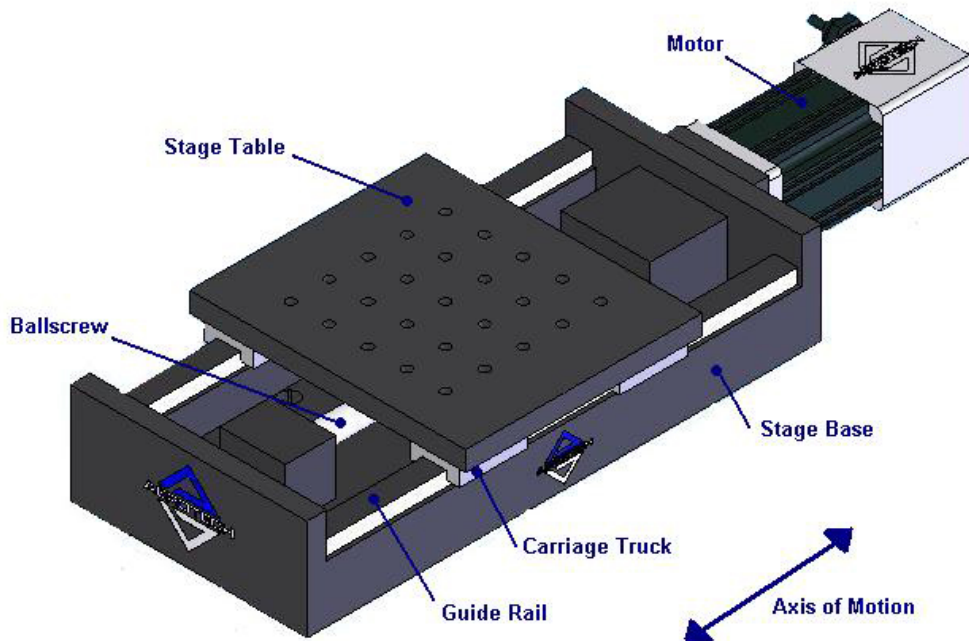

Figure 1-2: ATS1000 (Open Configuration) with View of Ballscrew

1.1.1. Optional Features

Available assembly options allow the ATS1000 series stages to be configured for a variety of applications. A foldback option is available for use in space-constrained applications. The stage travel limit switches can be configured to be either a normally closed or normally open depending on requirements.

An electric brake is available for ATS1000 stages. The 24VDC, spring-set motor brake is capable of holding the stage in position even when mounted vertically.

To help prevent contamination in dirty environments, air fittings are available to purge the stage with air. This will help prevent particles from entering the stage. In addition to the air-purge option, two waycover options exist: hard cover and bellows. A standard ATS1000 stage with the hard cover option was shown in Figure 1-1 while the bellows option is shown in Figure 1-4.

Various stage assembly options are available to create multiple axis motion systems. XY or YZ stage assemblies can be mounted together and aligned for 5 or 10 arc second orthogonality.

To increase accuracy of the stage, HALAR is available. The stage is factory calibrated for accuracy errors of the ballscrew and corrections are made in the software.

For vacuum applications, two vacuum preparation options are available upon request—one compatible with low vacuum environments (down to 10^{-3} torr) and the other for high vacuum (10^{-3} to 10^{-6} torr) applications. In addition, an electroless nickel finish option is also available.

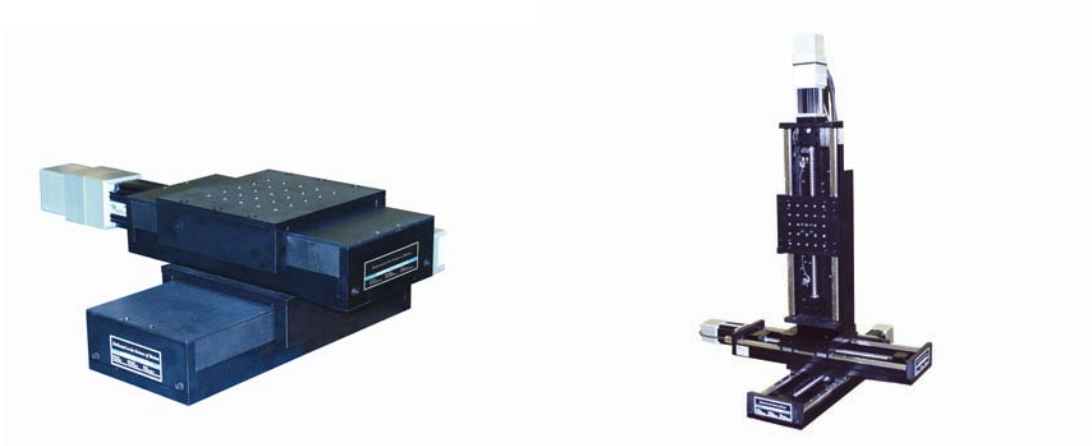

Figure 1-3: Two (XZ) and Three (XYZ) Axis Positioning Systems using ATS1000 stages



Figure 1-4: ATS1000 stage with Bellows Option

1.1.2. Model Numbers

Stage model number example: ATS10010-H-M-80P-NC-BMS-BRK23

The table below lists the available options in the order they appear in the example above. Aerotech continually improves its product offerings, and listed options may be superseded at any time. Refer to the most recent edition of the Aerotech Motion Control Product Guide for the most current product information at www.aerotech.com.

Table 1-1: Model Numbering System

Travel Options	
ATS10010	100 mm travel stage with ballscrew, bearings, and limits
ATS10015	150 mm travel stage with ballscrew, bearings, and limits
ATS10020 ⁽¹⁾	200 mm travel stage with ballscrew, bearings, and limits
ATS10030	300 mm travel stage with ballscrew, bearings, and limits
ATS10040	400 mm travel stage with ballscrew, bearings, and limits
ATS10045 ⁽²⁾	500 mm travel stage with ballscrew, bearings, and limits
ATS10050 ⁽¹⁾	500 mm travel stage with ballscrew, bearings, and limits
ATS10060	600 mm travel stage with ballscrew, bearings, and limits
Waycover Options	
-H	Hard Cover
-B	Full Bellows
Stage Construction Options	
-VAC3	Vacuum preparation of stage to 10^{-3} torr (no bellows and no side seals)
-VAC6	Vacuum preparation of stage to 10^{-6} torr (no bellows and no side seals)
-Nickel	Electroless nickel finish (consult factory)
Mounting and Grid Pattern	
-M	Metric dimension mounting pattern and holes
-U	English dimension mounting pattern and holes
Drive Screw	
-80P	8 mm/per rev precision-ground ball screw
Limits	
-NC	Normally closed end of travel limit switches (standard)
-NO	Normally open end of travel limit switches
Motor	
-BMS	Brushless servo motor with connectors and 2000-line encoder; requires cable (BMS60-A-D25-E2000H)
-DC	DC servo motor with connector and 2000-line encoder; requires cable (1050LT-MSOF-E2000LD)
-SM	Stepping motor with connector and home marker pules (one per rev); requires cable (101SMB2-HM)
-NM	No motor or encoder
Options	
-BRK23	24 VDC spring-set motor brake for NEMA 23 motor
-FB10	Foldback motor kit
-PO2	Air-purge pressure fittings

Table 1-1: Model Numbering System (continued)

Accessories (to be ordered as separate line item)	
ALIGNMENT-NPA	Non-precision XY assembly
ALIGNMENT-NPAZ	Non-precision XZ or YZ assembly
ALIGNMENT-PA10	XY assembly; 10 arc sec orthogonal
ALIGNMENT-PA10Z	XZ or YZ assembly with L-bracket; 10 arc second orthogonal
ALIGNMENT-PA5	XY assembly; 5 arc sec orthogonal
ALIGNMENT-PA5Z	XZ or YZ assembly with L-bracket; 5 arc second orthogonal
HDZ10M	Metric right-angle L-bracket
HALAR	High-accuracy system - linear error correction for accuracy and repeatability
(1) ATS1000-H only	
(2) ATS1000 and ATS1000-B only	

1.2. Dimensions

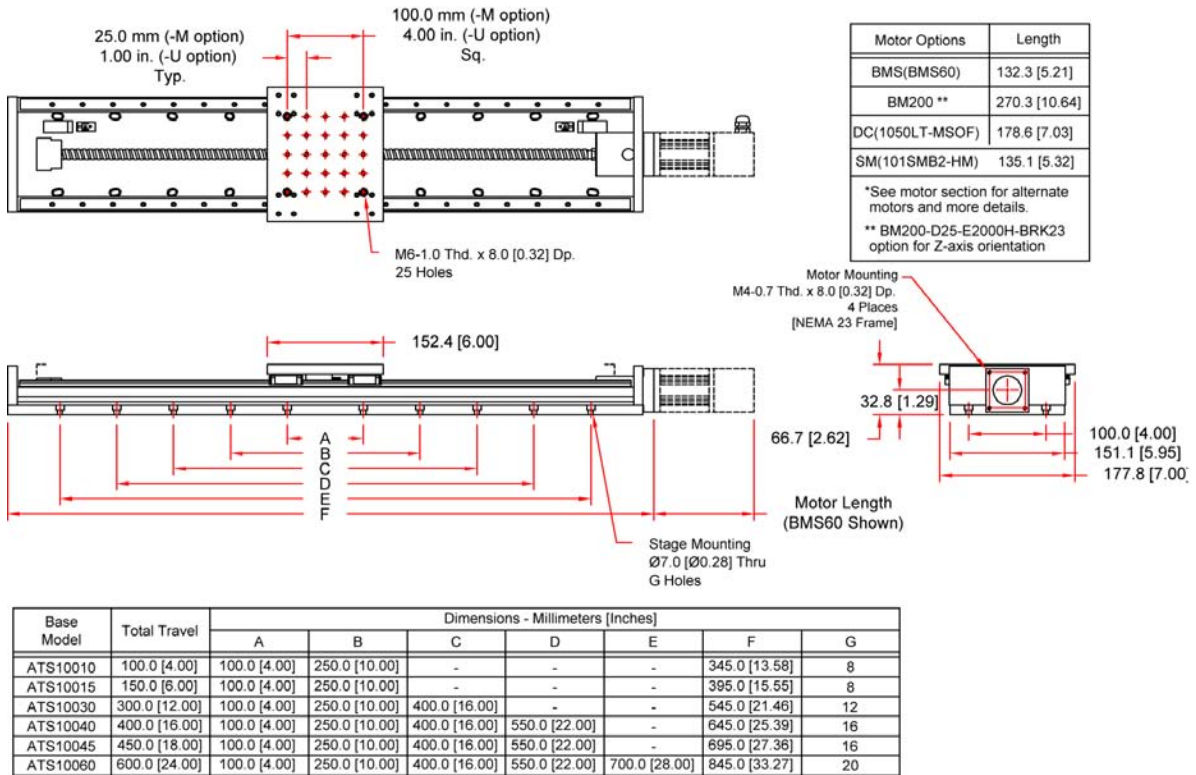

Figure 1-5: ATS1000 Dimensions

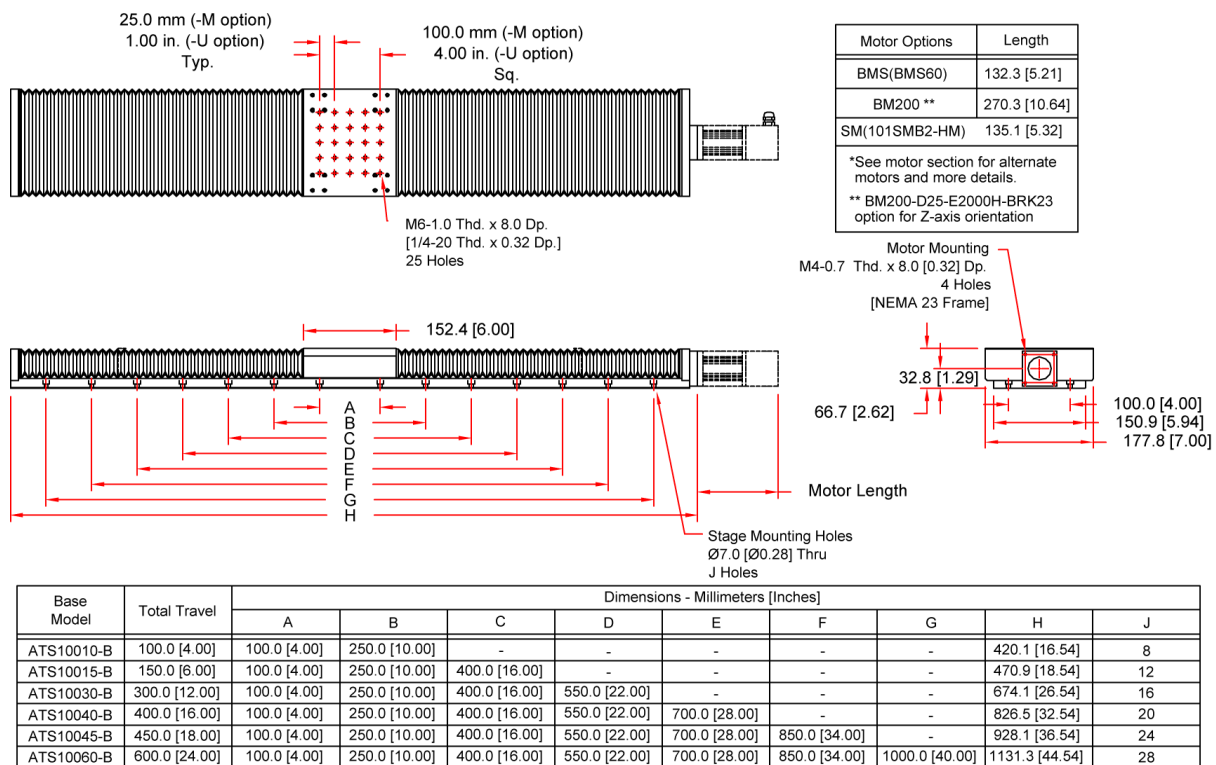

Figure 1-6: ATS1000-B Dimensions

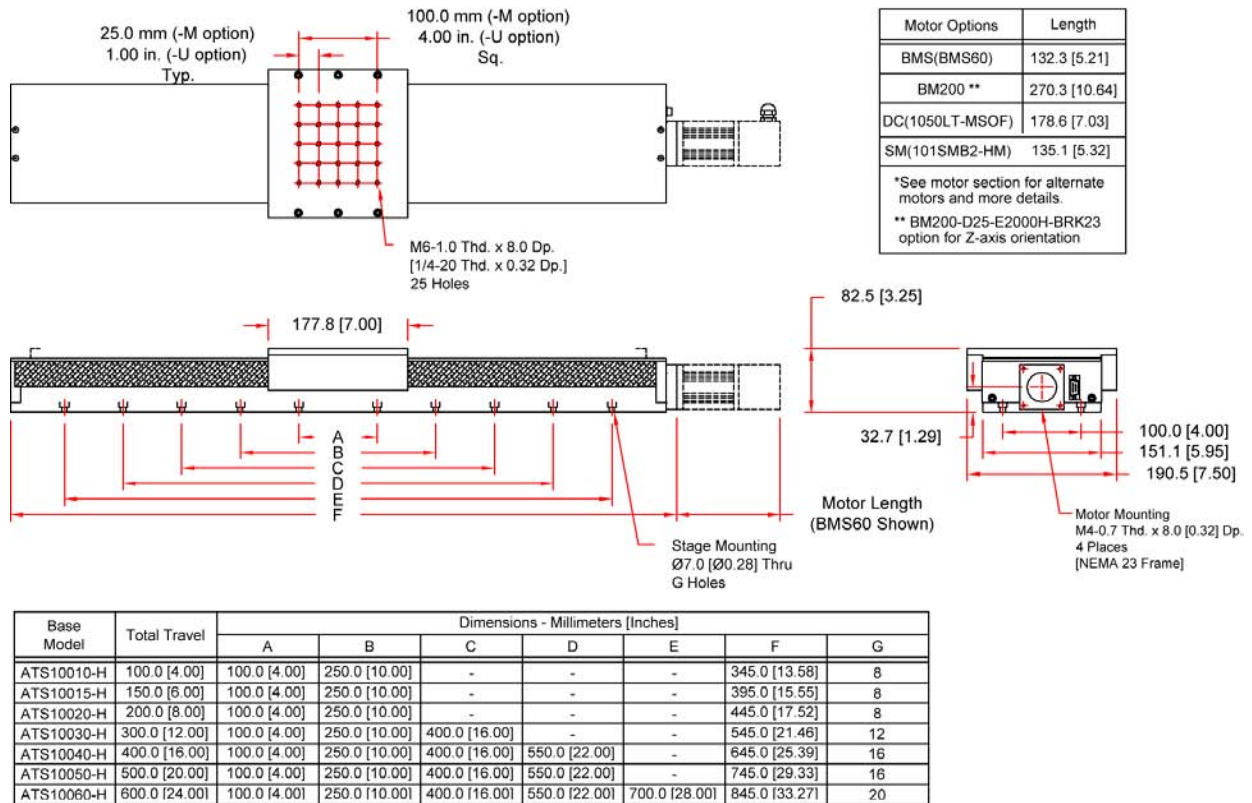

Figure 1-7: ATS1000-H Dimensions

1.3. Safety Procedures and Warnings

The following statements apply throughout this manual. Failure to observe these precautions could result in serious injury to those performing the procedures and damage to the equipment.

This manual and any additional instructions included with the stage should be retained for the lifetime of the stage.



DANGER

To minimize the possibility of electrical shock and bodily injury or death, disconnect all electrical power prior to making any electrical connections.



DANGER

To minimize the possibility of electrical shock and bodily injury or death when any electrical circuit is in use, ensure that no person comes in contact with the circuitry when the stage is connected to a power source.



DANGER

To minimize the possibility of bodily injury or death, disconnect all electrical power prior to making any mechanical adjustments.



DANGER

Moving parts of the stage can cause crushing or shearing injuries. All personnel must remain clear of any moving parts.



WARNING

Improper use of the stage can cause damage, shock, injury, or death. Read and understand this manual before operating the stage.



WARNING

If the stage is used in a manner not specified by the manufacturer, the protection provided by the stage can be impaired.



WARNING

Stage cables can pose a tripping hazard. Securely mount and position all stage cables to avoid potential hazards.



WARNING

Do not expose the stage to environments or conditions outside the specified range of operating environments. Operation in conditions other than those specified can cause damage to the equipment.



WARNING

The stage must be mounted securely. Improper mounting can result in injury and damage to the equipment.



WARNING

Use care when moving the stage. Manually lifting or transporting stages can result in injury.



WARNING

Only trained personnel should operate, inspect, and maintain the stage.



WARNING

This stage is intended for light industrial manufacturing or laboratory use. Use of the stage for unintended applications can result in injury and damage to the equipment.



WARNING

Before using this stage, perform an operator risk assessment to determine the needed safety requirements.

1.4. EC Declaration of Incorporation

Manufacturer: Aerotech, Inc.
101 Zeta Drive
Pittsburgh, PA 15238
USA



herewith declares that the product:

Aerotech, Inc. ATS1000 Stage

is intended to be incorporated into machinery to constitute machinery covered by the Directive 2006/42/EC as amended;

does therefore not in every respect comply with the provisions of this directive;

and that the following harmonized European standards have been applied:

EN ISO 12100-1,-2:2003+A1:2009

Safety of machinery - Basic concepts, general principles for design

ISO 14121-1:2007

Safety of machinery - Risk assessment - Part 1: Principles

EN 60204-1:2005

Safety of machinery - Electrical equipment of machines - Part 1: General requirements

and further more declares that

it is not allowed to put the equipment into service until the machinery into which it is to be incorporated or of which it is to be a component has been found and declared to be in conformity with the provisions of the Directive 2006/42/EC and with national implementing legislation, i.e. as a whole, including the equipment referred to in this Declaration.

Authorized Representative: Manfred Besold
Address: AEROTECH GmbH
Süd-West-Park 90
D-90449 Nürnberg

Name:

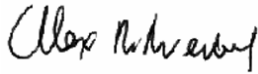
Alex Weibel / 
Engineer Verifying Compliance

Position:

Location: Pittsburgh, PA

Date: April 7, 2011

Chapter 2: Installation

This chapter describes the installation procedure for the ATS1000 stage, including handling the stage properly, preparing the mounting surface to accept the stage, securing the stage to the mounting surface, attaching the payload, and making the electrical connections.



WARNING

Installation must follow the instructions in this chapter. Failure to follow these instructions could result in injury and damage to the equipment.

2.1. Unpacking and Handling the Stage

Carefully remove the stage from the protective shipping container. Set the stage on a smooth, flat, and clean surface. This is a simple, yet very important step in maintaining the integrity of the stage. Each stage has a label listing the system part number and serial number. These numbers contain information necessary for maintaining or updating system hardware and software. Locate this label and record the information for later reference. If any damage has occurred during shipping, report it immediately.



WARNING

Improper stage handling could adversely affect the stage's performance. Therefore, use care when moving the stage. Manually lifting or transporting the stage can cause injury.



WARNING

Lift the stage only by the base.



WARNING

Do not use the ballscrew or motor as lifting points.

2.2. Preparing the Mounting Surface

The mounting surface should be flat and have adequate stiffness in order to achieve the maximum performance from the ATS1000. When an ATS1000 series stage is mounted to a non-flat surface, the stage can be distorted as the mounting screws are tightened. This distortion will decrease the overall accuracy of the stage. *To maintain accuracy, the mounting surface should be flat within $1\mu\text{m}$ per 50mm.* Adjustments to the mounting surface must be done before the stage is secured. The effects of flatness on mounting are illustrated in Figure 2-1.

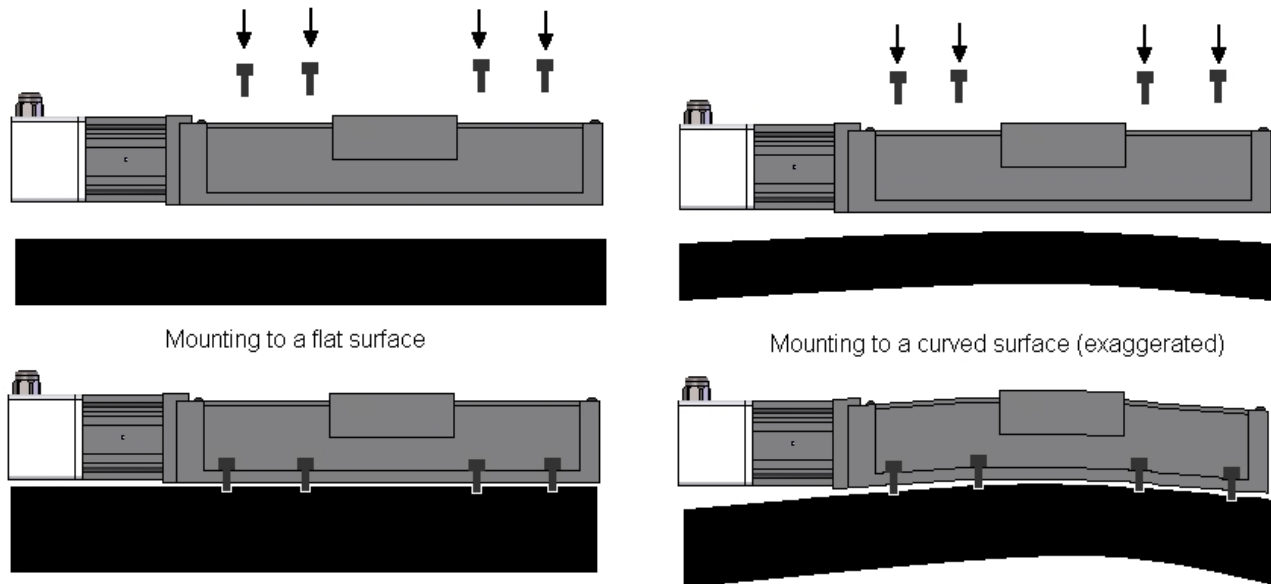

Figure 2-1: Results of Flat Versus Non-Flat Mounting

NOTE: The stage housing is precision machined and verified for flatness prior to stage assembly at the factory. If machining is required to achieve the desired flatness, it should be performed on the mounting surface rather than the stage base. Shimming should be avoided if possible. If shimming is required, it should be minimized to improve the rigidity of the system.

2.2.1. Securing the Stage to the Mounting Surface

The standard version of the stage (no hardcover or bellows) allows unobstructed access to the stage mounting holes. If necessary, manually move the stage table to access the slotted, counter-bored mounting holes along the edges of the stage (refer to Figure 2-2). Install the appropriately sized mounting screws (M6 or 1/4") through the mounting holes and secure the stage to the mounting surface. Repeat this process for each set of mounting holes.



WARNING

The stage must be mounted securely. Improper mounting can result in injury and damage to the equipment.

NOTE: The stage table may offer a considerable amount of resistance when it is moved manually. This is especially true if the stage is fitted with a motor assembly.

NOTE: If the stage is not connected to a power source, and is not equipped with an optional brake, it should be possible to move the stage table by hand with steady even pressure. Do not attempt to manually move the stage if it is connected to a power source or includes an integrated brake.

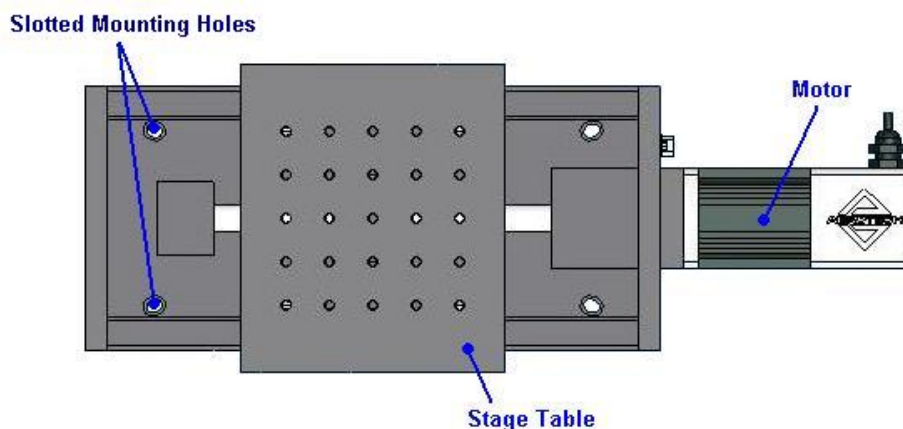

Figure 2-2: Top view of an ATS1000 Stage Showing Mounting Holes

2.2.2. Securing the Stage to the Mounting Surface (Hardcover)

In order to gain access to the mounting holes, the hardcover must first be removed. To do this, first remove the screws on the edges of the hard cover (see Figure 2-3) and slide it out from the side opposite of the motor. This can be done without removing the table. Once the hardcover is removed, follow the instructions in Section 2.2.1.

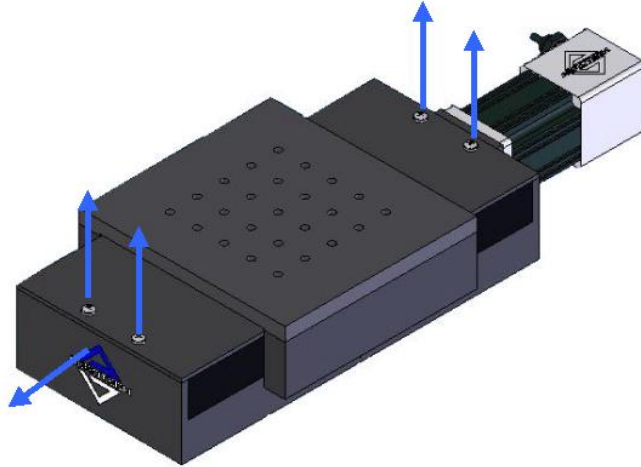

Figure 2-3: Hardcover Removal

2.2.3. Securing the Stage to the Mounting Surface (Bellows)

Velcro is used to connect the bellows to the stage carriage and endplates (Figure 2-4). To gain access to the stage mounting holes, disconnect the Velcro at these points and compress the bellows to one side. Once the bellows are removed, follow the instructions in Section 2.2.1.

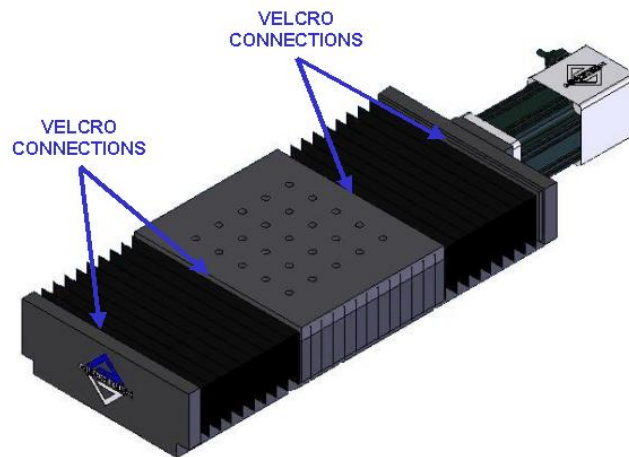

Figure 2-4: Bellows Removal

2.3. Attaching the Payload to the Stage

To prevent damage to payloads, test the operation of the stage before the payload is attached to the stage table. Proceed with the electrical installation and test the motion control system in accordance with the system documentation. Document all results for future reference. For information on electrical connections, refer to Section 2.4.

The payload should be flat, rigid, and comparable to the stage in quality.

NOTE: For valid system performance, the mounting interface should be flat within 2 μm per 25 mm.

Refer to Chapter 3: Operating Specifications for information on cantilevered loads and load positioning.

2.4. Electrical Installation

Electrical installation requirements will vary depending on stage options. Installation instructions in this section are for stages equipped with standard Aerotech motors intended for use with an Aerotech motion control system. Contact Aerotech for further information regarding stages that are otherwise configured.

Aerotech motion control systems are adjusted at the factory for optimum performance. When the ATS1000 series stage is part of a complete Aerotech motion control system, setup involves connecting a stage and motor combination to the appropriate drive chassis with the cables provided. Connect the provided cables to the motor and feedback connectors on the stage. Labels on the drive indicate the appropriate connections. Refer to your drive manuals and documentation for additional installation and operation information. In some cases, if the system is uniquely configured, a drawing showing system interconnects is supplied.

Refer to Section 3.6. for standard motor wiring and connector pin outputs.



WARNING

Never connect or disconnect any electrical component or connecting cable while power is applied, or serious damage can result.



WARNING

The stage's protective ground is located on pin A4 of the motor connector. If you are using cables other than those provided by Aerotech, you must connect pin A4 to a ground connection.

2.4.1. Standard Aerotech Motor options

ATS1000 stages have four available motor options. These options are summarized in Table 2-1. All ATS1000 stages come equipped with a mounting flange compatible with NEMA 23 motors. The details of this flange can be seen in Figure 2-5.

Table 2-1: ATS1000 Motor Options

Motor Options	
-BMS	Brushless servo motor with connectors and 2000-line encoder; requires cable (BMS60-A-D25-E2000H)
-DC	DC servo motor with connector and 2000-line encoder; requires cable (1050LT-MSOF-E2000LD)
-SM	Stepping motor with connector and home marker pulse (one per rev); requires cable (101SMB2-HM)
-NM	No motor or encoder

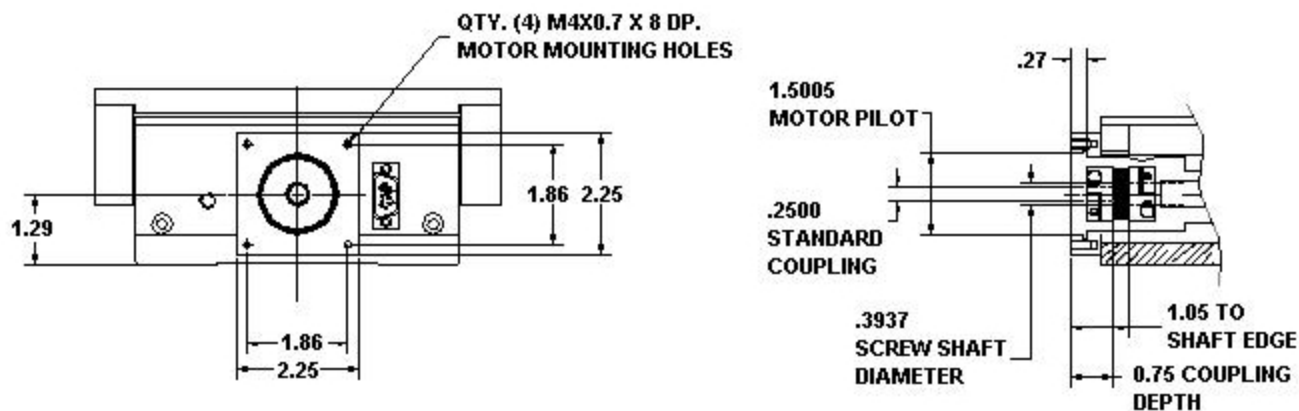

Figure 2-5: ATS1000 Stage NEMA 23 Motor Mounting Flange

2.4.2. Motor Foldback Options

When the foldback option is chosen, a motor with a standard NEMA 23 frame size may be used. Either a 6.35mm (1/4") shaft or a 9.53mm (3/8") shaft size can be specified when ordering the stage. The belt pulleys are attached to the motor shaft with two set screws. See Figure 4-3 for an illustration showing the location of the set screws as well as the entire pulley and belt power transfer system.

2.4.3. Optical Limit Switches

ATS1000 stages are equipped with a pair of optical limit switches. On the ATS1000 stages, the wiring for these limit switches terminates in a 9-pin connector on the end plate of the stage. The position of this connector can be seen in Figure 2-6.

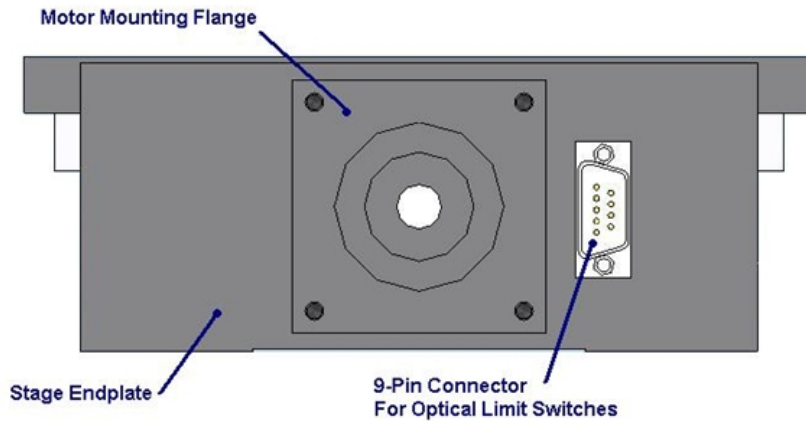

Figure 2-6: ATS1000 Stage Showing Limit Switch Connector

Chapter 3: Operating Specifications

The surrounding environment and operating conditions can affect the performance and service life of the stage. This chapter provides information on ideal environmental and operating conditions. Also included are instructions for estimating load and torque required to turn the ballscrew given various loadings.

3.1. Environmental Specifications

The environmental specifications for the ATS1000 are listed in the following table.

Table 3-1: Environmental Specifications

Ambient Temperature	Operating: 10° to 35° C (50° to 95° F) The optimal operating temperature is 20° C ±2° C (68° F ±4° F). If at any time the operating temperature deviates from 20° C degradation in performance could occur. Contact Aerotech for information regarding your specific application and environment.
	Storage: 0° to 40° C (32° to 104° F) in original shipping packaging
Humidity	Operating: 40 percent to 60 percent RH The optimal operating humidity is 50 percent RH.
	Storage: 30 percent to 60 percent RH, non-condensing in original packaging
Altitude	Operating: 0 to 2,000 m (0 to 6,562 ft) above sea level Contact Aerotech if your specific application involves use above 2,000 m or below sea level.
Vibration	Use the system in a low vibration environment. Excessive floor or acoustical vibration can affect stage and system performance. Contact Aerotech for information regarding your specific application.
Dust Exposure	The ATS1000 stages are not suited for dusty or wet environments. This equates to an ingress protection rating of IP00. With the hardcover (-H) or full bellows (-B) options the ATS1000 stages have limited protection against dust, but not water. This equates to an ingress protection rating of IP50.
Use	Indoor use only



Do not expose the stage to environments or conditions outside the specified range of operating environments. Operation in conditions other than those specified can cause damage to the equipment.

3.2. Accuracy and Temperature Effects

The accuracy specification of ATS1000 series stages is measured at the center of travel 45mm above the table with the stage in a horizontal position.

The accuracy of the ballscrew is a key element in the overall positioning accuracy. A scale error can be expected if temperature of the ballscrew differs from 20° C (68° F). The greater the temperature difference, the greater the error. The temperature of the ballscrew depends on the speed and duty cycle of the stage. The faster the movement and higher the duty cycle, the more the stage accuracy will be affected by heat.

3.3. Basic Specifications

Basic ATS1000 series positioning stage specifications are shown in Table 3-2. Motor specifications are shown in Table 3-3.

Table 3-2: ATS1000 Series Specifications

ATS1000Series		ATS10010	ATS10015	ATS10020	ATS10030
Total Travel		100 mm (4 in)	150 mm (6 in)	200 mm (8 in)	300 mm (12 in)
Drive System		Precision Ball Screw			
Accuracy	Standard	±4 µm	±6 µm	±8 µm	±12 µm
	HALAR	±1.0 µm			
Resolution (8 mm/rev lead)		1.0 µm @ 2000 steps/rev Motor Resolution			
Maximum Travel Speed		400 m/s			
Maximum Load		70 kg (horizontal), 35 kg (vertical), 35 kg (side)			
Bidirectional Repeatability		±1.0 µm standard; ±0.5 µm with HALAR			
Straightness and Flatness		±2.4 µm	±3.6 µm	±4.8 µm	±7.2 µm
Construction		Aluminum Body/Black Anodize Finish/Hardcoat			
Nominal Stage Weight (with motor)	ATS1000	7.2 kg (15.9 lb)	7.7 kg (16.9 lb)	NA	9.4 kg (20.7 lb)
	ATS1000-B	8.1 kg (17.8 lb)	8.7 kg (19.1 lb)	NA	10.8 kg (23.8 lb)
	ATS1000-H	8.0 kg (17.7 lb)	8.7 kg (19.1 lb)	9.4 kg (20.6 lb)	11.0 kg (24.2 lb)

Table 3-2: ATS1000 Series Specification (continued)

ATS1000Series		ATS10040	ATS10045	ATS10050	ATS10060
Total Travel		400 mm (12 in)	450 mm (18 in)	500 mm (20 in)	600 mm (24 in)
Drive System		Precision Ball Screw			
Accuracy	Standard	±16 µm	±18 µm	±20 µm	±24 µm
	HALAR	±1.0 µm			
Resolution (8 mm/rev lead)		1.0 µm @ 2000 steps/rev Motor Resolution			
Maximum Travel Speed		400 m/s			
Maximum Load		70 kg (horizontal), 35 kg (vertical), 35 kg (side)			
Bidirectional Repeatability		±1.0 µm standard; ±0.5 µm with HALAR			
Straightness and Flatness		±9.6 µm	±10.8 µm	±12.0 µm	±14.4 µm
Construction		Aluminum Body/Black Anodize Finish/Hardcoat			
Nominal Stage Weight (with motor)	ATS1000	10.4 kg (22.9 lb)	11.0 kg (24.2 lb)	NA	12.6 kg (27.7 lb)
	ATS1000-B	12.4 kg (27.3 lb)	13.4 kg (29.5 lb)	NA	15.5 kg (34.1 lb)
	ATS1000-H	12.3 kg (27.1 lb)	NA	13.9 kg (30.5 lb)	15.4 kg (33.9 lb)
<p>All performance specifications based on precision mounting surface flat to within ±.002 mm / 300 mm and are measured on a single axis basis.</p> <p>Repeatability and accuracy include linearity correction and minimum thermal change during measurement.</p> <p>Vertical and axial loads subject to cantilever load restriction.</p> <p>Selected motor and drive will limit performance specifications.</p> <p>Consult factory for XY and alternate mounting configurations.</p>					

Table 3-3: ATS1000 Series Motor Specifications

Model	BMS60	
Winding Designation	-A	
Performance Specifications (1,5)		
Stall Torque, Continuous (2)	N-m	0.33
	oz-in	46.2
Peak Torque (3)	N-m	1.31
	oz-in	184.9
Rated Speed	rpm	4,000
Rated Power Output, Continuous	watts	112.0
Electrical Specifications (5)		
BEMF Constant (line to line, max)	Volts pk / krpm	19.0
Continuous Current, Stall (2)	Amp pk	2.3
	Amp rms	1.6
Peak Current, Stall (3)	Amp pk	9.2
	Amp rms	6.5
Torque Constant (4,8)	N-m / Amp pk	0.14
	oz-in / Amp pk	20.1
	N-m / Amp rms	0.20
	oz-in / Amp rms	28.4
Motor Constant (2,4)	N-m / \sqrt{W}	0.050
	oz-in / \sqrt{W}	7.02
Resistance, 25 °C (line to line)	ohms	8.4
Inductance (line to line)	mH	1.30
Maximum Bus Voltage	VDC	340
Thermal Resistance	°C / W	1.73
Number of Poles	P	8
<p>(1) Performance is dependent upon heat sink configuration, system cooling conditions, and ambient temperature</p> <p>(2) Values shown @ 75 °C rise above a 25 °C ambient temperature, with housed motor mounted to a 250 mm x 250 mm x 6 mm aluminum heat sink</p> <p>(3) Peak torque assumes correct rms current, consult Aerotech</p> <p>(4) Torque Constant and Motor Constant specified at stall</p> <p>(5) All performance and electrical specifications +/- 10%</p> <p>(6) Maximum winding temperature is 100 °C, Thermistor trips at 100 °C</p> <p>(7) Ambient operating temperature range: 0 °C - 25 °C, consult Aerotech for performance in elevated ambient temperatures</p> <p>(8) All Aerotech amplifiers are rated Apk; use torque constant in N-m / Apk when sizing</p>		

3.4. Load Capability

It is recommended that application loads be symmetrically distributed whenever possible (i.e., the payload should be centered on the stage table and the entire stage should be centered on the support structure). With the stage lying flat (horizontal) and the application load vertically applied and symmetrically distributed, the maximum vertical load carrying capacity of ATS1000 stages is 50 kg. If cantilevered loads are applied, refer to Figure 3-1 to find the maximum allowable load.

In Figure 3-1, two curves are shown for different loading conditions. The Lvc or “vertical cantilever” curve is for situations where the stage is mounted in a vertical orientation and the payload is mounted to the table top with its center of gravity extended outward. The Lsc or “side cantilever” curve assumes a horizontal stage orientation. If a cantilevered load situation is used, first determine if it is a vertical cantilever or side cantilever system based on 3.4. Measure the cantilever length, then find the corresponding load value from Figure 3-1.

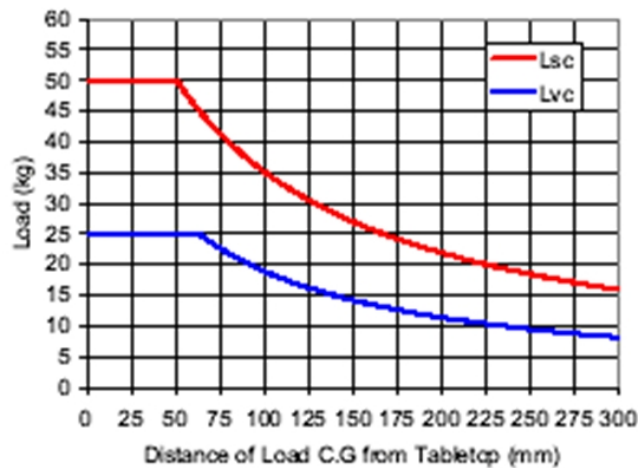

Figure 3-1: Load Capability of ATS1000 Series Stages

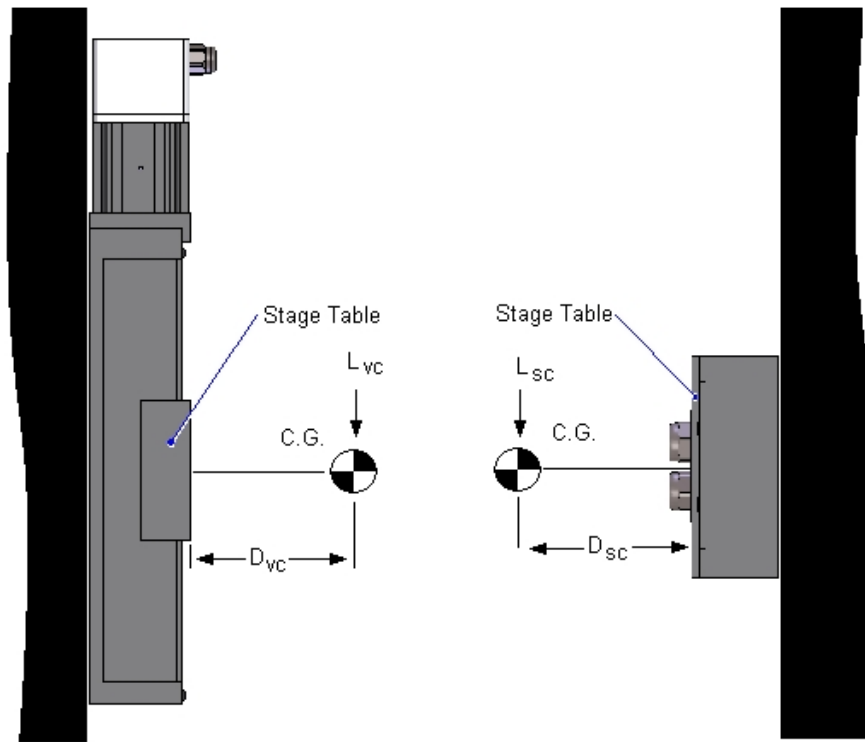

Figure 3-2: Stage Orientations for L_{vc} and L_{sc}

The approximate amount of torque required to turn the ballscrew of an ATS1000 series stage can be found from Figure 3-3 or the following equation:

$$Torque_{REQ} = \frac{(Axial\ Load) \times (Lead\ of\ Screw)}{2 \times \pi \times (Efficiency)}$$

For ATS1000 series stages, the ballscrew efficiency is rated at 90% (0.90). Refer to Figure 3-3.

The maximum axial load carrying capacity of ATS1000 stages is 35 kg (77.1 lb)

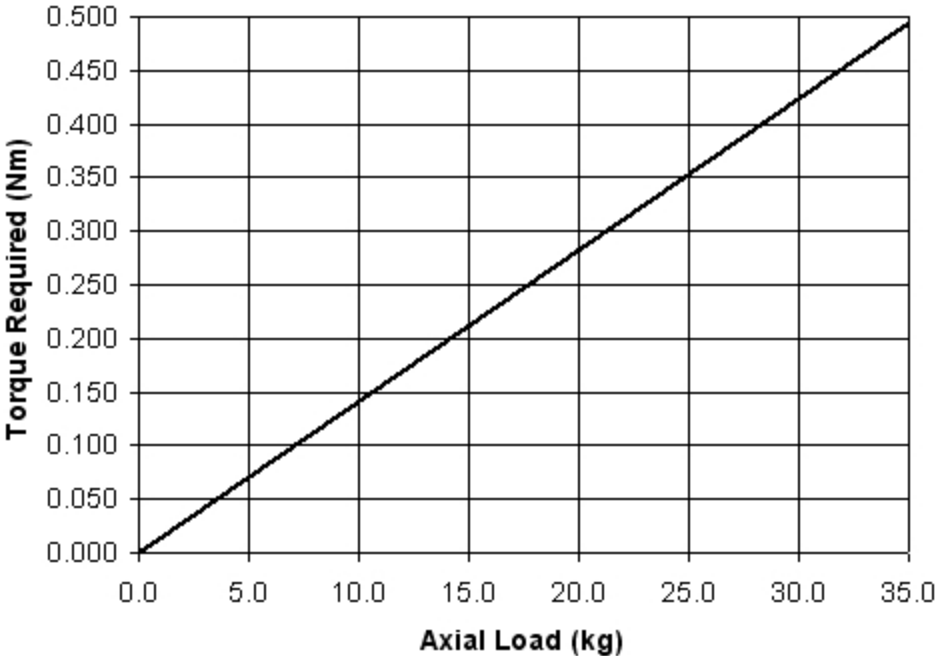

Figure 3-3: Torque Required to Turn ATS1000 Ballscrew with Various Loads

3.5. Optical Limit Switch

ATS1000 series stages are provided with a pair of optical limit switch assemblies mounted to the bottom of the stage table. The limit switches signal when the stage table has reached its maximum useable travel distance in both directions.

3.5.1. Limit Switch Operation

Each limit switch has a light source and detector mounted to a small printed circuit board. Each limit switch-board is mounted at the ends of the stage with their emitter–detector axes perpendicular to the direction of table motion. On a standard stage, the clockwise (CW) switch is located at the end opposite the motor. When movement of the stage table causes the blade mounted to the stage carriage, to break the light beam from the emitter to the detector, a CW or counterclockwise (CCW) limit signal is generated. The limit switch itself can be configured as normally closed (NC) or normally open (NO).



If the stage is driven approximately 2.0 revolutions (10mm) beyond the electrical limit, it will encounter a mechanical stop. Although the operating speed of the stage may be relatively slow, damage to the stage could result.

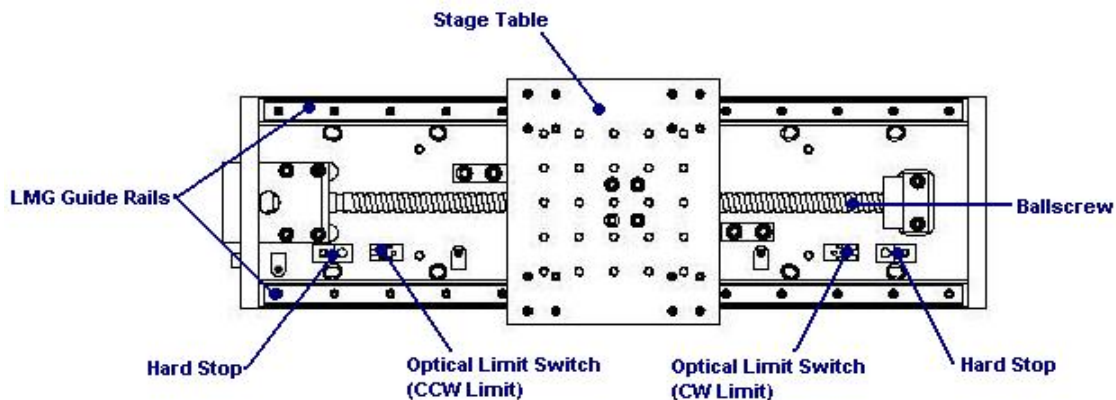

Figure 3-4: Internal View of a Typical Stage Showing Limit Switches

NOTE: The terms clockwise (CW) and counterclockwise (CCW) refer to the direction of motor rotation while looking into the shaft of the motor. For ATS125 series stages, a clockwise (CW) rotation of the motor causes the stage table to move away from the motor. Counterclockwise (CCW) rotation of the motor causes the stage table to move toward the motor. The exception is if an optional "fold back" option is used, in which case the directions are reversed.

3.5.2. Limit Switch Wiring

Limit switches are open-collector, TTL-compatible, electro-optical devices powered by 5 Volts that change output states when the stage approaches its maximum travel distance and breaks the light beam. Since they are open-collector devices, they may be interfaced to 24V logic inputs. Each limit switch is mounted on a small printed circuit board. Standard ATS1000 Stages include limit switch wiring integrated into one of the two main connectors, but stages with the foldback option include a separate 9-pin limit switch connector, detailed in Figure 3-5.

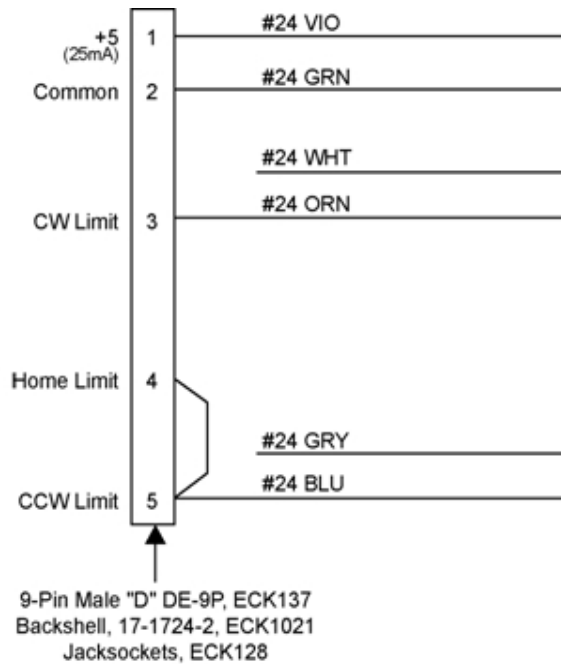

Figure 3-5: ATS1000 Series 9-pin Limit Switch Wiring (Foldback Equipped Stages Only)

Assuming a NC limit configuration, the input to the controller is seen as a logic 0 (typical 0.4V @ 12.8mA) when no limit condition is present. When the limit switch is activated, a 5V source through a pull-up resistor causes a logic 1 (typically 4.8-5V) to be seen by the controller input. The limit switch operation for a NO limit configuration is the exact opposite as described above. See Figure 3-6 for a diagram of limit switch wiring.

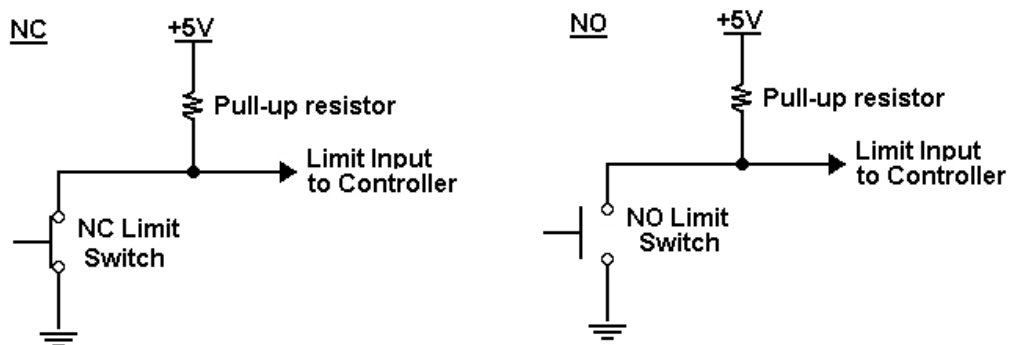

Figure 3-6: Normally Closed (NC) and Normally Open (NO) Limit Switch Wiring

3.6. Standard Motor Wiring

Stages fitted with standard motors and encoders come from the factory completely wired and assembled. For reference, connector pin outputs and general wiring information is given in the following figures. Pin outputs are defined in Table 3-4.

NOTE: Refer to the other documentation accompanying your Aerotech equipment. Call your Aerotech representative if there are any questions on system configuration.

NOTE: If you are using your own cables to connect the stage, ensure that the motor and ground wires can handle current higher than the continuous current listed in Table 3-3. The voltage rating of the wire insulation must be greater than the maximum bus voltage listed in Table 3-3.

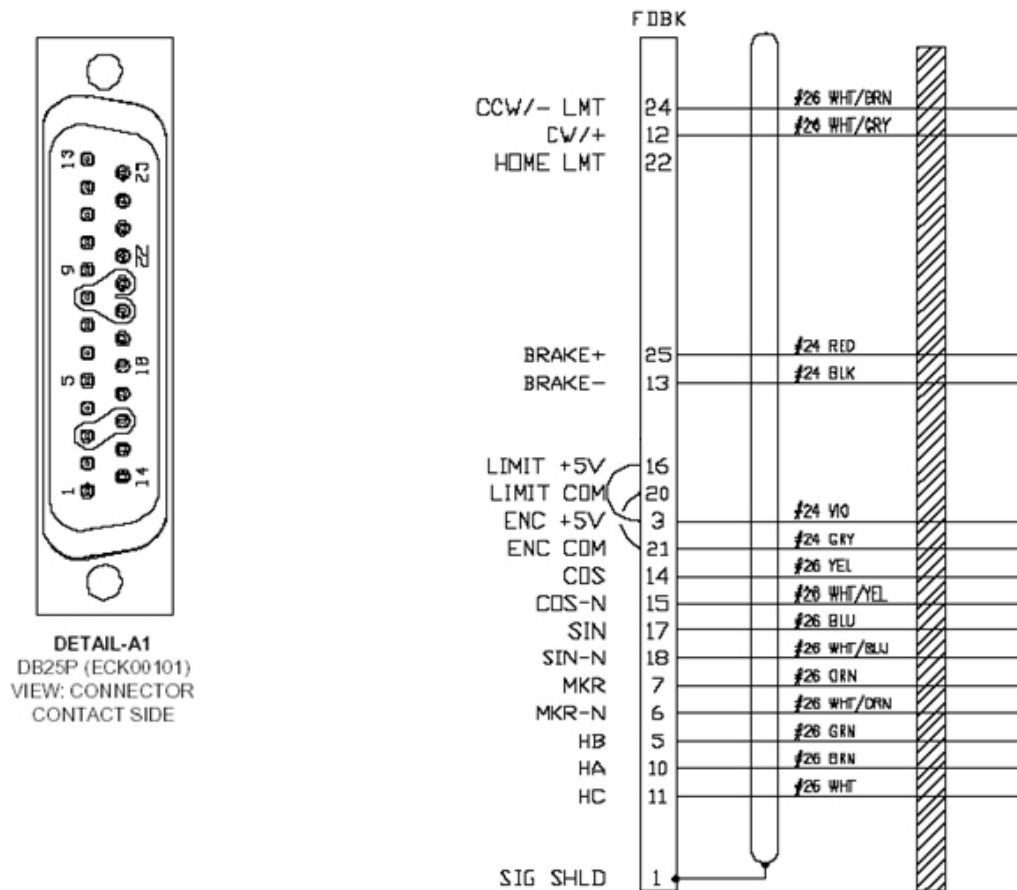

Figure 3-7: Limit, Brake, and Encoder Wiring for Standard ATS1000 Stages with Integral Motor

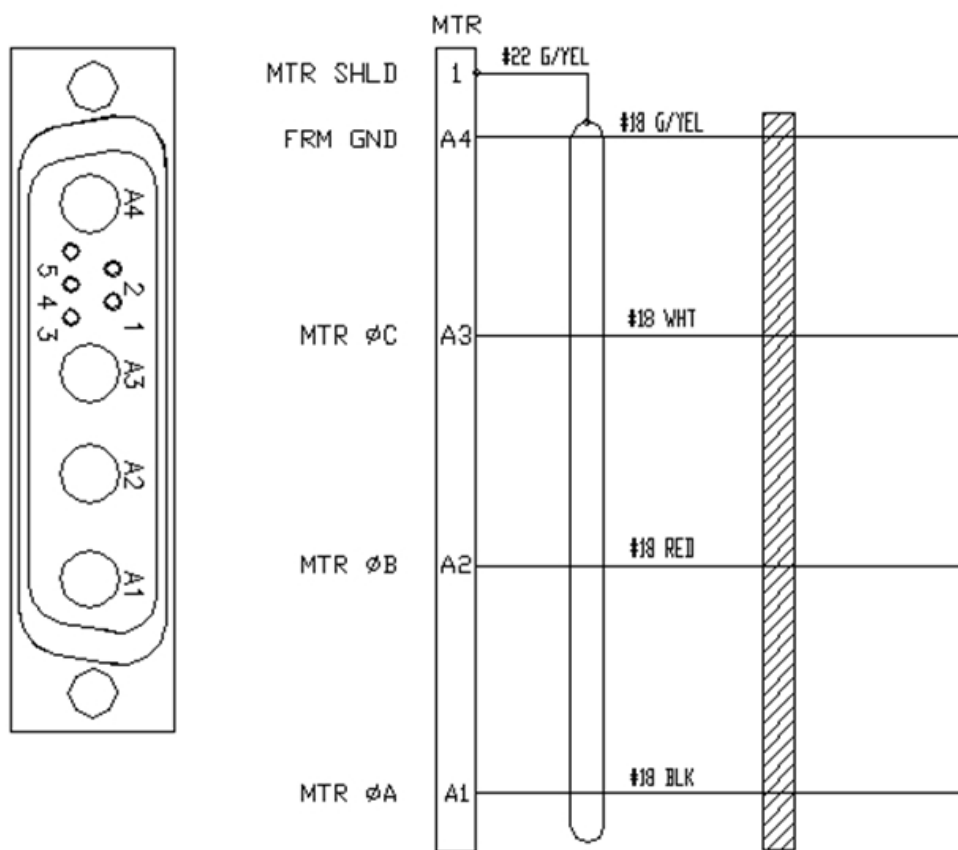

Figure 3-8: Motor Wiring Connector for all ATS1000 Stages

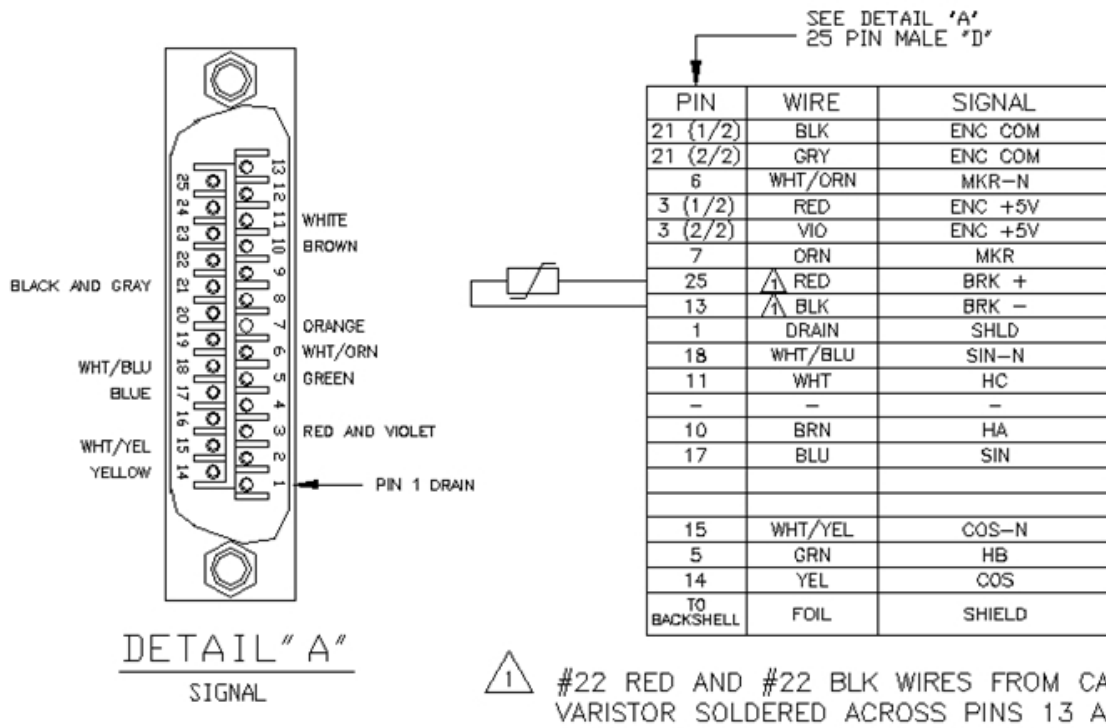

Figure 3-9: Brake and Encoder Connector for Stages with Foldback Option

Table 3-4: Motor Wiring Pinout Descriptions

Pin Output	Description
Clockwise (CW/+) Limit	Active high signal indicating maximum travel produced by CW motor rotation. Normally not used on ATS1000 stage with standard limit switch wiring.
CW Limit N	Active low signal indicating stage maximum travel produced by CW motor rotation.
COS	Cosine. Incremental encoder output; either TTL line driven or amplified sine wave type signal.
COS-N	Incremental encoder output. Complement of cos.
Counter-clockwise (CCW/-) Limit	Active high signal indicating stage maximum travel produced by CCW motor rotation.
CCW Limit N	Active low signal indicating stage maximum travel produced by CCW motor rotation.
HOME LMT	Home Limit. Paralleled with CCW/- (with Standard Jumper) or CW/+ (Optional Jumper) limit. Typically not used.
ENC +5V	+5 V supply input for optical encoders. Typical requirement is 250 mA.
ENC COM	+ 5 V return for optical encoders (ground).
HA	Hall Effect A. Brushless motor commutation track output. TTL line driven signal with rotary motor.
HB	Hall Effect B. Brushless motor commutation track output. TTL line driven signal with rotary motor.
HC	Hall Effect C. Brushless motor commutation track output. TTL line driven signal with rotary motor.
LMT +5v	+ 5 V supply input for optical limit switch boards. Typical requirement is 50 mA.
LMT COM	+ 5 V return for optical limit switch boards (ground).
MKR	Marker. Incremental encoder output pulse given once per revolution. Typically used for home reference cycle.
MKR-N	Incremental encoder output; either the compliment of Marker with a line driven, TTL type encoder or 2.5 V DC bias level with amplified sine wave type encoder.
SIN	Sine. Incremental encoder output; either TTL line driven or amplified sign wave type signal.
SIN-N	Incremental encoder output. Complement of sin.
MTR ØA	Motor Phase A.
MTR ØB	Motor Phase B.
MTR ØC	Motor Phase C.
BRAKE +	Brake +24 VDC, 250 mA.
BRAKE -	Brake 24 VDC Common.

3.7. Vacuum Operation

Aerotech will prepare the ATS1000 series stage for operation in vacuum environments. Aerotech offers two vacuum preparation options; one for low vacuum (for use in atmospheric pressures to 10^{-3} torr) and one for high vacuum (preparation for environments from 10^{-3} to 10^{-6} torr). As part of this preparation, attention to detail during modification, cleaning, and assembly results in stages with optimal performance in vacuum applications. This chapter will outline preparation techniques for stages that will operate in a vacuum. Some techniques covered are:

- Lubrication with vacuum-compatible lubricants
- Use of materials, fasteners, and coatings with vacuum outgas performance compatible with the level of vacuum specified
- For high vacuum stages, elimination of situations that may allow gases to become temporarily trapped during pump down
- Extensive cleaning prior to assembly in a clean environment and packaging in a special polyethylene bag

3.7.1. Special Guidelines

To ensure that the stage will continue to perform well in the vacuum environment, follow the guidelines listed below (in addition to standard handling, installation, and lubrication guidelines outlined earlier in this manual).

1. Do not remove the stage from the sealed bag until it is ready for use.
2. Always handle the stage in a clean environment and use powder-free polyethylene gloves to prevent any contaminants from adhering to the surface of the stage.
3. During installation, use cleaned, vented, stainless steel fasteners when securing the stage.
4. Reduced air pressure eliminates significant convective heat transfer. This, coupled with the viscous vacuum-compatible lubricants, could result in excessive motor operating temperatures. Because of this, consider all continuous torque ratings to be 40 to 60% lower than the value specified for operation in normal atmospheric environment. Reduce motor usage accordingly.
5. For vacuum applications, the recommended lubricant is a small quantity of Braycote® 602EF grease or a substitute of equal quality.
6. Aerotech does not bake out vacuum components. Baking vacuum components between 100 and 125 °C for 24 to 48 hours significantly reduces outgassing at initial pump-down to vacuum pressure and evaporates water vapor that impregnates porous surfaces on the aluminum surfaces and Teflon cables. Aerotech recommends that customers bake out vacuum systems when first installing them in the vacuum chamber.

Chapter 4: Maintenance

This chapter will cover information about intervals between lubrications, detail the lubrication and inspection process, and cover which lubricants are recommended for use. Also included is a section on belt tension and adjustment on stages with the foldback option.

NOTE: The bearing area must be kept free of foreign matter and moisture; otherwise, the performance and life expectancy of the stage will be reduced. Always operate the stage with the hard cover and side seals in place to help keep dirt out.



To minimize the possibility of bodily injury, confirm that all electrical power is disconnected prior to making any mechanical adjustments.

4.1. Service and Inspection Schedule

Lubricant inspection and replenishment in ATS1000 series stages depends on conditions such as duty cycle, speed, and the environment. An inspection interval of once per month is recommended until a trend develops for the application. Longer or shorter intervals may be required to maintain the film of lubricant on the bearing surfaces. In general, it is recommended that stages operating in a clean environment be lubricated annually. For stages operating under conditions involving excessive debris, lubrication every six months is recommended. The ballscrew end bearings and motor bearings are sealed, and should not need to be lubricated under normal use.

4.2. Cleaning and Lubrication

4.2.1. Recommended Lubricants and Cleaning Solvents

For standard ballscrew assemblies and LMG guide rails, NSK LGU grease is recommended.

If a solvent is necessary for cleaning the stage, it is recommended that isopropyl rubbing alcohol be used. Harsher solvents, such as acetone, may damage the plastic and rubber seals on the ballscrew or LMG trucks.

For high-speed applications (i.e., near maximum speed at a duty cycle of 50%), frequent ballscrew maintenance with standard lubricants is required.

4.2.2. Important Notes on Lubrication

When cleaning and/or lubricating components of the ATS1000 series stages:

1. Be sure to use a clean, dry, soft, and lint-free cloth for cleaning.
2. Take the opportunity during the lubrication procedure to inspect the linear motion guides for any damage or signs of wear.
3. In applications that have multiple stages bolted together to form multi-axis systems, the orthogonality may be lost if the stage tables of the support stages are loosened. Precision aligned stages should not be loosened or disassembled.
4. Further disassembly of the stage is not recommended because proper assembly and calibration can only be done at the factory. In addition, a laser interferometer is required for post assembly verification to maintain warranties.

4.3. Lubrication and Cleaning Process

The lubrication and cleaning process is outlined in the steps that follow. Before beginning lubrication, please see Section 4.2.1. for recommended lubricants.

1. Drive the stage table to one end of travel and remove power to the stage.
2.
 - a. Hardcover Configuration: Remove the screws on the edges of the hard cover (Figure 4-1) and slide it out from the side opposite of the motor. This can be done without removing the table.
 - b. Bellows Configuration: Velcro is used to connect the bellows to the stage carriage and endplates (Figure 4-2). To gain access to the inner section of the stage, disconnect the Velcro at these points and compress the bellows to one side.
3. Remove any accumulated dust or debris from the inside of the assembly.
4. Remove any dirty or dried lubricant from the ballscrew. Use a clean, lint-free cloth with a side-to-side motion. Manually turn the ballscrew to clean its entire circumference. A swab soaked in Isopropyl Alcohol may be used to remove stubborn debris.
5. Clean the end of the ballscrew nut and wiper with a clean, lint-free cloth or swab.
6. Clean the linear bearing guides using a similar technique.
7. Apply a thin, continuous film of lubricant to the ballscrew threads and linear bearing guides. A good quality, natural bristle artist's brush makes an excellent applicator.
8. For stages without an optional brake, manually move the stage to the opposite end of travel. This will work the grease into the ballscrew and linear bearing guides. Depending on the pitch of the ballscrew, it may be necessary to turn the ballscrew by hand rather than simply push the stage manually. This can be done by turning the motor coupling. If the stage has an optional brake, the stage cannot be moved by hand. In this case, restore power to the stage, drive it to the desired position, then remove power and continue to step 9. Be sure to use extreme caution while operating the stage temporarily without the hardcover installed.
9. Repeat steps 3 through 7 for any areas covered by the original table position.
10. Refasten the hardcover.
11. Restore power to the stage, drive the stage table back to its original position to redistribute lubricants.



To minimize the possibility of bodily injury, confirm that all electrical power is disconnected prior to making any mechanical adjustments.

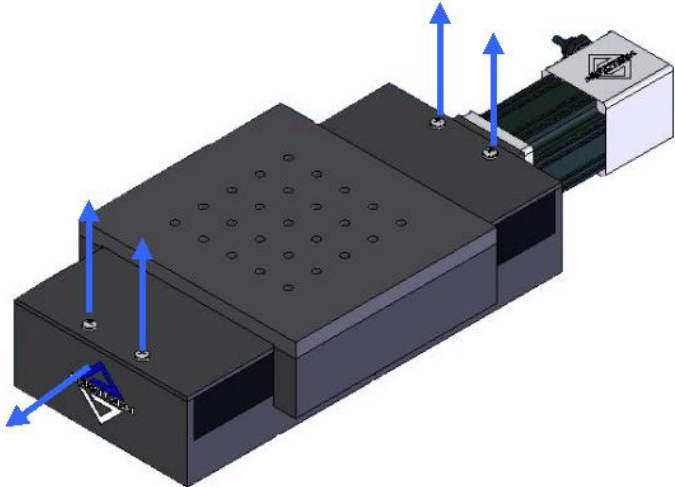

Figure 4-1: Hardcover Removal Procedure

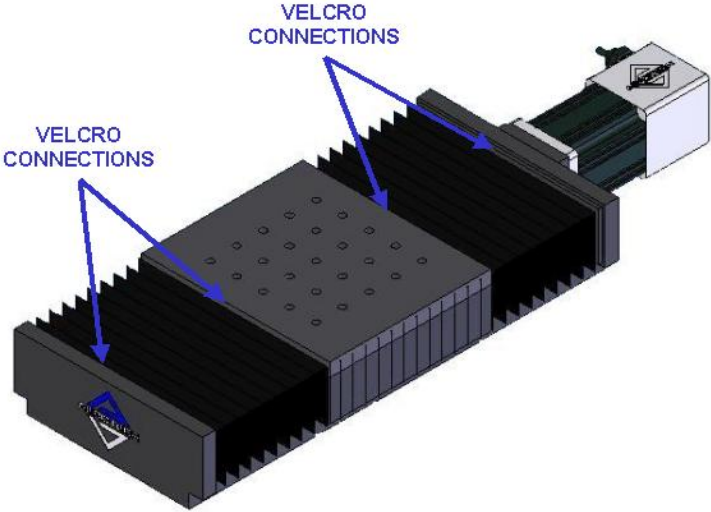

Figure 4-2: Bellows Removal Procedure

4.4. Belt Adjustment (Foldback Motor Option)

On foldback stages, the motor torque is transferred to the ballscrew via a timing belt. Belt tension is critical to stage performance and accuracy. When lubricating and cleaning the stage, it is recommended that belt tension be checked. Deflection in the belt should be less than 5 mm when applying a downward force directly between the pulleys (as shown by the large arrow) of approximately 5 N. If deflection exceeds this range, the belt tension should be adjusted. The method of adjustment is outlined below.

1. Remove power to the stage.
2. Remove the four mounting screws for the foldback cover.
3. Check the tension in the belt (described above) to determine if adjustment is necessary
4. If adjustment is required, loosen (but do not remove) the four motor mounting screws as shown below by small angled arrows.
5. As shown below, the motor mounting holes are slotted to allow for belt adjustment. With all four screws loose, pull the motor away from the stage by hand until desirable belt tension is achieved.
6. Tighten motor mounting screws and re-check the tension in the belt. Belt tension may change after the mounting screws are tightened, so if necessary repeat step 5 until desired tension is reached.
7. While adjusting tension, it is advisable to verify that the pulleys are tight on their respective shafts. Each pulley is held in position with two set screws. If a pulley is loose, it may be necessary to tighten one or both of these screws.
8. Once tension adjustment is complete, replace the foldback cover and mounting screws. Restore power to the stage.

NOTE: If the stage has been calibrated (HALAR), note the orientation of the two pulleys within regard to each other or recalibration might be required.

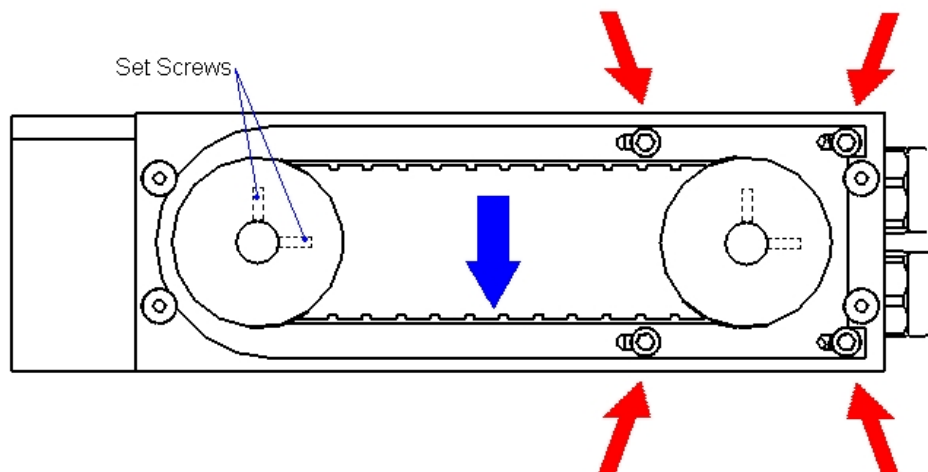

Figure 4-3: Belt Access and Adjustment on Foldback Models

Appendix A: Warranty and Field Service

Aerotech, Inc. warrants its products to be free from defects caused by faulty materials or poor workmanship for a minimum period of one year from date of shipment from Aerotech. Aerotech's liability is limited to replacing, repairing or issuing credit, at its option, for any products that are returned by the original purchaser during the warranty period. Aerotech makes no warranty that its products are fit for the use or purpose to which they may be put by the buyer, where or not such use or purpose has been disclosed to Aerotech in specifications or drawings previously or subsequently provided, or whether or not Aerotech's products are specifically designed and/or manufactured for buyer's use or purpose. Aerotech's liability or any claim for loss or damage arising out of the sale, resale or use of any of its products shall in no event exceed the selling price of the unit.

Aerotech, Inc. warrants its laser products to the original purchaser for a minimum period of one year from date of shipment. This warranty covers defects in workmanship and material and is voided for all laser power supplies, plasma tubes and laser systems subject to electrical or physical abuse, tampering (such as opening the housing or removal of the serial tag) or improper operation as determined by Aerotech. This warranty is also voided for failure to comply with Aerotech's return procedures.

Laser Products

Claims for shipment damage (evident or concealed) must be filed with the carrier by the buyer. Aerotech must be notified within (30) days of shipment of incorrect materials. No product may be returned, whether in warranty or out of warranty, without first obtaining approval from Aerotech. No credit will be given nor repairs made for products returned without such approval. Any returned product(s) must be accompanied by a return authorization number. The return authorization number may be obtained by calling an Aerotech service center. Products must be returned, prepaid, to an Aerotech service center (no C.O.D. or Collect Freight accepted). The status of any product returned later than (30) days after the issuance of a return authorization number will be subject to review.

Return Procedure

After Aerotech's examination, warranty or out-of-warranty status will be determined. If upon Aerotech's examination a warranted defect exists, then the product(s) will be repaired at no charge and shipped, prepaid, back to the buyer. If the buyer desires an airfreight return, the product(s) will be shipped collect. Warranty repairs do not extend the original warranty period.

Returned Product Warranty Determination

After Aerotech's examination, the buyer shall be notified of the repair cost. At such time, the buyer must issue a valid purchase order to cover the cost of the repair and freight, or authorize the product(s) to be shipped back as is, at the buyer's expense. Failure to obtain a purchase order number or approval within (30) days of notification will result in the product(s) being returned as is, at the buyer's expense. Repair work is warranted for (90) days from date of shipment. Replacement components are warranted for one year from date of shipment.

Returned Product Non-warranty Determination

At times, the buyer may desire to expedite a repair. Regardless of warranty or out-of-warranty status, the buyer must issue a valid purchase order to cover the added rush service cost. Rush service is subject to Aerotech's approval.

Rush Service

On-site Warranty Repair If an Aerotech product cannot be made functional by telephone assistance or by sending and having the customer install replacement parts, and cannot be returned to the Aerotech service center for repair, and if Aerotech determines the problem could be warranty-related, then the following policy applies:

Aerotech will provide an on-site field service representative in a reasonable amount of time, provided that the customer issues a valid purchase order to Aerotech covering all transportation and subsistence costs. For warranty field repairs, the customer will not be charged for the cost of labor and material. If service is rendered at times other than normal work periods, then special service rates apply.

If during the on-site repair it is determined the problem is not warranty related, then the terms and conditions stated in the following "On-Site Non-Warranty Repair" section apply.

On-site Non-warranty Repair If any Aerotech product cannot be made functional by telephone assistance or purchased replacement parts, and cannot be returned to the Aerotech service center for repair, then the following field service policy applies:

Aerotech will provide an on-site field service representative in a reasonable amount of time, provided that the customer issues a valid purchase order to Aerotech covering all transportation and subsistence costs and the prevailing labor cost, including travel time, necessary to complete the repair.

Company Address Aerotech, Inc.
101 Zeta Drive
Pittsburgh, PA
15238-2897

Phone: (412) 963-7470

Fax: (412) 963-7459

Appendix B: Technical Changes

Table B-1: Current Changes (1.03.00)

Section(s) Affected	General Information
Section 3.6.	Changed wiring diagram to remove pin 8

Table B-2: Archived Changes

Revision	Section(s) Affected	General Information
1.00.00	--	New Manual
1.01.00	Section 1.2.	Added Dimensions section
1.02.00	Section 1.2.	Updated stage dimensions
1.02.00	Section 1.4.	Added section
1.02.00	Section 3.1.	Added section
1.02.00	Chapter 2: Installation, Section 2.1. , Section 2.2.1. , Section 2.4. , and Section 1.3.	Added safety information and warnings
1.02.00	Section 3.3.	Added motor specifications
1.02.00	Section 3.6.	Added note about current requirements of motor and ground wires

Index

A		O	
Attaching the Payload.....	18	operating conditions.....	21
B		Optical Limit Switch.....	28
ball screw		Optical limit switches.....	2
temperature of.....	21	Optional Features.....	3
C		P	
cable.....	18	Preparing the Mounting Surface.....	14
Cleaning.....	36	S	
clockwise (CW) switch.....	28	safety procedures.....	9
counterclockwise (CCW) switch.....	28	Securing the Stage to the Mounting Surface.....	15
CW and CCW terminology.....	28	Specifications.....	22
D		stage table.....	15
Declaration of Incorporation.....	11	Standard Features.....	2
Dimensions.....	6	T	
E		temperature effects.....	21
Electrical Installation.....	18	travel distance.....	1
encoders.....	30	U	
Environmental Specifications.....	21	Unpacking and Handling the Stage.....	13
L		V	
limit switches.....	2	vacuum preparation.....	34
lubricants		W	
recommended.....	36	Warnings.....	9
Lubrication.....	36	wiring.....	29
lubrication and cleaning.....	37		
lubrication schedule.....	35		
M			
model numbers.....	13		
multiaxis combinations.....	36		

