

# FLASH2

## USER'S MANUAL

For the Operation Procedures

Windows Japanese Environment

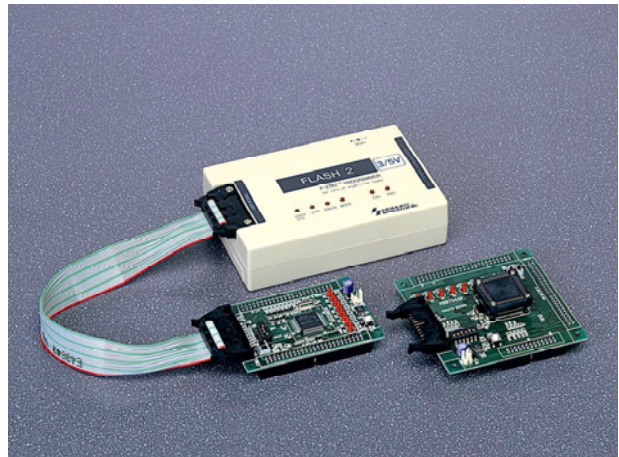

### Contents

● <b>IMPORTANT</b> .....	<b>1</b>
◆ MATTERS ON SAFETY .....	1
◆ THINGS OF IMPORTANCE .....	1
◆ LIMITED GUARANTEE .....	1
◆ WHAT THIS GUARANTEE DOES NOT INCLUDE .....	1
● <b>FLASH2 Features</b> .....	<b>2</b>
◆ Product and contained accessories .....	2
◆ The provided CD includes .....	2
◆ Specifications .....	3
◆ Parts Name .....	4
◆ Connectors & Cables .....	5
◆ How to Purchase the Upgrading Control Software .....	5
◆ High Speed Clocked Synchronous Communication of FLASH MATE 5V1 ..	6
● <b>Preparation –Control Software Install-</b> .....	<b>6</b>
● <b>Programming Procedure</b> .....	<b>7</b>
◆ Operation Flow .....	7
◆ Control Software Open .....	7
◆ Parameters .....	8
◆ File Loading .....	9
◆ Execute programming .....	10
◆ Ending Control Software Operation .....	10
◆ Programming GENERIC group MCU in common boot .....	10
◆ Programming Expanded Memory of ROM-less MCU .....	10
◆ About programming onto R8C,M16C,R32C,M32C series .....	12
◆ Writing restriction by on-chip oscillator of R8C group .....	13
◆ About programming onto V850 series .....	13
◆ Command line option .....	14
● <b>Dealing with Errors</b> .....	<b>15</b>
◆ Error Message Table - F2WinV2- .....	15
◆ LED Status of FLASH2 and Trouble Shootings .....	16
◆ Timing chart of boot mode control .....	17
● <b>Correspondence MCU</b> .....	<b>18</b>
● <b>Version upgrade</b> .....	<b>18</b>
● <b>Optional items</b> .....	<b>18</b>
● <b>Includes</b> .....	<b>18</b>

FLASH2 control software requires Windows95, Windows98, WindowsMe, WindowsNT, Windows2000, WindowsXP, WindowsVista, Windows7 & Windows8.1 Japanese version as OS environment, Microsoft products.

## ● IMPORTANT

### ◆ MATTERS ON SAFETY

**Do not use the FLASH2 before reading this user's manual.**

Make sure that you fully understood this user's manual, before using the **FLASH2** and power adapter.

Reading the manual is the responsibility of the **FLASH2** users to fully understand all the matters.

### ◆ THINGS OF IMPORTANCE

● The **FLASH2** and attached software are products made by HokutoDenshi Co., Ltd.

● The **FLASH2** is to be used by connecting with systems containing the Renesas Electronics made MCU with flash memory built-in microcomputer. The **FLASH2** is not to be used for any other purpose other than that which is specified in the manual.

● **THE FLASH2 MUST NOT BE ALTERED IN ANY CASE.**

HokutoDenshi Co., Ltd. is always improving the product design and performance. These changes will be notified with releases of future product releases.

Users of **FLASH2**: Users only who have fully read and understood the manual should use the **FLASH2**. Users who have not read and not fully understood the manual must not use the **FLASH2**.

● Possession/Ownership/Copyright: The **FLASH2** described in the manual is protected by copyright and this copyright is the property of HokutoDenshi Co., Ltd

● Product Diagrams: There may be cases where a product diagram in the manual differs from the product.

● HokutoDenshi Co., Ltd. has no responsibility for damages and dangers that may come about from incorrect use of the **FLASH2**. All incorrect usage's and subsequent warnings against these usages, that may not have been thought, are the responsibility of the users of **FLASH2** who use the **FLASH2** according to the usage as is specified in the manual.

#### **WARNINGS**

Failure to adhere to the following warnings may result in possible heat, smoke and fire damage to the **FLASH2** and surrounding systems.

1. Don't disconnect and don't reconnect power cables while power is on.
2. Don't remove and don't replace any circuit while power is on.
3. Don't use power voltages other than what is specified in circuit diagram.
4. Be sure to use the correct connector cables when connecting between the **FLASH2**, MCU and peripheral systems.

### ◆ LIMITED GUARANTEE

HokutoDenshi Co., Ltd. guarantees that the **FLASH2** can be used by the usage described in this manual by HokutoDenshi Co., Ltd., and guarantees that the **FLASH2** has been produced correctly and is free of any defects per the products specification. The **FLASH2** is guaranteed for 1 year after purchase of the **FLASH2**.

### ◆ WHAT THIS GUARANTEE DOES NOT INCLUDE

● HokutoDenshi Co., Ltd. guarantees the product only when the product is used correctly as described in the manual. This guarantee is not valid if the product is misused for purposes other than that specified in the manual. The guarantee is valid only for the materials used to construct the product.

● HokutoDenshi Co.,Ltd accepts no responsibility for whatever costs associated directly(or indirectly) with damaged(or faulty) goods.

● This guarantee is valid for only the original purchaser of the product.

For the damages arose cumulatively, when the guarantee explicitly covers the damages, the guarantee is limited to received value of the product price no matter what the reasons are.

Any application for retailing the product by a third party cannot be accepted. The purchaser of the product assumes all responsibility after the **FLASH2** purchase.

This guarantee is not valid in the following cases.

1. Fire, earthquake, flood, an accident caused by a third party, etc.
2. Incorrect use, misuse, abuses user mistake and / or use in an improper environment.
3. The product has been altered in any way or tampered with.
4. The method of use has resulted in damage to the product, or a defect with the product.

## ● FLASH2 Features

We would like to thank you for the purchase of our on-board programmer **FLASH2**.

This **FLASH2** has been designed for the on-board programming of Renesas Electronics's Flash memory MCU enhanced Microcomputer. **FLASH2** circuit management at programming to flash memory is fully automated. Programming to the target MCU from the user's PC can be carried out smoothly without switch operation.

Only upgrading the control software, **FLASH2** can adapt to every new single power supply MCU of Flash memory MCU, releasing one after another. And more, its convenience reaches to the expanded flash memory of ROM-less MCU. The enclosed sample programs provide the easy way of programming confirmation with the LED blinking on the boards **HSB series**, of our products. We recommend smart choice of using **HSB** as your target.

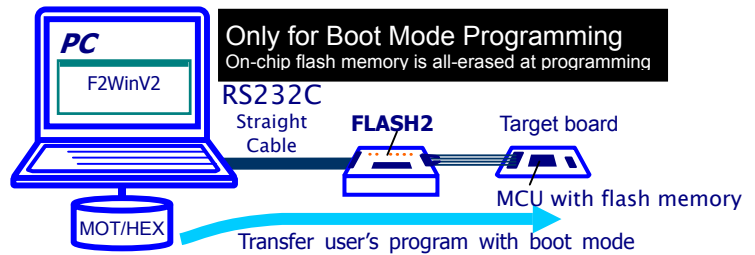

## ◆ Product and contained accessories

Package size **212 × 277 × 62 mm**

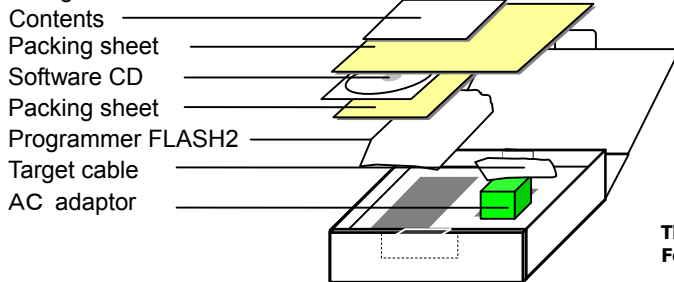

**This AC adaptor is restricted only for Japanese domestic use. For direct shipping abroad, AC adaptor is taken off for safety.**

\* Instruction manual (how to use) and Information book is supposed to be recorded in an attached CD from Mar.05.2008.

## ◆ The provided CD includes

**English For English OS**

- DEMO Demonstration(Categorized by HSB)
- Fmwr Program Expanded memory
- MANUAL Manual (English PDF manual) and The list of supported flash memory MCU(PDF)
- FLASH2.msi
- Flash2V2.msi
- InstMsiA.exe
- InstMsiW.exe
- setup.exe ← **Double click (When using in English)**
- setup.ini

**Japanese For Japanese OS**

- DEMO Demonstration(Categorized by HSB)
- Fmwr Program Expanded memory
- MANUAL Manual(Japanese PDF manual) and The list of supported flash memory MCU(PDF)
- FLASH2.msi
- Flash2V2.msi
- InstMsiA.exe
- InstMsiW.exe
- setup.exe ← **Double click (When using in Japanese)**
- setup.ini

**About Demonstration Program**

In the demo folder, there are LED's blinking programs with reference sources. MOT/HEX file among them is realized quick evaluation of each board.

## ◆ Specifications

**MCU available:** Renesas Electronics's Flash memory MCU of single power supply and Expanded memory of H8SX/1650 and H8SX/1651.  
 See the available type name list at the end.  
 \* MCU that appears in this document is the flash memory edition. (H8SX/1650, H8SX/1651 group is excluded.)

**PC interface:** RS232C-serial-port (the straight cable is required for the connection.)  
 The DUSB 25 pins socket is equipped as the programmer's PC interface connector.  
 See the note in the "User's Guide" about the connection in the straight cable.

**Power Supply:** AC adapter (DC9V) or 2 alkaline drycells (LR6/1.5 volt)

The provided AC adapter is verified for Japanese domestic use only.

Specifications of AC adapter

Input

Voltage : AC100~240V

Frequency : 50~60Hz Electric current: Under 300mA

Output

Voltage : DC9V

Maximum electric current : 1.33A

Jack

Form : Center-minus

Dimension : Outside diameter  $\phi$  5.5mm / Inside diameter  $\phi$  2.0mm

In use with drycells, we recommend to exchange the drycells in every 1 hour for successively programming.

**Programming Voltage:** 5V or 3.3V (depend on "VIN", that is target Vcc power supply to Interface 20<sup>th</sup>)

**PC available:** F2WinV2: Windows95, 98, Me, NT, 2000, XP, Vista, 7 and 8.1  
 Japanese version - Some types are not available -

**Body Case Size:** 89 mm × 134 mm × 36 mm

**Weight:** 180g (without drycells)

**Operating conditions**

Programmer Operating Temperature	0°C~+40°C, less than 80%RH without bedewing
*Confirmed Operating Temperature	with ACadapter -10°C~+50°C
	with drycells +10°C~+50°C depends on the cell spec
AC adapter Operating Temperature	0°C~+40°C
Storage Temperature	-25°C~+60°C, less than 80%RH without bedewing

Package Seal and Products Serial Number

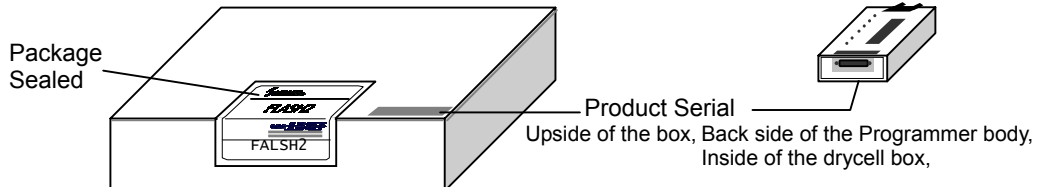

◆ **Parts Name**

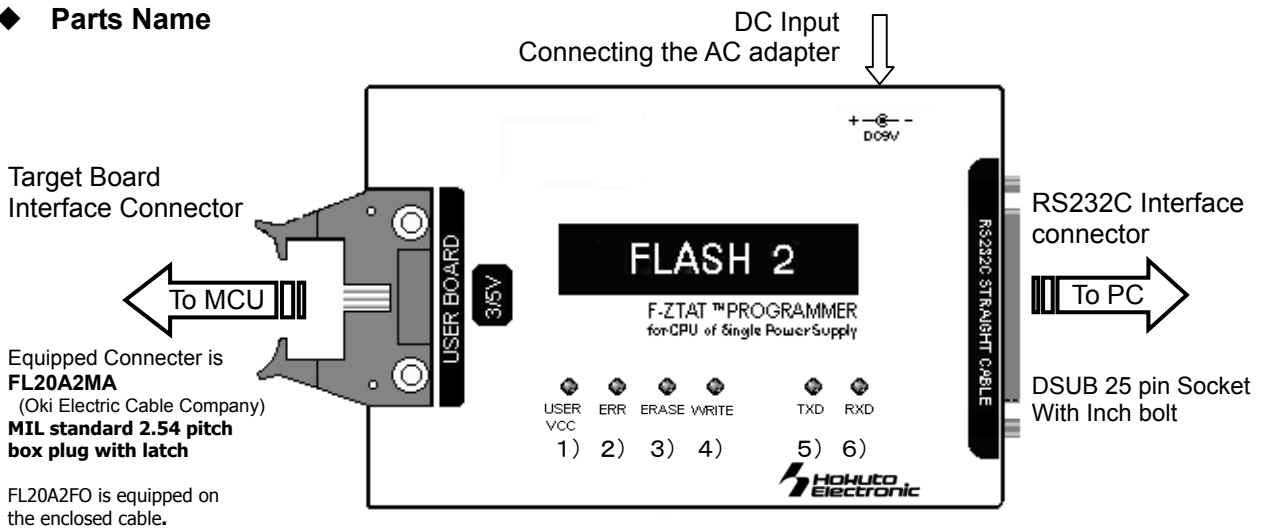

Equipped Connector is **FL20A2MA**  
(Oki Electric Cable Company)  
**MIL standard 2.54 pitch**  
**box plug with latch**

FL20A2FO is equipped on the enclosed cable.

□ **Explanation of LED Status**

- (1) **USER VCC** The power from the target board supplies to Interface VIN of 20<sup>th</sup> pin as UserVcc.
- (2) **ERR** Error is recognized.
- (3) **ERASE** Target flash-memory is erasing.
- (4) **WRITE** Programming or verifying is executing.
- (5) **TXD** Signal is transporting to host-computer.
- (6) **RXD** Signals is receiving from host-computer.

□ **Battery Holder Guidance**

Please read <Precaution> before placing the batteries into the battery holder.

<**Precaution**>

Some of the alkaline batteries contain flexible insulating label to it. When placing that kind of batteries into the battery holder, negative terminal (-) of the battery holder could come into contact with positive terminal (+) inside of the flexible insulating label as shown in the diagram below. It causes electrical short-circuit.

Please do not use the batteries described above. Electrical short-circuit may cause smoke and fire.

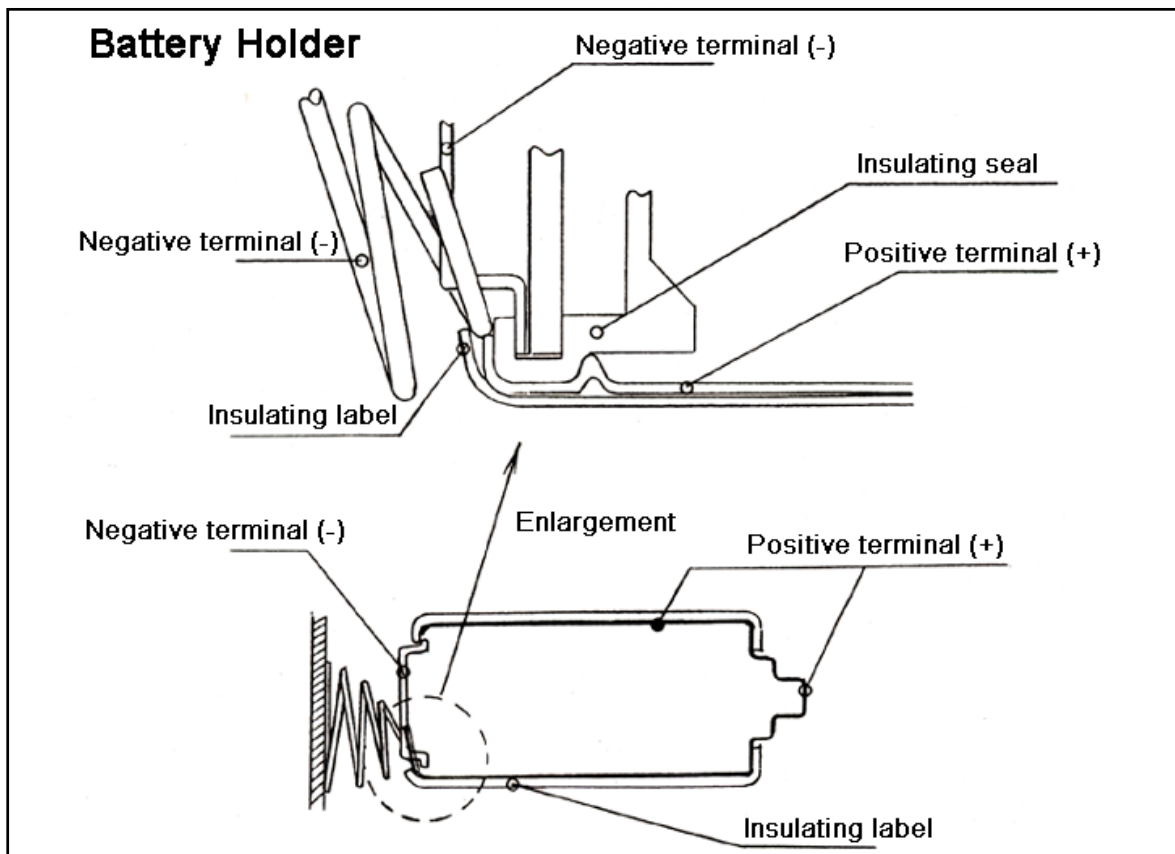

- **FLASH2 Power Operations – Important –**  
**UserVcc LED indicates the status of FLASH2 power on/off. Both 2 dry alkaline cells and AC adapter can be used as a power supply for the FLASH2 itself. And also FLASH2 needs UserVcc from the connected target board. UserVcc LED can light when the both power supply are enough to operate.**

**The Order of Power Supply**

We recommend the procedure below to avoid troubles.

**Power ON: FLASH2 body first, then the target board. -**

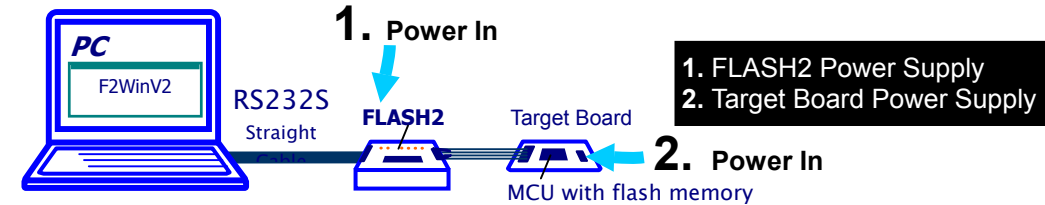

**Power OFF: The target board first, then FLASH2 body -**

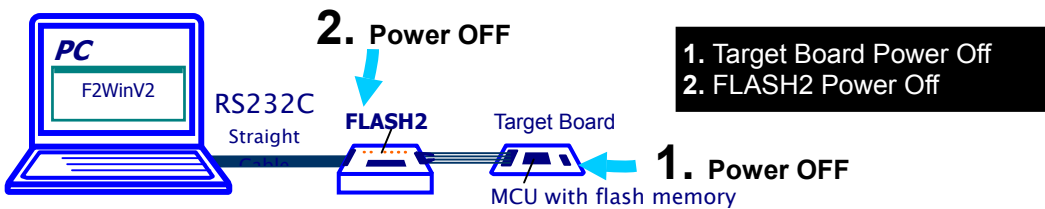

◆ **Connectors & Cables**

Please refer to the “User’s Guide” about the connectors and the signal-names.

◆ **How to Purchase the Upgrading Control Software**

Only upgrading the control software, **FLASH2** can adapt to every new MCU of Flash memory MCU Microcomputers. For the series of single power supply, we present the new version for all Flash memory MCU Microcomputers releasing one after another. In using R8C·M16C series MCU, firmware in the programmer must be updated. (Charged. For further information, see the end of a book.)

If you need your control software to upgrade, please feel free to ask by E-mail.

URL : <http://www.hokutodenshi.co.jp> (Japanese site only) E-mail : [support@hokutodenshi.co.jp](mailto:support@hokutodenshi.co.jp)

## ◆ High Speed Clocked Synchronous Communication of FLASH MATE 5V1

Clocked synchronous mode writing cannot be carried out by FLASH2. Only our FLASH MATE 5V1 can realize the fast transfer in writing. As for FLASH2 and FLASH MATE 5V1 you can choose both solution without modification about connector, signal and reference circuit diagram; these are in common.

### ● Preparation –Control Software Install-

See the PC's Windows manual to install properly for each PC.

Before this install, we recommend closing all the other application as possible, or the install must be uncompleted with the access refusal from the required files. Please be careful that Install failure is sometimes difficult to be recovered.

This page is for  
**Windows95/98**  
**Japanese Environment**  
See about the preliminary monitor version for English environment is described in the other enclosed document.

#### <Procedure>

1. Open the enclosed CD, double click the "setup.exe".

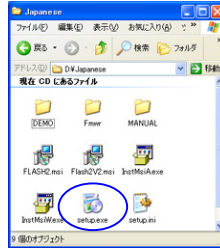

2. The starting dialogue of the installer is appeared, then confirm the message and click the "次へ" (next).  
If the MDAC install message is appeared, see the right guidance to install the MDAC before redo from 1.

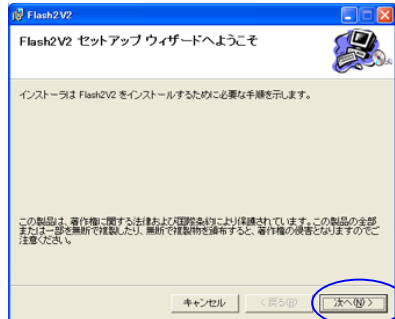

3. In the next dialogue "インストールフォルダの選択" (select install folder), confirm the folder where this F2WinV2 install to. If it is necessary to change the default directory, click the "参照" (refer to) and select the folder as it is needed. The file size information is indicated below. Click the "次へ" (next) to progress.

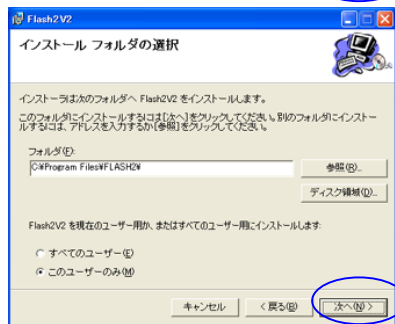

4. In the next dialogue "インストールの確認" (confirm to start), the install will start to click "次へ" (next). The progress is indicated in the dialogue.

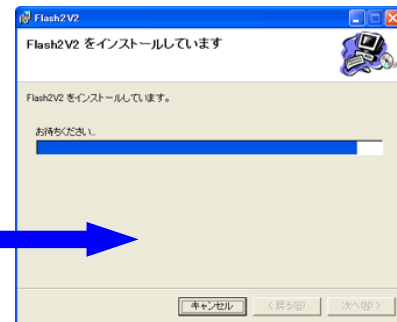
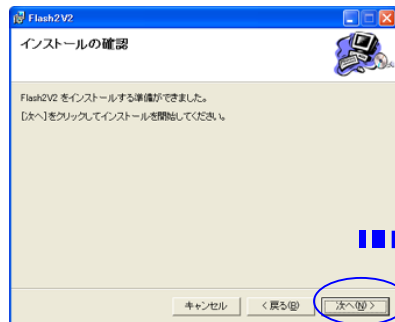

5. The dialogue "インストールが完了しました" (install completed) is the successful complete message, then click the "閉じる" (close the installer) to finish the procedure.  
If there is the message of the PC reset, it is necessary to reset the PC before "F2WinV2" open.

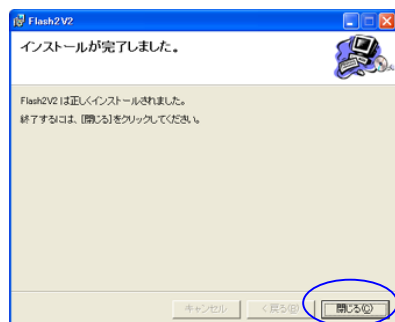

#### **Attention !**

While the install, it is necessary to overwrite the required files, if the message is appeared. "F2WinV2" needs all the required files to execute properly. Please be careful about the overwrite influence for your present environment.

If you have questions, our support desk is [Support@hokutodenshi.co.jp](mailto:Support@hokutodenshi.co.jp).

## ● Programming Procedure

### ◆ Operation Flow

See the following operation flow. In this section, the rest 4 to 8 are explained.

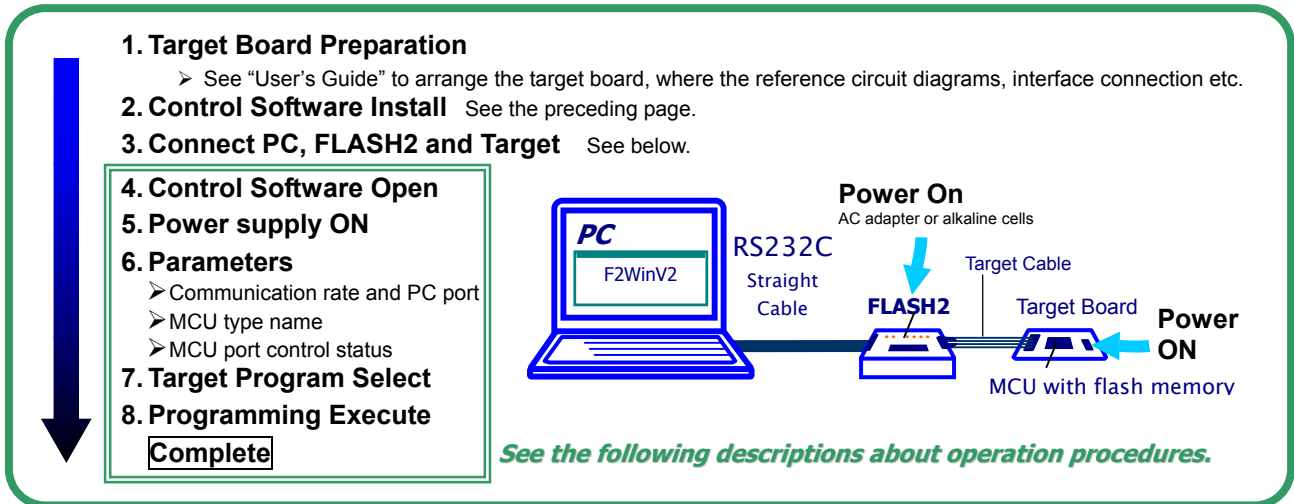

### ◆ Control Software Open

At first, let's open the installed control software "F2WinV2". It can be started to click the name from the pull-up menu "start" button at the left bottom of the corner, from "program" -> "HokutoDenshi" -> "F2WinV2" then application window is opened like below.

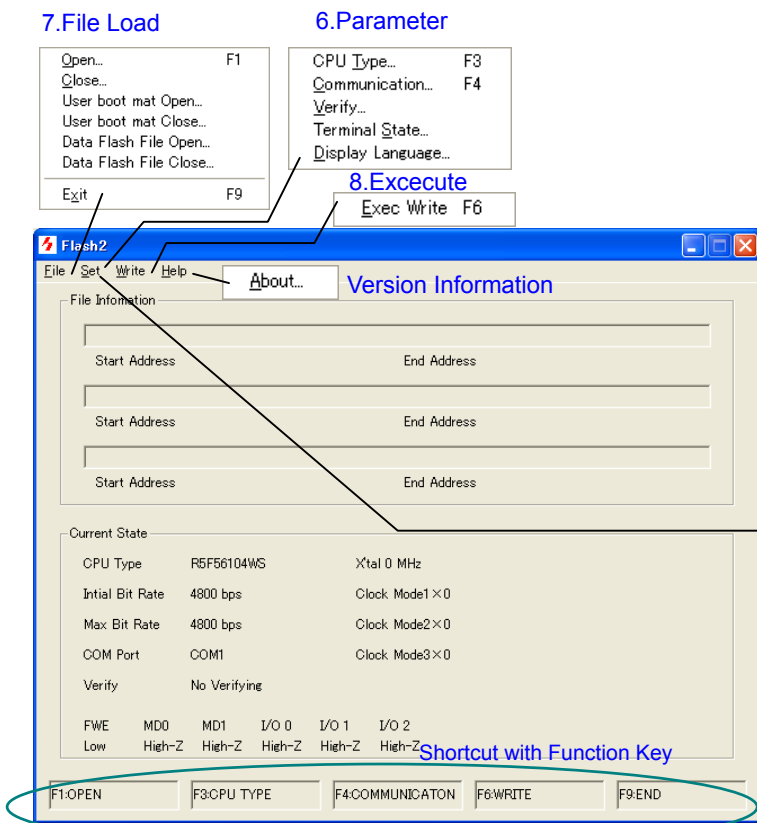

File-loading can not be done without the MCU type name selecting. At the file loading, the data address is examined with the selected MCU type name. If MCU type name is need to change, close the loaded file at first.

When this control software is closed, all the parameters are save in the system folder "¥windows" as the file name is "FLASH2.INI". The control software must be damaged if the initial file "FLASH2.INI" is moved or delete, while the control software is opened.

The file box for the third area is indicated only when it is necessary. One box of the upper step is indicated with the usual MCU.

**Language select** dialogue is in the "Display Language" in the menu of "Set."



The shortcuts assignments for function keys are always indicated on the status-bar and in the pull down menu.

#### □ Display Language

At the first open of "F2WinV2", the display language confirmation is appeared automatically. Select from English and Japanese. The selected language can be changed to click the "Other" in the "Set" menu.

#### □ Power On

To start the operation, FLASH2 power status must be checked, that is indicated with the UserVCC LED on the programmer body. It is necessary to supply both power into programmer itself with AC adapter or alkaline dry cells and with UserVcc from the target. Be careful about the User Vcc voltage steady and properly. It is important because the FLASH2 uses it as programming voltage to the MCU.



## ◆ Parameters

All the parameters must be selected properly that are described following. These parameters are in the “Set” menu of the menu bar.

### □ MCU Group & Type Name

Short Cut Key: F3

Select the group at first, then the type name of the target MCU. It is incapable to program that are not listed here. Be careful about the confusing musk type.

The input dialogue of the target board clock frequency is appeared, if it is necessary. The frequency input must be until 200MHz, and also the required CMK is fixed like the following example. Especially, The MCU in Generic group can be programmed with common boot control program. Please confirm the proper CMK according to the Hard ware Manual of the target MCU.

**SH7058** 4 2 X (System 4 Peripheral 2)  
**H8/3069RF** 1 X X (No Multiplied)

When the **H8SX/1650** is selected, writing control program select box appears soon. For this ROM-less MCU, it is necessary to prepare the proper writing control program in MOT/HEX file format according to the user's expanded FLASH memory.

See “Programming Expanded Memory of ROM-less MCU” about the programming control program.

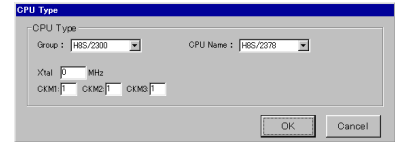
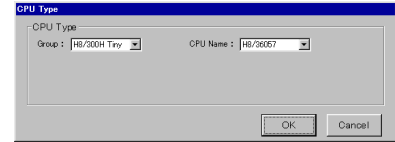

In the case of H8SX/1650



### □ Communications

Short Cut Key: F4

#### Transfer Rate at the start

The initial transfer rate at the beginning of the handshake with the MCU. It is important to select the proper rate that is described in the each MCU hardware manual.

#### Maximum Transfer Rate

After transfer the programming control program, FLASH2 raise the rate until the maximum in the environment. As the target board clock, we recommend the serial communication error rate below 0.16. See the bit rate register descriptions in the MCU hardware manual of the chapter about “Serial Communications”. The communication between PC and FLASH2 are ordinary realized 38400 bps at the maximum, even if the parameters set at 76800 bps. If the communication error often occurs after the erase, we recommend examining the other combination of the initial rate and maximum rate. In using R8C·M16C series, a transfer rate should be fixed at 9600 bps, and 76800 bps, the maximum transfer rate, cannot be selected.

#### COM Port

Select the port of your environments. **USB port with RS232C converter** is not supported with FLASH2. It is not enable to communicate properly with some USB to RS232C converter.

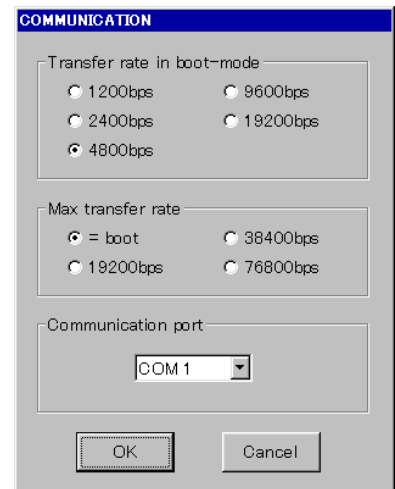

### □ Terminal Status

To control the connected MD port or FWE port into the boot mode, select the required status from the dialogue.

#### Operating Mode and Ports States

The target board must be prepared in the proper Operating Mode to execute the user program. FLASH2 executes the reset-start automatically to run the user program just after completion of programming.

The other side, specified port must be controlled in proper level, High or Low, for starting the boot mode. The reference circuit diagrams indicate one idea to start boot mode with control by FLASH2. User can arrange mode ports in FLASH2 control software with selecting the button in the Terminal State window. If user would like to manage into boot mode before the operation with the own idea, those ports do not have to connect with FLASH2. Refer to the advices for arrangements in “User's Guide”. HSB series \*; the MCU boards series of Hokuto products.



Number at the Interface Connector (20Pin)

**Verify**

The optional verify can be selected in this menu.

This verify is started after programming complete. The data transfer to PC and compare with the loaded file data. This verify is different from the Hitachi Flash memory MCU on-board programming ordinary flow. The prescribed verify in programming is done without select this verify. The result must be used by the user's own decisions.

It is recommended to do Verify to enhance the reliability of the programming.

**No Optional Verify**

Only in programming, data is verified in prescribed byte unit.

**Comparing by check sum**

After programming, data is verified by check sum. Note) Check sum is the lowest digit of every data summation in all the flash memory. If 2 files are selected, check sum are showed in each. In the use of R8C series MCU, Comparing by check sum cannot be selected.

**Comparing by byte unit.**

After programming, data is verified by byte unit.

Because, at the beginning of the boot mode, the on-chip ROM is all-erased automatically, it is impossible to verify without programming.

Check the box if programming log file is required.

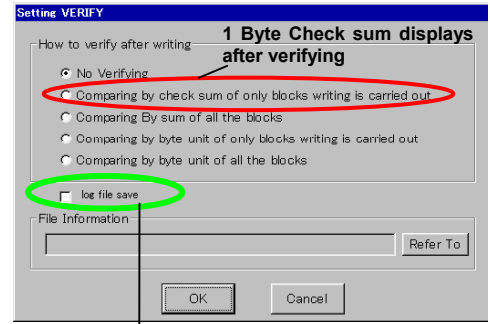

**Programming Log File**

The file format is text at default with extension is ".log" if there is no description in the file information box.

**Programming Log File**

**Display Language**

Select the display language from Japanese and English

All the parameters are saved when the control software are closed.

**File Loading**

**Open/Close**

To load the file for programming, select "Open" from the pull down menu in "File". The MOT/HEX file must be named ".MOT/HEX" as its extension.

We recommend loading the file after the MCU setting. Close the file before changing the MCU type.

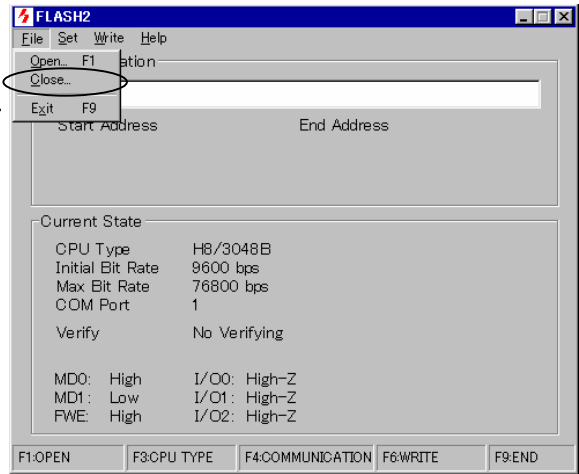
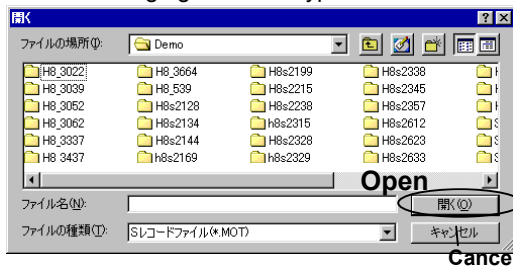

The demo programs in the enclosed CD are useful as the sample MOT/HEX files. Please copy from the CD if you need.

If the date address error of the loaded program is indicated at the file load, we recommend to examining the programs not to fail in the generation with the proper link, confusing with RAM address etc. In the on-board programming, the user programs transfer into on-chip ROM only.

**Secondary file**

Some MCU have secondary mat in its on-chip ROM like "user boot mat" of H8/3069F. If the MCU type is selected from MCU list that can be able to use secondary mat, "User boot mat Open/Close" and secondary file box will be automatically appeared.

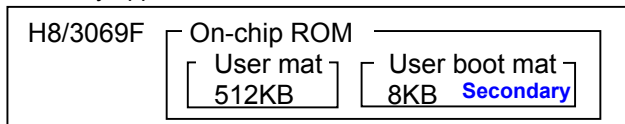

For each mat, the program must be arranged form the begging.

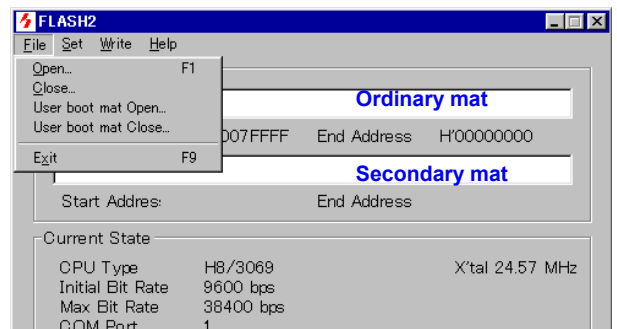

**Third file**

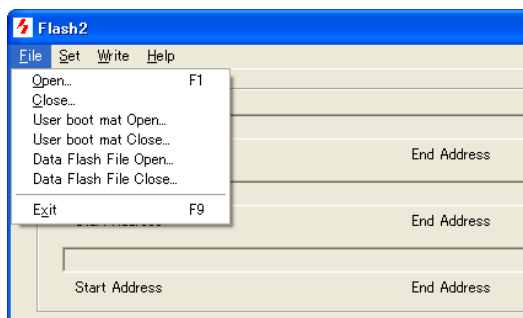

When the MCU which has the user boot mat and the date flash was selected, the file menu and the file information box is indicated as follows.

## ◆ Execute programming

All the settings and the file loading are completed, and then choose “Exec Write” from pull down menu of “Write”.

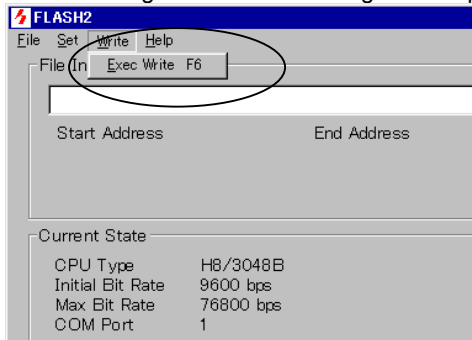

The progress bar indicates programming.

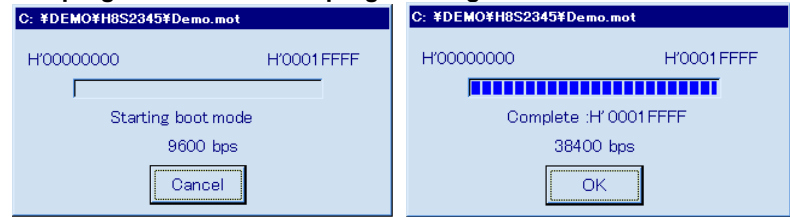

If MOT/HEX file does not have “.MOT/HEX“ as its file name extension, a different address is appeared at the progress indicator. If MOT/HEX file format is correct, it can be renamed in its extension to “.MOT/HEX”.

## ◆ Ending Control Software Operation

Select “exit” from “File” in menu bar.

\* All the parameters are saved at closing the control software.

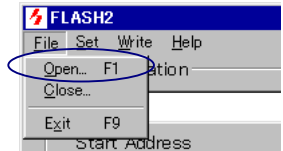

## ◆ Programming GENERIC group MCU in common boot

All the 0.18 μFlash memory MCU have the common boot control program called “GENERIC Boot”. FLASH2 supports this programming as in the “GENERIC” group. When the GENERIC as its type name in the GENERIC group is selected, the programming is controlled with common boot program for all the GENERIC MCU. At the MCU selecting, the automatically appeared CMK input boxes must be filled as the proper value, according to the Hardware Manual of the MCU. The examined MCU's are added in the Type Name pull-down list, following “GENERIC”. The unlisted MCU of the 0.18 μFlash memory MCU are controlled with the common boot program specified with the Renesas Technology. Be careful about the address in the program, because the data to the wrong address that exist out of the internal flash ROM are all ignored at the programming without warning.

### □ Restrictions and Advices for GENERIC group

- For the CMK input boxes, it is necessary to set the proper numbers as the target clock frequency with according to its Renesas Electronics Hardware Manual descriptions. Be careful for H8S/2172F, the input value must be doubled of the mounted target clock frequency. For the other examples, SH7058 and H8/3069F are set like following;

SH7058	CMK1: 4	CMK2:2	CMK3:Don't Care
H8/3069F	CMK1: 1	CMK2: Don't Care	CMK3:Don't Care

- The following attention is necessary for GENERIC group MCU.

The calculation of checksum is  $8\text{Kbyt} \times 2^n$  ( $n=0,1,2,\dots$ ). When the ROM size of the MCU doesn't arrive at the regulation size, checksum is calculated in the big size fitted to the regulation size. All the data on the area which doesn't exist are 0xFF.

## ◆ Programming Expanded Memory of ROM-less MCU

FLASH2 can program the expanded memory of the following ROM- less MCU.

**Available MCU Type** H8SX/1650, H8SX/1651

**Specified Expanded ROM** MBM29LV800BA-70 (Fujitsu) or equivalents

\*TC58FVM5T2AFT-65(TOSHIBA), S29GL032M90TFIR4 (SPANSION) finished the confirmation

**Restrictions**

To change the programming control program, it is ness carry from the file loading.  
The programming control program must be addressed appropriately like following.

MCU Type Name	Base Address	User program area
H8SX/1650	FF6800h	FF6800h~FFBFFFh
H8SX/1651		

Base Address+0h	~+3h	Top of the flash memory (put 0 into here)
Base Address+4h	~+7h	Bottom of the flash memory (put the last address into here)
Base Address+8h	~+Fh	Version of the programming control program
Base Address+10h		"write_init" routine
Base Address+100h		"write_flash" routine

- The programming control program must be differed appropriately according to the flash memory expanded of the MCU.
- If the flash memory is different from the specified one, it is able to generate the appropriate MOT/HEX file from the source recompiling in the FMWR folders with rearranging the tables and so on.
- For the specified flash memory above, there is appropriate MOT/HEX file as a content of this product.
- Make sure that writing in the program expanded memory of ROMless MCU should be up to 1MB.
- Please feel free to ask more information about the minute specifications for the other types expanded memories. And we can provide the MOT/HEX file for the different flash memory. But we can't support the user's original programming control program.

### Programming

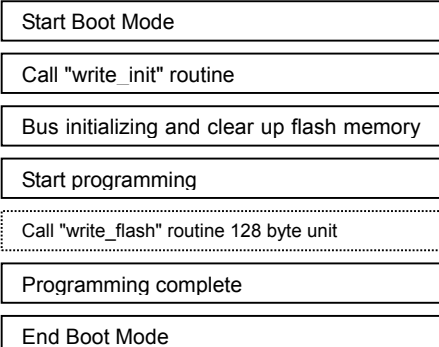

Each routine is contained in the MCU type named folder of the enclosed CD, with its source files. See the directory descriptions below.

## Programming procedure

It is the same steps to program the memory except selecting the programming control program.

1. **Open the control software, F2WinV2.**  
Click twice the icon of F2WinV2.
2. **Select the MCU type name “H8SX/1650” or “H8SX/1650” from the list.**

From “MCU Type” in the menu of “Set”, select “H8SX/1650” in the pull-down list. Instantly the pull-down box appears next to it, to select the MOT/HEX file of the programming control program. All the MOT/HEX files in the specified folder described below are listed in the pull-down list.

3. **Select the transfer rate.**  
Both initial rate at the beginning of boot mode and maximum rate to transfer the user's program must be appropriately selected.
4. **Select the port status.**  
According to the connections of the interface, select the buttons in the port status window to control the target boot mode.
5. **Check the option flags.**  
It is able to set the options, auto erase, fast boot and erase check. The optional verifies can be selected here.
6. **Load the target file.**
7. **Click “Exec Write” from the menu of “Write”.**

### Attention !

The execution of programming must be clicked after selecting the programming control program. To start programming without selecting the program can't be guaranteed.

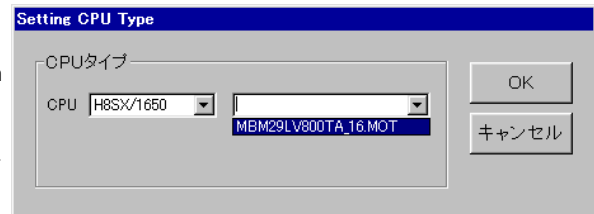

### The Directory for the Original Programming Control Program

The programming control program can't be selected, if the MOT/HEX file doesn't exist in the appropriate folders like in the right description.

Ex. C:\Program Files\FLASH 2\FMWR\H8Sx1650\

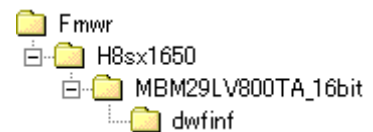

### The interface of the target board

See the description in H8SX/1650 in the User's Guide.



## ◆ About programming onto R8C,M16C,R32C,M32C series

It's possible to program onto devices ( shown as below ) with an optional conversion unit.

Format···MOT/HEX

new elements will be added.

### 【Outlines of each unit】 (R8C/M16C Series, R8C Series)

Cable Name	20-<->10pin FoUSB*1	20-14pin R8C*2	20-14pin M16C*1
Conversion unit	20<->10pin FoUSB 	20<->14pin R8C 	20<->14pin M16C 
Included	10pins straight cable is attached	14pins straight cable is attached	14pins straight cable is attached
Specification	Connecting to USB Writer and M16C Flash Starter*3	Connecting to Emulator E8a *4	Connecting to Emulator E8a *4
Group of supported MCU	R8C/10~13, R8C/18,19,1A,1B R8C/20~29 R8C/2A,2B,2C,2D R8C/2E,2F,2K,2L R8C/32A,32C,32D,32G,32H R8C/32M,33A,33C,33D,33G R8C/33H,33M,33T,34C,34E R8C/34F,34G,34H,34K,34M R8C/34P,34R,34U,34W,34X R8C/34Y,34Z,35A,35C R8C/35D,35M,36A,36E,36F R8C/36G,36H,36M,36W,36X R8C/36Y,36Z,38A,38C R8C/38E,38F,38G,38H,38M R8C/38W,38X,38Y,38Z R8C/3GA,3GC,3GD R8C/3JA,3JC,3JT R8C/3MK,3MU,3MQ R8C/36T-A R8C/54E,54F,54G,54H R8C/56E,56F,56G,56H R8C/L35A,L35B,L35C,L35M R8C/L36A,L36B,L36C,L36M R8C/L38A,L38B,L38C,L38M R8C/L3AA,L3AB,L3AC,L3AM R8C/LA3A,LA5A,LA6A,LA8A R8C/LAPS R8C/M11A,M12A,M13B M16C/26,26A,28,29,1N M16C/30P,57,5M,5L M16C/62P,62A,62N,62M M16C/63,64,64A,65 M32C/83,84,85,86,87 R32C/116,118,120,121 R32C/152,153,156	R8C/10~13	M16C/26,26A,28,29,1N M16C/30P,57,5M,5L M16C/62P,62A,62N,62M M16C/63,64,64A,65 M32C/83,84,85,86,87
Price	¥2,000	¥2,000	¥2,000

#### Notes:

\*1 Please connect "mode pin of R8C/14~17" to GND on the board side, to use "20<->10Pin FoUSB" and "20<->14Pin m16c" converter.

\*2 Please output TX and RX to program.

\*3 Please refer to MCU hardware manual for examples of connection Serial Programmer and MCU.

\*4 Please refer to "E8a Emulator user's manual" for this pin assign.

Please use programming tools with appropriate version of control software.  
Please refer to the instruction manual for each connection on the target board.

**[Outlines of each unit] (RX, 740 Series)**

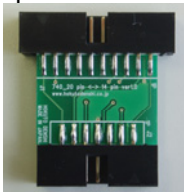
Cable Name	20-14pin RX	20-14pin 740
Conversion unit	20<->14pin RX 	20<->14pin 740 
Included	14pins straight cable is attached	14pins straight cable is attached
Specification	Connecting to Emulator E1 and E20*5	Connecting to Emulator E8a *4
Group of supported MCU	RX111 RX210,21A,220 RX621,62N,62T,62G,63T RX630,631	740/3803,38D5
Price	¥2,000	¥2,000

**Notes:**

\*4 Please refer to “E8a Emulator user’s manual” for this pin assign.

\*5 Please refer to “E1 Emulator user’s manual” or “E20 Emulator user’s manual” for this pin assign.

Please use programming tools with appropriate version of control software.  
Please refer to the instruction manual for each connection on the target board.

**how to connect**

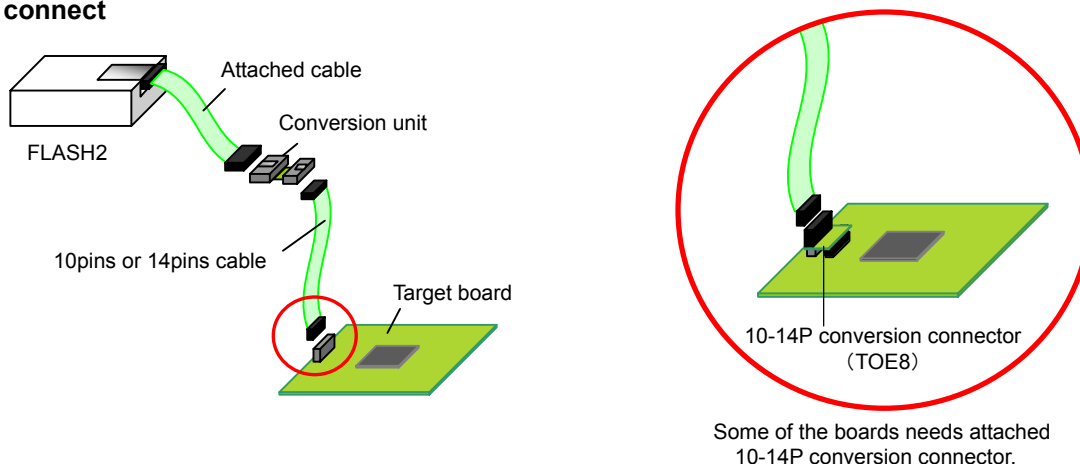

**◆ Writing restriction by on-chip oscillator of R8C group**

- The following items of MCU group cannot be written by an on-chip oscillator:
  - R8C10、R8C11、R8C12、R8C13、R8C18、R8C19、R8C1A、R8C1B、R8C20、R8C21、R8C22、R8C23、R8C24、R8C25、R8C26、R8C27、R8C28、R8C29、R8C2A、R8C2B、R8C2C、R8C2D、R8C2E、R8C2F

**◆ About programming onto V850 series**

It’s possible to program onto devices ( shown as below ) with an optional conversion unit.  
In connecting with the recommendation circuit of each series, the following conversion units are necessary.

Format···MOT/HEX

new elements will be added.

**[Outlines of each unit] (V850 Series)**

Cable Name	20-16pin V850
Conversion unit	20<->16pin V850
Included	—
Group of supported MCU	V850ES/Jx2,Jx3-L V850E/Ix3
Price	¥2,000

**how to connect (conversion unit only)**

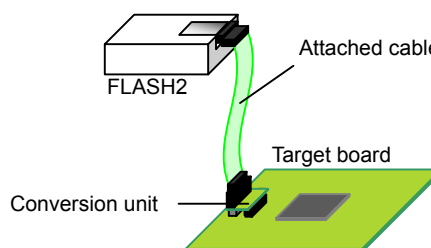

Please use "F2WinV2" for control software.

◆ **Command line option**

When the FLASH2 starts, programming can be done in the command line. The form is as follows.  
 <path>F2Win.exe Δ Option1 Δ Option2 (Δ=space)

Option1: The name of the programming file to set in the primary area.  
 Option2: The name of the programming file to set in the secondary area.

※ Parameter should be full path.

The setup of variety in the control software is necessary to use the command line option.

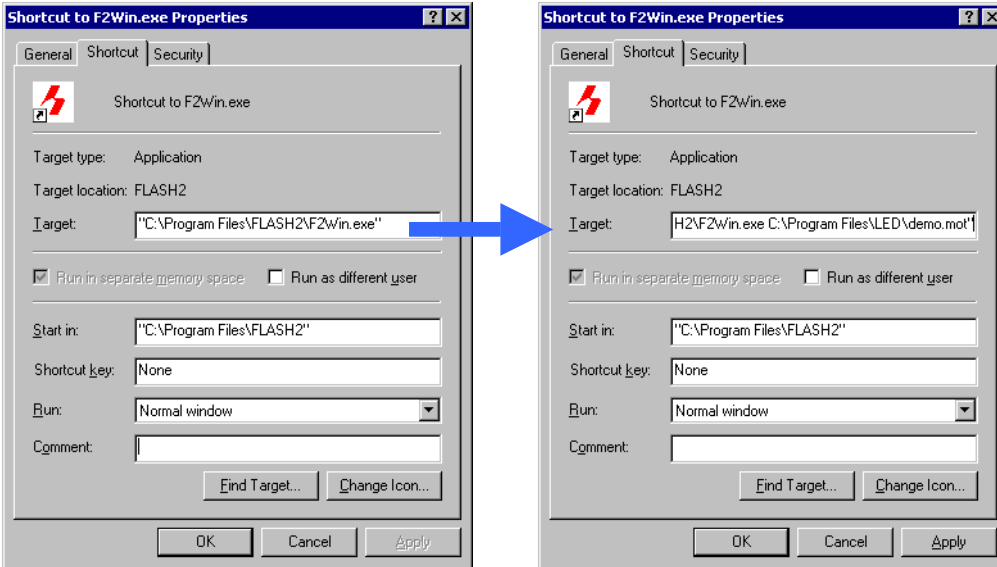

Note: F2WinV2 has supportses command line option after the version.2.1.1.0.  
 Please do the designation of the file referring to the following example.

<path>"C:/Program Δ Files/FLASH2/F2WinV2.exe" Δ " Δ -o1=XXXX Δ -o2=YYYY Δ -o3=ZZZZ Δ -e"

The definition of F2WinV2

User Mat	-o1=XXXX
User Boot Mat	-o2=YYYY
Data Flash	-o3=ZZZZ
No error output	-e

(Δ= space, XXXX,YYYY,ZZZZ=MOT/HEX file name)

## ● Dealing with Errors

### ◆ Error Message Table - F2WinV2-

F2WinV2 Error#	Message	
#0	COMポートがありません。	Nothing Com Port.
#1	メモリが足りません。	Memory Shortage.
#2	ファイルの形式が異常です。	Illegal File format.
#3	通信ポートを開けません。ポートの設定を変更してください。	Can't open port. (Check the port select)
#4	書き込み制御プログラムが異常です。	Invalid write control program.
#5	ファイルが選択されていません。	File is not selected.
#6	ブートモードの起動に失敗しました。	Can't start in the boot mode.
#7	フラッシュメモリの消去に失敗しました。	Can't Erase Flash memory.
#8	ビットレートの最適化に失敗しました。	Failure to optimize the bit rate.
#9	フラッシュメモリの書き込みに失敗しました。	Failure to writing memory.
#10	バリファイエラー。	Verify error.
#13	通信エラーが発生しました。	Communication error. FLASH2←→Target MCU
	通信エラーが発生しました。	Communication error. PC←→FLASH2
#20	エラー（上記以外のエラーです）	Error. (Unexpected error occurred.)
#14	ボーレート設定失敗	Failure to setting baud rate
#15	ID照合失敗	Failure to ID checking
#19	ファームウェアが古い為実行不可	Due to the old-fashioned firmware, writing is not possible.
#12	処理を中断しました。	User Break.

#### Note 1:

FLASH2 is not guaranteed to the correct processing with other appreciations. Especially, the conflict at the transmission processing will be brought the communication errors. Communication error will be also occurred when more than one FLASH2 are started at the same time, because time out error will be caused in waiting for the others' processing.





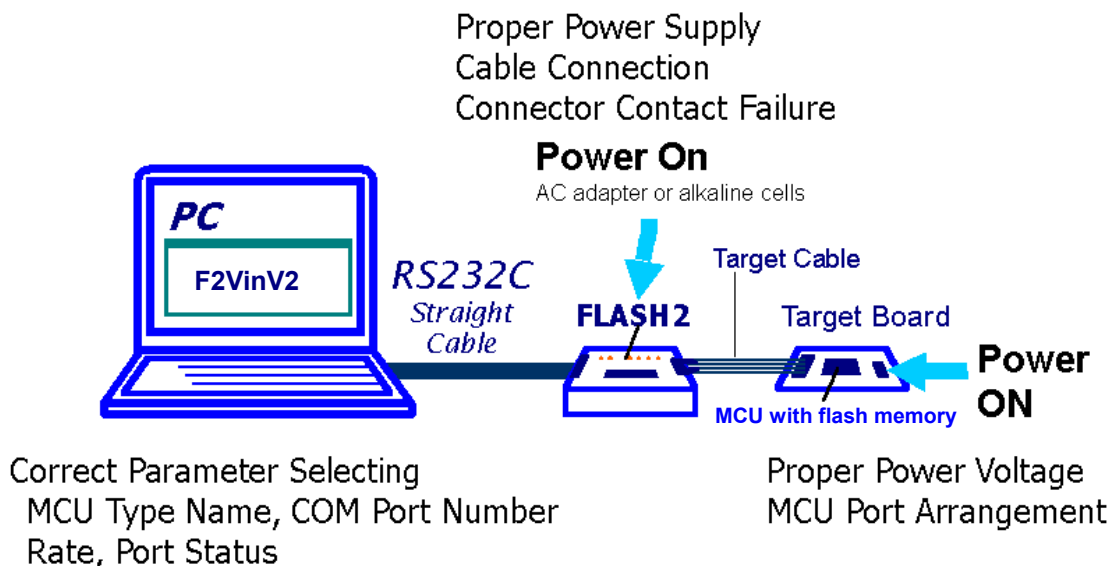

#### Note 2:

In the same situation of the target board, cables and PC, if FLASH2 often have error #6 but sometimes success, we recommend to examine the status of supplied power voltage, or miss-arrangement of required MCU port. See the User's Guide of the arrangement about the proper reference circuit diagrams for the target board. The serial communication error also occurs with depending on the target board clock frequency. In the other case that the error number is not specified, cable's disconnection or connector contact failure must be examined, too.

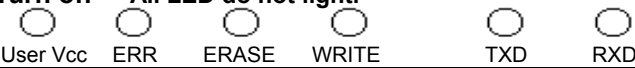
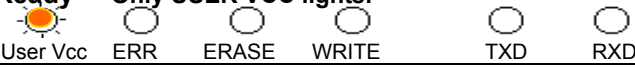

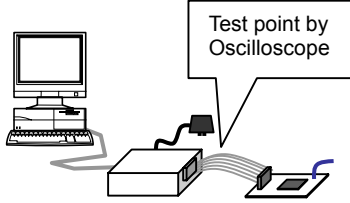

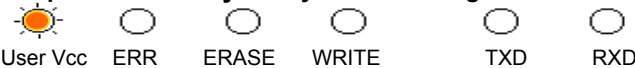
## ◆ LED Status of FLASH2 and Trouble Shootings

Programming Flow	LED Status and Frequently Occurred Troubles
<b>Connection and Power on</b> DC supply into FLASH2, then Target board power on.	<b>Turn off →All LED do not light.</b> 
	<b>Ready →Only USER VCC lights.</b> 
<b>Start of Writing</b> Click <b>Start</b> or push <b>F6</b>	<b>‡UserVcc LED does not light.</b> <b>Check Power supply to FLASH2 and the target board.</b> Especially, be careful about the dry cell's power level. We recommend the new ones to ensure the writing.
<b>Starting boot mode</b> ↓ Bit rate adjusting, and erasing all data	<b>→USER VCC, ERASE and WRITE light. TXD and RXD are blinking.</b>  <p>‡<b>"#6 Can't start in the boot mode."</b> is appeared, and stopped.</p> <p><b>No signal reached the target MCU.</b>            Communications are disturbed by RS232C cable misuse/breaking/contact failure, or FLASH2 breakdown. Sometimes Windows operations have some troubles in its environment. Check the RS232C cable, and also check the signals correctly transferring from the FLASH2_17 and controlling of 1/3/5/7/9/11/13 at its target interface. If some signals are uncontrolled correctly, error must be occurred before FLASH2 output.</p>  <p><b>No answer from the target MCU.</b>            In spite of the correct communications from FLASH2, the target MCU makes no reply. Check the circuit around the MCU in writing, especially the port MD/FWE/RESET and SCI port are controlled correctly. Sometimes, Xtal oscillation failures influence in transferring.</p> <p>‡<b>#6 Some Error occurred in progress.</b>            As acceptable transmission error ratio in serial communications, less than 0.16 is recommended. If transmission is successes on border at first, error can be occurred in progress. Unsoldered MCU pins or program reset like "WDT" also disturb transmission progress.</p> <p>‡<b>"#7 Can't Erase Flash memory."</b> is appeared, and stopped.            MCU does not reply correct H'AA, although the first part of transmission is succeeded. Check the correct MCU type name is selected, communication Failure by noise or Xtal oscillation failures. Transferring rate combination change is sometimes effective. Unsoldered MCU pins or program reset like "WDT" also disturb transmission progress.</p>
<b>On writing</b> ↓ Bit rate optimizing at maximum rate. Transferring user program in prescribed block size and compare.  (Verifying in option)	<b>→USER VCC and WRITE light. TXD and RXD are blinking.</b>  <p>‡<b>Communications Errors are often occurred.</b>            Communication state is influenced by cable breaking/defects/misuse. The cable length for the target cable is guaranteed in the attached one, 30 cm in max. Power supply is also important, especially in the case of the dry cells. Check the voltage and the UserVcc LED status. When transmissions failure is often occurred in specified address, check the port status of the target to examine the wandering in processing.</p> <p>‡<b>Optional Verify is failed.</b>            Guaranteed programming by Hitachi is finished except this optional verify. Optional verify is sometimes omit the correct ones.</p>
<b>Completing of writing</b>	<b>Completed correctly→Only USER VCC lights.</b> 
<b>Error occurred</b> ※ERR LED does not distinguish until starting next writing.	<b>→USER VCC and ERR light.</b> 

◆ Timing chart of boot mode control

<<At Start>>

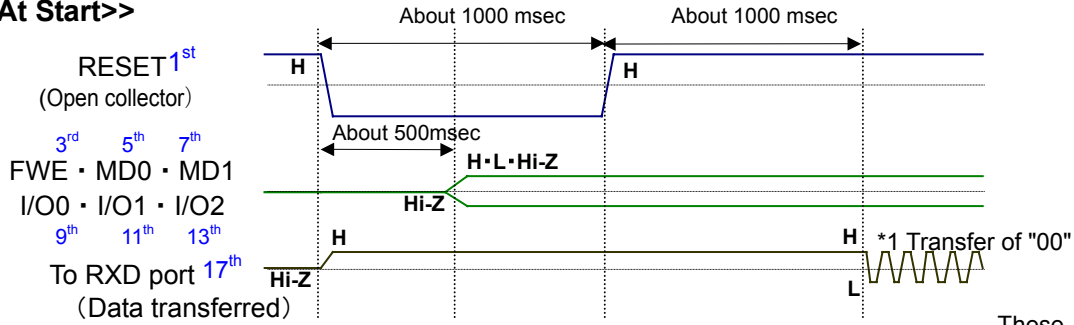

\*1 From the 17<sup>th</sup> line of the interface transfer of "00" is repeated within the 512 times limit until reply from the target. When nothing reply from the target MCU at the 15<sup>th</sup> line of the interface, the job is canceled as an error.

These escriptions are outline, refer to the Renesas Electronics hardware manual in detail.

<<At Ending>>

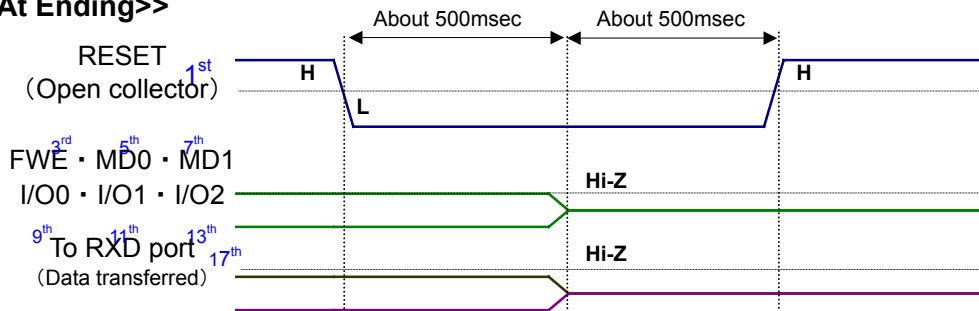

MCU clock displayed in operation of writing is the estimated value from transfer rate etc. This value may differ from the real value.

For the target board clock, 0.16% or less is recommended as the serial communication error rate. Refer to the table of the bit-rate-register in the chapter of "Serial Communications" of Renesas Electronics hardware manual for the concerned MCU. If this error rate is more than above recommended 0.16%, the rate can't be raised at the target program transfer.

FLASH2 can control the target MCU into boot mode in programming procedure. For this automatic control function, the user's interface must be organized for the connections to MCU ports that specified in Renesas Electronics hardware manual for the concerned MCU. In the reference circuit diagrams in our "the User's Guide" we inform the connections including this function. Be careful about the interface signal names are named in convenient for the parameter setting. These terminal state select box can be used with the user's own idea, "MD0", "MD1", "I/O0", "I/O1", "I/O2" can be set at three levels of Low, High and High-Z, "FWE" can be set at two levels of Low and High; these terminal state can be set and remain in the memory corresponding to the MCU type. FLASH2 can progress the procedure, if these Mode control function does not work with their disconnections. Select "High-Z", when the mode control is arranged with the target board switches.

## ● Correspondence MCU

Please refer to "The list of supported flash memory MCU" (PDF) recorded on the provided CD for what MCU FLASH2 supports.

## ● Version upgrade

Version upgrade	Price	Notes <small>Prior to version upgrade, the product serial number is made sure.</small>
FLASH2 Version upgrade control soft ware	¥6000	Windows95, 98, Me, NT, 2000, XP, Vista, 7 and 8.1 Japanese version - Some types are not available - Consult us when you use our control ware in other environments.
FLASH2 1.02 firm ware upgrade*	¥7000	1.00 or 1.01 firm ware of FLASH2 can be upgraded to 1.02. Please send FLASH2 to our company.
FLASH2 Software and Programmer upgrade compatible to 1.02 firm ware*	¥10000	FLASH2 1.02 firm ware upgrade comes with the newest control CD for upgrading the soft ware version.

\*Upgrading compatible to 3v and R8C/M16C MCU series are included in this upgrade.

## Upgrading Control Software information

Only upgrading the control software, **FLASH2** can adapt to every new MCU of Flash memory MCU Microcomputers. For the series of single power supply, we present the new version for all Flash memory MCU Microcomputers releasing one after another. If you need your control software to upgrade, please refer our URL and send E-mail to our company. Our homepages helps you to confirm the adapted MCU types in the newest version.

URL : <http://www.hokutodenshi.co.jp>

E-mail : [support@hokutodenshi.co.jp](mailto:support@hokutodenshi.co.jp)

## ● Optional items

The followings are the optional items for FLASH2.

Name	Price	Notes
20-10pin FoUSB	¥2000	A conversion unit for R8C/M16C and a 10pins target cable.
20-14pin R8C	¥2000	A conversion unit for R8C and a 14pins target cable.
20-14pin M16C	¥2000	A conversion unit for R16C and a 14pins target cable.
20-14pin RX	¥2000	A conversion unit for RX and a 14pins target cable.
20-14pin 740	¥2000	A conversion unit for 740 and a 14pins target cable.
20-16pin V850	¥2000	A conversion unit for V850.

## ● Includes

These includes are purchasable.

Name	Price	Notes
AC 100 volt Adapter	¥2500	The provided AC adapter is verified for Japanese domestic use only.
FLASH2 Target Cable (20P)	¥1000	-
CD	¥6000	Please purchase version up software.

Please reconfirm about the charges for above.

## FLASH2 USER'S MANUAL – For Windows –

©2000-2014 北斗電子 Printed in Japan May 1st, 2000 1<sup>st</sup> ED REV.2.0.0.0(140411)

**HOKUTO DENSHI CO.,LTD** 株式会社 **北斗電子** 3-7, Odori-nishi 16, Chuoku Sapporo Hokkaido, 060-0042, Japan  
 phone+81-011-640-8800 fax+81-011-640-8801  
 e-mail : [support@hokutodenshi.co.jp](mailto:support@hokutodenshi.co.jp) (Technical support), [order@hokutodenshi.co.jp](mailto:order@hokutodenshi.co.jp) (Order and inquiries)  
 URL:<http://www.hokutoelectronic.com>