



# L-PRO

## Line Protection Relay

Model 2100, 2100E



## User Manual

Version 5.0 Rev 0



---

## Preface

Information in this document is subject to change without notice.

© 2015 ERLPhase Power Technologies Ltd. All rights reserved.

Reproduction in any manner whatsoever without the written permission of ERLPhase Power Technologies Ltd. is strictly forbidden.

This manual is part of a complete set of product documentation that includes detailed drawings and operation. Users should evaluate the information in the context of the complete set of product documentation and their particular applications. ERLPhase assumes no liability for any incidental, indirect or consequential damages arising from the use of this documentation.

While all information presented is believed to be reliable and in accordance with accepted engineering practices, ERLPhase makes no warranties as to the completeness of the information.

All trademarks used in association with B-PRO, Multi Busbar Protection, F-PRO, iTMU, L-PRO, ProLogic, S-PRO, T-PRO, TESLA, I/O Expansion Module, TESLA Control Panel, Relay Control Panel, RecordGraph and RecordBase are trademarks of ERLPhase Power Technologies Ltd.

Windows® is a registered trademark of the Microsoft Corporation.

HyperTerminal® is a registered trademark of Hilgraeve.

Modbus® is a registered trademark of Modicon.

## Contact Information

ERLPhase Power Technologies Ltd.

Website: [www.erlphase.com](http://www.erlphase.com)

Email: [info@erlphase.com](mailto:info@erlphase.com)

Technical Support

Email: [support@erlphase.com](mailto:support@erlphase.com)

Tel: 1-204-477-0591





---

## Using This Guide

This User Manual describes the installation and operation of the L-PRO line protection relay. It is intended to support the first time user and clarify the details of the equipment.

The manual uses a number of conventions to denote special information:

<b>example</b>	<b>Describes</b>
<i>Start&gt;Settings&gt;Control Panel</i>	Choose the Control Panel submenu in the Settings submenu on the Start menu.
Right-click	Click the right mouse button.
<i>Recordings</i>	Menu items and tabs are shown in italics.
<b>service</b>	User input or keystrokes are shown in bold.
Text boxes similar to this one	Relate important notes and information.
..	Indicates more screens.
	Indicates further drop-down menu, click to display list.
	Indicates a warning.



---

# Table of Contents

Preface .....	i
Contact Information .....	i
Using This Guide .....	iii
Table of Contents .....	v
Version Compatibility .....	vii
<b>1 Overview .....</b>	<b>1-1</b>
Front View .....	1-2
Rear View .....	1-3
Optional I/O Rear View .....	1-5
Model Options/Ordering.....	1-6
<b>2 Setup and Communications.....</b>	<b>2-1</b>
Power Supply .....	2-1
IRIG-B Time Input .....	2-1
Communicating with the Relay (IED) .....	2-2
Using HyperTerminal to Access the Relay's User Interface.....	2-5
Setting the Baud Rate.....	2-7
Accessing the Relay's SCADA Services.....	2-8
Communication Port Details .....	2-9
Maintenance Menu .....	2-12
Firmware Update .....	2-15
<b>3 Using the IED (Getting Started) .....</b>	<b>3-1</b>
Start-up Sequence .....	3-1
Front Panel Display.....	3-2
Terminal Mode .....	3-5
Metering Data .....	3-16
<b>4 Protection Functions and Specifications .....</b>	<b>4-1</b>
Protection and Recording Functions.....	4-1
Communication-Aided Scheme .....	4-40
Recording Functions .....	4-45
Logging Functions.....	4-47
<b>5 Offliner Settings Software .....</b>	<b>5-1</b>
Introduction .....	5-1
Installing PC Software.....	5-2
Offliner Features .....	5-2

---

Handling Backward Compatibility .....	5-4
RecordBase View Software .....	5-5
Main Branches from the Tree View.....	5-6
Settings From a Record .....	5-24
<b>6 Acceptance/Protection Function Test Guide .....</b>	<b>6-1</b>
Acceptance Testing .....	6-1
L-PRO Acceptance Test Procedure Outline .....	6-4
<b>7 Installation .....</b>	<b>7-1</b>
Physical Mounting.....	7-1
AC and DC Wiring.....	7-1
Communication Wiring.....	7-1
<b>8 Cyber Security .....</b>	<b>8-1</b>
System Access Control and Authorisation.....	8-1
Cyber Security Event Monitoring and Logging.....	8-3
Cyber Security Notification message format.....	8-4
IP Ports and Services .....	8-7
IEEE 1686 Table of Compliance.....	8-8
Appendix A IED Specifications.....	A-1
Distance Element Operating Time Curves at Nominal Frequency .....	A-4
Frequency Element Operating Time Curves.....	A-8
External Input Pickup Filter .....	A-9
Appendix B IED Settings and Ranges .....	B-1
Appendix C Hardware Description .....	C-1
Appendix D Event Messages .....	D-1
Appendix E Modbus RTU Communication Protocol ....	E-1
Appendix F DNP3 Device Profile .....	F-1
Appendix G Mechanical Drawings .....	G-1
Appendix H Rear Panel Drawings.....	H-1
Appendix I AC Schematic Drawings .....	I-1
Appendix J DC Schematic Drawings .....	J-1
Appendix K Function Logic Diagram.....	K-1
Appendix L L-PRO Setting Example .....	L-1
Switching Setting Groups.....	L-2
79 Auto-recloser examples .....	L-9
Index.....	I



# Version Compatibility

This chart indicates the versions of *Offliner* Settings, RecordBase View and the User Manual which are compatible with different versions of L-PRO firmware.

RecordBase View and *Offliner* Settings are backward compatible with all earlier versions of records and setting files. You can use RecordBase View to view records produced by any version of L-PRO firmware and *Offliner* Settings can create and edit older setting file versions.

Minor releases (designated with a letter suffix - e.g. v3.1a) maintain the same compatibility as their base version. For example, L-PRO firmware v3.1c and *Offliner* Settings v3.1a are compatible.

<b>L-PRO Firmware/Software Compatibility Guide</b>		
<b>L-PRO Firmware</b>	<b>Setting File Version</b>	<b>Compatible <i>Offliner</i> Settings</b>
v5.0	12	4000 v2.0 and greater
v4.0a	12	4000 v2.0 and greater
v4.0	12	4000 v2.0 and greater
v3.5a	12	v3.5 or greater
v3.5	12	v3.5 or greater
v3.4	11	v3.4 or greater
v3.3e	10	v3.3 or greater
v3.3d	10	v3.3 or greater
v3.3c	10	v3.3 or greater
v3.3b	10	v3.3 or greater
v3.3a	10	v3.3 or greater
v3.3	10	v3.3 or greater
v3.2c	9	v3.2 or greater
v3.2b	9	v3.2 or greater
v3.2a	9	v3.2 or greater
v3.2	9	v3.2 or greater
v3.1a	8	v3.1 or greater
v3.1	8	v3.1 or greater
v3.0b	7	v3.0 or greater
v3.0a	7	v3.0 or greater
v3.0	7	v3.0 or greater

Please contact ERLPhase Customer Service for complete Revision History.



# 1 Overview

## Introduction

The L-PRO (model 2100) is a microprocessor-based relay providing comprehensive distance based line protection, fault oscillography, dynamic swing recording and event logging with one integrated technology.

The primary protection is line protection with 4 zones of phase and ground distance functions – user-defined Mho or quadrilateral shapes and communication based schemes.

To provide a complete package of protection and control L-PRO provides other functions such as:

- 1.0 to 1.3 cycle operation at 80% reach, ideal for transmission line applications
- ring bus capability – breaker failure and individual breaker monitoring
- 4-shot recloser with dead line/dead bus control and sync check
- ProLogic addresses special protection needs
- 8 setting groups with setting group logic
- back up overcurrent protection
- over/under rate of change frequency devices
- Optional expanded I/O, up to 20 external inputs and 21 outputs

L-PRO has 2 working modes—online and offline. In the online mode you can use any communication software package (e.g. Procomm or HyperTerminal) to connect to the L-PRO using VT100 terminal emulation. In online mode you can:

- change and review relay settings
- view event and metering information
- initiate and retrieve recordings, and retrieve settings

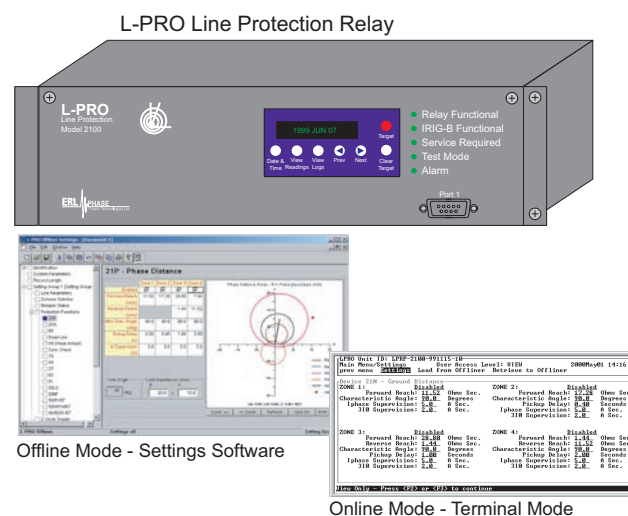

In offline mode you can use *Offliner Settings* and *RecordBase View* software to:

- create and review relay settings
- analyze fault waveforms
- store records

In addition to the protection functions L-PRO provides fault recording (96 samples/cycle) to facilitate analysis of the power system after a disturbance has taken place. The triggers for fault recording are established by programming the output matrix and allowing any internal relay function or any external input to initiate recording.

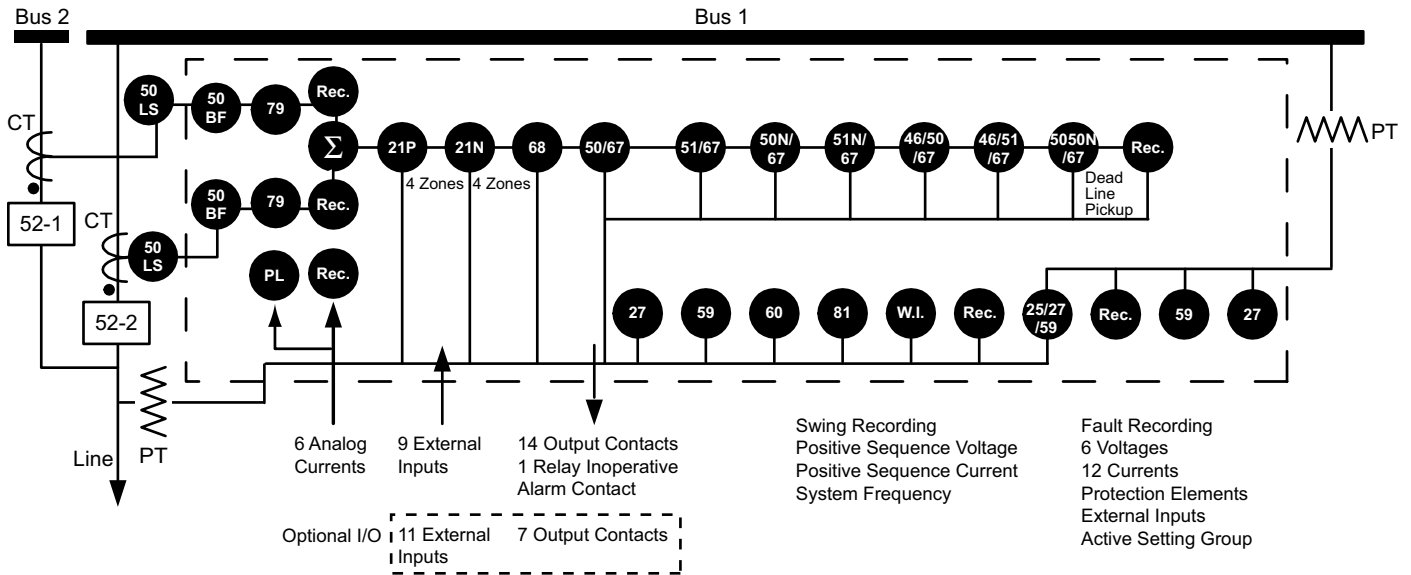

Figure 1.1: L-PRO Function Line Diagram

## Front View

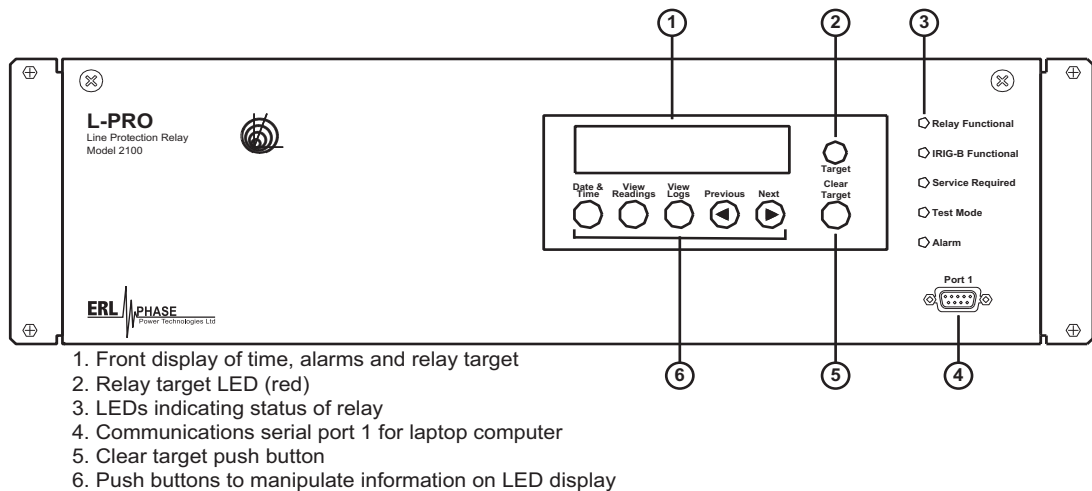
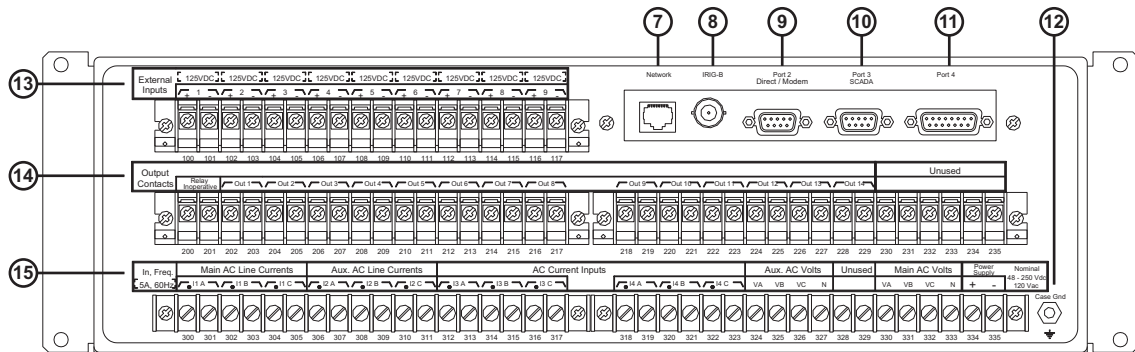

Figure 1.2: L-PRO Front View

## Rear View



7. Port 5 - 10BaseT Ethernet Port/Internal Modem (optional)
8. External clock, IRIG-B modulated or unmodulated
9. Port 2 - Direct/Modem RS-232 Port
10. Port 3 - SCADA
11. Port 4 - unused
12. Case ground
13. 9 programmable external inputs (1 to 9)
14. This row contains 2 distinct areas from left to right:
  - 14 programmable output relay contacts and relay inoperative contact
15. This row contains 3 distinctive areas from left to right:
  - Main and Auxiliary AC Line Currents (6 each) - for protection and recording
  - AC Current Inputs 2-3 phase current groups - for recording and 50LS function
  - Main and Auxiliary AC Voltage - for protection and recording
  - Power supply

Figure 1.3: L-PRO Rear View

**AC Current and Voltage Inputs**

L-PRO is provided with terminal blocks for up to 12 ac currents and 6 phase to neutral voltages.

Each of the current input circuits has polarity (•) marks.

A complete schematic of current and voltage circuits is shown, for details see “AC Schematic Drawings” in Appendix I and “DC Schematic Drawings” in Appendix J.

**External Inputs**

The L-PRO Relay contains 9 programmable external inputs. External dc voltage of either 48/125 volts or 125/250 volts nominal are possible depending on the range provided.

**Output Relay Contacts**

The L-PRO Relay has 14 output relay contacts. Each contact is programmable and has breaker tripping capability. All output contacts are isolated from each other. The dropout time for each output contact is configurable.

**Relay Inoperative Alarm Output**

If the relay becomes inoperative, then the Relay Inoperative Alarm output contact closes and all tripping functions are blocked.

## Optional I/O Rear View

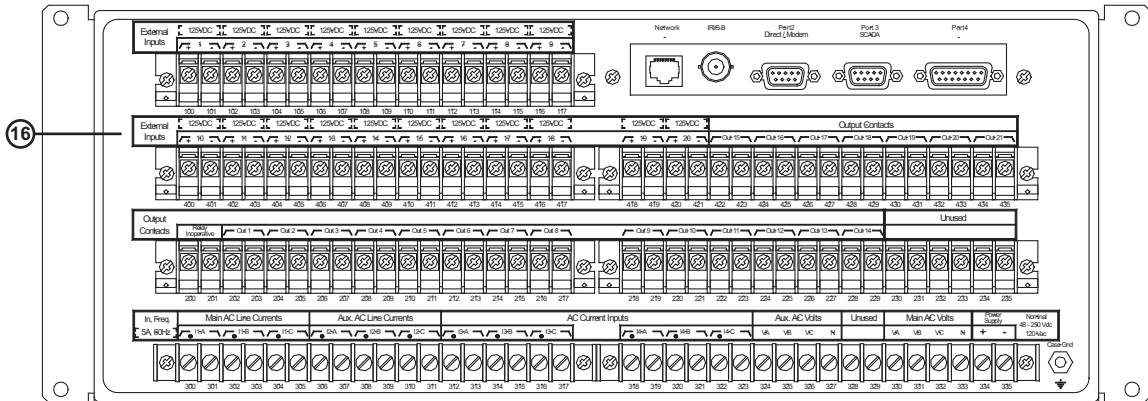

16. This row contains 2 distinctive areas from left to right:  
 11 programmable external inputs  
 7 programmable output relay contacts

Figure 1.4: Rear View of Optional I/O Model

### Optional External Inputs

The L-PRO Relay (model 2100E) contains 11 additional programmable external inputs. External dc voltage of either 48/125 volts or 125/250 volts are possible depending on the range provided.

### Optional Output Relay Contacts

The L-PRO Relay (model 2100E) contains 7 additional output relay contacts. Each contact is programmable and has breaker tripping capability. All output contacts are isolated from each other. The dropout time for each output contact is configurable.

## Model Options/Ordering

L-PRO is available for either horizontal or vertical mount, for details see “Mechanical Drawings” in Appendix G.

L-PRO is available with an internal modem card or internal modem network card.

The CT inputs are 1 A nominal or 5 A nominal. The external inputs are 48/125 Vdc or 125/250 Vdc. The system base frequency is either 50 Hz or 60 Hz.

The L-PRO is available with an optional I/O board as described above.

All of the above options must be specified at the time of ordering.

### Relay Method of Memory Polarization

The 21P and 21N mho elements use positive-sequence voltage, derived from a memory voltage, as the polarizing quantity. Sufficient positive-sequence voltage should be available during all fault events. However, during certain fault events, especially three-phase bolted faults near the line VT location, the positive-sequence voltage may be insufficient for correct operation. To ensure adequate positive-sequence voltage exists for all fault conditions, the L-PRO uses a ring filter, implemented in software, to provide memory voltage as the source for the positive-sequence voltage. This memory voltage lasts for approximately 150 cycles, even if all voltage inputs from the line VTs go to zero. A practical effect of using a memorized voltage is to expand the mho characteristic by the source impedance. This expansion of the characteristic ensures correct operation for zero voltage faults at the relay location, and for forward capacitive faults.

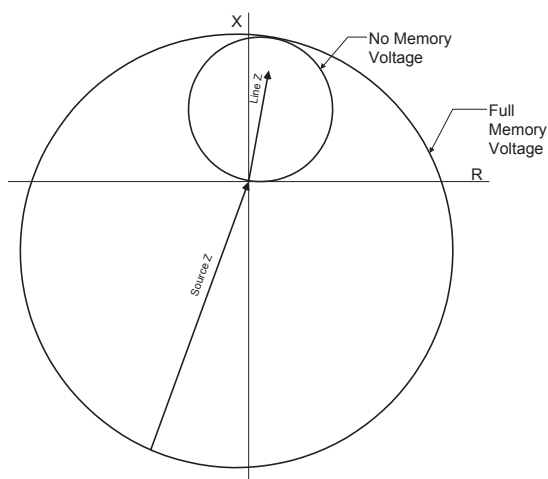



---

## 2 Setup and Communications

### Power Supply

A wide range power supply is standard. The nominal operating range is 48 to 250 Vdc, 120 Vac, 50/60 Hz. To protect against a possible short circuit in the supply use an inline fuse or circuit breaker with a 5 A rating. Make the chassis ground connection to ensure proper operation and safety.

There are no power switches on the relay. When the power supply is connected, the relay starts its initialization process and takes about 40 seconds to complete showing the green Relay Functional LED.

### Case Grounding

You must ground the relay to the station ground using the case-grounding terminal at the back of the relay, for details see Figure 1.3: L-PRO Rear View on page 1-3.

**WARNING!**

To ensure safety and proper operation you must connect the relay to the station ground using the rear grounding terminal on the relay.

Ground the relay even when testing.

Do not rely on the rack mounting screws to provide case grounding.

### IRIG-B Time Input

The relay is equipped to handle modulated or unmodulated GPS satellite time IRIG-B signals. The IRIG-B time signal is connected to the BNC connection on the back of the relay. When the IRIG-B signal is provided to the relay the IRIG-B functional LED comes on and the relay clock is referenced to this signal. No settings are required to differentiate between modulated or unmodulated signals; this is automatically detected by the relay.

You can enable or disable the IEEE 1344 extension in the terminal mode settings *Utilities>Setup>Time*, for details see “Utilities” on page 3-14. The enabled mode allows the year to be received from the IRIG-B signal. If the available IRIG-B signal has no year extension, this setting should be disabled.

## Communicating with the Relay (IED)

There are different ways you can connect to the relay to access its user interface and SCADA services:

- Direct serial link: (user interface and SCADA)
- Modem link - external or internal: (user interface only)
- Ethernet network link: (user interface and SCADA)

### Direct Serial Link

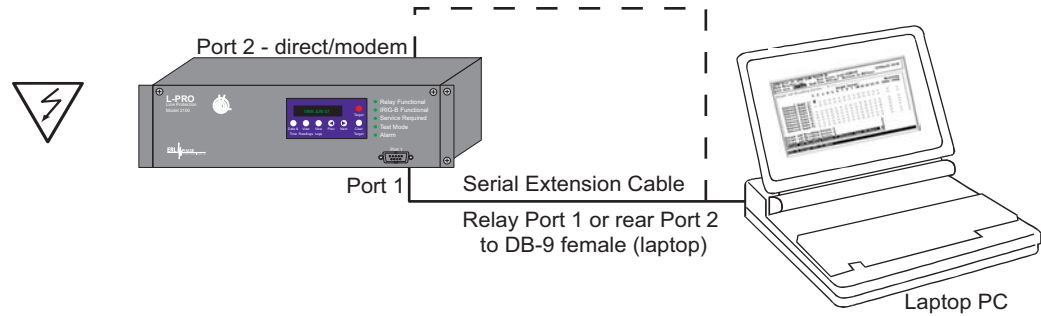

Figure 2.1: Direct Serial Link

The relay has 3 serial ports that provide direct access to its user interface and SCADA services.

All of the relay's serial ports (Ports 1, 2 and 3) are configured as EIA RS-232 Data Communications Equipment (DCE) devices with female DB9 connectors. This allows them to be connected directly to a PC serial port with a standard straight-through male-to-female serial cable, for pin-out, for details see "Communication Port Details" on page 2-9.

The relay's user interface is accessed through a standard VT-100 terminal emulation program running on a PC. To create a direct serial link between the relay and your computer, connect the serial cable (provided) between your computer's serial port and Port 1 on the relay's front panel. Port 2 on the relay's rear panel can also be used for direct serial access, provided the port is not configured for modem use. When connected, run the terminal emulation software on your computer to establish the communication link, for details see "Using HyperTerminal to Access the Relay's User Interface" on page 2-5.

The relay's Modbus and DNP3 SCADA services can be accessed via a direct serial link to Port 3 on the relay's rear panel, for details see "Accessing the Relay's SCADA Services" on page 2-8.

## Modem Link - External

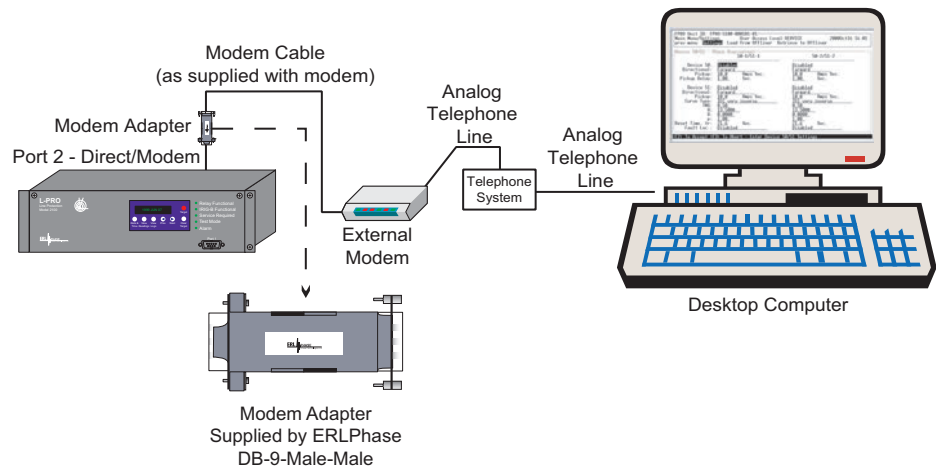

Figure 2.2: External Modem Link

Using an external modem, you can also access the relay's user interface through a telephone link between the relay and your computer.

Connect the serial port on the external modem to the Port 2 on the relay's rear panel. Both devices are configured as RS-232 DCE devices with female connectors, so the cable between the relay and the modem requires a crossover and a gender change. Alternatively, you can use the ERLPhase modem port adapter provided with the relay to make Port 2 appear the same as a PC's serial port. A standard modem-to-PC serial cable can then be used to connect the modem and the relay. For pin-out details see "Communication Port Details" on page 2-9.

Connect the modem to an analog telephone line or switch using a standard RJ-11 connector.

You must appropriately configure the relay's Port 2 to work with a modem. Log into the relay through a direct serial link, go to the *Utilities>Setup>Ports* screen, and set *Port 2 Modem* option to *Yes*. Set the *Baud Rate* as high as possible — most modems handle 57,600 bps. The *Initialize* setting allows you to set the control codes sent to the modem at the start of each connection session. The factory defaults are: "M0S0=0&B1" for an external modem and "M0S0=0" for an internal modem.

## Modem Link - Internal

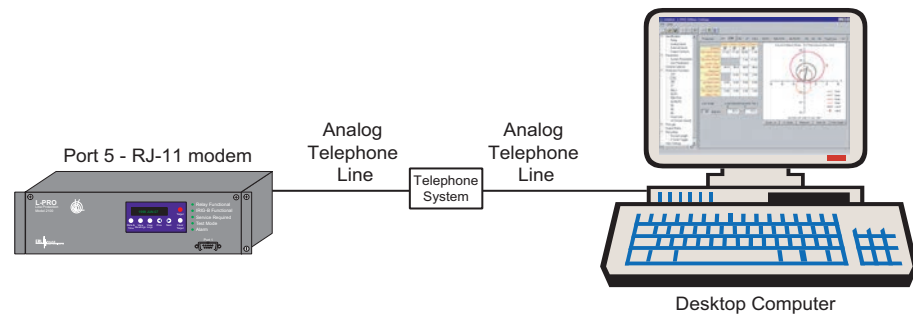

Figure 2.3: Internal Modem Link

You can access the relay's user interface through a telephone link between the relay and your computer using an optional internal modem. If the modem has been installed, Port 5 on the rear panel is labelled "INTERNAL MODEM."

Connect the relay's Port 5 to an analog telephone line or switch using a standard RJ-11 connector.

When an internal modem is installed, the relay's Port 2 is used to interface to the modem internally. Appropriate Port 2 settings are configured at the factory when the internal modem is installed. The factory defaults are: "M0S0=0&B1" for an external modem and "M0S0=0" for an internal modem.

## Network Link

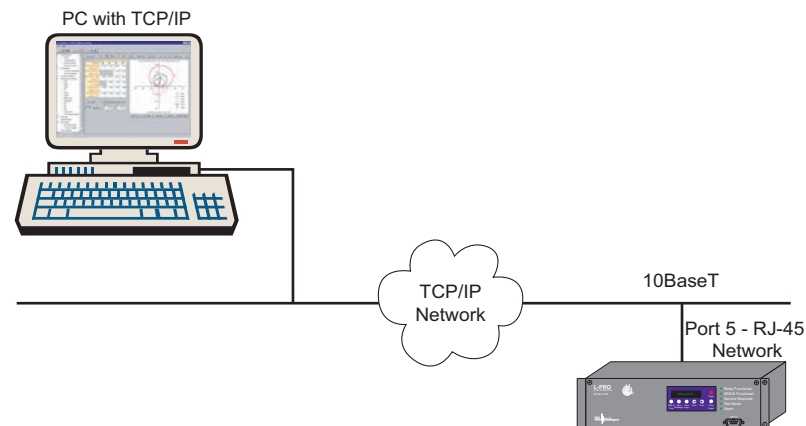

Figure 2.4: Network Link

An optional Ethernet TCP/IP LAN link lets you access both the relay's user interface and DNP3 SCADA services simultaneously through the same network port. If the Ethernet option has been installed, Port 5 on the rear panel will be labelled "NETWORK."

The user interface accessed through the LAN is the same as that available through a direct serial connection or a modem link, but requires the use of a Telnet client on your PC. The HyperTerminal program, which is included in Windows XP and is also available separately as HyperTerminal PE, provides Telnet services. To select Telnet, go to HyperTerminal's Properties dialogue and set the *Connect Using* field to TCP/IP (Winsock). If this option is not available in the pick list, you will require a newer version of HyperTerminal (v1.2

or greater). Alternatively, you can use any Telnet program that fully supports VT-100 terminal emulation and z-modem file transfer.

DNP3 SCADA services can also be accessed over the LAN, for details see “Accessing the Relay’s SCADA Services” on page 2-8.

Connect Port 5 to the Ethernet LAN using an appropriate 10BaseT cable with an RJ-45 connector. The relay supports 10 Mbit Ethernet, although a dual speed 10/100 Ethernet hub or switch can be used.

By default, the relay is assigned an IP address of 192.168.1.100. If this address is not suitable, it may be modified using the relay’s Maintenance Menu, for details see “Maintenance Menu” on page 2-12.

## Using HyperTerminal to Access the Relay’s User Interface

The relay’s user interface lets you change settings, view measured values and retrieve data from the relay. This section describes how to configure a standard Windows VT-100 terminal program on your PC for use with the relay.

The computer must be connected to the relay via one of its serial, modem or Ethernet communication ports. See the preceding Communicating with the Relay section for details on making these connections.

The relay user interface is accessed using a standard VT-100 terminal style program on your computer, eliminating the need for specialized user interface software. Any terminal program that fully supports VT-100 emulation and provides z-modem file transfer services can be used. The HyperTerminal program, which is included in some versions of Microsoft Windows and is also available separately as HyperTerminal PE, is used here as an example.

Configure your terminal program as described in the table below and link it to the appropriate serial port, modem or TCP/IP socket on your computer.

Terminal Program Setup	
Baud rate	For a direct serial link, the baud rate must match that of the relay serial port. For a modem link, the baud rate refers only to the link between your computer and its own modem. Refer to “Setting the Baud Rate” on page 2-7 for further information
Data bits	8
Parity	None
Stop bits	1
Flow control	Hardware or Software. Hardware flow control is recommended. The relay automatically supports both on all its serial ports.
Function, arrow and control keys	Terminal keys
Emulation	VT100

**Terminal Program Setup**

Font	Use a font that supports line drawing (e.g. Terminal or MS Line Draw). If the menu appears outlined in odd characters, the font you have selected is not supporting line drawing characters.
------	--

To initiate the connection with the relay, use HyperTerminal's *Call>Connect* function.

When the connection is established, press ENTER in the terminal window to bring up the following login prompt:

```

----- ERLPhase L-PRO 2100 Terminal User Interface login -----

Log in using one of the following usernames:
'view' - read-only access to settings and readings
'change' - read/write access to settings and readings
'service' - full access to all functions (Port 1 access only)
'maintenance' - access to the maintenance menu
'update' - to load a firmware update (Port 1 access only)

Notes:
- Serial and modem connections have a 60 minute inactivity timeout
- Usernames and passwords are case sensitive

login:

```

Instructions on logging in and running the user interface are given in “Terminal Mode” on page 3-5.

If you see incorrect characters on a direct serial connection, it may mean there is a mismatch between the relay's baud rate and that of the PC.

**Ending a User Interface Session**

Use the Quit function in the relay's user menu to end a session. This will close the interface and require the next user to log in to the relay.

The relay automatically ends a session when it detects the disconnecting of a direct serial cable or a modem hang-up. For other types of connections (e.g. serial switches or Ethernet) you are advised to use the Quit function to ensure the interface is closed and login protection is activated.

---

## Setting the Baud Rate

The baud rate of the relay's serial ports can be shown on the relay's front panel display. From the main *Date & Time* display, press the *Next* button.

### Direct Serial Link

For a direct serial connection, both the relay and your computer must be set to the same baud rate.

To change the baud rate of a relay serial port:

- 1 Access the relay's user interface through any of the available ports
- 2 Log in to the user interface and go to the *Utilities>Setup>Ports* menu, for details see “Terminal Mode” on page 3-5.
- 3 Select the desired baud rate for the appropriate port by toggling through the options using the Space or Enter keys. Save the new setting with the F2 key. The message “New communications settings loaded” will appear.

The new baud rate will be used on that port the next time you log in to it.

To change the baud rate on your computer's serial port:

- 4 From within HyperTerminal, bring up the Properties dialogue, press the *Configure* button and set the baud rate field to the desired value.
- 5 Save the changes.

### Modem Link

Unlike a direct serial link, the baud rates for a modem link do not have to be the same on your computer and on the relay. The modems automatically negotiate an optimal baud rate for their communication.

The baud rate set on the relay only affects the rate at which the relay communicates with the modem. Similarly, the baud rate set in HyperTerminal only affects the rate at which your computer communicates with its modem. Details on how to set these respective baud rates are described above, except that you modify the Port 2 baud rate on the relay and the properties of the modem in HyperTerminal.

---

## Accessing the Relay's SCADA Services

The relay supports DNP3 (Level 2) and Modbus SCADA protocols as a standard feature on all ERLPhase relays. DNP3 is available through a direct serial link or the Ethernet LAN on top of either TCP or UDP protocols. The Modbus implementation supports both RTU (binary) or ASCII modes and is available through a direct serial link.

The relay's Port 3 is dedicated for use with Modbus or DNP3 serial protocols. Port 3 uses standard RS-232 signalling. An external RS-232<->RS-485 converter can also be used to connect to an RS-485 network.

For details on connecting to serial Port 3 see "Communicating with the Relay (IED)" on page 2-2 and "Communication Port Details" on page 2-9.

The DNP3 protocol can also be run across the optional Ethernet LAN. Both DNP over TCP and DNP over UDP are supported. For details on connecting to the Ethernet LAN see "Network Link" on page 2-4.

Complete details on the Modbus and DNP3 protocol services can be found in the Appendices, for details see "Modbus RTU Communication Protocol" in Appendix E and "DNP3 Device Profile" in Appendix F.

### Protocol Selection

To select the desired SCADA protocol, open the setting file. Set the protocol and set the corresponding parameters.

The DNP3 LAN/WAN - TCP and UDP options are only available if the unit has an optional Ethernet LAN port installed.

### Communication Parameters

Port 3's communication parameters are set using the *Utilities>Setup>Ports* menu in relay's user interface. Both the baud rate and the parity bit can be configured. The number of data bits and stop bits are determined automatically by the selected SCADA protocol. Modbus ASCII uses 7 data bits. Modbus RTU and DNP Serial use 8 data bits. All protocols use 1 stop bit except in the case where either Modbus protocol is used with no parity; this uses 2 stop bits, as defined in the Modbus standard.

### Diagnostics

Protocol monitor utilities are available to assist in resolving SCADA communication difficulties such as incompatible baud rate or addressing. The utilities can be access through the Maintenance user interface, for details see "Maintenance Menu" on page 2-12.



## Communication Port Details

Port	Location	Function
1	Front Panel	RS-232 Data Communication Equipment (DCE) female DB9. Used for user interface access via a direct serial connection. Default Setting: 38,400 baud, 8 data bits, no parity, 1 stop bit.
2	Rear Panel	RS-232 DCE female DB9. Used for: <ul style="list-style-type: none"> <li>• User interface access via a direct serial connection.</li> <li>• User interface access via an external modem. The optional ERLPhase Modem Adapter converts this port to a Data Terminal Equipment (DTE) to simplify connection to an external modem.</li> </ul> Default Setting: 9,600 baud, 8 data bits, no parity, 1 stop bit. Port 2 is disabled if the relay is equipped with an internal modem (see Port 5).
3	Rear Panel	RS-232 DCE female DB9. Used for SCADA communication. Default Setting: 9,600 baud, 8 data bits, no parity, 1 stop bit.
4	Rear Panel	Not used
5	Rear Panel	RJ-11/RJ-45 receptacle. When equipped with optional internal modem: <ul style="list-style-type: none"> <li>• Used for user interface access via modem.</li> </ul> When equipped with optional internal Ethernet card: <ul style="list-style-type: none"> <li>• User interface access.</li> <li>• DNP SCADA access.</li> </ul> Default Ethernet IP address: 192.168.1.100.

Signal Name	Direction PC<-> Relay	Pin # on the Relay Port
DCD	←	1
RxD	←	2
TxD	→	3
DTR	→	4
Common		5
DSR	←	6
RTS	→	7
CTS	←	8
No connection		9

## Notes:

- Relay is DCE, PC is DTE
- Pins 1 and 6 are tied together internal to the relay

Male DB-9 Cable End for Relay Port	Female DB-9 Cable End for Computer Port
Pin # on Cable	Pin # on Cable
1	1
2	2
3	3
4	4
5	5
6	6
7	7
8	8
9	9

---

Signal Name	Direction Modem <-> Relay	Pin # on the Modem Adapter
DCD	→	1
RxD	→	2
TxD	←	3
DTR	←	4
Common		5
DSR	→	6
RTS	←	7
CTS	→	8
No connection		9

## Notes:

- Relay (with modem adapter) is DTE, modem is DCE
- Pins 1 and 6 are tied together internal to the relay

## Maintenance Menu

The relay has a Maintenance Menu that can be accessed by connection through a VT-100 terminal emulator (such as the HyperTerminal program). Using either direct serial or modem connection:

- 1 Use the terminal program to connect to the serial port, either through direct serial link or modem.
- 2 Select *Enter*, the relay responds with a login prompt.

```

----- ERLPhase L-PRO 2100 Terminal User Interface login -----
Log in using one of the following usernames:
'view' - read-only access to settings and readings
'change' - read/write access to settings and readings
'service' - full access to all functions (Port 1 access only)
'secadmin' - access to security configuration
'maintenance' - access to the maintenance menu
'update' - to load a firmware update (Port 1 access only)

Notes:
- Serial and modem connections have a 60 minute inactivity timeout
- Usernames and passwords are case sensitive

login:

```

Figure 2.5: Login Prompt

- 3 Login as “maintenance” in lower case.
- 4 Relay responds with “password” prompt.

```

login: maintenance
Last login: Mon Nov 16 22:47:57 2015 on //1/dev/ser1
Mon Nov 16 22:53:23 2015
password:

```

Figure 2.6: Maintenance Password Prompt

- 5 Enter password.
- 6 A menu appears as below:

```

L-PRO 2100 System Utility v1.4
ERLPhase Power Technologies Ltd.
Customer support : (204) 477-0591, support@erlphase.com

1 : *Modify IP Address, subnet mask and default gateway (if applicable)
2 : View system diagnostics
3 : Retrieve system diagnostics
4 : *Restore ALL default settings, including calibration
5 : *Restore only default configuration settings
      (channel definitions, device settings)
6 : *Restore only default system setup (ports, time settings)
7 : *Force hardware reset
8 : Network utilities (if applicable)
9 : Monitor SCADA
10: *Enable/Disable Internal Modem (if one exists)
11: Exit

      * port 1 access only

Please enter a command:
[1-11] #

```

Figure 2.7: Maintenance Menu

## Maintenance Menu Commands

Please enter a command:1-11	
1	Modify IP Address, subnet mask and default gateway (if applicable).
2	View system diagnostics.
3	Retrieve system diagnostics.
4	Restore all default settings, including calibration.
5	Restore only default configuration settings (channel definitions, device settings).
6	Restore only default system setup (ports, time settings).
7	Force hardware reset.
8	Network utilities (if applicable).
9	Monitor SCADA.
10	Enable/disable internal modem (if one exists)
11	Exit.

Commands 1, 4, 5, 6, 7 and 10 are Port 1 access only.

Modify IP address	Modifies the LAN IP address when equipped with an optional internal 10BaseT Ethernet card.
View system diagnostic	Displays the internal status log.
Retrieve system diagnostics	Automatically packages up the internal status log plus setting and setup information and downloads it in compressed form to your computer. This file can then be sent to our customer support to help diagnose a problem.
Restore settings	Use this menu to force the system back to default values, if you suspect a problem due to the unit's settings, calibration and/or setup parameters.
Force hardware reset	Manually initiates a hardware reset. Note that the communication link is immediately lost and cannot be re-established until the unit completes its start-up.
Network utilities	Enters network utilities sub-menu.
Monitor SCADA	Shows real time display of SCADA data.
Enable/disable Modem	Enables or disables the internal modem.

**Network Utilities  
Menu Commands \***

Please enter a command:1-5	
1	View protocol statistics
2	View active socket states
3	View routing tables
4	Ping
5	Exit network utilities

View protocol statistics	View IP, TCP and UDP statistics
View active socket states	View current states of active sockets
View routing tables	View routing tables
Ping	Check network connection to given point
Exit network utilities	Exit network utilities menu and return to Maintenance Menu Commands

\* Accessible when equipped with internal Ethernet card

---

## Firmware Update

The relay has an update login that can be accessed by a connection through a VT100 terminal emulator (such as HyperTerminal). This login is available only from Port 1.

- 1 Use the terminal program to connect to Port 1.
- 2 Select *Enter*, the terminal responds with a login prompt (Figure 2.8: Firmware Update Password Prompt ).
- 3 Login as “update” in lower case.
- 4 Relay responds with “password” prompt.

```
login: update
Last login Mon Nov 16 19:36:28 2015 on //1/dev/ser1
Mon Nov 16 23:23:11 2015
Password:-
```

Figure 2.8: Firmware Update Password Prompt

- 5 Enter password.

The firmware update is used to update the relay’s software with maintenance or enhancement releases. Please see the L-PRO Firmware Update Procedure documentation that comes with the firmware update for instructions on how to update the firmware.







## Front Panel Display

View or change settings using Terminal Mode or loading a setting file from *Offliner* Setting.

The front panel display is the fastest and easiest way of getting information from the relay.

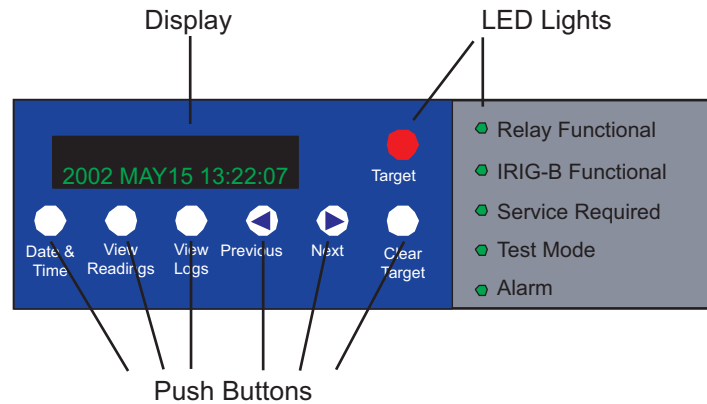

Figure 3.1: Front Panel Display

The display, the 6 LED lights and the 6 push buttons provide selective information about the relay.

### LED Lights

Relay Functional	Indicates when the relay is functional. When the Relay Functional green LED goes on, the rear Relay Inoperative contact changes to open and the protective functions become functional.
IRIG-B Functional	Indicates the presence of a valid IRIG-B time signal.
Service Required	Indicates the relay needs service. This LED can be the same state as the Relay Functional LED or can be of the opposite state depending on the nature of the problem. The following items bring up this LED: <ul style="list-style-type: none"> <li>• DSP failure - protection difficulties within the relay.</li> <li>• Communication failure within the relay.</li> <li>• Internal relay problems.</li> </ul>
Test Mode	Occurs when the relay output contacts are intentionally blocked. Possible reasons are: <ul style="list-style-type: none"> <li>• Relay initialization on start-up</li> <li>• User interface processor has reset and is being tested.</li> </ul> You cannot communicate with the relay through the ports until the front display becomes active and the Test Mode LED goes out. Normally, the red Target LED remains off after this start-up unless the relay had unviewed target messages. Output contacts are controlled from the <i>Utilities</i> menu.

Alarm	Occurs when an enabled relay function picks up. The red Alarm LED should be off if there are no inputs to the relay. If the Alarm LED is on, check the event log messages on the front display by pressing the <i>View Logs</i> button.
Target	Indicates that a fault has taken place. An event message with date and time is presented in the display.

## Push Buttons

Date&Time	Pressing the Date&Time button displays the date and time stored on the relay. If the time is incorrect, use the <i>Utilities&gt;Setup&gt;Time</i> function in the Terminal Mode user interface to set it manually, or connect an IRIG-B signal source to the IRIG-B port at the back of the relay to set it automatically. The year may need to be set manually if it is not provided as part of the IRIG-B signal
View Readings	Pressing the View Readings button obtains metering information about the transmission line, for details see "Display" on page 3-4.
View Logs	Pressing the View Logs button displays the target information if a relay operation has occurred, for details see "Display" on page 3-4.
Previous/Next	Scroll through the menu by pressing Previous and Next. When the Date & Time is displayed, pressing either of these buttons will display the current Port 1 and Port 2 baud rates.
Clear Target	When a fault takes place, the red target light appears. You can select a setting option to reset the target light after a short time delay. Use the Clear Target button to view all target information. If many faults have been stored, you may need to push this button several times. Clearing the target light does not clear the target information from the relay log. The relay holds all target messages during a power supply shutdown and restart. Pressing the Clear Target push button displays any targets not previously viewed on the front display and clears the Target LED after the last target has been viewed.

## Display

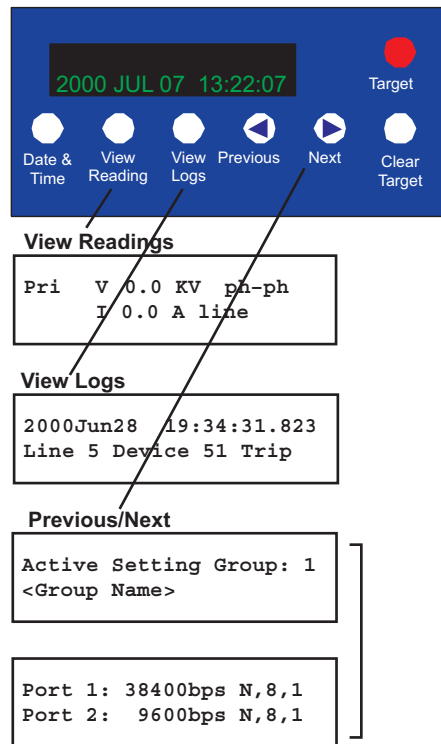

Figure 3.2: Display examples

Pressing *Previous* and *Next* navigates through the Active Setting Group.

L-PRO Front Panel Display Messages
PRI V, I, P, Q
Va, Ia magnitude and angle
Vb, Ib magnitude and angle
Vc, Ic magnitude and angle
Frequency
Fault location, trip date and time and all functions.

## Terminal Mode

- 1 Establish terminal mode connection, for details “Using HyperTerminal to Access the Relay’s User Interface” on page 2-5.
- 2 Login as one of **view**, **change**, **service** or **secadmin** (lower case). These 4 login names provide differing levels of permission.
- 3 When connection is established and the terminal mode program appears on your screen, the following prompt should appear. If it doesn’t appear, press *Enter*.

```

----- ERLPhase L-PRO 2100 Terminal User Interface login -----
Log in using one of the following usernames:
'view' - read-only access to settings and readings
'change' - read/write access to settings and readings
'service' - full access to all functions (Port 1 access only)
'secadmin' - access to security configuration
'maintenance' - access to the maintenance menu
'update' - to load a firmware update (Port 1 access only)

Notes:
- Serial and modem connections have a 60 minute inactivity timeout
- Usernames and passwords are case sensitive

login:

```

- 4 If login is successful, the Main Menu appear as follows:
  - for **view**, **change** or **service** login

```

LPRO Unit ID: UnitID
Main Menu          User Access Level: VIEW          2015Nov17 22:28
ID Settings Metering Records Event Log Utilities Access Quit

```

view, change or service  
(depends on how you log in)

- for **secadmin** login

```

LPRO Unit ID: UnitID
Main Menu          User Access Level: SECADMIN      2015Nov17 23:24
ID Passwords Syslog Quit

```

5 If login is unsuccessful, the Status Message appear as follows:

```
Status Message
Incorrect Password
<any key>
```

Unit allows 7 unsuccessful login attempts before locking out the Access Level for 5 minutes. Any attempts to login into locked out Access Level will fail. Access lockout and lockout period are Access Level specific, i.e. if an Access Level is locked out, the other Access Levels remain unaffected.

If the box around the menu does not appear as above, change the font in your terminal program to one that supports line draw characters, e.g. terminal fonts.

If there are incorrect characters in the display, improper line feeds or unerased portions, the baud rate is too high for the quality of the communication link. Use the *Utilities>Setup>Ports* menu to reduce the relay's baud rate. The new rate is in effect at the next connection.

The relay supports 4 user access levels that control what relay functions are available to user. The current access level is always shown in the centre of the Main Menu heading.

To change the Access Level either login again using the desired access level as your login name. To change between **view**, **change** and **service** Access Level you can also use the *Main Menu>Access* menu.

Access Level	Login Name	Level/Function	Authorized Functions
view	view	lowest	View settings, online readings and logs. List and retrieve records. At this level you cannot affect the operation of the controller.
change	change	middle	Do all of the above, plus change the settings and delete records.
service	service	highest	Do all of the above 2 categories, plus calibrate the analog inputs, manually control output auxiliary relays and modify passwords.
secadmin	secadmin	security	Change passwords. View/change Syslog configuration.

maintenance	maintenance	mainte- nance	Configure IP address, subnet mask, default gateway IP address. Restore default configuration/settings/calibration. Enable/disable modem. View/retrieve system diagnostics.
update	update	update	Firmware update

Service access is only available through the local, front port connection (Port 1).

You can configure change access so that it is only allowed from Port 1.

## Login Passwords

Individual passwords for all Access Levels are available to prevent or limit access to the IED. Passwords are mandatory. Units arrive from the factory with default passwords installed. Default passwords are as follows.

Access Level/Login Name	Default Password
view	view
change	change
service	service
secadmin	secadmin
maintenance	maintenance
update	update

The following rules are applied, when firmware is upgraded to a version with **secadmin** login for the first time

- the current password is preserved, if Access Level has a password assigned to it;
- a default password is assigned to an Access Level, if Access Level does not have a password assigned to/associated with it.

## Terminal Mode Menus

Use the right and left arrow keys and the Enter key to move around in the terminal mode screen. The mouse does not work in VT100 terminal mode. Items from the menu are selected by moving the highlight to the desired item and ac-

tivating it using the Enter key. As a short-cut, use the first letter of the menu item to access it directly.

Key	Function
<F2>	Accept or Freeze or Execute
<F3>	Quit or Exit
<F4>	Copy Group
<Esc>	Back to previous menu level

The menu tree consists of a series of sub-menus, for details see Figure 3.3: Terminal Mode Menus for view, change and service login on page 3-9.

The Enter key allows you to toggle through a list of selections, i.e. enabled/disabled. The Enter key toggles forward through the list, while the space bar moves backward through the list. In this manner you do not have to scroll through the entire list to get back to a previous selection, you can use the space bar.

For certain lists a pick box appears when there is a long list of selections to chose from, for example, ProLogic inputs. You can scroll though these boxes with the arrow keys or the Enter key. Use the F2 key to make a selection or F3 to leave.



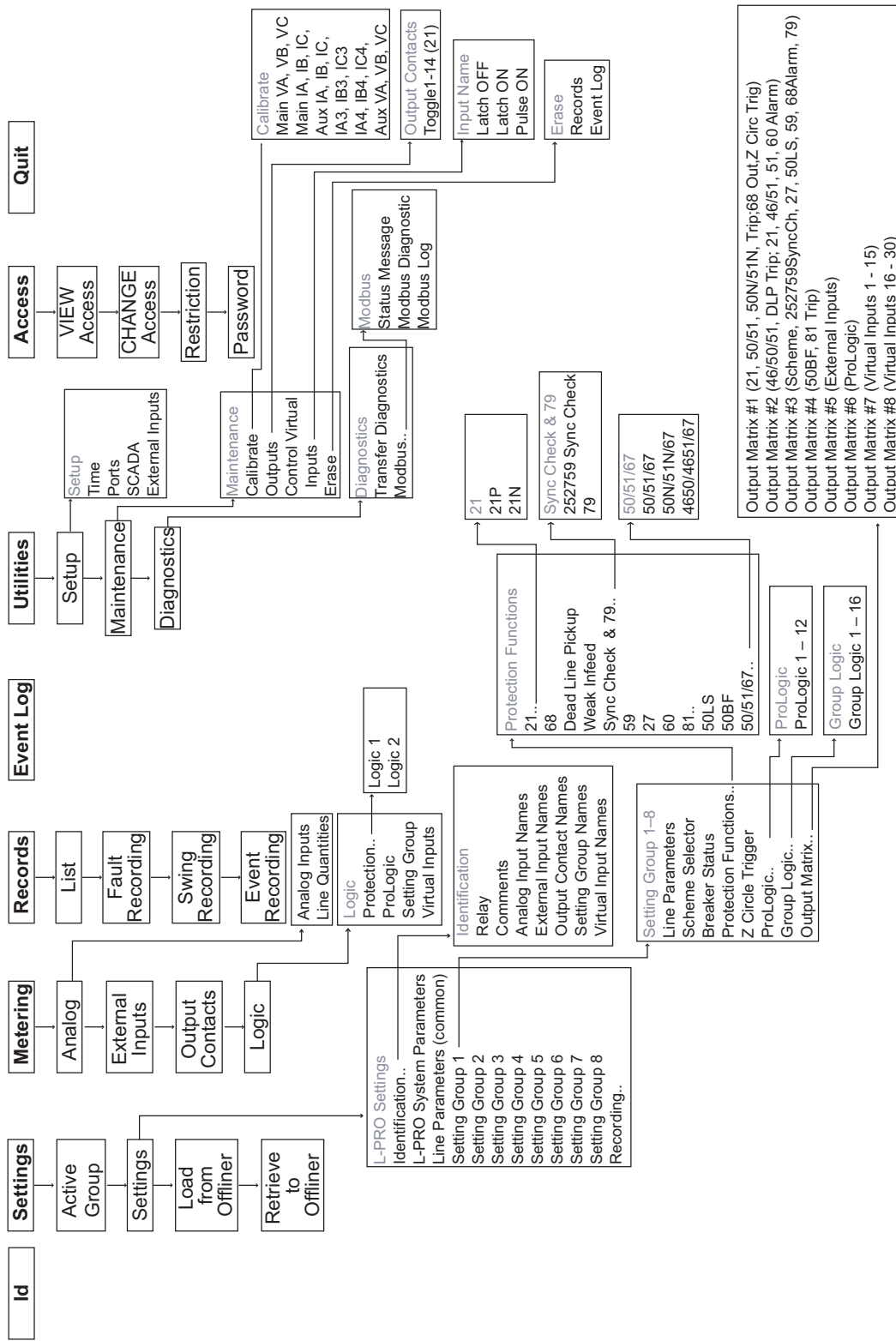

Figure 3.3: Terminal Mode Menus for view, change and service login

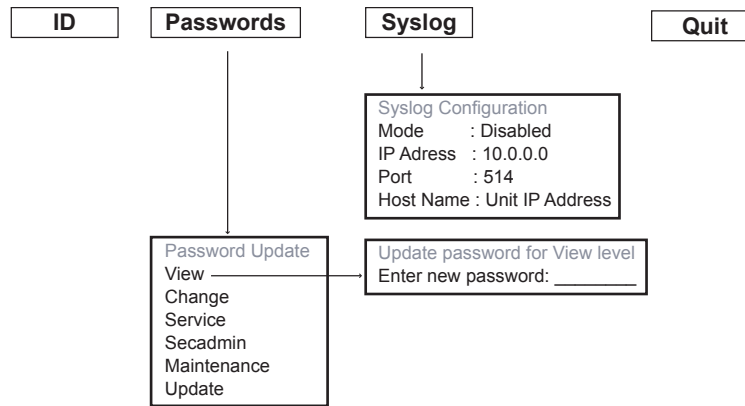

Figure 3.4: Terminal Mode Menus for **secadmin** Login

The Main Menu display is

```

ID Settings Metering Records Event Log Utilities Access Quit
  
```

**ID**

Provides the device serial number, hardware revision, software version, required settings version, nominal system values and external input board rating. There are no user settings here.

## Settings

Submenus: Active Group, Settings, Load from *Offliner*, Retrieve to *Offliner*  
 Allows input of all the setting information for the relay. Includes all the submenus to change relay settings related to protection functions, when settings are changed they are not saved until you confirm the changes—Save and Load Setting Changes Now? [y/n].

### Settings

Settings includes all the submenus pertaining to protection functions used to create a relay setting. When these settings are made or changed, you can load them into the relay allowing input of all settings information for the relay.

Settings submenus: Identification, L-PRO System Parameters, Line Parameters (common), Setting Group 1 to 8, Recording.

Identification..	
Relay	Serial Number, Software Version, Relay ID, Line Name, Station Name, Station Number and Location.
Comments	Enter any appropriate comment.
Analog Input Names	Name inputs, Main VA, VB, VC, Main IA, IB, IC, Aux IA, IB, IC, IA3, IB3, IC3, IA4, IB4, IC4, Aux VA
External Inputs Names	Name external inputs 1 to 9.
Output Contact Names	Name auxiliary relay output contacts 1 to 14.
Setting Group Names	Name setting groups 1 to 8
Virtual Input Names	Name virtual inputs 1 to 30

The following characters are not allowed in the above setting parameters: “ ”, “\”, “/”, “.”, “\*”, “?”, “|”, “|”, “|”, “<”, and “>”.

### Load From *Offliner*

You can download the settings file into the relay using the terminal mode menu.

- 1 On the Window’s desktop, double-click L-PRO *Offliner* Settings icon. The initial *Offliner* Settings screen appears.
- 2 Enter the required settings.
- 3 Save the settings to a file on your PC.
- 4 Start the Terminal Mode of L-PRO, login as **change** or **service**, then access the *Settings* menu and activate *Load from Offliner* function.
- 5 Reply *Yes* to the “Ready to load remote setting.” prompt.
- 6 In your terminal program, initiate transfer of the setting file created in step 2 above. (For example, with HyperTerminal, you would select *Transfer*, then *Send File*. Browse to find the file, then select *Open* and finally, *Send*.)
- 7 When the file has been transferred, verified and loaded, a message “New settings loaded and secure” is displayed.

A “serial number discrepancy” message may appear. This is to ensure that you are aware of the exact relay to which the settings are being loaded. If this happens, check the relay serial number using the terminal mode ID menu item. Type this serial number into the L-PRO Serial No. box in the Identification tab display area of *Offliner* Settings. Alternately you may check the Ignore Serial Number check box to bypass serial number supervision.

### Retrieve To *Offliner*

To transfer the relay’s current settings to the PC do the following:

- 1 Start L-PRO in Terminal Mode and login as view, change or service.
- 2 Navigate to *Settings>Retrieve To Offliner*.
- 3 Select *Enter*.
- 4 The relay asks you if you wish to continue. Select *Y* for yes.
- 5 The file is sent to the directory defined by the HyperTerminal menu *Transfer>Receive File*.

When using HyperTerminal if “Use receiving protocol:” is set to “Z modem with Crash Recovery”, file transfers are skipped by HyperTerminal if the record already exists in the downloads folder.

When using HyperTerminal use Z-modem (no crash recovery), files are received and auto-incremented.

## Metering

Submenus: Analog, External Inputs, Output Contacts, Logic.

For a detailed description see “Metering Data” on page 3-16

Analog	
Analog Inputs	Provide secondary values of the ac analog voltages and currents.
Line Quantities	Provide primary voltage kV phase–phase of each line.
External Inputs	Displays the current state of the External Inputs.
Output Contacts	Displays the current state of the Output Contacts.
Logic	
Protection	Protection Functions.
ProLogic	Provides the present status of the internal logic states. When a logic level becomes active, its state changes from low to high.
Setting Group	Displays current active Setting Group and Group Logic.
Virtual Inputs	Provide the present status of the virtual input logic states. When a logic level becomes active, its state changes from low to high.

## Records

Submenus - List, Fault Recording, Swing Recording, Event Recording.  
Contains the means for initiating and retrieving recordings.

List	Lists all records.
Fault Recording	Creates fault records.
Swing Recording	Creates swing records.
Event Recording	Creates event records.

### Retrieve Records from the Relay

To retrieve records from the relay do the following:

- 1 Start L-PRO in Terminal Mode and login as view, change or service.
- 2 Navigate to *Records>List* and press *Enter*; a records list appears.
- 3 Select *Records* using the space bar and select *R*. (You can also press *Enter* to retrieve a record directly.) The record will be saved in the directory specified by the terminal emulation program.

When using HyperTerminal if “Use receiving protocol.” is set to “Z modem with Crash Recovery”, file transfers are skipped by HyperTerminal if the record already exists in the downloads folder.

When using HyperTerminal use Z-modem (no crash recovery), files are received and auto-incremented.

### Delete Records from the Relay

To delete records from the relay do the following:

- 1 Start L-PRO in Terminal Mode and login as view, change or service.
- 2 Navigate to *Records>List* and press *Enter*.
- 3 Select the records for deletion with the space bar and select *D*. The selected records will be deleted.

## Event Log

The event log lists events stored in the relay. A complete list of the types of events logged is available, for details see “Event Messages” in Appendix D. For protection logic elements the event is logged only when the element changes from Low to High. For External Inputs, Virtual Inputs and Output Contacts, all changes of state are logged (Low to High, High to Low, Open to Closed, Closed to Open).

If an event triggered a record, then an (R) is displayed by the event.

**Utilities**

Sub-menus: Setup, Maintenance, Diagnostics.

Setup	
	Time - set manual time, IRIG-B skew control. Requires change or service access level.
	Ports - change Baud rates on communication ports. Requires change or service access level.
	SCADA - select which SCADA protocol (Modbus or DNP v3.0) to run on the SCADA port. Configure parameters for the selected protocol such as address or timeout. Requires change or service access level.
	External Inputs - Set the number of samples that an external input must be high in order for the external input to change, for details see "IED Specifications" in Appendix A.

Maintenance	
	Calibrate - calibrate all 18 analog inputs. Requires service access level.
	Outputs - close and open output contacts independent of the associated relay functions. Requires service access level.
	Control Virtual Inputs - set, reset and pulse virtual inputs. Pulse width is 1 second. Latched virtual inputs reset after pulse command has executed. Requires change or service access level.
	Erase - use submenus Records and Event Logs to erase these records from the relay memory. Requires change or service access level.

Diagnostics	
	Transfer Diagnostics - transfers relay diagnostic file to the PC. The diagnostic file can be sent to us for analysis.
	Modbus - allows Modbus Communications to enter its Diagnostic Mode. Follow directions on the screen. Programming done using the Modicon Modbus Protocol Reference Guide PI-MBUS-300 Rev. G published by Modicon, Inc., dated November 1994. For details see "Modbus RTU Communication Protocol" in Appendix E.

**Access**

Submenus: “view” Access, “change” Access, Password. Provides the ability

view	Changes the access level to view. Allows you read-only access to relay information.
change	Changes the access level to change. Allows you to modify settings and delete records.
Restriction	Allows you to limit change access to Port 1 only or cancel limitation.
Passwords	Allows you to read and change passwords. Requires service access level.

**Passwords**

Submenu: Password Update

**Password Update**

Password Update includes the submenus for all Access Levels password updates.

View	Password update for <b>view</b> login
Change	Password update for <b>change</b> login
Service	Password update for <b>service</b> login
Secadmin	Password update for <b>secadmin</b> login
Maintenance	Password update for <b>maintenance</b> login
Update	Password update for <b>update</b> login

**Syslog**

Submenu: Syslog Configuration

Syslog Configuration submenu allows configuration of Syslog server communication parameters as well as selection of “Host Name” field value in the unit Syslog message (see section 8 “Cyber Security”).

Modes of Syslog server operation are defined in the table below.

Mode	Description
Disabled	Communication with Syslog server is disabled
UDP	UDP protocol is used for communication with Syslog server

“IP Address” parameter defines Syslog server IP Address.

“Port” parameter defines Syslog server IP port for receiving Syslog messages.

“Host Name” parameter values are as follows.

Host Name	Description
Unit IP Address	Unit IP Address is used for Syslog message "Host Name" field
Unit Serial Number	Unit Serial Number is used for Syslog message "Host Name" field
Unit ID	Unit ID is used for Syslog message "Host Name" field

**Quit**

Selecting this option ends serial port communication with the relay.

**Metering Data****Front Panel Metering**

The quantities provided on the front panel display are the L-L voltage line currents, primary W, VARS, line-to-neutral quantities for the individual phases and frequency.

**TUI Metering**

The TUI provides the following metering quantities.

**Analog**

Analog Inputs – displays the magnitude and phase relationship of all the analog inputs.

Line Quantities – displays the primary line-to-line voltage, line current, MW, MVARs and system frequency.

**External Inputs**

Displays the status of all External Inputs.

**Output Contacts**

Displays the status of all Output Contacts.

**Logic**

Protection – displays the status of all internal logic.

ProLogic – displays the status of all ProLogic.

Group Logic – displays the status of all Group Logic and Active Setting Group.

Virtual Inputs – displays the status of all Virtual Inputs.

**I/O**

I/O metering shows the status of all external inputs and output contacts.



# 4 Protection Functions and Specifications

## Protection and Recording Functions

This section describes the equations and algorithms of the L-PRO Relay protection functions. All functions with time delay provide an alarm output when their pickup level is exceeded.

The following exceptions are: 27 Auxiliary, 27 Main, 59 Auxiliary, 59 Main, 25/27/59 Sync Check, 50LS Main, 50LS Auxiliary, 50BF Main, 50BF Auxiliary, 81 Frequency and ProLogic elements.

### 21P Phase/21N Ground Distance Mho

L-PRO has 4 zones of phase and 4 zones of ground distance protection elements. The 4 zones in the ground distance element (21N) can be set to either a Mho shape or quadrilateral shape, for details see “21N Ground Distance Quadrilateral” on page 4-5.

Zones 3 and 4 are set in both the forward and reverse direction as required. Set all the distance functions in secondary ohms. The available range of impedance settings is based on the hardware capabilities of the relay and the nominal current specified when ordered. The range is 0.05 to 66.00 ohms for a 5A nominal relay, and 0.25 to 330.00 ohms for a 1A nominal relay

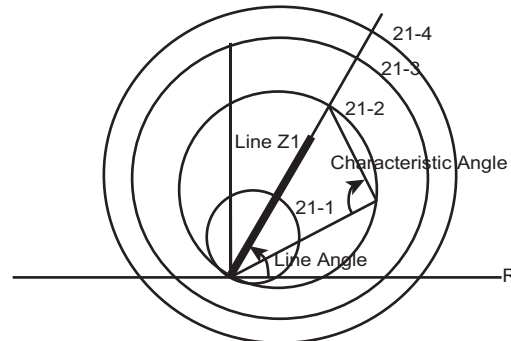

Figure 4.1: Phase and Ground Mho

The shape of the phase and ground distance relays is adjustable. For the circular Mho characteristic, the characteristic angle is 90 degrees. Determine this angle by drawing 2 lines from any point on the impedance locus to the diameter of the characteristic. Produce a tomato-shaped characteristic by selecting an angle less than 90 degrees or a lens-shaped characteristic with angles greater than 90 degrees.

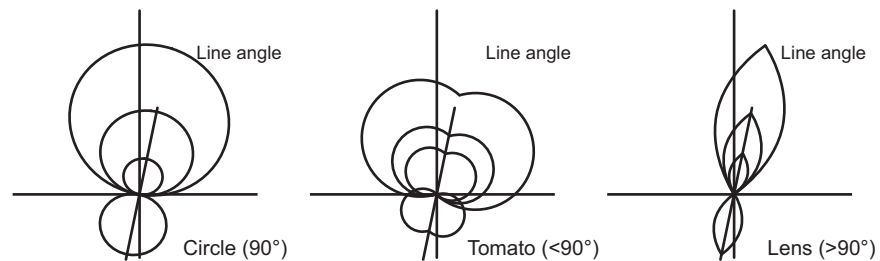

Figure 4.2: Mho Characteristic Shapes

The shape of the Mho characteristic means that significant extensions are made to the relay characteristics in the R region of the R-X plane for ground faults. You can restrict the reach in the R region for the phase distance relays where load encroachment is an issue. The shaped Mho characteristic provides the best fit for the application keeping the number of relay settings at a minimum and provides the benefits associated with the Mho characteristic.

The Mho characteristic used by the relay is developed by the classical approach using the measurement of the angle between 2 vectors.

These vectors are defined as:

$$A = I \times Z_{set} - V$$

$$B = V_{ref}$$

where  $V$  is the actual line voltage for ground distance relays or the actual line to line voltage for the phase distance relay.

$I$  is defined as:

$$I_{phase} + K_o \times 3I_0$$

for ground distance relays or the line to line current for phase distance relays.

$Z_{set}$  is the setting reach and  $V_{ref}$  is a positive sequence memory voltage stored within the relay.

$V_{ref}$  is the polarizing quantity for the mho elements, and is more completely described in “Relay Method of Memory Polarization” on page 4-5.

To make the reach of the ground distance relay relate to the line positive sequence impedance the classical  $K_o$  factor is used.

This factor is defined as:

$$K_o = \frac{Z_0 - Z_1}{3Z_1}$$

The L-PRO includes a directional element to supervise the phase (21P) and ground (21N) mho elements, for Zone 1 (21P1, 21N1) and Zone 2 (21P2, 21N2) only. The directional element prevents mis-operation of the mho elements for reverse faults, faults at the bus, and phase-phase faults during high load conditions. The directional element does not supervise Zone 3 and Zone 4 elements due to the offset reach capabilities of these zones. The directional element is described in “Directional Element” on page 4-7.

<b>21 P</b>				
	Zone 1	Zone 2	Zone 3	Zone 4
	Enable/disable	Enable/disable	Enable/disable	Enable/disable
Forward Reach (ohms)	0.05 to 66.00 (5 A) 0.25 to 330.00 (1 A)	0.05 to 66.00 (5 A) 0.25 to 330.00 (1 A)	0.05 to 66.00 (5 A) 0.25 to 330.00 (1 A)	0.05 to 66.00 (5 A) 0.25 to 330.00 (1 A)
Reverse Reach (ohms)			0.05 to 66.00 (5 A) 0.25 to 330.00 (1 A)	0.05 to 66.00 (5 A) 0.25 to 330.00 (1 A)
Mho Characteristic Angle (degrees)	70.0 to 140.0	70.0 to 140.0	70.0 to 140.0	70.0 to 140.0
Pickup Delay (seconds)	0.00 to 0.20	0.00 to 2.00	0.00 to 5.00	0.00 to 5.00
Id Supervision (amps secondary)	0.2 to 50.0 (5 A) 0.04 to 10.00 (1 A)	0.2 to 50.0 (5 A) 0.04 to 10.00 (1 A)	0.2 to 50.0 (5 A) 0.04 to 10.00 (1 A)	0.2 to 50.0 (5 A) 0.04 to 10.00 (1 A)
Line Angle (degrees)	45 to 89 Setting is made in Parameters. (Positive Sequence Angle.)			
Load Impedance (ohms)				
R (ohms secondary)	-150.0 to 150.0			
X (ohms secondary)	-150.0 to 150.0			

<b>21 N</b>				
	Zone 1	Zone 2	Zone 3	Zone 4
Characteristic Type	Mho/Quad	Mho/Quad	Mho/Quad	Mho/Quad
Forward Reach (ohms) (Mho characteristic)	0.05 to 66.00 (5 A) 0.25 to 330.00 (1 A)	0.05 to 66.00 (5 A) 0.25 to 330.00 (1 A)	0.05 to 66.00 (5 A) 0.25 to 330.00 (1 A)	0.05 to 66.00 (5 A) 0.25 to 330.0 (1 A)
Forward Reach (ohms) (Quad characteristic)	x to 66.00 (5 A) x to 330.00 (1 A)	x to 66.00 (5 A) x to 330.00 (1 A)	x to 66.00 (5 A) x to 330.00 (1 A)	x to 66.00 (5 A) x to 330.0 (1 A)
Reverse Reach (ohms) (Mho characteristic)			0.05 to 66.00 (5 A) 0.25 to 330.00 (1 A)	0.05 to 66.00 (5 A) 0.25 to 330.00 (1 A)
Reverse Reach (ohms) (Quad characteristic)			x to 66.00 (5 A) x to 330.00 (1 A)	x to 66.00 (5 A) x to 330.00 (1 A)
Left Reach (R1) (ohms) (Quad only)	0.05 to 66.00 (5 A) 0.25 to 330.00 (1 A)	0.05 to 66.00 (5 A) 0.25 to 330.00 (1 A)	0.05 to 66.00 (5 A) 0.25 to 330.00 (1 A)	0.05 to 66.00 (5 A) 0.25 to 330.00 (1 A)
Right Reach (R2) (ohms) (Quad only)	0.05 to 66.00 (5 A) 0.25 to 330.00 (1 A)	0.05 to 66.00 (5 A) 0.25 to 330.00 (1 A)	0.05 to 66.00 (5 A) 0.25 to 330.00 (1 A)	0.05 to 66.00 (5 A) 0.25 to 330.00 (1 A)
Mho Characteristic Angle (degrees)	70.0 to 140.0	70.0 to 140.0	70.0 to 140.0	70.0 to 140.0
Pickup Delay (seconds)	0.00 to 0.20	0.00 to 2.00	0.00 to 5.00	0.00 to 5.00
Id Supervision (amps secondary)	0.2 to 50.0 (5 A) 0.04 to 10.00 (1 A)	0.2 to 50.0 (5 A) 0.04 to 10.00 (1 A)	0.2 to 50.0 (5 A) 0.04 to 10.00 (1 A)	0.2 to 50.0 (5 A) 0.04 to 10.00 (1 A)
3IO Supervision (amps secondary)	0.2 to 50.0 (5 A) 0.04 to 10.0 (1 A)	0.2 to 50.0 0.04 to 10.0 (1 A)	0.2 to 50.0 0.04 to 10.0 (1 A)	0.2 to 50.0 0.04 to 10.0 (1 A)
Line Angle (degrees)	45 to 89 Setting is made in Parameters. (Positive Sequence Angle.)			
Load Impedance (ohms)				
R (ohms secondary)	-150.0 to 150.0			
X (ohms secondary)	-150.0 to 150.0			

$$x = R1 \bullet \cos(\text{LineAngle})$$

## 21N Ground Distance Quadrilateral

The L-PRO device 21N contains 4 zones of ground distance elements; all 4 zones of 21N can be set to either Mho or Quadrilateral type, note that only one type can be used at a time. The 21N can contain a mixture of Mho and quad shapes, for example the 21N1 and 21N2 can be set to a Mho characteristic and the 21N3 and 21N4 could be set to a quadrilateral characteristic.

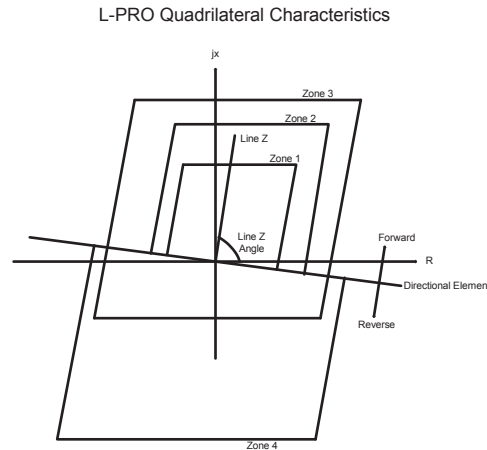

Figure 4.3: Ground Quadrilateral

The quadrilateral shape is parallel to the positive sequence line angle setting. The user-defined Mho Characteristic Angle is not selectable when you have defined a quadrilateral characteristic for that particular zone. All other settings are selectable and user-definable.

## Relay Method of Memory Polarization

The 21P and 21N mho elements use positive-sequence voltage, derived from a memory voltage, as the polarizing quantity. Sufficient positive-sequence voltage should be available during all fault events. However, during certain fault events, especially three-phase bolted faults near the line VT location, the positive-sequence voltage may be insufficient for correct operation. To ensure adequate positive-sequence voltage exists for all fault conditions, the L-PRO uses a ring filter, implemented in software, to provide memory voltage as the source for the positive-sequence voltage. This memory voltage lasts for approximately 150 cycles, even if all voltage inputs from the line VTs go to zero. A practical effect of using a memorized voltage is to expand the mho characteristic by the source impedance. This expansion of the characteristic ensures correct operation for zero voltage faults at the relay location, and for forward capacitive faults.

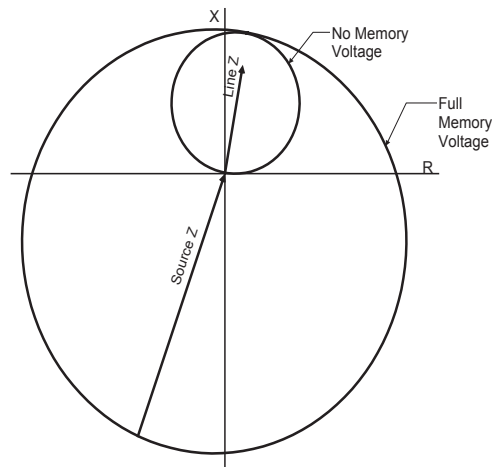

Figure 4.4: Effect of Using Memorized Voltage

### Ring Filter

The voltage memory in the L-PRO uses a ring filter implemented in software. The ring filter is a high-Q bandpass filter, with the frequency response centered on the nominal system frequency. The effect of the ring filter is to retain some voltage information for approximately 150 cycles, even if the measured system voltage is severely depressed by a fault.

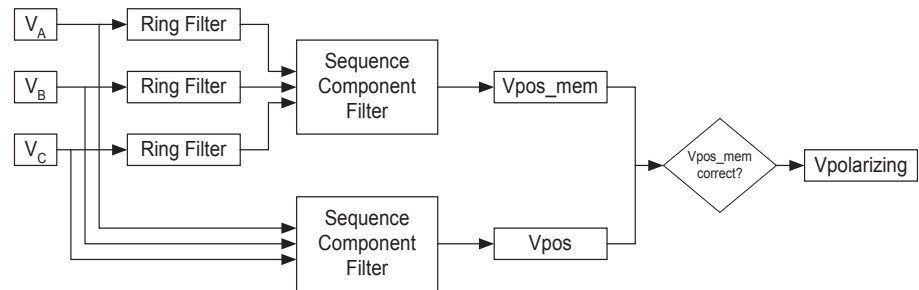

Figure 4.5: Polarizing Voltage

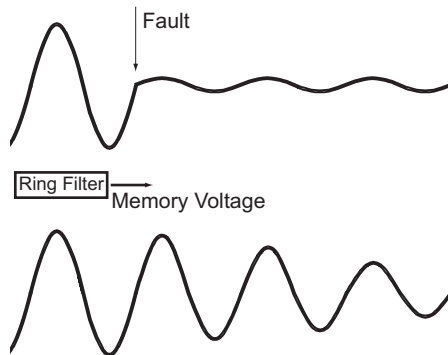

Figure 4.6: Effect of the Ring Filter

The ring filter is designed to adjust the center of the frequency response to account for small variations of the power system frequency. When the measured voltage drops below 0.5 Vsec, the ring filter explicitly uses the nominal system frequency as the center point of the bandpass filter. During this condition, or when the system frequency varies widely or rapidly, as during out-of-step conditions, the ring filter could provide an incorrect output. During these conditions, the 21P and 21N mho elements use the positive-sequence voltage derived from the system voltage directly from the line VTs until the voltage output of the ring filter is correct. If the measured positive sequence voltage is below 1 Vsec, then the mho elements use the positive sequence voltage derived from the memory voltage.

## Directional Element

The L-PRO includes a directional element that directly supervises the Zone 1 and Zone 2 phase and ground distance elements, the 50/51/67, 50N/51N/67N, 46-50/51/67 overcurrent elements, and the 50N/67F and 50N/67R elements in the Communications Aided Tripping schemes. The directional element considers negative-sequence impedance, zero-sequence impedance, or positive-sequence impedance, depending on relay settings and system conditions at the time of the fault. The element declares a forward fault when the impedance determined by the directional element is within  $90^\circ$  of the line impedance.

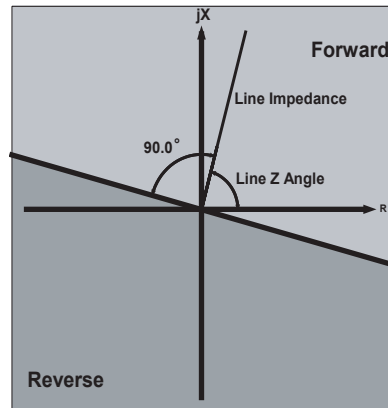

Figure 4.7: Fault Direction

The directional element in the L-PRO is always enabled. The directional element actually consists of three separate internal elements: a negative-sequence element, a zero-sequence element, and a positive-sequence element. The negative-sequence and zero-sequence elements use directly measured currents and voltages. The positive-sequence element uses directly measured current, and a memory voltage from the ring filter. The sensitivity for the negative- and zero-sequence elements may be set by the user, to correctly account for load conditions and system configuration. Both of these elements may be disabled as well. The positive-sequence element is always active.

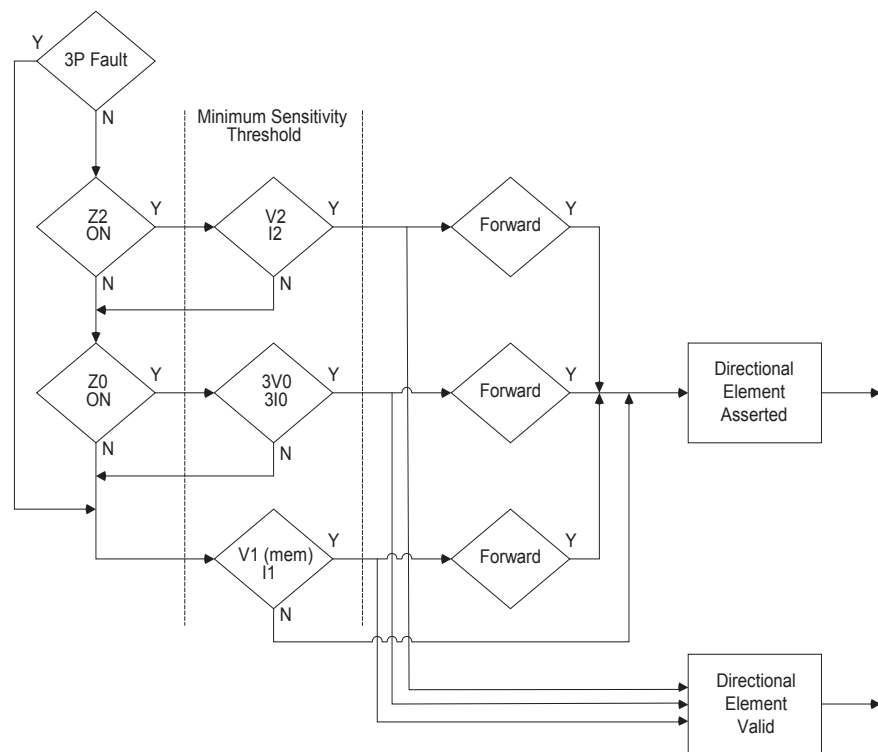

Figure 4.8: Directional Element Logic

For three-phase faults, the directional element will only use the positive-sequence element. For all other faults, the directional element will consider, in order, the negative-sequence calculation, the zero-sequence calculation, and the positive-sequence calculation. The directional element will only move from one calculation to the next calculation if insufficient sequence voltages and currents exist to make a valid calculation.

The negative-sequence calculation determines the angle between the measured negative-sequence impedance, and the positive-sequence line impedance angle entered in settings. To perform this calculation, the default minimum amount of negative-sequence voltage required is 0.5 Vsec, and the default minimum amount of negative-sequence current required is 0.2 Asec.

The zero-sequence calculation determines the angle between the measured zero-sequence impedance the zero-sequence line impedance angle entered in settings. To perform this calculation, the default minimum amount of zero-sequence voltage (3V0) required is 1.0 Vsec, and the default minimum amount of zero-sequence current (3I0) required is 0.2 Asec.

The positive-sequence calculation determines the angle between the measured positive-sequence impedance (based on measured current, and the memory voltage output of the ring filter) and the positive-sequence line impedance angle entered in settings. To perform the positive-sequence impedance calculation, the directly measured positive-sequence current must exceed 0.2 Asec, and the memorized positive-sequence voltage must exceed 2 Vsec.



There may be some rare circumstances where there may not be sufficient voltage or current, using the negative, zero, and positive sequence components, for the directional element to make a valid directional decision. The most likely circumstance where this may occur is a three-phase bolted fault near the line VTs, that isn't cleared in an appropriate amount of time. It takes approximately 30 cycles, after the measured three-phase system voltage drops to 0, for the ring filter voltage to decay such the  $V_{pos\_mem}$  is less than 2 Vsec. For this circumstance, or for any other fault case where there are insufficient sequence component quantities for any of the directional calculations to operate, the direction is set to "forward". Setting the directional element to forward explicitly sets the direction to forward for the distance elements, and for the 50N/67N-F and 50N/67N-R elements in the communications aided tripping schemes (effectively blocking the 50N/67N-R element), and allows all other directionally controlled elements to operate non-directionally.

### Directional Element Outputs

The output of the directional element asserts when the direction is determined to be "forward". This output is used internally by protection functions directly supervised by the element, and is also available as the "Directional Element" indication in ProLogic equations. The directional element also provides the "Directional Valid" output for use in ProLogic equations. This output asserts when any one of the active sequence impedance calculations has sufficient input quantities to make a valid direction determination, regardless of the actual direction. The "Directional Valid" output will always be asserted, except in the rare case where system voltage has gone to 0 for more than 30 cycles, as previously described. The 2 outputs can be combined in a ProLogic equation to a secure reverse directional output from the L-PRO, for example.

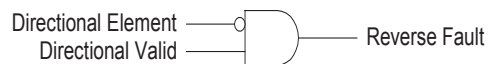

Figure 4.9: Directional Element

### Settings

The default setting of the directional element in the L-PRO should be correct for most applications. The default settings enable both the negative-sequence and zero-sequence calculations, with the minimum sensitivities as described. There are some applications where it may be advisable to change the sensitivity thresholds for the negative-sequence or zero-sequence calculations, or it may be desirable to disable one or both of these elements.

Selecting "Directional Element Override Enabled" allows user settings for the negative-sequence and zero-sequence directional elements.

The settings for the negative-sequence voltage sensitivity and negative-sequence current sensitivity should be normally higher than the maximum negative sequence quantities generated by unbalanced load. These settings should also be low enough to maintain sensitivity for the minimum unbalanced fault, in terms of negative sequence quantities.

The zero-sequence directional element can be used in many applications. However, where strong mutual coupling between parallel lines exist, the zero-sequence calculation must be disabled to prevent an incorrect directional determination. The sensitivity settings should be low enough to permit opera-

tion during the lowest expected ground fault in terms of zero-sequence quantities expected during a fault, and high enough to allow for normal load imbalance.

<b>Directional Element</b>	
Override Enabled	Enable / Disable
Negative-Sequence	Enable / Disable
V2 Sensitivity Level (volts secondary)	0.5 to 5.0
I2 Sensitivity Level (amps secondary)	0.1 to 1.0 (5A) 0.02 to 0.20 (1A)
3V0 Sensitivity Level (volts secondary)	1.0 to 10.0
3I0 Sensitivity Level (amps secondary)	0.2 to 2.0 (5A) 0.04 to 0.40 (1A)

## 21P and 21N Phase Selector

The phase selector algorithm for L-PRO ensures that:

- 21N only trips on single-phase-to-ground fault, so as to prevent 21N from false tripping for phase-to-phase-to-ground faults with arc resistance
- Supervise 21P for low SIR ratios and single-phase-to-ground faults at 20% of line reach or below.

### Algorithm Details

The phase selector uses a combination of positive, negative and zero sequence current phasors to correctly determine the faulty phase. An OR function with angle checks between I1 and I2 as well as the angle between I2 and I0. The OR functions allows the algorithm to adapt to various fault conditions and provide the correct fault type. When you are energizing a line with a T-tapped load, you may have system conditions where no pre-fault load current is available. Using positive and negative sequence currents alone may cause an incorrect fault determination if the load current is significantly large enough to affect the total positive sequence current, which includes both load and fault current.

### Angle Relationship of Positive and Negative Sequence Currents

The angle comparison scheme is used to determine the faulty phase and the fault type. If the load current is subtracted from the total current (i.e. only fault current is left for angle comparison), the positive sequence (I1) and negative sequence (I2) current phase angle relations are listed in the following table:

	AG Fault	BG Fault	CG Fault	BCG Fault	ABG Fault	CAG Fault
Angle Diff. between I1A and I2A	0	120	120	180	60	60
Angle Diff. between I1B and I2B	120	0	120	60	60	180
Angle Diff. between I1C and I2C	120	120	0	60	180	60

### Phase Selector Criteria for I1 and I2

The following criteria is used to determine the fault type and phase:

AG Fault:  $\text{AngleDiff\_A} < 45.0$  and  $\text{AngleDiff\_B} > 90.0$  and  $\text{AngleDiff\_C} > 90.0$

BG Fault:  $\text{AngleDiff\_B} < 45.0$  and  $\text{AngleDiff\_C} > 90.0$  and  $\text{AngleDiff\_A} > 90.0$

CG Fault:  $\text{AngleDiff\_C} < 45.0$  and  $\text{AngleDiff\_A} > 90.0$  and  $\text{AngleDiff\_B} > 90.0$

In the above criteria only one can become true at a time. They are used to supervise 21N\_A, 21N\_B, 21N\_C respectively.

### Angle Relationship of Negative and Zero Sequence Currents

The angle comparison scheme is used to determine the faulty phase and the fault type. The negative sequence ( $I_2$ ) and zero sequence ( $I_0$ ) current phase angle relations are listed in the following table:

	AG Fault	BG Fault	CG Fault	BCG Fault	ABG Fault	CAG Fault
Angle Diff. between $I_{2A}$ and $I_0$	0	120	120	0	120	120
Angle Diff. between $I_{2B}$ and $I_0$	120	0	120	120	120	0
Angle Diff. between $I_{2C}$ and $I_0$	120	120	0	120	0	120

### Phase Selector Criteria for $I_2$ and $I_0$

The following criteria is used to determine the fault type and phase:

AG Fault:  $\text{AngleDiff\_A} < 25.0$

BG Fault:  $\text{AngleDiff\_B} < 25.0$

CG Fault:  $\text{AngleDiff\_C} < 25.0$

Though AG type of fault will be declared for a BCG fault by the above angle criteria between  $I_2$  and  $I_0$ , the characteristic of AG impedance prevents AG from tripping because the phase selector is used for supervision only, i.e. the phase selector is not a tripping device.

### Device 21P Supervision

A 21P supervision logic is formed based on the above Phase Selector Criteria. The phase-to-phase distance element is only allowed to operate if the faulted phase is not involved with the element:

21P\_AB Supervision = Not AG Fault and Not BG Fault

21P\_BC Supervision = Not BG Fault and Not CG Fault

21P\_CA Supervision = Not CG Fault and Not AG Fault

### The Start of the Phase Selector

The phase selector starts only when a fault occurs. The start definition is: if  $3I_0$  is greater than the minimum of any enabled 21N zone's  $3I_0$  supervision level setting, begin the phase selector algorithm.

A buffer is used to track the pre-fault load current, which is subtracted from the total current before checking the phase selector criteria.

During fault conditions the system frequency may change causing a drift in the angle difference being calculated by the phase selector. The locked pre-fault load current vector is adjusted accordingly based on this angle difference between the pre-fault positive sequence voltage and the positive sequence voltage during the fault. If the faulted positive sequence voltage shifts, the angle difference is taken into account. (i.e. the same angle relationship remains along the fault duration.)

### Duration of the Phase Selector Supervision

The maximum blocking time to 21N for a phase-phase-ground fault is 2.0 seconds to x seconds, where x is the maximum pickup delay in enabled 21P2 to 21P4, and then plus 8 cycles (8 cycle is the maximum breaker opening time). This ensures that if 21P didn't trip on the phase-phase-ground fault for some reason, we allow 21N to trip on this fault after this maximum blocking time delay has expired.

### Ground Indicator in 21P Event Message

3I0 is checked against the minimum of the following settings:

- 21N1: 3I0 supervision when it's enabled
- 21N2: 3I0 supervision when it's enabled
- 21N3: 3I0 supervision when it's enabled
- 21N4: 3I0 supervision when it's enabled
- 50N Pickup level when it's enabled
- 51N Pickup level when it's enabled
- 50N\_67F when it's selected as Scheme\_Only or both ProLogic&Scheme

When 3I0 exceeds the minimum of the above values, a ground indicator "G" is put in the 21P event messages, e.g. "21P Trip ABG 123.1km"

### CCVT Transient Compensation on 21 Devices

When a fault occurs, especially on a line with high source to impedance ratio (SIR), the CCVT secondary voltage can become quite different from the actual system voltage varying in both magnitude and phase due to the transient response of the CCVT. This transient response can cause device 21 overreach significantly. A special CCVT transient compensation algorithm (Patent Pending) has been included in L-PRO 2100 relay to address this issue.

The CCVT transient compensation algorithm uses a combination of techniques with digital filters, vector averages and other means to rebuild the correct voltage from the transient distorted voltage waveforms. This combination of techniques provides a secure method for detecting and correcting CCVT transient phenomena. On one hand, it improves the reach accuracy of 21 devices dramatically during the period of the CCVT subsidence transient. On the other hand, it won't sacrifice the relay operation speed very much. It does not add any additional delay when the SIR is low (<1.2). In the worst case, it adds about one cycle delay when the SIR is high (>15). For the operation time details, refer to "IED Specifications" in Appendix A.

This compensation algorithm can be enabled or disabled through settings. Note that this algorithm is applied to all 21 devices once it's enabled. For the applications without CCVTs, this compensation algorithm should be disabled so as to eliminate the possible additional delay introduced by this algorithm.

## Line Energization Supervision Logic

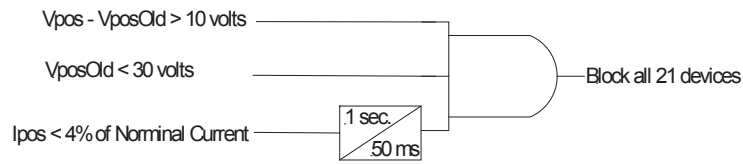

Note:  $V_{pos}$  is the present positive sequence voltage  
 $V_{posOld}$  is the positive sequence voltage at two cycles before

Figure 4.10: Line Energization Supervision Logic

This logic has been introduced in order to prevent potentially erroneous operations of the 21 upon energizing of T tapped transmission lines that have transformers connected and the PT connected on the line side of the breaker.

In this logic, the present positive sequence voltage is compared with the positive sequence voltage of 2 cycles previously. In an energization situation, the  $V_{posOld}$  would be near zero volts and the present  $V_{pos}$  would be approximately the nominal. As time goes by the old  $V_{pos}$  gets updated with the nominal voltage and would eventually equal the present. When it gets within 10 volts secondary the top input to the AND gate would reset, go to zero, and reset the blocking function.

The second input is the previous 2 cycle positive sequence voltage and has an undervoltage setting of 30 volts. This input goes high to block the distance relays only if the positive sequence voltage from 2 cycles back was less than 30 volts (approximately 50% nominal), so, for a line that has been previously energized and now experiences a fault, no distance relay blocking takes place.

The third input (the bottom one) produces an output only if the positive sequence line current is less than 4% nominal or 4.0% of 5 A secondary = 0.20 A secondary. If this current has been that low for the 1 second pickup time delay this input to the AND gate would go high. For a de-energized line this input would normally be high to allow the blocking scheme to operate if the other two inputs are high. This input along with input two are present to help prevent any distance relay blocking for a line that is in service and is now experiencing a line fault.

### 68 Out Of Step

Use the out of step (OOS) function as a tripping or a blocking function. This function consists of 2 sets of inner and outer impedance blinders on the R-X plane. Set the blinders to different values and to have the OOS function operate for different system conditions. The blinders are straight lines with the same angle as the angle chosen for the line positive sequence impedance. Outputs from the outer and the inner blinders are available on the output matrix for use with other types of OOS schemes or for monitoring.

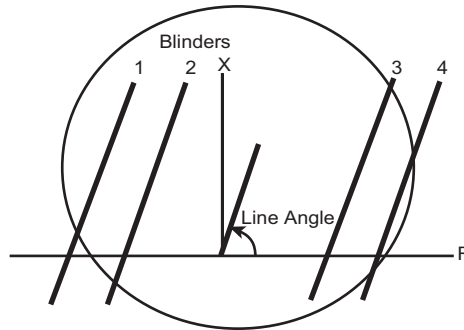

Figure 4.11: IaOS Overcurrent Supervision

The basic OOS scheme looks at the positive sequence impedance of the line with respect to the line loading. If the line loading causes the impedance to cross the outer blinder, an out of step timer is started. If the impedance does not cross the inner blinder before this timer times out, the function produces an output (either a block or trip—whichever is set) when the impedance crosses the inner blinder. The entire activity is supervised by an overcurrent function to prevent undesired operations for impedances far from the origin.

The logic has a timeout feature that prevents the blocking function from operating for an indefinite amount of time. Device 68 functions as either a blocking device or tripping device. The 68 Out of Step (68 Trip or 68 Block), 68 Inner and 68 Outer blinder logic points are available in the output matrix. These logic points are also logged as event messages in the event log, for details see “Event Messages” in Appendix D. In addition, the outputs from the inner and outer blinders are available for use with ProLogic to create any application scheme required.

If you select Device 68 to block for OOS conditions, the relay energizes the front panel alarm LED when the 68 elements are blocking. If you select the 68 to trip for OOS conditions the relay energizes the front panel target light.

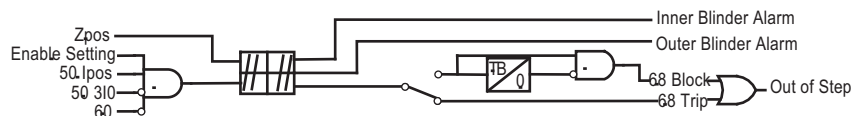

Figure 4.12: Out of Step

<b>68 Out of Step</b>	
Mode	Block, Off, Trip
Zone Blocking	
Zone 1 Blocking	Enable/disable
Zone 2 Blocking	Enable/disable
Zone 3 Blocking	Enable/disable
Zone 4 Blocking	Enable/disable
Out of Step Swing Timer	0.00 to 1.00 seconds
I1 Supervision	0.5 to 50.0 A secondary (5 A) 0.1 to 10.0 A secondary (1 A)
3I <sub>0</sub> Blocking	0.5 to 50.0 A secondary (5 A) 0.1 to 10.0 A secondary (1 A)
Blocking Reset Time	0.25 to 2.00 seconds
LHS Binder	
Outer (R1)	-100.0 to R2 ohms secondary (5 A) -500.0 to R2 ohms secondary (1 A)
Inner (R2)	R1 to R3 ohms secondary
RHS Binder	
Outer (R3)	R2 to R4 ohms secondary
Inner (R4)	R3 to 100.0 ohms secondary (5 A) R3 to 500.0 ohms secondary (1 A)



## Dead Line Pickup

When energizing a line that has been out of service, the line may have a fault on it. This function is called Dead Line Pickup or sometimes called switch on to fault. If the line potential is derived from bus PTs, the distance relay function acts normal and operates for any fault that exists when the line is energized. If the line uses line PTs, the output of these line PTs is zero. Because of this, operation of the line distance functions may be undefined. To provide protection to detect faults when a line is first energized, the dead line pickup function is involved.

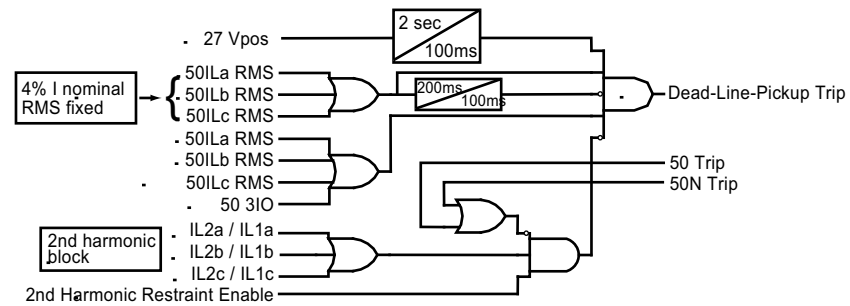

Figure 4.13: Dead Line Pickup

The Dead Line Pickup function uses voltage and current to determine whether the line is energized. The logic diagram shows how the circuit actually works. On energization the line voltage is zero allowing you to set the phase and neutral overcurrent relay function to trip if a fault is present on the line. These overcurrent functions must be set to see any faults at the end of the line.

When the line current of 4% of I nominal secondary or greater stays on for greater than 200 ms, the circuit is disabled, allowing the distance relays to take over protection of the line. If faults occur after the line has been energized, a voltage level of 75% could be present. The circuit does not react because of a 2 second delay on the voltage reset. No output from this function occurs because the blockout feature associated with the line current is greater than 0.2 A secondary.

If you are concerned about line current being less than 0.2 A secondary at any time during the inservice period, you can introduce a breaker auxiliary contact into the logic using a ProLogic statement (e.g. ProLogic Statement = Dead Line Pickup + External Input Breaker Closed). The breaker status can be either an “a” or “b” contact. Using the breaker contact supervision ensures no operation of the Dead Line Pickup function with the line breaker closed after the energization period.

In addition to this logic, a second harmonic restraint logic allows the line to be more easily energized if the line is T-tapped with an online reactor or transformer. Energization of the line with the T-tapped device results in 2nd harmonics that allows the line to be energized. If a fault exists that exceeds the line high set overcurrent devices, the line is allowed to trip.

<b>Dead Line Pickup</b>	
Dead Line Pickup	Enable/disable
Device 27 Vpos Pickup	0.0 to 69.0 volts secondary
Device 50 Pickup	0.5 to 50.0 A secondary (5 A) 0.1 to 10.0 A secondary (1 A)
Device 50N Pickup	0.5 to 50.0 A secondary (5 A) 0.1 to 10.0 A secondary (1 A)
Second Harmonica Restraint	Enabled/disabled
I2/I1 Ratio	0.0 to 10.0

### Weak Infeed

Weak Infeed provides tripping if fault levels are too low to activate the distance units. If enabled, this function sends a permissive trip signal even if the fault level seen by the relay is very low as when the line breaker is open. The positive sequence and zero sequence voltage detectors allow the relay to echo back a permissive signal to allow the end with fault current to trip quickly without the need for an auxiliary b contact.

<b>Weak Infeed</b>	
Weak Infeed	Enable/disable
Device 27 V1 Pickup	0.0 to 69.0 volts secondary
Device 59 V0 Pickup	0.0 to 100.0 volts secondary
Zone 2/Zone 4 Reset Delay (TWD1)	0.02 to 0.20 seconds
Communication Cycle Reset Delay (TWD2)	0.02 to 0.20 seconds
Communication Reset Time Delay (TW3)	0.02 to 100.0 seconds

**25/27/59 Sync Check**

The relay can bring in voltages from both line and bus PTs. The Line Sync Check function, if enabled, looks at the voltage steady state angle between the bus and the line PT voltage. If this angle is within a plus/minus specified value, (+/- 1 to 50 degree magnitude range of setting available), the function enables a definite time delay pickup (user-selectable 0 to 10.00 seconds) after which time an output is produced.

The line sync reference voltage is taken from a bus source. L-PRO can bring one single-phase to neutral voltage. Logic within the relay allows the single-phase quantity to be either A, B or C phase. All unused single-phase inputs must be grounded for proper operation.

The Dead Main Live Auxiliary, Live Main Dead Auxiliary and Dead Main Dead Auxiliary logic functions use fixed values of main and auxiliary positive sequence secondary voltages to determine the sync check condition. The voltage is fixed at 20 volts secondary, voltages below 20 volts are declared a dead state and voltages above 20 volts are declared a live state.

When enabled, this function checks that the voltage angle between the line PT and bus PT are within a specified value. You can use this function to ensure that closing a line to a system will result in acceptable power flow. The function uses positive sequence voltage, and therefore, can accommodate single-phase sources as well as 3-phase sources. If a single-phase source is used, it must be connected to the corresponding phase designation on the relay input. For example: If only a B-phase bus PT is available, it should be connected to the relay input B-phase terminals. In this example, the voltage and angle limit is 20 degrees with no pickup or drop out delay.

The Dead Main Live Auxiliary, Live Main Dead Auxiliary and Dead Main Dead Auxiliary logic functions use fixed values of main and auxiliary positive sequence secondary voltages to determine the sync check condition. The voltage is fixed at 20 volts secondary. Voltages below 20 volts are declared a dead state and voltages above 20 volts are declared a live state.

<b>25/27/59 Sync Check</b>	
25 Sync Check	Enable/disable
Maximum Voltage	60.0 to 138.0 volts secondary
Minimum Voltage	40.0 to 69.9 volts secondary
Angle Difference	1.0 to 50.0 degrees
Pickup Delay	0.00 to 10.00 seconds
Main/Aux	
Enable Dead Main Live Aux. (DMLA)	Enable/disable
Enable Live Main Dead Aux. (LMDA)	Enable/disable
Enable Dead Main Dead Aux. (DMDA)	Enable/disable

## 79 Recloser

The relay has a dedicated auto reclosure logic function. The recloser supports up to 4 shots of reclosing with complete ring bus circuit breaker control with or without synchronism check supervision or dead bus/dead line. Lead and follow breaker settings combined with out of service timers for each breaker are used to create flexible configuration options. The output matrix is used to map the inputs and outputs of the 79, the output for each reclose attempt is captured to the event log, and visual indication of an external recloser block condition (79B) is available on the front panel. The 79 requires breaker “a” contact status indication for each breaker.

For more information see “L-PRO Setting Example” in Appendix L.

### Open Interval Timers

The lead breaker open interval times are settable for each shot (T1–T4), while the follow breaker open interval is common for each shot attempt. The follow breaker open interval can use the 79 follower timer (TF), or the 79 reset timer (TD).

### Lead or Follow Breakers

The 79 adds flexible lead and follow breaker options, where the lead breaker can be in the main or auxiliary position. The 79 automatically moves the follow breaker into the lead position after the out-of-service time delay (TC), when the lead breaker is removed from service. If the follow breaker is removed from service, after the out-of-service time delay (TC), there is no follow breaker reclose attempts. When a TC timer has expired it does not reset until the breaker status changes for at least 10.0 seconds or the relay is powered down.

### External Reclose Blocking

The 79 also supports blocking from external devices via the output matrix and the internal 79 Lockout indication. You can control the 79 remotely or locally with external or virtual inputs.

### Lockout Indication

Lockout indication is provided for the lead and follow breaker. The lead and follow lockout indication is set for a fixed time delay pickup of the close signal time (TP) plus 1.0 second. When the recloser goes to the lead lockout condition, the breaker out of service timers are set to zero seconds and automatically pick up. If the recloser is in the lead lockout state, the logic remains in that state for setting (TD) seconds after the main or auxiliary breaker is manually closed. The follow lockout condition occurs when the follow breaker receives a close signal and the breaker remains open. If the recloser is in the follow lockout state, the logic remains in that state for setting (TD) seconds after the follow breaker is manually closed.

<b>79 Recloser</b>	
79 Recloser	Enable/disable
Number of Shots	1 to 4
First Reclose (T1)	0.1 to 999.9 seconds
Second Reclose (T2)	1.0 to 999.9 seconds
Third Reclose (T3)	1.0 to 999.9 seconds
Fourth Reclose (T4)	1.0 to 999.9 seconds
Close Time (Tp)	0.1 to 1.0 seconds
Lockout Time (TD)	0.0 to 999.9 seconds
Initiate Reset (TDI)	0.0 to 999.9 seconds
Recloser Mode	Main only
Block Reset (TDB)	0.0 to 999.9 seconds
Follower Time (TF)	0.0 to 24.9
Breaker Out of Service (TC)	0.0 to 999.9 seconds
Follower Sequence Switch	
Close after the Recloser Follower Time (TF)	On/off
Close after the Recloser Reset Time (TD)	On/off
Sync Control	Enabled/disable

The recloser provides flexibility with lead and follow breaker options. The lead breaker is in the main or auxiliary position. This allows you to control the lead circuit breaker with complete Dead Main Live Auxiliary, Live Main Dead Auxiliary, Dead Main Dead Auxiliary or Live Main Live Auxiliary supervision (angle limit and voltage limit). You also have the ability to control the 79 remotely or locally with external or virtual inputs. The 79 recloser monitors the breaker contact “a” status and automatically moves the follow breaker into the lead position when the lead breaker is removed from service, after an out-of-service time delay setting. For details of auto-recloser examples see “L-PRO Setting Example” in Appendix L.

### Sync Control

The flexibility provided with device 79 allows you to control 1 or 2 circuit breakers with complete Dead Main Live Auxiliary, Live Main Dead Auxiliary, Dead Main Dead Auxiliary or Live Main Live Auxiliary supervision (slip frequency). Sync control is provided on the lead breaker only, because the follow breaker always recloses after the lead breaker has successfully closed. ProLogic can be used to supervise follow breaker closing attempts if an external input is used to signal that the follow breaker has a valid sync check signal from an external device (e.g. PLC).

### 59 Main/Auxiliary Overvoltage

L-PRO provides overvoltage protection from both the bus and line PTs. These functions are definite time delay functions.

Gate Switch (Setting)

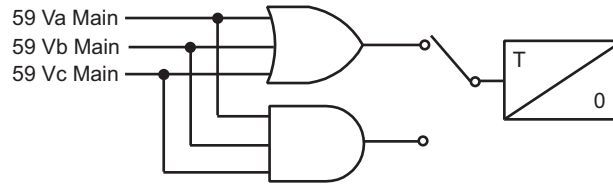

Figure 4.14: 59 Main Overvoltage

The definite time delay main overvoltage function, similar to the undervoltage function, looks at all 3 phase-to-neutral voltages. This function uses the RMS voltages to make this determination of overvoltage and is settable to an AND or OR logic.

The auxiliary overvoltage function operates exactly the same way as the main overvoltage function except that it uses the voltages from the auxiliary PT inputs.

59 Overvoltage	
Main	Enable/disable
Gate Switch	AND or OR
Pickup	1.0 to 138.0 volts secondary
Pickup Delay	0.00 to 10.00 seconds
Auxiliary	Enable/disable
Gate Switch	AND or OR
Pickup	1.0 to 138.0 volts secondary
Pickup Delay	0.00 to 10.00 seconds

## 27 Main/Auxiliary Undervoltage

L-PRO provides undervoltage protection from both the bus and line PTs. These functions are definite time delay functions.

The definite time main undervoltage function looks at the phase-to-neutral voltage of all 3 phases to determine an undervoltage condition. The fundamental RMS voltage is used for this calculation. If any of the phase-to-neutral voltages is below the set value, the function starts the definite time delay timer. You can set this function to be an AND or OR logic.

The auxiliary undervoltage function operates exactly the same way as the main undervoltage function except that it uses the voltages from the auxiliary PT inputs.

### Gate Switch (Setting)

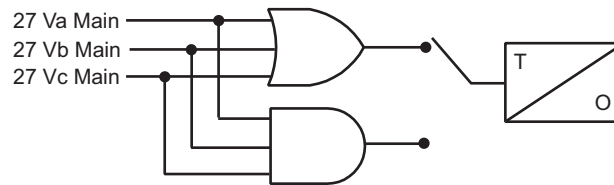

Figure 4.15: 27 Undervoltage

27 Undervoltage	
Main	Enable/disable
Gate Switch	AND or OR
Pickup	1.0 to 120.0 volts secondary
Pickup Delay	0.00 to 10.00 seconds
Auxiliary	Enable/disable
Gate Switch	AND or OR
Pickup	1.0 to 120.0 volts secondary
Pickup Delay	0.00 to 10.00 seconds

## 60 AC Loss of Potential

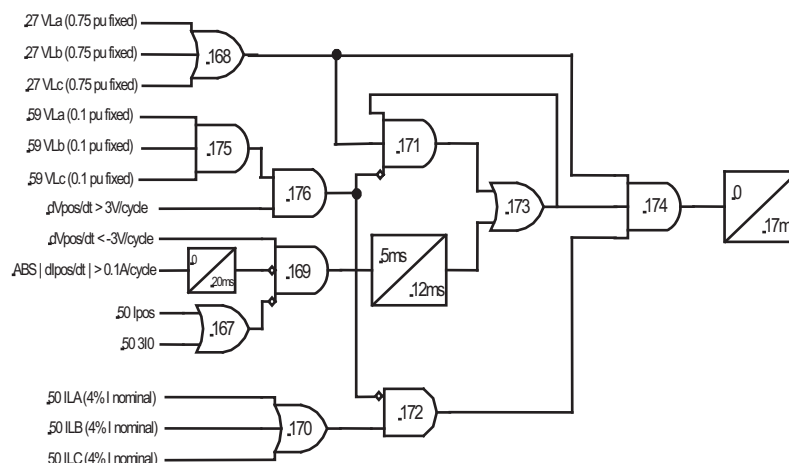

Figure 4.16: Loss of Potential

The L-PRO distance elements (21P and 21N) are supervised by both instantaneous non-directional overcurrent and the loss of potential (LOP) logic to prevent false trip due to the loss of potential, where the phase distance elements are supervised by the delta current (i.e. Ia-Ib, Ib-Ic and Ic-Ia), and the ground distance elements are supervised by both the phase current and the zero sequence (3I0) current.

The loss of potential (LOP) function uses rate of change values for the positive sequence voltage and current signal along with voltage and current supervision to detect loss of potential conditions. This function operates very fast and been field proven to block the distance elements during potential transferring between buses.

The function looks for a negative rate of change on the positive sequence voltage while determining if the positive sequence current is changing. A loss of potential in itself should result in only a loss of voltage or a negative rate of change of voltage. A fault results in a high rate of change of current as well. In some rare cases there is a negative rate of change of fault current, therefore we use an absolute rate of change of current. When the loss of potential condition is detected, it is latched until all the 3-phase voltages are above 75% or a positive rate of change of voltage is detected. So the circuit detects a loss of potential that results in a voltage of less than 75%. Select positive and zero sequence current blocking functions above the maximum load current, this ensures that LOP does not pick up on fault.

A dropout timer has been added on the di/dt signal (in front of gate 169) to ensure that the di/dt signal won't reset earlier than the dv/dt signal. This change improves the security of the algorithm in some particular fault situations.

60 Loss of Potential	
60 Loss of Potential	Enable/disable
I1 Blocking	0.5 to 50.0 A secondary (5 A) 0.1 to 100.0 A secondary (1 A)
3I0 Blocking	0.5 to 50.0 A secondary (5 A) 0.1 to 100.0 A secondary (1 A)



If this function is enabled and an AC Loss of Potential takes place, an output contact can be closed.

Loss of potential causes an alarm and distance elements will be blocked. Positive and Zero sequence current settings provided will block this function for faults. If voltage goes below 75% nominal (49.8 volts) and the currents obtained do not exceed the settings, the loss of potential will be initiated.

Note that the positive and zero sequence current blocking level should be set above the maximum line current. This function is fast enough to provide blocking of the distance functions for schemes that use bus potential inputs that are sometimes transferred without the need for any external blocking inputs.

Logic Element	Description (for details see Figure 4.16: Loss of Potential on page 4-24)
167	When 50Ipos or 503I0 exceed their set point and go high (1) it will invert and block logic element 169
168	When one of the phase-to-ground potentials falls below 0.75 pu, the logic element's output is high.
169	To declare a LOP, this element must have a negative rate of change of positive sequence voltage below or less than 3 volts/cycle - AND - an absolute value of rate of change of positive sequence current below or less than 0.1 A/cycle - AND -not have a positive sequence load current (50 Ipos) above the setting.- OR - not have 3 times zero sequence fault current (3I0) above the setting of 3I0.
170	LOP is declared by this logic element (logic high) when any of the phase currents are above 0.2 A.
171	Has an output when o/p from 168 is high - AND - o/p from logic 173 is high - AND - "NOT" logic 176 high. (Positive sequence rate of change voltage is not greater than 3 volts/cycle and not 3 phase voltage greater than 0.1 pu).
172	Has an output when o/p from 170 is high - AND - positive sequence rate of change voltage is not greater than 3 volts/cycle.
173	Has an output when o/p from 171 is high - OR - timed o/p from logic 169 is high.
174	Has a Loss of Potential (LOP) output when o/p from 168 is high - AND - o/p from logic 172 is high - AND - o/p from logic 173 is high. The output is timed on drop out. This output is sent to other elements of the relay to give indication and block voltage elements, such as impedance from tripping falsely from loss of potential condition.
175	Phase voltage AØ and BØ and CØ greater than 0.1pu will have output HIGH
176	Logic element 175 HIGH AND positive sequence rate of change voltage is not greater than 3 volts/cycle - output HIGH, will invert into element 171 to Block tuning 171 off.

## 81 Frequency

The relay has 4 frequency devices available. Each frequency element can be set to operate either at a fixed level of under-frequency, a fixed level of over-frequency, or at a rate of change level ( $df/dt$ ). The  $df/dt$  function can be set to operate for a positive rate of change or a negative rate of change. Each frequency element has a definite time delay setting to create a time delayed output. A fixed level of positive sequence voltage of 0.25 pu provides an undervoltage inhibit on each element

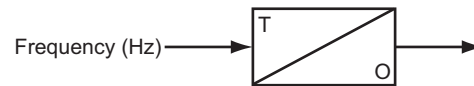

Figure 4.17: Frequency Fixed Level

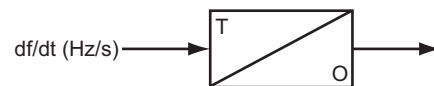

Figure 4.18: Frequency Rate of Change

81 Over/Under Frequency	
81-1	Disabled/Fixed Level/Rate of Change
Pickup	50.000 to 59.995 or 60.005 to 70.000 (fixed level) -10.0 to -0.1 or 0.1 to 10.0 (rate of change)
Pickup Delay	0.05 to 99.99 seconds (fixed level) 0.20 to 99.99 seconds (rate of change)
81-2	Disabled/Fixed Level/Rate of Change
Pickup	50.000 to 59.995 or 60.005 to 70.000 (fixed level) -10.0 to -0.1 or 0.1 to 10.0 (rate of change)
Pickup Delay	0.05 to 99.99 seconds (fixed level) 0.20 to 99.99 seconds (rate of change)
81-3	Disabled/Fixed Level/Rate of Change
Pickup	50.000 to 59.995 or 60.005 to 70.000 (fixed level) -10.0 to -0.1 or 0.1 to 10.0 (rate of change)
Pickup Delay	0.05 to 99.99 seconds (fixed level) 0.20 to 99.99 seconds (rate of change)
81-4	Disabled/Fixed Level/Rate of Change
Pickup	50.000 to 59.995 or 60.005 to 70.000 (fixed level) -10.0 to -0.1 or 0.1 to 10.0 (rate of change)
Pickup Delay	0.05 to 99.99 seconds (fixed level) 0.20 to 99.99 seconds (rate of change)

Four frequency elements are provided with adjustable definite time delays. Frequency is determined from the main voltage input (3 phase voltage).

**50LS Overcurrent**

L-PRO takes in currents from 2 ring bus CTs and 2 additional CT inputs, 50LS Input 3 and 50LS Input 4. These individual overcurrent devices can be used with ProLogic to create your own logic. 50LS Input 3 and 50LS Input 4 are not available in the Output Matrix.

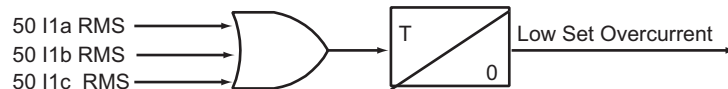

Figure 4.19: Low Set Overcurrent

50 Low Set Overcurrent	
Main	Enable/disable
Pickup	0.10 to 50.00 A secondary (5 A) 0.02 to 10.00 A secondary (1 A)
Pickup Delay	0.00 to 10.00 seconds
Auxiliary	Enable/disable
Pickup	0.10 to 50.00 A secondary (5 A) 0.02 to 10.00 A secondary (1 A)
Pickup Delay	0.00 to 10.00 seconds

### 50BF Breaker Failure

The breaker failure protection function detects breaker failures. There are 2 sets of breaker failure protection functions, 50BF Main and 50BF Auxiliary, one for each breaker. When breaker failure is initiated by a trip or other internal logic (user-settable through the output matrix) and the breaker current still exists, 2 timers (T1 and T2, user-settable) are started. When these timers are timed out and if the current still exists (which indicates breaker failure), the output of this function is set high. Use the 2 outputs of this function to trip another trip coil or the next level of breakers, such as bus breakers. Phase current supervision is fixed at 4% of I nominal and is shown for a 5 A relay.

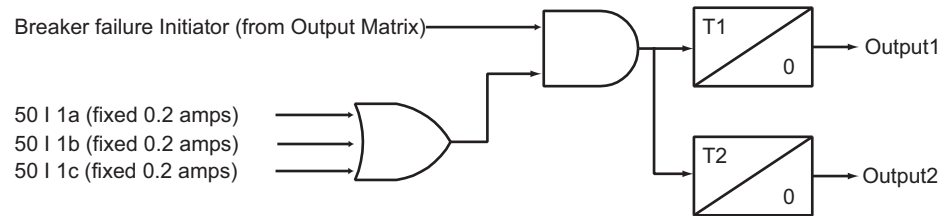

Figure 4.20: 50BF Main Breaker Failure

50 Breaker Failure	
Main	Enable/disable
Pickup Delay 1	0.01 to 99.00 seconds
Pickup Delay 2	0.01 to 99.00 seconds
Auxiliary	Enable/disable
Pickup Delay 1	0.01 to 99.00 seconds
Pickup Delay 2	0.01 to 99.00 seconds

## 50/51/67 Phase Overcurrent

Phase Overcurrent provides backup protection to the line. You can define forward, reverse or non directional control on either 50 or 51 functions.

Device 51 provides 3 IEC inverse time curve types, 3 IEEE inverse time types of overcurrent protection and one user-defined curve. The equation and the parameters of Device 50/51/67 are listed below.

**Table 4.1: IEC and IEEE Curves**

No	Curve Type	A	B	p	TR
1	IEC Standard Inverse	0.14	0.00	0.02	13.5
2	IEC Very Inverse	13.50	0.00	1.00	47.3
3	IEC Extremely Inverse	80.00	0.00	2.00	80
4	IEEE Moderately Inverse	0.0103	0.0228	0.02	0.97
5	IEEE Very Inverse	3.922	0.0982	2.00	4.32
6	IEEE Extremely Inverse	5.64	0.0243	2.00	5.82
7	User-defined	[0.001, 1000]	[0.0, 10.0]	[0.01, 10.0]	0.1, 100

For I > pickup	For I < pickup
$T(I) = TMS \left[ B + \frac{A}{\left( \frac{I}{Pickup} \right)^p - 1} \right]$	$T(I) = TMS \left[ \frac{TR}{\left( \frac{I}{Pickup} \right)^2 - 1} \right]$

50/51/67 Phase Overcurrent	
50	Enable/disable
Directional	Forward, reverse or non-directional
Pickup	0.50 to 50.00 (5 A) 0.10 to 10.00 (1 A)
Pickup Delay	0.00 to 99.99 seconds non-directional 0.01 to 99.99 seconds directional
51	Enable/disable
Directional	Forward, reverse, non-directional
Pickup	0.50 to 50.00 (5 A) 0.10 to 10.00 (1 A)
Curve Type	For details see for details see Table 4.1: IEC and IEEE Curves on page 4-29.
TMS	0.01 to 10.00
A	0.0010 to 1000.0000
B	0.0000 to 10.0000
p	0.10 to 10.00
TR	0.10 to 100.00

**50N/51N/67 Neutral Overcurrent**

Neutral overcurrent provides backup protection for line to ground faults. You can define forward, reverse or non-directional control on either 50N or 51N functions. 51N can also be configured for use in the communication scheme. All the curve definitions are the same as the phase overcurrent except that this function uses 3I0 rather than phase current. The equation is:

For 3I0 > pickup	For 3I0 < pickup
$T(3I0) = TMS \left[ B + \frac{A}{\left( \frac{3I0}{Pickup} \right)^p - 1} \right]$	$T(3I0) = TMS \left[ \frac{TR}{\left( \frac{3I0}{Pickup} \right)^2 - 1} \right]$

<b>50N/51N/67 Neutral Overcurrent</b>	
50N	Enable/disable
Directional	Forward, reverse or non-directional
Pickup (3I0)	0.50 to 50.00 (5 A) 0.10 to 10.00 (1 A)
Pickup Delay	0.00 to 99.99 seconds non-directional 0.01 to 99.99 seconds directional
51N	Enable/disable
Directional	Forward, reverse, non-directional, forward & in scheme
Pickup (3I0)	0.50 to 50.00 (5 A) 0.10 to 10.00 (1 A)
Curve Type	For details see Table 4.1: IEC and IEEE Curves on page 4-29.
TMS	0.01 to 10.00
A	0.0010 to 1000.0000
B	0.0000 to 10.0000
p	0.10 to 10.00
TR	0.10 to 100.00

### 46-50/46-51/67 Negative Sequence Overcurrent

Negative Sequence Overcurrent provides further backup protection for any unbalanced faults. You can define forward, reverse or non-directional control on either 46-50 or 46-51 functions. All the curve definitions are the same as the Phase Overcurrent. The only difference is that this function uses the negative sequence current ( $I_2$ ) rather than phase current. The equation is:

For $I_2 > \text{pickup}$	For $I_2 < \text{pickup}$
$T(I_2) = TMS \left[ B + \frac{A}{\left( \frac{I_2}{\text{Pickup}} \right)^p - 1} \right]$	$T(I_2) = TMS \left[ \frac{TR}{\left( \frac{I_2}{\text{Pickup}} \right)^2 - 1} \right]$

46-50/46-51N/67 Negative Sequence Overcurrent	
46-50	Enable/disable
Directional	Forward, non-directional
Pickup	0.50 to 50.00 (5 A) 0.10 to 10.00 (1 A)
Pickup Delay	0.00 to 99.99 seconds non-directional 0.01 to 99.99 seconds directional
46-51	Enable/disable
Directional	Forward, reverse, non-directional
Pickup	0.50 to 50.00 (5 A) 0.10 to 10.00 (1 A)
Curve Type	For details see for details see Table 4.1: IEC and IEEE Curves on page 4-29.
TMS	0.01 to 10.00
A	0.0010 to 1000.0000
B	0.0000 to 10.0000
p	0.10 to 10.00
TR	0.10 to 100.00

### Adaptive Additional Delay for 50 O/C Elements

The L-PRO provides an adaptive additional time delay (maximum 16 ms) response to the 50 O/C elements to prevent operation during RFI testing with minimal pickup set points and operation near pickup.

This adaptive delay is applied to: 50LS-1, 50LS-2, 50LS-3, 50LS-4, 50, 50N, 46/50.

If the Pickup Delay setting ( $T_p$ ) < 20ms AND Pickup Level setting < Inominal (nominal current), an extra 8 ms delay is added. After this 8 ms timer expires, if  $I < \text{threshold}$ , the second 8ms extra delay will be added in addition to the original  $T_p$ . If  $I > \text{threshold}$  after the first 8ms timer expires, only  $T_p$  is used for the delay. (Note  $T_p$  is the setting which is less than 20ms, could be 0ms).

The threshold is equal to  $2 * \text{PickupLevel}$  if pickup is between  $40\% * \text{Inominal}$  and  $\text{Inominal}$  (i.e. between 2A and 5A for 5ACT). The threshold is equal to  $40\% * \text{Inominal}$  if  $2 * \text{PickupLevel} < 40\% * \text{Inominal}$ . The threshold is equal to  $\text{Inominal}$  if  $2 * \text{PickupLevel} > \text{Inominal}$ .

### Directional Control

Directional overcurrent elements use the same directional element as the mho distance elements. Overcurrent elements will operate depending on directional setting and fault direction, when the directional element has a valid output. If the directional element can not declare a valid direction, overcurrent elements will operate as non-directional elements. See “Directional Element” on page 4-7.

### Z Circle Trigger

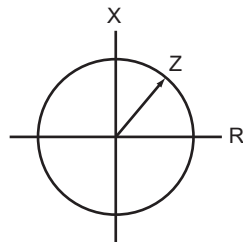

Figure 4.21: Z Circle Trigger

Z Circle Trigger	
Z Circle Trigger	Enable/disable
Positive Sequence Impedance	0.1 to 50.0 ohms secondary (5 A) 0.5 to 250.0 ohms secondary (1 A)

The Impedance Circle Trigger (Z Circle Trigger) triggers the relay to record on a dynamic swing disturbance—only used to trigger a recording. This trigger is usually set outside the last protection zone used and blocked during LOP conditions.



---

**Fault Locator**

Whenever a fault occurs and the line trips, the fault locator calculates the fault type and the distance to the fault. This information is available from the front display of the relay or through Port 1, 2 or the SCADA port. Fault locator can be enabled/disabled through settings (system parameters).

The fault locator is initiated by the following logic:

- 21 Trip
- 50N Trip
- 51N Trip
- Scheme Trip
- 21 Alarm (configurable)

## ProLogic

### ProLogic Control Statements

Using ProLogic, L-PRO can pick any of the protection functions, external inputs or virtual inputs and place them into Boolean-like statements. ProLogic handles up to 5 functions to generate one ProLogic statement; 12 statements are possible. The results from these statements are mapped to output contacts using the output matrix.

Special ProLogic inputs are:

- Communications receive input from ProLogic output.
- Output relay #14 as an input to ProLogic.

The ProLogic control statements are used to create Boolean-like logic. The L-PRO can use any of the protection functions or external inputs combined with logic gates to create a ProLogic control statement. The possible gates are AND, NAND, OR, NOR, XOR, NXOR, and LATCH. The control can be time delay pickup and or time delay dropout, and can drive the front panel target LED. Twelve ProLogic control statements outputs are available and can be used in the output matrix to customize the relay to your specific needs. Inputs to ProLogic are all the elements plus previous ProLogic statements for logic nesting usage.

The example shows A to E inputs are status points of devices that are user-selectable. Each ProLogic output can be given a specific name, pickup and reset time delay.

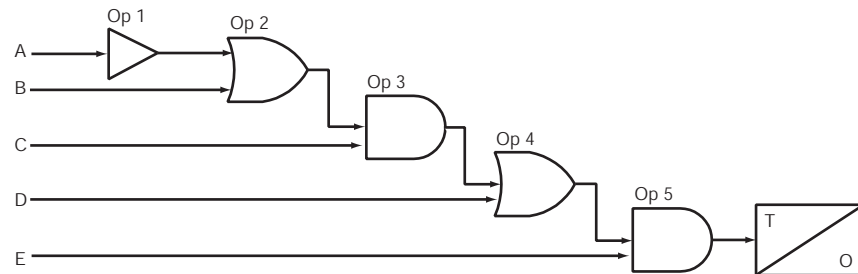

Figure 4.22: ProLogic

ProLogic Setting Functions	
Name	Give the ProLogic a meaningful name
Pickup Delay	Delay time from pickup to operate
Dropout Delay	Delay time from dropout to a ProLogic status of low
A, B, C, D, E	Relay elements as input statements
Operators	Boolean-type logic gates

---

## Group Logic

### Group Logic Control Statements

The L-PRO Relay has 8 setting groups (SG). You can change all relay setting parameters except the physical connections such as input or output parameters in each setting group. Setting group changes are performed by using any one of the 16 available Group Logic statements per setting group. The Group Logic statements are similar to the ProLogic statements with the following exceptions—the sole function is to activate one of the 8 setting groups and the processing is in a slower half second cycle. Group Logic inputs statements are driven from ProLogic or any external input or virtual input or from previous Group Logic statements. Each Group Logic statement includes 5 inputs (with Boolean statements), one latch state and one pickup delay timer. The active setting group (ASG) is viewed from the Terminal Mode, the front panel or from a record stored by the relay (the active setting group is stored with the record).

### Group Logic Processing

The 16 Group Logic statements reside in a slower processing thread within the relay protection algorithms. The processing cycle happens once every half second (0.5 second). When using ProLogic statements remember that a latch or dropout timer should be used if the initiating condition does not last at least 0.5 seconds. In the example following, we will create a definite pulse length using ProLogic, for details see “L-PRO Setting Example” in Appendix L.

### Default Setting Group

The relay uses Setting Group 1 as the factory default setting group and retains the current active setting group in memory. This allows the relay to use the last active setting group prior to interruption of relay power as the default setting group following power up.

### Change Active Group

You can at any time change the active setting group. When you initiate a setting group change, this change takes precedence over an automatic setting group change. The terminal UI is used to change the active setting group. To view a snapshot of the group logic data select F2 prior to making any modification to the Active Setting Group input. The following is the flow of events that can occur in the Active Group Screen.

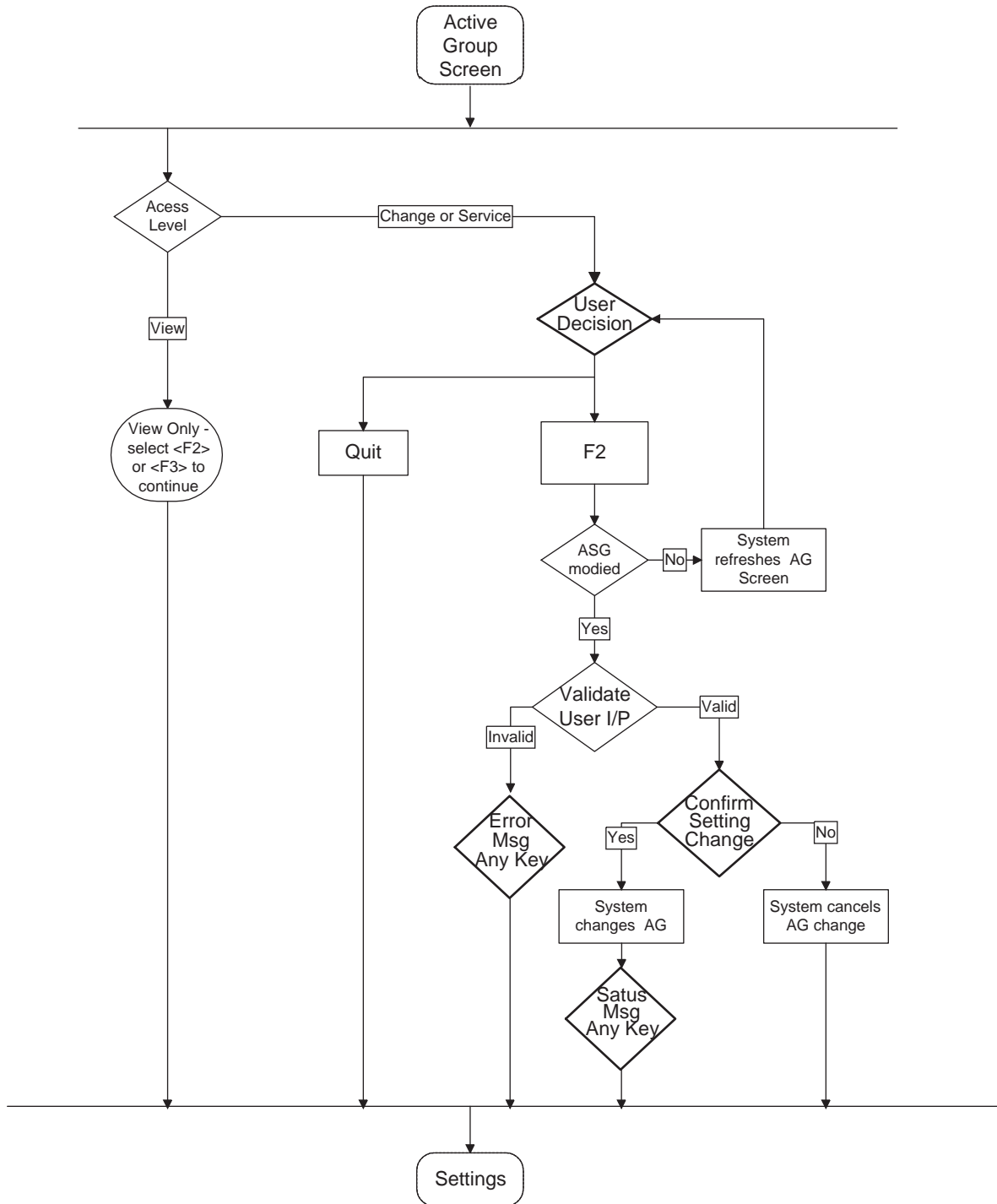

### Settings Saved

You can change the active setting group while saving setting changes or loading settings from *Offliner*. The relay prompts you for a setting group to activate—you can keep the current setting group or switch to a new setting group following the settings save.

The following is the flow of events that can occur in the Editing Settings Screen.

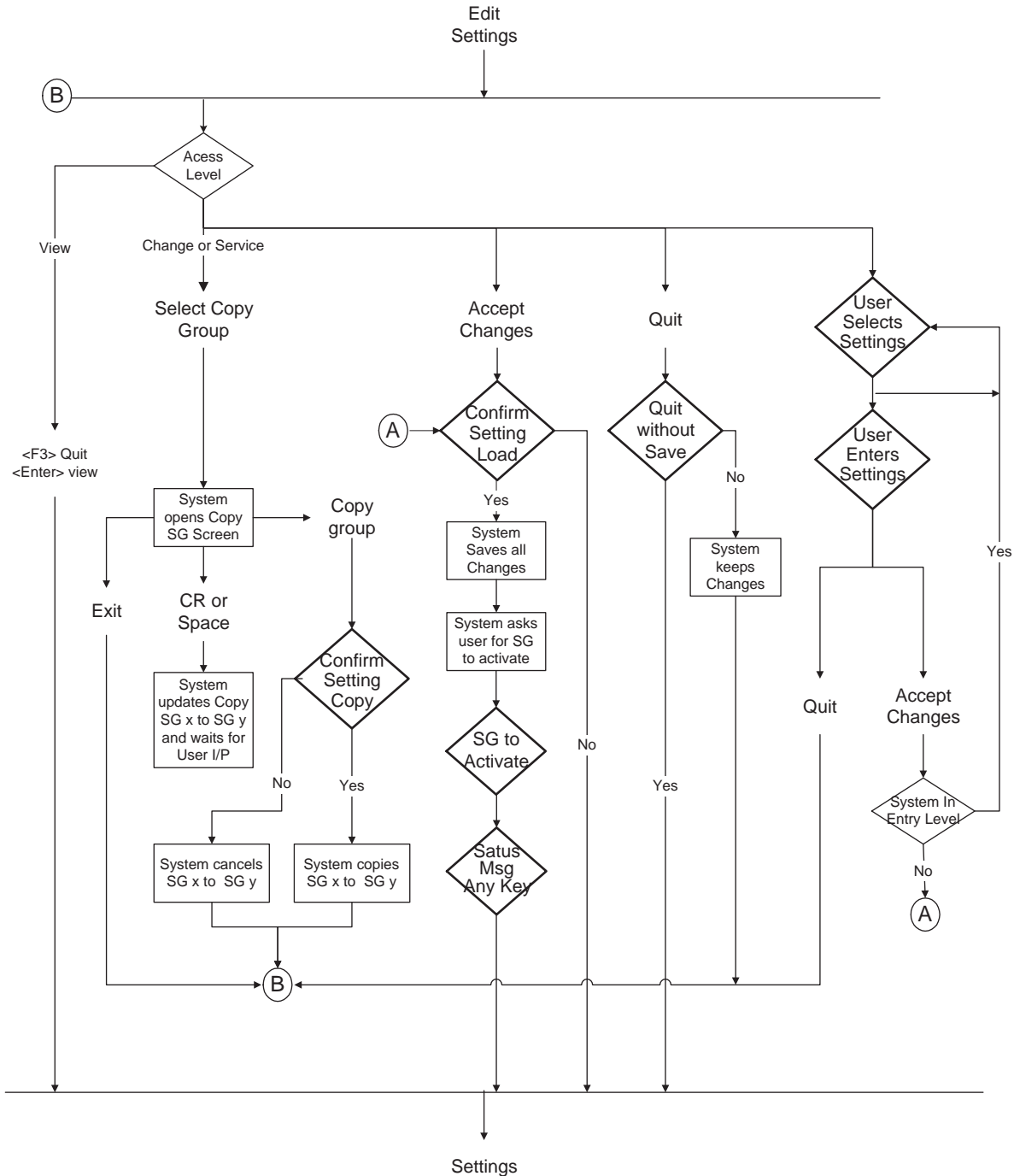

The following is the flow of events that can occur in the Load Settings Screen.

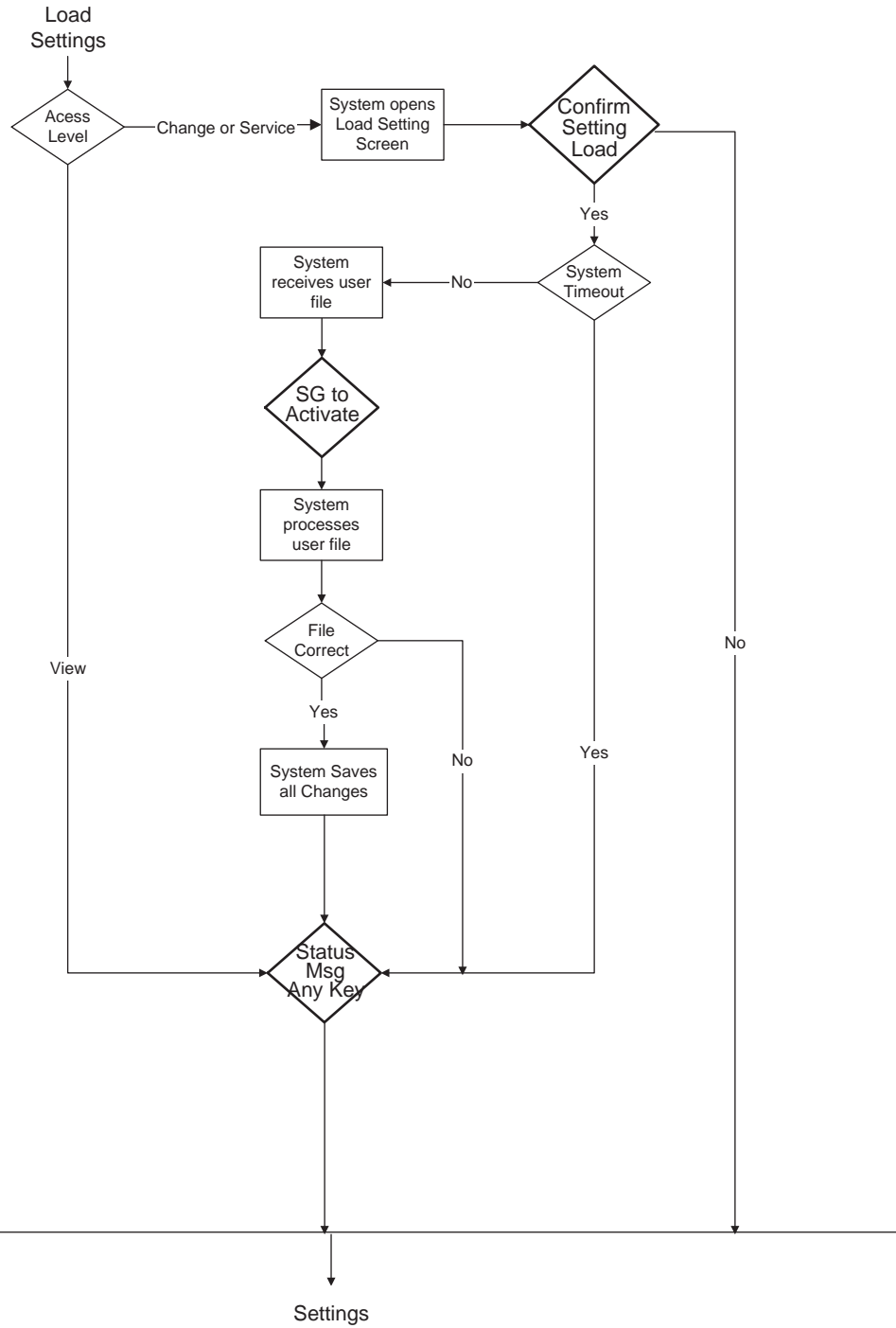

---

### Manual Settings Change

Relay configuration changes during a user-initiated manual setting; the change does not disrupt the relay protection functions. The relay logs an acceptance of the change request and puts the new setting file in service. When the new setting file is queued the relay loads the new setting configuration for protection functions to the protection processor. The relay loads the new name definitions for indication and recording functions to the interface processor. When the relay has completed loading the ancillary settings for indication purposes to the interface processor, an event is logged to show completion of the request.

There is some lag time during the load request and the completion of the request where the interface processor associates ancillary functions with the previous setting file for approximately 5 seconds. The ancillary setting information includes channel or ProLogic and Group Logic statements names, front panel target light activation rules and record initiation rules.

The protection processor does not have any interruption in service.
---

### Automatic Settings Change

Relay configuration changes during a relay-initiated setting; change does not disrupt the relay protection functions. Since the relay setting file does not change, the interface processor uses the new setting group ancillary setting information at the same time as the protection processor switches to the new setting group. An event is logged to show when the new setting group is in service.

## Communication-Aided Scheme

The L-PRO Relay provides 4 communication aided tripping scheme options. Permissive over-reaching transfer trip (POTT), a combination of POTT with weak infeed (WI), directional comparison blocking (DCB) or permissive under-reaching transfer trip (PUTT) are available to be used with external telecommunications devices for enhanced tripping of the protected line. The combination of phase distance, ground distance and neutral overcurrent elements provide flexible setting options for the selected communication aided tripping scheme.

Logic for 2 communication receivers can be used for 3 terminal lines or if the telecommunications use 2 separate communication channels. You can set the communications receivers to use one of 9 external inputs or one of the 12 ProLogic statements. The same input cannot be shared between the 2 communication receivers.

The output matrix is used to configure the communications scheme send (permissive trip or block), and the communications scheme trip (local tripping) to any combination of the 14 available output contacts. The user-set dropout extension on output contacts is eliminated on any contact that is configured to operate for the communication scheme send signal; you can provide your own dropout time delay with timer setting TD3.

The communications aided tripping scheme options use the general distance and overcurrent protection functions of the L-PRO, along with directional overcurrent elements specifically included in the scheme. These elements use the memory polarization as described in the “Relay Method of Memory Polarization” on page 4-5 and the directional element as described in “Directional Element” on page 4-7.

### 50/51N - OC Carrier Trip and Block Logic

The carrier start logic is traditionally initiated by the Zone 2 distance elements, but the L-PRO provides 2 directional neutral overcurrent elements that can be used in addition to the Zone 2 distance elements. The device 51N time overcurrent element, and the 50N/67F instantaneous overcurrent if enabled can be configured to drive the carrier start logic. The 51N is configured in the 50N/51N screen, while the 50N/67F is configured in the scheme selector screen, both elements are forward directional elements.

The carrier block logic is traditionally initiated by the Zone 4 distance elements, but the L-PRO provides one directional neutral overcurrent element that can be used in addition to the Zone 4 distance elements. The device 50N/67R, if enabled, can be configured to drive the carrier block logic. The 50N/67R is configured in the scheme selector screen and is a reverse directional element.

The scheme selector can also be configured to enable the 50N/67F and 50N/67R directional overcurrent elements as inputs to ProLogic statements. The 50N/67F element can be set to either forward directional or non-directional when you select the action, “ProLogic Only”.

If the pickup delay setting ( $T_p$ ) < 9ms, 9ms will be used for the delay. Otherwise  $T_p$  will be used for the delay. This change is always applied regardless of the direction setting (Non-dir, FWD, REV) and the 3I0 pickup level.



Note: If the directional element can not determine a valid direction, the direction is set to "forward", the 50N/67F may operate, and the 50N/67R element is blocked. See "Directional Element" on page 4-7.

**Basic Logic**

The basic selection does not provide any communication-aided logic for local or remote protections.

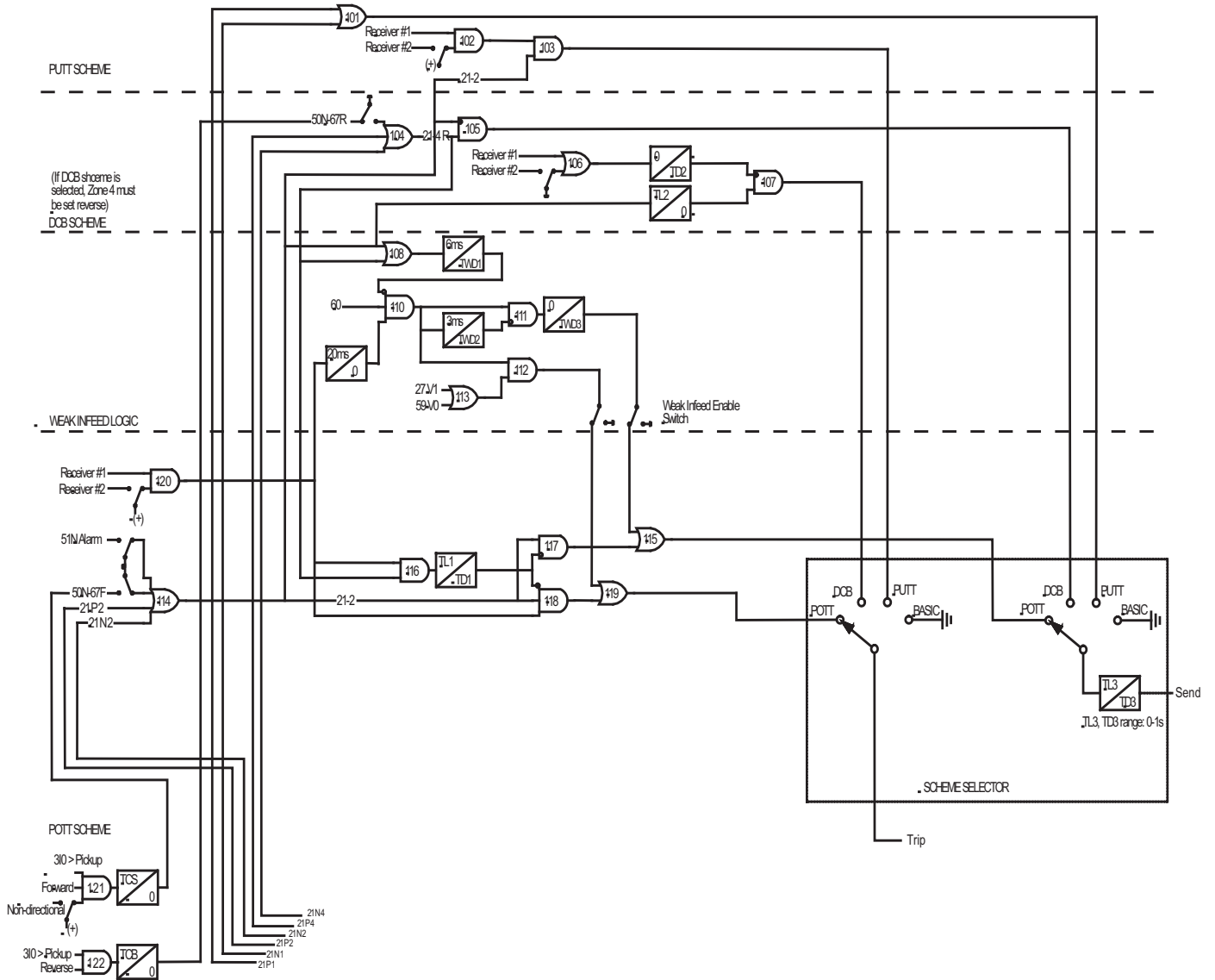

Figure 4.23: Communication-aided Scheme

## POTT Logic

The POTT logic is used for tripping schemes where the local end over-reaches the remote end for forward fault conditions, for details see Figure 4.23: Communication-aided Scheme on page 4-41. The local end sends a permissive trip signal to the remote end when one of the forward directional elements operates. The scheme send signal (permissive transfer trip send) is time delayed by timer setting TL3; the local end is required to sense a forward fault for durations greater than TL3. The local end does not produce a scheme trip output unless the remote has detected a forward directional fault and sends the similar permissive trip signal to the local end. The local end senses a permissive trip receive signal and the scheme trip closes the output contacts and removes the fault contribution from the local end. The remote end acts in a similar fashion and the fault contribution is removed from the remote end.

Current reversal logic guards against incorrect permissive tripping for installations with parallel lines where one end of the un-faulted line is contributing fault current and the other end of the un-faulted line is over-reaching and sending a permissive trip signal. The local reverse directional elements are used with the permissive receive signal from the remote end to form the blocking logic. The blocking logic is time delayed by timer setting TL1; the local end is required to sense reverse faults while receiving the remote permissive trip for durations greater than TL1. The blocking logic continues to block the scheme send and scheme trip signals when the reverse fault detection or permissive trip receive signals go low. Timer setting TD1 determines the current reversal block extension time.

For line terminals with a weak source, fault conditions could occur on the protected line where no elements operate at the weak source. Weak infeed (WI) logic enables the relay to protect lines where one end of the line has no source or has a very weak source. The WI scheme can only be enabled if you have selected the POTT scheme otherwise it is disabled. If enabled, the WI feature enhances the POTT tripping logic.

WI enables the POTT scheme to quickly isolate line faults where one end of the line has a high source of impedance.

During fault conditions where no weak source elements pick up the WI logic echoes back the permissive transfer trip signal received by the weak source. If a permissive transfer trip is received from the remote line end, AND 110, AND 111 and OR 115 echo a POTT signal back to the remote end. The permissive transfer trip signal is required to last for durations greater than 20ms. A 3ms time delay pickup and time delay dropout timer TWD2 determine the amount of time between permissive transfer trip receive signals that the scheme echoes back. If the permissive transfer trip receive signal is constantly high the WI logic only echoes back for a time equal to TWD3 plus 3ms. If the PT signal being received resets then starts up again, after timer setting TWD2, a new permissive transfer trip signal echoes back.

The WI logic blocks when forward or reverse faults are detected, the logic is also blocked for a loss of potential condition. During a reverse or a forward fault condition, the Zone 2, Zone 4, 51N, or 50N/67 elements could pick up. If any of these functions pick up, they block the WI scheme by putting a high input into inverted input of AND 110. The blocking condition is required last for durations greater than 6 ms. The blocking logic continues to block the scheme

send and scheme trip signals when the fault detection or loss of potential signals go low. Timer setting TWD1 determines the block extension time. TWD1 should be set to coordinate with the communication-reset time of the PT signal. It should be set greater than the time it takes for the remote end's Zone 2 to reset and for the PT channel to reset.

Timer setting TWD2 should be set to a time that prevents chattering of the communications channel. If TWD2 is allowed to reset before the remote end (strong source) clears the fault and stops sending the permissive transfer trip signal the WI echoes back another block of permissive transfer trip send.

The WI logic is also used to provide local tripping if both ends of the line are to be isolated. The line voltages provide supervision with a positive sequence under-voltage element (27V1) and a zero sequence over-voltage element (59V0). If a permissive transfer trip is received from the remote line end, AND 110, AND 112, OR 113 and OR 119 provide a local tripping signal.

## DCB Logic

The DCB logic is used for tripping schemes where the local end over-reaches the remote end for forward fault conditions, for details see Figure 4.23: Communication-aided Scheme on page 4-41. Typically DCB is used when the communications link may be disrupted during fault conditions, for example power line carrier. The local end sends a block trip signal to the remote end when one of the enabled reverse directional elements operates. The scheme send signal (block trip send) is time delayed by timer setting TL3, the local end is required to sense a reverse fault for durations greater than TL3. If one of the forward directional elements operates the blocking logic does not operate. For forward directional fault conditions the DCB logic is time delayed by timer setting TL2. The forward fault condition has to last for durations greater than TL2. The local end does not produce a scheme trip output if the remote has detected a reverse directional fault and sends the similar block trip signal to the local end. The local end senses a block trip receive signal and the scheme trip logic is disabled with no intentional delay. Current reversal logic guards against incorrect local tripping for installations with parallel lines where one end of the un-faulted line is contributing fault current and the other end of the un-faulted line is reverse-reaching and sending a block trip signal. The local forward directional elements are supervised by the block receive signal from the remote end to form the blocking logic. The blocking logic reset is time delayed by timer setting TD2; the local end is required to receive the remote block trip for durations greater than 0 ms. The blocking logic continues to block the scheme trip signals when the block trip receive signal goes low. Typically the block reset timer TD2 is set longer than the forward directional elements reset time.

**PUTT Logic**

The PUTT logic is used for tripping schemes where the local end under-reach the remote end for close in forward fault conditions, for details see Figure 4.23: Communication-aided Scheme on page 4-41. The local end sends a permissive trip signal to the remote end when one of the forward directional elements operates (Zone 1 distance elements). The scheme send signal (permissive transfer trip send) is time delayed by timer setting TL3, the local end is required to sense a forward fault for durations greater than TL3. The remote end does not produce a scheme trip output unless a forward directional fault is detected and the local end has sent the permissive trip signal. The remote end senses a permissive trip receive signal and the scheme trip closes the output contacts and removes the fault contribution from the remote end. The remote end can act quicker for fault conditions where the Zone 2 faults would be time delayed unless the close in fault condition was not transferred by the scheme send.

---

## Recording Functions

The relay has high speed fault recording and logging functions to allow you to analyze faults and to review the operation of the overall protection scheme. Slow speed swing recording can be used to analyze system stability. If the relay has reached its recording capacity, new records overwrite the oldest records.

### Fault Recording

The relay provides DFR-quality fault recording, capturing input signal waveforms and external input states at a rate of 96 samples per cycle. Each record also contains the timing of the internal logic produced by the relay (e.g. Device 51 trip). Obtain this information by uploading the records from the relay via the terminal mode file transfer process and view them with RecordBase View software.

The quantities recorded are:

- 18 analog channels (6 voltages and 12 currents) @ 96 samples/cycle up to the 25th harmonic
- External inputs @ 1 ms resolution
- Protection element output signals @ 8 samples/cycle
- ProLogic signals @ 8 samples/cycle
- Active setting group

Parameters that are user-selectable with respect to recording transients:

- Record length (0.2 to 2.0 seconds => 12 to 120 cycles @ 60 Hz Base) with automatic extension to capture successive triggers
- Recorder triggering by any internal logic or external input signal

### Swing Recording

The L-PRO records dynamic system responses allowing you to analyze system stability and to provide a larger context for fault analysis. Swing records contain positive sequence phasor measurements and system frequency calculated at a rate of 1 phasor per cycle. Swing records can extend to 3 minutes in duration.

The quantities recorded are:

- Positive sequence impedance (magnitude)
- Positive sequence voltage (magnitude)
- Positive sequence current (magnitude)
- 3-Phase Vars (reactive power)
- 3-Phase Watts (real power)

### Event Recording

The event recording provides permanent storage for the event log. You can create an event record automatically or manually. When the event auto save is enabled, an event record is created approximately every 230 events.

You can initiate an event manually through the terminal user interface. The command Event Recording is available under the *Records>Event Recording* menu.

## Record Initiation

Recording can be initiated automatically by the relay when a fault or abnormal condition is detected. You can set the relay to initiate a fault record on activation of any of its trip or alarm functions or on assertion of any external digital inputs.

The assignment of fault record initiation to the various relay functions is done through the relay's Output Matrix settings.

A recording can also be initiated manually through the terminal user interface. The commands *Fault Recording*, *Swing Recording* and *Event Recording* are available under the *Records* menu.

A swing record can take a couple of minutes to produce due to the long post-trigger time.

## Record Duration and Extension

The length of each record is determined by the Record Length setting. Transient record lengths can be set between 0.2 and 2.0 seconds; swing record lengths can be set between 30 and 120 seconds. Pre-trigger times are fixed at 10 cycles for transient records and 30 seconds for swing records and are included as part of the normal record length.

The L-PRO automatically extends a record as required to capture consecutive triggers that are close together. If a trigger occurs while a recording is in progress, the record is stretched to include the full post-trigger time of subsequent triggers, up to a maximum length—2.0 seconds for transient records; 180 seconds for swing records. If a trigger occurs before the end of a record caused by a previous trigger, but too late to allow sufficient post-trigger time in a maximum extended record, a new overlapping record is created.

The normal record lengths settings are accessible under the *Recording* heading of the relay settings, and can be set from either the terminal user interface or the *Offliner* Settings software.

## Record Storage

The L-PRO compresses records on the fly, achieving a typical lossless compression rate of 4:1. As a result, the L-PRO can store up to 30 seconds of transient recordings and up to 24 minutes of swing recordings in non-volatile storage. If the storage is full, new records automatically overwrite the oldest, ensuring that the recording function is always available.

---

## Logging Functions

### Event Log

The relay maintains a log of events in a 250 entry circular log. Each entry contains the time of the event plus an event description.

Logged events include trips, alarms, external input assertions plus internal events such as setting changes. Phase information is included in event messages where appropriate. For example, the event log entry for a device trip might be:

2000 Nov 21, 15:34:19.832: 51 on ABC Trip

The event log can be viewed in 2 ways:

Front Panel	The front panel display shows events in abbreviated form (Trip and Alarm events only).
Terminal User Interface	The full event log is available through the Event Log menu of the terminal user interface.

This display is a snapshot of the event list which must be manually refreshed to display new events that occur while the display is up.

There is a list of Event Messages, for details see “Event Messages” in Appendix D.





# 5 Offliner Settings Software

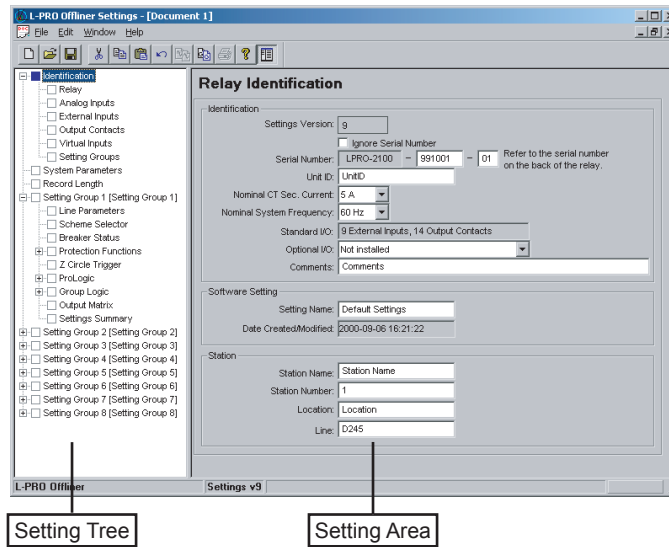

Figure 5.1: Opening Screen

## Introduction

Use the *Offliner* Settings software to create relay settings on a PC. *Offliner* Settings provides an easy way to view and manipulate settings.

## PC System Requirements

### Hardware

The minimum hardware requirements are:

- 1 GHz processor
- 2 GB RAM
- 20 GB available hard disk space
- USB port
- Serial communication port

### Operating System

The following software must be installed and functional prior to installing the applications:

- Microsoft Windows XP Professional Service Pack 3 or
- Microsoft Windows 7 Professional Service Pack 1 32-bit or 64-bit

## Installing PC Software

Insert the CD-ROM in your drive. The CD-ROM should open automatically. If the CD-ROM does not open automatically, go to Windows Explorer and find the CD-ROM (usually on D drive). Open the L-PRO.exe file to launch the CD-ROM.

To install the software on your computer, click the desired item on the screen. The installation program launches automatically. Installation may take a few minutes to start.

To view the L-PRO User Manual you must have Adobe Acrobat on your computer. If you need a copy, download a copy by clicking on Download Adobe Acrobat.

### Anti-virus/Anti-spyware Software

If an anti-virus/anti-spyware software on your local system identifies any of the ERLPhase applications as a “potential threat”, it will be necessary to configure your anti-virus/anti-software to classify it as “safe” for its proper operation. Please consult the appropriate anti-virus/anti-spyware software documentation to determine the relevant procedure.

## Offliner Features

The *Offliner* software includes the following menu and system tool bar.

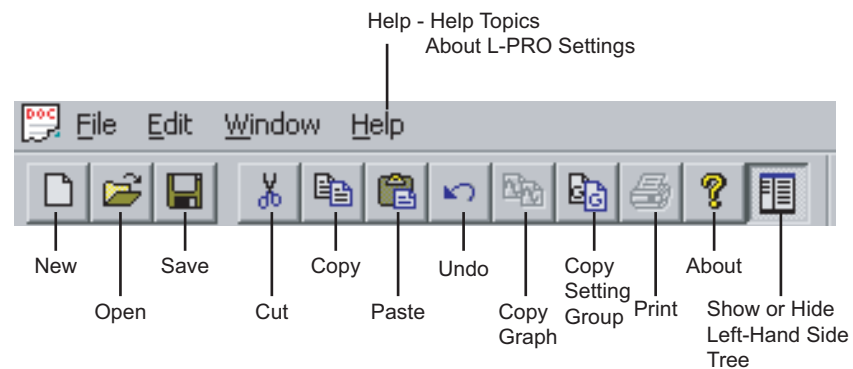

Figure 5.2: Top Tool Bar

Tool Bar	
<b>Windows Menu</b>	
Icon	Restore, minimize, close.
File	New, open, close, save, save as, print setup.
Edit	Undo, cut, copy, paste.
Window	Cascade, tile, arrange icons.
Help	Help Topics, About L-PRO Settings.

<b>Settings Program Icons</b>	
New	Open new default settings file.
Open	Open any valid settings file.
Save	Save current settings file.
Cut	Edit function.
Copy	Edit function.
Paste	Edit function.
Undo	Edit function.
Copy Graph	Copy to clipboard.
Copy Setting Group	Copy from Setting Group X to Setting Group Y.
Print	Print from Output Matrix or any graph.
About	Version number.
Show or Hide Left-Hand Side Tree	Show or Hide Left-Hand Side Tree

## **Graphing Protection Functions**

### **Grid On/Grid Off**

The graph can be viewed with the grid on or off by clicking the Grid On or Grid Off button. A right-click on the trace of the curve gives you the x and y coordinates.

### **Print Graph**

To print a particular graph, click the Print Graph button.

### **Zoom on Graphs**

Graphs can be zoomed to bring portions of the traces into clearer display. Left-click on any graph and drag to form a small box around the graph area. When you release the mouse, the trace assumes a new zoom position determined by the area of the zoom coordinates.

To undo the zoom on the graph, click the Refresh button.

## Handling Backward Compatibility

*Offliner* Settings displays the version number in the second pane on the bottom status bar. The settings version is a whole number (v1, v2, v3, v4, etc.).

The *Offliner* Settings is backward compatible; open and edit older settings files and convert older settings files to a newer version. *Offliner* settings handles forward conversion only—it converts an older setting file to a newer setting file.

### Converting a Settings File

- 1 Open the setting file you wish to convert.
- 2 In the *File* menu, select *Convert to...* and then select the *version x* (where *x* is the newer version). A dialogue box pops up prompting *Offliner* for a new file name. Use either the same file name or enter a new file name. The conversion process inserts default values for any newly added devices in the new setting file. When the conversion is complete, *Offliner* Settings displays the new file.

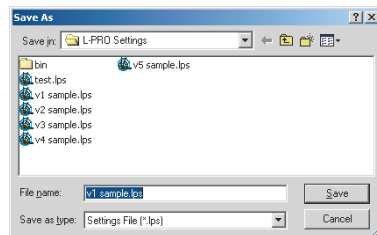

Figure 5.3: Converting Setting Files

### Sending a New Setting File to the Relay

- 1 Make sure the settings version and the serial number of the relay in the setting file match. The relay will reject the setting file if either the serial number or the settings version do not match.

A “serial number discrepancy” message may appear. This is to ensure that you are aware of the exact relay in which settings are to be loaded. If this happens, check the relay serial number using the terminal mode ID menu item. Type this serial number into the L-PRO Serial No. box in the Identification tab display area of *Offliner* Settings. Alternately you may check the Ignore Serial Number check box to bypass serial number supervision.

- 2 Check the serial number and the settings version of the relay, for details see “ID” on page 3-10. The Device Serial Number and Required Settings Version on the Identification screen indicate the serial number and the settings version of the relay.

### Creating a Setting File from an Older Version

- 1 *Offliner* Settings displays a default setting file on start up showing the settings version in the bottom status bar. As an example L-PRO *Offliner* is shipped with a set of default sample files of older settings versions. These sample files are “v1 sample.lps”, “v2 sample.lps”, “v3 sample.lps”, etc. Each sample file contains default values of an older settings version. For a

new installation these sample files are placed in the default directory C:\Program Files\ERLPhase\L-PRO Offliner Settings, or you can choose the path during the *Offliner* software installation. If an older version of L-PRO *Offliner* was previously installed on your PC, then the default directory may be C:\Program Files\APT\L-PRO Offliner Settings.

- 2 Open a sample file of the desired version. Use *File/Save As* to save the sample file to a new file name. Then edit the setting file and the serial number, save it and load it into the relay.

## RecordBase View Software

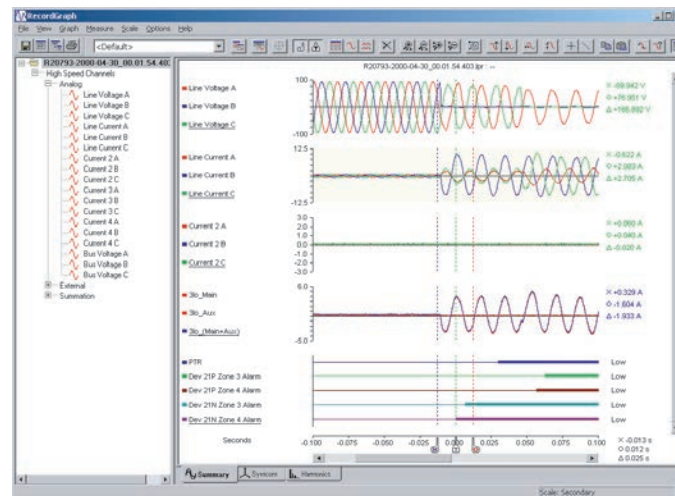

Figure 5.4: RecordGraph

Use RecordBase View and RecordGraph to analyze the records from a relay.

- 1 Set the receive directory on your terminal program to point to a convenient directory on your PC's hard disk or network. For example with HyperTerminal, select *Transfer>Receive File* to set the receive directory.
- 2 Select one or more records on the relay using the *List* function in the Terminal Mode's *Records* menu.
- 3 Initiate transfer of the selected records by selecting *R* on the keyboard.
- 4 Start the RecordBase View program and use the *File>Open* menu command to open the downloaded record files located in the receive directory specified in step 1.

For further instructions refer to the RecordBase View Manual at the back of the printed version of this manual.

# Main Branches from the Tree View

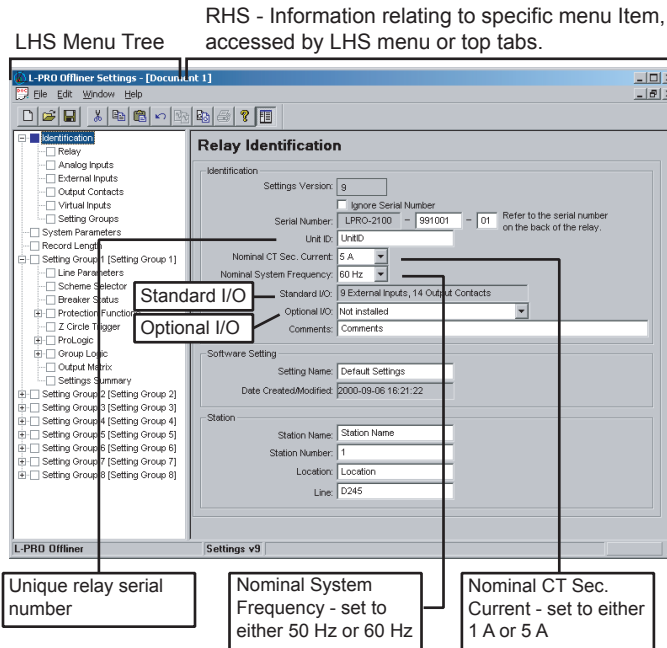

Figure 5.5: Relay Identification

## Identification

The first screen presents all the menu items in the left menu tree. Access the menu items by clicking the tabs at the top of the screen or the item on the left menu tree.

Identification	
Settings Version	Indicates the settings version number, fixed.
Ignore Serial Number	Bypass serial number check, if enabled.
Serial Number	Available at back of each relay.
Relay ID	User-defined up to 20 characters.
Nominal CT Format	5 A or 1 A
Nominal System Frequency	60 Hz or 50 Hz
Comments	User-defined up to 20 characters.
Setting Software	
Setting Name	User-defined up to 20 characters.
Date Created/Modified	Indicates the last time settings were entered.
Station	
Station Name	User-defined up to 20 characters.
Station Number	User-defined up to 20 characters.
Location	User-defined up to 20 characters.

Equipment Protected	User-defined up to 20 characters.
---------------------	-----------------------------------

### Important Note

Nominal CT Secondary Current can be set to either 1 A or 5 A.  
 Nominal System Frequency can be set to either 50 Hz or 60 Hz.  
 Ensure setting selection matches that of target L-PRO.

The serial number of the relay must match the one in the setting file, or the setting will be rejected by the relay. This feature ensures that the correct setting file is applied to the right relay.

In Settings Version 7 or greater you can choose to ignore the serial number enforcement in the identification screen. The relay only checks for proper relay type and setting version if the ignore serial number has been chosen, requires relay firmware version 3.0 or greater.

## Analog Inputs

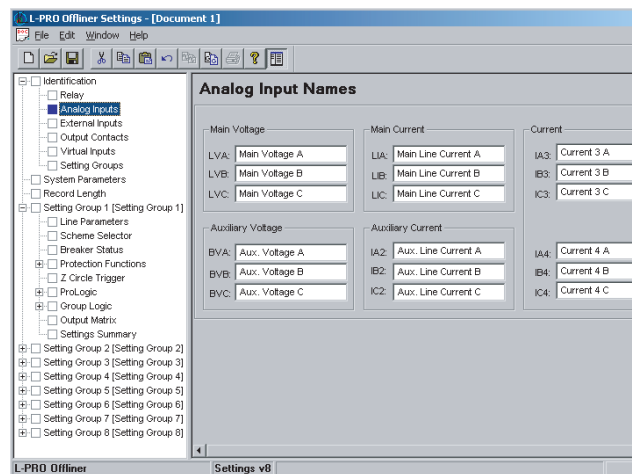

Figure 5.6: Analog Inputs

Analog Input Names screen identifies all the ac voltage and current inputs to the relay. These names appear in any fault disturbance records the relay produces.

Analog Inputs	
Main Voltage	LVA, LVB, LVC
Main Current	LA1, LB1, LC1
Aux. Voltage	BVA, BVB, BVC
Aux. Current	IA2, IB2, IC2
Current	IA3, IB3, IC3, IA4, IB4, IC4

### External Inputs

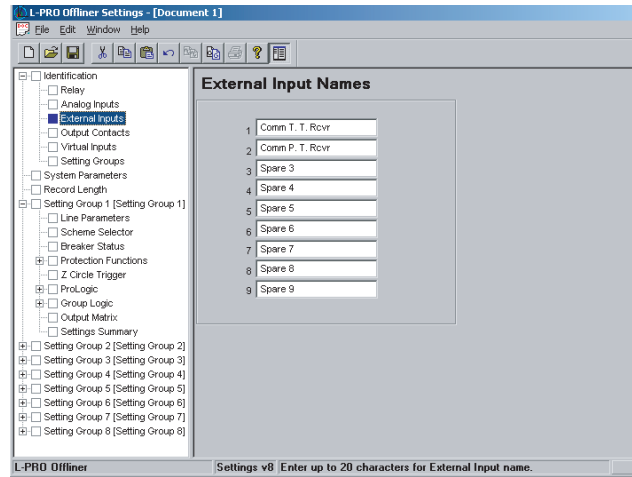

Figure 5.7: External Inputs

External Input Names screen allows you to define meaningful names for 9 external digital inputs.

T.T. Refers to Transfer Trip and P.T. Permissive Trip.

External Input Names	
1 to 9	User-defined



## Output Contacts

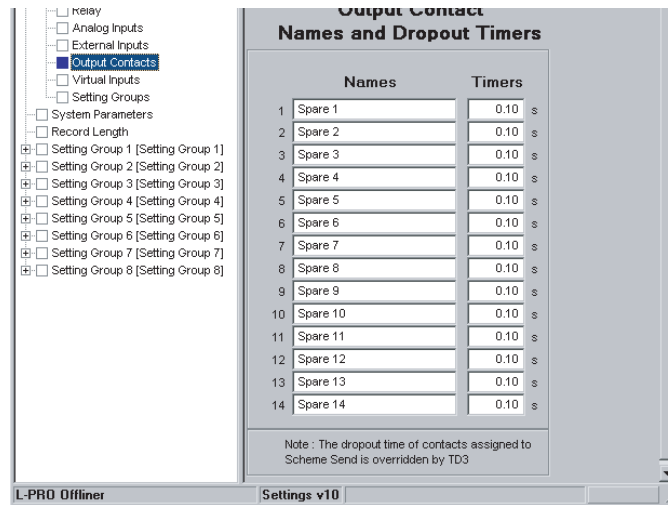

Figure 5.8: Output Contacts

The Output Contacts are also identified during the setting procedure using meaningful names. The dropout delay time settings are made here.

Output Contact Names	
Outputs 1 to 14/21	User-defined
Dropout Timer	0.00 to 1.00 s

## Virtual Inputs

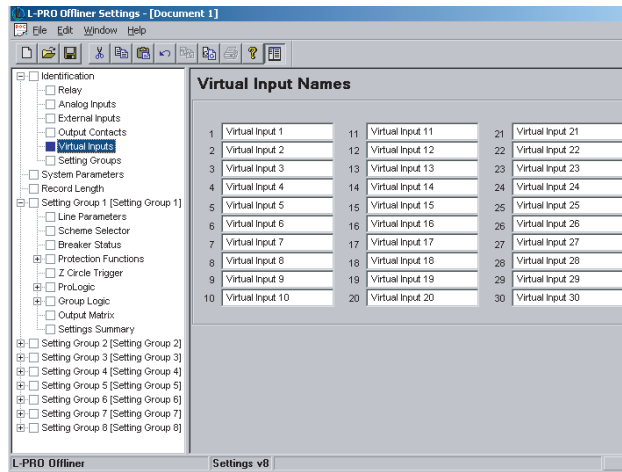

Figure 5.9: Virtual Inputs

Virtual Inputs	
Virtual Inputs 1 to 30	User-defined

The relay can control its internal functions and connected devices both locally and remotely. Thirty general purpose logic points are accessible via DNP3 and the terminal UI. The 30 virtual inputs are individually controlled and include a set, reset and pulse function. The latch state is retained during setting changes and relay power down conditions. The 30 virtual inputs conform to DNP3 standards. Use the DNP3 functions such as SBO (select before operate), Direct Operate, or Direct Operate with no acknowledge to control virtual inputs.

Use virtual inputs to:

- control circuit breakers
- enable or disable reclosing
- enable or disable under-frequency load shedding
- change setting groups
- provide interlocking between local/remote supervisory control

## Setting Groups

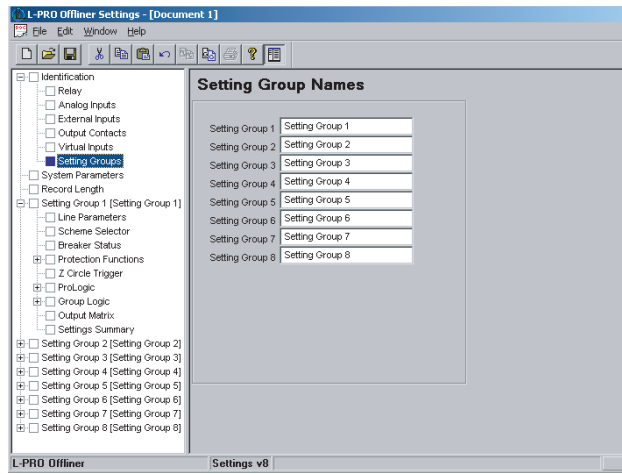

Figure 5.10: Setting Groups

Setting Groups	
Setting Groups 1 to 8	User-defined

## System Parameters

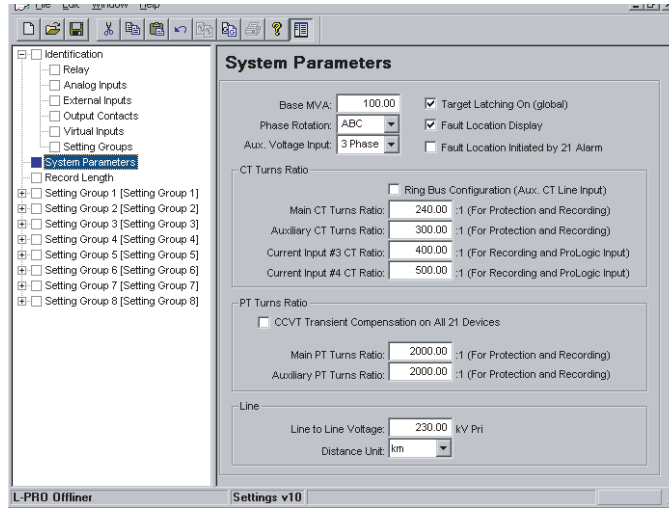

Figure 5.11: System Parameters

System Parameters	
System Parameters	
Base MVA	1.00 to 1000.00 MVA (primary)
Target Latching On (global)	Enable/disable
Phase Rotation	ABC or ACB
Aux Voltage Input	3-phase/1-phase
Fault Location Initiated by 21 Alarm	Enable/disable
CT Turns Ratio	
Ring Bus Configuration (Aux. CT Line Input)	Enable/disable
Main CT Turns Ratio	1.00 to 1000.00 (For protection and recording)
Aux. CT Line Input	Enable/disable
Auxiliary CT Turns Ratio	1.00 to 10000.00 (For protection and recording)
Current Input #3 CT Ratio	1.00 to 10000.00 (For recording and ProLogic)
Current Input #4 CT Ratio	1.00 to 10000.00 (For recording and ProLogic)
PT Turns Ratio	
Main PT Turns Ratio	1.00 to 20000.00 (For Protection and Recording)
Auxiliary PT Turns Ratio	1.00 to 20000.00 (For protection and recording)
Line	
Line to Line Voltage	1.00 to 1000.00 kV (Primary)
Distance Units	km or miles

## Target Latching On

This option specifies whether the front Target LED is latched or not. Target Latching On means that the target LED remains on after a trip until it is reset through the front by human machine interface (HMI). If the Target Latching is set off the target light comes on during a relay trip and will reset. All targets are stored in the relay log—250 event logs are stored.

## Base MVA

The base MVA is used for recording purposes.

## CT Turns Ratio and PT Turns Ratio

The CT and PT ratios are specified for the monitoring of analog inputs. All CT and PT ratios are specified with a ratio relative to one. The line protection uses the main current and the main voltage to operate. When 2 sets of CTs (main and auxiliary) are used as line current input (e.g. ring bus application), you must enable ring bus configuration to configure the relay. If enabled, the currents from the 2 sets of CTs are added to the relay to form the line current. For cases where voltage for line protection is obtained from bus PTs, the bus PTs are connected to the main voltage inputs.

## Auxiliary Voltage Input

If a single-phase source is used, it must be connected to the corresponding phase designation on the relay input. example: If only a B phase bus PT is available, it should be connected to the relay input B phase terminals. All unused single-phase inputs must be grounded for proper operation.

## SCADA Communication

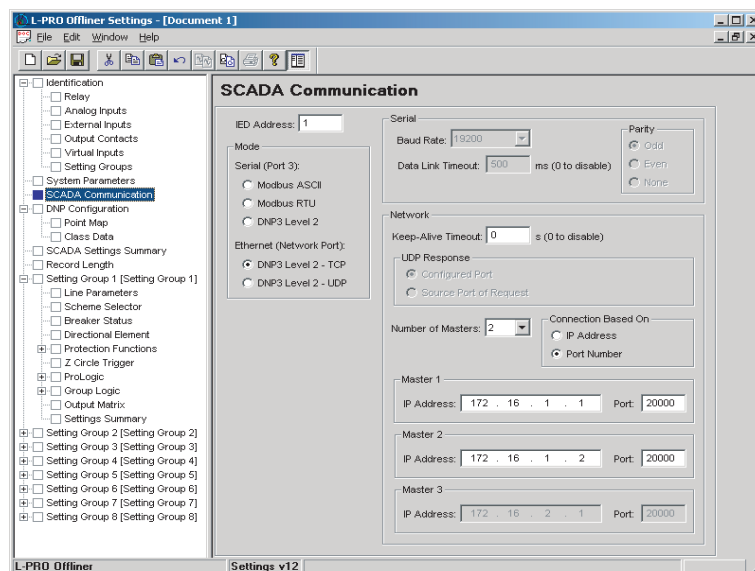

Figure 5.12: SCADA Communication

The L-PRO relay has configurable SCADA communication parameters for both Serial (Port 3) and Ethernet (TCP and UDP). For DNP3 Level 2 (TCP) up to three independent Masters are supported.

## DNP Configuration - Point Map

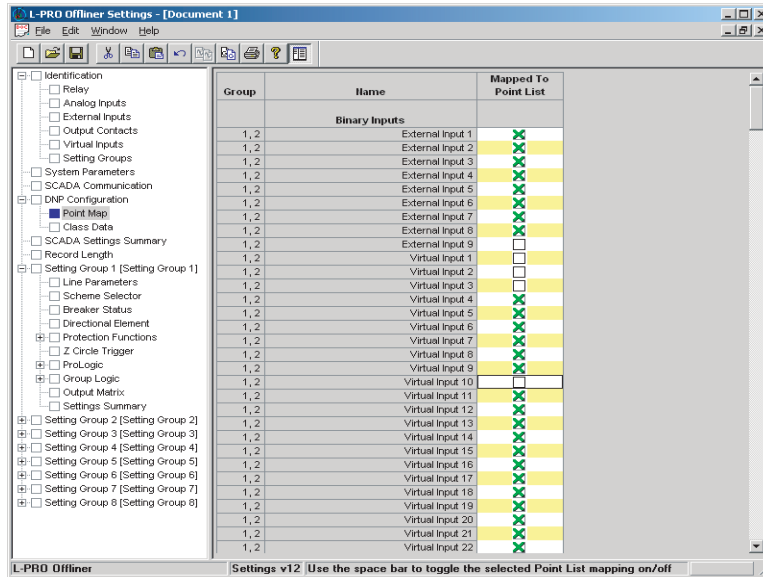

Figure 5.13: Point Map

The L-PRO relay has configurable DNP point mapping. On the Point Map screen, any of the configurable points may be added or removed from the Point List by clicking (or using the cursor keys and space bar on the keyboard) on the associated checkbox. A green 'X' denotes that the item will be mapped to the Point List.

The list contains separate sections for Binary Inputs, Binary Outputs, and Analog Inputs. The list is scrollable by using the scroll control on the right hand side.

## DNP Configuration - Class Data

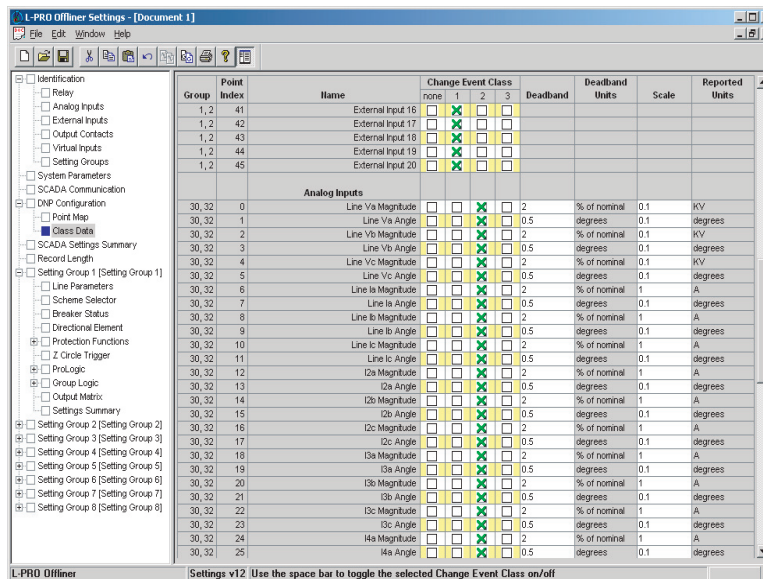

Figure 5.14: Class Data

Class data for each DNP point can be assigned on the Class Data screen. Only Points which were mapped in the Point Map screen will appear here. Sections for Binary Inputs and Analog Inputs appear here; Binary Outputs cannot be assigned a Class. The list is scrollable by using the scroll control on the right hand side.

In addition to assigning a Change Event Class to each mapped point, most Analog Inputs can also be assigned a Deadband and Scaling factor.

## SCADA Settings Summary

The screenshot shows the 'L-PRO SCADA Summary' window. The table below represents the data shown in the 'Binary Inputs' section of the screenshot.

Name	Value-Group	Point Index	Change Event Class	Deadband	Deadband Units	Scale	Reported Units
<b>SCADA Communication</b>							
ID Address	1						
Mode	Ethernet (Network Port) DNP3 Level 2 - TCP						
Baud Rate	19200						
Parity	Odd						
Data Link Timeout	500						
Keep-Alive Timeout	0						
LDP Response	Source Port of Request						
Number of Masters	1						
Connection Based On	Port Number						
Master 1 IP Address	172.16.1.1						
Master 1 Port	20000						
Master 2 IP Address	172.16.1.2						
Master 2 Port	20000						
Master 3 IP Address	172.16.2.1						
Master 3 Port	20000						
<b>Binary Inputs</b>							
External Input 1	1, 2	0	none				
External Input 2	1, 2	1	1				
External Input 3	1, 2	2	2				
External Input 4	1, 2	3	3				
External Input 5	1, 2	4	1				
External Input 6	1, 2	5	1				
External Input 7	1, 2	6	1				
External Input 8	1, 2	7	1				
Virtual Input 4	1, 2	8	1				

Figure 5.15: SCADA Settings Summary

This screen provides a summary of the current SCADA settings as set in the working setting file. This includes SCADA Communication parameters and (if the SCADA mode is set to DNP) Binary Input, Binary Output, and Analog Input information including Deadband and Scaling factors.

This SCADA Summary screen is scrollable and can be printed.

## Record Length

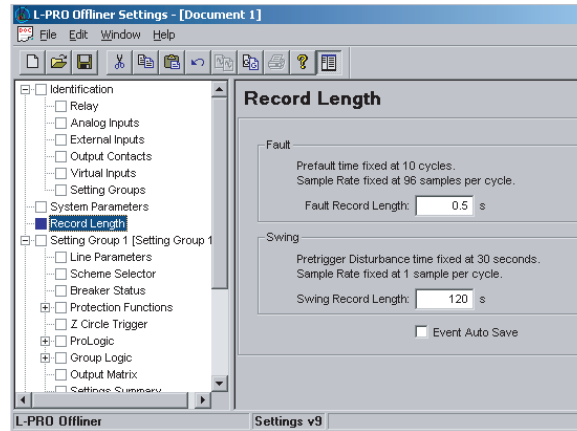

Figure 5.16: Record Length

Record Length	
Fault	
Fault Record Length	0.2 to 2.0 seconds
Swing	
Fault Record Length	6 to 120 seconds
Event Auto Save	Enable/disable

The L-PRO Relay has recording and logging functions to analyze faults and dynamic swing, and to review the operation of the overall protection scheme. This item identifies the amount of time that each fault record. Prefault is fixed at 0.16 second. There are 2 types of recording provided and the record length times available for each type of recording, transient or swing produce a separate record.



## Setting Groups

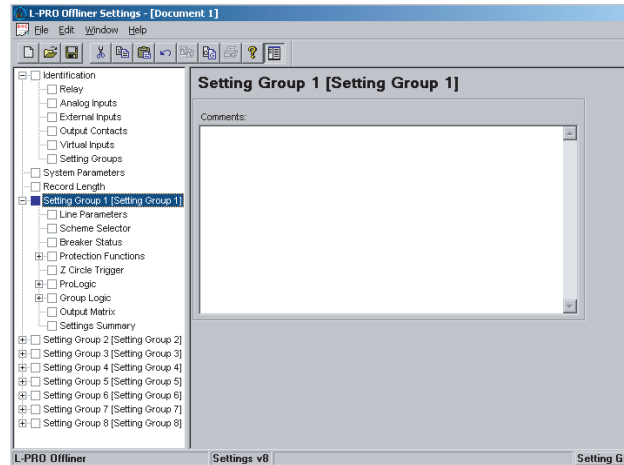

Figure 5.17: Setting Groups Comments

The relay has 8 setting groups (SG). You can change all relay setting parameters except the physical connections such as input or output parameters in each setting group. Use any one of the 16 available Group Logic Statements per setting group to perform Setting Group changes. The Group Logic statements are similar to the ProLogic statements with the following exceptions, the sole function is to activate one of the 8 setting groups and the processing is in a slower half second cycle. Group Logic inputs statements can be driven from ProLogic or any external input or virtual input or from previous Group Logic statements. Each Group Logic statement includes 5 inputs (with Boolean statements), one latch state and one pickup delay timer. View the active setting group (ASG) from the Terminal Mode, from the front panel or from a record stored by the relay (the active setting group is stored with the record).

## Line Parameters

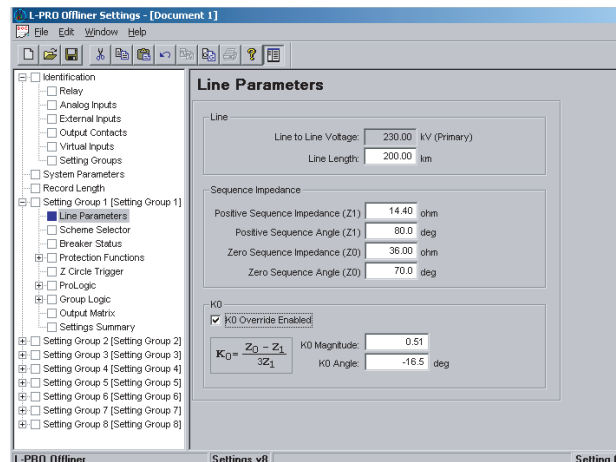

Figure 5.18: Line Parameters

<b>Line Parameters</b>	
Line	
Line to Line Voltage	kV (Primary)
Line Length	0.50 to 2000.00 km or 0.31 to 1250 miles
Sequence Impedance	
Positive Sequence Impedance (Z1)	0.05 to 66.00 ohms secondary (5 A) 0.25 to 330.00 ohms secondary (1 A)
Positive Sequence Angle (Z1)	45.0 to 89.0 degrees
Zero Sequence Impedance (Z0)	0.05 to 66.00 ohms secondary (5 A) 0.25 to 330.00 ohms secondary (1 A)
Zero Sequence Angle (Z0)	45.0 to 89.0 degrees
K0	
K0 Override	Enable/disable
K0 Magnitude	0.10 to 2.00
K0 Angle	-25.0 to 25.0 degrees

Line Parameter Settings permit a parameter entry related to the line voltage, CT ratio, PT ratio, line length, line secondary positive and zero sequence impedance.

The K0 factor used is a default factor based on the line parameters ( $K0 = [Z0 - Z1] / 3Z1$ ). You can specify by selecting *K0 Override Enable*.

## Scheme Selector

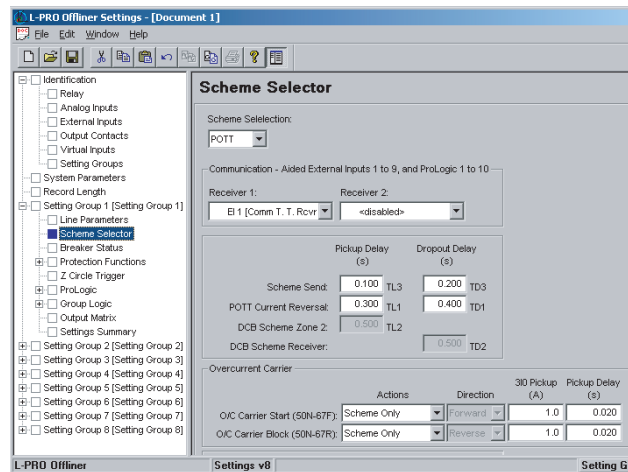

Figure 5.19: Scheme Selector

Scheme Selector	
Scheme Selection	POTT, PUTT, Blocking
Communication-Aided External Input 1 to 9 and ProLogic 1 to 10	
Receiver 1	External Input
Receiver 2	External Input
Scheme Send	User-defined, Pickup Delay (seconds), Dropout Delay (second)
POTT Current Reversal	User-defined, Pickup Delay (seconds), Dropout Delay (second)
DCB Scheme Zone 2	
DCB Scheme Receiver	
Overcurrent Carrier	
O/C Start (50N-67F)	Disabled, Scheme only, ProLogic only, Scheme and Pro-Logic
O/C Carrier Block (50N-67R)	Disabled, Scheme only, ProLogic only, Scheme and Pro-Logic

L-PRO supports a Basic (no communication), a Permissive Overreaching Transfer Tripping (POTT), a Permissive Under-reaching Transfer Tripping (PUTT) and a Directional Comparison Blocking Scheme (DCB).

### Directional Element

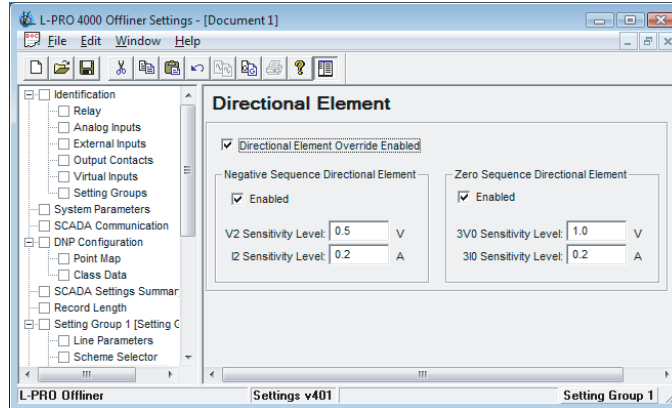

Figure 5.20: Breaker Status

Directional Element	
Negative Sequence Directional Element	V2 range 0.5 to 5 V I2 range 0.1 to 1 A
Zero Sequence Directional Element	3V0 range 1 to 10 V 3I0 range 0.2 to 2 A

### Protection Functions

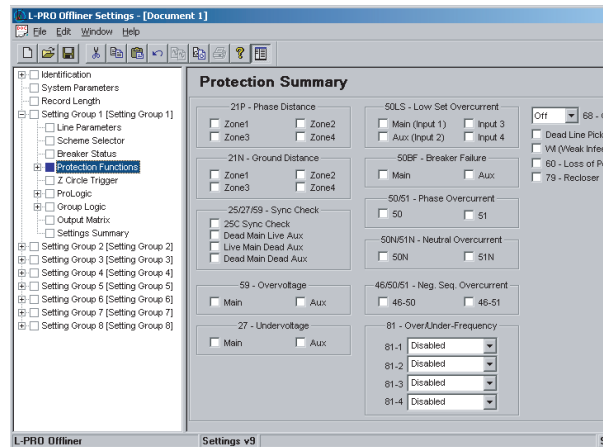

Figure 5.21: Protection Functions

For a detailed description see “Protection Functions and Specifications” on page 4-1

## ProLogic

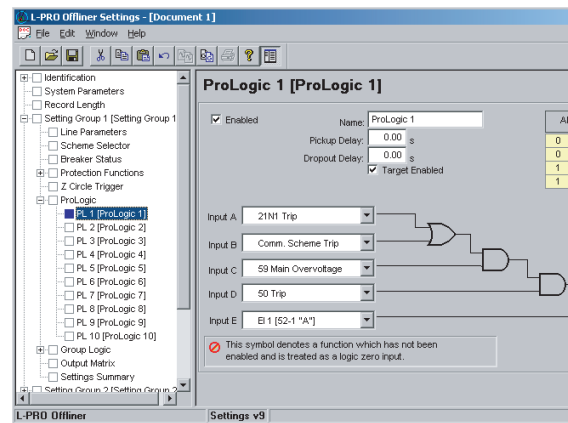

Figure 5.22: ProLogic

Apply ProLogic to multiple inputs to create an output based on qualified inputs. ProLogic enables up to 12 ProLogic control statements and programs those logics to output contacts. You can name the function being created and set a pickup and dropout delay. Start with input A by selecting any of the relay functions using the list for up to 5 possible inputs. Put these inputs into AND, NAND, OR, NOR, XOR, NXOR and LATCH logics by clicking on the gate. Invert the input by clicking on the input line.

The output of ProLogic 1 can be nested into ProLogic 2 and so forth. If described you can illuminate the front target LED on operation of this function by enabling this feature. The operation of the ProLogic statements are recorded in the events log. This logic shows on the view fault records.

## Group Logic

The 16 Group Logic statements reside in a slower processing thread within the relay protection algorithms. The processing cycle happens once every half second (0.5 s). When using ProLogic statements you must keep in mind that a latch or dropout timer should be used if the initiating condition does not last at least 0.5 seconds.

## Output Matrix

Figure 5.23: Output Matrix

The output contact matrix determines which function initiates which output relay. All output relays have an individual user-selectable stretch time, except those outputs identified as communication initiation outputs. They can have their time delay characteristics changed. Functions also initiate recording as required.

For a particular function to operate correctly, it must be enabled and must also have its logic output assigned to at least one output contact if it is involved in a tripping function.

Print the entire output matrix by right clicking on the output matrix then selecting the printer icon. This printout is produced on 2 pages.

## Settings Summary

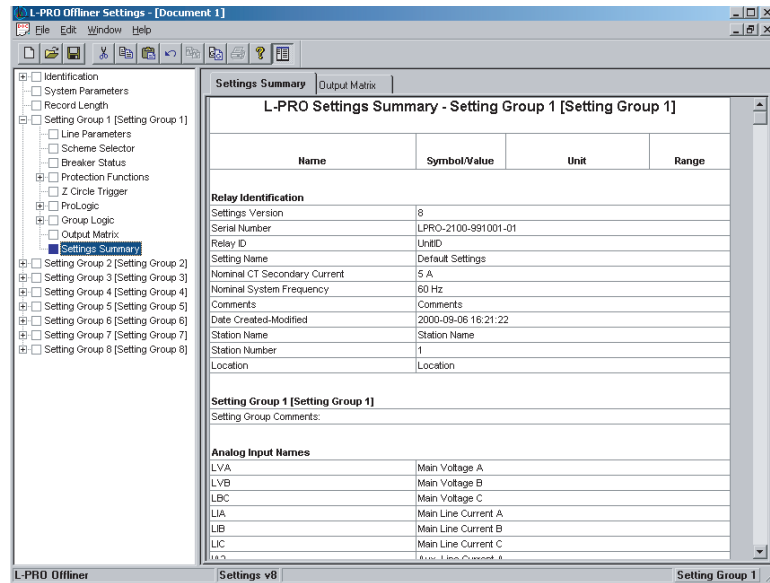

Figure 5.24: Settings Summary

Select *Settings Summary* to view and print the relay settings in text form, for details see “IED Settings and Ranges” in Appendix B.

## Settings From a Record

The settings on the relay at the time of a recording are included in every record and can be viewed through the RecordBase View analysis software. While viewing a recording in RecordBase View, select the *View Setting* button to display the settings. RecordBase View will automatically launch L-PRO *Offliner* to display the settings in summary form.

If the record contains Setting Groups, the *Offliner* displays all Setting Groups in the summary. Bold text in the tree view indicates an active Setting Group (the Setting Group used at the time the record was captured). The setting summary is read-only. To edit the setting file associated with the summary, you must use *File/Save As* to save the summary to a file. Then close the summary screen and open the setting file for editing.

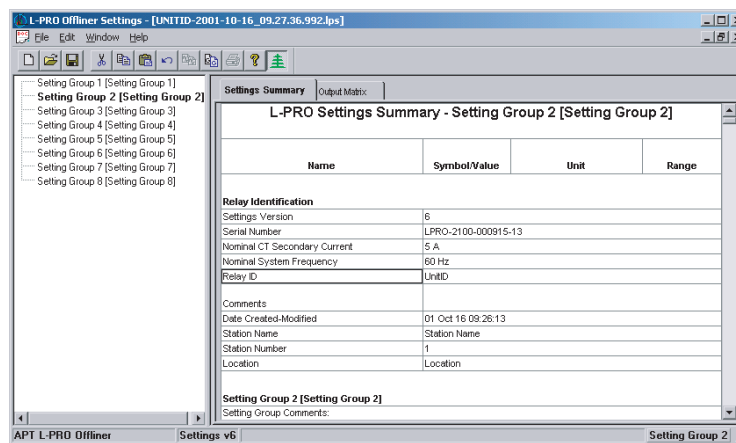

Figure 5.25: View Setting Summary in RecordBase View



---

# 6 Acceptance/Protection Function Test Guide

## Acceptance Testing

ERLPhase relays are fully tested before leaving the factory. A visual inspection of the relay and its packaging is recommended on receipt to ensure the relay was not damaged during shipping.

The electronics in the relay contain static sensitive devices and are not user-serviceable. If the front of the relay is opened for any reason exposing the electronics, take extreme care to ensure that you and the relay are solidly grounded.

Generally an analog metering check, as well as testing the I/O (External Inputs and Output Contacts) is sufficient to ensure the functionality of the relay. Further tests can be performed on delivery and acceptance of the purchaser's option according to the published relay specifications in "IED Settings and Ranges" in Appendix B.

The following acceptance test section is intended to be a guide for testing any and all protection elements in the relay. The most convenient time to perform these tests is on delivery prior to applying in-service settings. Once in-service settings are applied, ERLPhase recommends that you test enabled functions to ensure the designed application is fulfilled.

### Test Equipment Requirements

- 3 ac voltage sources (variable frequency capability)
- 3 ac current sources
- 1 ohmmeter
- 1 - 125 Vdc test supply

Set nominal CT secondary current to either 5 A or 1 A, and nominal system frequency to either 60 Hz or 50 Hz. This example uses 5 A/ 60 Hz.

## Calibration

The relay is calibrated before it leaves the factory; but if component changes are made within the relay, you may need to do a re-calibration.

Before you begin a new calibration, establish the accuracy of the equipment being used.

To perform a calibration, you must be logged into the relay in Terminal Mode at the Service access level. Proceed to the *Utilities>Maintenance>Calibrate*. The Calibrate menu leads you through every analog input and prompts you to apply the appropriate quantity.

```

COM2 - HyperTerminal
File Edit View Call Transfer Help
[Icons]
LPRO Unit ID: UnitID
.../Util/Maintenance      User Access Level:SERVICE      2003Jun23 13:21
prev menu Calibrate      Outputs Control Virtual Inputs Erase

-Calibration
>Main VA
Main VB
Main VC
Main IA Calibrate AC Input Channel
Main IB                               Channel: Main VA
Aux. IA Enter Actual Applied Signal Level ( 69 Vrms nominal): 69.00 Vrms
Aux. IB
Aux. IC
IA3
IB3
IC3
IA4
IB4
IC4
Aux. VA
v

<ENTER> Calibrate <F2> Accept <F3> Quit
Connected 1:56:02 VT100 98400 8-N-1 SCROLL CAPS NUM Capture Print echo

```

Figure 6.1: Enter actual applied signal level

```

LPRO Unit ID: UnitID
.../Util/Maintenance      User Access Level:SERVICE      2003Jun23 13:22
prev menu Calibrate      Outputs Control Virtual Inputs Erase

-Calibration
>Main VA
Main VB
Main VC
Main IA Calibrate AC Input Channel
M-Status Message
M
A Calibrate error. Gain reading +0.00 out of range (+55.20 to +82.80)
A
A
I
IB3
IC3
IA4
IB4
IC4
Aux. VA
v

<ENTER> Calibrate <F2> Accept <F3> Quit

```

Figure 6.2: Calibration error - out of range

For example, when you select voltage VA for calibration, a prompt appears which asks you which quantity the relay should try to calibrate. If a 66 V phase-to-neutral quantity is applied to the back VA terminals, 66.0 V would be indicated as the desired calibration.

In a similar way, you are prompted to go through all 18 ac analog quantities and provide the information about the injected calibration quantities. You must have a test source to perform this function. Only the magnitude of the analog input requires calibration, not the angle.

When an analog input channel is calibrated, you can verify the quantity measured by selecting the Metering menu and the Analog Quantity submenu. VA of the ac voltage input is used as a reference quantity by L-PRO. Therefore, if it is absent, there is not a locked, valid relationship among all of the analog quantities.

### **Testing the External Inputs**

To test the external inputs connect the relay to a laptop in *Terminal Mode, Service level>Metering>I/O*. This screen displays the status of the Input and Output Contacts. Placing a voltage of 125 Vdc nominal, (150 V maximum), to each of the external inputs in turn causes the input to change from Low to High status. These inputs are polarity sensitive and this screen has a 0.5 second update rate.

### **Testing the Output Relay Contacts**

Test the output relays to verify their integrity using the *Utilities>Maintenance>Outputs*. The output contacts are closed by pressing the *Enter* key. Toggle the output contacts from open to closed by pressing the *Enter* key. Verify the output contact status using an ohmmeter. When you exit this sub-menu, each contact status reverts to the open position.

## L-PRO Acceptance Test Procedure Outline

- Devices to Test:**
- 60 AC Loss of Potential
  - 21P Phase-to-Phase Impedance
  - 21N Phase-to-Neutral Impedance
  - Weak Infeed
  - Dead Line Pickup
  - 68 Out Of Step
  - 27 Undervoltage
  - 59 Overvoltage
  - 50N/51N Neutral Overcurrent
  - 50/51 Phase Overcurrent
  - 46-50/46-51 Negative Sequence Overcurrent
  - 50LS Low Set Definite Time Overcurrent
  - 50BF Breaker Fail
  - Example of Inputs 3 and 4 being used for Breaker Fail
  - 81 Over/Under/Rate of Change of Frequency
  - 25C Sync Check
  - 79 Recloser

### Download Acceptance Test File

- 1 Browse to find the following *Offliner* Setting file “LPROaccTestsetting60hz” in C:\Program Files\ERLPhase\L-PRO Settings.
- 2 Double-click the Setting file to open. Enter the serial number of the relay you’re testing or check “Ignore Serial Number” checkbox.

Figure 6.3: Identification Serial Number Screen

- 3 Save the file.
- 4 Connect to the L-PRO in Service or Change mode via the L-PRO front port (Port 1) using your terminal program’s Zmodem (e.g. HyperTerminal or Procomm).

- 5 From the Main Menu select *Settings*.
- 6 From the Settings submenu select *Load From Offliner*.
- 7 Select *Y*, yes you are ready to continue.
- 8 Find *Send File* in your terminal software (e.g. for HyperTerminal under “Transfer”).

### About the Acceptance Test Setting File

The acceptance test setting file provided is not necessarily configured to provide a realistic setting example. Its configuration is intended to demonstrate simple test methods for each relay element. Tests are organized to prevent interference of one protection element on the next within the relay for ease of testing without using multiple setting files and minimizing the number of test connection changes. All contacts in the relay will be tested if all elements in this procedure are tested as written.

Testing all the elements is accommodated by using of the L-PRO Setting Groups (3 groups are used).

Setting Group 1 tests elements: 21P, 21N, 68, 60, Dead Line Pickup, Weak In-feed

Setting Group 2 tests elements: 46-50/46-51, 50/51, 50N/51N, 27, 59, 50LS, 50BF

Setting Group 3 tests elements: 25/27/59 (Sync Check), 79, 81

The file demonstrates all types of impedance characteristics available in the L-PRO: circle, tomato, lens, quadrilateral.

Virtual Inputs are used to perform some input functions and demonstrate their use.

In addition to, or exclusive of these tests, you may wish to perform dynamic simulation tests on the L-PRO to verify the relay operates as per protection scheme design using the settings that are applied for the particular line on which the L-PRO will be installed.

**Impedance Characteristics Available in L-PRO (Mho and Quadrilateral)**

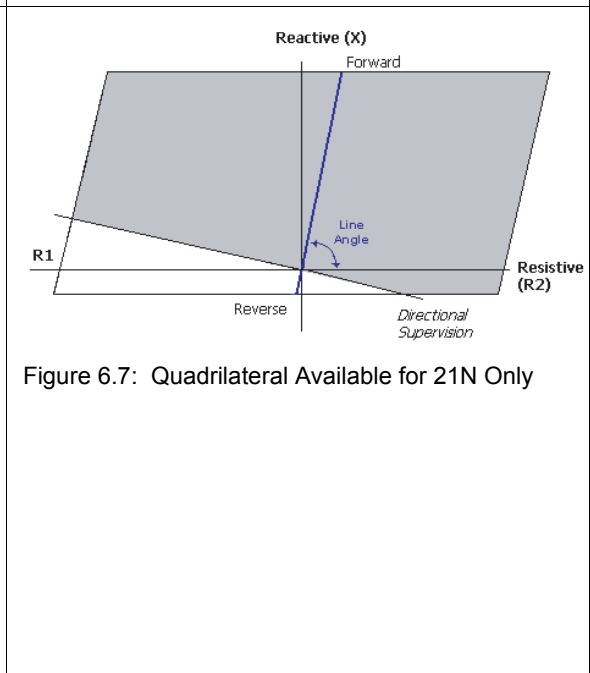
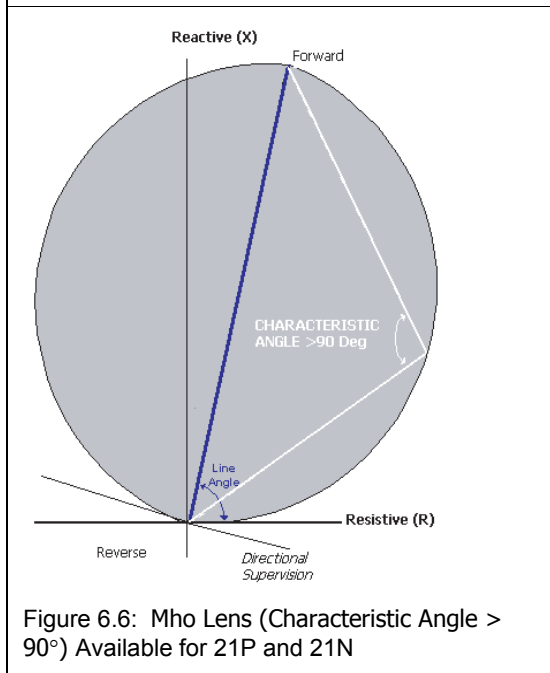
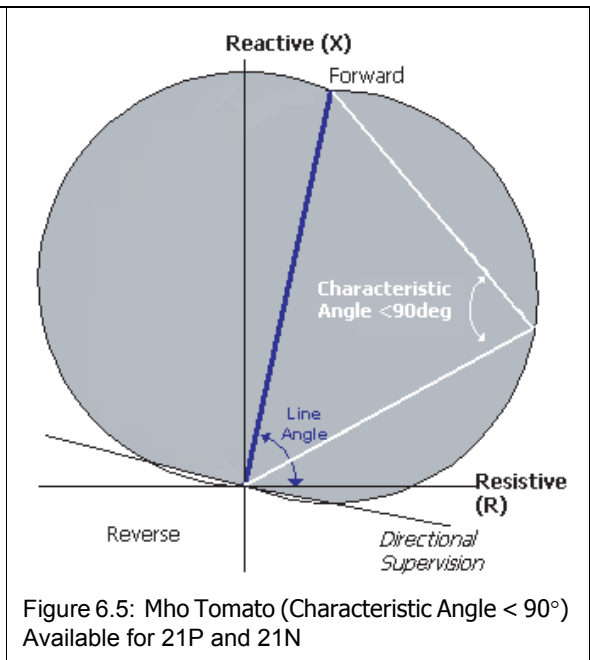
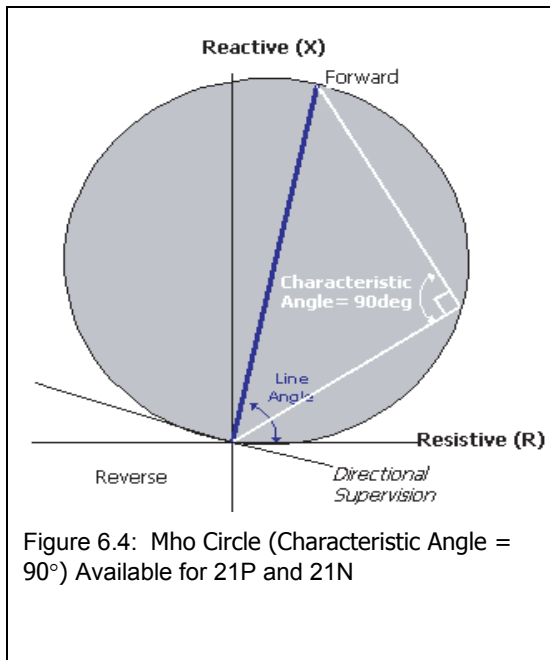

## Basic Testing Calculations

$$\text{Nominal primary voltage} = 230kV$$

$$\text{Nominal secondary phase-to-phase voltage} = \frac{kV}{PTRatio} = \frac{230kV}{2000} = 115V$$

$$\text{Nominal secondary phase-to-neutral voltage} = \frac{115V}{\sqrt{3}} = 66.4V$$

Zero Sequence Impedance calculations for phase-to-ground impedance element tests (using secondary Positive and Zero Sequence Line Impedances):

$$Z1 = 5.9\Omega\angle 80^\circ = (1.03 + j5.81)$$

$$Z0 = 16.0\Omega\angle 74^\circ = (4.41 + j15.38)$$

Equation 1	$K0 = \frac{Z0 - Z1}{3 \times Z1}$
------------	------------------------------------

$$= \frac{[(4.41 - 1.03) + (j15.38 - j5.81)]}{3 \times 5.9\angle 80^\circ} = \frac{3.38 + j9.57}{17.7\angle 80^\circ} = \frac{10.15\angle 70.52^\circ}{17.7\angle 80^\circ} = (0.57\angle -9.5)$$

The multiplier used to compensate phase-to-ground impedances:

Equation 2	$1 + K0$
------------	----------

$$= (1 + 0.57\angle -9.5^\circ) = (1 + 0.562 - j0.094) = (1.562 - j0.094) = 1.569\angle -3.5^\circ$$

### 21N Reach Settings

Zone 1 Reach: Mho 4.72  $\Omega$

Zone 2 Reach: Quadrilateral X: 7.38  $\Omega$ , R: 6.00  $\Omega$

Zone 3 Reach: Mho Forward 17.7  $\Omega$ , Reverse 0.50  $\Omega$

Zone 4 Reach: Mho Forward 0.00  $\Omega$ , Reverse 4.72  $\Omega$

Compensated 21N1 setting 4.72  $\Omega$  (Zone 1 phase-to-ground compensated Mho impedance):

$$4.72\Omega\angle 80^\circ \times 1.569\angle -3.5^\circ = 7.40\Omega\angle 76.5^\circ$$

Compensated 21N2 Setting  $7.38 \Omega$  (Zone 2 phase-to-ground compensated quadrilateral impedance):

Reactive:  $7.38 \Omega \angle 80^\circ \times 1.569 \angle -3.5^\circ = 11.58 \Omega \angle 76.5^\circ$

Resistive:  $6.0 \Omega \angle 0^\circ \times 1.569 \angle -3.5^\circ = 9.41 \Omega \angle -3.5^\circ$

The pure resistive component  $9.41 \Omega \times \cos(-3.5^\circ) = 9.39 \Omega \angle 0^\circ$

Compensated 21N3 (Zone 3 Phase-to-ground compensated impedance):

Forward:  $17.70 \Omega \angle 80^\circ \times 1.569 \angle -3.5^\circ = 27.76 \Omega \angle 76.5^\circ$

Reverse:  $0.50 \Omega \angle -100^\circ \times 1.569 \angle -3.5^\circ = 0.78 \Omega \angle -103.5^\circ$

Compensated 21N4 (Zone 4 phase-to-ground compensated impedance)

Forward: 0 (must be 0 for POTT Scheme)

Reverse:  $4.72 \Omega \angle -100^\circ \times 1.569 \angle -3.5^\circ = 7.40 \Omega \angle -103.5^\circ$

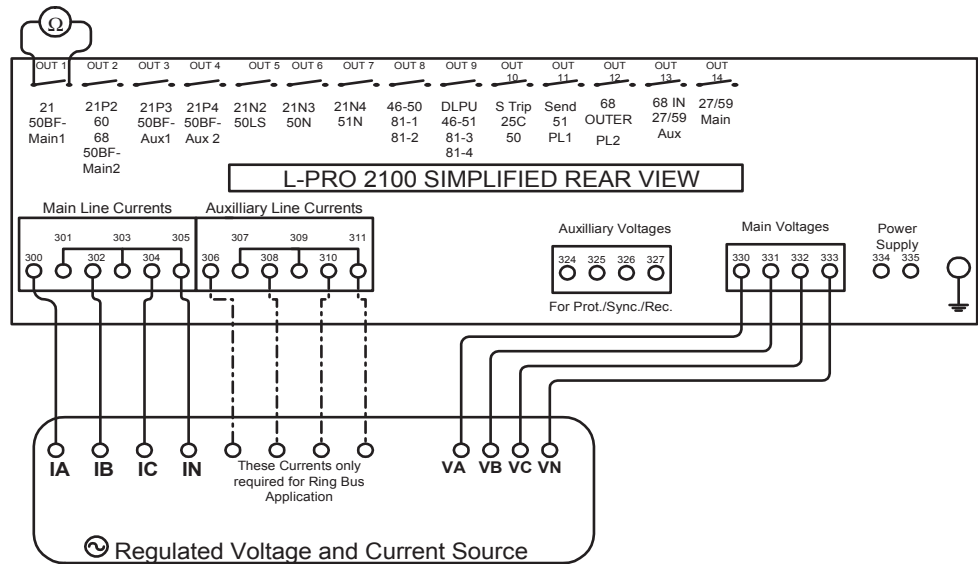

Figure 6.8: Suggested Test Connections for Acceptance Tests



Where each test specifies Metering/Logic, you view the following terminal screens (the Protection Logic is broken up into 2 screens to allow all elements to be displayed).

```

LPRO Unit ID: R00001
.../Logic/Protection      User Access Level:SERVICE      2002Aug19 09:10
prev menu  Logic 1  Logic 2

Logic 1
-----
Trips                Alarms                Trips
-----
21P1                LOW                50BF Main-1        LOW
21P2                LOW                50BF Main-2        LOW
21P3                LOW                21P3 Pickup        LOW
21P4                LOW                21P4 Pickup        LOW
21N1                LOW                50BF Aux-1         LOW
21N2                LOW                21N2 Pickup        LOW
21N3                LOW                21N3 Pickup        LOW
21N4                LOW                21N4 Pickup        LOW
51                  LOW                51 Pickup          LOW
51N                 LOW                51N Pickup         LOW
46-51               LOW                46-51 Pickup       LOW
50                  LOW                60                 LOW
50N                 LOW                68 OutBlinder     LOW
46-50               LOW                68 InnBlinder     LOW
68 Out of Step     LOW
-----
<F3> Quit <F2> Freeze

```

```

LPRO Unit ID: R00001
.../Logic/Protection      User Access Level:SERVICE      2002Aug19 09:06
prev menu  Logic 1  Logic 2

Logic 2
-----
Other Logic          Other Logic
-----
252759 Sync Check   LOW                Z Circle Trigger   LOW
27 Main U/U         LOW
27 Aux. U/U         LOW
59 Main O/U         LOW
59 Aux. O/U         LOW
50BF Initiate      LOW
50LS Main           LOW
50LS Aux.           LOW
79 Initiated        LOW
79 Blocked          LOW
79 Lead Lockout     LOW
79 Follow Lockout   LOW
79 Main Reclose     LOW
79 Aux. Reclose     LOW
Com. Scheme Send    LOW
-----
<F3> Quit <F2> Freeze

```

Figure 6.9: Logic Metering Screens

## 60 Loss of Potential (LOP) Test

### Settings

- Voltage = 0.75 per unit phase-to-neutral fixed (In this case minimum operate = 0.75 per unit =  $0.75 * V_{\text{nominal}} = 0.75 * 66.4 \text{ V} = 49.8 \text{ V}$ )
- I1 Blocking = 10.0 A (positive sequence current that blocks LOP if exceeded)
- 3I0 Blocking = 1.0 A (zero sequence current that blocks LOP if exceeded)

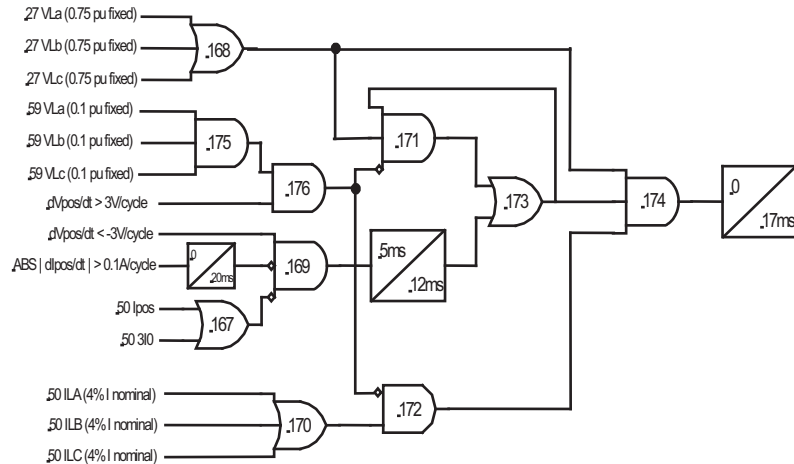

Figure 6.10: Loss of Potential Logic (60)

### 60 Test Procedure:

- 1 In Terminal Mode access relay *Metering>Logic>Protection>Logic1*.  
Monitor: 60 Alarm
- 2 Apply balanced 3-phase nominal voltages (66.4 V) to the L-PRO terminals:
  - Ph A: 330, 66.4 V  $\angle 0^\circ$
  - Ph B: 331, 66.4 V  $\angle -120^\circ$
  - Ph C: 332, 66.4 V  $\angle +120^\circ$
  - Ph N: 333
- 3 Connect 3-phase current sources (0.5 A) to the L-PRO terminals (must be greater than 0.2 A (4% Inominal) to enable due to low set supervision, for details see for details see Figure 6.10: Loss of Potential Logic (60) on page 6-10).
  - Ph A: 300 – 301, 0.5 A  $\angle 0^\circ$
  - Ph B: 302 – 303, 0.5 A  $\angle -120^\circ$
  - Ph C: 303 – 304, 0.5 A  $\angle +120^\circ$
 Observe: 60 Alarm = Low
- 4 Instantaneously reduce single-phase voltage to 48 V or less.  
60 Alarm = High  
Contact 2 Closed

**Testing the LOP I1 Supervision:**

- 1 Restore 3-phase voltages to 66.4 V.  
Observe 60 Alarm = Low  
Contact 2 = Open
- 2 Increase balanced 3-phase currents to 10.1 A per phase.
- 3 Reduce single-phase voltage to 0.  
Observe 60 Alarm remains low  
Observe Contact 2 remains open
- 4 Reduce currents to 0.

**Testing the LOP 3IO Supervision**

- 1 Restore 3-phase voltages to 66.4 V.  
Observe 60 Alarm = Low  
Contact 2 = Open
- 2 Increase any single-phase current to 1.1 A.
- 3 Reduce single-phase voltage to 0.  
Observe 60 Alarm remains low.  
Observe Contact 2 remains open.
- 4 Reduce all sources to 0.

End of 60 test.

**21P1 Phase Distance Test**

(Zone 1 Single-Phase Under Impedance Test tested as 3-phase fault)

**Settings**

- Positive Sequence Secondary Line Impedance (100% of line)= 5.9  $\Omega$
- Positive Sequence Line Angle = 80°
- 21P1 = 4.72  $\Omega$  (Maximum Reach = 80% of line at maximum torque angle of 80°)
- Time Delay = 0 (expect 1.3 cycles, 22 ms or less)
- Delta Current Supervision = 7.0 A (minimum phasor difference between any 2 phases to allow 21P Trip)

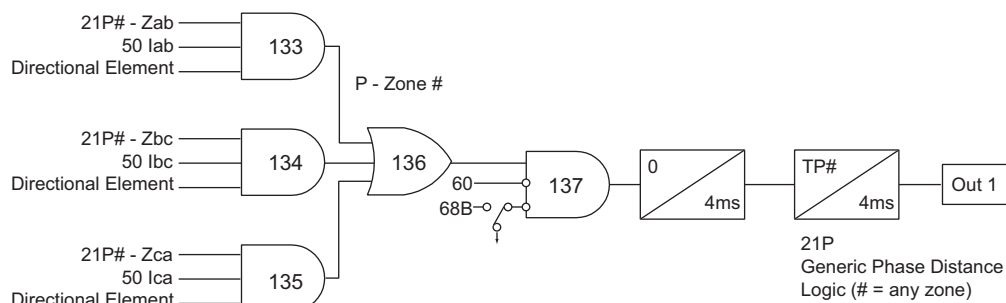

Figure 6.11: Phase Distance Logic (21P)

### Preliminary Calculations

Since this is a balanced 3-phase test, there is no Zero Sequence Current, so  $Z$  is calculated as:

$$Z = \frac{V_{Phase}}{I_{Phase}}$$

The minimum 3-phase current required is:

(Remember: I Delta is the phasor difference between any 2-phase currents; add 5% to ensure the Minimum I Delta Supervision Logic is high for this test.)

$$I_{min} = \frac{I_{DeltaSupervision} \times 105percent}{\sqrt{3}} = \frac{7.0 \times 1.05}{\sqrt{3}} = 4.24amps$$

### 21P1 Test Procedure

- 1 In Terminal Mode access relay *Metering>Logic>Protection>Logic1*.  
Monitor 21P1 Trip
- 2 Apply balanced 3-phase nominal voltages (66.4 V) to the L-PRO terminals.
  - Ph A: 330, 66.4 V  $\angle 0^\circ$
  - Ph B: 331, 66.4 V  $\angle -120^\circ$
  - Ph C: 332, 66.4 V  $\angle +120^\circ$
  - Ph N: 333
- 3 Connect 3-phase current sources (4.24 A lagging voltages by  $80^\circ$ ) to the L-PRO terminals:
  - Ph A: 300 – 301, 4.24 A  $\angle -80^\circ$
  - Ph B: 302 – 303, 4.24 A  $\angle -200^\circ$
  - Ph C: 303 – 304, 4.24 A  $\angle +40^\circ$
 Observe 21P1 Trip = Low
- 4 Simultaneously reduce 3-phase voltages.  
At 21.0 to 19.0 V (expect 20.0 V)
  - 21 Trip = High (Note that Contact 1 will probably close earlier than 21-1 Trip going high, because Z2 and Z3 trip elements are mapped to the same output contact, and the length of time this fault will be applied.)

**Testing the Zone 1 Phase Time Delay**

- 1 Monitor (Timer Stop) on normally open Output Contact 1 (202–203).
- 2 Set timer to start from 3-phase amp current transition (i.e. current off to on).
- 3 Apply (keep on) balanced 3-phase voltages (20.0 V) to the L-PRO terminals.

Ph A: 330, 20.0 V  $\angle 0^\circ$

Ph B: 331, 20.0 V  $\angle -120^\circ$

Ph C: 332, 20.0 V  $\angle +120^\circ$

Ph N: 333

- 4 Apply 3-phase currents from 0 to 5.3 A to start the timer (this is 80% of Zone 1 Reach = 64% of the line = 12.4 miles).

Ph A: 300 – 301, 5.3 A  $\angle -80^\circ$

Ph B: 302 – 303, 5.3 A  $\angle -200^\circ$

Ph C: 303 – 304, 5.3 A  $\angle +40^\circ$

Expect operating time less than 1.3 cycles with CCVT algorithm disabled.

End of 21P1 test.

**21P2 Phase Distance Test****Zone 2 Phase Under Impedance tested as 2-phase fault****Settings**

- Positive Sequence Secondary Line Impedance (100% of line) = 5.9  $\Omega$  Positive Sequence Line Angle (Z1) = 80°
- 21P2 = 7.38  $\Omega$  (Maximum Reach = 125% of line, 24.25 miles at maximum torque angle of 80°)
- Time Delay = 400 ms (expect 1.0 to 1.3 cycle additional delay due to inherent detection and contact times)
- Delta Current Supervision = 3.0 A (minimum phasor difference between any 2 phases to allow 21P2 Trip)

This test example shows how to test for a phase-to-phase fault.

Determine the voltage and current quantities required to perform this test.

- 1 Determine the minimum current required (as per Idelta supervision setting).
- 2 Determine an appropriate fault voltage to use for the test.
- 3 Determine the 3-phase voltage phasors required to create the fault voltage.

- 1 Minimum current required for this test:

Idelta Supervision Setting (the phasor difference of 2 phases) = 3.0 A. Current is injected into polarity of B-phase and out of polarity of C-phase.

Therefore B-phase and C-phase currents are equal in magnitude but 180° out of phase.

The minimum delta current required = 3.0 A; add 5% to ensure supervision is met:

$$3.0 \times 105\text{percent} = 3.2\text{amps}$$

Since B-phase = C-phase, actual minimum current required =

$$\frac{3.2}{2} = 1.6\text{amps}$$

- Use the minimum test current to determine what voltage would be appropriate for this test.

Equation 5	$Z = \frac{V_{\text{faultmin}}}{2 \times I_{\text{testmin}}}$
------------	---

From Equation 5 we can derive the formula:

$$V_{\text{faultmin}} = Z \times 2 \times I_{\text{testmin}}$$

$$V_{\text{faultmin}} = 7.38\Omega \times 2 \times 1.6A = 23.6\text{volts}$$

- Now determine the 3-phase voltage phasors.

Only B-C fault is shown here, but the same principle applies for A-B or C-A faults.

Since neutral is not involved in this type of fault, the faulted voltage phasors collapse toward each other along the phase-to-phase line.

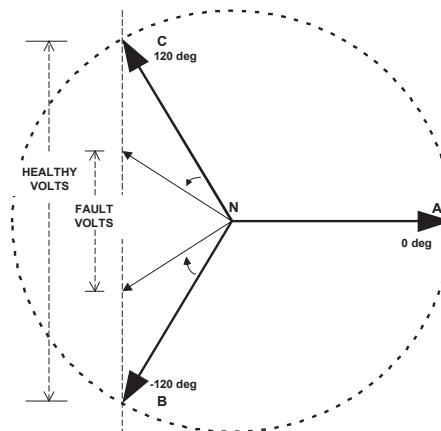

Figure 6.12: Phasor Representation of an Ideal Phase-to-Phase Fault

The following tables show the voltages to inject for a variety of fault voltage levels using 115 V secondary phase-to-phase nominal (66.4 V phase-to-neutral nominal).

<b>A-B Fault</b>									
<b>(C-phase voltage = 66.4 V <math>\angle</math>+120°) The resultant angle of A-B voltage always = +30°</b>									
<b>% Reduction</b>	<b>10%</b>	<b>20%</b>	<b>30%</b>	<b>40%</b>	<b>50%</b>	<b>60%</b>	<b>70%</b>	<b>80%</b>	<b>90%</b>
Fault Volts	103.5 V	92.0 V	80.5 V	69.0 V	57.5 V	46.0 V	34.5 V	23.0 V	11.5 V
Fault Volt Angle	30°	30°	30°	30°	30°	30°	30°	30°	30°
Voltage A=B	61.5 V	56.7 V	52.2 V	47.9 V	43.9 V	40.4 V	37.4 V	35.1 V	33.7 V
A Angle	-2.7°	-5.8°	-9.5°	-13.9°	-19.1°	-25.3°	-32.5°	-40.9°	-50.2°
B Angle	-117.3°	-114.2°	-110.5°	-106.1°	-100.9°	-94.7°	-87.5°	-79.1°	-69.8°

<b>B-C Fault</b>									
<b>(A phase voltage = 66.4V<math>\angle</math>0°) The resultant angle of B-C voltage always = -90°</b>									
<b>% Reduction</b>	<b>10%</b>	<b>20%</b>	<b>30%</b>	<b>40%</b>	<b>50%</b>	<b>60%</b>	<b>70%</b>	<b>80%</b>	<b>90%</b>
Fault Volts	103.5 V	92.0 V	80.5 V	69.0 V	57.5 V	46.0 V	34.5 V	23.0 V	11.5 V
Fault Volt Angle	-90°	-90°	-90°	-90°	-90°	-90°	-90°	-90°	-90°
Voltage B=C	61.5 V	56.7 V	52.2 V	47.9 V	43.9 V	40.4 V	37.4 V	35.1 V	33.7 V
B Angle	-122.7°	-125.8°	-129.5°	-133.9°	-139.1°	-145.3°	-152.5°	-160.9°	-170.2°
C Angle	122.7°	125.8°	129.5°	133.9°	139.1°	145.3°	152.5°	160.9°	170.2°

<b>C-A Fault</b>									
<b>(B phase voltage = 66.4V <math>\angle</math>-120°) The resultant angle of C-A voltage always = +150°</b>									
<b>% Reduction</b>	<b>10%</b>	<b>20%</b>	<b>30%</b>	<b>40%</b>	<b>50%</b>	<b>60%</b>	<b>70%</b>	<b>80%</b>	<b>90%</b>
Fault Volts	103.5 V	92.0 V	80.5 V	69.0 V	57.5 V	46.0 V	34.5 V	23.0 V	11.5 V
Fault Volt Angle	150°	150°	150°	150°	150°	150°	150°	150°	150°
Voltage C=A	61.5 V	56.7 V	52.2 V	47.9 V	43.9 V	40.4 V	37.4 V	35.1 V	33.7 V
C Angle	117.3°	114.2°	110.5°	106.1°	100.9°	94.7°	87.5°	79.1°	69.8°
A Angle	2.7°	5.8°	9.5°	13.9°	19.1°	25.3°	32.5°	40.9°	50.2°

For this B-C test a minimum fault voltage of 23.6 V is required as calculated in the table, “B-C Fault” on page 6-15. Select the next highest voltage. In this case 34.5 V (70% reduction) is used.

The following formulae were used to calculate the voltages for the tables (they may be used for any other desired fault voltage): Test voltage magnitude:

Equation 3	$\sqrt{\left(\frac{V_{fault}}{2}\right)^2 + \left(\frac{V_{nominal}}{2}\right)^2}$
------------	--

Note:  $V_{fault}$  = phase-to-phase fault voltage and  $V_{nominal}$  = phase-to-neutral nominal voltage.

### Test Phase Angle

Offset the nominal phase angles toward the other faulted phase angle by:

Equation 4	$60^\circ - \text{atan}\left(\frac{V_{fault}}{V_{nominal}}\right)$
------------	--

Example of this calculation using the 70% voltage reduction from the B-C fault table: Phase B-C voltage angle =  $-90^\circ$  with respect to A-N voltage phasor.

Fault Voltage = 70% reduction of phase-to-phase nominal

$$= 115V - (\angle -90^\circ) - (115V + \angle -90^\circ \times 70\text{percent}) = (34.5V \angle -90^\circ)$$

$$\text{Faulted Test Voltage Magnitudes} = \sqrt{\left(\frac{34.5}{2}\right)^2 + \left(\frac{66.4}{2}\right)^2} = \sqrt{1399.8} = 37.4V$$

$$\text{Faulted Phase Angle} = 60^\circ - \text{atan}\left(\frac{34.5}{66.4}\right) = 60^\circ - 27.5^\circ = 32.5^\circ$$

For B-C fault adjust Phase B angle toward Phase C angle and adjust Phase C angle toward Phase B angle:

$$\text{B Phase Angle} = -120^\circ - 32.5^\circ = -152.5^\circ$$

$$\text{C Phase Angle} = +120^\circ + 32.5^\circ = 152.5^\circ$$

So,

$$\text{A Phase Phasor} = \text{Unfaulted} = 66.4 V \angle 0^\circ$$

$$\text{B Phase Phasor} = \text{Faulted} = 37.4 V \angle -152.5^\circ$$

$$\text{C Phase Phasor} = \text{Faulted} = 37.4 V \angle +152.5^\circ$$



## Connecting the Test Source for B-C Fault:

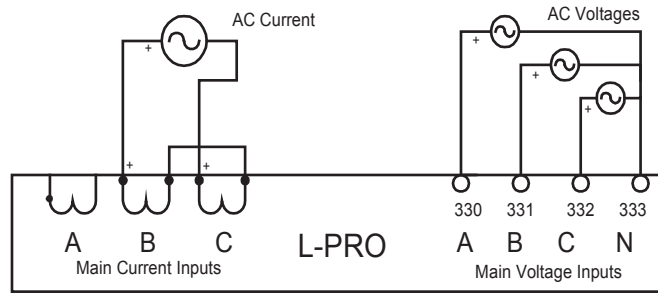

Figure 6.13: AC Connections to L-PRO for B-C (21P) Test

In summary for this example, inject Phase B to Phase C fault:

Line Impedance =  $7.38 \Omega$

Line Angle =  $80^\circ$

Fault Voltage =  $34.5 \text{ V} \angle -90^\circ$  using the calculated voltage phasors

Fault Current = greater than  $1.6 \text{ A} \angle (-90^\circ - 80^\circ) = \text{greater than } 1.6 \text{ A} \angle -170^\circ$

**21P2 Test Procedure**

- 1 In Terminal Mode access relay *Metering>Logic>Protection>Logic1*.  
Monitor the following element for pickup: 21P2 Pickup.
  - 2 Apply the following 3-phase voltages to the L-PRO main ac volts terminals:
    - Ph A: 330,  $66.4 \text{ V} \angle 0^\circ$
    - Ph B: 331,  $37.4 \text{ V} \angle -152.5^\circ$
    - Ph C: 332,  $37.4 \text{ V} \angle +152.5^\circ$
    - Ph N: 333
  - 3 Connect variable single-phase current source (lagging phase-to-phase fault voltage by  $80^\circ$ ) to the L-PRO main line current terminals (Jumper Terminals 303 & 305):
    - Ph B-C: 302 – 304,  $1.5 \text{ A} \angle -170^\circ$
    - Observe 21P2 Alarm = Low
  - 4 Increase current.
    - At 2.23 to 2.45 A (expect 2.34 A):
    - 21P2 Alarm = High
  - 5 Turn off voltage and current sources.
- End of 21P2 test.

## 21N2 Ground Distance Test

### Zone 2 Phase-to-Neutral Under Impedance

#### Settings

- Positive Sequence Secondary Line Impedance (100% of line) = 5.9 Ω
- Positive Sequence Line Angle (Z1) = 80°
- 21N2 = 7.38 Ω (Maximum Reach = 125% of line at maximum torque angle of 80°) compensated as per 21N calculations to: 11.58 Ω ∠76.5°
- Resistive Component compensated to: 9.41 Ω ∠-3.5°
- Time Delay = 0 (expect 1.3 cycles, 22 ms or less)
- 3I0 Current Supervision = 1.5 A (minimum zero sequence current to allow 21N2 to operate)
- I Phase Current Supervision = 1.5 A (minimum phase current to allow 21N2 to operate)

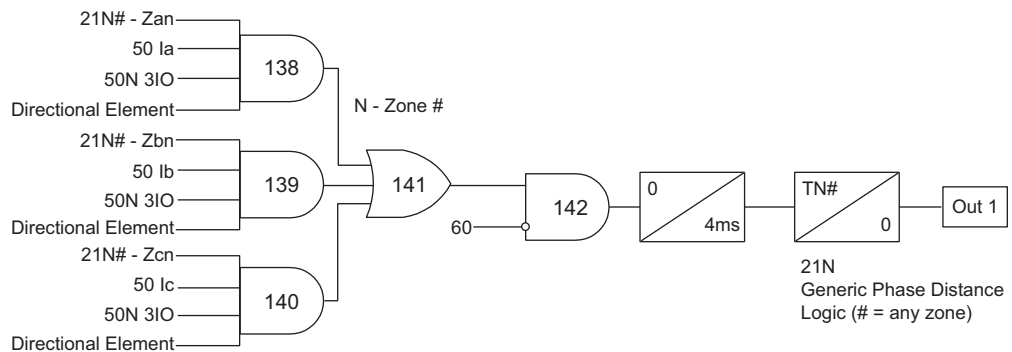

Figure 6.14: Ground Distance Logic (21N)

This test demonstrates testing a single line (Phase A) to a ground fault.

#### Preliminary calculations

Since this is a single-phase test, use the compensated impedance value calculated above; the calculated Z is:

$$Z_{fault} = \frac{V_{fault}}{I_{fault}}$$

The minimum single-phase current required is:

(Remember: Testing single-phase, so need to exceed the greater of I phase and 3I0 supervision settings; add 5% to ensure the minimum supervision logic is high for this test.):

$$I_{min} = \text{Greater of Phase and 3I0 Supervision} \times 105\text{percent} = 1.5 \times 1.05 = 1.58A$$

This element has been set for quadrilateral characteristic.

**21N2 Reactive Test Procedure**

- 1 In Terminal Mode access relay *Metering>Logic>Protection>Logic1*.  
Monitor: 21N2 Pickup
- 2 Apply balanced 3-phase nominal voltages (66.4 V) to the L-PRO terminals.  
Ph A: 330, 66.4 V  $\angle 0^\circ$   
Ph B: 331, 66.4 V  $\angle -120^\circ$   
Ph C: 332, 66.4 V  $\angle +120^\circ$   
Ph N: 333
- 3 Connect single-phase current source to the L-PRO terminals.  
Ph A: 300 – 301, 1.58 A  $\angle -76.5^\circ$   
Observe 21N2 Pickup = Low
- 4 Reduce Phase A voltage.  
At 17.4 to 19.2 V (expect 18.3 V):  
21N2 Pickup = High (After 400 ms: 21N2 Trip = High)

**21N2 Resistive Test Procedure**

- 1 In Terminal Mode access relay *Metering>Logic>Protection>Logic1*.  
Monitor: 21N2 Pickup
- 2 Apply balanced 3-phase nominal voltages (66.4 V) to the L-PRO terminals.  
Ph A: 330, 66.4 V  $\angle 0^\circ$   
Ph B: 331, 66.4 V  $\angle -120^\circ$   
Ph C: 332, 66.4 V  $\angle +120^\circ$   
Ph N: 333
- 3 Connect single -phase current source to the L-PRO terminals.  
Ph A: 300 – 301, 1.58 A  $\angle +3.5^\circ$   
Observe 21N2 Pickup = Low
- 4 Reduce Phase A voltage.  
At 15.6 to 14.2 V (expect 14.9 V).  
21N2 Pickup = High  
After 400 ms: 21N2 Trip = High

**Testing the Zone 2 Neutral Time Delay**

- 1 Monitor (Timer Stop) on normally open Output Contact 1 (202 – 203).
- 2 Set timer to start from single-phase current transition (i.e. current off to on).
- 3 Apply the following 3-phase voltages to the L-PRO terminals.  
Ph A: 330, 66.4 V  $\angle 0^\circ$   
Ph B: 331, 66.4 V  $\angle -120^\circ$   
Ph C: 332, 66.4 V  $\angle +120^\circ$   
Ph N: 333

- 4 Apply single-phase current from 0 to 6.0 A to start the timer (95% of Zone 2 Reach = 119% of the line = 23.1 miles).

Ph A: 300 – 301, 6.0 A  $\angle -76.5^\circ$

Expected operate time = (400 ms + 1.0 to 1.3 cycle) = 417 ms ( $\pm 2.5\%$ )

Note: The zone timer starts when the fault is detected; the detection time + inherent contact time = approximately 1.0 to 1.3 cycles after fault inception.

### Testing Other Zones

You can test all other zones (21P3-4) and (21N1 and 21N3-4) using the same process as the 21P1, 21P2 and 21N2 zones, except that you need to substitute the impedance and timing settings for those zones.

End of 21 tests.

### Weak Infeed Test

Weak Infeed tripping operates on 4 basic conditions:

- 1 Low Positive Sequence Voltage (27V1) or High Neutral Voltage (59V0)
- 2 No Zone 2 or Zone 4 reverse element picked up.
- 3 Loss of Potential (60) element dropped out
- 4 Permissive trip received from the remote end

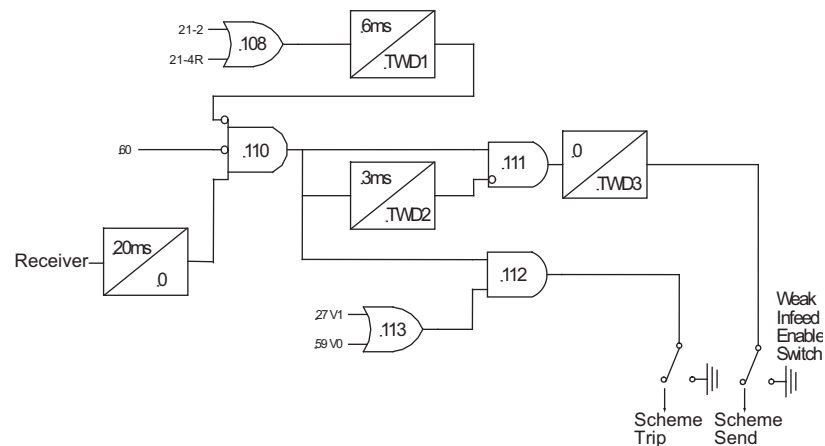
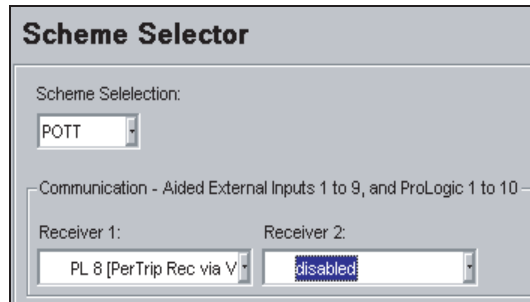

Figure 6.15: Weak Infeed Logic

For this test apply 0 voltage and 0 current to the relay with no prefault. This causes the first 3 conditions to be met: (27V1, NOT (Zone 2 OR Zone 4R), NOT Loss of Potential).

In this case a Virtual Input is set up to simulate the Permissive Trip Receive contact via ProLogic.

Figure 6.16: Scheme Selector Settings (*Offliner*)

### Weak Infeed Test Procedure

- 1 Activating this Virtual Input by accessing the L-PRO Terminal Mode *Utilities*>*Maintenance*>*Control Virtual Inputs*.
- 2 Press the <Enter> or the <Space> keys to scroll Virtual Inputs to the Input Name “PerTripRec Simulate” (Virtual Input 13).
- 3 Press the <Arrow>key to activate the action section. Select the *Pulse On* option.
- 4 Press the <F2> Key to execute the “PerTripRec Simulate” as shown in the following screen shot.

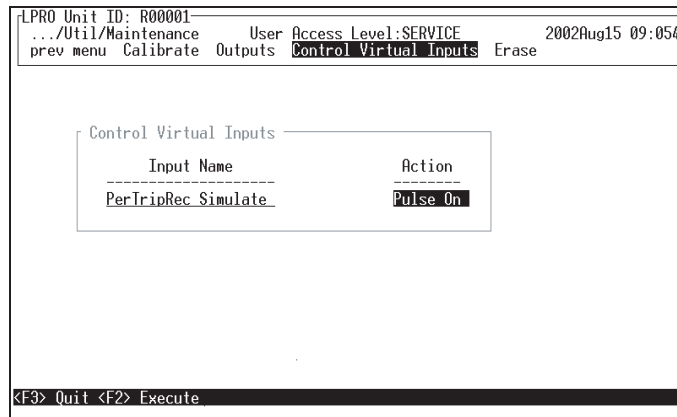

Figure 6.17: Virtual Input Control (HyperTerminal)

Observe Relay Target: “POTT Trip (WI): 0.0 mi.

Note: The 0.0 mi indicates that there was 0 impedance measured due to 0 line voltage being applied.

End of Weak Infeed test.

## Dead Line Pickup Test

Dead Line Pickup operates on 3 basic conditions:

- 1 Zero Positive Sequence Polarizing Voltage (27Vpos) for at least 2 seconds prior to line energization
- 2 Zero Current (less than 4% of nominal) prior to the application of the fault (i.e. line goes from “dead” to energized state: 50ILa, b, c)
- 3 Instantaneous Phase or Neutral Overcurrent settings (within the Dead Line Pickup screen) are exceeded within 200 ms of line energization

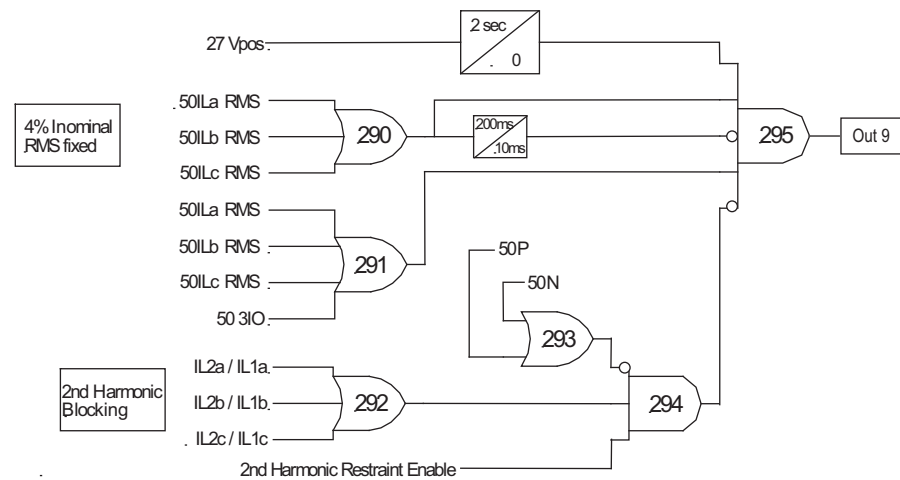

Figure 6.18: Dead Line Pickup Logic

Figure 6.19: Dead Line Pickup Settings (*Offliner*)

### Dead Line Pickup Test Procedure

- 1 Apply 0 voltage to the relay voltage inputs.
- 2 Instantaneously step single-phase current from 0 to 0.95 A to:

$$\text{Ph A: } 300 - 301, 0.95 \text{ A } \angle \text{any}^\circ$$

Observe target “Dead Line Pickup on A”.

End of Dead Line Pickup test.

**68 Out of Step Test**

(Set to trip for this test.)

**Settings**

- Outer Right Blinder = 17  $\Omega$
- Outer Left Blinder = -17  $\Omega$
- Inner Right Blinder = 13  $\Omega$
- Inner Left Blinder = -13  $\Omega$
- Swing timer = 1.0 second
- I1 Supervision (positive sequence current) = 3.0 A
- 3I0 Supervision = 1.0 A

Note: Out of Step Blinders are Positive Sequence Impedance Quantities.

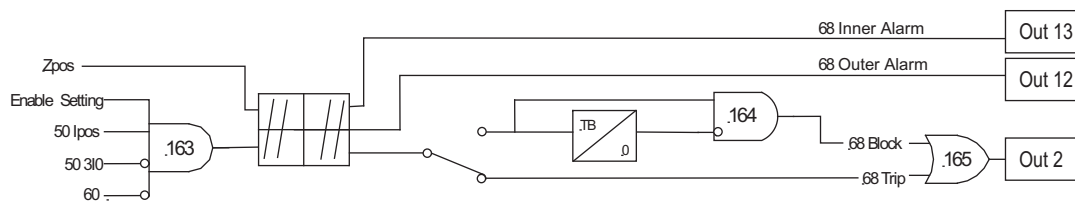

Figure 6.20: Out of Step Logic (68)

**Preliminary Calculations**

Because this is a Positive Sequence Impedance, perform this test as balanced 3-phase, since this is the easiest way to obtain positive sequence. The calculated Z is:

$$Z = \frac{V_{phase}}{I_{phase}}$$

The minimum 3-phase current required must be greater than the I1 Supervision Setting (3.0 A).

Add 5% to ensure that the supervision is met:

$$I_{min} = I_{supervision} \times 105\text{percent} = 3.0 \times 1.05 = 3.15A$$

**68 Outer Right Test Procedure**

- 1 In Terminal Mode access relay *Metering>Logic>Protection>Logic1*.

Monitor:

68 OutBlinder Alarm

Contact 12 with an ohmmeter

- 2 Apply balanced 3-phase nominal voltages (66.4 V) to the L-PRO terminals.

Ph A: 330, 66.4 V  $\angle 0^\circ$

Ph B: 331, 66.4 V  $\angle -120^\circ$

Ph C: 332, 66.4 V  $\angle +120^\circ$

Ph N: 333

- 3 Connect 3-phase current sources (3.15 A in phase with voltages) to the L-PRO terminals.:Ph A: 300 – 301, 3.15 A  $\angle 0^\circ$   
Ph B: 302 – 303, 3.15 A  $\angle -120^\circ$   
Ph C: 303 – 304, 3.15 A  $\angle +120^\circ$   
Observe 68 OutBlinder Alarm = Low  
Contact 12 = Open
  - 4 Simultaneously increase (ramp up) 3-phase currents.  
At 3.72 to 4.10 A (expect 3.91A):  
68 OutBlinder Alarm = High  
Contact 12 = Closed
- End of 68 Outer test.

### 68 Inner Left Test Procedure

- 1 Terminal Mode access relay *Metering>Logic>Protection>Logic1*.  
Monitor:  
68 InnBlinder Alarm.  
Output Contact 13 with an ohmmeter.
- 2 Apply balanced 3-phase nominal voltages (66.4 V) to the L-PRO terminals:  
Ph A: 330, 66.4 V  $\angle 0^\circ$   
Ph B: 331, 66.4 V  $\angle -120^\circ$   
Ph C: 332, 66.4 V  $\angle +120^\circ$   
Ph N: 333
- 3 Connect 3-phase current sources (3.15 A  $\angle 180^\circ$  from voltages) to the L-PRO terminals.  
Ph A: 300 – 301, 3.15 A  $\angle 180^\circ$   
Ph B: 302 – 303, 3.15 A  $\angle +60^\circ$   
Ph C: 303 – 304, 3.15 A  $\angle -60^\circ$   
Observe 68 InnBlinder Alarm = Low  
Contact 13 = Open
- 4 Simultaneously increase (ramp up) 3-phase currents.  
At 4.86 to 5.36 A (expect 5.11 A):  
68 InnBlinder Alarm = High  
Contact 13 = Closed



**Testing the 68 Swing Timer Delay**

- 1 Monitor (Timer Stop) on normally open Output Contact 2 (204 – 205).
- 2 Test at impedance between Inner and Outer Right Blinders =  $15 \Omega \angle 0^\circ$
- 3 Set timer to start from 3-phase current transition (i.e. current off to on).
- 4 Apply (keep on) balanced 3-phase voltages (66.4 V) to the L-PRO terminals.

Ph A: 330, 66.4 V  $\angle 0^\circ$

Ph B: 331, 66.4 V  $\angle -120^\circ$

Ph C: 332, 66.4 V  $\angle +120^\circ$

Ph N: 333

- 5 Apply 3-phase currents from 0 to 4.43 A to start the timer.

Ph A: 300 – 301, 4.43 A  $\angle 0^\circ$

Ph B: 302 – 303, 4.43 A  $\angle -120^\circ$

Ph C: 303 – 304, 4.43 A  $\angle 120^\circ$

Expect operating time 1.0 second + inherent 1.0 to 1.3 cycle detection time.

Observe target: “68 Out Of Step: Trip”.

End of 68 Swing Timer test.

**Change Setting Group**

For the next group of tests using the Acceptance Test file you must change to Setting Group 2.

- 1 In Service mode access *Utilities>Maintenance>Control Virtual Inputs*.
- 2 Use the *<Enter>* key to scroll Input Name to “Switch to SG2”.
- 3 Cursor over to Action and select “Pulse On”.
- 4 Press *<F2>* to execute this command; the Active Setting Group will become Group 2.

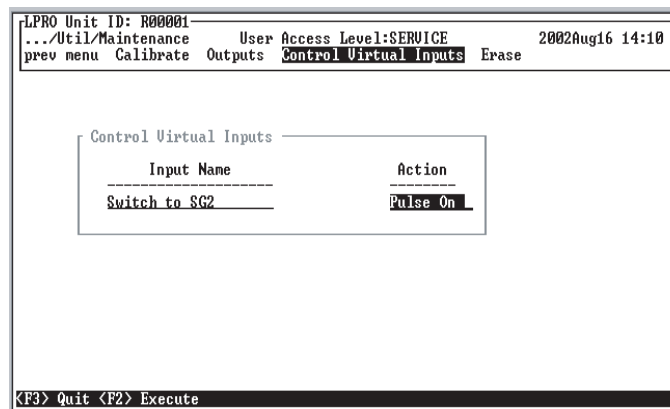

Figure 6.21: Change Setting Groups via Virtual Inputs (HyperTerminal)

- 5 Confirm the Active Setting Group in *Settings>Active Group*.  
Note: you can also change the Active Setting Group in this screen.

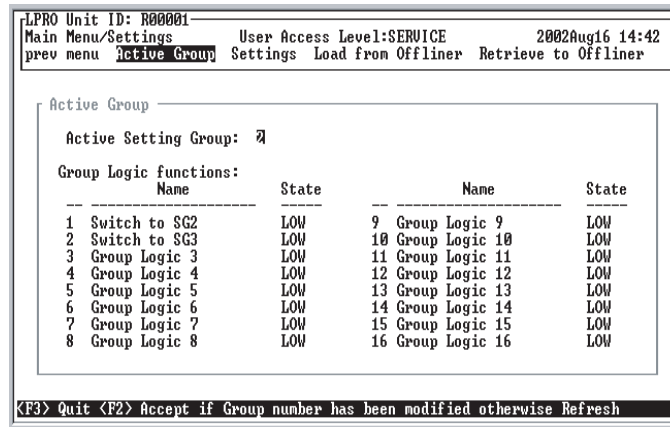

Figure 6.22: Group Logic Metering (HyperTerminal)

## 27 Undervoltage Test

### Settings

- Main: AND (3-Phase Undervoltage)
- Auxiliary: AND (Single-Phase Undervoltage; Only 1 phase is connected)
- Main and Aux Pickup: 30 V
- Time Delay: 0.01 second

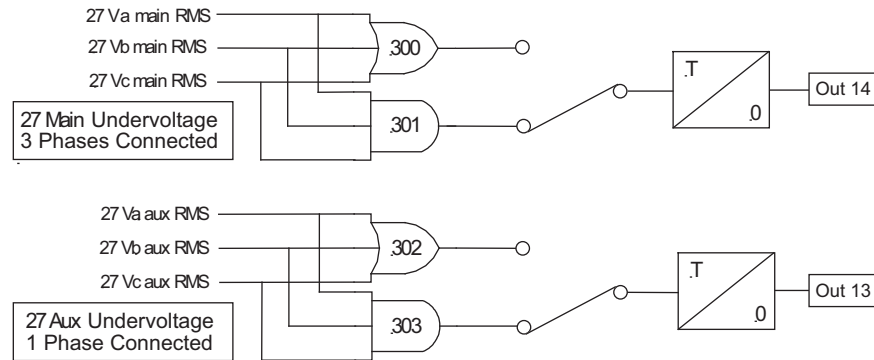

Figure 6.23: Undervoltage Logic (27)

**27 Test Procedure**

- 1 Terminal Mode access relay *Metering>Logic>Protection>Logic2*.

Monitor:

27 Main U/V

27 Aux U/V

Monitor Output Contacts:

13 (27 Aux Trip)

14 (27 Main Trip)

- 2 Apply balanced 3-phase nominal voltages (66.4 V) to the L-PRO terminals.

Ph A: 324 and 330, 66.4 V  $\angle 0^\circ$

Ph B: 331, 66.4 V  $\angle -120^\circ$

Ph C: 332, 66.4 V  $\angle +120^\circ$

Ph N: 327 and 333

Observe:

27 Main U/V = Low

27 Aux U/V = Low

- 3 Reduce A Phase voltage.

At 31.0 to 29.0 V (expect 30 V):

27 Aux U/V = High

Contact 13 closed

27 Main U/V remains Low

Contact 14 open

4 With A Phase voltage still reduced, reduce B and C phase volts:

At 31 to 29 V (expect 30 V):

27 Aux U/V = High

27 Main U/V = High

Contact 14 closed

End of 27 test.

## 59 Overvoltage Test

### Settings

- Main: AND (3-Phase Overvoltage)
- Auxiliary: OR (Single-Phase Overvoltage – 1 phase connected)
- Main and Aux Pickup: 72 V
- Time Delay: 0.05 second

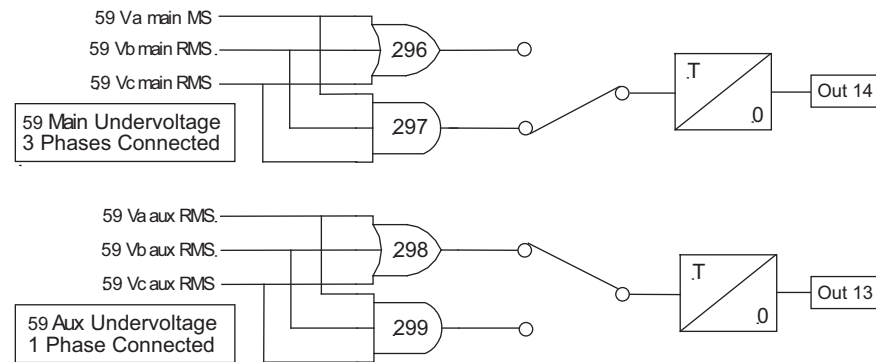

Figure 6.24: Overvoltage Logic (59)

### 59 Test Procedure

1 In Terminal Mode access relay *Metering>Logic>Protection>Logic2*.

Monitor:

59 Main O/V

59 Aux O/V

Monitor contacts:

Output 13 (59 Aux Trip)

Output 14 (59 Main Trip)

2 Apply balanced 3-phase nominal voltages (66.4 V) to the L-PRO terminals.

Ph A: 324 & 330, 66.4 V  $\angle 0^\circ$

Ph B: 331, 66.4 V  $\angle -120^\circ$

Ph C: 332, 66.4 V  $\angle +120^\circ$

Ph N: 327 and 333

Observe:

59 Main O/V = Low

59 Aux O/V = Low

- 3 Increase A Phase voltage:
    - At 70.0 to 74.0 V (expect 72 V):
      - 59 Aux O/V = High
      - Contact 13 = Closed
      - 59 Main O/V remains Low
      - Contact 14 = Open
  - 4 With A Phase voltage still increased, increase B and C phase volts.
    - At 70 to 74 V (expect 72 V):
      - 59 Aux O/V = High
      - 59 Main O/V = High
      - Contact 14 = Closed
- End of 59 test.

### 50N/51N Neutral Overcurrent Test

### Neutral Instantaneous and Time Overcurrent Test

#### Settings

- Both Directional
- 50N Pickup = 10.0 A
- 51N Pickup = 1.0 A
- Time Curve = IEEE Moderately Inverse
  - A = 0.0103
  - B = 0.0228
  - p = 0.02
  - TMS = 3.0

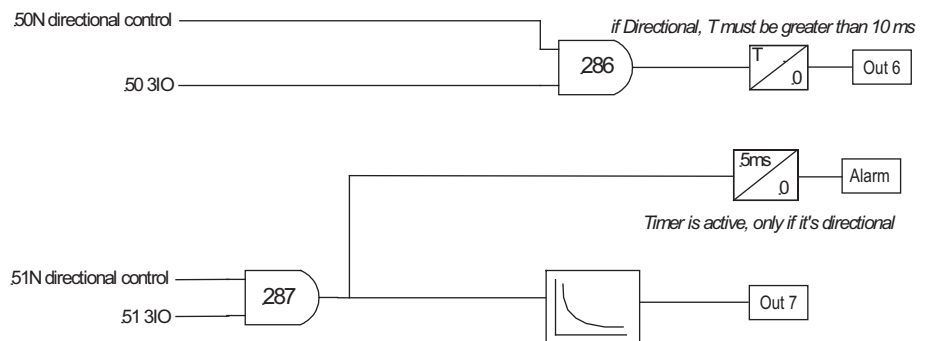

Figure 6.25: Neutral Instantaneous and Time Overcurrent Logic (50N/51N)

**50N and 51N Test Procedure**

Note: with 0 voltage applied, the unit becomes non-directional (i.e. picks up in both forward and reverse directions).

- 1 In Terminal Mode access relay *Metering>Logic>Protection>Logic1*.

Monitor:

51N Alarm

Output Contact 6 (50N Trip)

- 2 Apply single-phase current to the L-PRO terminals as follows:

Ph A: 300 – 301, 0.5 A

- 3 Slowly ramp the current up.

At 0.95 to 1.05 A (expect 1.0 A):

51N Alarm = High

- 4 Continue to raise current.

At 9.5 to 10.5 A (expect 10.0 A):

50N Trip = High

Contact 6 = Closed

- 5 Turn current off.

51N Alarm = Low

50N Trip = Low

**Timing Test**

- 1 Monitor (Timer Stop) on Output Contact 7.
- 2 Set timer start from single-phase 0.0 A to 4.00 A transition (this equates to 4x pickup).

Time Delay

$$= TMS \times \left[ B + \frac{A}{(I_{multiple})^p - 1} \right] = 3 \times \left[ 0.0228 + \frac{0.0103}{4^{0.02} - 1} \right] = 3 \times \left[ 0.0228 + \frac{0.0103}{0.0281} \right] = 1.168s$$

- 3 Inject fault.

Observe Relay Target: “51N Trip”

End of 50N/51N test.

## 50/51 Phase Overcurrent Test

(Phase Instantaneous and Time Overcurrent) Test

### Settings

- Only 51 Directional
- 50 Pickup = 15.0 A
- 51 Pickup = 1.5 A
- Time Curve = IEC Very Inverse
  - A = 13.5
  - B = 0.00
  - p = 1.0
  - TMS = 0.5

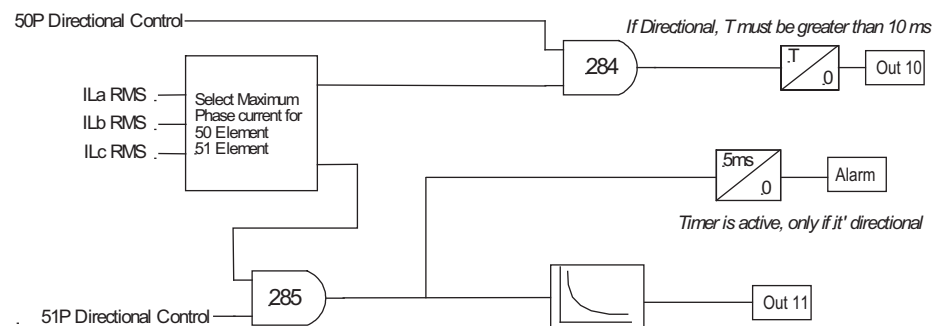

Figure 6.26: Phase Instantaneous and Time Overcurrent Logic (50/51)

### 50 and 51 Test Procedure

- 1 In Terminal Mode access relay *Metering>Logic>Protection/Logic1*.

Monitor:

51 Alarm.

Output Contact 10 (50 Trip).

- 2 Apply single-phase current to the L-PRO terminals.

Ph A: 300 – 301, 0.5 A

- 3 Slowly ramp up the current.

At 1.43 to 1.58 A (expect 1.5 A):

51 Alarm = High

- 4 Continue to raise current.

At 14.3 to 15.8 A (expect 15 A):

50 Trip = High

Contact 10 = Closed

- 5 Turn current off.

51 Alarm = Low

50 Trip = Low

### 51 Timing Test

- 1 Monitor (Timer Stop) on Output Contact 11.
- 2 Set timer start from single-phase 0.0 A to 6.00 A transition (this equates to 4x pickup).

Time Delay

$$= TMS \times \left[ B + \frac{A}{(I_{multiple})^p - 1} \right] = 0.5 \times \left[ 0.00 + \frac{13.5}{4^1 - 1} \right] = 0.5 \times \left[ 0.00 + \frac{13.5}{3} \right] = 2.25s$$

- 3 Inject fault.

Observe Relay Target: “51 Trip on A”

### 51 Directional Test

#### Settings

- 51 Settings as above
- Line Angle = 80° (i.e. current lags voltage by 80°)

Note: Operating Range = ± 90° from line angle

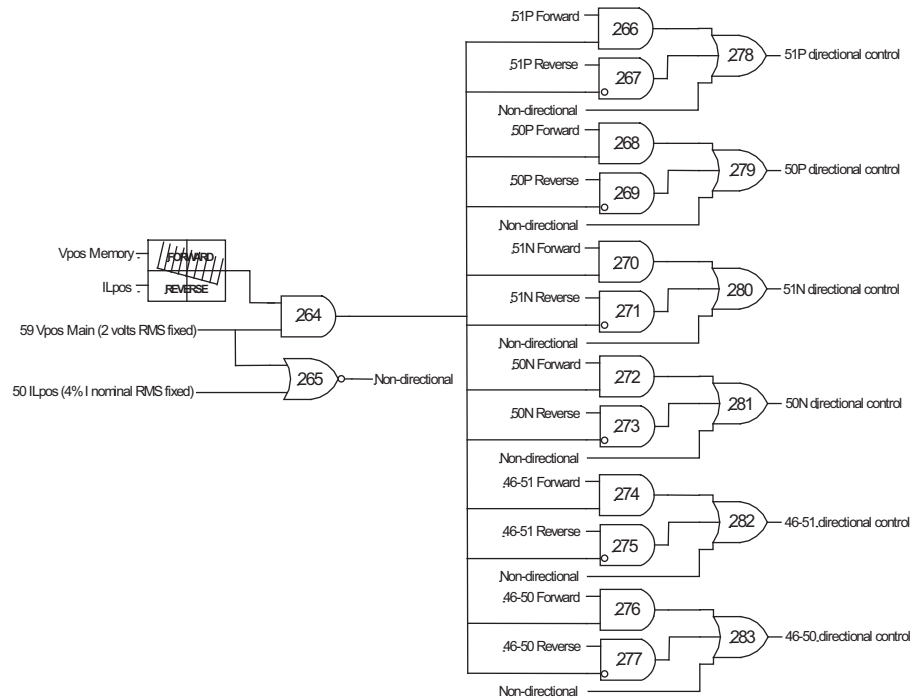

Figure 6.27: Directional Element Logic



**51 Directional Test Procedure**

- 1 In Terminal Mode access relay *Metering>Logic>Protection>Logic1*.  
Monitor: 51 Pickup Alarm
  - 2 Apply single-phase polarizing voltage to:  
Ph A: 330 – 333, 66.4 V  $\angle 0^\circ$
  - 3 Apply single-phase current at line angle to:  
Ph A: 300 – 301, 2.0 A  $\angle -80^\circ$   
Observe 51 Pickup Alarm = High
  - 4 Slowly ramp the current phase angle in negative direction (i.e. more lag):  
At  $-165^\circ$  to  $-175^\circ$  (expect  $-170^\circ$ ):  
51 Pickup Alarm = Low
  - 5 Restore current to line angle ( $-80^\circ$ ):  
Observe 51 Pickup Alarm = High
  - 6 Slowly ramp the current phase angle in positive direction (i.e. less lag):  
At  $+5^\circ$  to  $+15^\circ$  (expect  $+10^\circ$ ):  
51 Pickup Alarm = Low
  - 7 Turn off voltage and current sources.
- End of 50/51 test.

### 46-50/46-51 Negative Sequence Overcurrent Test

#### Settings

- Directional
- 46-51 Pickup = 1.0 A
- Time Curve = IEEE Extremely Inverse
  - A = 5.64
  - B = 0.02434
  - p = 2
  - TMS = 3.0

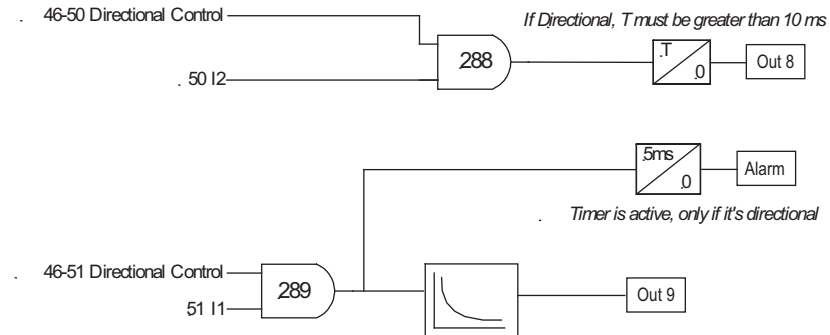

Figure 6.28: Negative Sequence Instantaneous and Time OverCurrent Logic (46-50/46-51)

Note that positive sequence current (50ILpos), 4% of nominal current is necessary to enable the directional element. This supervision can be seen on OR 265, for details see for details see Figure 6.27: Directional Element Logic on page 6-32.

For this test inject only single-phase current. This method introduces an equal proportion of positive and negative sequence current. This assures that there is sufficient positive sequence current to enable directional control of the negative sequence element, if a polarizing voltage is also applied.

Positive sequence (I1), Negative Sequence (I2), Zero Sequence (3I0) are calculated by using the following equations:

Equation 5	$I_1 = \frac{I_A + aI_B + a^2I_C}{3} \text{ where } a = 1 \angle 120^\circ$
------------	---

Equation 6	$I_2 = \frac{I_A + a^2I_B + aI_C}{3} \text{ where } a = 1 \angle 120^\circ$
------------	---

Equation 7	$3I_0 = I_A + I_B + I_C$
------------	--------------------------

Using Equation 6 notice that there is a need to triple the pickup setting current on one phase to obtain the pickup value of negative sequence current.

For example injecting 1.0 A on Phase A only (Phase B = Phase C = 0), and with no voltage applied, the 46-51 element becomes non-directional even though the setting is directional:

$$I_2 = \frac{1 + a^2 0 + a 0}{3} = \frac{1}{3} = 0.33A$$

#### 46-51 Test Procedure

- 1 In Terminal Mode access relay *Metering>Logic>Protection>Logic1*.  
Monitor: 46-51 Alarm
- 2 Apply single-phase current to the L-PRO terminals as follows:  
Ph A: 300 – 301, 2.5 A
- 3 Slowly ramp the current up:  
At 2.9 to 3.1 A (expect 3.0 A):  
46-51 Pickup Alarm = High
- 4 Turn current source off.

#### 46-51 Timing Test

- 1 Monitor (Timer Stop) on Output Contact 9.
- 2 Set timer start from single-phase 0.0 A to 12.00 A transition (this equates to 4x pickup).

Time Delay

$$= TMS \times \left[ B + \frac{A}{(I_{multiple})^p - 1} \right] = 3.0 \times \left[ 0.02434 + \frac{5.64}{4^2 - 1} \right] = 3.0 \times \left[ 0.02434 + \frac{5.64}{15} \right] = 1.201s$$

- 3 Inject fault.  
Observe Relay Target: “46-51 Trip”  
End of 46-51 test.

## Directional Element Positive Sequence Current Supervision Threshold (50ILpos) Test

(see OR 265, for details see Figure 6.27: Directional Element Logic on page 6-32)

### Settings

- Directional
- 50ILpos (Positive Sequence (I1) Low Set = 0.2 A fixed)
- 46-50 Pickup = 5.0 A

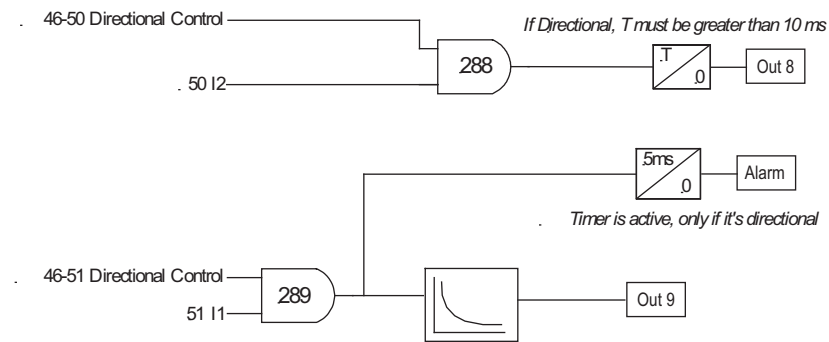

Figure 6.29: Negative Sequence Instantaneous and Time OverCurrent Logic (46-50/46-51)

### Test Calculations

The L-PRO directional element has a fixed positive sequence current setting of 4% of Inominal that is used to supervise the directional control. If the positive sequence current falls below 4% of Inominal, the directional control becomes non-directional. So, for directional control of the 46 element, you require:

Negative Sequence Current (I2) greater than pickup AND Positive Sequence Current (I1) greater than or equal to 0.2 A (4% Inominal).

For this test inject a Reverse Negative Sequence fault:

With the I1 Directional Supervision threshold not exceeded, the directional unit is disabled, therefore the directional element will be non-directional. This means that the 46 element is able to operate in the reverse direction as well as in the forward direction.

When the I1 Directional Supervision is exceeded, the 46 drops out as it has now become Directional (forward) only.

Testing is accomplished by applying 3-phase balanced I2 quantities sufficient to pickup the 46 element and then increasing the magnitude of any single-phase.

For example, for our 46-50 pickup of 5.0 A, use I2 of 5.1 A. This is sufficient I2 magnitude to solidly pickup the 46-50 element at the line angle. Note, that the line angle is the Positive Sequence Forward Direction but is the Negative Sequence Reverse Direction:

$$\begin{aligned} I_A &= 5.1 \text{ A } \angle -80^\circ \\ I_B &= 5.1 \text{ A } \angle +40^\circ \\ I_C &= 5.1 \text{ A } \angle +160^\circ \end{aligned}$$

The symmetrical components using Equations 5 to 7:

$$I1 = 0$$

$$I2 = 5.1 \text{ A } \angle -80^\circ$$

$$3I0 = 0$$

Now vary single-phase current to obtain sufficient I1 to enable the directional element (0.2 A).

Vary Phase A for this test.

**Redefine the symmetrical components to determine test quantities.**

Because IA will change, call it Inew.

IB and IC are equal and do not change so call them Iold.

$$I1 = \frac{|I_{new} - I_{old}|}{3}$$

$$I2 = \frac{|I_A| + |I_B| + |I_C|}{3} \text{ or } I2 = \frac{|I_{new}| + 2|I_{old}|}{3}$$

$$3I0 = |I_{new} - I_{old}|$$

Use the I1 formula to calculate Inew because we know the required value of I1 (0.2 A).

$$I_{old} = 5.1 \text{ A (I2 pickup plus margin)}$$

$$I1 = |I_{new} - I_{old}|/3$$

$$0.2 = |I_{new} - I_{old}|/3$$

$$I_{new} = 0.6 + 5.1$$

$$I_{new} = 5.7 \text{ A}$$

**Directional Element 50ILpos Threshold Test Procedure**

- 1 In Terminal Mode access relay *Metering>Logic>Protection>Logic1*.  
Monitor: 46-50 Trip
  - 2 Apply single-phase polarizing voltage to L-PRO terminals:  
Ph A: 330 – 333, 66.4 V  $\angle 0^\circ$
  - 3 Apply 3-phase negative sequence currents to L-PRO terminals:  
Ph A: 300 – 301, 5.1A  $\angle -80^\circ$   
Ph B: 302 – 303, 5.1A  $\angle +40^\circ$   
Ph C: 303 – 304, 5.1A  $\angle +160^\circ$   
Observe 46-50 Trip = High
  - 4 Slowly ramp up Phase A current to activate Directional Control:  
At 5.67 to 5.73 A (expect 5.7 A):  
46-50 Trip = Low
  - 5 Turn currents off.
- End of Directional 50ILpos Threshold test.

## 50BF (Breaker Fail) and 50LS (Low Set Overcurrent) Tests

### Settings

#### Main:

- 50LS Pickup: 1.0 A,
- Time Delay: 0.00 seconds
- 50BF Time Delay 1: 5.0 seconds
- 50BF Time Delay 2: 10.0 seconds

#### Auxiliary:

- 50LS Pickup: 1.0 A
- Time Delay: 0.00 seconds
- 50BF Time Delay 1: 5.0 seconds
- 50BF Time Delay 2: 10.0 seconds

#### Input 3:

- 50LS Pickup: 0.3 A
  - Time Delay: 1.00 second
- (50LS used with Virtual Input 3 to make Breaker Fail for Breaker 3)

#### Input 4:

- 50LS Pickup: 0.3 A
  - Time Delay: 1.00 second
- (50LS used with Virtual Input 4 to make Breaker Fail for Breaker 4)

Main and Aux. Breaker Fails are set to be initiated via the Output Matrix from 50LS Pickup (1.0 A Main and Aux and 0 time delay). Note: Requires a minimum of 0.2 A on any phase to arm Breaker Fail.

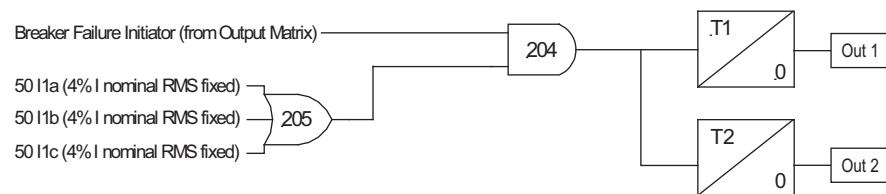

Figure 6.30: Main Breaker Fail Logic (50BF)

### 50BF and 50LS Test Procedure

- 1 In Terminal Mode access relay *Metering>Logic>Protection/Logic2*.

Monitor:

50LS Main

Output Contact 1 (50BF Main-1 Trip: A)

Output Contact 2 (50BF Main-2 Trip: A)

- 2 Apply single-phase current to the L-PRO terminals as follows:

Ph A: 300-301, 0.8 A

- 3 Slowly ramp the current up, at a rate of about 0.1 A per second:  
At 0.9 to 1.1 A (expect 1.0 A):  
50LS Main = High  
5 seconds later, Output Contact 1 = Closed (50BF Main-1 Trip)  
After an additional 5 seconds Output Contact 2 = Closed (50BF Main-2 Trip)
- 4 Turn current off.  
50LS Main = Low  
Contacts 1 and 2 = Open
- 5 The same 50BF procedure may be followed on the auxiliary input by injecting current into relay auxiliary current input, Terminals 306-307 and monitor Contacts 3 and 4.

### Testing Inputs 3 and 4 50LS Function

Inputs 3 and 4 50LS functions are used in a Breaker Fail Application using ProLogic.

The following screen shot shows the Logic being used to make a Breaker Fail application from the 50LS using ProLogic.

ProLogic 1: This boolean equation used to initiate and operate as a Breaker Fail for 52-3 (Input 3). Current above the 50LS threshold arms one input of the AND gate. The initiate in this case is provided by Virtual Input 3 which will latch until the current drops below the 50LS threshold.

Note: ProLogic 2 (not shown) is for 52-4 (Input 4).

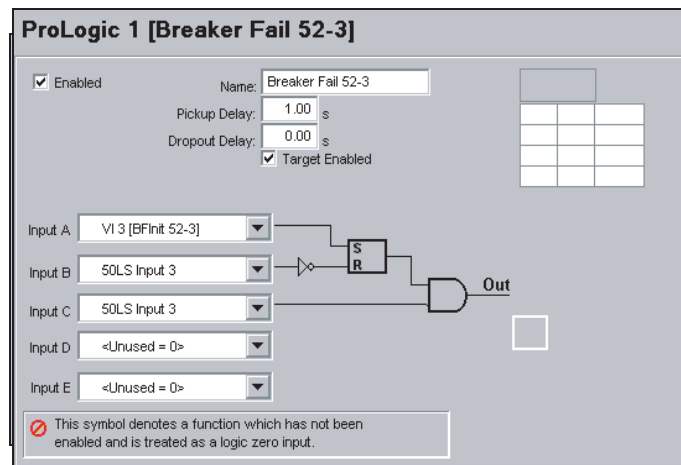

Figure 6.31: Breaker Fail Created Using ProLogic

**Input 3 Breaker Fail Test Procedure**

- 1 Apply 0.31 A to L-PRO Terminals 312 – 313.
  - 2 In Terminal Mode Service level access *Utilities>Maintenance>Control Virtual Inputs*.  
     Scroll to VI3 “Init BF 52-3”.  
     Pulse On.  
     Observe after 1 Second: Target “Breaker Fail 52-3: PL1”
  - 3 Reduce current to zero.
  - 4 Apply the same process to Input 4, Terminals 318 – 319, using VI4 “Init BF 52-4”.
- End of 50BF and 50LS tests.

For the next group of tests using the Acceptance Test file, you must change to Setting Group 3.

- 1 In Service mode access *Utilities>Maintenance>Control Virtual Inputs*.
- 2 Use the <Enter> key to scroll Input Name to “Switch to SG3”.
- 3 Cursor over to Action and select *Pulse On*.
- 4 Press <F2> to execute this command; the Active Setting Group now is Group 3.

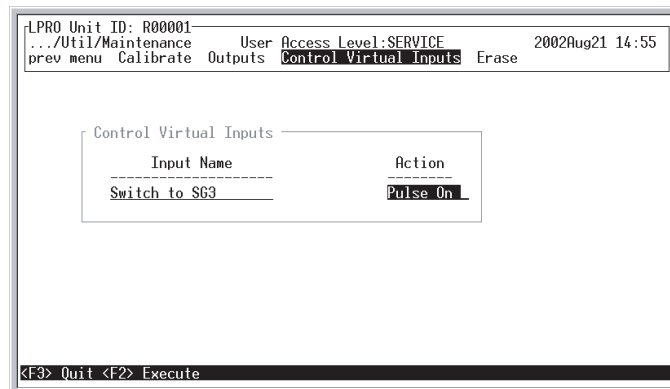

Figure 6.32: Control Virtual Inputs (HyperTerminal)

- 5 Confirm the Active Setting Group in *Metering>Logic>Setting Group*.  
 (Note: Active Setting Group cannot be changed in this screen).



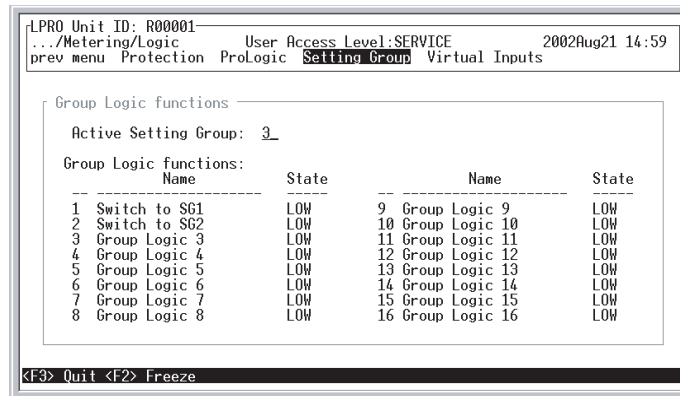

Figure 6.33: Group Logic Metering Screen. Confirm the Active Setting Group

## 81 Overfrequency and Underfrequency Test

### Settings

- 81-1 Pickup = 60.5 Hz Fixed Rate (50.5 Hz for 50 Hz Relay)
- 81-1 Time Delay = 0.5 second
- 81-2 Pickup = 59.5 Hz Fixed Rate (49.5 Hz for 50 Hz Relay)
- 81-2 Time Delay = 0.5 second
- 81-3 Pickup = +1.0 Hz/second
- 81-3 Time Delay = 0.2 second
- 81-4 Pickup = -1.0 Hz/second
- 81-4 Time Delay = 0.2 second

Requires minimum of 0.25 per unit positive sequence voltage (fixed setting) to enable the 81 element.

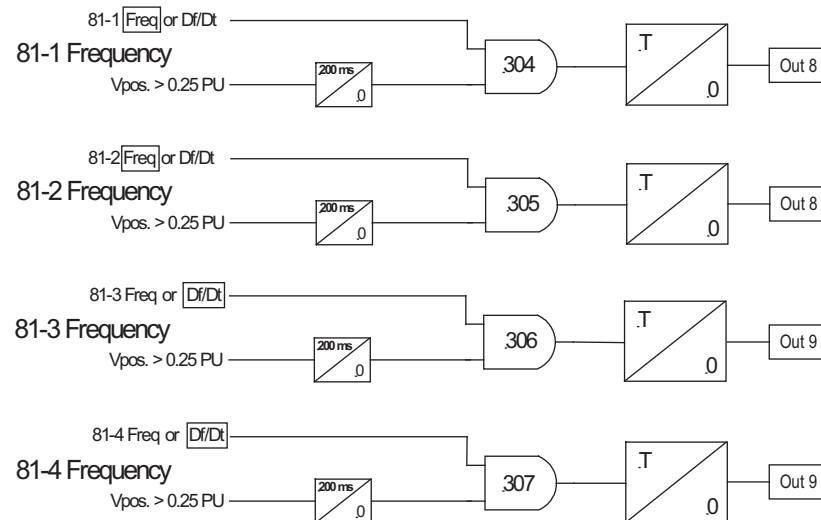

Figure 6.34: Over/Under/Rate of Change of Frequency Logic (81)

### 81 Fixed Rate Test Procedure

- 1 In Terminal Mode access relay *Metering>Logic>Protection>Logic1*.

Monitor:

81-1 Trip

Output Contact: 8

- 2 Apply single-phase nominal voltage to:

Ph A: 330 – 333, 66.4 V @ 60 Hz (@ 50 Hz for 50 Hz Relay)

81-1 = Low

81-2 = Low

- 3 Ramp up the voltage frequency.

At 60.499 to 60.501 Hz (50.499 to 50.501 Hz for 50 Hz relay):

81-1 = High

81-2 = Low

Contact 8 = Closed

- 4 Ramp down the voltage frequency.

At 59.501 to 59.499 Hz (49.501 to 49.499 Hz for 50 Hz Relay):

81-1 = Low

81-2 = High

Contact 8 = Closed

- 5 Turn voltage source off.

### 81 Rate of Change (df/dt) Test Procedure

- 1 In Terminal Mode access relay *Metering>Logic>Protection>Logic1*.

Monitor:

81-3 Trip

Contact: 9

- 2 Apply single-phase nominal voltage to the L-PRO terminals:

Ph A: 330 – 333, 66.4 V @ 60 Hz (50 Hz for 50 Hz Relay)

81-3 = Low

81-4 = Low

- 3 Ramp the frequency at a rate of +0.99 Hz/s for a duration of 2 seconds.

Observe:

81-3 = Low

81-4 = Low

Contact 9 = Open

- 4 Restore nominal frequency.

- 5 Ramp the frequency at a rate of +1.01 Hz/s for a duration of 2 seconds.

Observe:

81-3 = High

81-4 = Low

Contact 9 = Closed

- 6 Restore nominal frequency.
- 7 Ramp the frequency at a rate of  $-0.99$  Hz/s of a duration of 2 seconds.  
Observe:
  - 81-3 = Low
  - 81-4 = Low
  - Contact 9 = Open
- 8 Restore nominal frequency.
- 9 Ramp the frequency at a rate of  $-1.01$  Hz/s for a duration of 2 seconds.  
Observe:
  - 81-3 = Low
  - 81-4 = High
  - Contact 9 = Closed

### **81 Timing Test Procedure**

- 1 Monitor (Timer Stop) on Output Contact 8 (81-1).
  - 2 Set timer start on instantaneous frequency shift  $66.4$  V @  $60$  Hz to  $60.6$  Hz transition.  
Expect time delay of  $500$  ms + approximately  $1.5$  cycle detection time.
  - 3 Apply the frequency shift.  
Confirm the expected time delay.  
Target "81-1"
  - 4 Move (Timer Stop) to Output Contact 9 (81-2).
  - 5 Set timer start on instantaneous frequency shift  $66.4$  V @  $60$  Hz to  $59.4$  Hz transition.  
Expect time delay of  $500$  ms + approximately  $1.5$  cycle detection time.
  - 6 Apply the frequency shift.  
Confirm the expected time delay.  
Target "81-2"
- End of 81 test.

**25/27/59 Sync Check Test**

Note: Three or four voltage sources are required for this test.

The L-PRO will create the positive sequence sync check voltage out of the single-phase auxiliary voltage input depending on which phase is injected.

**Settings**

- Maximum voltage: 70 V sec. (Maximum Positive Sequence voltage)
- Minimum voltage: 40 V sec. (Minimum Positive Sequence voltage)
- Angle Difference: 20 degrees
- Time Delay: 200 milliseconds
- Dead Main Live Aux. (DMLA): Enable
- Live Main Dead Aux. (LMDA): Enable
- Dead Main Dead Aux. (DMDA): Enable

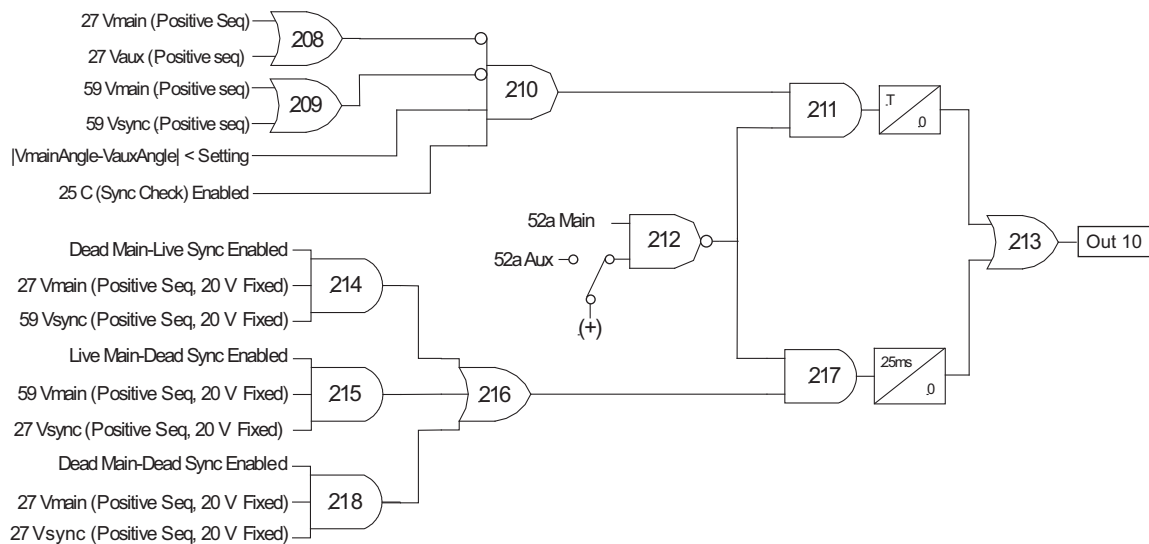

Figure 6.35: Synchronism Check Logic (25/27/59)

**Sync Check Test Procedure**

- 1 In Terminal Mode access relay *Metering>Logic>Protection>Logic2*.

Monitor:

25/27/59 Sync Check

Output Contact: 10

Observe 25/27/59 Sync Check = High (Proves DMDA with no voltage applied)

- 2 Apply voltages to the relay main voltage input terminals sufficient to create  $V_{pos}$  of 66.4 V.

If only 3 voltage sources are available:

Ph A: 330, 99.6 V  $\angle 0^\circ$

Ph B: 331, 99.6 V  $\angle -120^\circ$

Ph C: 332, not applicable

Ph N: 333

OR

If 4 voltage sources are available:

Ph A: 330, 66.4 V  $\angle 0^\circ$

Ph B: 331, 66.4 V  $\angle -120^\circ$

Ph C: 332, 66.4 V  $\angle +120^\circ$

Ph N: 333

Observe 25/27/59 Sync Check = High (Proves LMDA with only line voltage applied)

3 Turn voltage off.

4 Apply single-phase nominal voltage (66.4 V) to the relay auxiliary voltage input terminals.

Ph A: 324, 66.4 V  $\angle 25^\circ$

Ph N: 327

(Short and ground unused Terminals 325 and 326)

Observe 25/27/59 Sync Check = High (Proves DMLA with only bus-voltage applied)

5 Apply both sets of voltages to main and auxiliary inputs as detailed above.

Observe:

25/27/59 Sync Check = Low

6 Simultaneously rotate the auxiliary voltage phase angle in lagging direction (i.e. toward  $0^\circ$ ).

At  $21^\circ$  to  $19^\circ$  difference (expect  $20^\circ$ ):

25/27/59 = High

Contact 10 = Closed (after 200 ms)

7 Slowly ramp down the auxiliary voltage magnitude.

At 41.0 to 39.0 V (expect 40 V):

25/27/59 = Low

Contact 10 = Open

8. Slowly ramp up the auxiliary voltage magnitude.

At 69.0 to 71.0 V (expect 70 V):

25/27/59 = Low

Contact 10 = Open

8 Turn all voltage sources off.

End of Sync Check test.

**79 Recloser Test****Settings**

- Number of Shots: 4
- First Reclose (T1): 2.0 seconds
- Second Reclose (T2): 4.0 seconds
- Third Reclose (T3): 6.0 seconds
- Fourth Reclose (T4): 8.0 seconds
- Close time (Tp): 0.3 second
- Lockout Reset (TD): 12 seconds
- Initiate Reset (TDI): 1.0 second
- Sync Control: Enable
- Mode: Main then Aux.
- Block Reset (TDB): 1.0 seconds
- Follower Time (TF): 8.0 seconds
- Breaker Out Of Service (TC): 200 seconds
- Follower Sequencer: Close after Recloser Follower Time
- Main Breaker: EI1 [Breaker Status a]
- Aux Breaker: EI2 [Breaker Status a]

The following procedure allows you to test the Main and Auxiliary 4-shot reclosers, ending in 79 lockout.

The only test equipment required for this test is a 125 Vdc supply.

Output Contact 5 of the L-PRO relay is used to simulate the Main Breaker ‘a’ Contact and Output Contact 6 is used to simulate the Aux Breaker ‘a’ Contact. The Main Breaker Status is monitored by External Input 1; and Auxiliary Breaker Status is monitored by External Input 2.

Output 7 is used to simulate a protection operation. It supplies a trip command via External Input 3 and initiates the 79 operation.

Connect a 125 Vdc supply to the L-PRO relay output and input terminals as shown in for details see Figure 6.36: Test Connections for 4-Shot Recloser Test on page 6-46.

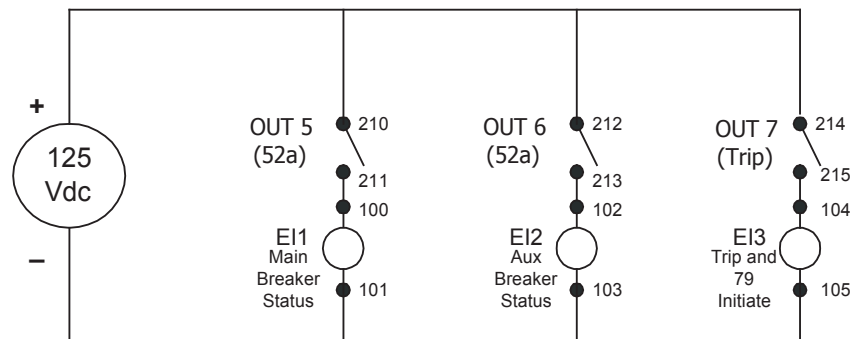

Figure 6.36: Test Connections for 4-Shot Recloser Test

ProLogic equations are used to activate and supervise the 79 test functions. Normally each of these ProLogic equations would not be set to target, but for this type of acceptance testing, it's convenient for seeing operations as they happen.

### Details of ProLogic Equations for this 79 Test Example

ProLogic 1: This equation activates the reclose sequence. It sets the breaker status (closes Out 5) via ProLogic 3.

**ProLogic 1 [Main Bkr Close]**

Enabled

Name:

Pickup Delay:  s

Dropout Delay:  s

Target Enabled

AND		
0	0	0
0	1	0
1	0	0
1	1	1

Out

Input A:

Input B:

Input C:

Input D:

Input E:

This symbol denotes a function which has not been enabled and is treated as a logic zero input.

Figure 6.37: Simulating Main Breaker Close Command using Virtual Input in ProLogic

ProLogic 2: This equation is used to reset the Main Breaker Status via ProLogic 3 (Opens Out 5).

**ProLogic 2 [Bkr Status Reset]**

Enabled

Name:

Pickup Delay:  s

Dropout Delay:  s

Target Enabled

AND		
0	0	0
0	1	0
1	0	0
1	1	1

Out

Input A:

Input B:

Input C:

Input D:

Input E:

This symbol denotes a function which has not been enabled and is treated as a logic zero input.

Figure 6.38: Breaker Status Reset using ProLogic (Ext. Input 3 via Output Contact 5)

ProLogic 3: This equation is set from ProLogic 1 (Main Breaker Close Command) OR ProLogic 9 (Main Breaker Reclose). (Note that ProLogic 9 is mapped to Out 14, so Out 14 is used to indirectly provide ProLogic 9 availability to ProLogic 1 through 8.) ProLogic 9 changes the Main Breaker Status contact (Out 5) and apply a trip signal via ProLogic 4. Reset occurs when ProLogic 2 (Breaker Status Reset) is activated.

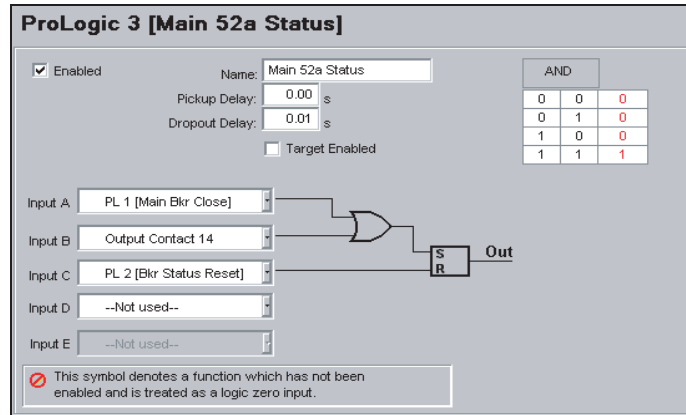

Figure 6.39: Main Breaker Status

ProLogic 4: This equation applies the External Trip (Closes Out 7), 10 seconds after the Breaker Status (ProLogic 3) goes high (i.e. Main Breaker Status = Closed).

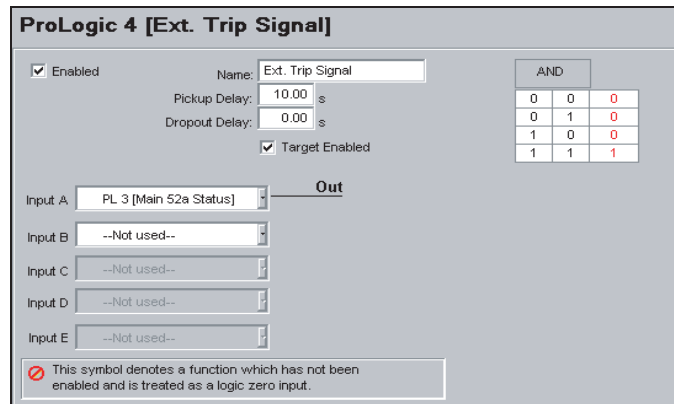

Figure 6.40: Using ProLogic to give Trip Command via External Input



ProLogic 5: This equation provides indication via the L-PRO HMI display, that the Recloser has locked out.

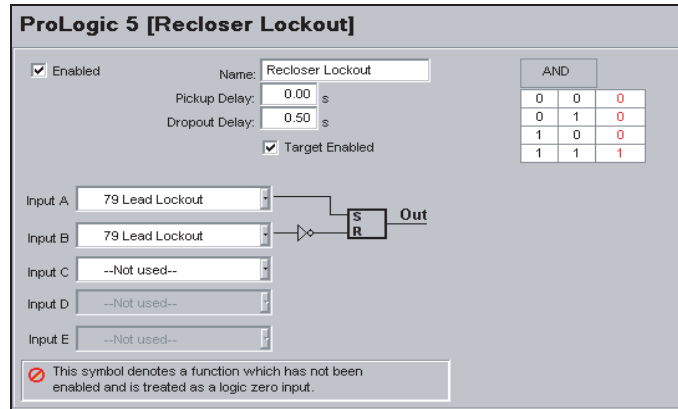

Figure 6.41: Recloser Lockout

ProLogic 6: This equation resets the 79 Lockout. It uses Virtual Input 1 “SCADA Reset 79” to simulate a SCADA Lockout Reset command. In this case, this is done by closing the Main Breaker Status (Out 5), then Auxiliary Breaker Status (Out 6) to simulate main and auxiliary breaker closed status. This latching function resets when the 79 Lead Lockout goes low.

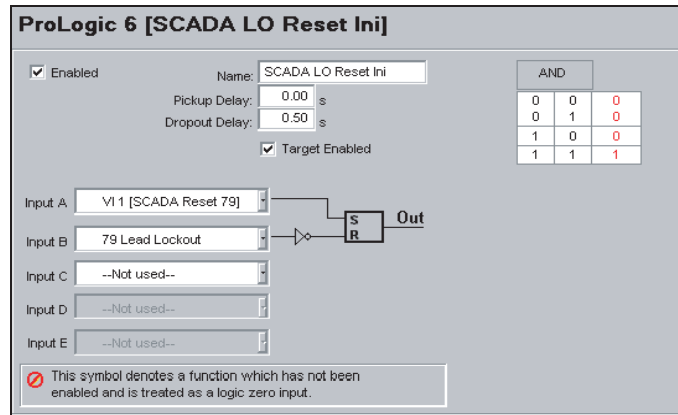

Figure 6.42: Using Virtual Input to simulate SCADA Recloser Lockout Reset

ProLogic 7: This equation is intended only for giving indication of when the 79 Lockout is reset.

This indication, along with ProLogic 6, proves the 79 Reset timer (TD).

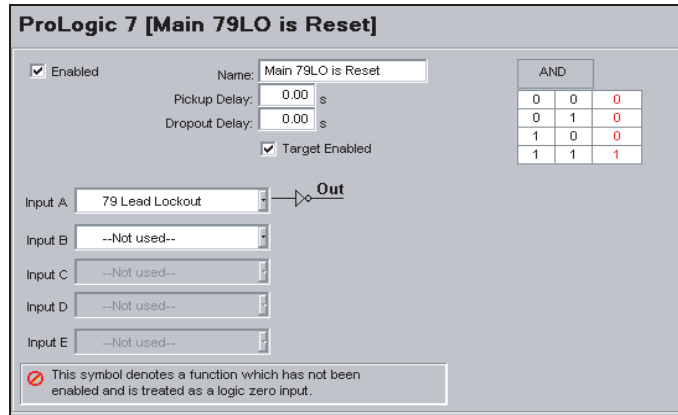

Figure 6.43: Main Recloser Lockout Reset Indication

ProLogic 8: This equation closes Out 6 to simulate auxiliary breaker closed status from SCADA breaker close command OR auxiliary recloser operation. This latching function resets when an external trip is received.

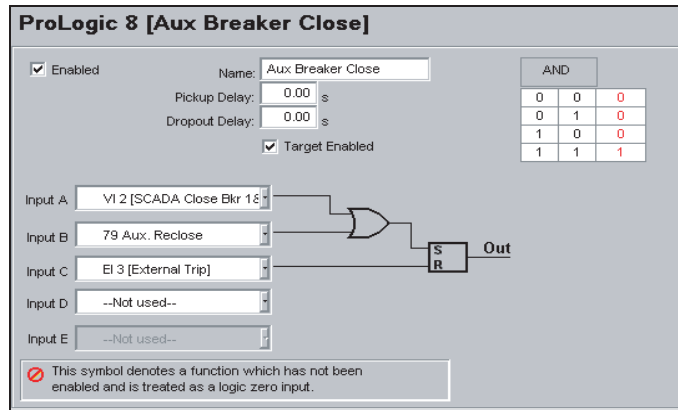

Figure 6.44: Auxiliary Breaker Close Command via Virtual Input

ProLogic 9: This equation closes Out 5 to simulate Main Breaker ‘a’ contact, and also closes Out 14 to provide feedback into Main Breaker Status ProLogic 3. This latching function resets when an external trip is received.

**ProLogic 9 [Main Bkr Reclose]**

Enabled

Name: Main Bkr Reclose

Pickup Delay: 0.00 s

Dropout Delay: 0.00 s

Target Enabled

AND		
0	0	0
0	1	0
1	0	0
1	1	1

Input A: 79 Main Reclose **Out**

Input B: --Not used--

Input C: --Not used--

Input D: --Not used--

Input E: --Not used--

 This symbol denotes a function which has not been enabled and is treated as a logic zero input.

Figure 6.45: Main Breaker Reclose

### 79 Reset Procedure (perform this before beginning the 79 Test)

- 1 In Terminal Mode Service level access *Utilities>Maintenance>Control Virtual Inputs*.
  - 2 Scroll to Virtual Input 2 (“SCADA LO Reset Ini”).
  - 3 Pulse On (This simulates a SCADA 79 Lockout Reset Command”).  
Observe L-PRO Target: “Init LO Reset VI: PL6”  
After 12 Seconds, Target: “Main LO is Reset: PL7”
- End of 79 Reset procedure.

**79 Test Procedure:**

- 1 Access *Utilities>Maintenance>Control Virtual Inputs*.
- 2 Scroll to Virtual Input 1 (“SCADA Close Bkr 1&2”).
- 3 Pulse On (This simulates a SCADA Breaker Close command.)

Observe L-PRO actions on the L-PRO HMI:

Main Breaker Close and Aux Breaker Close

After 10 Seconds: External Trip (Time delay of ProLogic4)

After 2 Seconds: Main Bkr Reclose (Shot 1, T1)

After 8 Seconds: Auxiliary Breaker Close (Shot 1, TF)

After 2 Seconds: External Trip (PL4 – TF)

After 4 Seconds: Main Bkr Reclose (Shot 2, T2)

After 8 Seconds: Aux Breaker Close (Shot 2, TF)

After 2 Seconds: External Trip (PL4 – TF)

After 6 Seconds: Main Bkr Reclose (Shot 3, T3)

After 8 Seconds: Aux Breaker Close (Shot 3, TF)

After 2 Seconds: External Trip (PL4 – TF)

After 8 Seconds: Main Bkr Reclose (Shot 4, T4)

After 8 Seconds: Aux Breaker Close (Shot 4, TF)

After 2 Seconds: External Trip (PL4 – TF)

After 1.3 Seconds: Recloser Lockout (1.0 seconds + Tp)

- 4 For detail of shot numbers, etc. observe the sequence of events by viewing: *Main Menu>Event Log* or by pressing the *View Logs* button of the L-PRO HMI. (Note: Targets need to be reset before you can view logs via HMI).

LPRO Unit ID: R00001	
Main Menu	User Access Level:SERVICE 2002Oct03 09:11
ID Settings Metering Records <b>Event Log</b> Utilities Access Quit	
TIME	EVENT
2002Oct03 09:10:11.394	Recloser Lockout : PL5
2002Oct03 09:10:11.394	79 Lead lockout: High
2002Oct03 09:10:10.102	252759 Sync Check:Armed (R)
2002Oct03 09:10:09.969	79 Initiated: High
2002Oct03 09:10:09.969	Bkr Status Reset : PL2
2002Oct03 09:10:09.969	External Trip Inpu: EI2
2002Oct03 09:10:09.962	Ext. Trip Signal : PL4
2002Oct03 09:10:08.002	Aux Bkr 'a' Closed: EI3
2002Oct03 09:10:07.996	79 Aux. Reclose:(shot 4) (R)
2002Oct03 09:10:07.996	Aux Breaker Close : PL8
2002Oct03 09:09:59.967	Main Bkr 'a' Close: EI1
2002Oct03 09:09:59.962	Main 52a Status : PL3
2002Oct03 09:09:59.960	79 Main Reclose:(shot 4) (R)
2002Oct03 09:09:59.960	Main Bkr Reclose : PL9
2002Oct03 09:09:51.971	252759 Sync Check:Armed (R)

F3 Quit, C-UP & C-DOWN move one line, U page up, D page down, T Top, B Bottom

Figure 6.46: Event Log Showing Reclose Sequence (HyperTerminal)

- 5 To perform this test again, reset the Lockout as per 79 Reset Procedure above, then repeat the 79 test procedure.

End of 79 test.

---

# 7 Installation

## Physical Mounting

### Standard 3U

The relay is 3 rack units or 5.25 inches high and approximately 12.25 inches deep. The standard relay is designed for a 19-inch rack. A complete mechanical drawing is shown, for details see “Mechanical Drawings” in Appendix G.

To install the relay you need the following:

- 19 inch rack
- 4 - #10 screws

### Optional 4U

The relay is 4 rack units or 7.0 inches high and approximately 12.25 inches deep. The relay is designed for a 19-inch rack. A complete mechanical drawing is shown, for details see “Mechanical Drawings” in Appendix G.

To install the relay you need the following:

- 19 inch rack
- 4 - #10 screws

## AC and DC Wiring

For details see “AC Schematic Drawings” in Appendix I and “DC Schematic Drawings” in Appendix J.

## Communication Wiring

### EIA-232

The relay’s three serial ports (Ports 1, 2 and 3) are configured as EIA RS-232 Data Communications Equipment (DCE) devices with female DB9 connectors. This allows them to be connected directly to a PC serial port with a standard straight-through male-to-female serial cable. For pin-out details see “Communication Port Details” on page 2-9.

An adapter is available for connecting an external modem to Port 2. For details, see “Modem Link - External” on page 2-3.

### RJ-45

The relay may have an optional internal modem or an optional internal 10BaseT Ethernet port. Connection to either of these is via the relay’s Port 5 RJ-45 receptacle. Labeling above the port will indicate which option, if any, has been installed.

### IRIG-B Wiring

The relay accepts both modulated and unmodulated IRIG-B standard time signals with or without the IEEE 1344 extensions. The IRIG-B connector on the back of the relay is BNC type.



---

# 8 Cyber Security

## System Access Control and Authorisation

Access to L-PRO is protected by login name and password. Each login name is associated with an Access Level. Section 3 “Terminal Mode” provides details on the Access Levels and login names.

### Password Complexity

Password maximum length is 22 characters. Password may contain:

- Lower case letters ( a – z )
- Upper case letters ( A – Z )
- Numeric characters ( 0 – 9 )
- Special characters as follows:

Table 8.1: Special Characters		
Character	ASCII Decimal	Description
!	033	Exclamation mark
"	034	Quotation mark
#	035	Number sign
\$	036	Dollar sign
%	037	Percent sign
&	038	Ampersand
'	039	Apostrophe
(	040	Left parenthesis
)	041	Right parenthesis
*	042	Asterisk
+	043	Plus sign
,	044	Comma
-	045	Hyphen-minus
.	046	Full stop
/	047	Slash (Solidus)
:	058	Colon
;	059	Semicolon
<	060	Less-than sign
=	061	Equal sign
>	062	Greater-than sign
?	063	Question mark

**Table 8.1: Special Characters**

@	064	At sign
[	091	Left Square Bracket
]	093	Right Square Bracket
^	094	Circumflex accent
_	095	Low line
	124	Vertical bar
{	123	Left Curly Bracket
}	125	Right Curly Bracket
~	126	Tilde

Special characters other than listed above may currently be used for passwords. However, only the listed characters are guaranteed to be supported in the future.

L-PRO does not enforce password complexity rules. However, password compliance to the following complexity rules can be verified, when password is being updated

- Minimum password length 8 characters.
- At least one upper case character.
- At least one lower case character.
- At least one numerical character.
- At least one special character.

### **Access Timeout**

User is automatically logged out after 60 minutes of inactivity.

### **Access Level Blocking**

L-PRO automatically blocks (locks out) Access Level for 5 minutes after 7 unsuccessful login attempts. Lock-out of one Access Level does not affect availability of the others.

### **Authorization by Access Level**

Each Access Level is assigned a set of functions authorized for it. The set of functions is pre-defined and cannot be changed. Six Access Levels are defined. Access Level list and set of functions associated with each level are described in section 3 “Terminal Mode”.



## Cyber Security Event Monitoring and Logging

L-PRO monitors activities of the logged in user. If user actions result in a change of IED critical resource, control or change of IED state, a Security Notification is generated. There are two types of Security Notification

- Security Events;
- Security Alarms.

Security Event is a Security Notification of an authorized activity, which has a limited effect on L-PRO protection functions.

Security Alarm is a Security Notification of an authorized or unauthorized activity, which may result in a loss of one or more protection functions or make unit unusable.

L-PRO differentiate the following types of Cyber Security activities.

Activity	Message ID	Description
Access to IED resources	ACCS	Access to the configuration, settings, records, files and control data
Authentication	AUTH	User authentication
Security Management	SECU	Access to IED Security data <ul style="list-style-type: none"> <li>• Passwords</li> <li>• Syslog Configuration</li> </ul>
System state change	SYST	IED system state has changed or change is imminent

Security Notifications are available via Cyber Security Notification messages. L-PRO provides Cyber Security Notification messages to an external (relative to L-PRO) Syslog server. Syslog server interface complies with RFC5424 (“The Syslog protocol”) and RFC5426 (“Transmission of Syslog messages over UDP”) standards.

Cyber Security Notification messages are issued in real-time and can be used for both logging and supervisory monitoring.

Syslog server settings are available in “Syslog Configuration” submenu (“Terminal Mode” on page 3-5 for details).

## Cyber Security Notification message format

Cyber Security Notification message (message) is a text line. Message example is shown below.

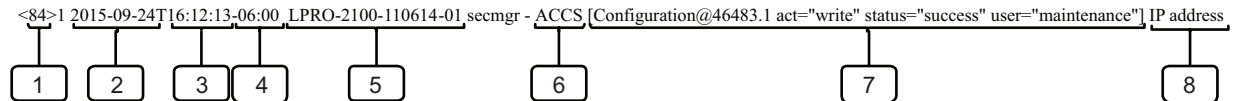

- 1 - message priority
- 2 - message date
- 3 - time of day
- 4 - time zone offset
- 5 - Host Name
- 6 - message ID
- 7 - message data
- 8 - optional description

### Message priority

Message priority defines message relative importance. The lower the priority value the more important (critical) is the message. The list of message priorities is as follows.

Table 8.3: Message Priority List	
Message Priority	Severity (RFC 5424)
<b>Security Alarms</b>	
32	Emergency
33	Alert
34	Error
<b>Security Events</b>	
81	Alert
82	Critical
83	Error
84	Warning
85	Notice

### Message Date

Message date has format YYYY-MM-DD.

**Time of Day** Time of day has format HH-MM-SS.

**Time Zone Offset** Time zone offset has format +/- HH-MM. If time zone offset equals 0 (UTC), then “Z” notation is used instead as shown in the example below.

```
<84>1 2015-09-24T16:12:13Z 192.168.103.10 secmgr - ACCS [Configuration@46483.1 act="write" status="success" user="maintenance"] IP address
```

**Host Name** ‘Host Name’ field identifies IED issuing the Syslog Notification message. The field can be configured to contain one of the following values

- Unit IP Address;
- Unit Serial Number;
- Unit ID.

Selection of the ‘Host Name’ field value is available in the “Syslog Configuration” menu.

Figure 8.1, Figure 8.2 and Figure 8.3 below illustrate relationship between Syslog Configuration menu selection and ‘Host Name’ field.

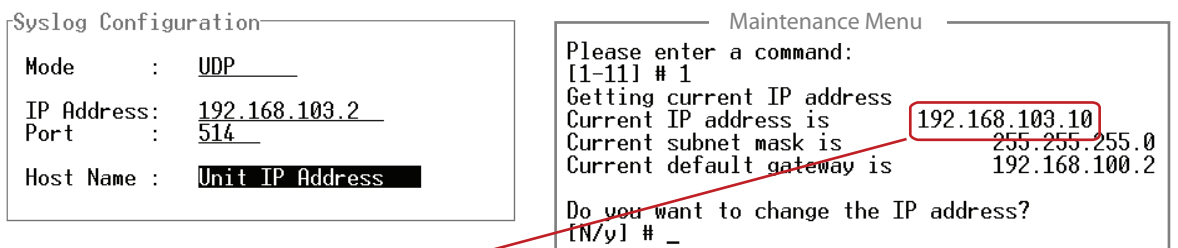

```
<84>1 2015-09-24T16:12:13-06:00 192.168.103.10 secmgr - ACCS [Configuration@46483.1 act="write" status="success" user="maintenance"] IP address
```

Figure 8.1: Unit IP Address as “Host Name”

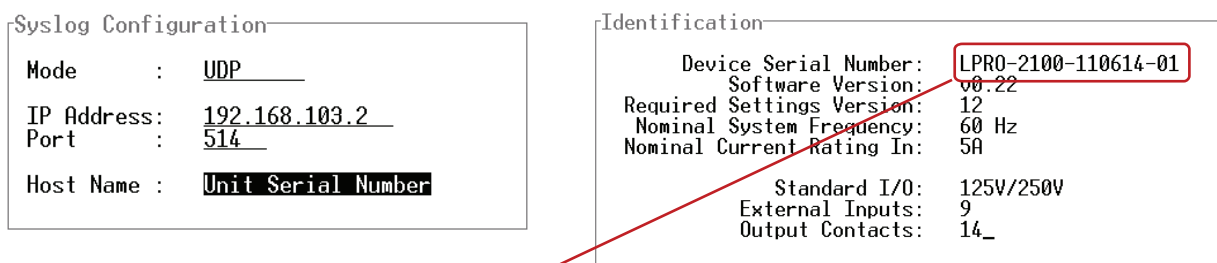

```
<84>1 2015-09-24T16:12:13-06:00 LPRO-2100-110614-01 secmgr - ACCS [Configuration@46483.1 act="write" status="success" user="maintenance"] IP address
```

Figure 8.2: Unit Serial Number as “Host Name”

```

Syslog Configuration
Mode      : UDP
IP Address: 192.168.103.2
Port      : 514
Host Name : Unit ID

L-PRO Unit ID: Line_XYZ_IED1
Main Menu/Settings User Access Level: VIEW      2015Nov25 22:44
prev menu Active Group Settings Load from Offliner Retrieve to Offliner

L-PRO Settings
>Identification
  L-PRO System Parameters
  Line Parameters (common)
  Setting Group 1..
  Setting Group 2..
  Setting Group 3..
  Setting Group 4..
  Setting Group 5..
  Setting Group 6..
  Setting Group 7..
  Setting Group 8..
  Recording

  Identification
  >Relay
  Settings Identification
    Settings Version: 12
    L-PRO Serial Number: LPRO-2100-110614-01
    Setting Name: Default Settings
    Date Created/Modified: 15 Nov 25 20:00:58
    Unit ID: Line_XYZ_IED1
    Line: 0245
  
```

<84>1 2015-09-24T16:12:13-06:00 Line\_XYZ\_IED1 secmgr - ACCS [Configuration@46483.1 act="write" status="success" user="maintenance"] IP address

Figure 8.3: Unit ID as “Host Name”

### Message Data

Message data provides Security Notification details. It starts with the message data ID that uniquely identifies the purpose of data, followed by parameter-value pairs. In the above examples on Figure 8.1 through Figure 8.3, message data ID is “Configuration@46483.1”. The list of message data IDs is as follows.

Table 8.4: Message Data ID List		
Message Data ID	Message ID	Description
Login@46483.1	AUTH	User login
Logout@46483.1	AUTH	User logout
Accounts@46483.1	SECU	Access to IED password settings
SyslogConfig@46483.1	SECU	Access to IED Syslog Configuration
Configuration@46483.1	ACCS	Access to IED configuration data
Settings@46483.1	ACCS	Access to IED settings data
Firmware@46483.1	ACCS	IED firmware update information
Records@46483.1	ACCS	Access to/Control of IED Records
EventLog@46483.1	ACCS	Access to IED Event Log
VirtualInputs@46483.1	ACCS	IED Virtual Inputs control
OutputContacts@46483.1	ACCS	IED Output Contacts control
TimeSettings@46483.1	ACCS	IED Time Settings change
Calibration@46483.1	ACCS	IED Calibration Settings change
SysArchive@46483.1	ACCS	Access to IED System Archive
Event@46483.1	SYST	IED System Event

---

## IP Ports and Services

Table 8.5: IP Ports and Services describes IP ports and services available within L-PRO.

<b>Table 8.5: IP Ports and Services</b>				
<b>Port</b>	<b>Control</b>	<b>Protocol</b>	<b>Service</b>	<b>Comments</b>
23	Always enabled	TCP	Telnet	User interface access
20000	Enabled/disabled	TCP/UDP	DNP3	DNP3 communication. Port number is configurable. Port is disabled, if DNP3 SCADA communication over Ethernet is disabled
514	Enabled/disabled	UDP	Syslog	Syslog server communication. Port number is configurable.

## IEEE 1686 Table of Compliance

Clause Number	Clause/sub Clause Title	Status	Comment
5	IED cyber security features	Acknowledge	
5.1	Electronic access control	Exception	
5.1.1	IED access control overview	Comply	
5.1.2	Password defeat mechanisms	Comply	
5.1.3	Number of individual users	Exception	Number of individual users is 6
5.1.4	Password construction	Exception	Password complexity rules are not enforced, but can be validated
5.1.5	IED access control	Exception	
5.1.5.1	Authorization levels by password	Exception	Authorization level is defined by login name
5.1.5.2	Authorization using role-based access control (RBAC)	Exception	Authorization using RBAC is not supported
5.1.6	IED main security functions	Exception	
5.1.6 a)	View data	Comply	
5.1.6 b)	View configuration settings	Comply	
5.1.6 c)	Force values	Comply	
5.1.6 d)	Configuration change	Comply	
5.1.6 e)	Firmware change	Comply	
5.1.6 f)	ID/password or RBAC management	Comply	Feature not offered in this product
5.1.6 g)	Audit trail	Exception	Audit trail is not supported
5.1.7	Password display	Exception	Passwords are displayed when user logs in
5.1.8	Access timeout	Exception	Access timeout period is 60 minutes and cannot be changed
5.2	Audit trail	Exception	Audit trail is not supported. Cyber Security Notification to an external Syslog(RFC 5424) server is provided instead
5.2.1	Audit trail background	Exception	Not supported
5.2.2	Storage capability	Exception	Not supported
5.2.3	Storage record	Exception	
5.2.3 a)	Event record number	Exception	Not supported
5.2.3 b)	Time and date	Comply	
5.2.3 c)	User identification	Comply	
5.2.3 d)	Event type	Comply	
5.2.4	Audit trail event types	Exception	

5.2.4 a)	Log in	Comply	
5.2.4 b)	Manual log out	Comply	
5.2.4 c)	Timed log out	Comply	
5.2.4 d)	Value forcing	Comply	
5.2.4 e)	Configuration access	Comply	
5.2.4 f)	Configuration change	Comply	
5.2.4 g)	Firmware change	Comply	
5.2.4 h)	ID/password creation or modification	Comply	
5.2.4 i)	ID/Password deletion	Comply	Feature not offered in this product
5.2.4 j)	Audit log access	Comply	Feature not offered in this product
5.2.4 k)	Time/date change	Comply	
5.2.4 l)	Alarm incident	Exception	Not all alarm incidents are supported
5.3	Supervisory monitoring and control	Exception	
5.3.1	Overview of supervisory monitoring and control	Comply	Real-time Cyber Security Notification (Events and Alarms) is available via Syslog protocol in compliance with RFC 5424 and RFC 5426 standards
5.3.2	Events	Comply	
5.3.3	Alarms	Exception	
5.3.3 a)	Unsuccessful login attempt	Comply	
5.3.3 b)	Reboot:	Comply	
5.3.3 c)	Attempted use of unauthorized configuration software	Exception	Not supported
5.3.3 d)	Invalid configuration or firmware download	Comply	
5.3.3 e)	Unauthorized configuration or firmware file	Exception	Not supported
5.3.3 f)	Time signal out of tolerance	Exception	Not supported
5.3.3 g)	Invalid field hardware changes	Comply	Feature not offered in this product
5.3.4	Alarm point change detect	Comply	
5.3.5	Event and alarm grouping	Comply	Event and Alarm grouping is predefined. Event groups: <ul style="list-style-type: none"> <li>• Notice</li> <li>• Warning</li> <li>• Error</li> <li>• Critical</li> <li>• Alert</li> </ul> Alarm groups: <ul style="list-style-type: none"> <li>• Error</li> <li>• Alert</li> <li>• Emergency</li> </ul>
5.3.6	Supervisory permissive control	Exception	Not supported
5.4	IED cyber security features	Exception	
5.4.1	IED functionality compromise	Acknowledge	

5.4.2	Specific cryptographic features	Exception	
5.4.2 a)	Webserver functionality	Comply	Feature not offered in this product
5.4.2 b)	File transfer functionality	Exception	Not supported
5.4.2 c)	Text-oriented communication facilities	Exception	Not supported
5.4.2 d)	Single Network Management Protocol (SNMP)	Comply	Feature not offered in this product
5.4.2 e)	Network time synchronization	Comply	Feature not offered in this product
5.4.2 f)	Secure tunnel functionality	Exception	Not supported
5.4.3	Cryptographic techniques	Exception	Not supported
5.4.4	Encrypting serial communications	Exception	Not supported
5.4.5	Protocol-specific security features	Comply	
5.5	IED configuration software	Acknowledge	
5.5.1	Authentication	Exception	Not supported
5.5.2	Digital signature	Exception	Not supported
5.5.3	ID/password control	Exception	Not supported
5.5.4	ID/password controlled features	Exception	Not supported
5.5.4.1	View configuration data	Exception	Not supported
5.5.4.2	Change configuration data	Exception	Not supported
5.6	Communications port access	Exception	Communication port access control is limited to DNP3
5.7	Firmware quality assurance	Comply	



# Appendix A IED Specifications

<b>L-PRO Model 2100 Specifications</b>		
<b>Item</b>	<b>Quantity/Specs</b>	<b>Note</b>
<b>General:</b>		
Nominal Frequency	50 or 60 Hz	
Operate Time	1.0 to 1.3 cycles at 80% reach	Including output relay operation
Sampling Rate	96 samples/cycle	Records up to 25th harmonic
Power Supply	Nominal Range: 48 to 250 Vdc, 120 Vac, 50/60 Hz Full Operating Range: 40 to 300 Vdc	
Memory	Settings and records are stored in non-volatile memory	Records are stored in a circular buffer
<b>Protection Functions:</b>		
IEEE Dev. 21P-1, 2, 3, 4, 21N-1, 2, 3, 4, 27, 50BF, 50LS, 50/51/67, 50N/51N/67, 46/50//51/67, 59, 60, 68, 79, Sync Check, 81, Dead Line Pickup, Weak Infeed, Pro-Logic, Group Logic and Virtual Inputs	Line protection takes in up to 6 voltages and 6 currents Extra 6 currents used for recording and ProLogic input	Suitable for ring bus configurations
<b>Recording:</b>		
Fault	96 s/c oscillography of all analog and external input channels Capacity: up to 15 x 2 second records	Viewing software provides waveform, symmetrical components and harmonic analysis
Dynamic Swing	1 s/c phasor measurements of line positive sequence V and I plus frequency Capacity: up to 15 x 3 minute records	
Events	250 events	Circular event log
A/D Resolution	13 bits, 8192 counts full scale.	
<b>Input &amp; Output:</b>		
Analog Input Channels	18 (6 line currents, 3 line and 3 bus voltages, plus 6 currents for bus monitoring)	Rating: In = 5 A or 1 A, Vn = 69 V Continuous: 3x In, 2x Vn One Second: 20x In without distortion One Minute: 3x Vn, once per hour
Sampling Resolution	12 bits plus sign, amplitude measurement accuracy: $\pm 0.5\%$ for 54 to 66 Hz	
Burden	AC input voltage: < 0.15 VA @ 67 V, ac Input current: $\leq 0.50$ VA @ 5 A	
Analog Input Sampling	Sample rate: 96 samples/cycle for recording, 8x/cycle for protection	
External Inputs	9 isolated inputs (3U chassis) 20 isolated inputs (4U chassis)	Optional 48 to 125 or 125 to 250 Vdc nominal, externally wetted

<b>L-PRO Model 2100 Specifications</b>		
Burden	Burden resistance: > 10 k ohms	
Isolation	Internal optical isolation	
Sample Rate	1 ms resolution	
External Input Turn-on Voltage	48 Vdc range = 27 to 40 Vdc 125 Vdc = 75 to 100 Vdc 250 Vdc = 150 to 200 Vdc	Specified voltages are over full ambient temperature range.
Output Relays (contacts)	14 programmable outputs (3U chassis) 21 programmable outputs (4U chassis)	14 or 21 relay trip, 1 relay inoperative Make: 30 A as per IEEE C37.90 Carry: 8 A Break: 0.9 A at 125 Vdc 0.35 A at 250 Vdc
<b>Interface &amp; Communication:</b>		
Front Display	2 lines x 24 characters, fluorescent	Exceptional visibility in all ambient light conditions
Front Panel Indicators	6 LEDs	Target, Relay Functional, IRIG-B Functional, Service Required, Test Mode, Alarm
Serial User Interface	Front and rear RS-232 ports to 57.6 K baud	Rear port can support an external modem
Internal Modem	33.6 Kbps, V.32 bis	Optional internal modem
Network	10BaseT Ethernet port	Optional Ethernet card
SCADA Interface	DNP3 (RS-232 or Ethernet) or Modbus (RS-232)	Rear port
Time Sync	IRIG-B, BNC connector	Modulated or unmodulated, auto-detect
Self Checking/Relay Inoperative	1 contact	Closed when relay inoperative
Terminal User Interface	VT100 terminal emulation	Accessible via serial, modem or network interface
<b>Environmental:</b>		
Ambient Temperature Range	-40°C to 85°C	IEC 60068-2-1/IEC 60068-2-2
Humidity	Up to 95% without condensation	IEC 60068-2-30
Insulation Test (Hi-Pot)	Power supply, analog inputs, external inputs, output contacts – 1.5 kV, 50/60 Hz, 1 minute.	IEC 60255-5
Electrical Fast Transient		ANSI/IEEE C37.90.1 - 1989
Oscillatory Transient		ANSI/IEEE C37.90.1 - 1989
RFI Susceptibility		ANSI/IEEE C37.90.2, IEC 255-22-3
Shock and Bump		IEC 60255-21-2 Class 1
Sinusoidal Vibration	10 Hz to 150 Hz, 0.15 mm or 20 m/s <sup>2</sup> , 10 sweep cycles	IEC 60068-2-6
<b>Physical:</b>		

<b>L-PRO Model 2100 Specifications</b>		
Weight	11.1 kg (3U chassis) 14.5 kg (4U chassis)	24.47 lbs (3U chassis) 32.0 lbs (4U chassis)
Dimensions	13.3 cm (3U chassis) 17.7 cm (4U chassis)	5.25" (3U chassis) 7" (4U chassis)
	48.3 cm rack mount	19" rack mount
	30.5 cm deep	12" deep
<b>Time Synchronization and Accuracy</b>		
External Time Source	Synchronized using IRIG-B input (modulated or unmodulated) auto detect	Free Running Accuracy: In the absence of an external time source, the relay maintains time with a maximum $\pm 15$ minutes drift per year over the full operating temperature range, and maximum $\pm 90$ seconds drift per year at a constant temperature of 25°C. The relay can detect loss or re-establishment of external time source and automatically switch between internal and external time.
Synchronization Accuracy	Sampling clocks synchronized with the time source (internal or external)	
<b>Overall L-PRO Accuracies</b>		
Current	$\pm 2.5\%$ of inputs from 0.1 to 1.0 x nominal current ( $I_n$ )	
	1.0% of inputs from 1.0 to 20.0 x nominal current ( $I_n$ )	
Voltage	1.0% of inputs from 0.01 to 2.00 x nominal voltage ( $V_n$ )	
Impedance	$\pm 5.0\%$ or 5 m $\Omega$ of set value from 0.05 to 66.00 ohms secondary (0.25 to 330.00 ohms secondary, 1 A nominal)	
Directional Phase Angle	$\pm 2.0^\circ$ of set value of Positive Sequence Line Angle value from 25.0° to 89.0°	
Frequency Elements	$\pm 0.001$ Hz (fixed level)	
	$\pm 0.05$ Hz (df/dt)	
Sync Check Elements	$\pm 0.2$ degrees	
Timers	$\pm 2.5$ ms of set value plus 1.00 to 1.50 cycles of inherent delay	
Inverse Overcurrent Timers	$\pm 2.5\%$ or $\pm 1$ cycle of selected curve	
Definite Overcurrent Timers	$\pm 2.5\%$ or $\pm 1$ cycle non-directional	
	$\pm 2.5\%$ or $\pm 1.5$ cycle directional	
Frequency Timer	$\pm 2.5\%$ of set value plus 1.25 cycles to 1.75 cycles of inherent delay (fixed level) at 2x pickup, error <40 ms (df/dt) at 0.1 Hz/s above pickup, error <100 ms	
Burden	AC Voltage Inputs, < 0.15 VA @ 69 volts	
	AC Current Inputs, $\leq 0.5$ VA @ 5 A	

## Distance Element Operating Time Curves at Nominal Frequency

Figure A.1: on page 4, Figure A.3: on page 5 and Figure A.5: on page 6 show operating times for the L-PRO Relay distance elements.

The diagrams show operating times at each test point including output contact operate time.

Faults were applied at a location representing a percentage of the Zone 1 relay reach setting.

Tests were performed for source impedance ratios (SIR) of 0.1, 1.0, 10.0, and 30.0.

No pre-fault load current or fault resistance was included. Operating times are the same for both 50 Hz and 60 Hz.

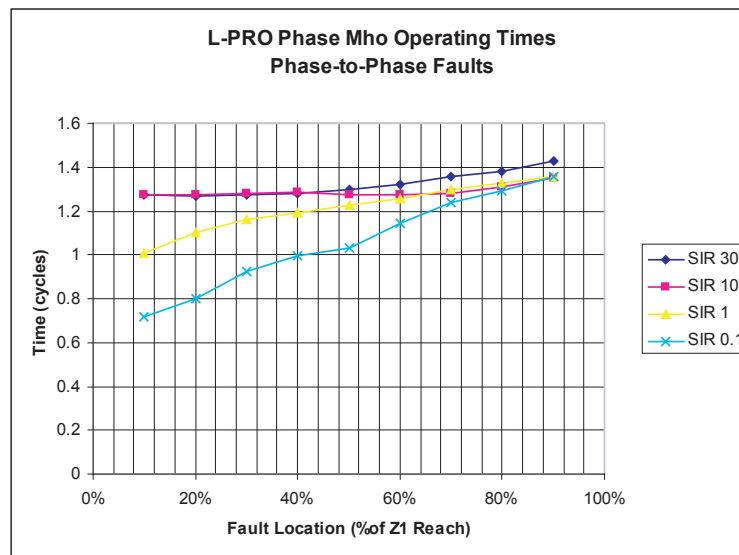

Figure A.1: L-PRO Phase Mho Operating Times Phase-to-Phase Faults (with CCVT setting disabled)

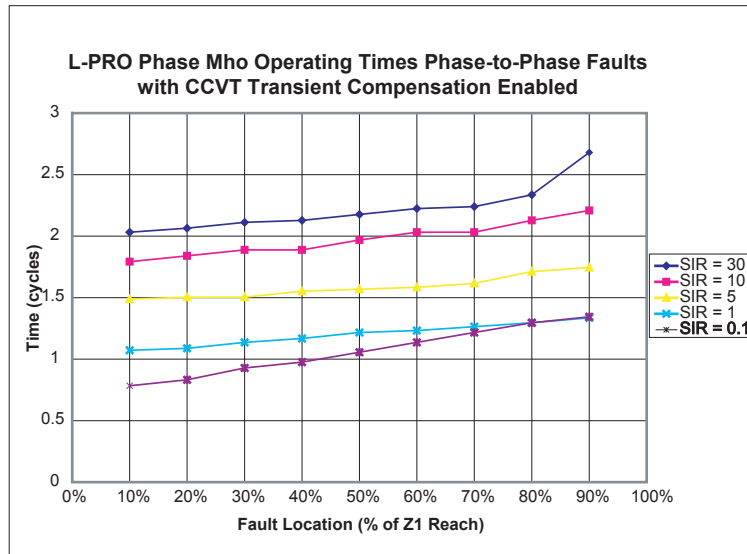

Figure A.2: L-PRO Phase Mho Operating Times Phase-to-Phase Faults (with CCVT setting enabled)

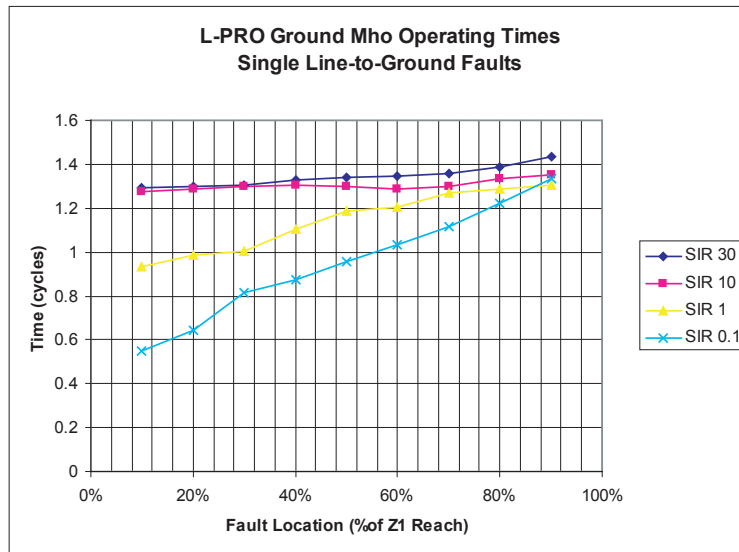

Figure A.3: L-PRO Ground Mho Operating Times Single Line-to-Ground Faults (with CCVT setting disabled)

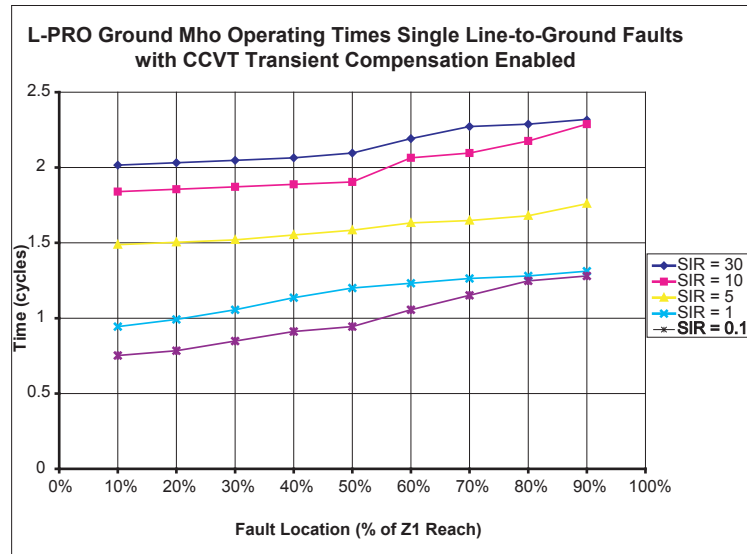

Figure A.4: L-PRO Ground Mho Operating Times Single Line -to-Ground Faults (with CCVT setting enabled)

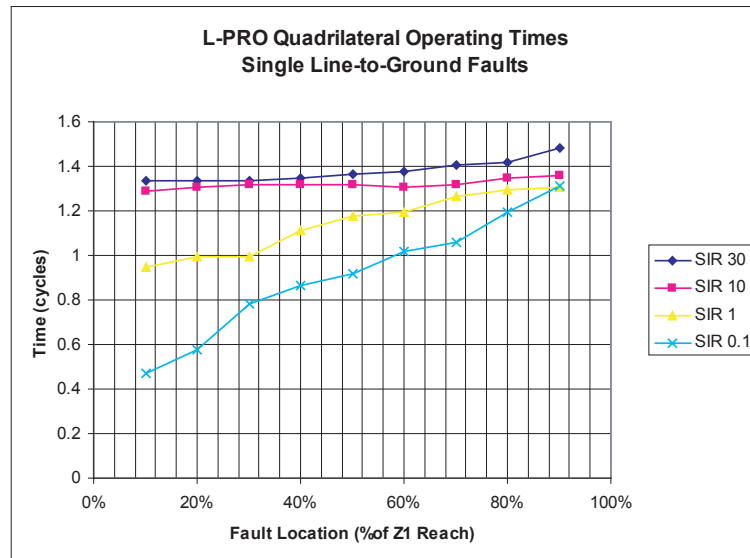

Figure A.5: L-PRO Quadrilateral Operating Times Single Line-to-Ground Faults (with CCVT setting disabled)

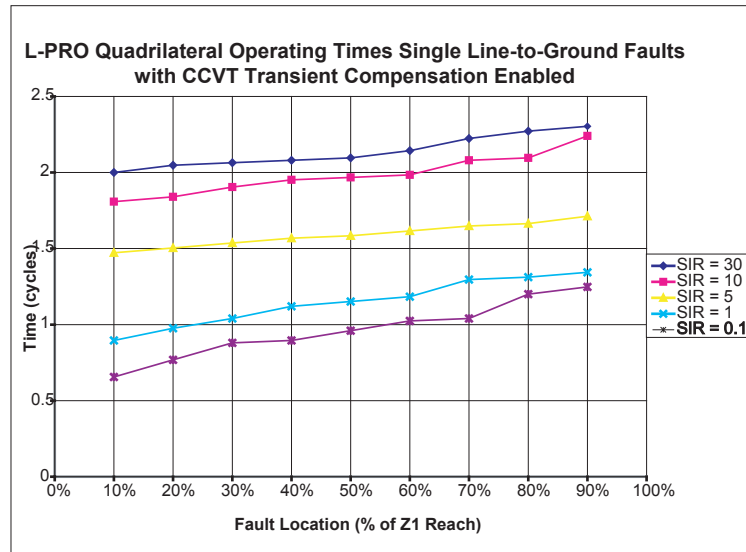

Figure A.6: L-PRO Quadrilateral Operating Times Single Line-to-Ground Faults (with CCVT setting enabled)

# Frequency Element Operating Time Curves

Figure A.7: Time delay Error at .2 Seconds, Figure A.8: Time Delay Error at 1 Second and Figure A.9: Time Delay Error at 10 Seconds show operating times for the L-PRO frequency rate of change elements at different time delay settings and rate of change settings.

The diagrams show operating times at each test point including output contact operate time. Operating times are the same for both 50 Hz and 60 Hz.

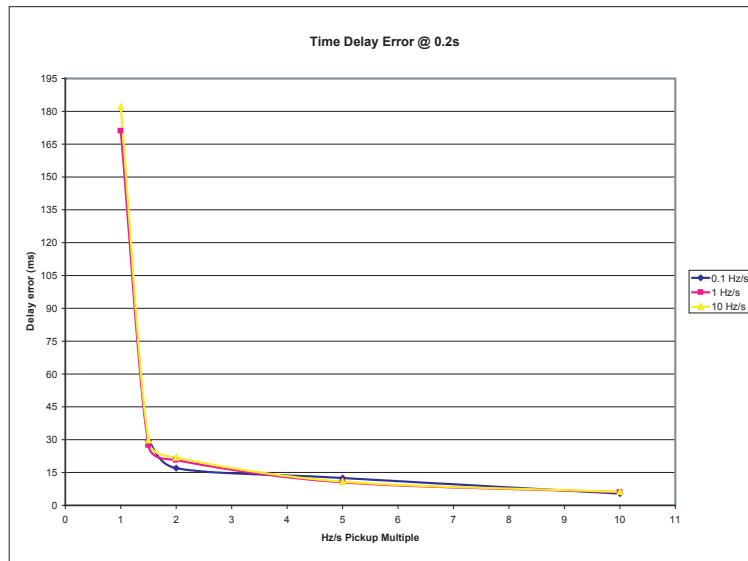

Figure A.7: Time delay Error at .2 Seconds

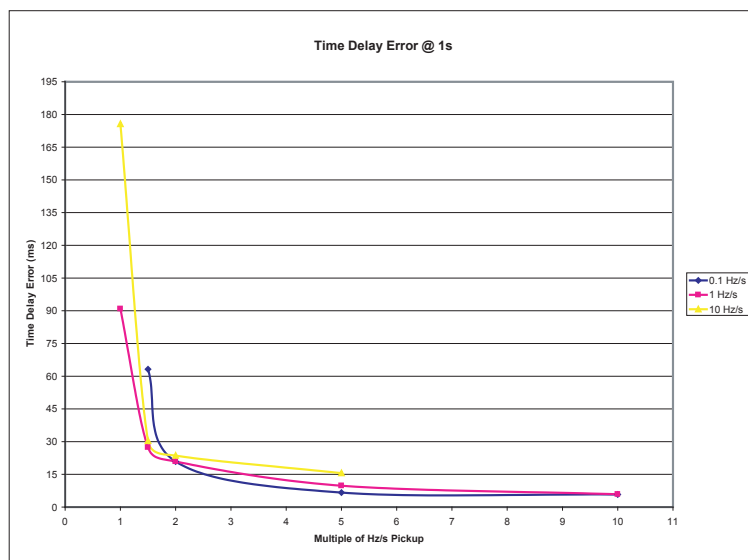

Figure A.8: Time Delay Error at 1 Second



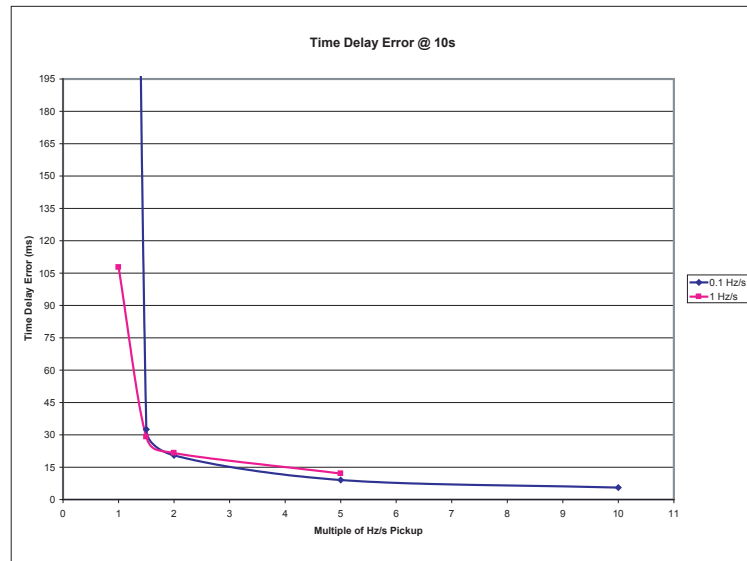

Figure A.9: Time Delay Error at 10 Seconds

## External Input Pickup Filter

To guarantee security from spurious voltage pulses an external input pickup filter setting has been introduced. This setting is made in terminal mode under, *Utilities>Setup>External Inputs*. The setting is an integer number representing the number of samples in a packet of 12 that must be recognized by the DSP as high before an External Input status is changed from low to high. This will affect the pulse width required for the External Inputs to be detected. Below is a table describing the pulse widths for possible and definite defection for each setting.

Pickup Filter Count	Input Pulse Width required for EI to be possibly detected	Input Pulse Width required for EI to be definitely detected
4	0.694 ms	1.215 ms
5	0.868 ms	1.563 ms
6	1.042 ms	1.909 ms
7	1.215 ms	2.257 ms
8	1.389 ms	2.604 ms
9	1.563 ms	2.951 ms
10	1.736 ms	3.299 ms
11	1.909 ms	3.645 ms
12	2.083 ms	3.993 ms

For a setting of 6, it will take between 1.042 and 1.909 ms for an External Input to be declared as high. The default setting is 4, which was the number that was used in the L-PRO prior to Version 10.

# Appendix B IED Settings and Ranges

## Settings and Ranges

When a setting has been completed in *Offliner* Settings software, it can be printed along with the ranges available for these settings. This is a view only option; to change the settings you must go back into the particular setting that you wish to change. The summary is a quick way to view all the settings in a compact form.

The top part of the settings summary contains all the information from the Relay Identification screen.

The setting summary provides a list of all the current and voltage analog input quantity names used for protection and recording. External Inputs and Output contact names are also identified on this summary.

L-PRO Settings Summary - Setting Group 1 [Setting Group 1]			
Name	Symbol/Value	Unit	Range
Relay Identification			
Settings Version	10		
Ignore Serial Number	No		
Serial Number	LPRO-2100-991001-01		
Unit ID	UnitID		
Setting Name	Default Settings		
Nominal CT Secondary Current	5 A		
Nominal System Frequency	60 Hz		
Standard I/O	9 External Inputs, 14 Output Contacts		
Optional I/O	Not Installed		
Comments	Comments		
Date Created-Modified	2000-09-06 16:21:22		
Station Name	Station Name		
Station Number	1		
Location	Location		
Line	D245		
Analog Input Names			
LVA	Main Voltage A		
LVB	Main Voltage B		
LVC	Main Voltage C		
LIA	Main Line Current A		
LIB	Main Line Current B		
LIC	Main Line Current C		
IA2	Aux. Line Current A		
IB2	Aux. Line Current B		
IC2	Aux. Line Current C		

L-PRO Settings Summary - Setting Group 1 [Setting Group 1]			
IA3	Current 3 A		
IB3	Current 3 B		
IC3	Current 3 C		
IA4	Current 4 A		
IB4	Current 4 B		
IC4	Current 4 C		
BVA	Aux. Voltage A		
BVB	Aux. Voltage B		
BVC	Aux. Voltage C		
External Input Names			
1	Spare 1		
2	Spare 2		
3	Spare 3		
4	Spare 4		
5	Spare 5		
6	Spare 6		
7	Spare 7		
8	Spare 8		
9	Spare 9		
Output Contact Names			
Output 1	Spare 1		
Output 2	Spare 2		
Output 3	Spare 3		
Output 4	Spare 4		
Output 5	Spare 5		
Output 6	Spare 6		
Output 7	Spare 7		
Output 8	Spare 8		
Output 9	Spare 9		
Output 10	Spare 10		
Output 11	Spare 11		
Output 12	Spare 12		
Output 13	Spare 13		
Output 14	Spare 14		
Output Contact Dropout Timers			
Output1 ( Spare 1 )	0.10	s	0.00 to 1.00
Output2 ( Spare 2 )	0.10	s	0.00 to 1.00
Output3 ( Spare 3 )	0.10	s	0.00 to 1.00
Output4 ( Spare 4 )	0.10	s	0.00 to 1.00

L-PRO Settings Summary - Setting Group 1 [Setting Group 1]			
Output5 ( Spare 5 )	0.10	s	0.00 to 1.00
Output6 ( Spare 6 )	0.10	s	0.00 to 1.00
Output7 ( Spare 7 )	0.10	s	0.00 to 1.00
Output8 ( Spare 8 )	0.10	s	0.00 to 1.00
Output9 ( Spare 9 )	0.10	s	0.00 to 1.00
Output10 ( Spare 10 )	0.10	s	0.00 to 1.00
Output11 ( Spare 11 )	0.10	s	0.00 to 1.00
Output12 ( Spare 12 )	0.10	s	0.00 to 1.00
Output13 ( Spare 13 )	0.10	s	0.00 to 1.00
Output14 ( Spare 14 )	0.10	s	0.00 to 1.00
Virtual Input Names			
VI 1	Virtual Input 1		
VI 2	Virtual Input 2		
VI 3	Virtual Input 3		
VI 4	Virtual Input 4		
VI 5	Virtual Input 5		
VI 6	Virtual Input 6		
VI 7	Virtual Input 7		
VI 8	Virtual Input 8		
VI 9	Virtual Input 9		
VI 10	Virtual Input 10		
VI 11	Virtual Input 11		
VI 12	Virtual Input 12		
VI 13	Virtual Input 13		
VI 14	Virtual Input 14		
VI 15	Virtual Input 15		
VI 16	Virtual Input 16		
VI 17	Virtual Input 17		
VI 18	Virtual Input 18		
VI 19	Virtual Input 19		
VI 20	Virtual Input 20		
VI 21	Virtual Input 21		
VI 22	Virtual Input 22		
VI 23	Virtual Input 23		
VI 24	Virtual Input 24		
VI 25	Virtual Input 25		
VI 26	Virtual Input 26		
VI 27	Virtual Input 27		
VI 28	Virtual Input 28		

L-PRO Settings Summary - Setting Group 1 [Setting Group 1]			
VI 29	Virtual Input 29		
VI 30	Virtual Input 30		
Setting Group Names			
Setting Group 1	Setting Group 1		
Setting Group 2	Setting Group 2		
Setting Group 3	Setting Group 3		
Setting Group 4	Setting Group 4		
Setting Group 5	Setting Group 5		
Setting Group 6	Setting Group 6		
Setting Group 7	Setting Group 7		
Setting Group 8	Setting Group 8		
System Parameters			
Base MVA	100.00	MVA	1.00 to 1000.00
Phase Rotation	ABC		
Aux Voltage Input	Three Phase		
Target Latching	Enabled		
Fault Location Display	Enabled		
Fault Location Initiated by 21 Alarm	Disabled		
Ring Bus Configuration (Aux CT Line Input)	Enabled		
Main/Auxiliary CT Turns Ratio	240.00	:1 (Protection & Recording)	1.00 to 10000.00
CCVT Transient Compensation on All 21 Devices	Disabled		
Current Input #3 CT Ratio	400.00	:1 (Recording & ProLogic Input)	1.00 to 10000.00
Current Input #4 CT Ratio	500.00	:1 (Recording & ProLogic Input)	1.00 to 10000.00
Main PT Turns Ratio	2000.00	:1 (Protection & Recording)	1.00 to 20000.00
Auxiliary PT Turns Ratio	2000.00	:1 (Protection & Recording)	1.00 to 20000.00
Line to Line Voltage	230.00	kV	1.00 to 1000.00
Distance Unit Selection	km		
Record Length			
Fault Record Length	0.5	s	0.2 to 2.0
Swing Rod. Length	120	s	60 to 120
Event Auto Save	Disabled		
Setting Group 1 [Setting Group 1]			
Setting Group Comments:			
Line Parameters			
Line Length	200.00	km	0.50 to 2000.00
Positive Sequence Impedance (Z1)	14.40	ohm	0.05 to 66.00

L-PRO Settings Summary - Setting Group 1 [Setting Group 1]			
Positive Sequence Angle (Z1)	80.0	deg	45.0 to 89.0
Zero Sequence Impedance (Z0)	36.00	ohm	0.05 to 300.00
Zero Sequence Angle (Z0)	70.0	deg	45.0 to 89.0
K0 Override	Disabled		
K0 Magnitude	0.51	-	0.10 to 2.00
K0 Angle	-16.5	deg	-25.0 to 25.0
Scheme Selector			
Scheme Selection	POTT		
Communication Receiver1	EI 1 [Spare 1]		
Communication Receiver2	<disabled>		
Scheme Send Pickup Delay (TL3)	0.100	s	0.000 to 1.000
Scheme Send Dropout Delay (TD3)	0.200	s	0.000 to 1.000
POTT Current Reversal Pickup Delay (TL1)	0.300	s	0.000 to 0.500
POTT Current Reversal Dropout Delay (TD1)	0.400	s	0.000 to 0.500
DCB Scheme Zone 2 Pickup Delay (TL2)	0.500	s	0.005 to 0.500
DCB Scheme Receiver Dropout Delay (TD2)	0.500	s	0.000 to 0.500
50N-67F - Overcurrent Carrier Trip			
Action	Disabled		
Direction	Forward		
3I0 Pickup	1.0	A	0.2 to 50.0
Pickup Delay	0.020	s	0.005 to 1.000
50N-67R - Overcurrent Carrier Block			
Action	Disabled		
Direction	Reverse		
3I0 Pickup	1.0	A	0.2 to 50.0
Pickup Delay	0.020	s	0.005 to 1.000
52 - Breaker Status			
Main Breaker	EI 3 [Spare 3]		
Aux. Breaker	EI 2 [Spare 2]		
Protection Summary			
21P, Zone 1	Enabled		
21P, Zone 2	Enabled		
21P, Zone 3	Enabled		
21P, Zone 4	Enabled		
21N, Zone 1	Enabled		
21N, Zone 2	Enabled		
21N, Zone 3	Enabled		

L-PRO Settings Summary - Setting Group 1 [Setting Group 1]			
21N, Zone 4	Enabled		
68	Off		
Dead Line Pickup	Enabled		
Weak Infeed	Enabled		
25 Sync Check	Enabled		
Dead Main Live Aux (DMLA)	Enabled		
Live Main Dead Aux (LMDA)	Enabled		
Dead Main Dead Aux (DMDA)	Enabled		
79	Enabled		
59 Main	Enabled		
59 Aux	Enabled		
27 Main	Enabled		
27 Aux	Enabled		
60	Enabled		
81-1	Fixed Level		
81-2	Fixed Level		
81-3	Rate of Change		
81-4	Rate of Change		
50LS Main (Input 1)	Enabled		
50LS Aux (Input 2)	Enabled		
50LS Input 3	Enabled		
50LS Input 4	Enabled		
50BF Main	Enabled		
50BF Aux	Enabled		
50	Enabled		
51	Enabled		
50N	Enabled		
51N	Enabled		
46-50	Enabled		
46-51	Enabled		
21P - Phase Distance: Zone 1			
21P - Zone 1	Enabled		
Forward Reach	11.52	ohm	0.05 to 66.00
Mho Char. Angle	90.0	deg	70.0 to 140.0
Pickup Delay	0.00	s	0.00 to 0.20
Delta Current Supervision	5.0	A	0.2 to 50.0
21P - Phase Distance: Zone 2			
21P - Zone 2	Enabled		
Forward Reach	17.28	ohm	0.05 to 66.00



L-PRO Settings Summary - Setting Group 1 [Setting Group 1]			
Mho Char. Angle	90.0	deg	70.0 to 140.0
Pickup Delay	0.40	s	0.00 to 2.00
Delta Current Supervision	5.0	A	0.2 to 50.0
21P - Phase Distance: Zone 3			
21P - Zone 3	Enabled		
Forward Reach	28.80	ohm	0.05 to 66.00
Reverse Reach	1.44	ohm	0.05 to 66.00
Mho Char. Angle	90.0	deg	70.0 to 140.0
Pickup Delay	1.00	s	0.00 to 5.00
Delta Current Supervision	5.0	A	0.2 to 50.0
21P - Phase Distance: Zone 4			
21P - Zone 4	Enabled		
Forward Reach	fixed at 0 (secondary ohm) for POTT or Blocking scheme		
Reverse Reach	11.52	ohm	0.05 to 66.00
Mho Char. Angle	90.0	deg	70.0 to 140.0
Pickup Delay	2.00	s	0.00 to 5.00
Delta Current Supervision	5.0	A	0.2 to 50.0
Load Impedance (common for 21N, 21P, and 68)			
Load Resistance (R)	20.0	ohm	-150.0 to 150.0
Load Reactance (X)	15.0	ohm	-150.0 to 150.0
21N - Ground Distance: Zone 1			
21N - Zone 1	Enabled		
Type	Mho		
Forward Reach	11.52	ohm	0.05 to 66.00
Left Reach (R1)	4.00	ohm	0.05 to 66.00
Right Reach (R2)	4.00	ohm	0.05 to 66.00
Mho Char. Angle	90.0	deg	70.0 to 140.0
Pickup Delay	0.00	s	0.00 to 0.20
Phase Current Supervision	5.0	A	0.2 to 50.0
3I0 Supervision	2.0	A	0.2 to 50.0
21N - Ground Distance: Zone 2			
21N - Zone 2	Enabled		
Type	Mho		
Forward Reach	17.28	ohm	0.05 to 66.00
Left Reach (R1)	6.00	ohm	0.05 to 66.00
Right Reach (R2)	6.00	ohm	0.05 to 66.00
Mho Char. Angle	90.0	deg	25.0 to 140.0

L-PRO Settings Summary - Setting Group 1 [Setting Group 1]			
Pickup Delay	0.40	s	0.00 to 2.00
Phase Current Supervision	5.0	A	0.2 to 50.0
3I0 Supervision	2.0	A	0.2 to 50.0
21N - Ground Distance: Zone 3			
21N - Zone 3	Enabled		
Type	Mho		
Forward Reach	28.80	ohm	0.05 to 66.00
Reverse Reach	1.44	ohm	0.05 to 66.00
Left Reach (R1)	8.00	ohm	0.05 to 66.00
Right Reach (R2)	8.00	ohm	0.05 to 66.00
Mho Char. Angle	90.0	deg	70.0 to 140.0
Pickup Delay	1.00	s	0.00 to 5.00
Phase Current Supervision	5.0	A	0.2 to 50.0
3I0 Supervision	2.0	A	0.2 to 50.0
21N - Ground Distance: Zone 4			
21N - Zone 4	Enabled		
Type	Mho		
Forward Reach	fixed at 0 (secondary ohm) for POTT or Blocking scheme		
Reverse Reach	11.52	ohm	0.05 to 66.00
Left Reach (R1)	4.00	ohm	0.05 to 66.00
Right Reach (R2)	4.00	ohm	0.05 to 66.00
Mho Char. Angle	90.0	deg	70.0 to 140.0
Pickup Delay	2.00	s	0.00 to 5.00
Phase Current Supervision	5.0	A	0.2 to 50.0
3I0 Supervision	2.0	A	0.2 to 50.0
68 - Out of Step Protection			
Mode	Off		
Zone 1 Blocking	Disabled		
Zone 2 Blocking	Disabled		
Zone 3 Blocking	Disabled		
Zone 4 Blocking	Disabled		
Out of step Swing Timer	0.50	s	0.00 to 1.00
I1 Supervision	10.0	A	0.5 to 50.0
3I0 Blocking	5.0	A	0.5 to 50.0
Blocking Reset Time	1.50	s	0.25 to 2.00
LHS Outer (R1)	-20.0	ohm	-100.0 to -17.0
LHS Inner (R2)	-17.0	ohm	-20.0 to 17.0
RHS Inner(R3)	17.0	ohm	-17.0 to 20.0

L-PRO Settings Summary - Setting Group 1 [Setting Group 1]			
RHS Outer(R4)	20.0	ohm	17.0 to 100.0
Dead Line Pickup			
Dead Line Pickup	Enabled		
27 Vpos Pickup	68.0	V	0.0 to 69.0
50 Pickup	10.0	A	0.5 to 50.0
50N Pickup	10.0	A	0.1 to 50.0
Second Harmonic Restraint	Enabled		
I2/I1 Ratio	5.1	-	0.0 to 10.0
Weak Infeed			
Weak Infeed	Enabled		
27 V1 Pickup	64.3	V	0.0 to 69.0
59 V0 Pickup	20.0	V	0.0 to 100.0
Zone2/Zone4 Reset Delay (TWD1)	0.10	s	0.02 to 0.20
Comm. Cycle Reset Delay (TWD2)	0.05	s	0.02 to 0.20
Comm. Reset Time Delay (TWD3)	0.15	s	0.02 to 1.00
25/27/59 - Sync Check			
25 Sync Check	Enabled		
Maximum Voltage	70.0	V	60.0 to 138.0
Minimum Voltage	40.0	V	40.0 to 69.9
Angle Difference	20.0	deg	1.0 to 50.0
Pickup Delay	0.10	s	0.00 to 10.00
Dead Main Live Sync (DMLS)	Enabled		
Live Main Dead Sync (LMDS)	Enabled		
Dead Main Dead Sync (DMDS)	Enabled		
79 - Recloser			
79	Enabled		
Number of Shots	1		
First Reclose (T1)	1.0	s	0.1 to 999.9
Second Reclose (T2)	5.0	s	1.0 to 999.9
Third Reclose (T3)	10.0	s	1.0 to 999.9
Fourth Reclose (T4)	20.0	s	1.0 to 999.9
Close Time (Tp)	0.2	s	0.1 to 1.0
Lockout Reset (TD)	25.0	s	0.1 to 999.9
Initiate Reset (TDI)	1.0	s	0.0 to 999.9
Sync Control	Disabled		
Recloser Mode	Main Only		
Block Reset (TDB)	0.5	s	0.0 to 999.9
Follower Time (TF)	5.0	s	0.0 to 24.9
Breaker Out of Service (TC)	50.0	s	0.0 to 999.9

L-PRO Settings Summary - Setting Group 1 [Setting Group 1]			
Follower Sequencer Switch	Close after the Recloser Follower Time (TF)		
59 - Overvoltage			
59 Main	Enabled		
Gate Switch	AND		
Pickup	50.0	V	1.0 to 138.0
Pickup Delay	0.00	s	0.00 to 10.00
59 Auxiliary	Enabled		
Gate Switch	AND		
Pickup	50.0	V	1.0 to 138.0
Pickup Delay	0.00	s	0.00 to 10.00
27 - Undervoltage			
27 Main	Enabled		
Gate Switch	AND		
Pickup	10.0	V	1.0 to 120.0
Pickup Delay	0.00	s	0.00 to 10.00
27 Auxiliary	Enabled		
Gate Switch	AND		
Pickup	10.0	V	1.0 to 120.0
Pickup Delay	0.00	s	0.00 to 10.00
Loss Of Potential Alarm (60)			
60	Enabled		
11 Blocking	10.0	A	0.5 to 50.0
310 Blocking	2.0	A	0.5 to 50.0
81 - Over/Under Frequency			
81-1	Fixed Level		
Pickup	60.005	Hz	[50.000, 59.995] or [60.005, 70.000]
Pickup Delay	2.00	s	0.05 to 99.99
81-2	Fixed Level		
Pickup	60.005	Hz	[50.000, 59.995] or [60.005, 70.000]
Pickup Delay	2.00	s	0.05 to 99.99
81-3	Rate of Change		
Pickup	10.0	Hz/s	[-10.0, -0.1] or [0.1, 10.0]
Pickup Delay	2.00	s	0.20 to 99.99
81-4	Rate of Change		
Pickup	10.0	Hz/s	[-10.0, -0.1] or [0.1, 10.0]

L-PRO Settings Summary - Setting Group 1 [Setting Group 1]			
Pickup Delay	2.00	s	0.20 to 99.99
50LS - Low Set Overcurrent			
50LS Main (Input 1)	Enabled		
Pickup	0.50	A	0.10 to 50.00
Pickup Delay	0.00	s	0.00 to 10.00
50LS Auxiliary (Input 2)	Enabled		
Pickup	0.50	A	0.10 to 50.00
Pickup Delay	0.00	s	0.00 to 10.00
50LS Input 3	Enabled		
Pickup	0.50	A	0.10 to 50.00
Pickup Delay	0.00	s	0.00 to 10.00
50LS Input 4	Enabled		
Pickup	0.50	A	0.10 to 50.00
Pickup Delay	0.00	s	0.00 to 10.00
50BF - Breaker Failure			
50BF Main	Enabled		
Pickup Delay 1	0.50	s	0.01 to 99.99
Pickup Delay 2	1.50	s	0.01 to 99.99
50BF Auxiliary	Enabled		
Pickup Delay 1	0.50	s	0.01 to 99.99
Pickup Delay 2	1.50	s	0.01 to 99.99
50/51/67 - Phase Overcurrent			
50	Enabled		
Directional Control	forward		
Pickup	10.00	A	0.50 to 50.00
Pickup Delay	1.00	A	0.01 to 99.99
51	Enabled		
Directional Control	forward		
Pickup	10.00	A	0.50 to 50.00
Curve Type	IEC very inverse		
TMS	0.50	-	0.01 to 10.00
A	13.5	-	-
B	0.0	-	-
p	1.0	-	-
TR	47.30	-	-
50N/51N/67 - Neutral Overcurrent			
50N	Enabled		
Directional Control	forward		
Pickup	10.00	A	0.50 to 50.00

L-PRO Settings Summary - Setting Group 1 [Setting Group 1]			
Pickup Delay	1.00	A	0.01 to 99.99
51N	Enabled		
Directional Control	forward		
Pickup	10.00	A	0.50 to 50.00
Curve Type	IEC very inverse		
TMS	0.50	-	0.01 to 10.00
A	13.5	-	-
B	0.0	-	-
p	1.0	-	-
TR	47.30	-	-
46-50/46-51/67 - Negative Sequence Overcurrent			
46-50	Enabled		
Directional Control	forward		
Pickup	10.00	A	0.50 to 50.00
Pickup Delay	1.00	A	0.01 to 99.99
46-51	Enabled		
Directional Control	forward		
Pickup	10.00	A	0.50 to 50.00
Curve Type	IEC very inverse		
TMS	0.50	-	0.01 to 10.00
A	13.5	-	-
B	0.0	-	-
p	1.0	-	-
TR	47.30	-	-
Z Circle Trigger			
Swing Trigger	Disabled		
+ve Seq. Impedance	20.0	ohm	0.1 to 50.0
ProLogic 1 [ProLogic 1]			
[ProLogic 1]	Disabled		
Target	Enabled		
Pickup Delay	0.00	s	0.00 to 999.00
Dropout Delay	0.00	s	0.00 to 999.00
Operator 1			
Input A	<Unused = 0>		
Operator 2			
Input B	<Unused = 0>		
Operator 3			
Input C	<Unused = 0>		

L-PRO Settings Summary - Setting Group 1 [Setting Group 1]			
Operator 4			
Input D	<Unused = 0>		
Operator 5			
Input E	<Unused = 0>		
ProLogic 2 [ProLogic 2]			
[ProLogic 2]	Disabled		
Target	Enabled		
Pickup Delay	0.00	s	0.00 to 999.00
Dropout Delay	0.00	s	0.00 to 999.00
Operator 1			
Input A	<Unused = 0>		
Operator 2			
Input B	<Unused = 0>		
Operator 3			
Input C	<Unused = 0>		
Operator 4			
Input D	<Unused = 0>		
Operator 5			
Input E	<Unused = 0>		
ProLogic 3 [ProLogic 3]			
[ProLogic 3]	Disabled		
Target	Enabled		
Pickup Delay	0.00	s	0.00 to 999.00
Dropout Delay	0.00	s	0.00 to 999.00
Operator 1			
Input A	<Unused = 0>		
Operator 2			
Input B	<Unused = 0>		
Operator 3			
Input C	<Unused = 0>		
Operator 4			
Input D	<Unused = 0>		
Operator 5			
Input E	<Unused = 0>		
ProLogic 4 [ProLogic 4]			
[ProLogic 4]	Disabled		
Target	Enabled		
Pickup Delay	0.00	s	0.00 to 999.00
Dropout Delay	0.00	s	0.00 to 999.00

L-PRO Settings Summary - Setting Group 1 [Setting Group 1]			
Operator 1			
Input A	<Unused = 0>		
Operator 2			
Input B	<Unused = 0>		
Operator 3			
Input C	<Unused = 0>		
Operator 4			
Input D	<Unused = 0>		
Operator 5			
Input E	<Unused = 0>		
ProLogic 5 [ProLogic 5]			
[ProLogic 5]	Disabled		
Target	Enabled		
Pickup Delay	0.00	s	0.00 to 999.00
Dropout Delay	0.00	s	0.00 to 999.00
Operator 1			
Input A	<Unused = 0>		
Operator 2			
Input B	<Unused = 0>		
Operator 3			
Input C	<Unused = 0>		
Operator 4			
Input D	<Unused = 0>		
Operator 5			
Input E	<Unused = 0>		
ProLogic 6 [ProLogic 6]			
[ProLogic 6]	Disabled		
Target	Enabled		
Pickup Delay	0.00	s	0.00 to 999.00
Dropout Delay	0.00	s	0.00 to 999.00
Operator 1			
Input A	<Unused = 0>		
Operator 2			
Input B	<Unused = 0>		
Operator 3			
Input C	<Unused = 0>		
Operator 4			
Input D	<Unused = 0>		
Operator 5			



L-PRO Settings Summary - Setting Group 1 [Setting Group 1]			
Input E	<Unused = 0>		
ProLogic 7 [ProLogic 7]			
[ProLogic 7]	Disabled		
Target	Enabled		
Pickup Delay	0.00	s	0.00 to 999.00
Dropout Delay	0.00	s	0.00 to 999.00
Operator 1			
Input A	<Unused = 0>		
Operator 2			
Input B	<Unused = 0>		
Operator 3			
Input C	<Unused = 0>		
Operator 4			
Input D	<Unused = 0>		
Operator 5			
Input E	<Unused = 0>		
ProLogic 8 [ProLogic 8]			
[ProLogic 8]	Disabled		
Target	Enabled		
Pickup Delay	0.00	s	0.00 to 999.00
Dropout Delay	0.00	s	0.00 to 999.00
Operator 1			
Input A	<Unused = 0>		
Operator 2			
Input B	<Unused = 0>		
Operator 3			
Input C	<Unused = 0>		
Operator 4			
Input D	<Unused = 0>		
Operator 5			
Input E	<Unused = 0>		
ProLogic 9 [ProLogic 9]			
[ProLogic 9]	Disabled		
Target	Enabled		
Pickup Delay	0.00	s	0.00 to 999.00
Dropout Delay	0.00	s	0.00 to 999.00
Operator 1			
Input A	<Unused = 0>		
Operator 2			

L-PRO Settings Summary - Setting Group 1 [Setting Group 1]			
Input B	<Unused = 0>		
Operator 3			
Input C	<Unused = 0>		
Operator 4			
Input D	<Unused = 0>		
Operator 5			
Input E	<Unused = 0>		
ProLogic 10 [ProLogic 10]			
[ProLogic 10]	Disabled		
Target	Enabled		
Pickup Delay	0.00	s	0.00 to 999.00
Dropout Delay	0.00	s	0.00 to 999.00
Operator 1			
Input A	<Unused = 0>		
Operator 2			
Input B	<Unused = 0>		
Operator 3			
Input C	<Unused = 0>		
Operator 4			
Input D	<Unused = 0>		
Operator 5			
Input E	<Unused = 0>		
ProLogic 11 [ProLogic 11]			
[ProLogic 11]	Disabled		
Target	Enabled		
Pickup Delay	0.00	s	0.00 to 999.00
Dropout Delay	0.00	s	0.00 to 999.00
Operator 1			
Input A	<Unused = 0>		
Operator 2			
Input B	<Unused = 0>		
Operator 3			
Input C	<Unused = 0>		
Operator 4			
Input D	<Unused = 0>		
Operator 5			
Input E	<Unused = 0>		
ProLogic 12 [ProLogic 12]			
[ProLogic 12]	Disabled		

L-PRO Settings Summary - Setting Group 1 [Setting Group 1]			
Target	Enabled		
Pickup Delay	0.00	s	0.00 to 999.00
Dropout Delay	0.00	s	0.00 to 999.00
Operator 1			
Input A	<Unused = 0>		
Operator 2			
Input B	<Unused = 0>		
Operator 3			
Input C	<Unused = 0>		
Operator 4			
Input D	<Unused = 0>		
Operator 5			
Input E	<Unused = 0>		
Group Logic 1 [Group Logic 1]			
[Group Logic 1]	Disabled		
Setting Group to Activate	none		
Pickup Delay	0	s	0 to 999
Operator 1			
Input A	<Unused = 0>		
Operator 2			
Input B	<Unused = 0>		
Operator 3			
Input C	<Unused = 0>		
Operator 4			
Input D	<Unused = 0>		
Operator 5			
Input E	<Unused = 0>		
Group Logic 2 [Group Logic 2]			
[Group Logic 2]	Disabled		
Setting Group to Activate	none		
Pickup Delay	0	s	0 to 999
Operator 1			
Input A	<Unused = 0>		
Operator 2			
Input B	<Unused = 0>		
Operator 3			
Input C	<Unused = 0>		
Operator 4			
Input D	<Unused = 0>		

L-PRO Settings Summary - Setting Group 1 [Setting Group 1]			
Operator 5			
Input E	<Unused = 0>		
Group Logic 3 [Group Logic 3]			
[Group Logic 3]	Disabled		
Setting Group to Activate	none		
Pickup Delay	0	s	0 to 999
Operator 1			
Input A	<Unused = 0>		
Operator 2			
Input B	<Unused = 0>		
Operator 3			
Input C	<Unused = 0>		
Operator 4			
Input D	<Unused = 0>		
Operator 5			
Input E	<Unused = 0>		
Group Logic 4 [Group Logic 4]			
[Group Logic 4]	Disabled		
Setting Group to Activate	none		
Pickup Delay	0	s	0 to 999
Operator 1			
Input A	<Unused = 0>		
Operator 2			
Input B	<Unused = 0>		
Operator 3			
Input C	<Unused = 0>		
Operator 4			
Input D	<Unused = 0>		
Operator 5			
Input E	<Unused = 0>		
Group Logic 5 [Group Logic 5]			
[Group Logic 5]	Disabled		
Setting Group to Activate	none		
Pickup Delay	0	s	0 to 999
Operator 1			
Input A	<Unused = 0>		
Operator 2			
Input B	<Unused = 0>		
Operator 3			

L-PRO Settings Summary - Setting Group 1 [Setting Group 1]			
Input C	<Unused = 0>		
Operator 4			
Input D	<Unused = 0>		
Operator 5			
Input E	<Unused = 0>		
Group Logic 6 [Group Logic 6]			
[Group Logic 6]	Disabled		
Setting Group to Activate	none		
Pickup Delay	0	s	0 to 999
Operator 1			
Input A	<Unused = 0>		
Operator 2			
Input B	<Unused = 0>		
Operator 3			
Input C	<Unused = 0>		
Operator 4			
Input D	<Unused = 0>		
Operator 5			
Input E	<Unused = 0>		
Group Logic 7 [Group Logic 7]			
[Group Logic 7]	Disabled		
Setting Group to Activate	none		
Pickup Delay	0	s	0 to 999
Operator 1			
Input A	<Unused = 0>		
Operator 2			
Input B	<Unused = 0>		
Operator 3			
Input C	<Unused = 0>		
Operator 4			
Input D	<Unused = 0>		
Operator 5			
Input E	<Unused = 0>		
Group Logic 8 [Group Logic 8]			
[Group Logic 8]	Disabled		
Setting Group to Activate	none		
Pickup Delay	0	s	0 to 999
Operator 1			
Input A	<Unused = 0>		

L-PRO Settings Summary - Setting Group 1 [Setting Group 1]			
Operator 2			
Input B	<Unused = 0>		
Operator 3			
Input C	<Unused = 0>		
Operator 4			
Input D	<Unused = 0>		
Operator 5			
Input E	<Unused = 0>		
Group Logic 9 [Group Logic 9]			
[Group Logic 9]	Disabled		
Setting Group to Activate	none		
Pickup Delay	0	s	0 to 999
Operator 1			
Input A	<Unused = 0>		
Operator 2			
Input B	<Unused = 0>		
Operator 3			
Input C	<Unused = 0>		
Operator 4			
Input D	<Unused = 0>		
Operator 5			
Input E	<Unused = 0>		
Group Logic 10 [Group Logic 10]			
[Group Logic 10]	Disabled		
Setting Group to Activate	none		
Pickup Delay	0	s	0 to 999
Operator 1			
Input A	<Unused = 0>		
Operator 2			
Input B	<Unused = 0>		
Operator 3			
Input C	<Unused = 0>		
Operator 4			
Input D	<Unused = 0>		
Operator 5			
Input E	<Unused = 0>		
Group Logic 11 [Group Logic 11]			
[Group Logic 11]	Disabled		
Setting Group to Activate	none		

L-PRO Settings Summary - Setting Group 1 [Setting Group 1]			
Pickup Delay	0	s	0 to 999
Operator 1			
Input A	<Unused = 0>		
Operator 2			
Input B	<Unused = 0>		
Operator 3			
Input C	<Unused = 0>		
Operator 4			
Input D	<Unused = 0>		
Operator 5			
Input E	<Unused = 0>		
Group Logic 12 [Group Logic 12]			
[Group Logic 12]	Disabled		
Setting Group to Activate	none		
Pickup Delay	0	s	0 to 999
Operator 1			
Input A	<Unused = 0>		
Operator 2			
Input B	<Unused = 0>		
Operator 3			
Input C	<Unused = 0>		
Operator 4			
Input D	<Unused = 0>		
Operator 5			
Input E	<Unused = 0>		
Group Logic 13 [Group Logic 13]			
[Group Logic 13]	Disabled		
Setting Group to Activate	none		
Pickup Delay	0	s	0 to 999
Operator 1			
Input A	<Unused = 0>		
Operator 2			
Input B	<Unused = 0>		
Operator 3			
Input C	<Unused = 0>		
Operator 4			
Input D	<Unused = 0>		
Operator 5			
Input E	<Unused = 0>		

L-PRO Settings Summary - Setting Group 1 [Setting Group 1]			
Group Logic 14 [Group Logic 14]			
[Group Logic 14]	Disabled		
Setting Group to Activate	none		
Pickup Delay	0	s	0 to 999
Operator 1			
Input A	<Unused = 0>		
Operator 2			
Input B	<Unused = 0>		
Operator 3			
Input C	<Unused = 0>		
Operator 4			
Input D	<Unused = 0>		
Operator 5			
Input E	<Unused = 0>		
Group Logic 15 [Group Logic 15]			
[Group Logic 15]	Disabled		
Setting Group to Activate	none		
Pickup Delay	0	s	0 to 999
Operator 1			
Input A	<Unused = 0>		
Operator 2			
Input B	<Unused = 0>		
Operator 3			
Input C	<Unused = 0>		
Operator 4			
Input D	<Unused = 0>		
Operator 5			
Input E	<Unused = 0>		
Group Logic 16 [Group Logic 16]			
[Group Logic 16]	Disabled		
Setting Group to Activate	none		
Pickup Delay	0	s	0 to 999
Operator 1			
Input A	<Unused = 0>		
Operator 2			
Input B	<Unused = 0>		
Operator 3			
Input C	<Unused = 0>		
Operator 4			



---

L-PRO Settings Summary - Setting Group 1 [Setting Group 1]			
Input D	<Unused = 0>		
Operator 5			
Input E	<Unused = 0>		



---

# Appendix C Hardware Description

The L-PRO is a sophisticated transformer protection relay with integral high-quality fault recording.

## External Input and Comm Board

The L-PRO Relay has 9 channels of external inputs provided by the External Input and Comm Board. Inputs are optically isolated, factory pre-set to the customer's requested voltage level. Two dual-range user-selectable external-input voltage-level model of the External Input and Comm Board are available. This allows you to select between 48 Vdc and 125 Vdc or 125 Vdc and 250 Vdc (nominal) on a per input basis.

The External Input and Comm Board also provides the relay with 2 rear-panel RS-232 ports, IRIG-B time synchronization input, and optional network or telephone connection. The RS-232 ports are female DB-9S connectors, IRIG-B is a male BNC, and network or telephone is a female RJ-45 modular jack.

## Relay Output Board

The Relay Output Board provides 14 normally open contact outputs for relaying, alarms and control, one normally closed output contact for indicating proper relay operation.

## Power Supply Board

The power supply operates from 40 to 300 Vdc or 120 Vac +/- 20% at 50/60 Hz. This wide operating range provides easier installation by eliminating power supply ordering options.

## AC Analog Input Board

The AC Analog Input Board has 12 current transformer inputs and 6 potential transformer inputs for ac current and voltage inputs. On-board anti-aliasing filters provide accurate and secure digitization of the ac input signals.

## Main Processor Board (MPB)

The MPB has analog data acquisition, high-speed digital signal processing for triggering and data conversion, communications, and interface logic to perform the core functions of the relay.

The Digital Signal Processor (DSP) on a MPB performs the protective relaying functions of the relay, separate from the 486 CPU. It has its own flash memory and self-checking for fully independent operation.

The Main Processor Board has:

- 24 channels of high-speed 12 bit-plus-sign analog-to-digital conversion
- Re-programmable flash memory for the DSP allows independent relay operation and field software upgrades
- Floating point DSP for fast capture and manipulation of data
- Standard RS-232 serial communications ports
- High speed link between DSP and 486 processors
- Time synchronism processor with automatic detection of modulated and unmodulated IRIG-B
- Sophisticated fault detection and "watchdog" recovery hardware

## 486 CPU Board

A 486-class CPU provides data storage, information management, housekeeping, and communications for the relay. The 486 runs a real-time operating sys-

tem optimized for high speed, high precision computing. The 486 provides sophisticated facilities for communications and field software updates. Local and wide area networking is supported by providing the relay with a path to future networking capability.

A highly reliable solid-state flash disk on the CPU board provides the operating software for the 486, and stores the relay's recordings.

### Front Panel Board

The Front Panel Board provides visual indication of the status of the relay, an alphanumeric display and keypad for system monitoring, and a front-panel RS-232 port.

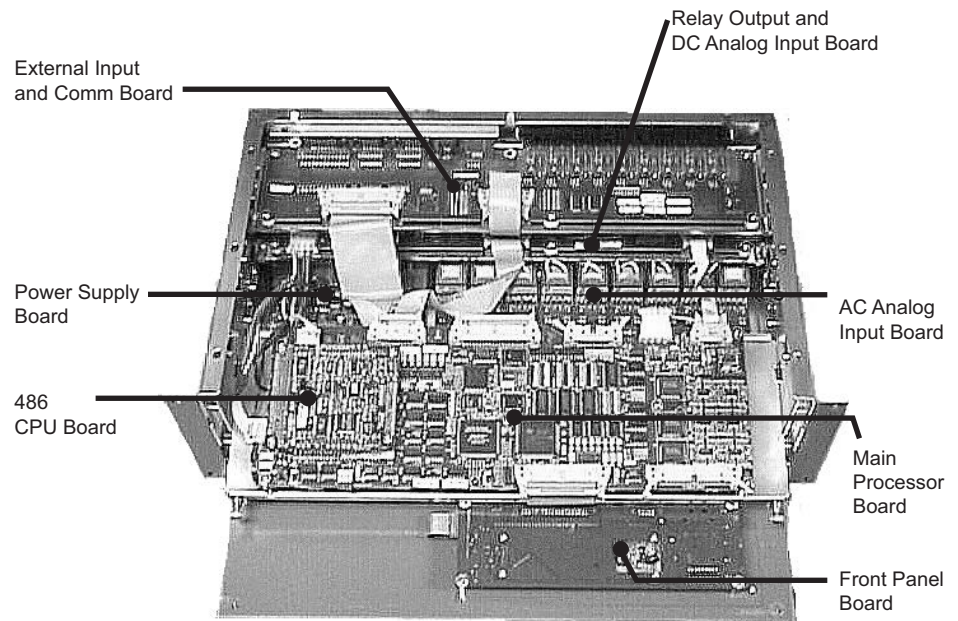

# Appendix D Event Messages

L-PRO Event Messages	
Event Log Message	Notes
21P1 ABC 12.3km:Trip	The possible phase information for 21P1–21P4 will be: <ul style="list-style-type: none"> <li>• AB</li> <li>• BC</li> <li>• CA</li> <li>• AB, BC</li> <li>• AB, CA</li> <li>• CA, BC</li> <li>• ABC</li> <li>• ABG</li> <li>• BCG</li> <li>• CAG</li> <li>• ABGBC</li> <li>• BCGCA</li> <li>• CAGAB</li> <li>• ABCG</li> </ul>
21P2 ABC 12.3km:Trip	
21P3 ABC 12.3km:Trip	
21P4 ABC 12.3km:Trip	
21N1 AG 12.3km:Trip	The possible phase information for 21N1–N4 will be: <ul style="list-style-type: none"> <li>• AG</li> <li>• BG</li> <li>• CG</li> <li>• ABG</li> <li>• BCG</li> <li>• CAG</li> <li>• ABCG</li> </ul>
21N2 AG 12.3km:Trip	
21N3 AG 12.3km:Trip	
21N4 AG 12.3km:Trip	
21P2 ABC 12.3km:Alarm	The possible phase information for 21P2–21P4 will be: <ul style="list-style-type: none"> <li>• AB</li> <li>• BC</li> <li>• CA</li> <li>• AB, BC</li> <li>• AB, CA</li> <li>• CA, BC</li> <li>• ABC</li> <li>• ABG</li> <li>• BCG</li> <li>• CAG</li> <li>• ABGBC</li> <li>• BCGCA</li> <li>• CAGAB</li> <li>• ABCG</li> </ul>
21P3 ABC 12.3km:Alarm	
21P4 ABC 12.3km:Alarm	
21N2 AG 12.3km:Alarm	The possible phase information for 21N2–N4 and 50N/51N will be: <ul style="list-style-type: none"> <li>• AG</li> <li>• BG</li> <li>• CG</li> <li>• ABG</li> <li>• BCG</li> <li>• CAG</li> <li>• ABCG</li> </ul>
21N3 AG 12.3km:Alarm	
21N4 AG 12.3km:Alarm	
51N AG 12.3km:Trip	
50N AG 12.3km:Trip	
46-51: Trip	
46-50: Trip	
51 ABC:Trip	The possible phase information will be: <ul style="list-style-type: none"> <li>• A</li> <li>• B</li> <li>• C</li> <li>• AB</li> <li>• BC</li> <li>• CA</li> <li>• ABC</li> </ul>
50 ABC:Trip	
51N: Alarm	
46-51: Alarm	

L-PRO Event Messages	
51 ABC: Alarm	The possible phase information will be: <ul style="list-style-type: none"> <li>• A</li> <li>• B</li> <li>• C</li> <li>• AB</li> <li>• BC</li> <li>• CA</li> <li>• ABC</li> </ul>
Impedance Circle Trigger	
68 Out of Step: Trip	Trip or Alarm based on 68 mode setting
PUTT 12.3 km: Trip	
DCB 12.3 km: Trip	
POTT 12.3 km: Trip	
POTT (WI) 12.3 km: Trip	Weak Infeed (WI) is not available unless POTT is selected.
PUTT: Send	
POTT: Send	
POTT: Send (WI)	Weak Infeed (WI) is not available unless POTT is selected.
DCB: Send	
Dead Line Pickup ABC	The possible phase information will be: <ul style="list-style-type: none"> <li>• A</li> <li>• B</li> <li>• C</li> <li>• AB</li> <li>• BC</li> <li>• CA</li> <li>• ABC</li> </ul>
ProLogic Name: PLn	ProLogic outputs names are user assigned
Extern Input Name: EIn: High	External input names are user assigned
Extern Input Name: EIn: Low	External input names are user assigned
Virtual Inputs: EIn: High	Virtual Inputs are user assigned
Virtual Inputs: EIn: High	Virtual Inputs are user assigned
Output Contacts: EIn: High	Output Contact Names are user assigned
Output Contacts: EIn: High	Output Contacts names are user assigned
60 LOP ABC: Alarm	The possible phase information will be: <ul style="list-style-type: none"> <li>• A</li> <li>• B</li> <li>• C</li> <li>• AB</li> <li>• BC</li> <li>• CA</li> <li>• ABC</li> </ul>
68 Inner Blinder: Alarm	
68 Outer Blinder: Alarm	
Com-Aided (Z2,Wi): Send	Scheme types: WI, Z2, Z2 & WI, Z2 is Zone 2 POTT and WI is Weak Infeed

L-PRO Event Messages	
27 Main ABC: Trip	The possible phase information will be: • A • B • C • AB • BC • CA • ABC
27 Aux. ABC: Trip	
59 Main ABC: Trip	
59 Aux. ABC: Trip	
50LS Main ABC: Trip	
50LS Aux. ABC: Trip	
252759 Sync Check: Armed	
50BF-1 Main ABC:Trip	The possible phase information will be: • A • B • C • AB • BC • CA • ABC
50BF-2 Main ABC:Trip	
50BF-1 Aux ABC:Trip	
50BF-2 Aux ABC:Trip	
81-1: Trip	
81-2: Trip	
81-3: Trip	
81-4: Trip	
79 Initiated: High	Recloser is initiated.
79 Lead Lockout: High	Recloser shot count has expired and reclosing attempts are blocked.
79 Follow Lockout: High	Follow breaker has failed to reclose.
79 Main Reclose: shot n	Recloser Main circuit breaker close attempt where n equals the shot count.
79 Follow Reclose: shot n	Recloser Aux. circuit breaker close attempt where n equals the shot count.
79 Block: High	Recloser is blocked by an external signal.
Self Check: DC Ch.n: Alarm	Continuous dc level on Ch. n, where n = 1 to 18.
Self Check: DC Alarm Reset	Continuous dc level, condition has reset.
Self Check: DC Ch.n: O/P Block	Continuous dc level on Ch. n, where n = 1 to 18. Relay is blocked.
New Settings loaded, Active group n.	Where n = 1-8
New Setting Loaded	
Manual Settings Load request, activate SGn	Manual or user-initiated settings change.
Manual Settings Load request completed	Completion of user-initiated settings change.
Changed Active Group from x to y Logic n	This happens when relay changes setting group. Automatic group logic initiated setting group change
User changed Active Group from x to y	This happens when the relay changes setting group. User initiated setting group change

L-PRO Event Messages	
Unit Recalibrated	
Unit restarted	
User logged In	

### Details of Failure Modes

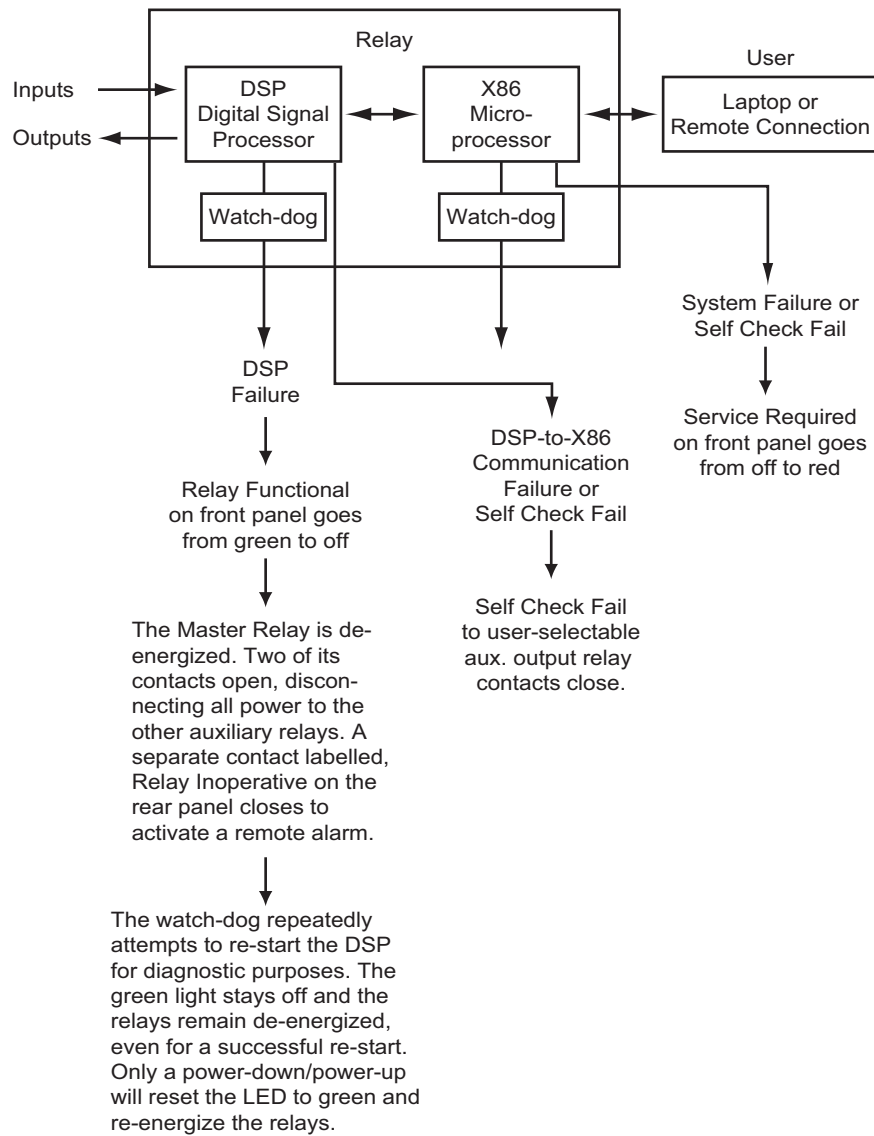

**Note:** For either of the above cases the DSP controller functions continue with normal auxiliary relay outputs provided that DSP failure or Self Check Fail: Block has not occurred.



## Self Check Fail due to DC Offset Detector

The DSP has an algorithm that detects continuous dc levels on the analog inputs and initiates alarms and relay output contact blocking when the measured dc level exceeds the Alarm or Block level. The Alarm level is intended to provide an early indication of a problem. The Block level blocks the relay from false-tripping by preventing any output contact from closing. The Relay Functional LED turns off, but the protection functions will operate normally, with the exception that the output contacts will not be allowed to close. The Relay Inoperative contact will close for a Block condition. The following table describes all the Alarm/Block indication functions

Action	Condition	
	Alarm	Block
Relay Functional LED off		X
Service Required LED on	X	X
Self Check Fail Signal high	X	X
Relay Inoperative Contact closed		X
Output Contacts held open		X
Event Log Message	X	X
Status available through SCADA	X	X

The Self Check Fail signal, which is available in the Output Matrix, TUI metering and SCADA, can be used to signal an alarm. Note that if this signal is mapped to an output contact, the contact which it is mapped to will only be closed for an alarm condition. If the relay is in the Block condition, the Relay Inoperative contact must be used to signal an alarm.

The status of the Self Check Fail is available through the SCADA services provided by the L-PRO. The digital signal Self Check Fail will indicate that DSP has detected a continuous dc level and the analog metering value Self Check Fail Parameter is used to indicate which condition, Alarm or Block. The failure types and which analog values they are associated with are described in the table below. Both signals are available in DNP and Modbus.

Point Value	Condition
0	Normal
1	Alarm
2	Block
3	Alarm has evolved to block

The Alarm condition is allowed to reset if the continuous dc level drops below the pickup level. The Block condition has no reset level. If power is cycled to the relay it will go into its normal state until the continuous dc level is detected again.

Self Check Fail appears as "Aux. Failure Alarm" in the settings versions before V 10.

# Appendix E Modbus RTU Communication Protocol

The SCADA port supports DNP3 and Modicon Modbus protocols. All metering values available through the terminal user interface are also available via the Modbus protocol. Additionally, the Modbus protocol supports the reading of unit time and time of the readings and provides access to trip and alarm events, including fault location information.

A “Hold Readings” function is available to freeze all metering readings into a snapshot (see Force Single Coil function, address 0).

Read Coil Status (Function Code 01)			
Channel	Address	Value	
Hold Readings	1	0: Readings not held	1: Readings held
Reserved	257	Reserved	Reserved
Output Contact 1	513	0: Contact Open (inactive)	1: Contact Closed (active)
Output Contact 2	514	0: Contact Open (inactive)	1: Contact Closed (active)
Output Contact 3	515	0: Contact Open (inactive)	1: Contact Closed (active)
Output Contact 4	516	0: Contact Open (inactive)	1: Contact Closed (active)
Output Contact 5	517	0: Contact Open (inactive)	1: Contact Closed (active)
Output Contact 6	518	0: Contact Open (inactive)	1: Contact Closed (active)
Output Contact 7	519	0: Contact Open (inactive)	1: Contact Closed (active)
Output Contact 8	520	0: Contact Open (inactive)	1: Contact Closed (active)
Output Contact 9	521	0: Contact Open (inactive)	1: Contact Closed (active)
Output Contact 10	522	0: Contact Open (inactive)	1: Contact Closed (active)
Output Contact 11	523	0: Contact Open (inactive)	1: Contact Closed (active)
Output Contact 12	524	0: Contact Open (inactive)	1: Contact Closed (active)
Output Contact 13	525	0: Contact Open (inactive)	1: Contact Closed (active)
Output Contact 14	526	0: Contact Open (inactive)	1: Contact Closed (active)
Output Contact 15	527	0: Contact Open (inactive)	1: Contact Closed (active)
Output Contact 16	528	0: Contact Open (inactive)	1: Contact Closed (active)
Output Contact 17	529	0: Contact Open (inactive)	1: Contact Closed (active)
Output Contact 18	530	0: Contact Open (inactive)	1: Contact Closed (active)
Output Contact 19	531	0: Contact Open (inactive)	1: Contact Closed (active)
Output Contact 20	532	0: Contact Open (inactive)	1: Contact Closed (active)
Output Contact 21	533	0: Contact Open (inactive)	1: Contact Closed (active)
21P1 Trip	769	0: Off (inactive)	1: On (active)
21P2 Trip	770	0: Off (inactive)	1: On (active)
21P3 Trip	771	0: Off (inactive)	1: On (active)
21P4 Trip	772	0: Off (inactive)	1: On (active)
51 Trip	773	0: Off (inactive)	1: On (active)
50 Trip	774	0: Off (inactive)	1: On (active)
21N1 Trip	775	0: Off (inactive)	1: On (active)
21N2 Trip	776	0: Off (inactive)	1: On (active)
21N3 Trip	777	0: Off (inactive)	1: On (active)
21N4 Trip	778	0: Off (inactive)	1: On (active)
68 Out of Step	779	0: Off (inactive)	1: On (active)
ZCircle Trigger	780	0: Off (inactive)	1: On (active)
51N Trip	781	0: Off (inactive)	1: On (active)

Read Coil Status (Function Code 01)			
50N Trip	782	0: Off (inactive)	1: On (active)
46-51 Trip	783	0: Off (inactive)	1: On (active)
46-50 Trip	784	0: Off (inactive)	1: On (active)
Deadline Trip	785	0: Off (inactive)	1: On (active)
Comm Scheme Trip	786	0: Off (inactive)	1: On (active)
Comm Scheme Send	787	0: Off (inactive)	1: On (active)
60 Alarm	788	0: Off (inactive)	1: On (active)
21P2 Alarm	789	0: Off (inactive)	1: On (active)
21P3 Alarm	790	0: Off (inactive)	1: On (active)
21P4 Alarm	791	0: Off (inactive)	1: On (active)
21N2 Alarm	792	0: Off (inactive)	1: On (active)
21N3 Alarm	793	0: Off (inactive)	1: On (active)
21N4 Alarm	794	0: Off (inactive)	1: On (active)
51 Alarm	795	0: Off (inactive)	1: On (active)
51N Alarm	796	0: Off (inactive)	1: On (active)
46-51 Alarm	797	0: Off (inactive)	1: On (active)
Self Check Fail	798	0: Off (inactive)	1: On (active)
ProLogic1	799	0: Off (inactive)	1: On (active)
ProLogic2	800	0: Off (inactive)	1: On (active)
ProLogic3	801	0: Off (inactive)	1: On (active)
ProLogic4	802	0: Off (inactive)	1: On (active)
ProLogic5	803	0: Off (inactive)	1: On (active)
ProLogic6	804	0: Off (inactive)	1: On (active)
ProLogic7	805	0: Off (inactive)	1: On (active)
ProLogic8	806	0: Off (inactive)	1: On (active)
ProLogic9	807	0: Off (inactive)	1: On (active)
ProLogic10	808	0: Off (inactive)	1: On (active)
68 OutBlinder Alarm	809	0: Off (inactive)	1: On (active)
68 InBlinder Alarm	810	0: Off (inactive)	1: On (active)
27 Main Trip	811	0: Off (inactive)	1: On (active)
27 Aux Trip	812	0: Off (inactive)	1: On (active)
59 Main Trip	813	0: Off (inactive)	1: On (active)
59 Aux Trip	814	0: Off (inactive)	1: On (active)
50LS Main	815	0: Off (inactive)	1: On (active)
25/27/59 Sync Check	816	0: Off (inactive)	1: On (active)
50LS Aux	817	0: Off (inactive)	1: On (active)
Group Logic 1	818	0: Off (inactive)	1: On (active)
Group Logic 2	819	0: Off (inactive)	1: On (active)
Group Logic 3	820	0: Off (inactive)	1: On (active)
Group Logic 4	821	0: Off (inactive)	1: On (active)
Group Logic 5	822	0: Off (inactive)	1: On (active)
Group Logic 6	823	0: Off (inactive)	1: On (active)
Group Logic 7	824	0: Off (inactive)	1: On (active)
Group Logic 8	825	0: Off (inactive)	1: On (active)
Group Logic 9	826	0: Off (inactive)	1: On (active)
Group Logic 10	827	0: Off (inactive)	1: On (active)
Group Logic 11	828	0: Off (inactive)	1: On (active)
Group Logic 12	829	0: Off (inactive)	1: On (active)
Group Logic 13	830	0: Off (inactive)	1: On (active)
Group Logic 14	831	0: Off (inactive)	1: On (active)
Group Logic 15	832	0: Off (inactive)	1: On (active)
Group Logic 16	833	0: Off (inactive)	1: On (active)
79 Initiated	834	0: Off (inactive)	1: On (active)

Read Coil Status (Function Code 01)			
79 Blocked	835	0: Off (inactive)	1: On (active)
50BF-1 Main	836	0: Off (inactive)	1: On (active)
50BF-2 Main	837	0: Off (inactive)	1: On (active)
50BF-1 Aux	838	0: Off (inactive)	1: On (active)
50BF-2 Aux	839	0: Off (inactive)	1: On (active)
79 Main Reclose	840	0: Off (inactive)	1: On (active)
79 Aux Reclose	841	0: Off (inactive)	1: On (active)
79 Lead Lockout	842	0: Off (inactive)	1: On (active)
79 Follow Lockout	843	0: Off (inactive)	1: On (active)
81-1 Trip	844	0: Off (inactive)	1: On (active)
81-2 Trip	845	0: Off (inactive)	1: On (active)
81-3 Trip	846	0: Off (inactive)	1: On (active)
81-4 Trip	847	0: Off (inactive)	1: On (active)
50BF Initiate	848	0: Off (inactive)	1: On (active)
ProLogic 11	849	0: Off (inactive)	1: On (active)
ProLogic 12	850	0: Off (inactive)	1: On (active)

Read Input Status (Function Code 02)			
Channel	Address	Value	
External Input 1	10001	0: Off (inactive)	1: On (active)
External Input 2	10002	0: Off (inactive)	1: On (active)
External Input 3	10003	0: Off (inactive)	1: On (active)
External Input 4	10004	0: Off (inactive)	1: On (active)
External Input 5	10005	0: Off (inactive)	1: On (active)
External Input 6	10006	0: Off (inactive)	1: On (active)
External Input 7	10007	0: Off (inactive)	1: On (active)
External Input 8	10008	0: Off (inactive)	1: On (active)
External Input 9	10009	0: Off (inactive)	1: On (active)
External Input 10	10010	0: Off (inactive)	1: On (active)
External Input 11	10011	0: Off (inactive)	1: On (active)
External Input 12	10012	0: Off (inactive)	1: On (active)
External Input 13	10013	0: Off (inactive)	1: On (active)
External Input 14	10014	0: Off (inactive)	1: On (active)
External Input 15	10015	0: Off (inactive)	1: On (active)
External Input 16	10016	0: Off (inactive)	1: On (active)
External Input 17	10017	0: Off (inactive)	1: On (active)
External Input 18	10018	0: Off (inactive)	1: On (active)
External Input 19	10019	0: Off (inactive)	1: On (active)
External Input 20	10020	0: Off (inactive)	1: On (active)
External Input 1 Change of state latch	10257	0: Off (inactive)	1: On (active)
External Input 2 Change of state latch	10258	0: Off (inactive)	1: On (active)
External Input 3 Change of state latch	10259	0: Off (inactive)	1: On (active)
External Input 4 Change of state latch	10260	0: Off (inactive)	1: On (active)
External Input 5 Change of state latch	10261	0: Off (inactive)	1: On (active)
External Input 6 Change of state latch	10262	0: Off (inactive)	1: On (active)
External Input 7 Change of state latch	10263	0: Off (inactive)	1: On (active)
External Input 8 Change of state latch	10264	0: Off (inactive)	1: On (active)
External Input 9 Change of state latch	10265	0: Off (inactive)	1: On (active)
External Input 10 Change of state latch	10266	0: Off (inactive)	1: On (active)
External Input 11 Change of state latch	10267	0: Off (inactive)	1: On (active)

Read Input Status (Function Code 02)			
External Input 12 Change of state latch	10268	0: Off (inactive)	1: On (active)
External Input 13 Change of state latch	10269	0: Off (inactive)	1: On (active)
External Input 14 Change of state latch	10270	0: Off (inactive)	1: On (active)
External Input 15 Change of state latch	10271	0: Off (inactive)	1: On (active)
External Input 16 Change of state latch	10272	0: Off (inactive)	1: On (active)
External Input 17 Change of state latch	10273	0: Off (inactive)	1: On (active)
External Input 18 Change of state latch	10274	0: Off (inactive)	1: On (active)
External Input 19 Change of state latch	10275	0: Off (inactive)	1: On (active)
External Input 20 Change of state latch	10276	0: Off (inactive)	1: On (active)
Virtual Input 1	10513	0: Off (inactive)	1: On (active)
Virtual Input 2	10514	0: Off (inactive)	1: On (active)
Virtual Input 3	10515	0: Off (inactive)	1: On (active)
Virtual Input 4	10516	0: Off (inactive)	1: On (active)
Virtual Input 5	10517	0: Off (inactive)	1: On (active)
Virtual Input 6	10518	0: Off (inactive)	1: On (active)
Virtual Input 7	10519	0: Off (inactive)	1: On (active)
Virtual Input 8	10520	0: Off (inactive)	1: On (active)
Virtual Input 9	10521	0: Off (inactive)	1: On (active)
Virtual Input 10	10522	0: Off (inactive)	1: On (active)
Virtual Input 11	10523	0: Off (inactive)	1: On (active)
Virtual Input 12	10524	0: Off (inactive)	1: On (active)
Virtual Input 13	10525	0: Off (inactive)	1: On (active)
Virtual Input 14	10526	0: Off (inactive)	1: On (active)
Virtual Input 15	10527	0: Off (inactive)	1: On (active)
Virtual Input 16	10528	0: Off (inactive)	1: On (active)
Virtual Input 17	10529	0: Off (inactive)	1: On (active)
Virtual Input 18	10530	0: Off (inactive)	1: On (active)
Virtual Input 19	10531	0: Off (inactive)	1: On (active)
Virtual Input 20	10532	0: Off (inactive)	1: On (active)
Virtual Input 21	10533	0: Off (inactive)	1: On (active)
Virtual Input 22	10534	0: Off (inactive)	1: On (active)
Virtual Input 23	10535	0: Off (inactive)	1: On (active)
Virtual Input 24	10536	0: Off (inactive)	1: On (active)
Virtual Input 25	10537	0: Off (inactive)	1: On (active)
Virtual Input 26	10538	0: Off (inactive)	1: On (active)
Virtual Input 27	10539	0: Off (inactive)	1: On (active)
Virtual Input 28	10540	0: Off (inactive)	1: On (active)
Virtual Input 29	10541	0: Off (inactive)	1: On (active)
Virtual Input 30	10542	0: Off (inactive)	1: On (active)

Read Holding Registers (Function Code 03)			
Channel	Address	Units	Scale
L-PRO Clock Time (UTC). Read all in same query to ensure consistent time reading data			
Milliseconds Now * Millisecond information not supported.	40001	0	1
Seconds Now	40002	0-59	1
Minutes Now	40003	0-59	1
Hours Now	40004	0-23	1

Read Holding Registers (Function Code 03)			
Day of Year Now	40005	1-365 (up to 366 if leap year)	1
Years since 1900	40006	90-137	1
Sync'd to IRIG-B	40007	0: No 1: Yes	1
Time of Acquisition (UTC). Read all in same query to ensure consistent time reading data			
Milliseconds Now * Millisecond information not supported.	40008	0	1
Seconds Now	40009	0-59	1
Minutes Now	40010	0-59	1
Hours Now	40011	0-23	1
Day of Year Now	40012	1-365 (up to 366 if leap year)	1
Years since 1900	40013	90-137	1
Sync'd to IRIG-B	40014	0: No 1: Yes	1
Offset of UTC to IED time.	40015	2's complement half hours, North America is negative	1

Channel	Address	Units	Scale
Line Va Magnitude	40257	KV	10
Line Va Angle	40258	Degrees	10
Line Vb Magnitude	40259	KV	10
Line Vb Angle	40260	Degrees	10
Line Vc Magnitude	40261	KV	10
Line Vc Angle	40262	Degrees	10
Line Ia Magnitude	40263	A	1
Line Ia Angle	40264	Degrees	10
Line Ib Magnitude	40265	A	1
Line Ib Angle	40266	Degrees	10
Line Ic Magnitude	40267	A	1
Line Ic Angle	40268	Degrees	10
I2a Magnitude	40269	A	1
I2a Angle	40270	Degrees	10
I2b Magnitude	40271	A	1
I2b Angle	40272	Degrees	10
I2c Magnitude	40273	A	1
I2c Angle	40274	Degrees	10
I3a Magnitude	40275	A	1
I3a Angle	40276	Degrees	10
I3b Magnitude	40277	A	1
I3b Angle	40278	Degrees	10
I3c Magnitude	40279	A	1
I3c Angle	40280	Degrees	10
I4a Magnitude	40281	A	1
I4a Angle	40282	Degrees	10
I4b Magnitude	40283	A	1
I4b Angle	40284	Degrees	10

Channel	Address	Units	Scale
I4c Magnitude	40285	A	1
I4c Angle	40286	Degrees	10
Bus Va Magnitude	40287	KV	10
Bus Va Angle	40288	Degrees	10
Bus Vb Magnitude	40289	KV	10
Bus Vb Angle	40290	Degrees	10
Bus Vc Magnitude	40291	KV	10
Bus Vc Angle	40292	Degrees	10
Not used	40293		
Not used	40294		
Not used	40295		
Not used	40296		
Not used	40297		
Not used	40298		
Not used	40299		
Not used	40300		
Not used	40301		
Not used	40302		
Not used	40303		
Not used	40304		
PosSeq Frequency	40305	Hz	100
P	40306	MW	10
Q	40307	Mvar	10
Pos Seq Voltage	40308	KV	10
Pos Seq Current	40309	A	1
Active Setting Group Number	40310		
Ia summated Magnitude	40311	A	1
Ia summated Angle	40312	degrees	10
Ib summated Magnitude	40313	A	1
Ib summated Angle	40314	degrees	10
Ic summated Magnitude	40315	A	1
Ic summated Angle	40316	degrees	10
Self check fail parameter	40317	N/A	1

Read Input Register (Function Code 04)
No input registers supported. Response from IED indicates "ILLEGAL FUNCTION."

Force Single Coil (Function Code 05)			
Only the "hold readings" coil can be forced. When active, this coil locks all coil, input and holding register readings simultaneously at their present values. When inactive, coil, input and holding register values will read their most recently available state.			
Channel	Type	Address	Value
Hold Readings	Read/Write	01	0000: Readings update normally (inactive) FF00: Hold readings (active)



<b>Preset Single Register (Function Code 06)</b>			
Channel	Address	Value	Scaled Up By
Event Message Control (See below for details of use)			
Refresh event list	40513	No data required	N/A
Acknowledge the current event and get the next event	40514	No data required	N/A
Get the next event (without acknowledge)	40515	No data required	N/A
Event Buffer Size		100	
Self Check Fail Parameter	40317	N/A	1

<b>Diagnostic Subfunctions (Function Code 08)</b>	
Return Query Data (Subfunction 00)	This provides an echo of the submitted message.
Restart Comm. Option (Subfunction 01)	This restarts the Modbus communications process.
Force Listen Only Mode (Subfunction 04)	No response is returned. IED enters "Listen Only" mode. This mode can only be exited by the "Restart Comm. Option" command.

<b>Report Slave ID (Function Code 17/0x11)</b>			
A fixed response is returned by the IED, including system model, version and issue numbers.			
Channel	Type	Bytes	Value
Model Number	Read Only	0 and 1	0 x 0834 = 2100 decimal
Version Number	Read Only	2 and 3	Version number
Issue Number	Read Only	4 and 5	Issue number

- The L-PRO IED model number is 2100.
- Version and issue will each be positive integers, say X and Y.
- The L-PRO is defined as "Model 2100, Version X Issue Y"

<b>Accessing L-PRO Event Information</b>	
All L-PRO detector event messages displayed in the Event Log are available via Modbus. This includes fault location information. The following controls are available.	
Refresh Event List	(Function Code 6, address 40513): Fetches the latest events from the L-PRO's event log and makes them available for Modbus access. The most recent event becomes the current event available for reading.
Acknowledge Current Event and Get Next Event	(Function Code 6, address 40514): Clears the current event from the read registers and places the next event into them. An acknowledged event is no longer available for reading.
Get Next Event	(Function Code 6, address 40515): Places the next event in the read registers without acknowledging the current event. The current event will reappear in the list when Refresh Event List is used.
Size of Current Event Message	(Function Code 3, address 40516): Indicates the number of 16 bit registers used to contain the current event. Event data is stored with 2 characters per register. A reading of zero indicates that there are no unacknowledged events available in the current set. (NB. The Refresh Event List function can be used to check for new events that have occurred since the last Refresh Event List.)
Fault Location Event	(Function Code 3, address 40517): Identifies fault location events. These events are identified by "FL" in this register. Non-fault location events contain "" in this location.
Read Event Message	(Function Code 3, addresses 40518 – 40570): Contains the current message. Two. ASCII characters are packed into each 16 bit register. All unused registers in the set are set to 0.
Fault Information – Type	(Function Code 3, address 40571): If the current event is a fault location event, this register contains the type of fault. The following type bitmap: 0x0001 – Phase A 0x0002 – Phase B 0x0004 – Phase C 0x0008 – Ground Any number of the flags may be set for a given fault. If the relay could not determine the fault type, then the register will not have any flags set and will read 0x0000.
Fault Information – Fault Distance	(Function Code 3, address 40572): If the current event is a fault location event, this register contains the distance to the fault. It is scaled up by a factor of 10. The units are the same as the units set in the relay configuration.
Fault Information – Time of Fault	(Function Code 3, addresses 40573 to 40576): If the current event is a fault location event, these registers contain the time of the fault in seconds since 1970. Each of these 16-bit registers contains an 8-bit portion of a 32-bit time value. Register 40573 contains the upper most 8 bits, and register 40576 contains the lowest 8 bits.

<b>Modbus Event Message Example</b>			
"FL2000Sep21 20:16:16.966 21P1 AB 1.0km: Trip"			
Register	Value		Meaning
	High Byte	Low Byte	
40516	0x00	0x1B	Event text size = 27 (0x1B hex)
40517	0x46	0x4C	'FL' - Fault locator event

<b>Modbus Event Message Example</b>			
"FL2000Sep21 20:16:16.966 21P1 AB 1.0km: Trip"			
<b>Register</b>	<b>Value</b>		<b>Meaning</b>
40518	0x32	0x30	'2', '0'
40519	0x30	0x30	'0', '0'
40520	0x53	0x65	'S', 'e'
40521	0x70	0x32	'p', '2'
40522	0x31	0x20	'1', '<sp>'
40523	0x32	0x30	'2', '0'
40524	0x3A	0x31	':', '1'
40525	0x36	0x3A	'6', ':'
40526	0x31	0x36	'1', '6'
40527	0x2E	0x39	':', '9'
40528	0x36	0x36	'6', '6'
40529	0x20	0x32	'<sp>', '2'
40530	0x31	0x50	'1', 'P'
40531	0x31	0x20	'1', '<sp>'
40532	0x41	0x42	'A', 'B'
40533	0x20	0x31	'<sp>', '1'
40534	0x2E	0x30	':', '0'
40535	0x6B	0x6D	'K', 'm'
40536	0x3A	0x20	':', '<sp>'
40537	0x54	0x72	'T', 'r'
40538	0x69	0x70	'i', 'p'



# Appendix F DNP3 Device Profile

## Device Properties

Unless otherwise noted, multiple boxes in the second column below should be selected for each parameter to indicate all capabilities supported or required. Parameters without checkboxes in the second column do not have capabilities and are included so the current value may be shown in the third column.

The items listed in the capabilities column below may be configurable to any of the options selected, or set to a fixed value when the device was designed. Item 1.1.10 contains a list of abbreviations for the possible ways in which the configurable parameters may be set. Since some parameters may not be accessible by each of these methods supported, an abbreviation for the configuration methods supported by each parameter is shown in the fourth column of the tables below.

This document may be used to show the device capabilities, the current value of each parameter, or both. If it is used to show the current values, the third column should be filled in even if a fixed parameter is selected in the capabilities section ("NA" may be entered for parameters that are Not Applicable).

If this document is used to show the current value of each parameter, the "Current Value" column applies to a single connection between a master and outstation.

1.1 Device Identification	Capabilities	Current Value	If configurable, list methods
1.1.1 Device Function:	<input type="checkbox"/> Master <input type="checkbox"/> Outstation	<input type="checkbox"/> Master <input type="checkbox"/> Outstation	
1.1.2 Vendor Name:		NxtPhase T&D Corporation	
1.1.3 Device Name:		L-PRO 2100	
1.1.4 Device manufacturer's hardware version string:		NA	
1.1.5 Device manufacturer's software version string:		NA	
1.1.6 Device Profile Document Version Number:		V1.0, October 26, 2007	
1.1.7 DNP Levels Supported for:	Masters Only RequestsResponses <input type="checkbox"/> None <input type="checkbox"/> Level 1 <input type="checkbox"/> Level 2 <input type="checkbox"/> Level 3  Outstations Only Requests and Responses <input type="checkbox"/> None <input type="checkbox"/> Level 1 <input checked="" type="checkbox"/> Level 2 <input type="checkbox"/> Level 3		

1.1 Device Identification	Capabilities	Current Value	If configurable, list methods
1.1.8 Supported Function Blocks:	<input type="checkbox"/> Self-Address Reservation <input type="checkbox"/> Object 0 - attribute objects <input type="checkbox"/> Data Sets <input type="checkbox"/> File Transfer <input type="checkbox"/> Virtual Terminal <input type="checkbox"/> Mapping to IEC 61850 Object Models defined in a DNP3 XML file		
1.1.9 Notable Additions:	<ul style="list-style-type: none"> <li>• Start-stop (qualifier codes 0x00 and 0x01), limited quantity (qualifier codes 0x07 and 0x08) and indices (qualifier codes 0x17 and 0x28) for Binary Inputs, Binary Outputs and Analog Inputs (object groups 1, 10 and 30)</li> <li>• 32-bit and 16-bit Analog Inputs with and without flag (variations 1, 2, 3 and 4)</li> <li>• Analog Input events with time (variations 3 and 4)</li> <li>• Fault Location information as analog readings</li> <li>• Event Log messages as Object groups 110 and 111</li> </ul>		
1.1.10 Methods to set Configurable Parameters:	<input type="checkbox"/> XML - Loaded via DNP3 File Transfer <input type="checkbox"/> XML - Loaded via other transport mechanism <input type="checkbox"/> Terminal - ASCII Terminal Command Line <input checked="" type="checkbox"/> Software - Vendor software named <u>L-PRO Offliner</u> <input type="checkbox"/> Proprietary file loaded via DNP3 file transfer <input type="checkbox"/> Proprietary file loaded via other transport mechanism <input type="checkbox"/> Direct - Keypad on device front panel <input type="checkbox"/> Factory - Specified when device is ordered <input type="checkbox"/> Protocol - Set via DNP3 (e.g. assign class) <input type="checkbox"/> Other - explain _____		
1.1.11 DNP3 XML files available On-Line:	<p>RdWrFilenameDescription of Contents</p> <input type="checkbox"/> dnpDP.xml Complete Device Profile <input type="checkbox"/> dnpDPcap.xml Device Profile Capabilities <input type="checkbox"/> dnpDPcfg.xml Device Profile config. values <input type="checkbox"/> _____*.xml _____ <p>*The Complete Device Profile Document contains the capabilities, Current Value, and configurable methods columns.                      *The Device Profile Capabilities contains only the capabilities and configurable methods columns.                      *The Device Profile Config. Values contains only the Current Value column.</p>	Not supported	

1.1 Device Identification	Capabilities	Current Value	If configurable, list methods
1.1.12 External DNP3 XML files available Off-line:	Rd                                      WrFilenameDescription of Contents <input type="checkbox"/> <input type="checkbox"/> dnpDP.xml      Complete Device Profile <input type="checkbox"/> <input type="checkbox"/> dnpDPcap.xml Device Profile Capabilities <input type="checkbox"/> <input type="checkbox"/> dnpDPcfg.xml Device Profile config. values <input type="checkbox"/> <input type="checkbox"/> _____*.xml _____  *The Complete Device Profile Document contains the capabilities, Current Value, and configurable methods columns. *The Device Profile Capabilities contains only the capabilities and configurable methods columns. *The Device Profile Config. Values contains only the Current Value column.	Not supported	
1.1.13 Connections Supported:	<input checked="" type="checkbox"/> Serial (complete section 1.2) <input checked="" type="checkbox"/> IP Networking (complete section 1.3) <input type="checkbox"/> Other, explain _____		

1.2 Serial Connections	Capabilities	Current Value	If configurable, list methods
1.2.1 Port Name	Port 3		
1.2.2 Serial Connection Parameters:	<input type="checkbox"/> Asynchronous - 8 Data Bits, 1 Start Bit, 1 Stop Bit, No Parity <input checked="" type="checkbox"/> Other, explain - <u>Asynchronous with selectable parity</u>	Not configured for DNP	L-PRO Offliner
1.2.3 Baud Rate:	<input type="checkbox"/> Fixed at _____ <input type="checkbox"/> Configurable, range _____ to _____ <input checked="" type="checkbox"/> Configurable, selectable from 300, 1200, 2400, 9600, 19200, 38400 and 57600 <input type="checkbox"/> Configurable, other, describe _____	Not configured for DNP	L-PRO Offliner
1.2.4 Hardware Flow Control (Handshaking): Describe hardware signaling requirements of the interface. Where a transmitter or receiver is inhibited until a given control signal is asserted, it is considered to require that signal prior to sending or receiving characters. Where a signal is asserted prior to transmitting, that signal will be maintained active until after the end of transmission. Where a signal is asserted to enable reception, any data sent to the device when the signal is not active could be discarded.	<input type="checkbox"/> None <b>RS-232 / V.24 / V.28 Options:</b> Before Tx, Asserts: <input type="checkbox"/> RTS <input type="checkbox"/> DTR Before Rx, Asserts: <input type="checkbox"/> RTS <input type="checkbox"/> DTR Always Asserts: <input checked="" type="checkbox"/> RTS <input checked="" type="checkbox"/> DTR Before Tx, Requires: AssertedDeasserted <input type="checkbox"/> CTS <input type="checkbox"/> DCD <input type="checkbox"/> DSR <input type="checkbox"/> RI <input type="checkbox"/> Rx Inactive Before Rx, Requires: AssertedDeasserted <input type="checkbox"/> CTS <input type="checkbox"/> DCD <input type="checkbox"/> DSR <input type="checkbox"/> RI Always Ignores: <input checked="" type="checkbox"/> CTS <input checked="" type="checkbox"/> DCD <input checked="" type="checkbox"/> DSR <input checked="" type="checkbox"/> RI  <input type="checkbox"/> Other, explain _____ <b>RS-422 / V.11 Options:</b> <input type="checkbox"/> Requires Indication before Rx <input type="checkbox"/> Asserts Control before Tx <input type="checkbox"/> Other, explain _____ <b>RS-485 Options:</b> <input type="checkbox"/> Requires Rx inactive before Tx <input type="checkbox"/> Other, explain _____		
1.2.5 Interval to Request Link Status:	<input checked="" type="checkbox"/> Not Supported <input type="checkbox"/> Fixed at _____ seconds <input type="checkbox"/> Configurable, range _____ to _____ seconds <input type="checkbox"/> Configurable, selectable from __, __, __ seconds <input type="checkbox"/> Configurable, other, describe _____		
1.2.6 Supports DNP3 Collision Avoidance:	<input checked="" type="checkbox"/> No <input type="checkbox"/> Yes, explain _____		



1.2 Serial Connections	Capabilities	Current Value	If configurable, list methods
1.2.7 Receiver Inter-character Timeout:	<input checked="" type="checkbox"/> Not checked <input type="checkbox"/> No gap permitted <input type="checkbox"/> Fixed at _____ bit times <input type="checkbox"/> Fixed at _____ ms <input type="checkbox"/> Configurable, range _____ to _____ bit times <input type="checkbox"/> Configurable, range _____ to _____ ms <input type="checkbox"/> Configurable, Selectable from __, __, __ bit times <input type="checkbox"/> Configurable, Selectable from __, __, __ ms <input type="checkbox"/> Configurable, other, describe _____ <input type="checkbox"/> Variable, explain _____		
1.2.8 Inter-character gaps in transmission:	<input checked="" type="checkbox"/> None (always transmits with no inter-character gap) <input type="checkbox"/> Maximum _____ bit times <input type="checkbox"/> Maximum _____ ms		

1.3 IP Networking	Capabilities	Current Value	If configurable, list methods
1.3.1 Port Name	Port 5 Network		
1.3.2 Type of End Point:	<input type="checkbox"/> TCP Initiating (Master Only) <input checked="" type="checkbox"/> TCP Listening (Outstation Only) <input type="checkbox"/> TCP Dual (required for Masters) <input checked="" type="checkbox"/> UDP Datagram (required)	Not configured for DNP	L-PRO Offliner
1.3.3 IP Address of this Device:		192.168.100.101	L-PRO Maintenance utilities
1.3.4 Subnet Mask:		Not set	L-PRO Maintenance utilities
1.3.5 Gateway IP Address:		Not set	L-PRO Maintenance utilities
1.3.6 Accepts TCP Connections or UDP Datagrams from:	<input checked="" type="checkbox"/> Allows all (show as *.*.* in 1.3.7) <input checked="" type="checkbox"/> Limits based on an IP address <input checked="" type="checkbox"/> Limits based on list of IP addresses <input type="checkbox"/> Limits based on a wildcard IP address <input type="checkbox"/> Limits based on list of wildcard IP addresses <input type="checkbox"/> Other validation, explain _____	Limits based on an IP address	L-PRO Offliner
1.3.7 IP Address(es) from which TCP Connections or UDP Datagrams are accepted:		192.168.1.1	L-PRO Offliner
1.3.8 TCP Listen Port Number:	<input type="checkbox"/> Not Applicable (Master w/o dual end point) <input type="checkbox"/> Fixed at 20,000 <input checked="" type="checkbox"/> Configurable, range <u>1025</u> to <u>32737</u> <input type="checkbox"/> Configurable, selectable from _____,_____,_____ <input type="checkbox"/> Configurable, other, describe _____	20,000	L-PRO Offliner
1.3.9 TCP Listen Port Number of remote device:	<input checked="" type="checkbox"/> Not Applicable (Outstation w/o dual end point) <input type="checkbox"/> Fixed at 20,000 <input type="checkbox"/> Configurable, range _____ to _____ <input type="checkbox"/> Configurable, selectable from _____,_____,_____ <input type="checkbox"/> Configurable, other, describe _____	NA	
1.3.10 TCP Keep-alive timer:	<input type="checkbox"/> Fixed at _____ms <input checked="" type="checkbox"/> Configurable, range <u>5</u> to <u>3,600</u> s <input type="checkbox"/> Configurable, selectable from _____,_____,_____ <input type="checkbox"/> Configurable, other, describe _____	Disabled	L-PRO Offliner
1.3.11 Local UDP port:	<input type="checkbox"/> Fixed at 20,000 <input checked="" type="checkbox"/> Configurable, range <u>1025</u> to <u>32737</u> <input type="checkbox"/> Configurable, selectable from _____,_____,_____ <input type="checkbox"/> Configurable, other, describe _____ <input type="checkbox"/> Let system choose (Master only)	20,000	L-PRO Offliner
1.3.12 Destination UDP port for DNP3 Requests (Master Only):		NA	
1.3.13 Destination UDP port for initial unsolicited null responses (UDP only Outstations):	<input checked="" type="checkbox"/> None <input type="checkbox"/> Fixed at 20,000 <input type="checkbox"/> Configurable, range _____ to _____ <input type="checkbox"/> Configurable, selectable from _____,_____,_____ <input type="checkbox"/> Configurable, other, describe _____	NA	

1.3 IP Networking	Capabilities	Current Value	If configurable, list methods
1.3.14 Destination UDP port for responses:	<input type="checkbox"/> None <input type="checkbox"/> Fixed at 20,000 <input checked="" type="checkbox"/> Configurable, range <u>1025</u> to <u>32737</u> <input type="checkbox"/> Configurable, selectable from _____,_____,_____ <input type="checkbox"/> Configurable, other, describe _____ <input type="checkbox"/> Use source port number	20,000	L-PRO Offliner
1.3.15 Multiple master connections (Outstations Only):	<input checked="" type="checkbox"/> Supports multiple masters (Outstations only) If supported, the following methods may be used: <input checked="" type="checkbox"/> Method 1 (based on IP address) - required <input checked="" type="checkbox"/> Method 2 (based on IP port number) - recommended <input checked="" type="checkbox"/> Method 3 (browsing for static data) - optional	Method 1 (based on IP address)	L-PRO Offliner
1.3.16 Time synchronization support:	<input type="checkbox"/> DNP3 LAN procedure (function code 24) <input type="checkbox"/> DNP3 Write Time (not recommended over LAN) <input type="checkbox"/> Other, explain _____ <input checked="" type="checkbox"/> Not Supported		

1.4 Link Layer	Capabilities	Current Value	If configurable, list methods
1.4.1 Data Link Address:	<input type="checkbox"/> Fixed at _____ <input checked="" type="checkbox"/> Configurable, range <u>1</u> to <u>65519</u> <input type="checkbox"/> Configurable, selectable from _____,_____,_____ <input type="checkbox"/> Configurable, other, describe _____	1	L-PRO Offliner
1.4.2 DNP3 Source Address Validation:	<input checked="" type="checkbox"/> Never <input type="checkbox"/> Always, one address allowed (shown in 1.4.3) <input type="checkbox"/> Always, any one of multiple addresses allowed (each selectable as shown in 1.4.3) <input type="checkbox"/> Sometimes, explain _____		
1.4.3 DNP3 Source Address(es) expected when Validation is Enabled:	<input type="checkbox"/> Configurable to any 16 bit DNP Data Link Address value <input type="checkbox"/> Configurable, range _____ to _____ <input type="checkbox"/> Configurable, selectable from _____,_____,_____ <input type="checkbox"/> Configurable, other, describe _____	NA	
1.4.4 Self Address Support using address 0xFFFC:	<input type="checkbox"/> Yes (only allowed if configurable) <input checked="" type="checkbox"/> No	NA	
1.4.5 Sends Confirmed User Data Frames:	<input type="checkbox"/> Always <input type="checkbox"/> Sometimes, explain _____ <input type="checkbox"/> Never <input checked="" type="checkbox"/> Configurable, either always or never		L-PRO Offliner (to disable, set Data Link Timeout to 0)
1.4.6 Data Link Layer Confirmation Timeout:	<input type="checkbox"/> None <input checked="" type="checkbox"/> Fixed at <u>2,000</u> ms <input type="checkbox"/> Configurable, range _____ to _____ ms <input type="checkbox"/> Configurable, selectable from _____,_____,_____ <input type="checkbox"/> Configurable, other, describe _____ <input type="checkbox"/> Variable, explain _____	2,000	
1.4.7 Maximum Data Link Retries:	<input type="checkbox"/> Never Retries <input checked="" type="checkbox"/> Fixed at <u>3</u> <input type="checkbox"/> Configurable, range _____ to _____ <input type="checkbox"/> Configurable, selectable from _____,_____,_____ <input type="checkbox"/> Configurable, other, describe _____	3	
1.4.8 Maximum number of octets Transmitted in a Data Link Frame:	<input checked="" type="checkbox"/> Fixed at <u>292</u> <input type="checkbox"/> Configurable, range _____ to _____ <input type="checkbox"/> Configurable, selectable from _____,_____,_____ <input type="checkbox"/> Configurable, other, describe _____	292	
1.4.9 Maximum number of octets that can be Received in a Data Link Frame:	<input checked="" type="checkbox"/> Fixed at <u>292</u> <input type="checkbox"/> Configurable, range _____ to _____ <input type="checkbox"/> Configurable, selectable from _____,_____,_____ <input type="checkbox"/> Configurable, other, describe _____	292	

1.5 Application Layer	Capabilities	Current Value	If configurable, list methods
1.5.1 Maximum number of octets Transmitted in an Application Layer Fragment other than File Transfer:	<input checked="" type="checkbox"/> Fixed at 2048 <input type="checkbox"/> Configurable, range _____ to _____ <input type="checkbox"/> Configurable, selectable from ____, ____, ____ <input type="checkbox"/> Configurable, other, describe _____	2048	
1.5.2 Maximum number of octets Transmitted in an Application Layer Fragment containing File Transfer:	<input type="checkbox"/> Fixed at _____ <input type="checkbox"/> Configurable, range _____ to _____ <input type="checkbox"/> Configurable, selectable from ____, ____, ____ <input type="checkbox"/> Configurable, other, describe _____	NA	
1.5.3 Maximum number of octets that can be Received in an Application Layer Fragment:	<input checked="" type="checkbox"/> Fixed at 2048 <input type="checkbox"/> Configurable, range _____ to _____ <input type="checkbox"/> Configurable, selectable from ____, ____, ____ <input type="checkbox"/> Configurable, other, describe _____	2048	
1.5.4 Timeout waiting for Complete Application Layer Fragment:	<input type="checkbox"/> None <input checked="" type="checkbox"/> Fixed at <u>2,000</u> ms <input type="checkbox"/> Configurable, range _____ to _____ms <input type="checkbox"/> Configurable, selectable from ____, ____, ____ms <input type="checkbox"/> Configurable, other, describe _____ <input type="checkbox"/> Variable, explain _____	2,000 ms	
1.5.5 Maximum number of objects allowed in a single control request for CROB (group 12):	<input checked="" type="checkbox"/> Fixed at <u>16</u> <input type="checkbox"/> Configurable, range _____ to _____ <input type="checkbox"/> Configurable, selectable from ____, ____, ____ <input type="checkbox"/> Configurable, other, describe _____ <input type="checkbox"/> Variable, explain _____	16	
1.5.6 Maximum number of objects allowed in a single control request for Analog Outputs (group 41):	<input type="checkbox"/> Fixed at _ <input type="checkbox"/> Configurable, range _____ to _____ <input type="checkbox"/> Configurable, selectable from ____, ____, ____ <input type="checkbox"/> Configurable, other, describe _____ <input type="checkbox"/> Variable, explain _____	Analog Outputs not supported	
1.5.7 Maximum number of objects allowed in a single control request for Data Sets (groups 85,86,87):	<input type="checkbox"/> Fixed at _ <input type="checkbox"/> Configurable, range _____ to _____ <input type="checkbox"/> Configurable, selectable from ____, ____, ____ <input type="checkbox"/> Configurable, other, describe _____ <input type="checkbox"/> Variable, explain _____	Data Sets not supported	
1.5.8 Supports mixing object groups (AOBs, CROBs and Data Sets) in the same control request:	<input type="checkbox"/> Not applicable - controls are not supported <input type="checkbox"/> Yes <input checked="" type="checkbox"/> No	Analog Outputs not supported	

1.6 Fill Out The Following Items For Outstations Only	Capabilities	Current Value	If configurable, list methods
1.6.1 Timeout waiting for Application Confirm of solicited response message:	<input type="checkbox"/> None <input checked="" type="checkbox"/> Fixed at <u>5,000</u> ms <input type="checkbox"/> Configurable, range _____ to _____ ms <input type="checkbox"/> Configurable, selectable from ____, ____, ____ ms <input type="checkbox"/> Configurable, other, describe _____ <input type="checkbox"/> Variable, explain _____	5,000 ms	
1.6.2 How often is time synchronization required from the master?	<input checked="" type="checkbox"/> Never needs time <input type="checkbox"/> Within _____ seconds after IIN1.4 is set <input type="checkbox"/> Periodically every _____ seconds		
1.6.3 Device Trouble Bit IIN1.6:	<input type="checkbox"/> Never used <input checked="" type="checkbox"/> Reason for setting: <u>Unable to access requested data or execute CROB, assuming a valid request has been received</u>		
1.6.4 File Handle Timeout:	<input checked="" type="checkbox"/> Not applicable, files not supported <input type="checkbox"/> Fixed at _____ ms <input type="checkbox"/> Configurable, range _____ to _____ ms <input type="checkbox"/> Configurable, selectable from ____, ____, ____ ms <input type="checkbox"/> Configurable, other, describe _____ <input type="checkbox"/> Variable, explain _____		
1.6.5 Event Buffer Overflow Behaviour:	<input type="checkbox"/> Discard the oldest event <input checked="" type="checkbox"/> Discard the newest event <input type="checkbox"/> Other, explain _____		
1.6.6 Event Buffer Organization:	<ul style="list-style-type: none"> <li>• Single buffer for the Object Groups 2 and 32, size 200.</li> <li>• Separate buffer for the Object Group 111, size 100.</li> <li>• Separate buffer for the Fault Locator events, size 100.</li> </ul>		
1.6.7 Sends Multi-Fragment Responses:	<input checked="" type="checkbox"/> Yes <input type="checkbox"/> No		
1.6.8 DNP Command Settings preserved through a device reset:	<input type="checkbox"/> Assign Class <input type="checkbox"/> Analog Deadbands <input type="checkbox"/> Data Set Prototypes <input type="checkbox"/> Data Set Descriptors	Not supported	

---

<b>1.7 Outstation Unsolicited Response Support</b>	<b>Capabilities</b>	<b>Current Value</b>	<b>If configurable, list methods</b>
1.7.1 Supports Unsolicited Reporting:	<input checked="" type="checkbox"/> Not Supported <input type="checkbox"/> Configurable, selectable from On and Off	NA	

1.8 Outstation Performance	Capabilities	Current Value	If configurable, list methods
1.8.1 Maximum Time Base Drift (milliseconds per minute):		NA, not synchronized by DNP	
1.8.2 When does outstation set IIN1.4?	<input checked="" type="checkbox"/> Never <input type="checkbox"/> Asserted at startup until first Time Synchronization request received <input type="checkbox"/> Periodically, range ____ to ____ seconds <input type="checkbox"/> Periodically, selectable from ____, ____, ____ seconds <input type="checkbox"/> Range ____ to ____ seconds after last time sync <input type="checkbox"/> Selectable from ____, ____, ____ seconds after last time sync <input type="checkbox"/> When time error may have drifted by range ____ to ____ ms <input type="checkbox"/> When time error may have drifted by selectable from ____, ____, ____	NA	
1.8.3 Maximum Internal Time Reference Error when set via DNP (ms):		NA	
1.8.4 Maximum Delay Measurement error (ms):		NA	
1.8.5 Maximum Response time (ms):		100 ms (for the case all supported points mapped to the DNP point lists)	L-PRO Offliner
1.8.6 Maximum time from start-up to IIN 1.4 assertion (ms):		NA	
1.8.7 Maximum Event Time-tag error for local Binary and Double-bit I/O (ms):		<ul style="list-style-type: none"> <li>• 0.1736 ms for 60Hz systems</li> <li>• 0.2083 ms for 50 Hz systems</li> </ul>	
1.8.8 Maximum Event Time-tag error for local I/O other than Binary and Double-bit data types (ms):		<ul style="list-style-type: none"> <li>• 0.1736 ms for 60Hz systems</li> <li>• 0.2083 ms for 50 Hz systems</li> </ul>	



## Capabilities and Current Settings for Device Database (Outstation Only)

The following tables identify the capabilities and current settings for each DNP3 data type. Each data type also provides a table defining the data points available in the device or a description of how this information can be obtained if the database is configurable.

2.1 Single-Bit Binary Inputs Static (Steady-State) Group Number: 1 Event Group Number: 2	Capabilities	Current Value	If configurable, list methods
2.1.1 Static Variation reported when variation 0 requested:	<input checked="" type="checkbox"/> Variation 1 - Single-bit Packed format <input type="checkbox"/> Variation 2 - Single-bit with flag <input type="checkbox"/> Based on point Index (add column to table below)		
2.1.2 Event Variation reported when variation 0 requested:	<input type="checkbox"/> Variation 1 - without time <input checked="" type="checkbox"/> Variation 2 - with absolute time <input type="checkbox"/> Variation 3 - with relative time <input type="checkbox"/> Based on point Index (add column to table below)		
2.1.3 Event reporting mode:	<input type="checkbox"/> Only most recent <input checked="" type="checkbox"/> All events		
2.1.4 Binary Inputs included in Class 0 response:	<input checked="" type="checkbox"/> Always <input type="checkbox"/> Never <input type="checkbox"/> Only if point is assigned to Class 1, 2, or 3 <input type="checkbox"/> Based on point Index (add column to table below)		L-PRO Offliner
2.1.5 Definition of Binary Input Point List:	<input type="checkbox"/> Fixed, list shown in table below <input checked="" type="checkbox"/> Configurable <input type="checkbox"/> Other, explain _____	Default list is shown in the table below	L-PRO Offliner

<b>NOTES</b>	<p>1. Binary Inputs are scanned with 1 ms resolution.</p> <p>2. Binary Input data points are user selectable; the data points available in the device for any given Binary Input point selection can be obtained through the L-PRO Offliner software (see SCADA Setting Summary).</p>
--------------	---

Point Index	Name	Default Class Assigned to Events (1, 2, 3 or none)	Name for State when value is 0	Name for State when value is 1	Description
0	External Input 1	1	Inactive	Active	
1	External Input 2	1	Inactive	Active	
2	External Input 3	1	Inactive	Active	
3	External Input 4	1	Inactive	Active	
4	External Input 5	1	Inactive	Active	
5	External Input 6	1	Inactive	Active	

Point Index	Name	Default Class Assigned to Events (1, 2, 3 or none)	Name for State when value is 0	Name for State when value is 1	Description
6	External Input 7	1	Inactive	Active	
7	External Input 8	1	Inactive	Active	
8	External Input 9	1	Inactive	Active	
9	Virtual Input 1	1	Inactive	Active	
10	Virtual Input 2	1	Inactive	Active	
11	Virtual Input 3	1	Inactive	Active	
12	Virtual Input 4	1	Inactive	Active	
13	Virtual Input 5	1	Inactive	Active	
14	Virtual Input 6	1	Inactive	Active	
15	Virtual Input 7	1	Inactive	Active	
16	Virtual Input 8	1	Inactive	Active	
17	Virtual Input 9	1	Inactive	Active	
18	Virtual Input 10	1	Inactive	Active	
19	Virtual Input 11	1	Inactive	Active	
20	Virtual Input 12	1	Inactive	Active	
21	Virtual Input 13	1	Inactive	Active	
22	Virtual Input 14	1	Inactive	Active	
23	Virtual Input 15	1	Inactive	Active	
24	Virtual Input 16	1	Inactive	Active	
25	Virtual Input 17	1	Inactive	Active	
26	Virtual Input 18	1	Inactive	Active	
27	Virtual Input 19	1	Inactive	Active	
28	Virtual Input 20	1	Inactive	Active	
29	Virtual Input 21	1	Inactive	Active	
30	Virtual Input 22	1	Inactive	Active	
31	Virtual Input 23	1	Inactive	Active	
32	Virtual Input 24	1	Inactive	Active	
33	Virtual Input 25	1	Inactive	Active	
34	Virtual Input 26	1	Inactive	Active	
35	Virtual Input 27	1	Inactive	Active	
36	Virtual Input 28	1	Inactive	Active	
37	Virtual Input 29	1	Inactive	Active	
38	Virtual Input 30	1	Inactive	Active	

<b>Point Index</b>	<b>Name</b>	<b>Default Class Assigned to Events (1, 2, 3 or none)</b>	<b>Name for State when value is 0</b>	<b>Name for State when value is 1</b>	<b>Description</b>
39	Fault Information Available	1	Inactive	Active	
40	External Input 10	1	Inactive	Active	
41	External Input 11	1	Inactive	Active	
42	External Input 12	1	Inactive	Active	
43	External Input 13	1	Inactive	Active	
44	External Input 14	1	Inactive	Active	
45	External Input 15	1	Inactive	Active	
46	External Input 16	1	Inactive	Active	
47	External Input 17	1	Inactive	Active	
48	External Input 18	1	Inactive	Active	
49	External Input 19	1	Inactive	Active	
50	External Input 20	1	Inactive	Active	

<b>2.2 Binary Output Status And Control Relay Output Block</b> Binary Output Status Group Number: 10 Binary Output Event Group Number: 11 CROB Group Number: 12 Binary Output Command Event Object Num: 13	<b>Capabilities</b>	<b>Current Value</b>	<b>If configurable, list methods</b>
2.2.1 Minimum pulse time allowed with Trip, Close, and Pulse On commands:	<input checked="" type="checkbox"/> Fixed at <u>0.000</u> ms (hardware may limit this further) <input type="checkbox"/> Based on point Index (add column to table below)		
2.2.2 Maximum pulse time allowed with Trip, Close, and Pulse On commands:	<input checked="" type="checkbox"/> Fixed at <u>0.000</u> ms (hardware may limit this further) <input type="checkbox"/> Based on point Index (add column to table below)		
2.2.3 Binary Output Status included in Class 0 response:	<input checked="" type="checkbox"/> Always <input type="checkbox"/> Never <input type="checkbox"/> Only if point is assigned to Class 1, 2, or 3 <input type="checkbox"/> Based on point Index (add column to table below)		
2.2.4 Reports Output Command Event Objects:	<input checked="" type="checkbox"/> Never <input type="checkbox"/> Only upon a successful Control <input type="checkbox"/> Upon all control attempts	Not supported	
2.2.5 Event Variation reported when variation 0 requested:	<input type="checkbox"/> Variation 1 - without time <input type="checkbox"/> Variation 2 - with absolute time <input type="checkbox"/> Based on point Index (add column to table below)	Not supported	L-PRO Offliner (See Note 2 below)
2.2.6 Command Event Variation reported when variation 0 requested:	<input type="checkbox"/> Variation 1 - without time <input type="checkbox"/> Variation 2 - with absolute time <input type="checkbox"/> Based on point Index (add column to table below)	Not supported	L-PRO Offliner (See Note 2 below)
2.2.7 Event reporting mode:	<input type="checkbox"/> Only most recent <input type="checkbox"/> All events	Not supported	L-PRO Offliner (See Note 2 below)
2.2.8 Command Event reporting mode:	<input type="checkbox"/> Only most recent <input type="checkbox"/> All events	Not supported	
2.2.9 Maximum Time between Select and Operate:	<input type="checkbox"/> Not Applicable <input checked="" type="checkbox"/> Fixed at <u>10</u> seconds <input type="checkbox"/> Configurable, range _____ to _____ seconds <input type="checkbox"/> Configurable, selectable from _____, _____ seconds <input type="checkbox"/> Configurable, other, describe _____ <input type="checkbox"/> Variable, explain _____ <input type="checkbox"/> Based on point Index (add column to table below)	10 s	
2.2.10 Definition of Binary Output Status/Control relay output block (CROB) Point List:	<input type="checkbox"/> Fixed, list shown in table below <input checked="" type="checkbox"/> Configurable <input type="checkbox"/> Other, explain _____	Default list is shown in the table below	L-PRO Offliner

- NOTES**
- Binary Outputs are scanned with 500 ms resolution.
  - Events are not supported for Binary Outputs (group 10), but most of Binary Output points can be mapped to Binary Inputs (group 2) with full Event and Class Data support. See L-PRO Offliner/DNP Configuration/Point Map screen for complete point lists and configuration options.
  - Virtual Inputs (default Binary Output points 94-123) can be used to control relay output contacts. See L-PRO Offliner/Setting Group X/Output Matrix screen for configuration options.
  - Binary Output data points are user selectable; the data points available in the device for any given Binary Output point selection can be obtained through the L-PRO Offliner software (see SCADA Setting Summary).

Point Index	Name	Supported Control Operations											Name for State when value is 0	Name for State when value is 1	Default Class Assigned to Events (1, 2, 3 or none)		Description
		Select/Operate	Direct Operate	Direct Operate - No Ack	Pulse On / NUL	Pulse Off	Latch On / NUL	Latch Off / NUL	Trip	Close	Count > 1	Cancel Currently Running Operation			Change	Command	
0	Output contact 1	-	-	-	-	-	-	-	-	-	-	-	Open	Closed	None	None	
1	Output contact 2	-	-	-	-	-	-	-	-	-	-	-	Open	Closed	None	None	
2	Output contact 3	-	-	-	-	-	-	-	-	-	-	-	Open	Closed	None	None	
3	Output contact 4	-	-	-	-	-	-	-	-	-	-	-	Open	Closed	None	None	
4	Output contact 5	-	-	-	-	-	-	-	-	-	-	-	Open	Closed	None	None	
5	Output contact 6	-	-	-	-	-	-	-	-	-	-	-	Open	Closed	None	None	
6	Output contact 7	-	-	-	-	-	-	-	-	-	-	-	Open	Closed	None	None	
7	Output contact 8	-	-	-	-	-	-	-	-	-	-	-	Open	Closed	None	None	
8	Output contact 9	-	-	-	-	-	-	-	-	-	-	-	Open	Closed	None	None	
9	Output contact 10	-	-	-	-	-	-	-	-	-	-	-	Open	Closed	None	None	
10	Output contact 11	-	-	-	-	-	-	-	-	-	-	-	Open	Closed	None	None	
11	Output contact 12	-	-	-	-	-	-	-	-	-	-	-	Open	Closed	None	None	
12	Output contact 13	-	-	-	-	-	-	-	-	-	-	-	Open	Closed	None	None	
13	Output contact 14	-	-	-	-	-	-	-	-	-	-	-	Open	Closed	None	None	
14	21P1 Trip	-	-	-	-	-	-	-	-	-	-	-	Inactive	Active	None	None	
15	21P2 Trip	-	-	-	-	-	-	-	-	-	-	-	Inactive	Active	None	None	
16	21P3 Trip	-	-	-	-	-	-	-	-	-	-	-	Inactive	Active	None	None	
17	21P4 Trip	-	-	-	-	-	-	-	-	-	-	-	Inactive	Active	None	None	
18	51 Trip	-	-	-	-	-	-	-	-	-	-	-	Inactive	Active	None	None	
19	50 Trip	-	-	-	-	-	-	-	-	-	-	-	Inactive	Active	None	None	
20	21N1 Trip	-	-	-	-	-	-	-	-	-	-	-	Inactive	Active	None	None	
21	21N2 Trip	-	-	-	-	-	-	-	-	-	-	-	Inactive	Active	None	None	

Appendix F DNP3 Device Profile

Point Index	Name	Supported Control Operations											Name for State when value is 0	Name for State when value is 1	Default Class Assigned to Events (1, 2, 3 or none)		Description
		Select/Operate	Direct Operate	Direct Operate - No Ack	Pulse On / NUL	Pulse Off	Latch On / NUL	Latch Off / NUL	Trip	Close	Count > 1	Cancel Currently Running Operation			Change	Command	
22	21N3 Trip	-	-	-	-	-	-	-	-	-	-	-	Inactive	Active	None	None	
23	21N4 Trip	-	-	-	-	-	-	-	-	-	-	-	Inactive	Active	None	None	
24	68 Out of Step	-	-	-	-	-	-	-	-	-	-	-	Inactive	Active	None	None	
25	Zcircle Trigger	-	-	-	-	-	-	-	-	-	-	-	Inactive	Active	None	None	
26	51N Trip	-	-	-	-	-	-	-	-	-	-	-	Inactive	Active	None	None	
27	50N Trip	-	-	-	-	-	-	-	-	-	-	-	Inactive	Active	None	None	
28	46-51 Trip	-	-	-	-	-	-	-	-	-	-	-	Inactive	Active	None	None	
29	46-50 Trip	-	-	-	-	-	-	-	-	-	-	-	Inactive	Active	None	None	
30	Deadline Trip	-	-	-	-	-	-	-	-	-	-	-	Inactive	Active	None	None	
31	Comm Scheme Trip	-	-	-	-	-	-	-	-	-	-	-	Inactive	Active	None	None	
32	Comm Scheme Send	-	-	-	-	-	-	-	-	-	-	-	Inactive	Active	None	None	
33	60 Alarm	-	-	-	-	-	-	-	-	-	-	-	Inactive	Active	None	None	
34	21P2 Alarm	-	-	-	-	-	-	-	-	-	-	-	Inactive	Active	None	None	
35	21P3 Alarm	-	-	-	-	-	-	-	-	-	-	-	Inactive	Active	None	None	
36	21P4 Alarm	-	-	-	-	-	-	-	-	-	-	-	Inactive	Active	None	None	
37	21N2 Alarm	-	-	-	-	-	-	-	-	-	-	-	Inactive	Active	None	None	
38	21N3 Alarm	-	-	-	-	-	-	-	-	-	-	-	Inactive	Active	None	None	
39	21N4 Alarm	-	-	-	-	-	-	-	-	-	-	-	Inactive	Active	None	None	
40	51 Alarm	-	-	-	-	-	-	-	-	-	-	-	Inactive	Active	None	None	
41	51N Alarm	-	-	-	-	-	-	-	-	-	-	-	Inactive	Active	None	None	
42	46-51 Alarm	-	-	-	-	-	-	-	-	-	-	-	Inactive	Active	None	None	
43	Self Check Fail	-	-	-	-	-	-	-	-	-	-	-	Inactive	Active	None	None	
44	68 OutBlinder Alarm	-	-	-	-	-	-	-	-	-	-	-	Inactive	Active	None	None	
45	68 InBlinder Alarm	-	-	-	-	-	-	-	-	-	-	-	Inactive	Active	None	None	
46	27 Main Trip	-	-	-	-	-	-	-	-	-	-	-	Inactive	Active	None	None	
47	27 Aux Trip	-	-	-	-	-	-	-	-	-	-	-	Inactive	Active	None	None	
48	59 Main Trip	-	-	-	-	-	-	-	-	-	-	-	Inactive	Active	None	None	
49	59 Aux Trip	-	-	-	-	-	-	-	-	-	-	-	Inactive	Active	None	None	
50	50LS Main	-	-	-	-	-	-	-	-	-	-	-	Inactive	Active	None	None	
51	25/27/59 Sync Check	-	-	-	-	-	-	-	-	-	-	-	Inactive	Active	None	None	
52	ProLogic 1	-	-	-	-	-	-	-	-	-	-	-	Inactive	Active	None	None	
53	ProLogic 2	-	-	-	-	-	-	-	-	-	-	-	Inactive	Active	None	None	
54	ProLogic 3	-	-	-	-	-	-	-	-	-	-	-	Inactive	Active	None	None	
55	ProLogic 4	-	-	-	-	-	-	-	-	-	-	-	Inactive	Active	None	None	
56	ProLogic 5	-	-	-	-	-	-	-	-	-	-	-	Inactive	Active	None	None	
57	ProLogic 6	-	-	-	-	-	-	-	-	-	-	-	Inactive	Active	None	None	
58	ProLogic 7	-	-	-	-	-	-	-	-	-	-	-	Inactive	Active	None	None	
59	ProLogic 8	-	-	-	-	-	-	-	-	-	-	-	Inactive	Active	None	None	
60	ProLogic 9	-	-	-	-	-	-	-	-	-	-	-	Inactive	Active	None	None	
61	ProLogic 10	-	-	-	-	-	-	-	-	-	-	-	Inactive	Active	None	None	

Point Index	Name	Supported Control Operations											Name for State when value is 0	Name for State when value is 1	Default Class Assigned to Events (1, 2, 3 or none)		Description	
		Select/Operate	Direct Operate	Direct Operate - No Ack	Pulse On / NUL	Pulse Off	Latch On / NUL	Latch Off / NUL	Trip	Close	Count > 1	Cancel Currently Running Operation			Change	Command		
62	50LS Aux	-	-	-	-	-	-	-	-	-	-	-	-	Inactive	Active	None	None	
63	Group Logic 1	-	-	-	-	-	-	-	-	-	-	-	-	Inactive	Active	None	None	
64	Group Logic 2	-	-	-	-	-	-	-	-	-	-	-	-	Inactive	Active	None	None	
65	Group Logic 3	-	-	-	-	-	-	-	-	-	-	-	-	Inactive	Active	None	None	
66	Group Logic 4	-	-	-	-	-	-	-	-	-	-	-	-	Inactive	Active	None	None	
67	Group Logic 5	-	-	-	-	-	-	-	-	-	-	-	-	Inactive	Active	None	None	
68	Group Logic 6	-	-	-	-	-	-	-	-	-	-	-	-	Inactive	Active	None	None	
69	Group Logic 7	-	-	-	-	-	-	-	-	-	-	-	-	Inactive	Active	None	None	
70	Group Logic 8	-	-	-	-	-	-	-	-	-	-	-	-	Inactive	Active	None	None	
71	Group Logic 9	-	-	-	-	-	-	-	-	-	-	-	-	Inactive	Active	None	None	
72	Group Logic 10	-	-	-	-	-	-	-	-	-	-	-	-	Inactive	Active	None	None	
73	Group Logic 11	-	-	-	-	-	-	-	-	-	-	-	-	Inactive	Active	None	None	
74	Group Logic 12	-	-	-	-	-	-	-	-	-	-	-	-	Inactive	Active	None	None	
75	Group Logic 13	-	-	-	-	-	-	-	-	-	-	-	-	Inactive	Active	None	None	
76	Group Logic 14	-	-	-	-	-	-	-	-	-	-	-	-	Inactive	Active	None	None	
77	Group Logic 15	-	-	-	-	-	-	-	-	-	-	-	-	Inactive	Active	None	None	
78	Group Logic 16	-	-	-	-	-	-	-	-	-	-	-	-	Inactive	Active	None	None	
79	79 Initiated	-	-	-	-	-	-	-	-	-	-	-	-	Inactive	Active	None	None	
80	79 Blocked	-	-	-	-	-	-	-	-	-	-	-	-	Inactive	Active	None	None	
81	50BF-1 Main	-	-	-	-	-	-	-	-	-	-	-	-	Inactive	Active	None	None	
82	50BF-2 Main	-	-	-	-	-	-	-	-	-	-	-	-	Inactive	Active	None	None	
83	50BF-1 Aux	-	-	-	-	-	-	-	-	-	-	-	-	Inactive	Active	None	None	
84	50BF-2 Aux	-	-	-	-	-	-	-	-	-	-	-	-	Inactive	Active	None	None	
85	79 Main Reclose	-	-	-	-	-	-	-	-	-	-	-	-	Inactive	Active	None	None	
86	79 Aux Reclose	-	-	-	-	-	-	-	-	-	-	-	-	Inactive	Active	None	None	
87	79 Lead Lockout	-	-	-	-	-	-	-	-	-	-	-	-	Inactive	Active	None	None	
88	79 Follow Lockout	-	-	-	-	-	-	-	-	-	-	-	-	Inactive	Active	None	None	
89	81-1 Trip	-	-	-	-	-	-	-	-	-	-	-	-	Inactive	Active	None	None	
90	81-2 Trip	-	-	-	-	-	-	-	-	-	-	-	-	Inactive	Active	None	None	
91	81-3 Trip	-	-	-	-	-	-	-	-	-	-	-	-	Inactive	Active	None	None	
92	81-4 Trip	-	-	-	-	-	-	-	-	-	-	-	-	Inactive	Active	None	None	
93	50BF Initiate	-	-	-	-	-	-	-	-	-	-	-	-	Inactive	Active	None	None	
94	Virtual Input 1	Y	Y	Y	Y	-	Y	Y	-	-	-	-	-	Inactive	Active	None	None	Pulse duration fixed at 1 s
95	Virtual Input 2	Y	Y	Y	Y	-	Y	Y	-	-	-	-	-	Inactive	Active	None	None	Pulse duration fixed at 1 s
96	Virtual Input 3	Y	Y	Y	Y	-	Y	Y	-	-	-	-	-	Inactive	Active	None	None	Pulse duration fixed at 1 s
97	Virtual Input 4	Y	Y	Y	Y	-	Y	Y	-	-	-	-	-	Inactive	Active	None	None	Pulse duration fixed at 1 s
98	Virtual Input 5	Y	Y	Y	Y	-	Y	Y	-	-	-	-	-	Inactive	Active	None	None	Pulse duration fixed at 1 s
99	Virtual Input 6	Y	Y	Y	Y	-	Y	Y	-	-	-	-	-	Inactive	Active	None	None	Pulse duration fixed at 1 s

Appendix F DNP3 Device Profile

Point Index	Name	Supported Control Operations											Name for State when value is 0	Name for State when value is 1	Default Class Assigned to Events (1, 2, 3 or none)		Description
		Select/Operate	Direct Operate	Direct Operate - No Ack	Pulse On / NUL	Pulse Off	Latch On / NUL	Latch Off / NUL	Trip	Close	Count > 1	Cancel Currently Running Operation			Change	Command	
100	Virtual Input 7	Y	Y	Y	Y	-	Y	Y	-	-	-	-	Inactive	Active	None	None	Pulse duration fixed at 1 s
101	Virtual Input 8	Y	Y	Y	Y	-	Y	Y	-	-	-	-	Inactive	Active	None	None	Pulse duration fixed at 1 s
102	Virtual Input 9	Y	Y	Y	Y	-	Y	Y	-	-	-	-	Inactive	Active	None	None	Pulse duration fixed at 1 s
103	Virtual Input 10	Y	Y	Y	Y	-	Y	Y	-	-	-	-	Inactive	Active	None	None	Pulse duration fixed at 1 s
104	Virtual Input 11	Y	Y	Y	Y	-	Y	Y	-	-	-	-	Inactive	Active	None	None	Pulse duration fixed at 1 s
105	Virtual Input 12	Y	Y	Y	Y	-	Y	Y	-	-	-	-	Inactive	Active	None	None	Pulse duration fixed at 1 s
106	Virtual Input 13	Y	Y	Y	Y	-	Y	Y	-	-	-	-	Inactive	Active	None	None	Pulse duration fixed at 1 s
107	Virtual Input 14	Y	Y	Y	Y	-	Y	Y	-	-	-	-	Inactive	Active	None	None	Pulse duration fixed at 1 s
108	Virtual Input 15	Y	Y	Y	Y	-	Y	Y	-	-	-	-	Inactive	Active	None	None	Pulse duration fixed at 1 s
109	Virtual Input 16	Y	Y	Y	Y	-	Y	Y	-	-	-	-	Inactive	Active	None	None	Pulse duration fixed at 1 s
110	Virtual Input 17	Y	Y	Y	Y	-	Y	Y	-	-	-	-	Inactive	Active	None	None	Pulse duration fixed at 1 s
111	Virtual Input 18	Y	Y	Y	Y	-	Y	Y	-	-	-	-	Inactive	Active	None	None	Pulse duration fixed at 1 s
112	Virtual Input 19	Y	Y	Y	Y	-	Y	Y	-	-	-	-	Inactive	Active	None	None	Pulse duration fixed at 1 s
113	Virtual Input 20	Y	Y	Y	Y	-	Y	Y	-	-	-	-	Inactive	Active	None	None	Pulse duration fixed at 1 s
114	Virtual Input 21	Y	Y	Y	Y	-	Y	Y	-	-	-	-	Inactive	Active	None	None	Pulse duration fixed at 1 s
115	Virtual Input 22	Y	Y	Y	Y	-	Y	Y	-	-	-	-	Inactive	Active	None	None	Pulse duration fixed at 1 s
116	Virtual Input 23	Y	Y	Y	Y	-	Y	Y	-	-	-	-	Inactive	Active	None	None	Pulse duration fixed at 1 s
117	Virtual Input 24	Y	Y	Y	Y	-	Y	Y	-	-	-	-	Inactive	Active	None	None	Pulse duration fixed at 1 s
118	Virtual Input 25	Y	Y	Y	Y	-	Y	Y	-	-	-	-	Inactive	Active	None	None	Pulse duration fixed at 1 s
119	Virtual Input 26	Y	Y	Y	Y	-	Y	Y	-	-	-	-	Inactive	Active	None	None	Pulse duration fixed at 1 s
120	Virtual Input 27	Y	Y	Y	Y	-	Y	Y	-	-	-	-	Inactive	Active	None	None	Pulse duration fixed at 1 s
121	Virtual Input 28	Y	Y	Y	Y	-	Y	Y	-	-	-	-	Inactive	Active	None	None	Pulse duration fixed at 1 s
122	Virtual Input 29	Y	Y	Y	Y	-	Y	Y	-	-	-	-	Inactive	Active	None	None	Pulse duration fixed at 1 s
123	Virtual Input 30	Y	Y	Y	Y	-	Y	Y	-	-	-	-	Inactive	Active	None	None	Pulse duration fixed at 1 s
124	Get Next Fault Event	Y	Y	Y	Y	-	Y	Y	-	-	-	-	Inactive	Active	None	None	Pulse duration fixed at 1 s
125	Output Contact 15	-	-	-	-	-	-	-	-	-	-	-	Open	Closed	None	None	
126	Output Contact 16	-	-	-	-	-	-	-	-	-	-	-	Open	Closed	None	None	



Point Index	Name	Supported Control Operations											Name for State when value is 0	Name for State when value is 1	Default Class Assigned to Events (1, 2, 3 or none)		Description	
		Select/Operate	Direct Operate	Direct Operate - No Ack	Pulse On / NUL	Pulse Off	Latch On / NUL	Latch Off / NUL	Trip	Close	Count > 1	Cancel Currently Running Operation			Change	Command		
127	Output Contact 17	-	-	-	-	-	-	-	-	-	-	-	-	Open	Closed	None	None	
128	Output Contact 18	-	-	-	-	-	-	-	-	-	-	-	-	Open	Closed	None	None	
129	Output Contact 19	-	-	-	-	-	-	-	-	-	-	-	-	Open	Closed	None	None	
130	Output Contact 20	-	-	-	-	-	-	-	-	-	-	-	-	Open	Closed	None	None	
131	Output Contact 21	-	-	-	-	-	-	-	-	-	-	-	-	Open	Closed	None	None	
132	ProLogic 11	-	-	-	-	-	-	-	-	-	-	-	-	Inactive	Active	None	None	
133	ProLogic 12	-	-	-	-	-	-	-	-	-	-	-	-	Inactive	Active	None	None	

<b>2.3 Analog Input Points</b> Static (Steady-State) Group Number: 30 Event Group Number: 32	<b>Capabilities</b>	<b>Current Value</b>	<b>If configurable, list methods</b>
2.3.1 Static Variation reported when variation 0 requested:	<input type="checkbox"/> Variation 1 - 32-bit with flag <input type="checkbox"/> Variation 2 - 16-bit with flag <input type="checkbox"/> Variation 3 - 32-bit without flag <input checked="" type="checkbox"/> Variation 4 - 16-bit without flag <input type="checkbox"/> Variation 5 - single-precision floating point with flag <input type="checkbox"/> Variation 6 - double-precision floating point with flag <input type="checkbox"/> Based on point Index (add column to table below)		
2.3.2 Event Variation reported when variation 0 requested:	<input type="checkbox"/> Variation 1 - 32-bit without time <input checked="" type="checkbox"/> Variation 2 - 16-bit without time <input type="checkbox"/> Variation 3 - 32-bit with time <input type="checkbox"/> Variation 4 - 16-bit with time <input type="checkbox"/> Variation 5 - single-precision floating point w/o time <input type="checkbox"/> Variation 6 - double-precision floating point w/o time <input type="checkbox"/> Variation 7 - single-precision floating point with time <input type="checkbox"/> Variation 8 - double-precision floating point with time <input type="checkbox"/> Based on point Index (add column to table below)		
2.3.3 Event reporting mode:	<input type="checkbox"/> Only most recent <input checked="" type="checkbox"/> All events		
2.3.4 Analog Inputs Included in Class 0 response:	<input checked="" type="checkbox"/> Always <input type="checkbox"/> Never <input type="checkbox"/> Only if point is assigned to Class 1, 2, or 3 <input type="checkbox"/> Based on point Index (add column to table below)		
2.3.5 How Deadbands are set:	<input type="checkbox"/> A. Global Fixed <input type="checkbox"/> B. Configurable through DNP <input checked="" type="checkbox"/> C. Configurable via other means <input type="checkbox"/> D. Other, explain _____ <input type="checkbox"/> Based on point Index - column specifies which of the options applies, B, C, or D		L-PRO Offliner
2.3.6 Analog Deadband Algorithm: simple - just compares the difference from the previous reported value	<input checked="" type="checkbox"/> Simple <input type="checkbox"/> Integrating <input type="checkbox"/> Other, explain _____		
2.3.7 Definition of Analog Input Point List:	<input type="checkbox"/> Fixed, list shown in table below <input checked="" type="checkbox"/> Configurable <input type="checkbox"/> Other, explain _____	Default list is shown in table below	L-PRO Offliner

**NOTES**

1. Analog Inputs are scanned with 500 ms resolution.
2. Nominal values in calculations for the following table are based on 69V secondary voltage \* PT ratio for voltage channels, and either 1 A or 5A secondary current \* CT ratio for current channels dependent upon the format of CT installed in the L-PRO.
3. Analog Input data points are user selectable; the data points available in the device for any given Analog Input point selection can be obtained through the L-PRO Offliner software (see SCADA Setting Summary).

Point Index	Name	Default Class Assigned to Events (1, 2, 3 or none)	Transmitted Value <sup>a</sup>		Scaling <sup>b</sup>		Units	Resolution <sup>d</sup> (default/ maximal)	Description
			Minimum	Maximum <sup>c</sup>	Multiplier (default/ (range))	Offset			
0	Line Va Magnitude	2	0	Configurable	0.1 / (0.00001- 1.0)	0.0	KV	0.1 / 0.00001	
1	Line Va Angle	2	-18,000	18,000	0.1 / (0.01 - 1.0)	0.0	degrees	0.1 / 0.01	
2	Line Vb Magnitude	2	0	Configurable	0.1 / (0.00001- 1.0)	0.0	KV	0.1 / 0.00001	
3	Line Vb Angle	2	-18,000	18,000	0.1 / (0.01 - 1.0)	0.0	degrees	0.1 / 0.01	
4	Line Vc Magnitude	2	0	Configurable	0.1 / (0.00001- 1.0)	0.0	KV	0.1 / 0.00001	
5	Line Vc Angle	2	-18,000	18,000	0.1 / (0.01 - 1.0)	0.0	degrees	0.1 / 0.01	
6	Line Ia Magnitude	2	0	Configurable	1.0 / (0.01 - 1000)	0.0	A	1.0 / 0.01	
7	Line Ia Angle	2	-18,000	18,000	0.1 / (0.01 - 1.0)	0.0	degrees	0.1 / 0.01	
8	Line Ib Magnitude	2	0	Configurable	1.0 / (0.01 - 1000)	0.0	A	1.0 / 0.01	
9	Line Ib Angle	2	-18,000	18,000	0.1 / (0.01 - 1.0)	0.0	degrees	0.1 / 0.01	
10	Line Ic Magnitude	2	0	Configurable	1.0 / (0.01 - 1000)	0.0	A	1.0 / 0.01	
11	Line Ic Angle	2	-18,000	18,000	0.1 / (0.01 - 1.0)	0.0	degrees	0.1 / 0.01	
12	I2a Magnitude	2	0	Configurable	1.0 / (0.01 - 1000)	0.0	A	1.0 / 0.01	
13	I2a Angle	2	-18,000	18,000	0.1 / (0.01 - 1.0)	0.0	degrees	0.1 / 0.01	
14	I2b Magnitude	2	0	Configurable	1.0 / (0.01 - 1000)	0.0	A	1.0 / 0.01	
15	I2b Angle	2	-18,000	18,000	0.1 / (0.01 - 1.0)	0.0	degrees	0.1 / 0.01	
16	I2c Magnitude	2	0	Configurable	1.0 / (0.01 - 1000)	0.0	A	1.0 / 0.01	
17	I2c Angle	2	-18,000	18,000	0.1 / (0.01 - 1.0)	0.0	degrees	0.1 / 0.01	
18	I3a Magnitude	2	0	Configurable	1.0 / (0.01 - 1000)	0.0	A	1.0 / 0.01	
19	I3a Angle	2	-18,000	18,000	0.1 / (0.01 - 1.0)	0.0	degrees	0.1 / 0.01	
20	I3b Magnitude	2	0	Configurable	1.0 / (0.01 - 1000)	0.0	A	1.0 / 0.01	
21	I3b Angle	2	-18,000	18,000	0.1 / (0.01 - 1.0)	0.0	degrees	0.1 / 0.01	
22	I3c Magnitude	2	0	Configurable	1.0 / (0.01 - 1000)	0.0	A	1.0 / 0.01	
23	I3c Angle	2	-18,000	18,000	0.1 / (0.01 - 1.0)	0.0	degrees	0.1 / 0.01	
24	I4a Magnitude	2	0	Configurable	1.0 / (0.01 - 1000)	0.0	A	1.0 / 0.01	
25	I4a Angle	2	-18,000	18,000	0.1 / (0.01 - 1.0)	0.0	degrees	0.1 / 0.01	
26	I4b Magnitude	2	0	Configurable	1.0 / (0.01 - 1000)	0.0	A	1.0 / 0.01	
27	I4b Angle	2	-18,000	18,000	0.1 / (0.01 - 1.0)	0.0	degrees	0.1 / 0.01	
28	I4c Magnitude	2	0	Configurable	1.0 / (0.01 - 1000)	0.0	A	1.0 / 0.01	
29	I4c Angle	2	-18,000	18,000	0.1 / (0.01 - 1.0)	0.0	degrees	0.1 / 0.01	
30	Bus Va Magnitude	2	0	Configurable	0.1 / (0.00001- 1.0)	0.0	KV	0.1 / 0.00001	
31	Bus Va Angle	2	-18,000	18,000	0.1 / (0.01 - 1.0)	0.0	degrees	0.1 / 0.01	
32	Bus Vb Magnitude	2	0	Configurable	0.1 / (0.00001- 1.0)	0.0	KV	0.1 / 0.00001	

Point Index	Name	Default Class Assigned to Events (1, 2, 3 or none)	Transmitted Value <sup>a</sup>		Scaling <sup>b</sup>		Units	Resolution <sup>d</sup> (default/ maximal)	Description
			Minimum	Maximum <sup>c</sup>	Multiplier (default/ (range))	Offset			
33	Bus Vb Angle	2	-18,000	18,000	0.1 / (0.01 - 1.0)	0.0	degrees	0.1 / 0.01	
34	Bus Vc Magnitude	2	0	Configurable	0.1 / (0.00001- 1.0)	0.0	KV	0.1 / 0.00001	
35	Bus Vc Angle	2	-18,000	18,000	0.1 / (0.01 - 1.0)	0.0	degrees	0.1 / 0.01	
36	Pos Seq Frequency	2	0	Configurable	0.01 / (0.001 - 1.0)	0.0	Hz	0.01 / 0.001	
37	P	2	0	Configurable	0.1 / (0.00001- 1.0)	0.0	MW	0.1 / 0.00001	
38	Q	2	0	Configurable	0.1 / (0.00001- 1.0)	0.0	Mvar	0.1 / 0.00001	
39	Pos Seq Voltage	2	0	Configurable	0.1 / (0.00001- 1.0)	0.0	KV	0.1 / 0.00001	
40	Pos Seq Current	2	0	Configurable	1.0 / (0.01 - 1000)	0.0	A	1.0 / 0.01	
41	Not used	2	0	0	1.0	0.0	NA	NA	Retained for legacy applications
42	Not used	2	0	0	1.0	0.0	NA	NA	Retained for legacy applications
43	Not used	2	0	0	1.0	0.0	NA	NA	Retained for legacy applications
44	Not used	2	0	0	1.0	0.0	NA	NA	Retained for legacy applications
45	Not used	2	0	0	1.0	0.0	NA	NA	Retained for legacy applications
46	Not used	2	0	0	1.0	0.0	NA	NA	Retained for legacy applications
47	Not used	2	0	0	1.0	0.0	NA	NA	Retained for legacy applications
48	Not used	2	0	0	1.0	0.0	NA	NA	Retained for legacy applications
49	Not used	2	0	0	1.0	0.0	NA	NA	Retained for legacy applications
50	Not used	2	0	0	1.0	0.0	NA	NA	Retained for legacy applications
51	Not used	2	0	0	1.0	0.0	NA	NA	Retained for legacy applications
52	Not used	2	0	0	1.0	0.0	NA	NA	Retained for legacy applications
53	Active Setting Group Number	2	1	8	1.0	0.0	NA	1.0	
54	Fault Information - DNP Time (High 16 bits)	2	0	65,535	1.0	0.0	NA	1.0	See description below on how to access Fault Information.
55	Fault Information - DNP Time (Middle 16 bits)	2	0	65,535	1.0	0.0	NA	1.0	
56	Fault Information - DNP Time (Low 16 bits)	2	0	65,535	1.0	0.0	NA	1.0	
57	Fault Information - Fault Distance	2	0	Configurable	0.1	0.0	Configurable	0.1	
58	Fault Information - Type	2	0	15	1.0	0.0	NA	1.0	
59	Ia Summated Magnitude	2	0	Configurable	1.0 / (0.01 - 1000)	0.0	A	1.0 / 0.01	
60	Ia Summated Angle	2	-18,000	18,000	0.1 / (0.01 - 1.0)	0.0	degrees	0.1 / 0.01	
61	Ib Summated Magnitude	2	0	Configurable	1.0 / (0.01 - 1000)	0.0	A	1.0 / 0.01	
62	Ib Summated Angle	2	-18,000	18,000	0.1 / (0.01 - 1.0)	0.0	degrees	0.1 / 0.01	
63	Ic Summated Magnitude	2	0	Configurable	1.0 / (0.01 - 1000)	0.0	A	1.0 / 0.01	
64	Ic Summated Angle	2	-18,000	18,000	0.1 / (0.01 - 1.0)	0.0	degrees	0.1 / 0.01	

Point Index	Name	Default Class Assigned to Events (1, 2, 3 or none)	Transmitted Value <sup>a</sup>		Scaling <sup>b</sup>		Units	Resolution <sup>d</sup> (default/ maximal)	Description
			Minimum	Maximum <sup>c</sup>	Multiplier (default/ (range))	Offset			
65	Self check Fail	2	0	65,535	1.0	0.0	NA	1.0	

- The minimum and maximum transmitted values are the lowest and highest values that the outstation will report in DNP analog input objects. These values are integers if the outstation transmits only integers. If the outstation is capable of transmitting both integers and floating-point, then integer and floating-point values are required for the minimums and maximums. For example, a pressure sensor is able to measure 0 to 500 kPa. The outstation provides a linear conversion of the sensor's output signal to integers in the range of 0 to 25000 or floating-point values of 0 to 500.000. The sensor and outstation are used in an application where the maximum possible pressure is 380 kPa. For this input, the minimum transmitted value would be stated as 0 / 0.0 and the maximum transmitted value would be stated as 19000 / 380.000.
- The scaling information for each point specifies how data transmitted in integer variations (16 bit and 32 bit) is converted to engineering units when received by the Master (i.e. scaled according to the equation: scaled value = multiplier \* raw + offset). Scaling is not applied to Floating point variations since they are already transmitted in engineering units.
- Resolution is the smallest change that may be detected in the value due to quantization errors and is given in the units shown in the previous column. This parameter does not represent the accuracy of the measurement.
- Maximal values are calculated as (2 \* Configured Nominal / Multiplier) for voltage channels and as (20 \* Configured Nominal / Multiplier) for current channels (see Note 2 above for the nominal definitions).

When a fault location event is available, Binary Input "Fault Information Available" (default point index 39) is asserted while there are still fault location events in the buffer (size 100). When a Pulse or Latch is received for the Binary Output "Get Next Fault Event" (default point index 124, previous state is not important), fault event information is put into the Analog Inputs. If there is no fault location event available when the Binary Output is pulsed, the fault type is set to zero.

Not all fault location events are reported through DNP. In a burst of fault locations from a fault, only the first processed event is available through DNP, all other events within the following 100 ms interval are ignored. Outside 100 ms from the processed fault location event, the system accepts another fault location event and performs the same filtering. In addition, only fault location events generated by trip elements are available.

2.4 Octet String Points Static (Steady-State) Group Number: 110 Event Group Number: 111		Capabilities	Current Value	If configurable, list methods
2.4.1	Event reporting mode *:	<input type="checkbox"/> Only most recent <input checked="" type="checkbox"/> All events		
2.4.2	Octet Strings Included in Class 0 response:	<input type="checkbox"/> Always <input checked="" type="checkbox"/> Never <input type="checkbox"/> Only if point is assigned to Class 1, 2, or 3 <input type="checkbox"/> Based on point Index (add column to table below)		
2.4.3	Definition of Octet String Point List:	<input type="checkbox"/> Fixed, list shown in table below <input type="checkbox"/> Configurable (current list may be shown in table below) <input checked="" type="checkbox"/> Other, explain <u>Used for Event Log access as described below</u>		

\* Object 110 and 111 are Octet String Object used to provide access to the Event Log text of the relay. Object 110 always contains the most recent event in the relay. Object 111 is the corresponding change event object.

As stated in the DNP specifications, the variation of the response object represents the length of the string. The string represents the ASCII values of the event text. The first two characters in the string can be used to quickly identify fault location events. Fault locator events begin with the characters "FL" (0x46, 0x4C hex). The following example shows a fault distance event returned through either of the octet string objects:

Event Message:

FL2000Sep21 20:16:16.966: 21P1 AB 1.0km: Trip

DNP Octet string object components:					
0x46	0x4C	0x32	0x30	0x30	030x
0x53	0x65	0x70	0x32	0x31	0x20
0x32	0x30	0x3A	0x31	0x36	0x3A
0x31	0x36	0x2E	0x39	0x36	0x36
0x20	0x32	0x31	0x50	0x31	0x20
0x41	0x42	0x20	0x31	0x2E	0x30
0x6B	0x6D	0x3A	0x20	0x54	0x72
0x69	0x70				

## Implementation Table

The following implementation table identifies which object groups and variations, function codes and qualifiers the device supports in both requests and responses. The Request columns identify all requests that may be sent by a Master, or all requests that must be parsed by an Outstation. The Response columns identify all responses that must be parsed by a Master, or all responses that may be sent by an Outstation.

### NOTES

The implementation table must list all functionality required by the device whether Master or Outstation as defined within the DNP3 IED Conformance Test Procedures. Any functionality beyond the highest subset level supported is indicated by highlighted rows. Any Object Groups not provided by an outstation or not processed by a Master are indicated by strikethrough (note these Object Groups will still be parsed).

DNP Object Group & Variation			Request Outstation parses		Response Outstation can issue	
Group Num	Var Num	Description	Function Codes (dec)	Qualifier Codes (hex)	Function Codes (dec)	Qualifier Codes (hex)
1	0	Binary Input - Any Variation	1 (read)	06 (no range, or all) 00, 01 (start-stop) 07, 08 (limited qty) 17, 28 (index)	129 (response)	00, 01 (start-stop)
1	1	Binary Input - Packed format	1 (read)	06 (no range, or all) 00, 01 (start-stop) 07, 08 (limited qty) 17, 28 (index)	129 (response)	00, 01 (start-stop)
1	2	Binary Input - With flags	1 (read)	06 (no range, or all) 00, 01 (start-stop) 07, 08 (limited qty) 17, 28 (index)	129 (response)	00, 01 (start-stop)
2	0	Binary Input Event - Any Variation	1 (read)	06 (no range, or all) 07, 08 (limited qty)	129 (response)	17, 28 (index)
2	1	Binary Input Event - Without time	1 (read)	06 (no range, or all) 07, 08 (limited qty)	129 (response) <del>430 (unsol-reep)</del>	17, 28 (index)
2	2	Binary Input Event - With absolute time	1 (read)	06 (no range, or all) 07, 08 (limited qty)	129 (response) <del>430 (unsol-reep)</del>	17, 28 (index)
2	3	Binary Input Event - With relative time	1 (read)	06 (no range, or all) 07, 08 (limited qty)	129 (response) <del>430 (unsol-reep)</del>	17, 28 (index)
10	0	Binary Output - Any Variation	1 (read)	06 (no range, or all) 00, 01 (start-stop) 07, 08 (limited qty) 17, 28 (index)	129 (response)	00, 01 (start-stop)
10	2	Binary Output - Output Status with flag	1 (read)	06 (no range, or all) 00, 01 (start-stop) 07, 08 (limited qty) 17, 28 (index)	129 (response)	00, 01 (start-stop)
12	1	Binary Command - Control relay output block (CROB)	3 (select) 4 (operate) 5 (direct op) 6 (dir. op, no ack)	17, 28 (index)	129 (response)	Echo of request

Appendix F DNP3 Device Profile

DNP Object Group & Variation			Request Outstation parses		Response Outstation can issue	
Group Num	Var Num	Description	Function Codes (dec)	Qualifier Codes (hex)	Function Codes (dec)	Qualifier Codes (hex)
20	0	Counter - Any Variation	1 (read) 7 (freeze) 8 (freeze noack) 9 (freeze clear) 10 (frz. cl. noack)	06 (no range, or all)	129 (response)	
20	1	Counter - 32-bit with flag			129 (response)	00, 01 (start-stop)
20	2	Counter - 16-bit with flag			129 (response)	00, 01 (start-stop)
20	5	Counter - 32-bit without flag			129 (response)	00, 01 (start-stop)
20	6	Counter - 16-bit without flag			129 (response)	00, 01 (start-stop)
21	0	Frozen Counter - Any Variation	1 (read)	06 (no range, or all)		
21	1	Frozen Counter - 32-bit with flag			129 (response)	00, 01 (start-stop)
21	2	Frozen Counter - 16-bit with flag			129 (response)	00, 01 (start-stop)
21	9	Frozen Counter - 32-bit without flag			129 (response)	00, 01 (start-stop)
21	10	Frozen Counter - 16-bit without flag			129 (response)	00, 01 (start-stop)
22	0	Counter Event - Any Variation	1 (read)	06 (no range, or all) 07, 08 (limited qty)		
22	1	Counter Event - 32-bit with flag			129 (response) 430 (unsol-resp)	17, 28 (index)
22	2	Counter Event - 16-bit with flag			129 (response) 430 (unsol-resp)	17, 28 (index)
30	0	Analog Input - Any Variation	1 (read)	06 (no range, or all) 00, 01 (start-stop) 07, 08 (limited qty) 17, 28 (index)	129 (response)	00, 01 (start-stop)
30	1	Analog Input - 32-bit with flag	1 (read)	06 (no range, or all) 00, 01 (start-stop) 07, 08 (limited qty) 17, 28 (index)	129 (response)	00, 01 (start-stop)
30	2	Analog Input - 16-bit with flag	1 (read)	06 (no range, or all) 00, 01 (start-stop) 07, 08 (limited qty) 17, 28 (index)	129 (response)	00, 01 (start-stop)
30	3	Analog Input - 32-bit without flag	1 (read)	06 (no range, or all) 00, 01 (start-stop) 07, 08 (limited qty) 17, 28 (index)	129 (response)	00, 01 (start-stop)
30	4	Analog Input - 16-bit without flag	1 (read)	06 (no range, or all) 00, 01 (start-stop) 07, 08 (limited qty) 17, 28 (index)	129 (response)	
32	0	Analog Input Event - Any Variation	1 (read)	06 (no range, or all) 07, 08 (limited qty)	129 (response)	17, 28 (index)
32	1	Analog Input Event - 32-bit without time	1 (read)	06 (no range, or all) 07, 08 (limited qty)	129 (response) 430 (unsol-resp)	17, 28 (index)
32	2	Analog Input Event - 16-bit without time	1 (read)	06 (no range, or all) 07, 08 (limited qty)	129 (response) 430 (unsol-resp)	17, 28 (index)
32	3	Analog Input Event - 32-bit with time	1 (read)	06 (no range, or all) 07, 08 (limited qty)	129 (response)	17, 28 (index)
32	4	Analog Input Event - 16-bit with time	1 (read)	06 (no range, or all) 07, 08 (limited qty)	129 (response)	17, 28 (index)
40	0	Analog Output Status - Any Variation	1 (read)	06 (no range, or all)	129 (response)	



DNP Object Group & Variation			Request Outstation parses		Response Outstation can issue	
Group Num	Var Num	Description	Function Codes (dec)	Qualifier Codes (hex)	Function Codes (dec)	Qualifier Codes (hex)
40	2	<del>Analog Output Status - 16 bit with flag</del>			129 (response)	<del>00, 01 (start-stop)</del>
41	2	<del>Analog Output - 16 bit</del>	3 (select) 4 (operate) 5 (direct op) 6 (dir. op, no ack)	17, 28 (index)	129 (response)	<del>Echo of request</del>
50	1	<del>Time and Date - Absolute time</del>	2 (write)	07 (limited qty = 1)	129 (response)	
51	1	<del>Time and Date CTO - Absolute time, synchronized</del>			<del>129 (response) 130 (unsol. resp)</del>	<del>07 (limited qty) (qty = 1)</del>
51	2	Time and Date CTO - Absolute time, unsynchronized			129 (response) 130 (unsol. resp)	07 (limited qty) (qty = 1)
52	1	Time Delay - Coarse			129 (response)	07 (limited qty) (qty = 1)
52	2	<del>Time delay - Fine</del>			<del>129 (response)</del>	<del>07 (limited qty) (qty = 1)</del>
60	1	Class Objects - Class 0 data	1 (read)	06 (no range, or all)	129 (response)	00, 01 (start-stop)
60	2	Class Objects - Class 1 data	1 (read)	06 (no range, or all)	129 (response)	17, 28 (index)
60	3	Class Objects - Class 2 data	1 (read)	06 (no range, or all)	129 (response)	17, 28 (index)
60	4	Class Objects - Class 3 data	1 (read)	06 (no range, or all)	129 (response)	17, 28 (index)
80	1	Internal Indications - Packet format	2 (write)	00 (start-stop) (index = 7)	129 (response)	
110	0	Octet string	1 (read)	06 (no range, or all)	129 (response)	07 (limited qty)
111	0	Octet string event	1 (read)	06 (no range, or all)	129 (response)	07 (limited qty)
No Object (function code only)			13 (cold restart)		129 (response)	
No Object (function code only)			14 (warm restart)		129 (response)	
No Object (function code only)			23 (delay meas.)		129 (response)	



# Appendix G Mechanical Drawings

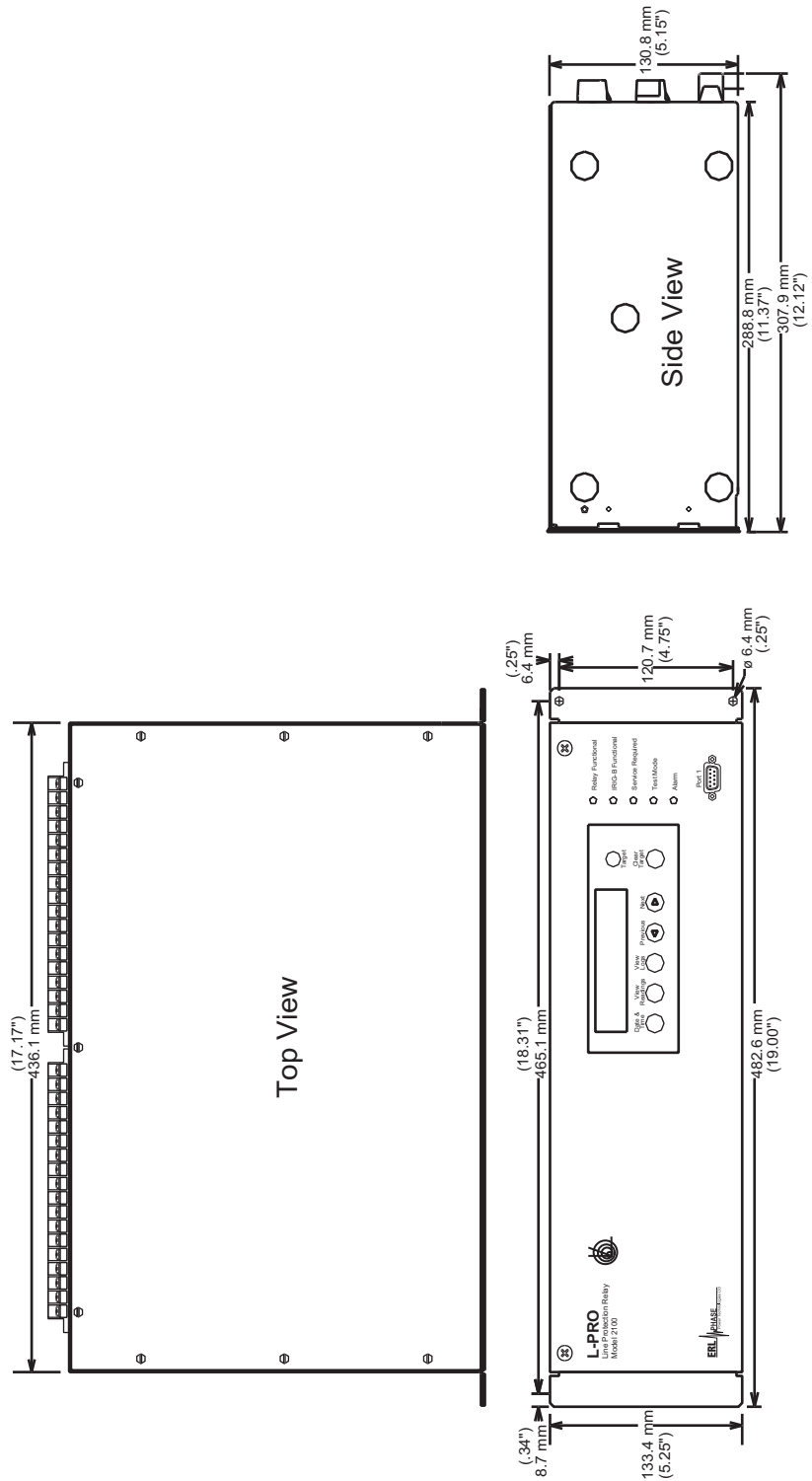

Figure G.1: Mechanical Drawing – 3U Chassis

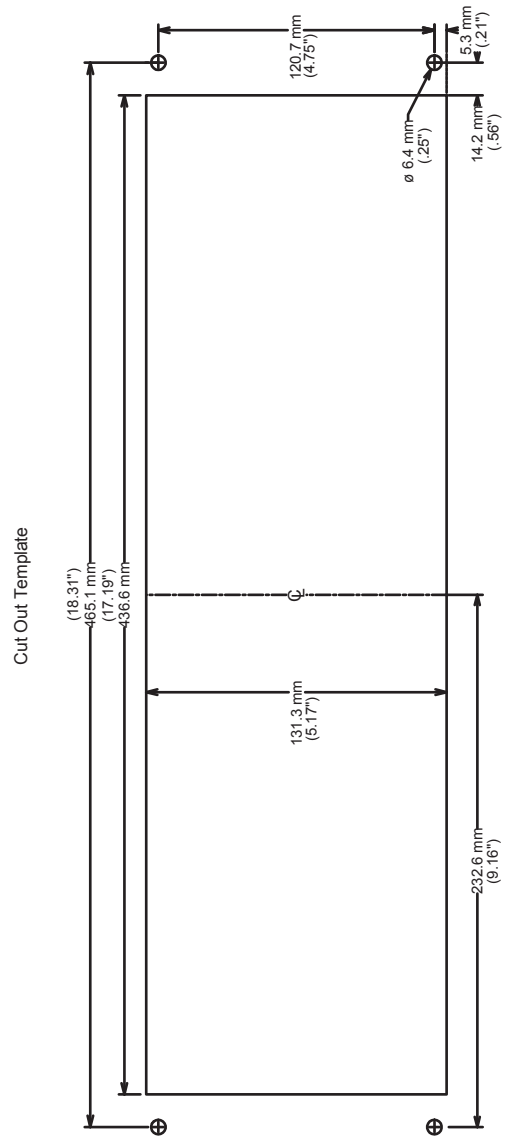

Figure G.2: Cut-out Template – 3U Chassis

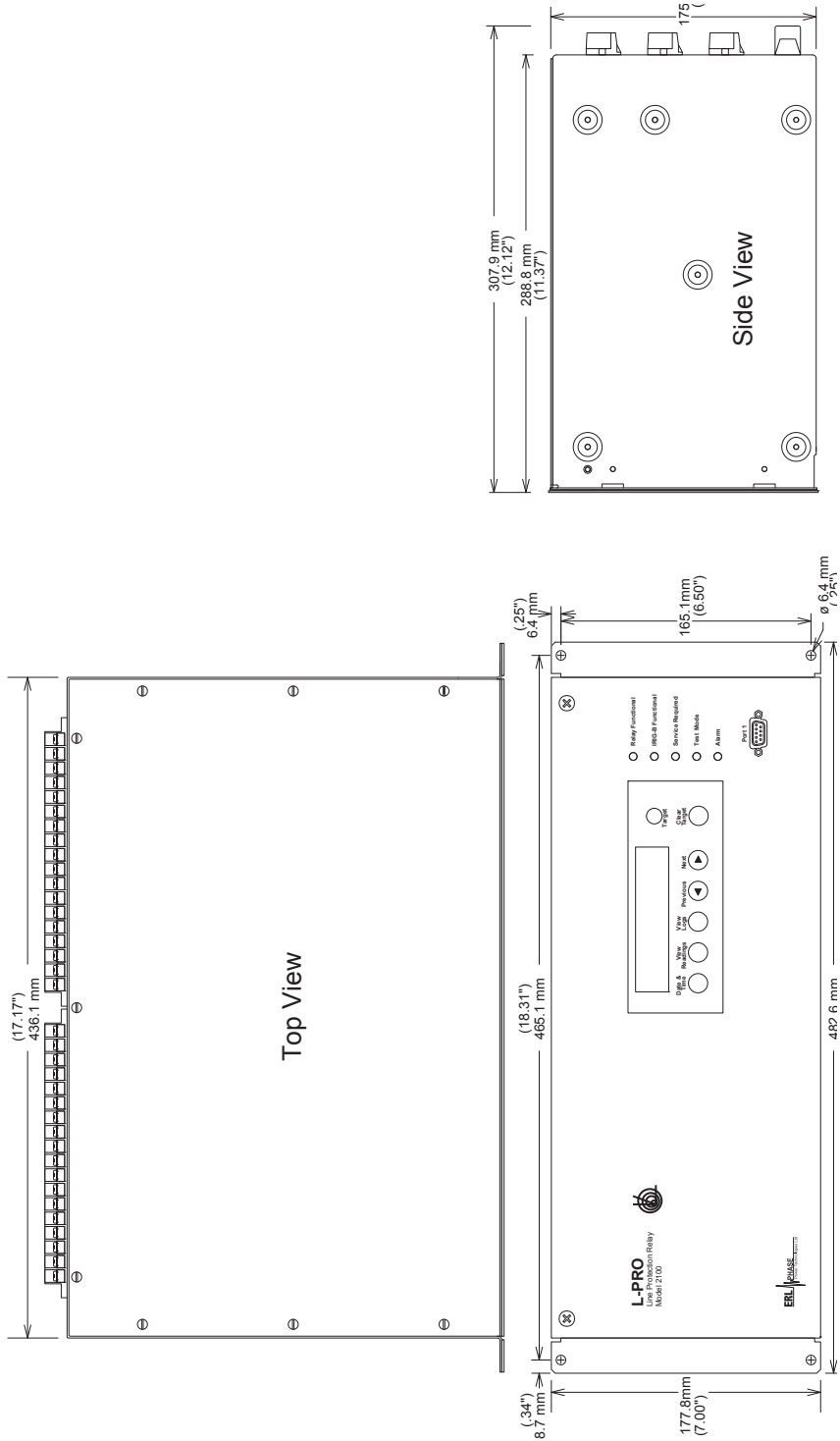

Figure G.3: Mechanical Drawing – 4U Chassis

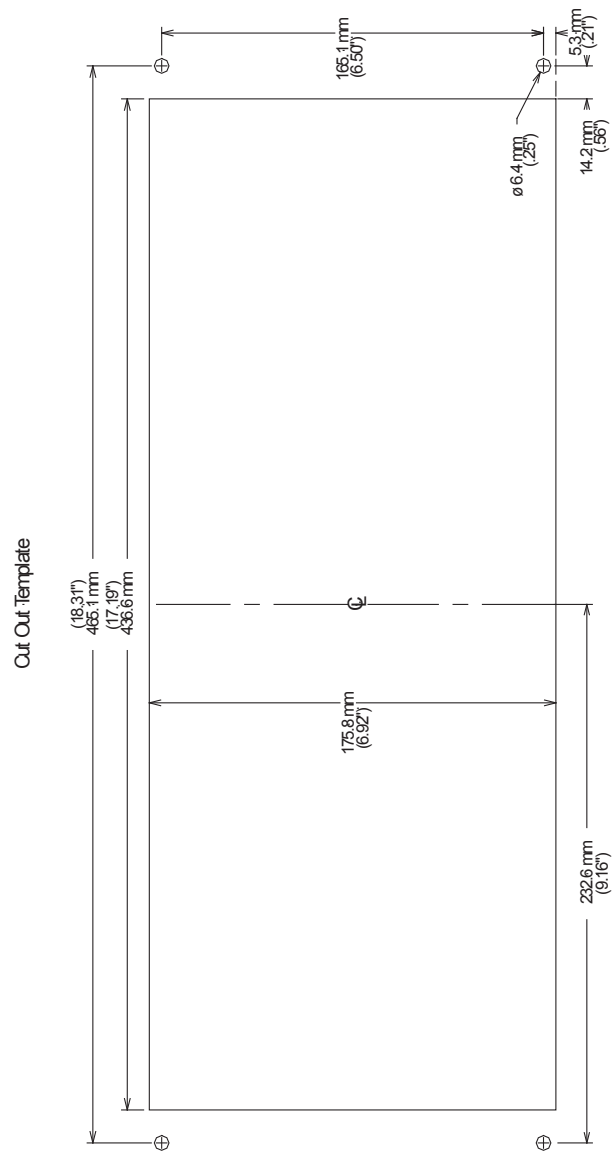

Figure G.4: Cut-out Template – 4U Chassis

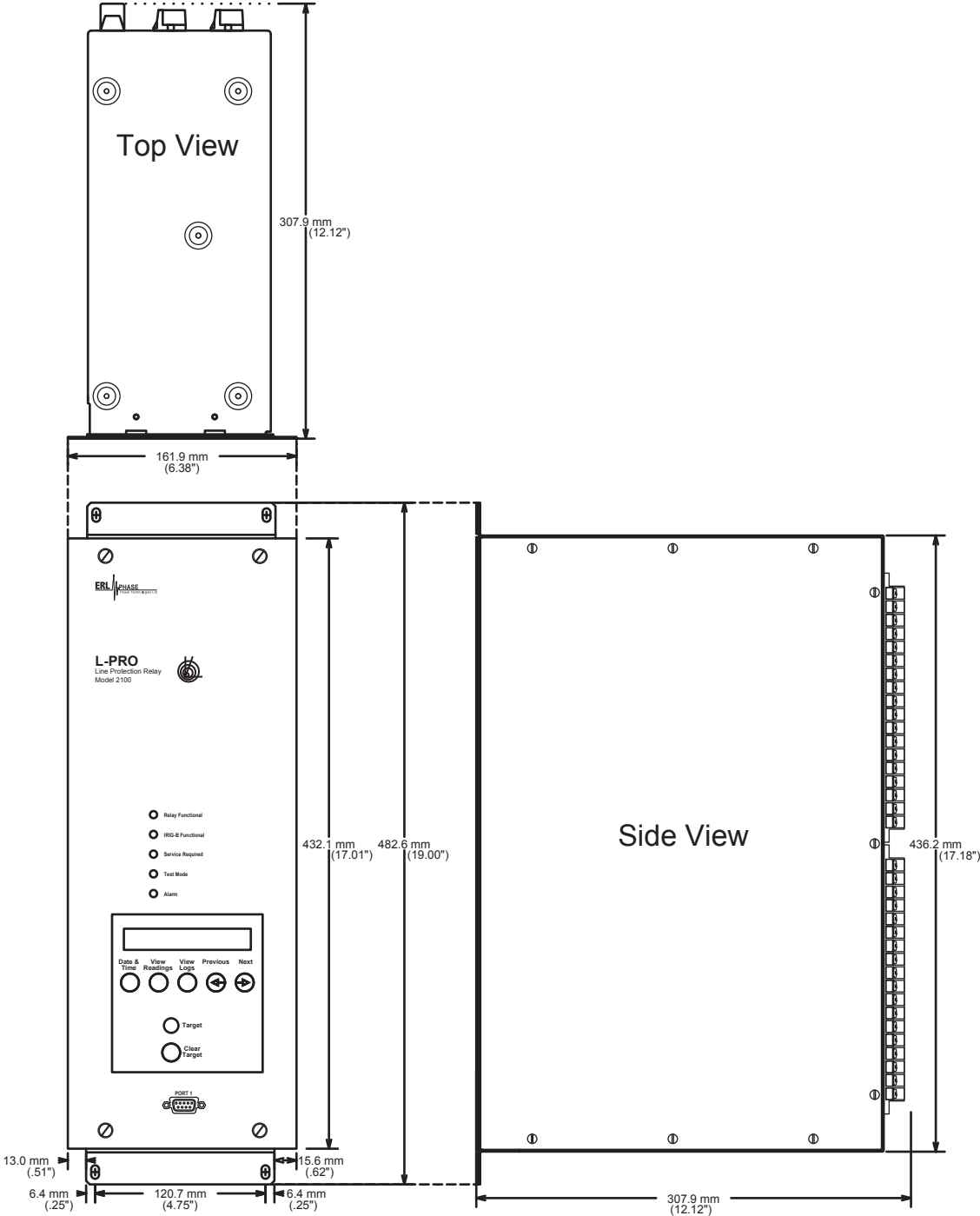

Figure G.5: Vertical Mount Mechanical Drawing – 3U Chassis

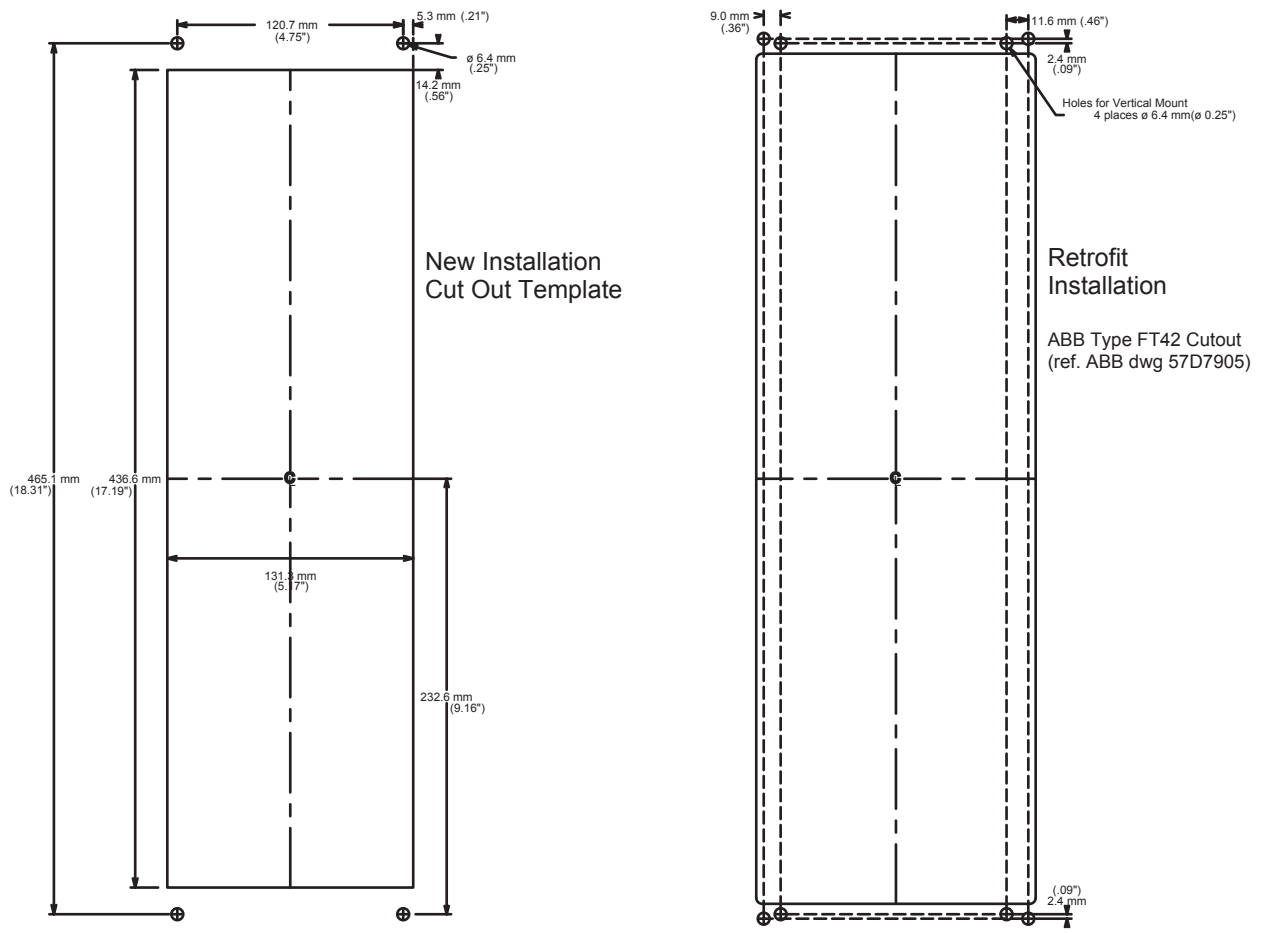

Figure G.6: Vertical Mount Cut-out Template – 3U Chassis



# Appendix H Rear Panel Drawings

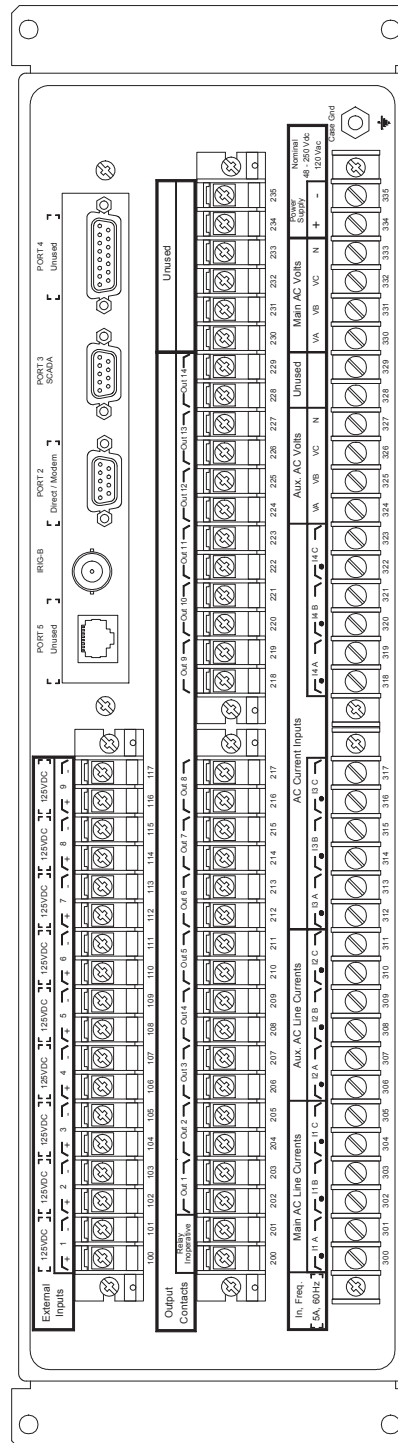

Figure H.1: Rear Panel – 3U Chassis

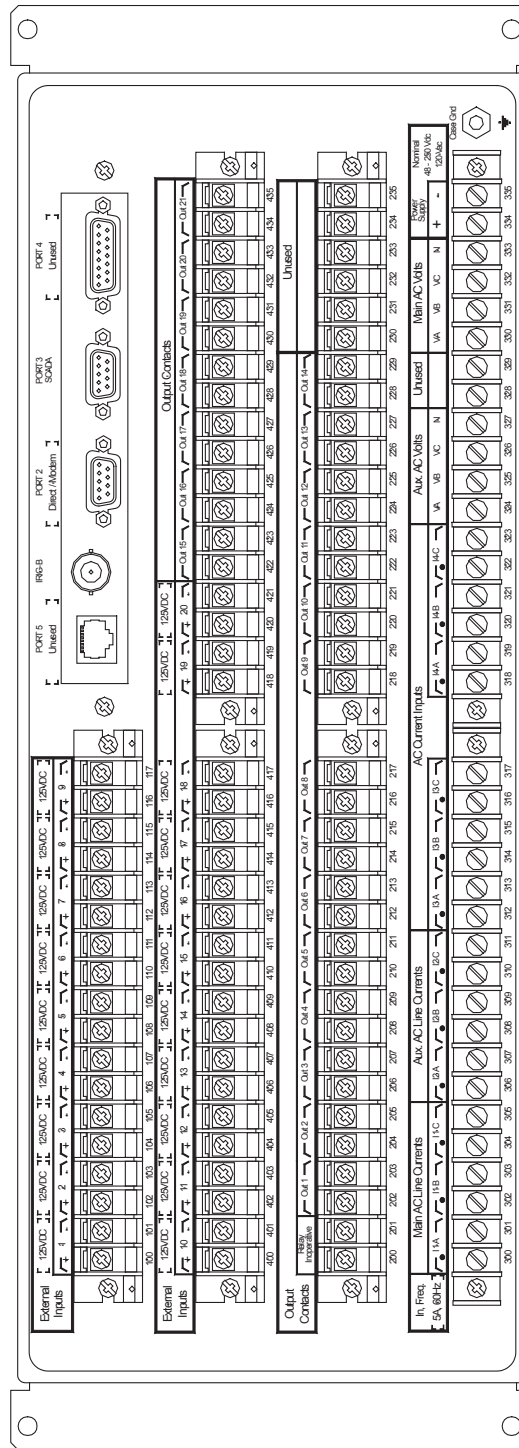

Figure H.2: Rear Panel – 4U Chassis

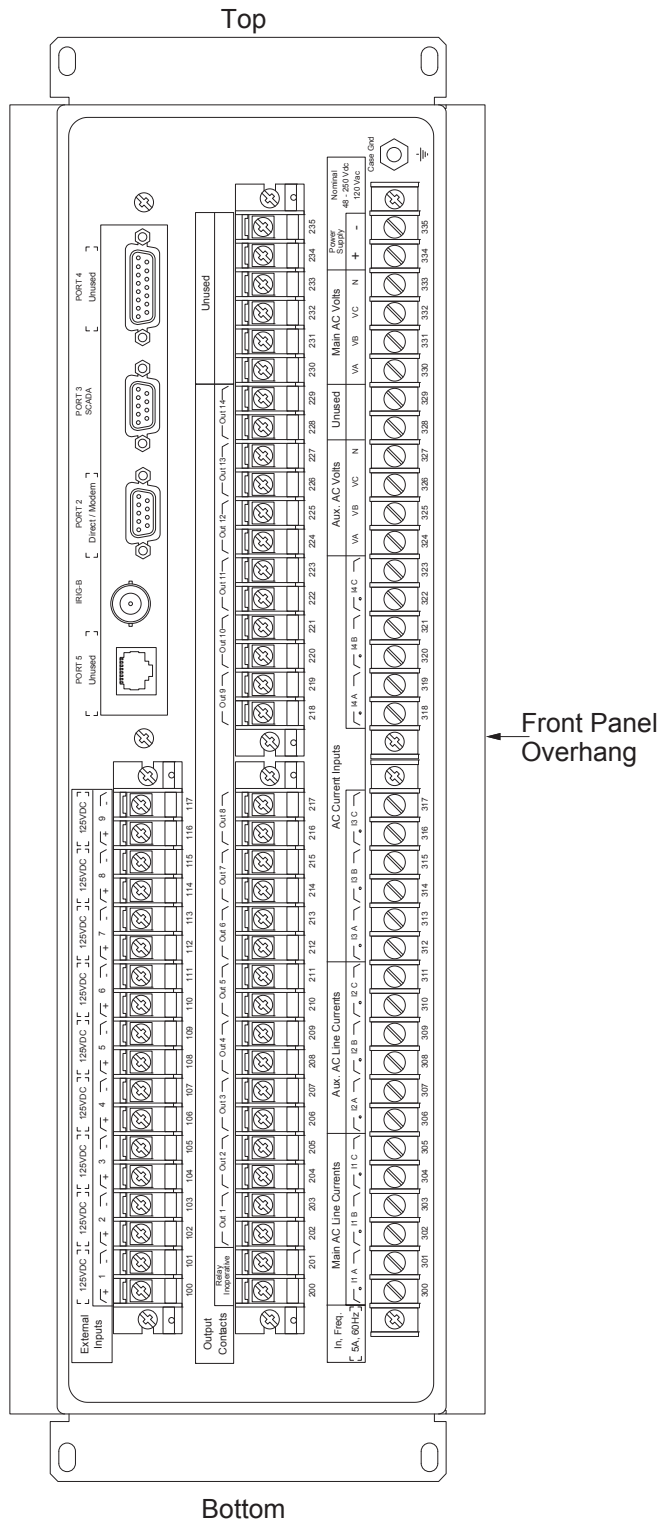

Figure H.3: Rear Panel - Vertical Mount – 3U Chassis



# Appendix I AC Schematic Drawings

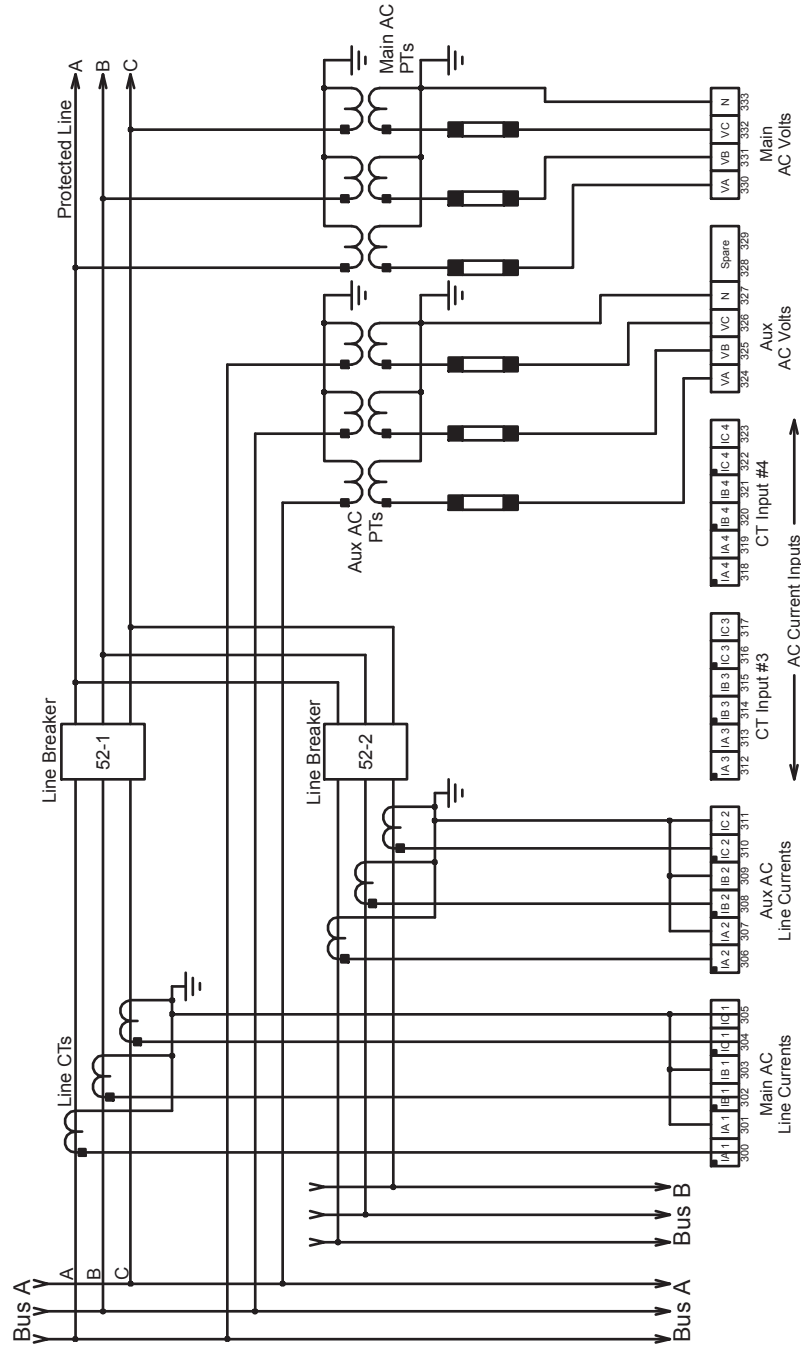

Figure I.1: L-PRO AC Schematic

**Notes:**

1. CT inputs 1 to be used for protection and for recording of the protected line.
2. CT inputs 2 can be used for second set of line currents for ring bus applications.
3. CT inputs 3 and 4 can be used for recording other AC currents.
4. AC Aux Voltage inputs used for line sync and over/under protection, main AC voltage inputs used for line protection.



# Appendix J DC Schematic Drawings

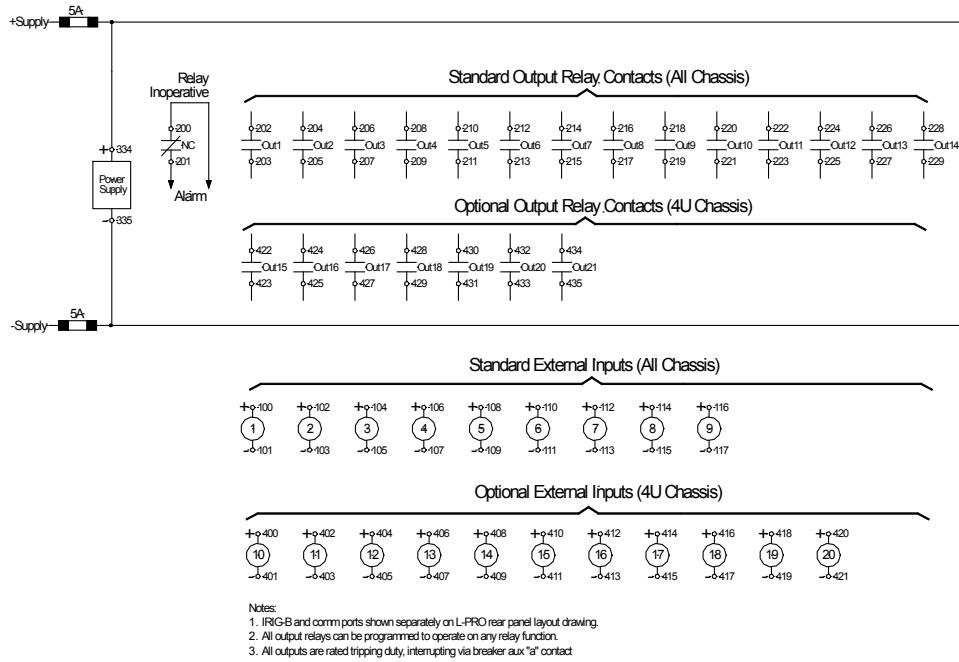

Figure J.1: L-PRO DC Schematic





---

# Appendix K Function Logic Diagram

Diagram in plastic sleeve.



---

# Appendix L L-PRO Setting Example

## Protection, Timers and I/O Status

The relay does not block any protection functions or external inputs during the setting save or active group change, but the external output contacts are reset for one cycle.

The relay applies the setting parameters, resets all protection functions, resets all timers and continues to process the protection algorithms but does not apply any action to the output contacts for one cycle. For close-in (heavy) fault conditions that occur at the time of a setting change the relay performance has a maximum increase in output delay of one cycle. For light fault conditions the relay performance does not have a noticeable change. There is normally a one cycle decision making process. The relay algorithms have been processing and when the one cycle blocking ends and the contacts are closed immediately (+3ms hardware delay).

## Latch Status

The relay does not reset any ProLogic, Group Logic or Virtual Input latch functions during the setting save or active group change. Retaining latch status allows the relay continuous access to specific latched logic states. This is useful when the relay has ProLogic, Group Logic or Virtual Input functions used to block protection or ancillary functions for specific operating conditions.

## Event Status Reset

The relay resets all the events that are currently high and reports states of all the events that remain high after a setting change.

## Viewing Active Setting Group

To view the active setting group and status of the group logic functions in real time via the terminal UI, enter the *Metering/Logic/Setting Group* menu choice. To view a snapshot of the group logic data, enter the *Settings/Active Group* menu choice.

## Front Panel Active Setting Group

View the active setting group with the relay front panel display. There is no capability to change active setting group with the front panel. The front panel displays 2 lines of data, the first line contains the “Active Setting Group: x”, where x is the current setting group and flashes. The second line of data displays the user-defined setting name for the current setting group.

To view the active setting group press the *Previous* or *Next* buttons to cycle through the time/date indication and the serial port settings.

## Flash Memory Write

The flash memory on the main processor board is capable of approximately one hundred thousand erases. The retention of the active setting group causes 2 bytes to be written to a memory block in the flash. Each memory block writes about 65 Kbytes before an erase is performed on the flash memory. An average of 14 setting group changes per day for the 25 year life of a relay results in the flash memory being erased only 4 times. Latch states from ProLogic and Group Logic also performs writes to the flash memory increasing the number of erases performed on the flash.

## Switching Setting Groups

You can program a total of 16 Group Logic statements per setting group to cause a setting change from one group to another. Create settings using the *Offliner* setting software or by using the Terminal Mode.

Some common uses for setting groups might be cold load pickup, Zone 1 and/or Zone 2 reach extension for phase and ground distance elements, zero sequence source increase or decrease.

An example of pulsing an external input and an example of a solid initiate to activate setting group changes are shown below.

### Using One External Input to Toggle Setting Group

Use one external input connected to a SCADA output contact to toggle between 2 or more setting groups. In this example we connect external input one (EI 1) to the SCADA control output contact and switch between group 1 and group 2. If you wanted to switch through all setting groups, group logic 2 would switch to setting group 3, and so forth. If the contact input to switch setting groups becomes welded shut or the SCADA system has a problem, the relay will only switch to the new logic and stay in that logic until the input has been de-energized for the ProLogic pickup delay, which was set to 10 seconds.

#### Setting Group 1 – Logic Statements

When setting group one becomes active either through a setting group change or is the default group after relay power up, ProLogic 9 becomes high after the 10.00 second delay, if EI 1 is low. ProLogic 9 is set for a 0.26 second dropout time; to be used with ProLogic 10 dropout timer allowing for the slower processing thread where Group Logic is processed and providing a definite timed pulse to the group logic.

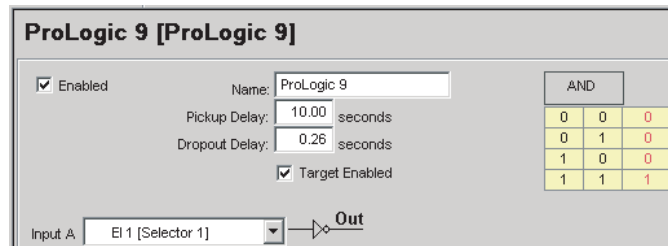

Figure L.1: ProLogic 9

ProLogic 10 has no intentional delay and becomes high for the combined drop-out time of ProLogic 9 and 10 equalling 0.52 seconds.

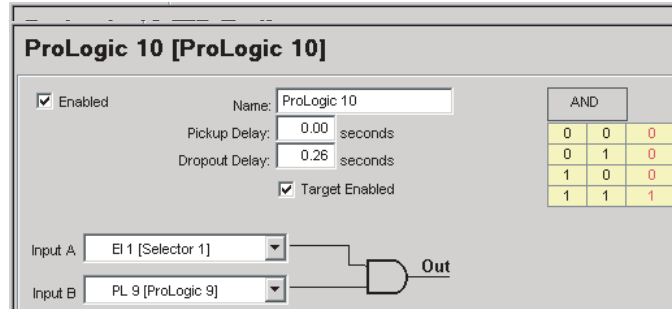

Figure L.2: ProLogic 10

Group Logic 1 is used to switch to the new setting group; there is no intentional delay. You can also provide 4 additional logic inputs to be used to provide qualifiers before switching setting groups. The example uses a ProLogic statement and an external input as qualifiers, see example “Using ProLogic to Qualify Group Logic Statements” in Appendix L’ on page Appendix L-8.

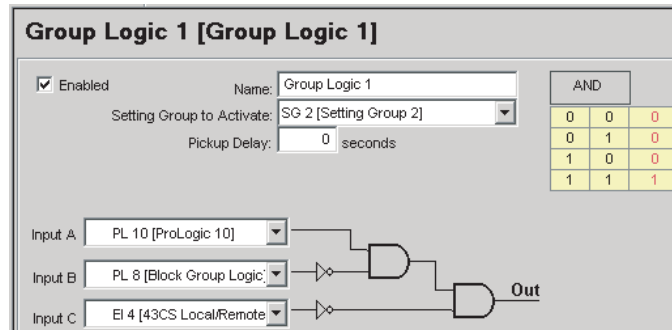

Figure L.3: Group Logic 1

### Setting Group 2 – Logic Statements

When setting group 2 becomes active either through a setting group change or is the default group after relay power up, ProLogic 9 becomes high after the 10.00 second delay, if external input one is low. The example shows ProLogic 9 set for a 0.26 second dropout time to be used with ProLogic 10 dropout timer allowing for the slower processing thread where Group Logic is processed and providing a definite timed pulse to the group logic.

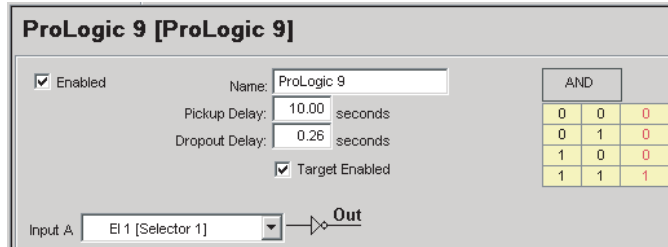

Figure L.4: ProLogic 9

Prologic 10 has no intentional delay and becomes high for the combined drop-out time of ProLogic 9 and 10 equalling 0.52 seconds.

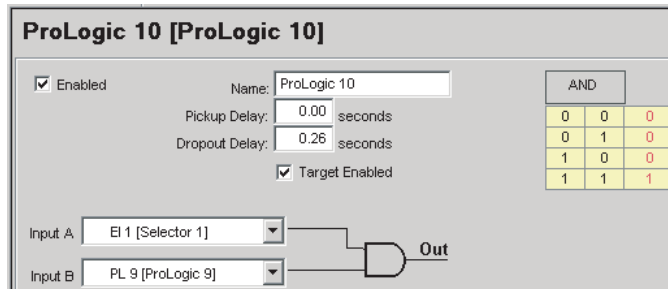

Figure L.5: ProLogic 10

Group Logic 1 is used to switch to the new setting group; there is no intentional delay.

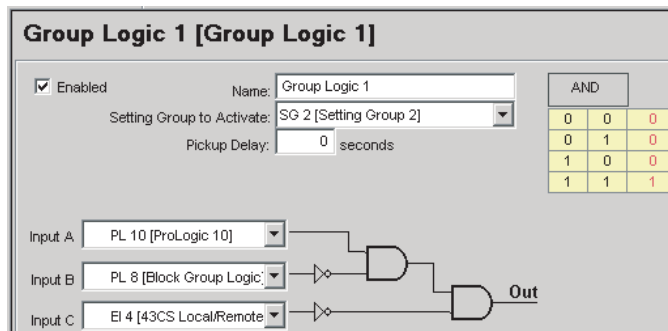

Figure L.6: Group Logic 1

### Using Three External Inputs to Toggle Setting Group

Three external inputs connected to an 8 position selector switch. The output contact is used to build a truth table to toggle between 8 setting groups. In this example we connect EI 1, EI 2, and EI 3 to the selector switch output contacts.

Selector Switch	Input States			Setting Group to Activate
	EI 3	EI 2	EI 1	
1	0	0	0	Setting Group 1
2	0	0	1	Setting Group 2
3	0	1	0	Setting Group 3
4	0	1	1	Setting Group 4
5	1	0	0	Setting Group 5
6	1	0	1	Setting Group 6
7	1	1	0	Setting Group 7
8	1	1	1	Setting Group 8

#### Setting Group 1...8 – Logic Statements

The following Group Logic statements are entered into each of the 8 setting groups.

When the selector switch is rotated to the appropriate position the corresponding setting group becomes active. Each setting group logic can have a specific time delay pickup setting. You can also provide 2 additional logic inputs in each statement to be used to provide qualifiers before switching setting groups. We are using a ProLogic statement and an external input as qualifiers, see “Using ProLogic to Qualify Group Logic Statements” in Appendix L’ on page Appendix L-8.

#### EI 1 low, EI 2 low, and EI 3 low

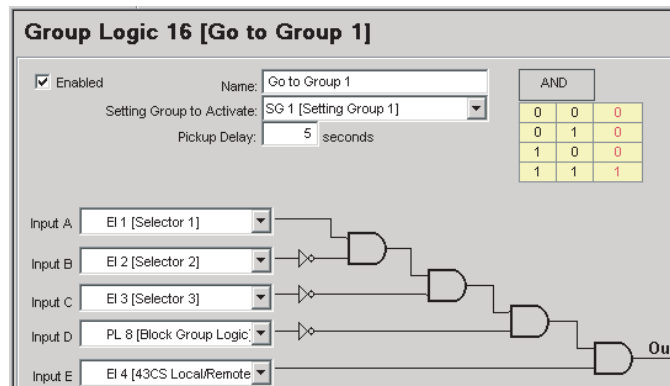

Figure L.7: Group Logic 16

**EI 1 high, EI 2 low, and EI 3 low**

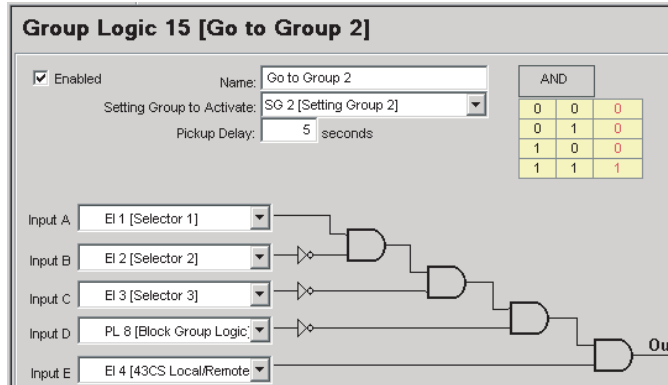

Figure L.8: Group Logic 15

**EI 1 low, EI 2 high, and EI 3 low**

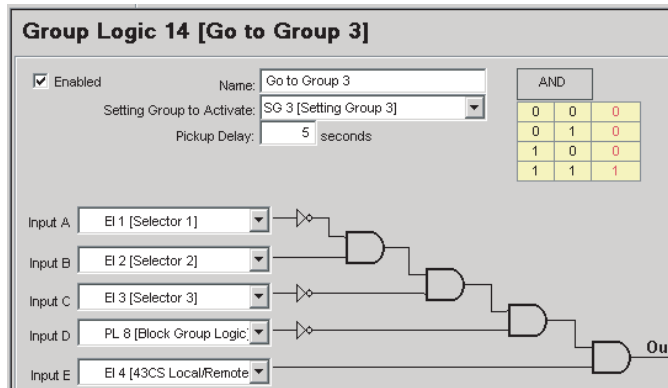

Figure L.9: Group Logic 14

**EI 1 high, EI 2 high, and EI 3 low**

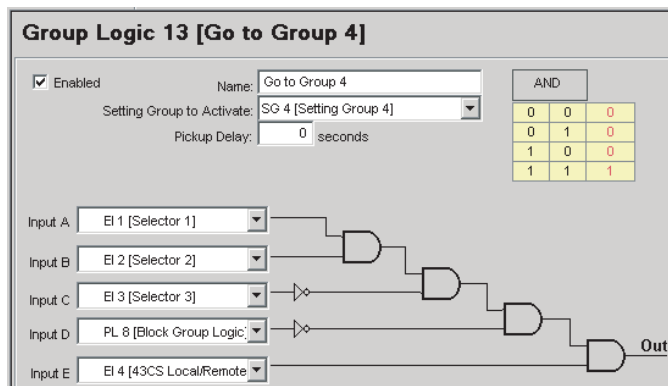

Figure L.10: Group Logic 13



**EI 1 low, EI 2 low, and EI 3 high**

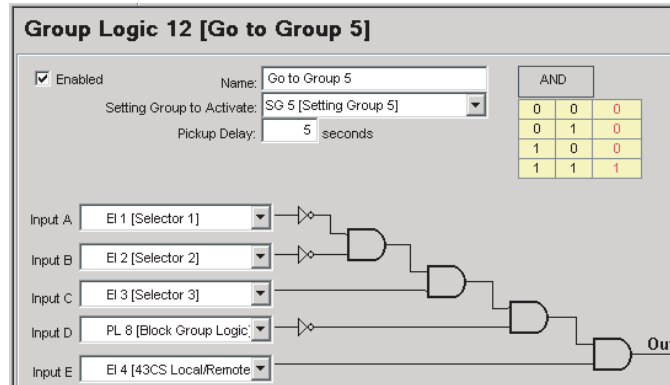

Figure L.11: Group Logic 12

**EI 1 high, EI 2 low, and EI 3 high**

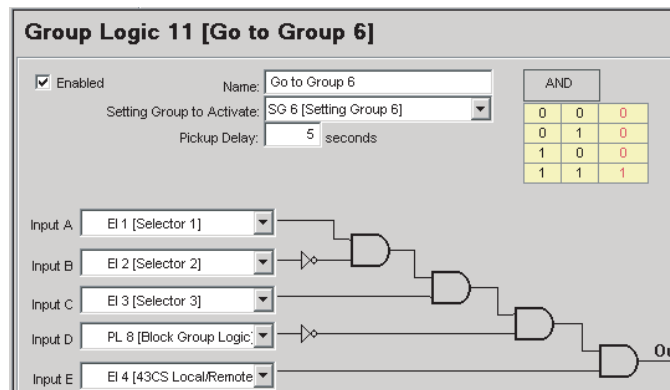

Figure L.12: Group Logic 11

**EI 1 low, EI 2 high, and EI 3 high**

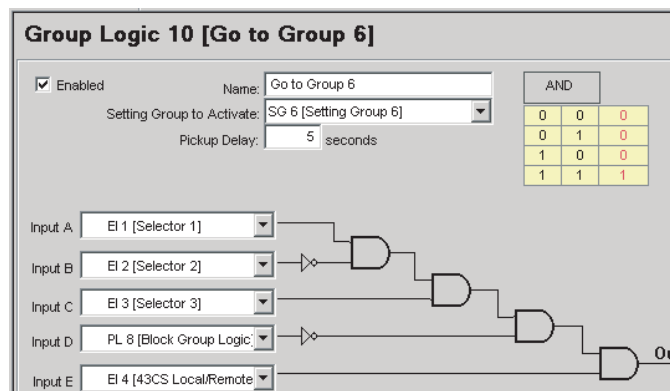

Figure L.13: Group Logic 10

### EI 1 high, EI 2 high, and EI 3 high

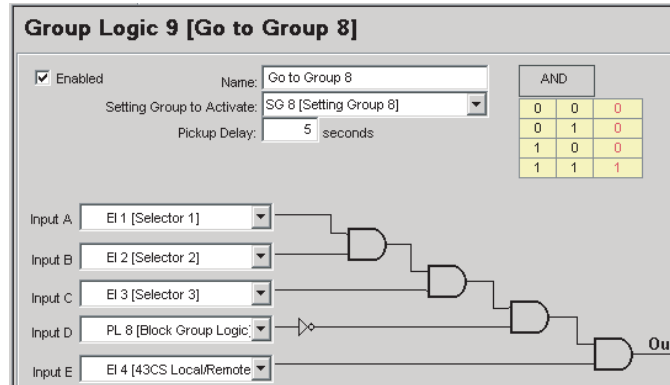

Figure L.14: Group Logic 9

### Using ProLogic to Qualify Group Logic Statements

You can select from any available ProLogic inputs to make specific blocking logic to be used as a qualifier for any group logic decisions. In this example we use either the zone 1 or zone 2 phase distance elements or the communications trip or the communications send or the Out of Step outer blinder alarm to drive the Block Group Logic statement. There is no intentional pickup delay and 0.5 second drop-out delay to hold the block on after the block condition has reset.

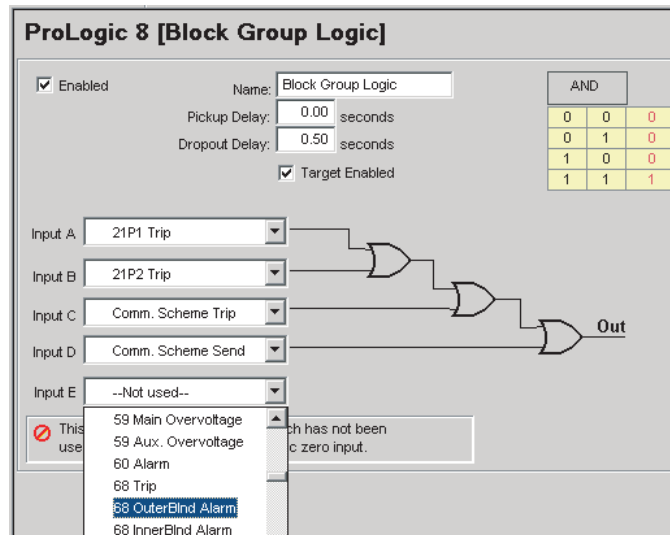

Figure L.15: ProLogic 8

## 79 Auto-recloser examples

You can program up to 4 shots or reclose attempts with the 79 function, with various lead and follow breaker options. Create settings by using the Offliner settings software or by using the terminal mode.

### 79 Recloser Settings

Figure L.16: 79 Recloser

Setting the recloser is all done in one screen.

In our example we are using one shot with an open interval of 10 seconds (T1) for the Main circuit breaker and a follow interval of 5 seconds (TF) for the auxiliary circuit breaker. This means that 10 seconds after both breakers open the main breaker will attempt to reclose and 5 seconds after the main breaker has closed the auxiliary breaker will attempt to close. The main and auxiliary close signal time is set to last for 0.5 seconds (TP). When the recloser receives an initiation signal that signal will stay high for an additional time of 1.0 seconds which allows the recloser to seal-in (TDI).

We are not using sync control in this example. If sync control was necessary the user only has to enable sync control and then set the appropriate settings in the 25/27/59 screen. For example if Dead Main Dead Auxiliary was selected the recloser would be blocked unless both main and auxiliary voltages are below 20 volts (positive sequence).

The recloser mode setting is related to the Ring Bus Configuration (auxiliary CT line input) and must match the breaker configuration in the system parameters screen.

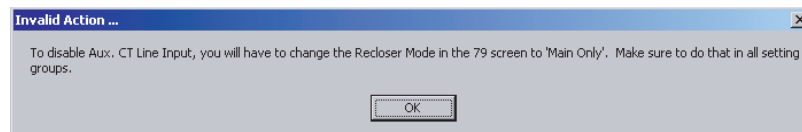

Figure L.17: Invalid Action

Most protection schemes require the ability to block the 79 when certain events happen. In our example we are using Virtual Input 7 (VI 7) to block. The 79 blocking is set to last for an additional time of 1.0 seconds (TDB).

79 initiation is done by simply setting the desired function in the output matrix.

Device	Output Contact														Block & Initiate			Recording	
	1	2	3	4	5	6	7	8	9	10	11	12	13	14	79B	79I	BFI	Fault	Swing
VI 1 [52-1 Close 52-CS]	✗																		
VI 2 [52-1 Trip 52-CS]																			
VI 3 [52-2 Close 52-CS]		✗																	
VI 4 [52-2 Trip 52 CS]																			
VI 5 [52-1, 52-2 Trip&79]			✗	✗															
VI 6 [Manual 79]																			
VI 7 [79CS Enable/Disable]																	✗		
VI 8 [SCADA 8]																			
VI 9 [SCADA 9]																			
VI 10 [SCADA 10]																			
VI 11 [SCADA 11]																			
VI 12 [SCADA12]																			
VI 13 [SCADA 13]																			
VI 14 [SCADA 14]																			
VI 15 [SCADA 15]																			
VI 16 [SCADA 16]																			
VI 17 [SCADA17]																			
VI 18 [SCADA 18]																			
VI 19 [SCADA 19]																			
VI 20 [SCADA 20]																			

Figure A.1: Output Matrix

The 79 can also automatically move the follow breaker into the lead position if the lead breaker has been out of service for an extended period of time. The out of service indication is also used to prevent reclosing attempts to the main or auxiliary breaker. In our example a breaker has to be opened and stay open for a time of 120.0 seconds (TC).

The 79 can also be configured with the follow breaker switch setting. In this example we are using the TF follow time of 5.0 seconds for the 2nd breaker open interval. The user can use the recloser reset time of TD by selecting the “close after recloser reset time” setting.

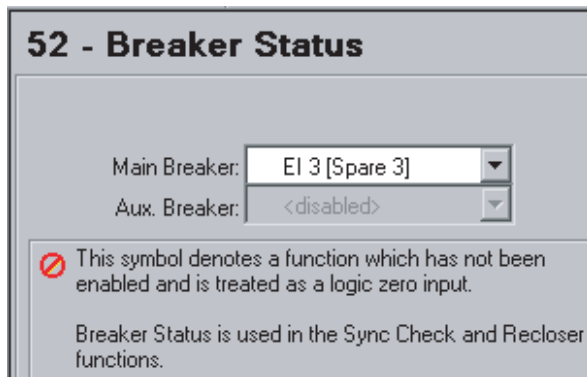

Figure L.18: Breaker Status

52 - Breaker Status can use any external input or ProLogic statement. The recloser does not have to be enabled for this logic to work. The 2 circuit breakers cannot share the same input.



Figure L.19: Invalid Selection

## Test Configuration

Examples to test the 79 functions using Virtual Inputs and ProLogic to simulate the reclose initiation and breaker contact “a” status are shown below.

Virtual Inputs are multi-use logic points that are accessed remotely via SCADA control and/or locally via the terminal user interface (UI).

We will set up 6 virtual inputs to trip and close each breaker and to initiate the 79. You could also use external inputs to provide the breaker “a”, trip, close, and initiate signals, but by using virtual inputs and ProLogic testing is quicker and does not require an external DC supply or relays to simulate the circuit breakers.

## Virtual Inputs

The Virtual Input (VI) names are used for descriptive purposes. This name will appear in the event log when the logic point becomes active. The L-PRO Relay supports 2 circuit breakers and in this example we will name the main circuit breaker 52-1 and the auxiliary circuit breaker 52-2. Virtual Inputs 1, 2, 3, and 4 will be used as control switches (CS) for tripping and closing while Virtual Input 7 will be used to enable or disable the 79. Virtual Input 5 is used to trip circuit breakers 52-1 and 52-2, and to provide recloser initiation. Virtual Input 6 is used to provide recloser initiation without any tripping (used to help test logic)

Virtual Input Names					
1	52-1 Close 52-CS	11	SCADA 11	21	Virtual Input 21
2	52-1 Trip 52-CS	12	SCADA12	22	Virtual Input 22
3	52-2 Close 52-CS	13	SCADA 13	23	Virtual Input 23
4	52-2 Trip 52 CS	14	SCADA 14	24	Virtual Input 24
5	52-1, 52-2 Trip&79	15	SCADA 15	25	Virtual Input 25
6	Manual 79	16	SCADA 16	26	Virtual Input 26
7	79CS Enable/Disable	17	SCADA17	27	Virtual Input 27
8	SCADA 8	18	SCADA 18	28	Virtual Input 28
9	SCADA 9	19	SCADA 19	29	Virtual Input 29
10	SCADA 10	20	SCADA 20	30	Virtual Input 30

Figure L.20: Virtual Inputs

### Main and Auxiliary Circuit Breaker Trip Logic

ProLogic statement 1 and 3 are used to provide a common tripping logic point for the circuit breaker this is analogous to creating a dc trip bus to gather the trip and no reclose or trip and reclose signals. VI2 and VI4 are (VI2 for main and VI4 for auxiliary) the trip and no reclose while VI5 is the trip and reclose (common to main and auxiliary) signal.

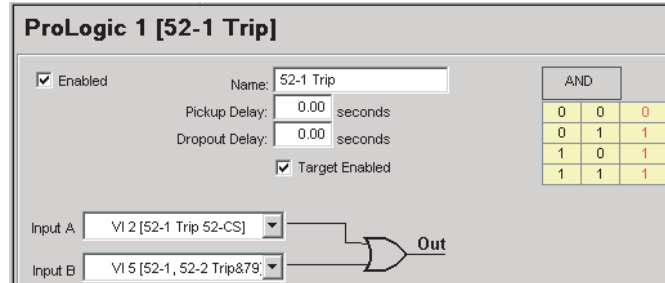

Figure L.21: ProLogic 1 – 52-1 Trip

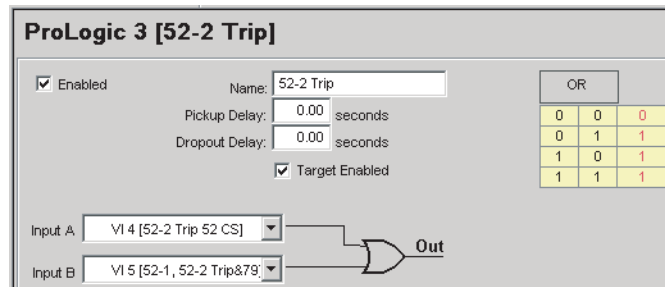

Figure L.22: ProLogic 3 – 52-2 Trip

### Circuit Breaker Simulator Logic

ProLogic statement 2 and 4 are used to provide a simulated logic point for the circuit breaker contact “a” status. The output of this logic is used as the input for the 52 - Breaker Status (see 79 Recloser Settings). The 79 Main Reclose logic point and VI1 provide the close signal ProLogic 1 provides the trip signal. The pickup and dropout time delays are used to simulate breaker tripping and closing times.

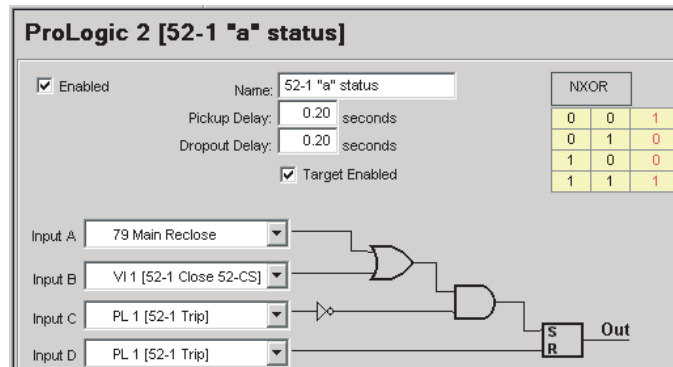

Figure L.23: ProLogic 2 – 52-1 “a” Status

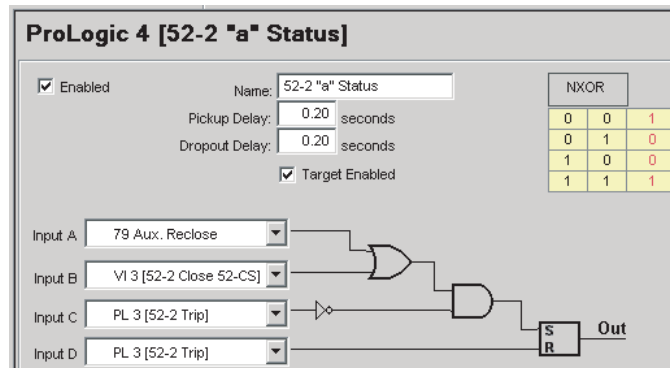
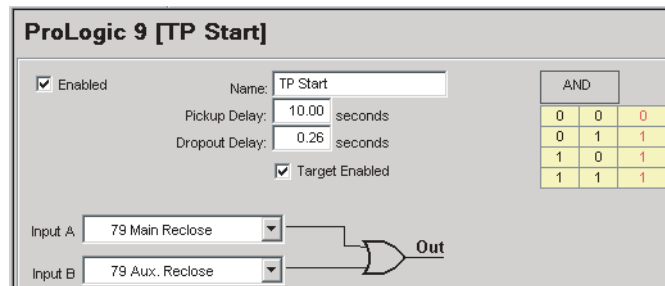

Figure L.24: ProLogic 4 – 52-2 “a” Status

**Testing The 79 Recloser**

- 1 Apply the previous settings to the relay.
- 2 Set PL9 to:



- 3 Set PL10 to:

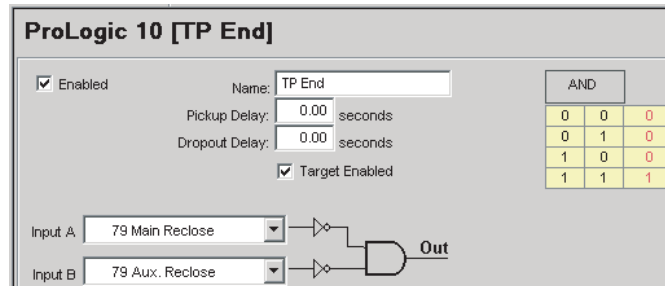

- 4 Set PL6 to:
  - (used for monitoring purposes)

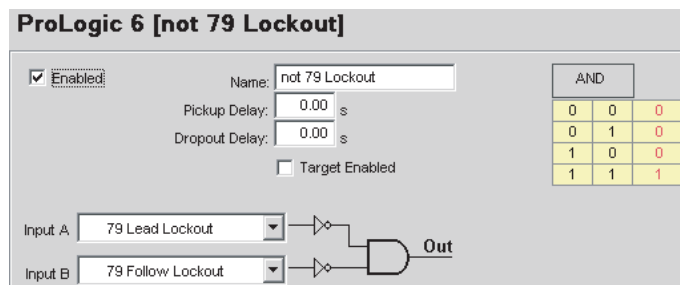

- 5 Clear the event log.

6 Check the metering screen for ProLogic. 52-1 and 52-2 should be low.

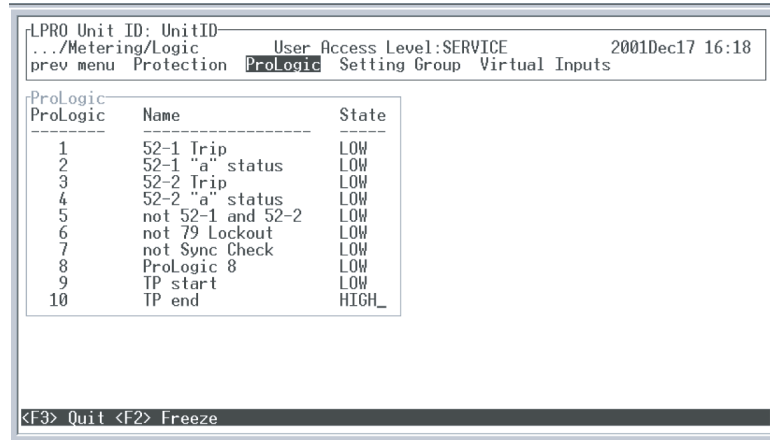

7 Check the metering screen for Protection. All 79 logic points should be low.

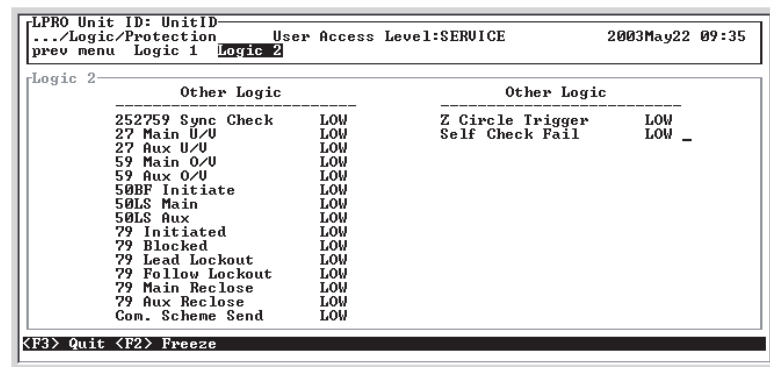

8 Go to the Control Virtual Inputs and “close” 52-1 and 52-2 using the Pulse On action for the virtual inputs. This will activate ProLogic 2 and 4.

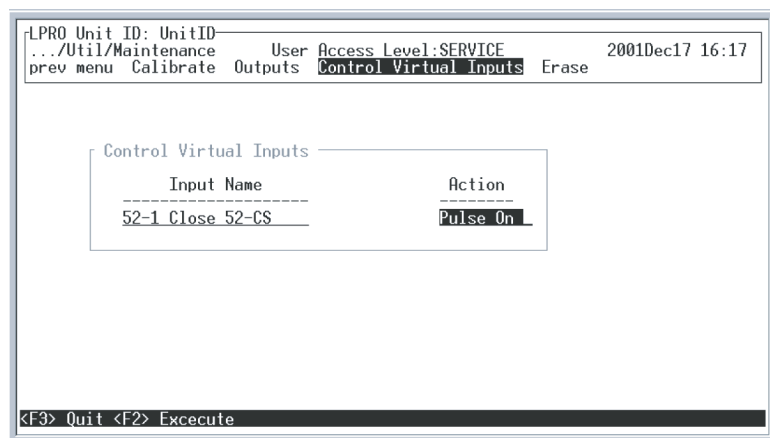



## 9 Check the event log for VI1 and VI3 along with PL2 and PL4.

```

LPRO Unit ID: UnitID
Main Menu      User Access Level:SERVICE      2003May22 09:34
ID Settings Metering Records Event Log Utilities Access Quit
-----
Event Log
TIME          EVENT
-----
2003May22 09:33:35.000 52-2 "a" status:PL4
2003May22 09:33:27.864 52-2 Close 52-CS:U13 : High
2003May22 09:33:11.000 52-1 "a" status:PL2
2003May22 09:33:02.439 52-1 Close 52-CS:U11 : High
-----
F3 Quit, C-UP & C-DOWN move one line, U page up, D page down, T Top, B Bottom

```

## 10 Go to the Control Virtual Inputs and select “Manual 79 I” using the Pulse On action for the virtual inputs. This will initiate the recloser but no action will be taken because the circuit breakers remain closed.

```

LPRO Unit ID: UnitID
.../Util/Maintenance User Access Level:SERVICE      2001Dec17 16:23
prev menu Calibrate Outputs Control Virtual Inputs Erase
-----
Control Virtual Inputs
-----
Input Name          Action
-----
Manual 79I         Pulse On
-----
<F3> Quit <F2> Execute

```

## 11 Check the event log and confirm there was no reclosure action.

```

LPRO Unit ID: UnitID
Main Menu      User Access Level:SERVICE      2003May22 09:43
ID Settings Metering Records Event Log Utilities Access Quit
-----
Event Log
TIME          EVENT
-----
2003May22 09:41:48.000 79 Initiated: High
2003May22 09:41:17.531 Manual 79I:U16 : High
2003May22 09:41:03.000 52-2 "a" status:PL4
2003May22 09:40:55.231 52-2 Close 52-CS:U13 : High
2003May22 09:40:41.000 52-1 "a" status:PL2
2003May22 09:40:31.731 52-1 Close 52-CS:U11 : High
-----
F3 Quit, C-UP & C-DOWN move one line, U page up, D page down, T Top, B Bottom

```

- 12 Go to the Control Virtual Inputs and select “52-1, 52-2 Trip&79I” using the Pulse On action for the virtual inputs. This will trip both breakers and initiate the reclosing sequence.

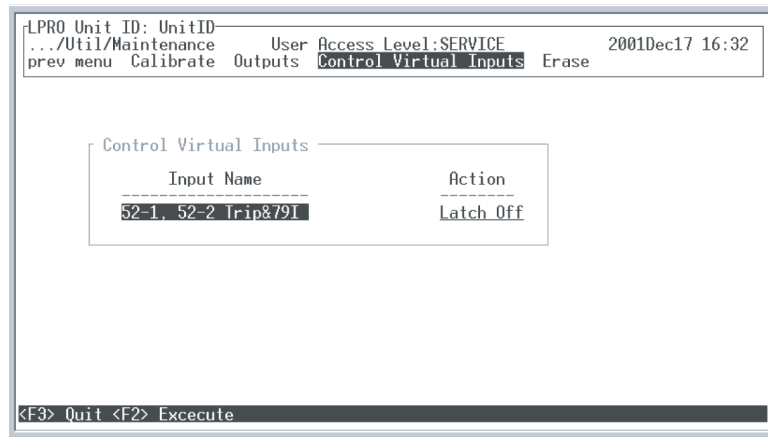

- 13 Check the event log and confirm that 52-1 was the first breaker and 52-2 was the second breaker. Check open interval time and follower time, the close pulse can be measured from the time between PL9 and PL10 going high.
  - T1 - Open interval time equals time from 79 Initiate event to 79 Main Reclose (shot 1) event.
  - TP - Close pulse time equals time from TP start: PL9 event to TP end: PL10 event.
  - TF - Follow breaker time equals time from 52-1 “a” status: PL2 event to 79 Auxiliary Reclose (shot 1) event.

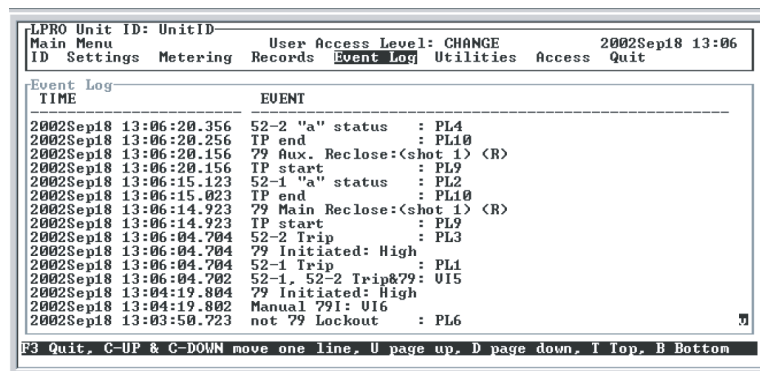

- 14 Go to the Control Virtual Inputs and select “52-1 Trip 52-CS” using the Pulse On action for the virtual inputs. This will trip breaker 52-1 and after timer TC, 52-2 (follow breaker) will move into the lead position.
- 15 Go to the Control Virtual Inputs and select “52-1, 52-2 Trip&79I” using the Pulse On action for the virtual inputs. This will trip breaker 52-2 and initiate the reclosing sequence.

- 16 Check the event log and confirm that only 52-2 breaker reclosed and was in the lead position. Confirm that 52-1 breaker did not receive any reclose attempts.

```

LPRO Unit ID: UnitID
Main Menu      User Access Level: SERVICE      2001Dec17 17:10
ID Settings Metering Records Event Log Utilities Access Quit

Event Log
-----
TIME          EVENT
-----
2001Dec17 17:09:24.481 52-2 "a" status: PL4
2001Dec17 17:09:24.231 TP end: PL10
2001Dec17 17:09:23.731 79 Aux. Reclose (shot 1)
2001Dec17 17:09:23.731 TP start: PL9
2001Dec17 17:09:13.504 79 Initiate
2001Dec17 17:09:13.504 52-2 Trip: PL3
2001Dec17 17:09:13.504 52-1 Trip: PL1
2001Dec17 17:09:13.502 52-1, 52-2 Trip&79: VI5
2001Dec17 17:05:33.464 52-1 Trip: PL1
2001Dec17 17:05:33.462 52-1 Trip 52-CS: VI2
2001Dec17 16:34:48.646 52-2 "a" status: PL4
2001Dec17 16:34:48.396 TP end: PL10
2001Dec17 16:34:47.896 79 Aux. Reclose (shot 1)
2001Dec17 16:34:47.896 TP start: PL9
2001Dec17 16:34:42.879 52-1 "a" status: PL2

```

F3 Quit, C-UP & C-DOWN move one line, U page up, D page down, T Top, B Bottom

- 17 Go to the Control Virtual Inputs and select “52-1 Close 52-CS” using the Pulse On action for the virtual inputs. This will close breaker 52-1 and after a fixed delay of 10.0 seconds breaker 52-1 will move back into the lead position and 52-2 (follow breaker) will move back into the follow position.
- 18 Go to the Control Virtual Inputs and select “52-1, 52-2 Trip&79I” using the Pulse On action for the virtual inputs. This will trip both breakers and initiate the reclosing sequence.
- 19 After 52-1 closes and before 52-2 closes select “52-1, 52-2 Trip&79I” using the Pulse On action for the virtual inputs. This will trip breaker 52-1 and cause a lockout alarm to be generated and block the follow breaker reclose attempt.
- 20 Check the event log and confirm the 79 Lead Lockout event and that there was no follow breaker reclose attempt.
- 79 Lead Lockout - The time equals time from 79 Initiate event to 79 Lead Lockout event (approx. TP + 1.0s).

```

LPRO Unit ID: UnitID
Main Menu      User Access Level: CHANGE      2002Sep18 13:11
ID Settings Metering Records Event Log Utilities Access Quit

Event Log
-----
TIME          EVENT
-----
2002Sep18 13:11:12.823 79 Lead lockout: High
2002Sep18 13:11:11.608 79 Initiated: High
2002Sep18 13:11:11.608 52-2 Trip : PL3
2002Sep18 13:11:11.608 52-1 Trip : PL1
2002Sep18 13:11:11.606 52-1, 52-2 Trip&79: U15
2002Sep18 13:11:08.123 52-1 "a" status : PL2
2002Sep18 13:11:08.023 TP end : PL10
2002Sep18 13:11:07.923 79 Main Reclose:(shot 1) <R>
2002Sep18 13:11:07.923 TP start : PL9
2002Sep18 13:10:57.704 79 Initiated: High
2002Sep18 13:10:57.704 52-2 Trip : PL3
2002Sep18 13:10:57.704 52-1 Trip : PL1
2002Sep18 13:10:57.702 52-1, 52-2 Trip&79: U15

```

F3 Quit, C-UP & C-DOWN move one line, U page up, D page down, T Top, B Bottom

- 21 Go to the Control Virtual Inputs and select “52-1 Close 52-CS” using the Pulse On action for the virtual inputs. This will close breaker 52-1 and after a fixed delay of TD seconds the recloser will reset.

### Communication-aided Tripping Schemes

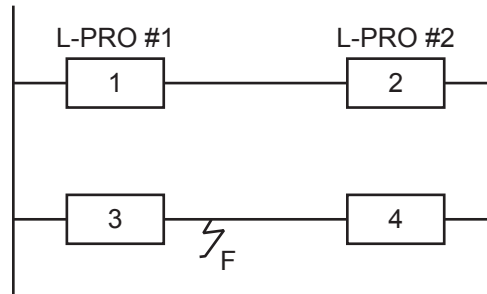

Figure L.25: Current Reversal Logic example

### Current Reversal Logic example

L-PRO Relays are installed and provide line protection by the tripping Breaker #1 and Breaker #2 respectively. A ground fault occurs at location F in the parallel line. Initially, 21N2 of L-PRO #2 picks up and sends a permissive transfer trip signal to L-PRO #1. Since L-PRO #1 detects a reverse fault (21N4 picks up), it neither trips the breaker nor sends a permissive transfer trip signal. When breaker #3 opens due to a zone 1 trip, the current reversal condition occurs on L-PRO #1. If the 21P2 on L-PRO #1 operates, and if the received permissive transfer trip signal from L-PRO #2 still exists the POTT scheme on L-PRO #1 will trip breaker #1. To prevent this unwanted tripping on the parallel line, the L-PRO relay has current reversal logic. The L-PRO current reversal logic prevents the false trip during this current reversal condition. Gate #116 of the functional logic diagram and timer TL1 and TD1 stretch the zone 4 logic and block the POTT scheme from tripping the breaker or sending the transfer trip signal to the remote end.

### Communication-aided Tripping Scheme Timer Considerations

The basic selection does not provide any communication-aided logic for local or remote protections.

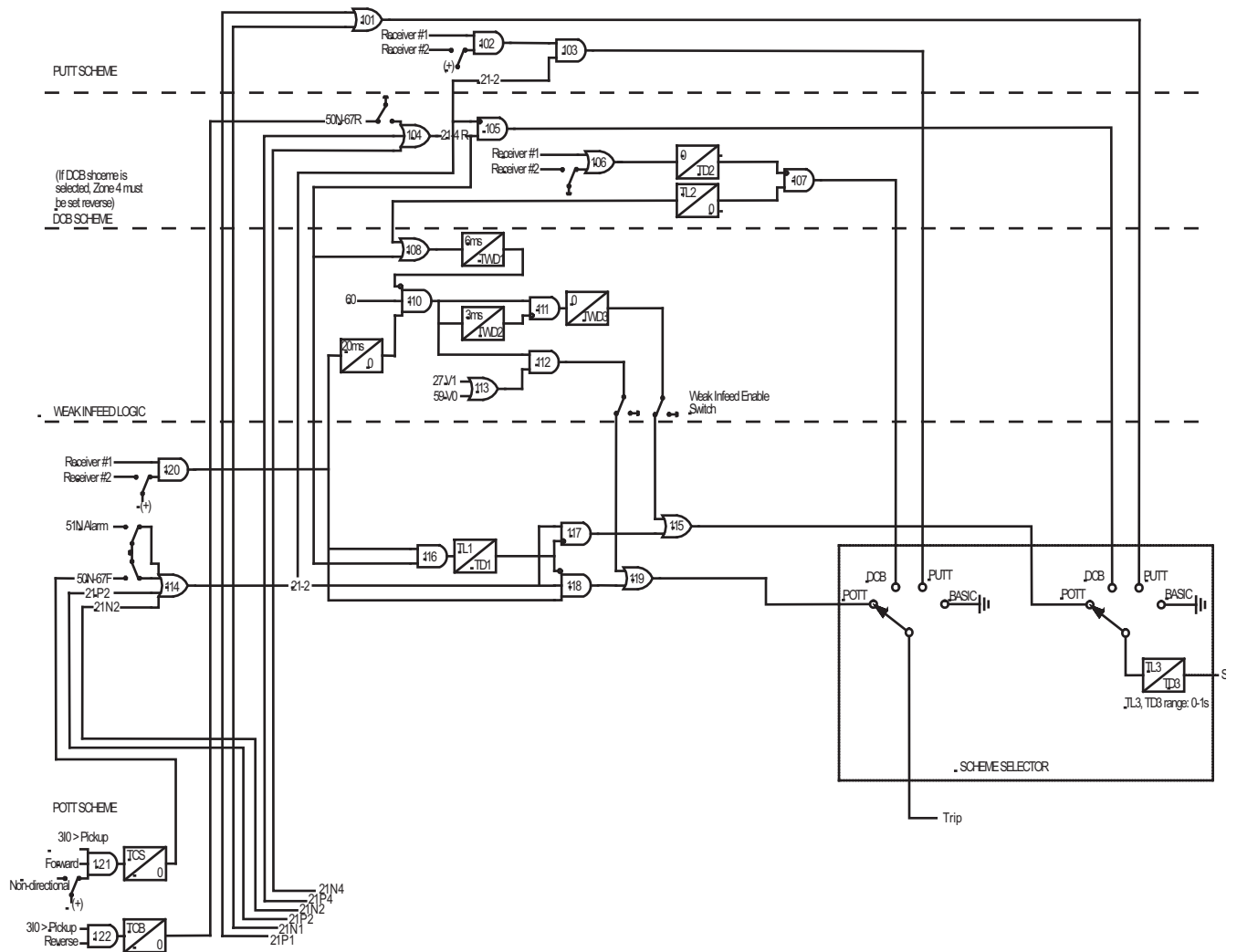

Figure L.26: Communication-aided Scheme

## L-PRO Scheme Timers Summary

<b>DCB Scheme Timers</b>	
<b>Timer</b>	<b>Considerations</b>
TD2	<p>Upon receipt of a Blocking Signal at the local end from the remote end, TD2 extends the Blocking Signal to prevent a Scheme Trip.</p> <p>The Blocking Signal should be extended by:            Time for the local 21-2 to de-assert (~1 cycle) –            Blocking Signal Channel Reset Time (i.e. the time for the removal of the Block to propagate from the remote end to the local end) + Security Margin*.</p>
TL2	<p>Delays the local 21-2 from producing a Scheme Trip for at least as long as it would take a Blocking Signal to arrive from the remote end.</p> <p>Should be set longer than the remote end 21-4R (OR 50-67R) detection time (~1 cycle) + Blocking Channel Time + Security Margin*.</p>

<b>POTT Scheme Timers</b>	
<b>Timer</b>	<b>Considerations</b>
TL1	<p>TL1 is intended for Parallel Line applications**:            Delays or prevents scheme trip upon detection of a current reversal at the local end.</p> <p>Time Delay should be set to less than: Remote End 21-2 Detection Time (~25msec) + Total End to End Channel Time</p>
TD1	<p>Also for Parallel Line Applications**:            Extends current reversal blocking of the Scheme Trip and Send.</p> <p>Should be set such that it will not block the local relay if the fault becomes forward and internal. However it needs to be set long enough to allow the permissive trip from the remote end to de-assert in the event that the remote fault reverses (remote external reverse fault).</p> <p>So, set local TD2 to: Remote 21-2 Reset Time + Channel Reset Time + Security Margin*.</p>

Scheme Selector Timers	
Timer	Considerations
TL3	Local fault duration must be greater than this time in order to produce a Scheme Send. POTT and PUTT = Permissive Trip DCB = Block Signal (derived from 21-4R (OR 50N-67R) AND NOT 21-2)
TD3	Stretches the Scheme Send signal to ensure that it's received by the remote end relay. Set longer than the channel pickup delay.

**Notes:**

\* Security Margin = 0.5 to 1 cycle or a percentage of total expected time to account for errors in scheme timing assumptions.

\*\* Parallel Line applications: fault contribution can come from unfaulted line appearing as a Zone 2 fault at one end and zone 4 reverse fault at the other end. Depending on the location of the fault on the faulted line and which breaker clears first, the current may change direction and the 2 terminals on the unfaulted line may change state from forward to reverse and reverse to forward. The unfaulted line contribution may come either end on a networked system.





---

# Index

## Numerics

21N ground distance 4-1  
21P phase distance 4-1  
25/27/59 sync check 4-28  
46/50/51/67 negative sequence  
overcurrent 4-31  
50/51/67 phase overcurrent 4-29  
50BF breaker failure 4-28  
50LS low set overcurrent 4-29  
50N/51N/67 neutral overcurrent 4-30,  
5-21  
59 overvoltage 4-22, 4-23  
60 loss of potential 4-32, 5-21  
68 out of step 4-32  
79 recloser 4-20  
81 frequency 4-26  
81 over/under frequency 5-21

## A

ac and dc wiring 7-1  
access 3-15  
active group 3-11  
alarm 3-3  
analog input 3-11, 5-7

## B

backward compatibility 5-4  
Base MVA 5-13  
Baud rate  
    direct serial link 2-7  
    modem link 2-7

## C

calibrate 3-14, 6-2  
calibration 6-2  
change 3-15  
circuit breaker simulator L-12  
clear target 3-3  
communication  
    direct serial link 2-2  
    modem link - external 2-3  
    modem link - internal 2-4  
    network link 2-4  
    relay 2-2  
communication port 2-9  
communication wiring 7-1  
communication-aided scheme 4-40,  
L-18  
creating a setting file from an older  
version 5-4  
CT turns ratio 5-13

## D

date & time 3-3  
DCB logic 4-43  
dead line pickup 4-17  
diagnostics 3-14  
display 3-4

## E

erase 3-14  
event log 3-13, 4-47  
external input 3-11, 5-8

## F

fault locator 4-33  
front display 3-1, 3-2, 3-4

## G

grounding 2-1  
group logic 4-34, 4-35, 5-21, L-8

## H

HyperTerminal 2-5

## I

ID 3-10, 3-11  
identification 5-6  
initiate swing recording 3-13  
initiate transient recording 3-13  
inputs  
    external 1-4  
    IRIG-B time 2-1  
installation  
    software 5-2  
IP address 2-13  
IRIG 3-2  
IRIG-B time input 2-1

## L

LED lights 3-2  
line parameters 5-17  
list 3-13  
logic 3-12

## M

maintenance 2-12, 3-14  
maintenance menu 2-12  
metering 3-12, 3-16  
mho  
    characteristic shapes 4-2, 6-6  
    phase and ground 4-1  
Modbus 3-14  
modem link 2-7

---

## O

Offliner settings 3-1, 5-1  
output contact 3-14, 5-9  
output matrix 5-22  
output relay contacts 1-4

## P

parameters  
  line 5-17  
  system 5-12  
password 3-7, 3-15  
physical mounting 7-1  
ports 3-14  
POTT logic L-19  
power supply 2-1  
ProLogic 5-21  
protection functions 4-1, 5-20  
  graphing 5-20  
PT turns ratio 5-13  
push buttons 3-3  
PUTT logic 4-44  
PUTT scheme 5-19

## Q

quadrilateral 4-5, 6-6  
quit 3-16

## R

recloser L-9  
record  
  duration and extension 4-46  
  initiation 4-46  
  length 5-16  
  storage, retrieval and analysis 4-46  
RecordBase View software 5-5  
recording 4-45  
  swing 4-45  
records 3-13  
relay functional 3-1, 3-2  
retrieve to Offliner 3-12

## S

SCADA 3-14  
  accessing 2-8  
  communication parameters 2-8  
  diagnostics 2-8  
  monitor 2-13  
  protocol selection 2-8  
scheme selector 5-19  
service 3-2  
setting group  
  change 6-25  
setting groups 3-11, 5-11, 5-17, L-2  
settings 3-11  
setup 3-14  
start-up 3-1

system parameters 5-12  
system requirements  
  hardware 5-1  
  operating system 5-1

## T

terminal mode 3-5  
test mode 3-1, 3-2  
testing  
  21N2 ground distance 6-18  
  21P1 phase distance 6-11  
  21P2 phase distance 6-13  
  25/27/59 sync check 6-44  
  27 undervoltage 6-26  
  46-50/46-51 negative sequence  
    overcurrent 6-34  
  50/51 phase overcurrent 6-31  
  50BF breaker fail 6-38  
  50LS low set overcurrent 6-38  
  50N/51N neutral overcurrent 6-29  
  59 overvoltage 6-28  
  60 loss of potential 6-10  
  68 out of step 6-23  
  79 recloser 6-46  
  81 overfrequency 6-41  
  81 underfrequency 6-41  
  dead line pickup 6-22  
  directional element 6-36  
  external inputs 6-3  
  output relay contacts 6-3  
  weak infeed 6-20  
testing procedures 6-1  
time 3-14

## U

utilities 3-14

## V

version descriptions 2-vii  
view 3-15  
view logs 3-3  
view readings 3-3  
view settings 5-23  
virtual inputs 3-12, 3-14, 5-10, L-11

## W

weak infeed 4-18  
weak infeed logic 4-44