

USE AND MAINTENANCE MANUAL

SILENT ELECTRIC ROTARY SCREW COMPRESSORS

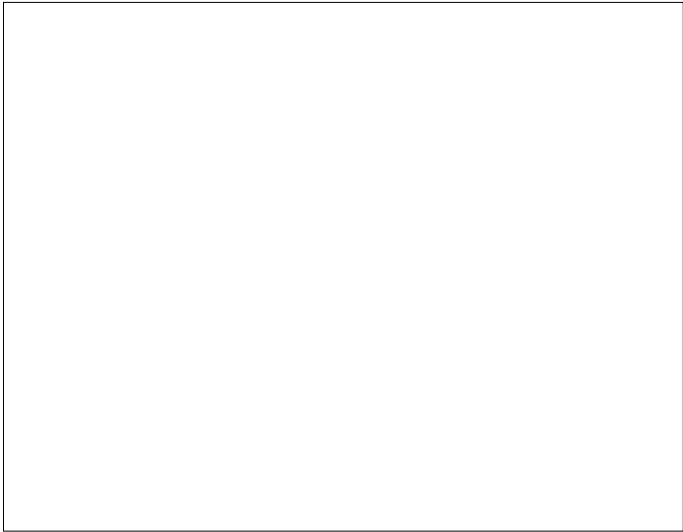

WARNING: Read this manual carefully and in full before using the compressor.

IMPORTANT INFORMATION

Read all the operational instructions, safety recommendations and all warnings provided in the instruction manual. Most accidents encountered when using the compressor are merely due to the failed observance of basic safety standards.

Accidents are prevented by foreseeing potentially hazardous situations and observing the appropriate safety standards.

The fundamental safety standards are listed in the "SAFETY" section of this manual and also in the section involving the use and maintenance of the compressor.

Hazardous situations to be avoided in order to prevent serious personal injuries and machine damages are listed in the "WARNINGS" section of the instruction manual or are actually printed on the machine.

Never use the compressor improperly but only as recommended by the **Manufacturer**.

The **Manufacturer** reserves the right to up-date the technical information given in this manual without notice.

I Index

0	Foreword	5
0.1	How to read and use the instruction manual	5
0.1.a	Importance of the manual	5
0.1.b	Conserving the manual	5
0.1.c	Consulting the manual	5
0.1.d	Symbols used	6
1	General information	7
1.1	Identification data of the manufacturer and the compressor	7
1.2	Information on machine technical/maintenance service	7
1.3	General safety warnings	7
2	Preliminary machine information	10
2.1	General description	10
2.2	Intended use	10
2.3	Technical data	11
3	Transport, Handling, Storage	12
3.1	Transporting and handling the packed machine	12
3.2	Packing and unpacking	12
3.3	Storing the packed and unpacked compressor	13
4	Installation	14
4.1	Admitted surrounding conditions	14
4.2	Space required for maintenance	14
4.3	Positioning the compressor	15
4.4	Connecting the compressor to the sources of energy and relative inspections	16
4.4.1	Connecting the compressor to the electrical mains power supply	16
4.4.2	Connecting to the pneumatic mains (compressor a on the ground)	19
5	Using the compressor	20
5.1	Preparing to use the compressor	20
5.1.1	Operational principle	20
5.1.2	Tank	20
5.2	Controls, indicators and safety devices of the compressor	21
5.2.1	Control panel	21
5.2.2	Display	22
5.2.3	Auxiliary control devices	25
5.3	Check the efficiency of the safety devices before starting	25

5.4	Starting the compressor	25
5.5	Stopping the compressor	26
6	Compressor maintenance.....	27
6.1	Instructions relative to inspections and maintenance jobs.	27
6.1.1	Changing the oil	30
6.1.2	Replacing the oil filter cartridge.....	31
6.1.3	Replacing the filter cartridge of the oil separator	31
6.1.4	Replacing the air filter cartridge	32
6.1.5	Tightening the belt	32
6.1.6	Replacing the belt	32
6.1.7	Cleaning the air/oli radiator	33
6.1.8	Cleaning the dust-removal pre-filter	33
6.1.9	Lubricating the electric motor	33
6.1.10	Draining the condensate	34
6.2	Diagnosing the alarm status/inconveniences-faults	34
7	Drawings and diagrams	37
7.1	Wiring diagrams	37
7.2	Pneumatic diagrams	40

Maintenance schedule

0 Foreword

0.1 How to read and use the instruction manual

0.1.a Importance of the manual

This **INSTRUCTION MANUAL** has been written to guide you through the **INSTALLATION, USE** and **MAINTENANCE** of the compressor purchased.

We recommend that you strictly observe all the indications given within as the ideal operational efficiency and lasting wear of the compressor depend on the correct use and methodical application of the maintenance instructions given hereafter.

Remember that when any doubts or inconveniences arise it is a good rule to always contact the **AUTHORISED SERVICE CENTRES**. They are at your complete disposal for any explanations or jobs required.

The **Manufacturer** therefore declines all liabilities regarding the incorrect use and poor maintenance of the compressor.

The **INSTRUCTION MANUAL** is integral part of the compressor.

Ensure that any up-dates forwarded by the **Manufacturer** are actually added to the manual.

If the compressor is sold on at a later date the manual must be given to the new owner.

0.1.b Conserving the manual

Use and read the manual with care being careful not to damage any part of it.

Do not remove, tear or re-write any parts of the manual for any reason whatsoever.

Keep the manual in a dry and sheltered place.

0.1.c Consulting the manual

This instruction manual is made up of the following:

- **FRONT COVER WITH MACHINE IDENTIFICATION**
- **DETAILED INDEX**
- **INSTRUCTIONS AND/OR NOTES ON THE COMPRESSOR**

The model and serial number of the compressor to which the manual refers and that you have purchased is found on the **FRONT COVER**.

The various **SECTIONS** in which all the notes relative to a certain subject are found in the **INDEX**.

All the **INSTRUCTIONS AND/OR NOTES ON THE COMPRESSOR** aim at pointing out safety warnings and procedures required to use the compressor correctly.

0.1.d Symbols used

The **SYMBOLS** pointed out below are used throughout this manual and their purpose is that of drawing the operator's attention, informing the latter how to behave and how to proceed in each operational situation.



READ THE INSTRUCTION MANUAL

Read the use and maintenance manual carefully before installing and starting the compressor.



GENERAL HAZARDOUS SITUATION

An additional note will point out the type of hazard involved.
Meaning of the indications:

Warning!

This points out a potentially hazardous situation, which if ignored, could cause personal injury and machine damage.

Note!

This enhances crucial information.



RISK OF ELECTRIC SHOCK

Warning: the electrical power supply of the compressor must be disconnected before doing any jobs on the compressor.



RISK OF SCOLDING

Warning: be careful when touching the compressor as some parts of it could be very hot.

1 General information

1.1 Identification data of the manufacturer and the compressor

COMPRESSOR IDENTIFICATION NAMEPLATE (Example)

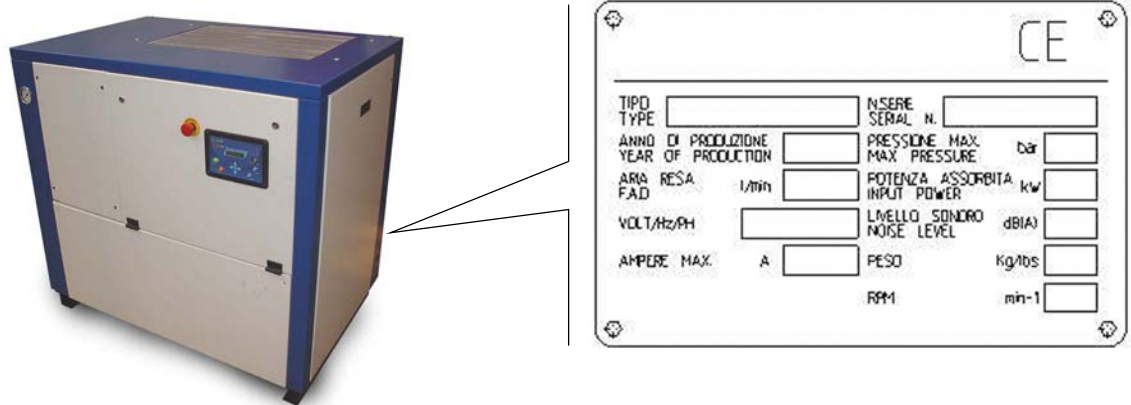

Silent electric rotary screw compressor.

1.2 Information on machine technical/maintenance service

We remind you that our technical service department is at your complete disposal to help you resolve any problems that may possibly be encountered, or to provide you with any other information necessary.

In the case of need contact:

Our **CUSTOMER TECHNICAL SERVICE** department or your local dealer.

The constant and efficient performance of the compressor is ensured only if original spare parts are used.

We recommend therefore that you strictly observe the indications provided in the MAINTENANCE section and to use **EXCLUSIVELY** original spare parts.

The use of NON ORIGINAL spare parts automatically annuls the guarantee.

1.3 General safety warnings

Note! The procedures provided in this manual have been written to assist the operator throughout the use and maintenance of the compressor.



IMPORTANT INSTRUCTIONS FOR THE SAFE USE OF THE COMPRESSOR

WARNING: THE INAPPROPRIATE USE AND POOR MAINTENANCE OF THIS COMPRESSOR MAY CAUSE PHYSICAL INJURY TO THE USER. YOU ARE RECOMMENDED TO CAREFULLY FOLLOW THE INSTRUCTIONS PROVIDED HEREAFTER TO AVOID SUCH RISKS.

1. DO NOT TOUCH MOVING PARTS

Never put your hands, fingers or other parts of the body near moving parts of the compressor.

2. NEVER USE THE COMPRESSOR WITHOUT THE SAFETY GUARDS FITTED

Never use the compressor without all the safety guards fitted perfectly in their correct place (i.e. panelling, belt guard, safety valve). If these parts are to be removed for maintenance or servicing purposes, ensure that they are put back in their original place perfectly before using the compressor again.

3. ALWAYS WEAR SAFETY GOGGLES

Always wear goggles or equivalent eye protection means. Never direct compressed air towards any part of your body or that of others.

4. PROTECT YOURSELF AGAINST ELECTRIC SHOCKS

Avoid accidentally touching the metal parts of the compressor with your body, such as pipes, the tank or metal parts connected to earth. Never use the compressor where there is water or in damp rooms.

5. DISCONNECT THE COMPRESSOR

Disconnect the compressor from the electric power supply and completely discharge the pressure from the tank before carrying out any service, inspection, maintenance, cleaning, replacing or inspection jobs of each part.

6. ACCIDENTAL START-UP

Never move the compressor while it is connected to the electrical power supply or when the tank is pressurised. Ensure that the main switch is turned OFF before connecting the compressor to the electrical power supply.

7. STORE THE COMPRESSOR APPROPRIATELY

When the compressor is not in use, it must be stored in a dry room away from atmospheric agents. Keep it out of children's reach.

8. OPERATIONAL AREA

Keep the work area clean and remove any tools that are not required. Keep the work area sufficiently ventilated. Never use the compressor in the presence of flammable liquids or gas. The compressor may produce sparks while running. Do not use the compressor where there may be paints, gasoline, chemical compounds, glues and any other flammable or explosive material.

9. KEEP THE COMPRESSOR OUT OF CHILDREN'S REACH

Prevent children or anyone else from touching the power supply cable of the compressor. All outsiders must be kept at a safe distance from the operational area.

10. WORK CLOTHES

Do not wear unsuitable clothing, ties or jewellery as these may get caught up in moving parts. Wear caps to cover your hair if necessary.

11. PRECAUTIONS FOR THE POWER SUPPLY CABLE

Do not disconnect the power supply plug by pulling on the cable. Keep the cable away from heat, oil and sharp edges. Do not stand on the electrical cable or squash it under heavy weights.

12. LOOK AFTER THE COMPRESSOR WITH CARE

Follow the maintenance instructions. Inspect the power supply cable on a periodic basis and if damaged it must be repaired or replaced by an authorised service centre. Visually check the outside appearance of the compressor, ensuring that there are no visual anomalies. Contact your nearest service centre if necessary.

13. ELECTRICAL EXTENSIONS FOR OUTDOOR USE

When the compressor is used outdoors, use only electrical extensions manufactured for outdoor use and marked as such.

14. WARNING

Pay attention to everything you do. Use your common sense.

Do not use the compressor if you are tired. The compressor must never be used if you are under the effect of alcohol, drugs or medicines, which could make you tired.

15. CHECK FAULTY PARTS OR AIR LEAKS

Before using the compressor again, if a safety guard or other parts are damaged, they must be checked carefully to evaluate whether they may operate as established in complete safety. Check the alignment of moving parts, hoses, gauges, pressure reducers, pneumatic connections and every other part that may be crucial for the normal operational efficiency of the compressor. All damaged parts must be properly repaired or replaced by an authorised service centre or replaced following the instructions provided in instruction manual.

16. USE THE COMPRESSOR EXCLUSIVELY FOR THE APPLICATIONS SPECIFIED IN THIS INSTRUCTION MANUAL.

The compressor is a machine that produces compressed air.

Never use the compressor for purposes other than those specified in the instruction manual.

17. USE THE COMPRESSOR CORRECTLY

Operate the compressor in compliance with the instructions provided in this manual. Do not allow children to use the compressor or those who are not familiar with it.

18. ENSURE THAT EACH SCREW, BOLT AND GUARD IS FIRMLY SECURED IN PLACE.**19. KEEP THE IN-TAKE GRIDS CLEAN**

Keep the motor ventilation grids clean. Regularly clean these grids if the work area is particularly dirty.

20. OPERATE THE COMPRESSOR AT THE RATED VOLTAGE

Operate the compressor at the voltage specified on the electric data plate. You could damage or burn-out the motor and other electric components if the compressor is operated at a higher or lower voltage than its rated voltage.

21. NEVER USE THE COMPRESSOR IF IT IS FAULTY

If the compressor is noisy or vibrates excessively when running or it seems to be faulty, stop it immediately and check its efficiency or contact your nearest authorised service centre.

22. DO NOT CLEAN PLASTIC PARTS USING SOLVENTS

Solvents such as gasoline, thinners, gas oil or other compounds that contain hydrocarbons may damage the plastic parts. Clean them with a soft cloth and soapy water or other suitable liquids.

23. USE ORIGINAL SPARE PARTS ONLY

The use of non-original spare parts involves the annulment of the guarantee and the abnormal running conditions of the compressor. Original spare parts are available c/o the authorised dealers.

24. DO NOT MODIFY THE COMPRESSOR

Do not modify the compressor. Contact an authorised service centre for all repairs required. An unauthorised modification may impair the efficiency of the compressor and may also cause serious accidents for those who do not have the technical skill required to make such modifications.

25. TURN THE COMPRESSOR OFF WHEN IT IS NOT IN USE

When the compressor is not in use turn the main ON/OFF switch OFF (position "0").

26. DO NOT TOUCH HOT PARTS OF THE COMPRESSOR

To avoid scolding do not touch pipes, the motor or any other hot part.

27. DO NOT DIRECT THE JET OF AIR DIRECTLY TOWARDS THE BODY

To avoid all risks never direct the jet of air towards people or animals.

28. DO NOT STOP THE COMPRESSOR BY PULLING ON THE POWER SUPPLY CABLE

Use the "O/I" (ON/OFF) buttons of the control panel to stop the compressor.

29. PNEUMATIC CIRCUIT

Use recommended pneumatic hoses and tools that can withstand the same or a higher pressure than the maximum running pressure of the compressor.

30. SPARE PARTS

Use only original and identical spare parts to replace worn or damaged ones.

Repairs must be made exclusively by authorised service centres.

31. CORRECT USE OF THE COMPRESSOR

The operator must be perfectly familiar with all the controls and compressor characteristics before starting to work with the machine.

32. MAINTENANCE JOBS

The use and maintenance jobs of the commercial components fitted on the machine, but not indicated in this manual, are indicated in the enclosed documents.

33. DO NOT UNSCREW THE CONNECTION WHEN THE TANK IS PRESSURISED

Do not unscrew the connection for any reason whatsoever with the tank pressurised without first checking if the tank is discharged.

34. DO NOT MODIFY THE TANK

It is prohibited to intentionally drill, weld or deform the compressed air tank.

35. IF THE COMPRESSOR IS USED FOR PAINTING JOBS

- a) Do not work in closed rooms or near free flames.
- b) Ensure that the room in which you are working is sufficiently ventilated.
- c) Wear face and nose mask.

36. DO NOT PUT OBJECTS OR PARTS OF THE BODY IN THE PROTECTION GRIDS

Do not put objects or parts of the body in the protection grids to prevent physical injuries and damage to the compressor.



KEEP THESE USE AND MAINTENANCE INSTRUCTIONS CAREFULLY AND GIVE THEM TO PERSONNEL WISHING TO USE THE COMPRESSOR!

WE RESERVE THE RIGHT TO MAKE MODIFICATIONS WHERE NECESSARY WITHOUT NOTICE

2 Preliminary machine information

2.1 General description

The **rotary screw compressor** has been specifically designed aiming at minimising maintenance and labour costs.

The outside cabinet is completely covered in sound-proof and oil-proof panelling thus ensuring its extended and lasting wear.

The components have been arranged so that all vital parts can be easily reached for maintenance purposes simply by opening dedicated panels with quick-release locking devices.

The filters and adjustment and safety devices (oil filter, air filter, oil separator filter, regulator valve, minimum pressure valve, max. pressure safety valve, thermostat, belt tightener, screw compression unit, pressure switch and oil separator tank emptying and filling taps) are all fitted on the same side.

The dryer series has been devised with the intention of enclosing a complete compressed air system in one compact machine. It is indeed connected to a dryer that is capable of supplying dry air to ensure the perfect and lasting use of the tools.

Note! **The tanks of the compressors have been manufactured in compliance with the EEC/404/87 Directive for the European market.**
The compressors have been manufactured in compliance with the EC/37/98 Directive for the European market.

Note! **Check your model on the identification nameplate fitted on the compressor. It is also indicated in this manual.**

ADVISED LUBRICANTS

Always use oil for turbines with approximately 46 cSt at 40°C and a pour point of at least -8 +10°C. The flash point must be greater than +200°C.



NEVER MIX DIFFERENT OIL QUALITIES.

SCREW OIL

ESSO	EXXCOLUB 46
BP	ENERGOL HLP 46
SHELL	CORENA D 46
TOTAL	AZOLLA ZS 46
MOBIL	DTE OIL 25
DUCKHAMS	ZIRCON 46

Use oil with VG32 rating for cold climates and VG68 for tropical climates.

It is advisable to use synthetic oils for very hot and humid climates.

2.2 Intended use

The silent rotary screw compressors have been designed and manufactured exclusively to produce compressed air. **EVERY OTHER USE, DIFFERENT AND NOT FORESEEN BY ALL INDICATED, RELIEVES THE MANUFACTURER OF POSSIBLE CONSEQUENT RISKS.**

In any event the use of the compressor different to that agreed in the purchase order **RELIEVES THE MANUFACTURER FROM ALL LIABILITIES WITH REGARD TO POSSIBLE MATERIAL DAMAGE AND PERSONAL INJURY.**

The electrical system is not designed for the use in environments subject to explosion or for flammable products.



NEVER DIRECT THE JET OF AIR TOWARDS PEOPLE OR ANIMALS. NEVER USE THE COMPRESSED AIR PRODUCED BY LUBRICATED COMPRESSORS FOR RESPIRATORY PURPOSES OR IN PRODUCTION PROCESSES WHERE THE AIR IS IN DIRECT CONTACT WITH FOODSTUFFS UNLESS IT HAS BEEN FIRST FILTERED

2.3 Technical data

Model	HP25		HP30		HP40					
	8-116	10-145	13-188	8-116	10-145	13-188				
Max. pressure	bar/psi	3050	2710	2240	3540	3190	2720	3980	3720	3200
Type of rotary screw end		NK100	NK100	NK100	NK100	NK100	NK100	NK100	NK100	NK100
Free air delivery ISO 1217	l/min	108	96	79	125	113	96	140,4	131,3	113
Air outlet fitting	R	1" G	1" G	1" G	1" G	1" G	1" G	1" G	1" G	1" G
Lubricant qty	l	6,5	6,5	6,5	6,5	6,5	6,5	6,5	6,5	6,5
Fan capacity	m ³ /h	<3	<3	<3	<3	<3	<3	<3	<3	<3
Oil residue in air	ppm	MEC160	MEC160	MEC160	MEC160	MEC160	MEC160	MEC180	MEC180	MEC180
2-pole electric motor	IEC	25/18,5	25/18,5	25/18,5	30/22	30/22	30/22	40/30	40/30	40/30
Output	HP/KW	55	55	55	55	55	55	55	55	55
Protection rating	IP	S 1	S 1	S 1	S 1	S 1	S 1	S 1	S 1	S 1
Service	N°	10	10	10	10	10	10	10	10	10
Max. starts per hour		5/45	5/45	5/45	5/45	5/45	5/45	5/45	5/45	5/45
Ambient temperature limits	°C (min/max)	69	69	69	70	70	70	72	72	72
Noise level	dB(A)									

Sound level measured in a free range at a distance of 4 m: ±3 dB(A) at the maximum working pressure.

Note! The technical data and dimensions of the machine are subject to variations at any time without notice

AND CONDITIONED FOR SUCH PURPOSE.

3 Transport, Handling, Storage



In order to use the compressor in complete safety read the safety standards given in section 1.3. before reading this section.

3.1 Transporting and handling the packed machine



The packed compressor must be transported by qualified personnel using a forklift truck.

Before moving the machine ensure that the load-bearing capacity of the forklift truck is sufficient to take the weight to be lifted.

Position the forks exclusively as illustrated below. Once the forks have been positioned in the points indicated, lift slowly without jerking.



Never stand near the area where the compressor is being handled and never stand on the crate while it is being moved.

3.2 Packing and unpacking

To avoid damages and to protect the compressor during transport it is usually placed on a wooden pallet, to which it is secured by screws and covered with cardboard.

All the shipping and handling information and symbols are printed on the compressor packing. Upon consignment remove the top part of the packing and check if any damages have been encountered during transport. If any damages are found, caused during transport, immediately make a written claim, backed up with photos of the damaged parts if possible and forward everything to your insurance company, with copy to the **Manufacturer** and transporter.

Using a forklift truck take the compressor as near as possible to the place where it is to be installed then carefully remove the protective packing without damaging it, following the instructions below:

- Remove the packing **1**, by sliding it away upwards.



- Unscrew screws **2** that block the feet that secure the compressor to the pallet (only for models with tank).



Note! The compressor can be left on the packing pallet to make it easier to move.

Carefully ensure that the contents correspond with all written in the consignment documents. Dispose of the packing in compliance with current standards in force in the country of installation.

Note! The machine must be unpacked by qualified personnel using appropriate tools and equipment.

3.3 Storing the packed and unpacked compressor

For the whole time that the compressor is not used before unpacking it, store it in a dry place at a temperature between +5°C and + 45°C and sheltered away from weather.

For the whole time that the compressor is not used after unpacking it, while waiting to start it up or due to production stoppages, place sheets over it to protect it from dust, which may settle on the components. The oil is to be replaced and the operational efficiency of the compressor is to be checked if it is not used for long periods.

4 Installation



In order to use the compressor in complete safety read the safety standards given in section 1.3. before reading this section.

4.1 Admitted surrounding conditions

Position the machine as established when the order was placed. Failing this the **Manufacturer** is not liable for any inconveniences that may possibly arise.

Unless pointed out otherwise when placing the order, the compressor must work regularly in the surrounding conditions indicated below:

ROOM TEMPERATURE

The room temperature must not be lower than 5°C or higher than 45°C to ensure the ideal operational efficiency of the compressor.

If the compressor works at a room temperature lower than the minimum value, the condensate could be separated within the circuit and therefore the water would mix with the oil, thus deteriorating the quality of the latter, failing to guarantee the even formation of the lubricating film between the moving parts with the possibility of seizure.

If the compressor works at a room temperature higher than maximum value, the compressor would take in air that is too hot, which would prevent the heat exchanger from adequately cooling the oil in the circuit, raising the working temperature of the machine, thus causing the thermal safety device to trip, which stops the compressor due to an excessive temperature of the air/oil mixture at the screw outlet.

The maximum temperature of the room is to be measured while the compressor is running.

LIGHTING

The compressor has been designed in compliance with legal prescriptions and in the attempt to minimise shadow zones to facilitate the operator's job.

The lighting system of the factory is to be considered as crucial for the operator's safety.

The room in which the compressor is installed must have no shadow zones, dazzling lights or stroboscopic effects due to the lighting.

ATMOSPHERE WITH RISK OF EXPLOSION AND/OR FIRE

The standard compressor is not pre-arranged or designed to work in rooms subject to the risk of explosion or fire. The performance of the compressor may decrease at the maximum permitted ambient temperature, with relative humidity higher than 80% and at an altitude of more than 1,000 mt.

4.2 Space required for maintenance

The compressor must be installed in a large room that is well-aired, dust-free and sheltered away from rain and frost. The compressor takes in a large amount of air that is required to ventilate it internally. A dusty atmosphere would in time cause damages and inefficient performance.

Part of the dust once inside is taken in by the air filter causing it to clog rapidly and another part of dust will settle on the components and will be blown against the cooling radiator, consequently compromising the efficiency of the heat exchanger. It is therefore obvious that the cleanliness of the area in which the compressor is installed is crucial for the correct efficiency of the machine, avoiding excessive running and maintenance costs. To facilitate maintenance jobs and to create a favourable circulation of air, the compressor must have a sufficient free space all around it (see fig.).

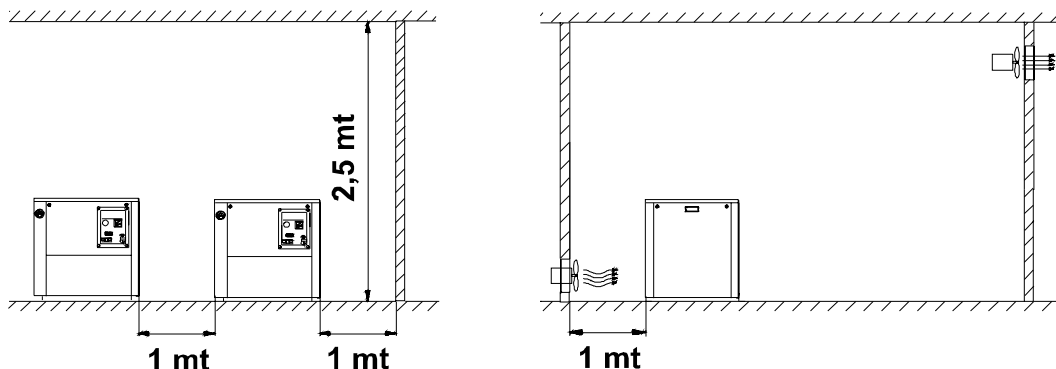

The room must be provided with outlets that lead outdoors near the floor and ceiling that will allow the natural circulation of air. If this is not possible, install some fans or extractors that guarantee a higher air flow rate than that taken in by the compressor.

Ducts for the inlet and outlet of the air can be used in unfavourable environments. These ducts must be the same size as the in-take and delivery grid. If these ducts are longer than 3 meters contact the **Authorised Service Centre**.

Note! A conveyance system can be fitted to recover the hot ventilation air delivered, which can be used to heat the room or for other purposes. It is crucial that the cross section of the system that recovers the hot air is greater than the total cross section of the grid slots plus the system must be equipped with a forced extraction system (extractor fan) to favour a constant downflow.

4.3 Positioning the compressor

Once the position in which the compressor is to be installed has been identified ensure that the compressor is set on a flat surface.

The dryer versions are already internally pre-arranged with all pneumatic connections between compressor, tank and dryer.

No special foundations or bases are required for the machine.

Lift the compressor using a forklift truck (forks at least 900 mm long) and fit the vibration-damping feet **1** and block with the nuts **2** under the four resting points where established. Anti-vibration feet are fitted on the floor-based version as standard. They can be fitted on the tank on request.

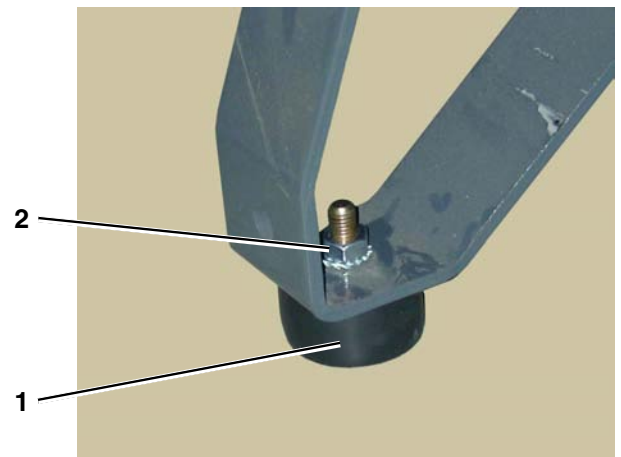
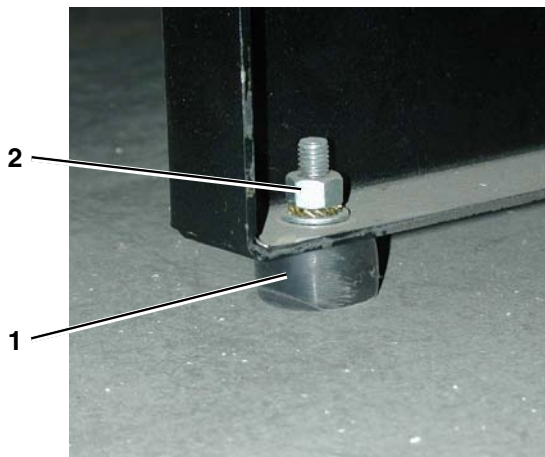

Do not secure the compressor rigidly to the floor.

4.4 Connecting the compressor to the sources of energy and relative inspections.

4.4.1 Connecting the compressor to the electrical mains power supply



The compressor is to be connected to the electrical mains by the customer, to his exclusive liability, employing specialised personnel and in compliance with the Accident Prevention Norms EN 60204.

INSTRUCTIONS FOR CONNECTING TO EARTH

This compressor must be connected to earth while in use in order to safeguard the operator against electrical shocks. The electrical connection must be carried out by a skilled engineer. It is advisable never to dismantle the compressor or even to make any other connections. All repairs must be carried out exclusively by authorised service centres or other qualified centres. The earth wire of the power supply cable of the compressor must be connected only and exclusively to the **PE** pin of the terminal board of the actual compressor. Before replacing the plug of the power supply cable ensure that the earth wire is connected.

EXTENSION CABLE

Use only extension cables with plug and earth connection. Never use damaged or squashed extension cables. Ensure that the extension cable is in a good state of wear. When using an extension cable, ensure that the cross section of the cable is sufficient to convey the current absorbed by the product to be connected. If the extension cable is too thin there could be drops in voltage and therefore loss in power and overheating of the equipment.

The extension cable of the three-phase compressors must have a cross section in proportion with its length: see table below:

CORRECT CROSS SECTION FOR THE MAXIMIM LENGTH OF 20M

HP	kW	220/240V 50/60 Hz 3 ph	380/415V 50/60 Hz 3 ph
25	18,5	35 mm ²	16 mm ²
30	22	50 mm ²	25 mm ²
40	30	70 mm ²	25 mm ²



Avoid all risks of electrical shocks. Never use the compressor with damaged electrical cables or extension cables. Regularly check the electrical cables. Never use the compressor in or near water or near a hazardous area where electrical shocks may be encountered

ELECTRICAL CONNECTION

The **three-phase compressors (L1+L2+L3+PE)** must be installed by a qualified engineer. The three-phase compressors are supplied without plug and cable.

The power supply cable must be fed into the electrical cabinet through the dedicated cable clamps **1** situated on the RH side and on the electrical cabinet of the compressor.

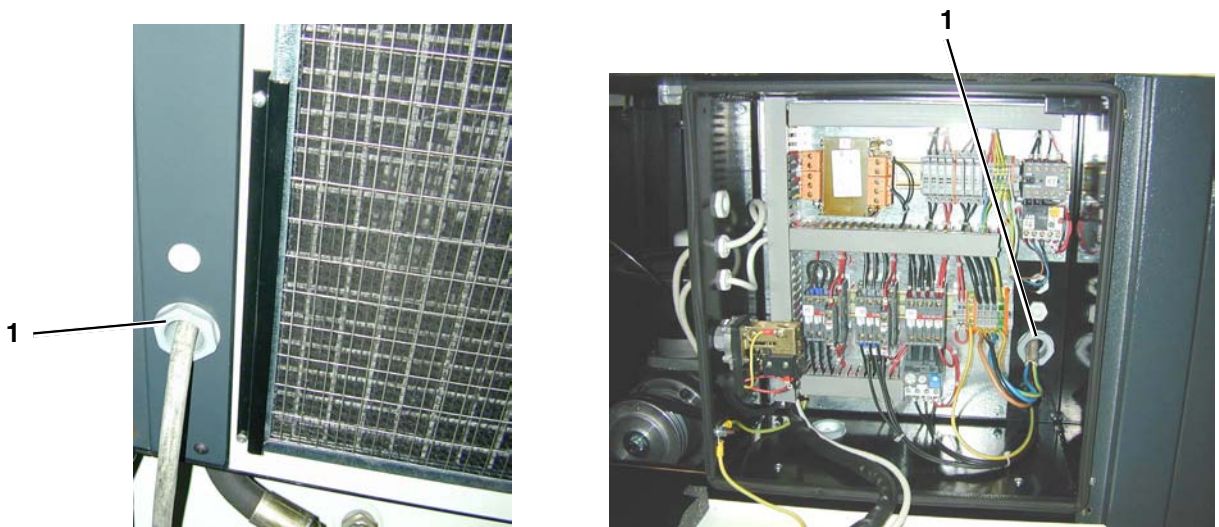

Ensure that the cable cannot accidentally come into contact with moving or hot components, possibly secure with clips.

The cross section of the wires of the power supply cable (for lengths of 4 m and ambient temperatures of 50°C at the most) must be as follows:

Power Hp	Rated voltage 380/415V	Rated voltage 220/240V
25	10 mm ²	25 mm ²
30	16 mm ²	35 mm ²
40	16 mm ²	35 mm ²

It is advisable to install the connector, magneto thermal switch and fuses near the compressor (3 m away at the most). The magneto thermal switch and the fuses must have the characteristics indicated in the table below:

Power Hp	Rated voltage 380/415V		Rated voltage 220/240V	
	Magneto thermal switch	Fuse	Magneto thermal switch	Fuse
25	63 A	63 A	80 A	100 A
30	80 A	80 A	125 A	125 A
40	100 A	100 A	160 A	160 A

Note! The fuse parameters indicated in the table above refer to the **gI** type (**standard**). If cartridge fuses type **aM** are used (**delayed**) the parameters in the table are to be reduced by 20%. The parameters of the magneto thermal switches refer to switches type **K**.

Ensure that the installed power in kW is at least double the input of the electric motor. All **silent rotary screw compressors** avail of Star/Delta starting, which enables the motor to start with as little electrical energy consumption upon start-up as possible.

The mains voltage must correspond with that indicated on the electrical data nameplate of the machine; the admitted tolerance must remain within +/- 6%.

EXAMPLE:

Voltage, 400 Volt: minimum tolerance 376 Volt

Voltage, 400 Volt: maximum tolerance 424 Volt

The plug of the power supply cable must never be used as a switch but must be plugged into a power socket that is controlled by an adequate differential switch (magneto thermal switch).



Never use the earth connection instead of the neutral. The earth connection must be achieved according to the EN 60204 industrial safety standards. Ensure that the mains voltage corresponds with that required for the correct operation of the compressor.

CHECK THE ROTATION DIRECTION

When connecting the compressor to the electrical mains for the first time ensure that the STOP ALARM is not triggered, which is pointed out by the red LED lit steady, by a buzzer and by a warning on the display 1 stating: **ROTATION ALARM**.

This alarm points out the incorrect connection order of the electrical power supply cables (relative to the three phases) that causes the incorrect rotation direction of the screw unit. Once the cable connection has been rectified press the RESET key 3.

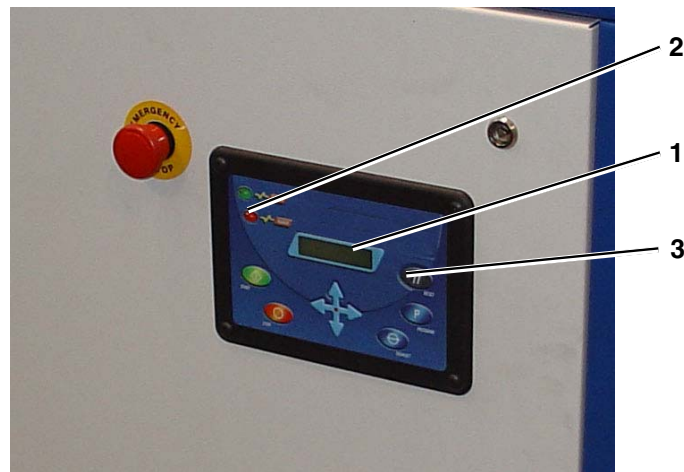

Warning!

The incorrect rotation direction for more than 20 seconds will irreparably damage the compressor.

4.4.2 Connecting to the pneumatic mains (compressor a on the ground)



**Always use pneumatic hoses for compressed air with the maximum pressure characteristics and cross section suitable for those of the compressor.
Do not try to repair a faulty hose.**

Connect the compressor to the pneumatic mains using the fitting **1** pre-arranged on the compressor. Use hosing with a greater or same diameter as the compressor outlet.

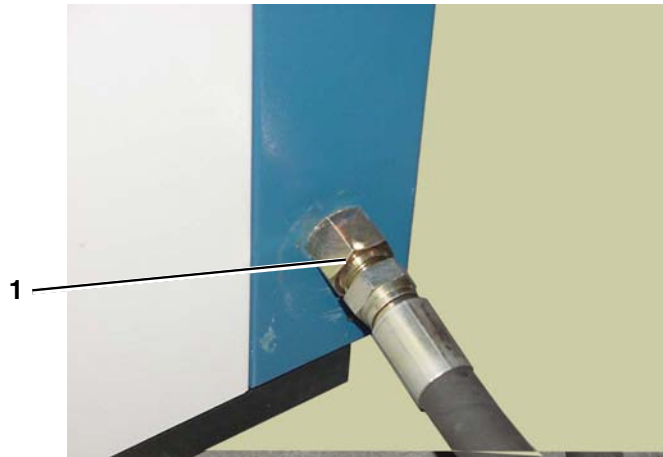

Install two ball taps with capacity suitable for the compressor between the compressor and tank and between the tank and line.

Do not install non-return valves between compressor and tank. The non-return valve is already installed inside the compressor.

5 Using the compressor



In order to use the compressor in complete safety read the safety standards given in section 1.3. before reading this section.

5.1 Preparing to use the compressor

5.1.1 Operational principle

The air taken-in by the filter passes through a valve that controls its flow rate to the screw where, mixing with the oil, it is compressed.

The air/oil mix produced by compression reaches a tank where the initial separation by gravity is achieved; as the oil is heavier, it settles on the bottom, it is then cooled and sent through a heat exchanger, filtered and injected into the screw again.

The oil is required to reduce the heat produced by compression, to lubricate the bearings and to maintain the coupling of the screw lobes. The air is sent through an oil separator filter to be additionally purified from residue oil particles. It is cooled by means of another heat exchanger and is finally outlet to be used at low temperature and with acceptable oil residues (<3p.p.m.). A safety system controls the crucial points of the machine and points out any abnormal conditions. The temperature of the air/oil mix at the screw outlet is controlled by a thermostatic probe, which stops the compressor if the temperature is too high (105°C). A thermal protection device is fitted on the electric motor, which stops the machine if necessary.

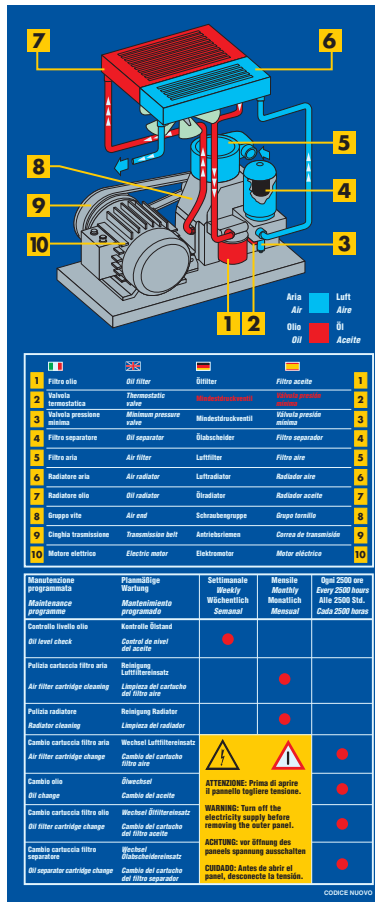

5.1.2 Tank

The tank is used to store and ensure further stability of the air pressure.

The capacity of the tank must be established in relation to the utility.

The features of the tank must strictly comply with the requirements established by current standards in the country of installation.

Carefully ensure that the safety devices of the tank are enabled and efficient.

5.2 Controls, indicators and safety devices of the compressor

5.2.1 Control panel

The control panel is made up of a set of buttons required for the main operational and control functions of the compressor.

1 START (I)

This button is used to turn the compressor on.

If there is a power shortage the compressor stops. This button is to be pressed to start it again.

2 STOP (0)

Press this button to stop the compressor within a few seconds. It is better to stop the compressor using this button, as the whole pneumatic circuit within the compressor drops to 0 bar.

3 RED LED

This points out that an alarm has triggered and the compressor stops, or it points out that the compressor needs to be serviced, in which case the compressor will continue to run regularly.

4 DISPLAY

The instrument shows the delivery temperature of the air-oil mix: the compressor stops when the air-oil mix reaches 105°C, in which case LED 3 lights up.

5 GREEN LED

This points out that the compressor is powered.

6 RESET

This button is used to reset an alarm.

7 PROGRAM

This button is used to activate the programming function.

8 EMERGENCY PUSH BUTTON

This mechanically blocking push button is used to immediately stop the compressor in the case of emergency. With the push button blocked it is impossible to start the compressor.

To start the compressor again, turn the emergency button to release it, then press button **RESET 6** and button **START(I)**.

9 TASTI FRECCIA

These are used to move around within the menus.

10 DEFAULT

This is used to exit programming and to save the settings.

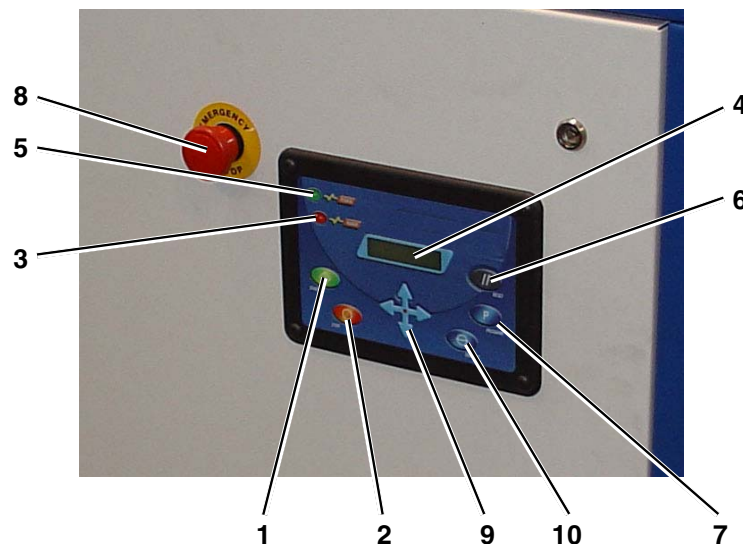

5.2.2 Display

CHECK THE SETTINGS

You can check the general settings of the control unit on the display by pressing the “Up arrow” or “Down arrow” key on the push button control panel:

Note! Refer to the descriptions of the menus to find out exactly what the parameters listed below mean.

WEDNES. 01-09-04 10:07.23	STAR-DELTA TIME 5 sec.	AL.THERMIC FAN Nr.0
ROTATION AL. Nr.0	CRS REL 2.1 27 MAY 2004 (PROGRAM REL.)	TIME STAND-BY 15 sec.
OL:00724 MAINTE OC:00483 1607	ALARM TEMP. 105°C	AL. TEMPERATURE Nr.0
START_FOR_ACTIV. DATE (IF ENABLED)	SELECT LANGUAGE ENGLISH	AL.LOW TEMP. Nr.0
DATE DISABLED (IF DISABLED)	TEMPERAT. UNIT CELSIUS	AL.THERMIC COMP. Nr.0

To exit, press the **DEFAULT** key or wait a few seconds.

MENUS ACCESSIBLE TO CLIENTS

How to access: Press the **PROGRAM** key.

How to exit: Press the **DEFAULT** key.

To access, press the **PROGRAM** key to see the following sub-menus.

1. Setting of the time and date “CLOCK SET-UP”
2. Menu for setting the daily, weekly and monthly start and stop times “CLIENT SET-UP”.

Once you have gained access, scroll the sub-menus using the “Up” and “Down” arrow keys of the push button control panel; press the **DEFAULT** to exit.

1. “PROGRAM” CLOCK SET-UP

TIME
(hh:mm)

Press “PROGRAM” again to access the date.

DATE SETTING
(gg:mm:aa)

The example display illustrates that you need to indicate the present time and date.

Once you have gained access, scroll the sub-menus using the “Up” and “Down” arrow keys of the push button control panel; press the **DEFAULT** to exit.

1. "PROGRAM" CLIENT SET-UP; DAILY, WEEKLY AND MONTHLY START AND STOP SETTINGS

Enabled (YES): "1"
 Disabled (NO): "2"

If enabled, you can use this function to set two daily start and two stop times by entering the start time and the stop time where hh stands for hours and mm stands for minutes.

At the end of the week, you can set three inoperative periods where gg stands for days and mm stands for months.

To disable it:

- press "PROGRAM"
- type-in "2" using the "UP arrow" or "DOWN arrow" button.
- press "PROGRAM"

To enable it:

- press "PROGRAM"
- type-in "1" using the "UP arrow" or "DOWN arrow" button.
- press "PROGRAM"

To exit the menu, press the **DEFAULT** key.

Once you are back on "PRESS START TO START", press the **START** key to start programming the calendar.

Note! If an asterisk appears on the digital display while the compressor is running, it means that the calendar is activated.

Dater Menu		Key		Description
Mon	Start 1 Stop 1 Start 2 Stop 2	√ √ √ √	(hh:mm) (hh:mm) (hh:mm) (hh:mm)	The menu repeats itself; you can set two START and two STOP times per day by entering the start time and the stop time (where "hh" stands for hours and "mm" for minutes) ATTENTION: Do NOT set a start time that is later than the stop time: I.E.: START1 15.00 STOP 1 14.00 ON THE SAME DAY. THE COMPRESSOR WILL NOT START BUT WILL WAIT FOR THE NEXT STARTING TIME.
Tue	Start 1 Stop 1 Start 2 Stop 2	√ √ √ √	(hh:mm) (hh:mm) (hh:mm) (hh:mm)	
Wed		√		
Thu		√		
Fri		√		
Sat		√		
Sun		√		
No work	Start 1 Stop 1 Start 2 Stop 2 Start 3 Stop 3	√ √ √ √ √ √	(gg.mm) (gg.mm) (gg.mm) (gg.mm) (gg.mm) (gg.mm)	You can set 3 No work periods at the end of the week (where "dd" stands for days and "mm" for months)

STOP ALARMS

This type of alarm stops the compressor and is pointed out by the *fixed red LED* (ALARM on control panel) and by a flashing message on the display explaining the cause for the alarm.

1. The following may appear on the display:

ALARM
ROTATION

THE COMPRESSOR DOES NOT START!

This alarm means that the electrical power supply cables have been connected incorrectly (relative to the three phases). **When connected correctly, the screw unit and the fan motor will run in the correct direction.**

To reset the machine:

Once you have connected the cables correctly, press the “RESET” key on the control dashboard.

2. When the maximum oil-air limit is exceeded ($T > T_{alarm} = 105^{\circ}\text{C}/221^{\circ}\text{F}$), the following appears on the display:

TEMPERATURE ALARM

THE COMPRESSOR STOPS - NB: The fan of the oil-air radiator starts.

To reset the machine:

- once the temperature T has dropped by at least $10^{\circ}\text{C}/18^{\circ}\text{F}$ compared to the maximum temperature, press the RESET button;
- press the “RESET” button on the control panel so that the compressor is ready to start.

3. The following may appear on the display:

LOW TEMP.ALARM

THE COMPRESSOR FAILS TO START BECAUSE THE TEMPERATURE IS TOO LOW -6°C

To reset the machine:

If the temperature rises to -5°C press the “RESET” button on the control panel and inside the machine so that the compressor is ready to start.

4. When the trip switch of the electric motor of the compressor trips, the following appears on the display:

COMPRESSOR TRIP
SWITCH ALARM

THE COMPRESSOR STOPS!

To reset the machine:

- Wait for the motor to cool down
- Remove the cause that stopped the motor, press the reset key of the trip switch (F1) inside the electric cabinet and press the “RESET” button on the control panel. (Ver 25-30Hp)
- Wait the automatic reset of thermal protection and press RESET button on the board. (Ver. 40Hp)

5. The following may appear on the display:

FAN MOTOR
TEMP.ALARM

THE COMPRESSOR STOPS!

To reset the machine:

- If the motor cools down and after you have removed the cause that stopped the motor, press the reset key of the trip switch (F6) inside the electric cabinet and press the RESET key so that the compressor is ready to start.(Ver 25-30Hp)
- Wait the automatic reset of thermal protection and press RESET button on the board. (Ver. 40Hp)

5.2.3 Auxiliary control devices

- 1 AIR CIRCUIT PRESSURE CONTROL GAUGE**
 - 2 MOTOR THERMAL PROTECTION SWITCH RESET BUTTON**
- This is positioned inside the electrical cabinet.
- Press this button to reset the motor thermal protection switch.
- 3 FAN MOTOR TRIP SWITCH RESET BUTTON (JUST 15-20 HP)**

It is positioned in the electric cabinet and is pressed to reset the trip switch of the fan motor.



1

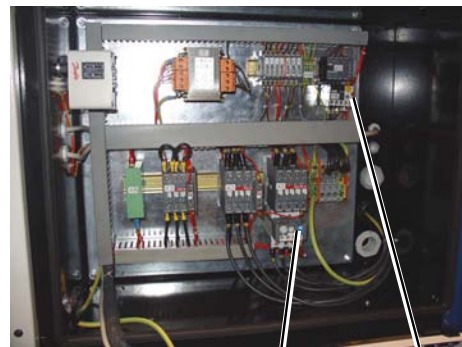

2

3

5.3 Check the efficiency of the safety devices before starting

OIL LEVEL

Check the oil level as indicated in **Section 6 “Compressor maintenance”**.



DO NOT START THE COMPRESSOR WITH THE GUARDS OPEN TO AVOID INJURY DUE TO MOVING COMPONENTS OR ELECTRICALLY POWERED EQUIPMENT.

5.4 Starting the compressor



Following an electrical shortage the compressor will start only if the START (I) button is pressed. Ventilation must occur as illustrated below.



It is of crucial importance that the compressor works with all the panels firmly closed. The failed observance of these and the following standards may lead to accidents that could cause personal injury and serious damages to the compressor or its equipment.

Before initially starting the compressor or following extended inoperative periods, start the machine intermittently by pressing the **START(I)-STOP(O)** buttons on and off for 3 or 4 seconds. After this it is advisable to run the compressor for a few minutes with the air outlet tap open. Then gradually shut-off the air tap and load to maximum pressure, checking if the inputs on each phase of the power supply are within the limits and also if the pressure switch trips. At this stage, check if the compressor runs idle for approximately 2 or 5 minutes, as it is the electronic board that chooses the idle running time according to the type of use. The pressure on the gauge on the panel must be between 1 and 2 bar. The compressor will stop at the end of this time. Discharge the air from the tank until the starting pressure is reached (2 bar difference compared to maximum pressure). Shut-off the air outlet tap and wait for the pressure switch to trip, which will shut-on the in-take valve and close the internal discharge. **For the correct operation of the models equipped with dryer, it is advisable to turn the dryer on 20 minutes before air is needed.**

CALIBRATION AND SETTINGS MADE BY THE MANUFACTURER

The **minimum pressure values** set are: 6, 8 and 11 for the 8, 10 and 13 bar models respectively.

Warning! **Disconnect the electrical power supply form the compressor before opening the electrical cabinet.**

The **thermal relay 2 F1** is set according to the table below:

Power Hp	Rated voltage 380/415V-3ph	Rated voltage 220/240V-3ph
25	22 A	38,1 A
30	25,7 A	44,3 A
40	/	/

Disconnect the electrical power supply form the compressor before opening the electrical cabinet. The setting of trip switch **2 must not** differ from the table given above; if the trip switch should trip, check the input of the fan motor, the voltage on the line terminals L1+L2+L3 during operation and the power connections inside the electric control panel and of the fan motor and FV fuses.

USEFUL TIPS FOR CORRECT COMPRESSOR PERFORMANCE

For the correct operational performance of the machine under full continuous load at the maximum working pressure, ensure that the temperature of the work area in a closed room does not exceed +40°C. It is advisable to use the compressor with a maximum service of 80% in one hour under full load in order to ensure the correct efficiency of the product in time.

The **thermal relay 3 F6** is set according to the table below:

Power HP	Rated voltage 380/415V-3ph	Rated voltage 220/240V-3ph
	50Hz	50Hz
25	0,49 A	0,85 A
35	0,51 A	1,0 A
40	/	/
	60Hz	60Hz
25	0,44 A	0,76 A
35	0,60 A	1,15 A
40	/	/

5.5 Stopping the compressor

Press the **STOP(O)** button to stop the compressor within a few seconds

Note! **By disconnecting the power supply from the external switch the compressor is completely without power.**

6 Compressor maintenance



In order to use the compressor in complete safety read the safety standards given in section 1.3. before reading this section.

6.1 Instructions relative to inspections and maintenance jobs.

The table that follows summarises the periodic and preventative maintenance jobs required to keep the compressor in an efficient operational state in time.

A brief description of the running hours after which the type of maintenance job is required.



Before performing any jobs within the sound-proof cabinet, ensure that:

- **The main line switch is turned off (position “0”)**
- **The compressor is disconnected from the compressed air system**
- **All the pressure has been released from the compressor and internal pneumatic circuit.**

The compressor has been especially designed to facilitate maintenance jobs by simply opening the side panel with quick-release locks.

Weekly: it is advisable to inspect the compressor, paying special attention to oil leaks and scale due to settled dust and oil.

Note! **If the compressor is used for more than 3000 hours/year the jobs indicated herewith are to be performed more often.**

Interval (hours)	Jobs to be performed	See section
500	Change the oil	6.1.1
	Replace the oil filter cartridge	6.1.2
	Tighten screws, cables, remote switches K1-K2-K3 and KV(just 15-20HP) ..	
	Tighten the belt	6.1.5
	Check hydraulic seals	
2500÷3000	Change the oil	6.1.1
	Replace the oil filter cartridge	6.1.2
	Replace the oil separator filter	6.1.3
	Replace the air filter	6.1.4
	Tighten screws, cables, remote switches K1-K2-K3 and KV(just 15-20HP) ..	
	Clean the air/oil radiator	6.1.8
	Clean the dust-removal pre-filter	6.1.9
	Draining the condensate	6.1.10
5000÷6000	Change the oil	6.1.1
	Replace the oil filter cartridge	6.1.2
	Replace the oil separator filter	6.1.3
	Replace the air filter	6.1.4
	Tighten screws, cables, remote switches K1-K2-K3 and KV(just 15-20HP) ..	
	Tighten the belt	6.1.5
	Check the hydraulic seals	
	Overhaul the in-take valve	
	Clean the air/oil radiator	6.1.7
	Clean the dust-removal pre-filter	6.1.8
	Test the motor thermal and fan (just 15-20HP) protection switch ..	
	Test the oil thermal protection switch	
8000÷9000	Change the oil	6.1.1
	Replace the oil filter	6.1.2
	Replace the oil separator filter	6.1.3
	Replace the air filter	6.1.4
	Tighten screws, cables, remote switches K1-K2-K3 and KV(just 15-20HP) ..	
	Replace the belt	6.1.6
	Check the hydraulic seals	
	Clean the air/oil radiator	6.1.7
	Clean the dust-removal pre-filter	6.1.8
11000÷12000	Change the oil	6.1.1
	Replace the oil filter	6.1.2
	Replace the oil separator filter	6.1.3
	Replace the air filter	6.1.4
	Tighten screws, cables, remote switches K1-K2-K3 and KV(just 15-20HP) ..	
	Tighten the belt	6.1.5
	Check the hydraulic seals	
	Check flexible hoses and replace if necessary	
	Overhaul the oil separator flange	
	Lubricate the minimum pressure valve	
	Overhaul the in-take valve	
	Clean the air/oil radiator	6.1.7
	Clean the dust-removal pre-filter	6.1.8
	Replace the Riisan hoses 6x4 and 8x10	
Replace screw oil guard		
Replace the motor bearings	6.1.9	

Interval (hours)	Jobs to be performed	See section
14000÷15000	Change the oil Replace the oil filter Replace the oil separator filter Replace the air filter Tighten screws, cables, remote switches K1-K2-K3 and KV(just 15-20HP) .. Check cables Tighten the belt Check the hydraulic seals Replace OR on delivery flange Tighten screws Check cooling fans Clean the air/oil radiator Clean the dust-removal pre-filter Clean the compressor Check the electric fan	6.1.1 6.1.2 6.1.3 6.1.4 6.1.5 6.1.7 6.1.8
17000÷18000	Change the oil Replace the oil filter Replace the oil separator filter Replace the air filter Tighten screws, cables, remote switches K1-K2-K3 and KV(just 15-20HP) .. Replace the belt Check the hydraulic seals Overhaul in-take valve Clean the air/oil radiator Clean the dust-removal pre-filter	6.1.1 6.1.2 6.1.3 6.1.4 6.1.6 6.1.7 6.1.8
20000÷21000	Change the oil Replace the oil filter Replace the oil separator filter Replace the air filter Tighten screws, cables, remote switches K1-K2-K3 and KV(just 15-20HP) .. Check the hydraulic seals Replace bearings and screw oil guard Replace the motor bearings Check or replace the thermostat valve of the screw unit	6.1.1 6.1.2 6.1.3 6.1.4 6.1.9
23000÷24000	Change the oil Replace the oil filter Replace the oil separator filter Replace the air filter Tighten screws, cables, remote switches K1-K2-K3 and KV(just 15-20HP) .. Tighten the belt Replace flexible hoses Clean air/oil radiator Check the electric fan and replace if necessary	6.1.1 6.1.2 6.1.3 6.1.4 6.1.5 6.1.7

The above described maintenance schedule has been planned bearing in mind all the installation parameters and recommended use of the **Manufacturer**.

The **Manufacturer** advises the customer to keep a record of all maintenance jobs performed on the compressor, see **Section 7 – Drawings and diagrams**.

6.1.1 Changing the oil

Read all the information provided in **Section 6.1** before proceeding with any maintenance jobs. Change the oil following the initial **500 hours** of use and then every **2500/300 hours** and in event once a year. **If the compressor is only used for a few hours a day it is advisable to change the oil every 6 months.**



When you open tap 2, oil starts to drain from the screw unit, therefore you need to have a pipe and container ready to collect the oil.

Unscrew the red cap 1 situated at the base of the screw unit.

Screw an attachment with tail piece (supplied together with the compressor).

Open tap 2.

Once emptied, shut-off tap 2 and remove the attachment with tail piece.

Fill-up with oil to the rim of the union 4, then screw cap 1 back in place and close-up the compressor again.

Once the oil and oil filter have been changed leave the compressor to run for roughly 5 minutes then turn it off and check the oil level again.

Check the oil level each month and check that it is up to the rim of the port 4.

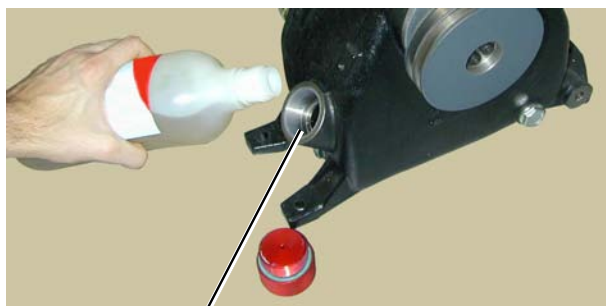
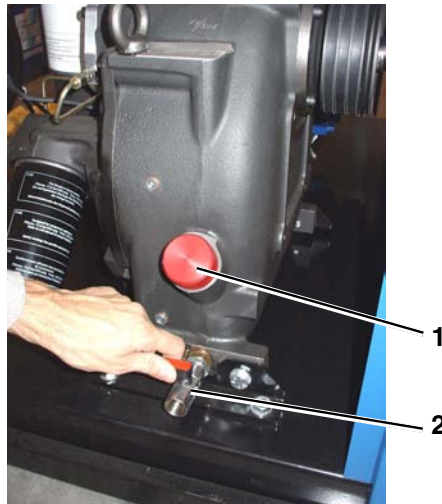

4

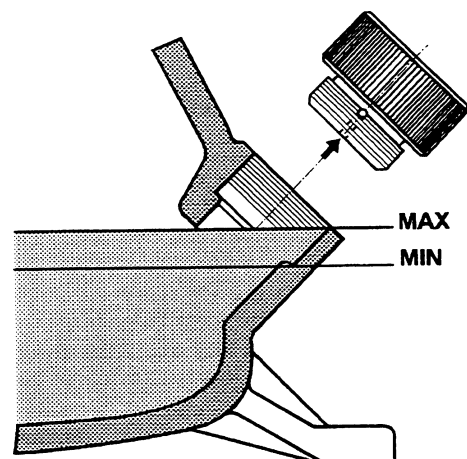

Never mix different types of oil, therefore always ensure that the circuit is completely empty before filling-up with oil. Each time the oil is changed the filter is also to be replaced.

6.1.2 Replacing the oil filter cartridge

Read all indicated in **Section 6.1** before starting any maintenance jobs.

Replace the oil filter cartridge after the first **500 hours** of use then every **2500/3000 hours** and in any event each time the oil is changed.

Open the rear panel.

Disassemble filter cartridge **1**, using a chain spanner and replace with a new one.

Lubricate the sealing gasket before screwing the filter cartridge tight.

Manually tighten the new filter cartridge.

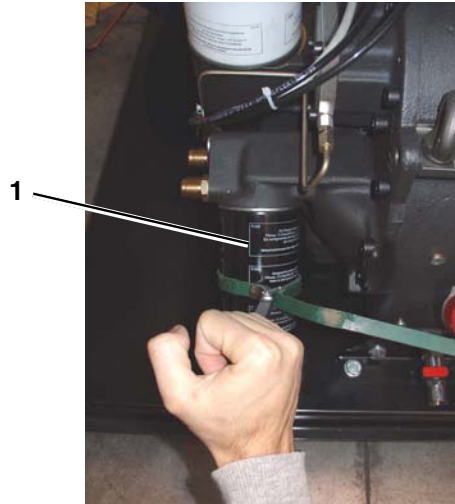

6.1.3 Replacing the filter cartridge of the oil separator

Read all indicated in **Section 6.1** before starting any maintenance jobs.

Open the side LH panel to gain access to inside the compressor.

Disassemble filter cartridge **1**, using a chain spanner and replace with a new one.

Lubricate the sealing gasket before screwing the filter cartridge tight.

Manually tighten the new filter cartridge.

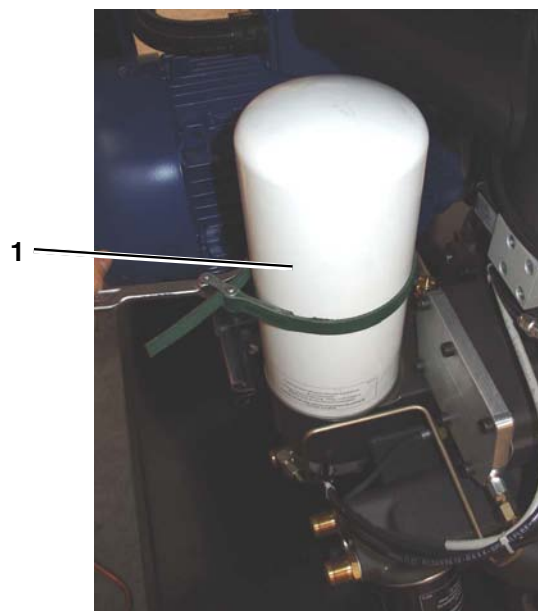

6.1.4 Replacing the air filter cartridge

Read all indicated in **Section 6.1** before starting any maintenance jobs.
 Open the side LH panel to gain access to inside the compressor.
 Remove the screws **2** and also the cover **1**.
 Replace the cartridge of the air filter.



6.1.5 Tightening the belt

Read all indicated in **Section 6.1** before starting any maintenance jobs.
 Open the side LH panel to gain access to inside the compressor.
 Every **500 hours** of use it is advisable to check and maybe tighten the belt if necessary.
 Using a dynamo meter apply a perpendicular force in point **A** of between 25N and 35N, the belt must give by roughly 5mm.
 Turn the nut **1** to tighten the belt.

6.1.6 Replacing the belt

Read all indicated in **Section 6.1** before starting any maintenance jobs.
 Open the side LH and front panel.
 Turn the nut **1** to slacken the belt.
 Slide the belt out, replace it with a new one and tighten as described in the previous section.

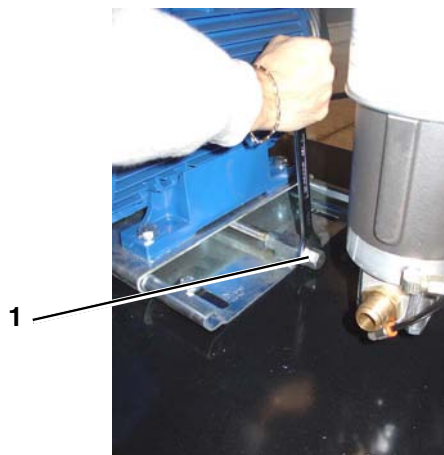
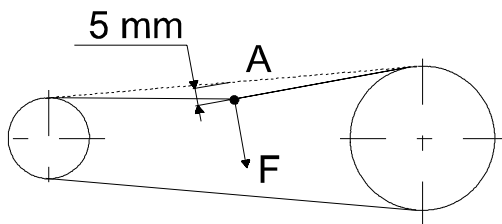

6.1.7 Cleaning the air/oil radiator

Read all indicated in **Section 6.1** before starting any maintenance jobs.
It is advisable to clean the radiator **1** on a weekly basis to remove impurities, blowing it with an air gun from inside. Open the rear panel with quick-release locks and blow compressed air through the radiator, from inside outwards, making sure that no dirt settles inside the compressor



6.1.8 Cleaning the dust-removal pre-filter

Read all indicated in **Section 6.1** before starting any maintenance jobs.
Clean the pre-filter **1** from impurities on a weekly basis.
Slide the pre-filter **1** out and blow with compressed air or replace if necessary.

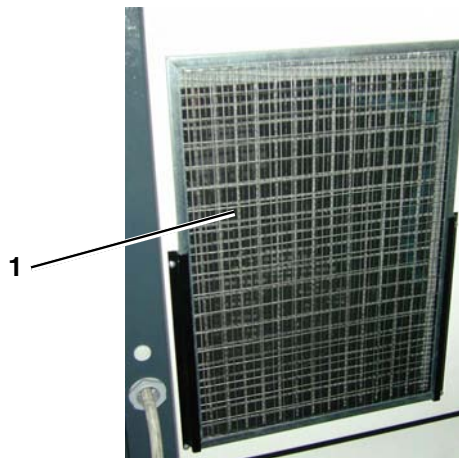

6.1.9 Maintenance the electric motor

The bearings of the electric motor are already lubricated and are maintenance free.
In normal surrounding conditions (ambient temperature up to 30°C) replace the motor bearings every 12000 hours of use. In more severe surrounding conditions (ambient temperature higher than 30°C) replace the motor bearings every 8000 hours of use.
The bearings are to be replaced in any event every 4 years at the most.

Warning! Before replacing the motor bearings, contact our customer service department, as established by the maintenance schedule.

6.1.10 Draining the condensate (only for models equipped with tank)

Read all indicated in **Section 6.1** before starting any maintenance jobs.

Drain the condensate from the air tank at least once a month by opening tap **1** secured to the foot of the tank.



For the pressure switch, drain the condensate at least once a week; when doing so, make sure the machine is stopped and no longer electrically powered.

Get hold of a container to collect the condensate. Open the left hatch of the machine with the dedicated key, slowly open the cock **2**, leave it to blow until you no longer see any condensate coming out of the cock, making sure to drain the condensate into the dedicated container.



The condensate drained is considered as polluting mix that must not be thrown away outdoors. It is advisable to use special water/oil separators for its disposal.

6.2 Diagnosing the alarm status/inconveniences-faults



Before doing any job on the compressor ensure that:

- The main ON/OFF switch is turned Off (position “0”)
- The compressor is shut-off from the compressed air system
- The compressor and the internal pneumatic circuit are completely de-pressurised

If you are unable to rectify the anomaly encountered on your compressor contact your nearest authorised service centre.

COMPRESSOR

Anomalies	Causes	Solutions
<p>The compressor runs in the wrong direction. Message on display "ROTATION ALARM".</p>	<p>The compressor fails to start, the screw unit is running in the wrong direction.</p>	<p>Invert the phase wires, press the "RESET" button on the electronic board and start again.</p>
<p>Oil alarm triggers and the machine stops (red LED). Message on display "TEMPERATURE ALARM". Check the temperature on the display.</p>	<p>Excessive temperature of air/oil mix outlet from the screw (105 °C).</p>	<p>Check the electric connections of the probe. Check the oil level, check if the radiator is clean, check if the pre anti-dust filter is clean, check the ambient temperature, check the minimum distance of the compressor from the walls of the room, check if the soundproof panels are firmly secured in place (pressurization of the ventilation air). To start the machine again, wait for the temperature to drop to 94°C, then press the "RESET" button on the panel of the electronic board. If the problem persists, the thermostat valve could still be closed.</p>
<p>The trip switch of the compressor motor trips and the machine stops (red LED). Message on display "COMP. TRIP SWITCH ALARM"</p>	<p>The trip switch that protects the compressor motor has tripped.</p>	<p>Check if the electric power supply is correct, check if the 3 power supply phases are roughly the same value. Check if the cables are firmly connected to the terminal board, check if the electric cables have melted. Check if the suction grid of the cooling fan of the motor is clean and not clogged with anything (paper, leaves, rags). To start the machine again, see note p.24 – 25.</p>
<p>The trip switch of the fan motor trips and the machine stops (red LED). Message on display "FAN TRIP SWITCH ALARM".</p>	<p>The trip switch that protects the fan motor has tripped.</p>	<p>Check if the electric power supply is correct, check if the 3 power supply phases are roughly the same value. Check if the cables are firmly connected to the terminal board, check if the electric cables have melted check FV fuses. Check if the suction grid of the cooling fan of the motor is clean and not clogged with anything (paper, leaves, rags). To start the machine again, disconnect it from the mains, open the front panel of the compressor, press the reset key in the electric cabinet (see button 3 sect. 5.2.3) and press "RESET" on the board.</p>

Anomalies	Causes	Solutions
Low temperature. Message on display "LOW TEMPERATURE ALARM"	Temperature too low (<-5°C) and the compressor does not start.	Wait for the temperature to rise (higher or equal to -5°C), press "RESET" on the electronic board, and then start again.
The compressor runs but fails to load.	The suction valve fails to open.	Check if the operational pressure switch is working efficiently, check if the solenoid valve fitted on the suction regulator works regularly (Normally Closed solenoid valve).

7 Drawings and diagrams

7.1 Wiring diagrams

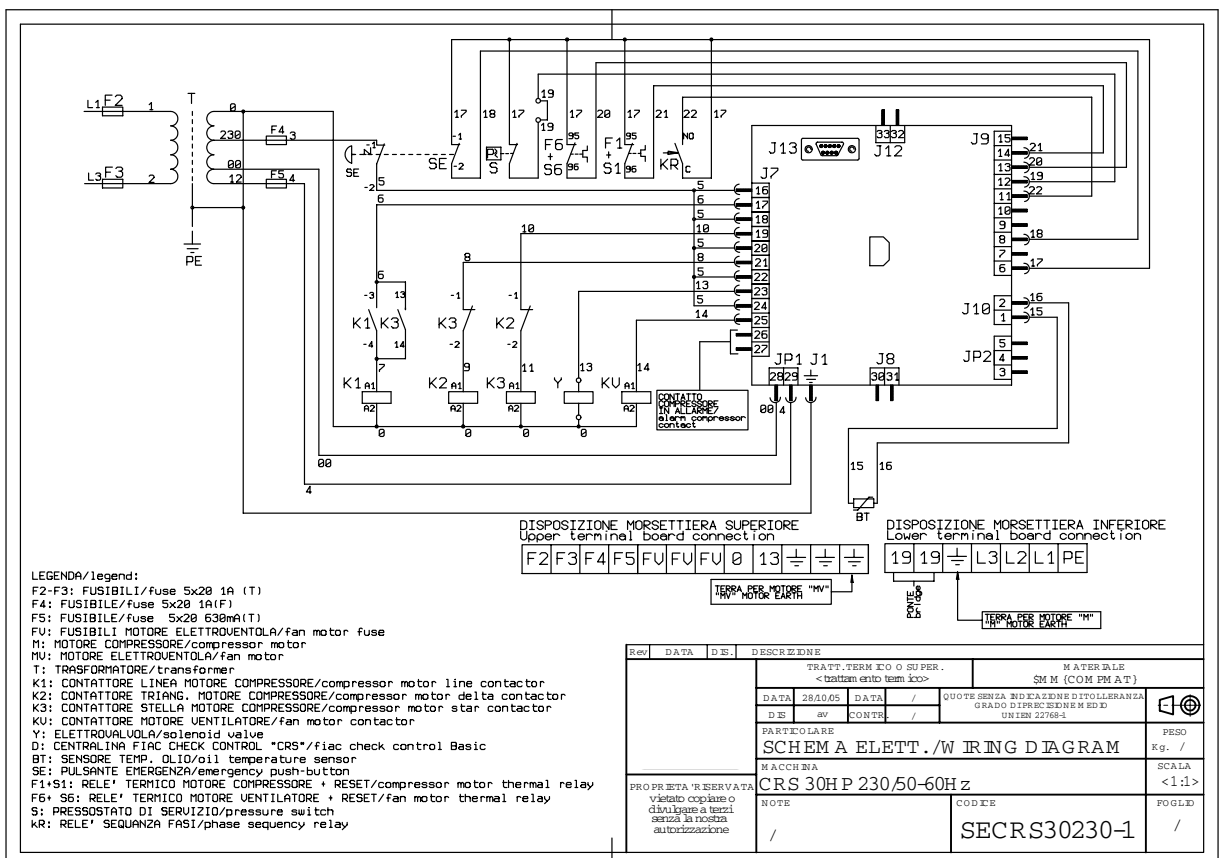
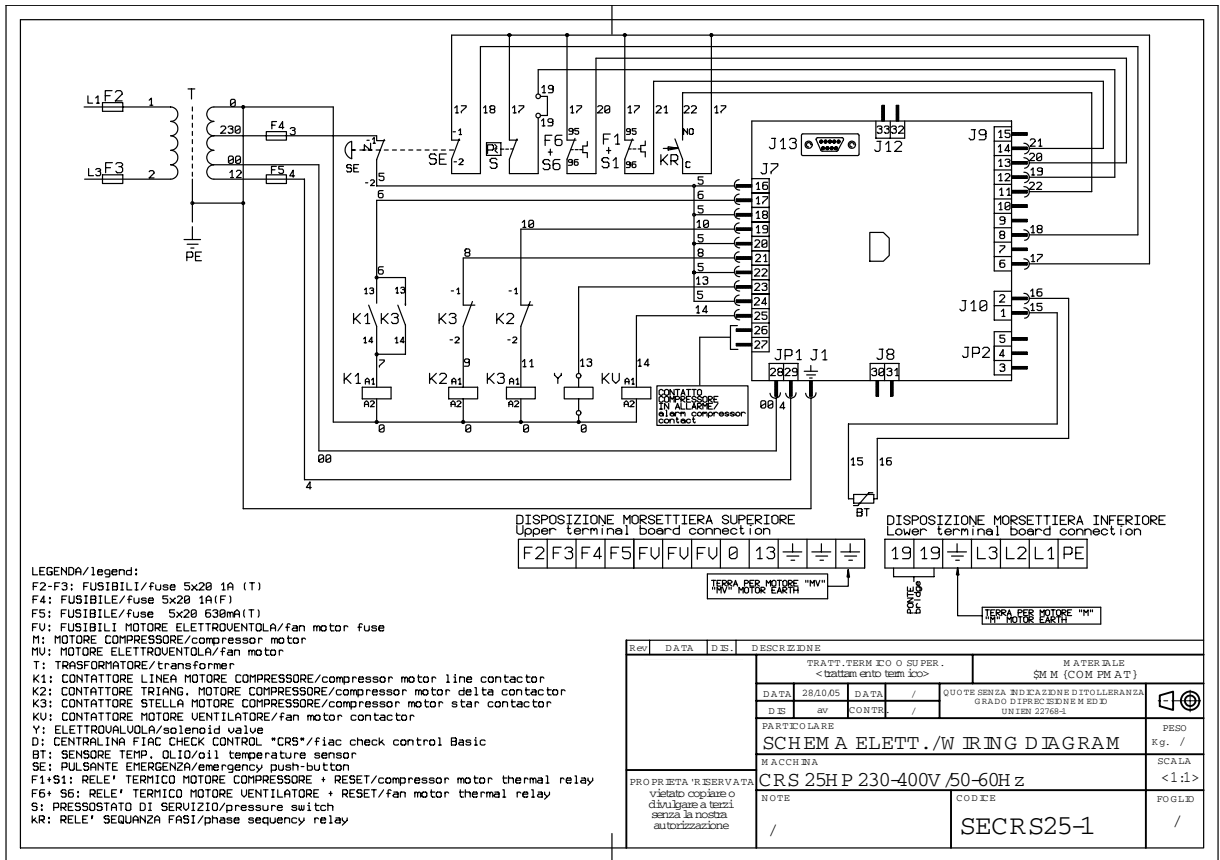

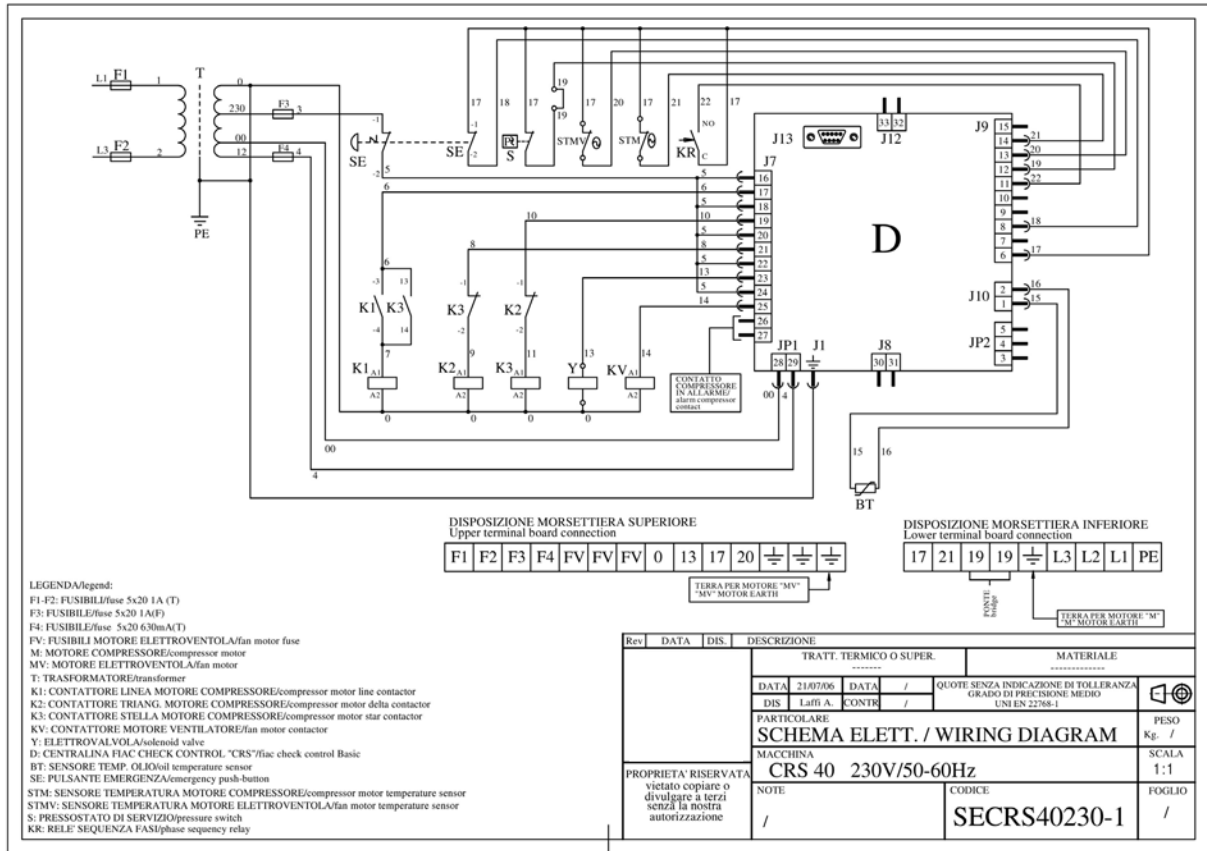
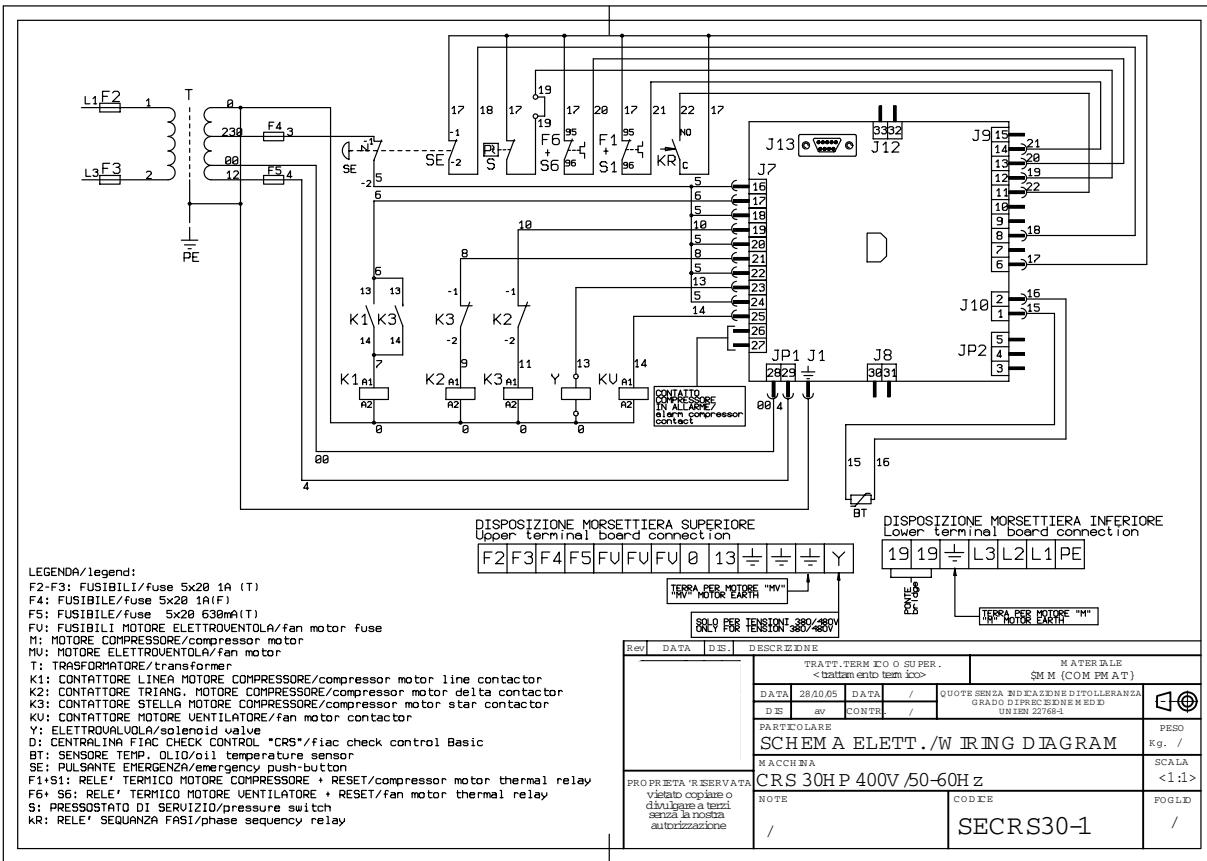

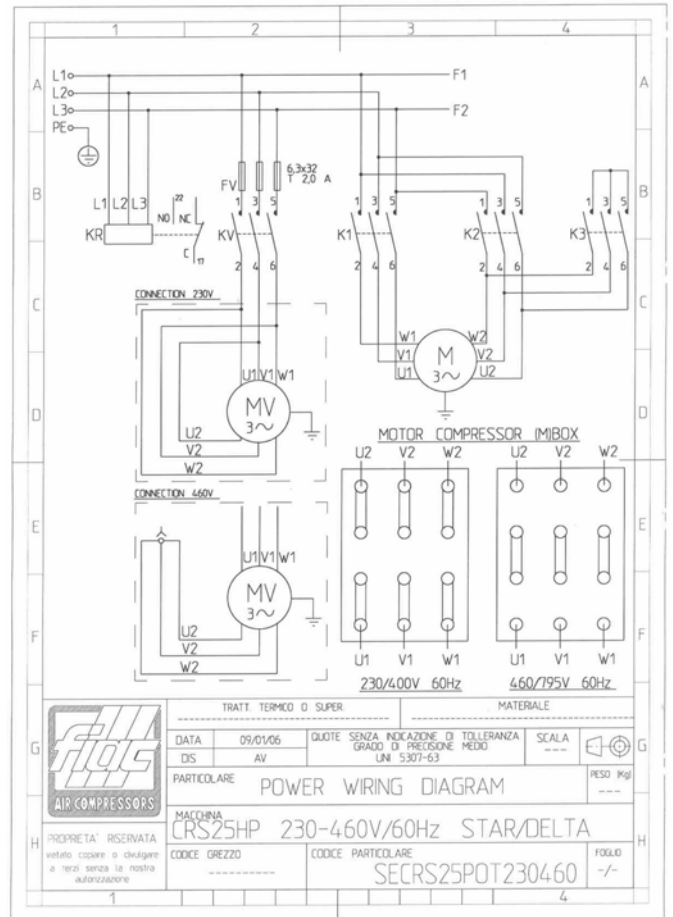
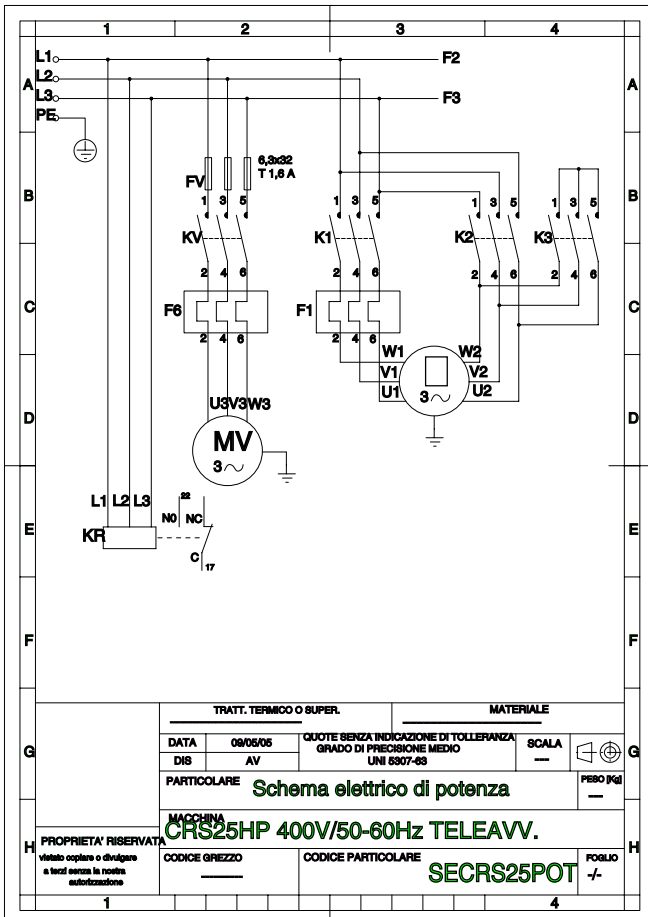
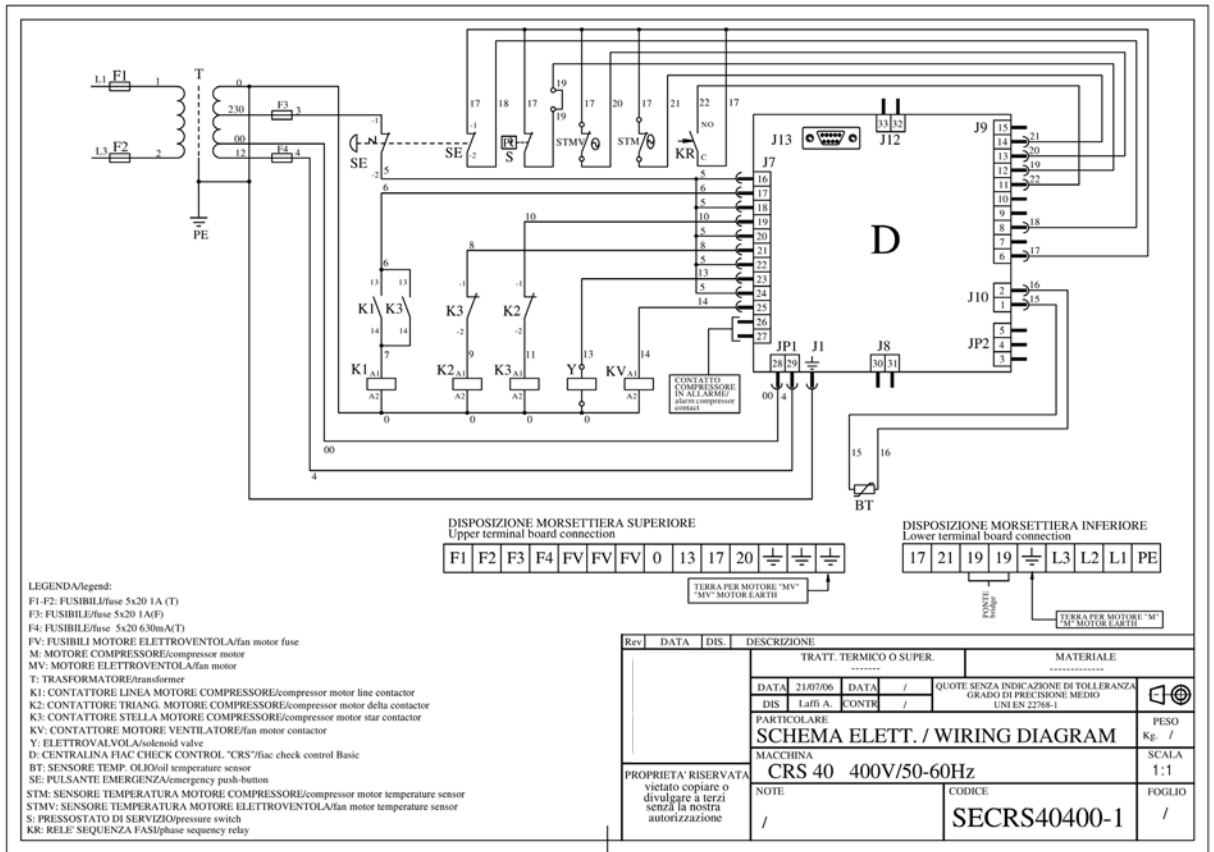

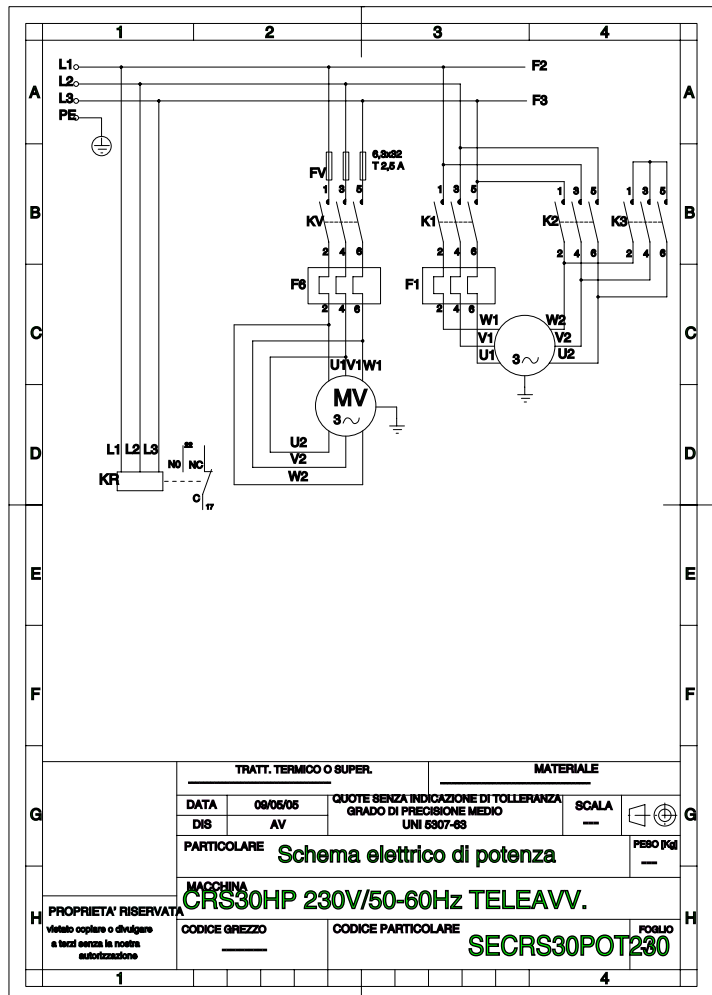
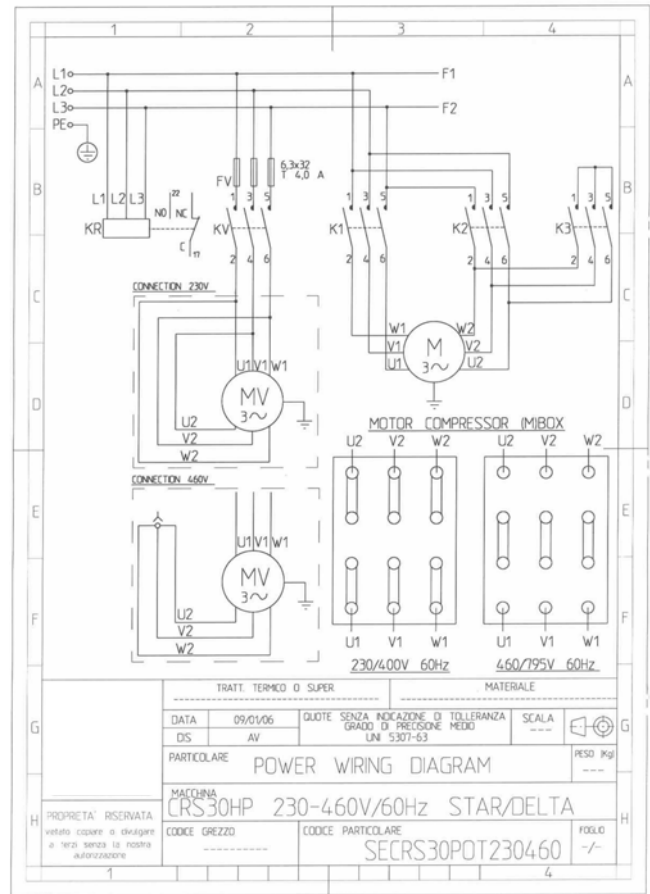
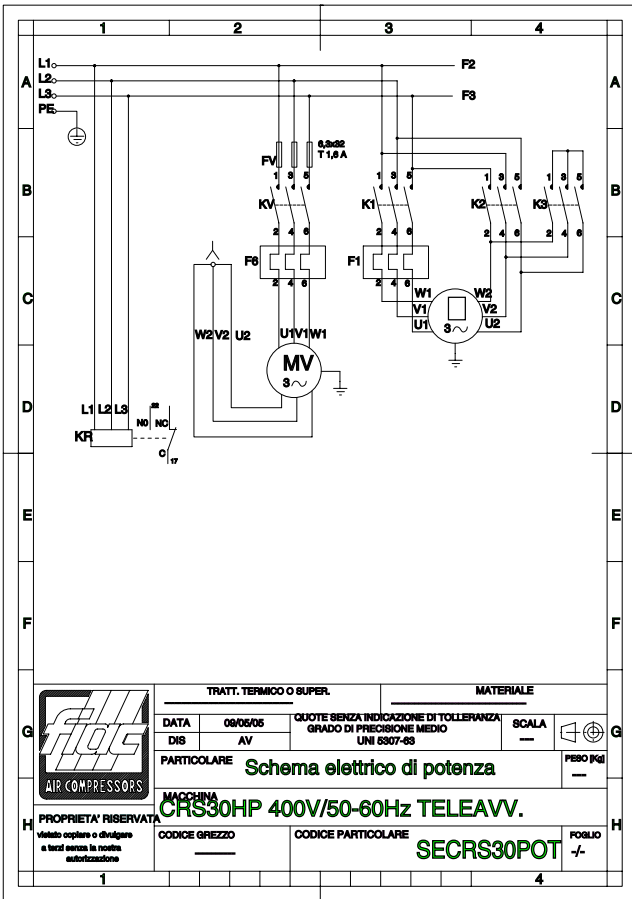

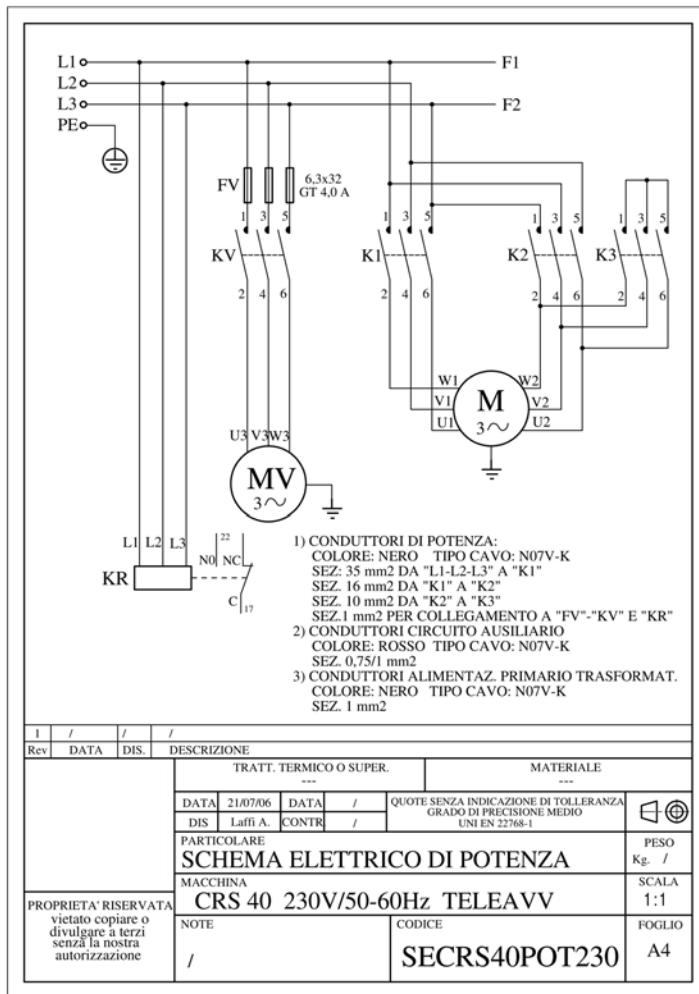
**KEY**

- IG: Main ON/OFF switch
 K: Refrigeration compressor
 KR: Compressor start relay
 KM: Compressor electric motor
 KT: Compressor protection trip switch
 VC: Condenser fan
 EVB: Hot gas by-pass solenoid valve
 EVS: Separator condensate drain solenoid valve
 EVF: Filter condensate drain solenoid valve

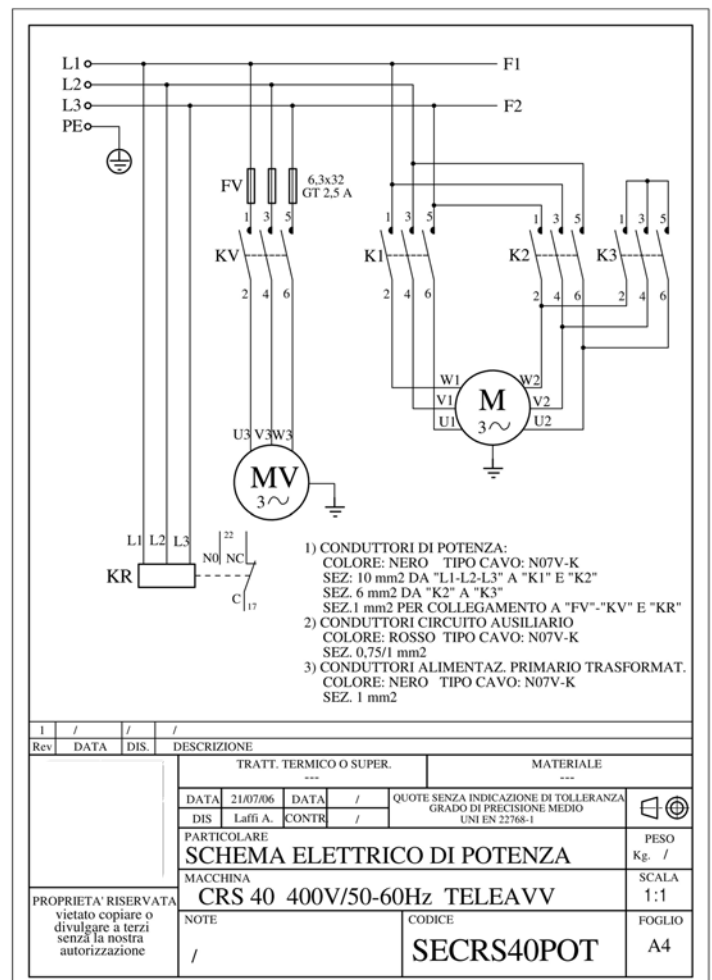

7.2 Pneumatic diagrams

SCHEMA FUNZIONALE/operational diagram

