

*C35 User's Manual*

## Quintet C35™ Handheld Device



User's Manual

## *C35 User's Manual*

Quintet Digital Corporation  
9F-A, 728, Yan'An West Rd., Changning District,  
Shanghai, 200050, China  
Quintet C35 - User's Manual  
Edition: 11/2010

ALL RIGHTS RESERVED

Quintet reserves the right to make modifications and improvements without prior notification.

Quintet shall not be liable for technical or editorial errors or omissions contained herein, nor for incidental or consequential damages resulting from the use of this material.

*Quintet™* is a registered trademark of Quintet Digital Corporation in many countries and the *Quintet™* logo is a trademark of Quintet Digital Corporation. All other brand and product names mentioned herein are for identification purposes only and may be trademarks or registered trademarks of their respective owners.

© Quintet Digital Corporation 2007-2010

# C35 User's Manual

## CONTENTS

<b>Reference.....</b>	<b>5</b>
Reference Documentation.....	5
Services and Support.....	5
<b>Safety Regulation.....</b>	<b>5</b>
General Safety Rules.....	5
Radio Compliance.....	6
FCC Compliance.....	6
<b>Quick Start.....</b>	<b>7</b>
<b>Chapter 1 Introduction .....</b>	<b>8</b>
1.1 Introduction.....	8
1.2 Quintet C35™ Handheld Device Description.....	11
1.3 Package Contents.....	11
1.4 Accessories.....	11
1.5 Operating System .....	12
<b>Chapter 2 Connections.....</b>	<b>13</b>
2.1 Inserting Micro SD Card .....	13
2.2 Installing Battery packs .....	15
2.3 USB Direct Connections .....	16
2.4 Cradle Connections .....	16
2.5 AC Adaptor Connections .....	17
<b>Chapter 3 Use and Functioning.....</b>	<b>16</b>
3.1 PDA Startup.....	16
3.2 Using the Stylus.....	16
3.3 Description of the Keys .....	17
3.4 Status Indicators.....	18
3.5 Control Panel .....	18
3.5.1 Stylus Calibration.....	19
3.5.2 Volume Settings .....	20
3.5.3 Backlight Settings .....	22
3.6 Windows Connections .....	22
<b>Chapter 4 Maintenance.....</b>	<b>24</b>
4.1 Charging the Battery Pack.....	24
4.2 Replacing the Battery Pack .....	24
4.3 Cleaning the PDA .....	26
<b>Chapter 5 Technical Features.....</b>	<b>27</b>
5.1 Technical Data .....	27

## *C35 User's Manual*

5.1.1 Electrical Features.....	27
5.1.2 Environmental Features .....	27
5.1.3 Mechanical Features .....	27
5.1.4 Programming Features.....	27
<b>Glossary</b> .....	<b>28</b>

## Reference

### Reference Documents

For further information regarding Quintet C35™ handheld device refer to the SDK Help on-Line.

### Service and Support

Quintet provides several services as well as technical support through its website.

Log on to [www.rfid-provider.com](http://www.rfid-provider.com) and click on the links indicated for further information including:

#### -- Products

Search through the links to arrive at your product page where you can download specific

#### **Manuals and Software & Utilities**

#### -- Service and support

#### -- Quintet Services Warranty Extensions and Maintenance Agreements

#### --Authorized Repair Center

#### -- Contact us

E-mail form and listing of Quintet Subsidiaries

## Safety Regulations

### Note

*Read this manual carefully before performing any type of connection to the Quintet C35™ handheld device.*

*The user is responsible for any damages caused by incorrect use of the equipment or by inobservance of the indication supplied in this manual.*

## General Safety Rules

- Use only the components supplied by the manufacturer for the specific Quintet C35™ handheld device being used.
- Do not attempt to disassemble the Quintet C35™ handheld device, as it does not contain parts that can be repaired by the user. Any tampering will invalidate the warranty.
- When replacing the battery pack or at the end of the operative life of the Quintet C35™ handheld device, disposal must be performed in compliance with the laws in force..

## *C35 User's Manual*

### Radio Compliance

In radio systems configured with handheld device, the frequencies to be used must be allowed by the spectrum authorities of the specific country in which the installation takes place. Be absolutely sure that the system frequencies are correctly set to be compliant with the spectrum requirements of the country.

The radio modules used in this product automatically adapt to the frequencies set by the system and do not require any parameter settings.

### FCC Compliance

Modifications or changes to this equipment without the expressed written approval of Quintet could void the authority to use the equipment.

This device has been tested and found to comply with the limits for a CLASS B digital device, pursuant to Part 15 of the FCC Rules. These limits are designed to provide reasonable protection against harmful interference when the equipment is operated in a commercial environment. This equipment generates, uses, and can radiate radio frequency energy and, if not installed and used in accordance with the instruction manual, may cause harmful interference to radio communications. Operation of this equipment in a residential area is likely to cause harmful interference in which case the user will be required to correct the interference at his/her own expense.

FCC ID: YAAC35010

**Quick Start:**

1. **Control Panel:** Click "Start" on the top left corner of the home screen, select "Setting" to launch control panel.
2. **Stylus calibration:** Launch "Control Panel", then select "System" tab; Click "Screen", choose "General" tab. Click "adjust" to perform stylus calibration.
3. **Volume:** Launch "Control penal", select "Sound" to adjust the system volume..
4. **Backlight:** Launch "Control Panel", select "Backlight" to adjust the brightness of backlight.
5. **RFID:** Click "Start", selects "Explorer"; click "Up" on the bottom left corner, open "OEM\_APP", then run "RFID\_Reader".
6. **GPS:** Click "Start", selects "Explorer"; click "Up" on the bottom left corner, open "OEM\_APP", then run "GISMapping"
7. **Wi-Fi:** "Start" -> "Setting" -> "Connection" -> "Wi-Fi"
8. **Bluetooth:**  
"Start" -> "Setting" -> "Connection" -> "Bluetooth"
9. **Camera:** "Start" -> "Photo&Video" -> "Camera"

Chapter 1 Introduction

1.1 General View

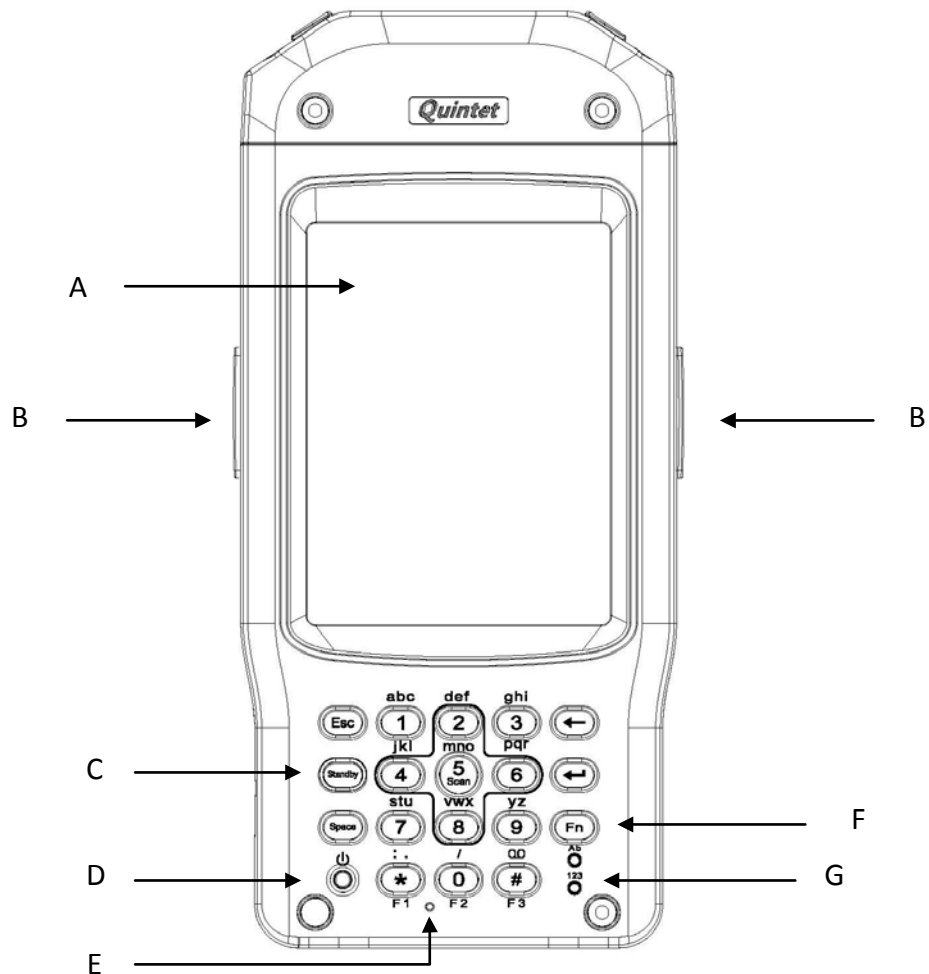

Figure 1 - Top View

- A) Data capture output window
- B) Scan key(s)
- C) Standby & power/charger status LED
- D) Power on/off switch
- E) Microphone input
- F) Keypad input functions rotation key
- G) Alphabetic/Numerical indicator LED



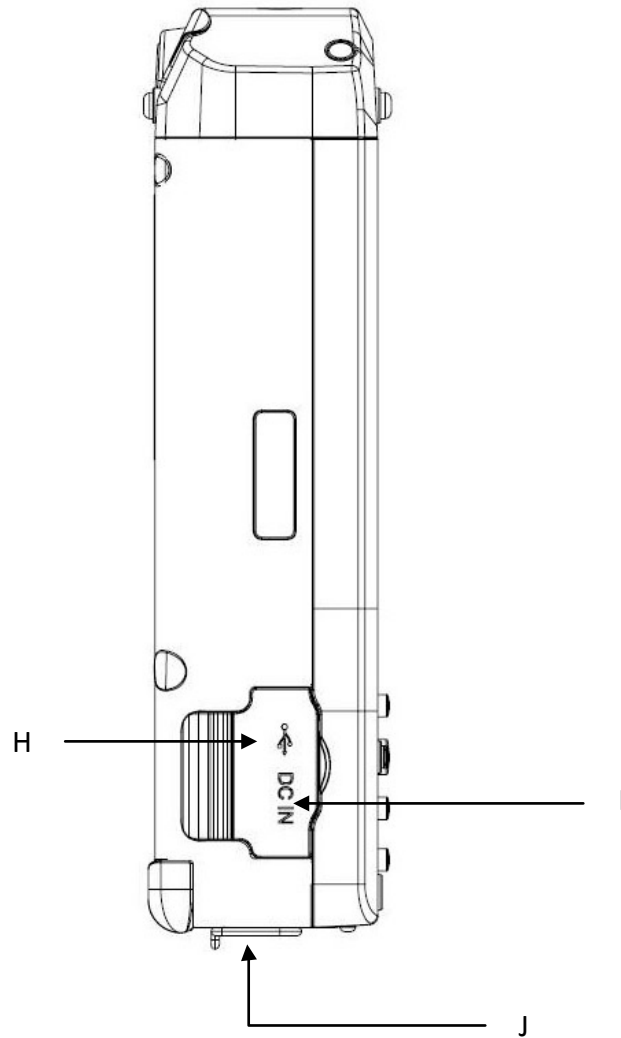

Figure 2 - Side View

H) USB client connector

I ) DC in jack

J) Dock connector

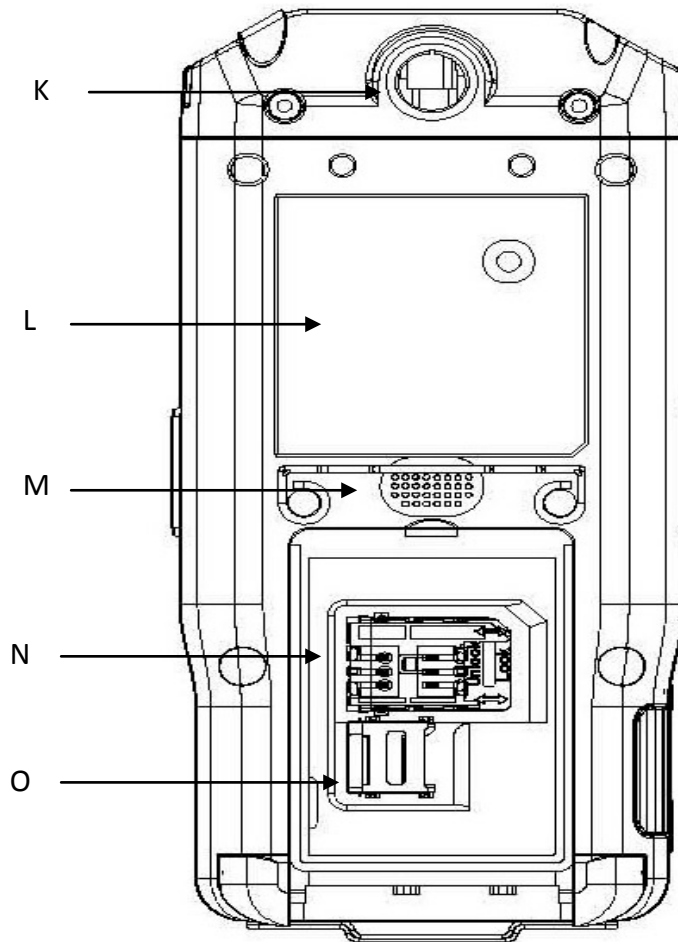

Figure 3 – Bottom View

- K) Camera (reserved)
- L) UHF RFID antenna
- M) Speaker
- N) SIM socket (reserved)
- O) Micro SD socket

## *C35 User's Manual*

### 1.2 Quintet C35™ Handheld Device Description

Thanks for purchasing Quintet C35™ handheld device.

Thanks to the state-of-the-art architecture and the most advanced technologies, it can provide the most suitable levels for capturing, computing and communicating data faster and easier.

The Quintet C35™ is equipped with a function-based interface for direct ERP transactions and with a web-based layout for HTML needs as well. These key requirements make the Quintet C35™ perfect for use in field force automation, in store and logistics applications. The Quintet C35™ enables companies and organizations worldwide to make more effective use of people and tools for receiving, storage, and shipping activities. For example, extended mobility allows simultaneous real-time inventory management and control of all stock movements to increase precision while minimizing operating costs. Data on store shelves, inventory levels and storage bins are immediately available to permit greater coordination and cut flow times.

The Quintet C35™ provides mobile professionals with the most relevant features needed to operate in demanding environments: reliability, ruggedness, drop resistance, long lasting batteries, flexible communication and efficient data capture.

To optimize mobile applications, a user-accessible memory slot is also present to backup data, extend databases, etc.

Thanks to a set of accessories, such as a vehicle cradle, cigarette lighter power adapter, dashboard mounting kit, with state-of-the-art technology inside the PDA, the Quintet C35™ is the right answer for all data management needs on the move.

### 1.3 Package Contents

The Quintet C35™ handheld device package contains:

- 1 Quintet C35™ PDA
- 1 CD-ROM Quintet C35™ Software Development Kit
- 2 Styluses
- 1 User's manual
- 1 Rechargeable battery pack
- 1 Hand grip belt (length adjustable)
- 1 USB data communication cable
- 1 Warranty card

#### **Caution**

*Keep the original packaging for use when sending products to the technical assistance center. Damage caused by improper packaging is not covered under the warranty.*

## *C35 User's Manual*

### 1.4 Accessories

#### **Cradles**

91-C1 Quintet C35™ Single Cradle Desk (includes slot for spare battery pack recharge; RS232 and USB communications)

91-C2 Quintet C35™ Vehicle Cradle Standard

#### **Charger**

91-C3 Quintet C35™ Multi-Battery pack Charger (2 slots)

#### **Batteries**

46-11 Quintet C35™ Standard Battery pack (Li-Ion battery pack 1800 mAh@7.4 V)

46-21 Quintet C35™ Large Capacity Battery pack (Li-Ion battery pack 2800 mAh@7.4 V)

#### **Power Supply**

34-11 Universal 90~265V 47~63Hz 12V/2A adaptor

45-11 Power cord CCC 3-pin

45-21 Power cord UL 3-pin

45-31 Power cord EU 3-pin

#### **Cables**

45-41 USB Cable; cable for USB direct connection between the PDA and the PC

45-51 Vehicle Power Cable; cable for powering Quintet C35™ from the car cigarette lighter

#### **Various**

64-11 Hand Grip Belt

64-21 Stylus Pen

#### **Note**

*Use only a Quintet approved power supply and cables. Use of an alternative power supply will invalidate any approval given to this device and may be dangerous.*

### 1.5 Operating System

Quintet C35™ comes in two different models, respectively supporting Windows CE and Windows Mobile.

For further information regarding Windows Mobile refer to the website:

<http://www.microsoft.com/windowsmobile>.

## Chapter 2 Connections

### 2.1 Inserting Micro SD Card

With Quintet C35™, it is possible to add a Micro SD Card for additional storage capacity. To access the Micro SD card slot, unlock the battery cover at the bottom of Quintet C35™ (see Figure 4, 5) and then proceed as follows:

1. Remove the battery cover
2. Pull out the metal sheet top on the Micro SD card slot to unlock the slot.
3. Open the Micro SD card slot. (see Figure 6)
4. Insert the card and then close the Micro SD card slot.
5. Push in the metal sheet to lock the slot.
6. Install the battery cover

To remove the Micro SD card, repeat the procedure 1 to 6.

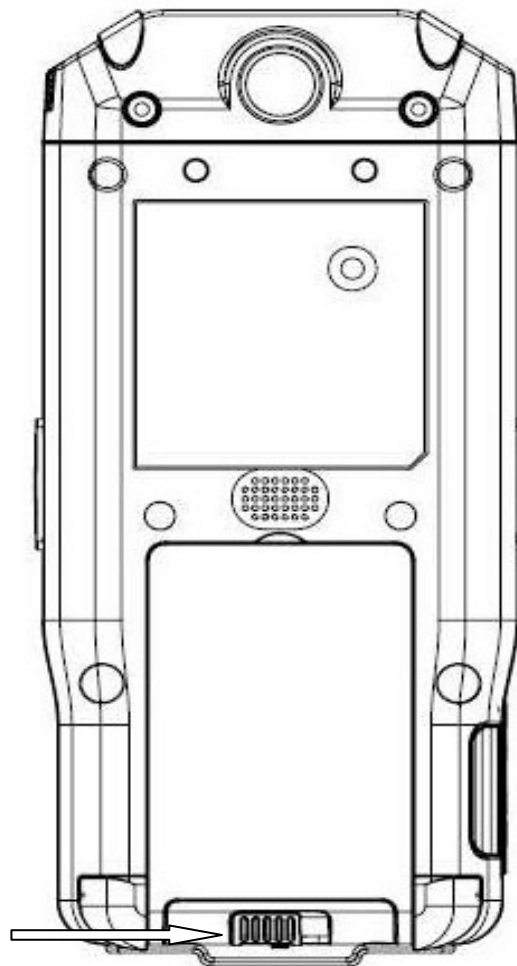

Figure 4

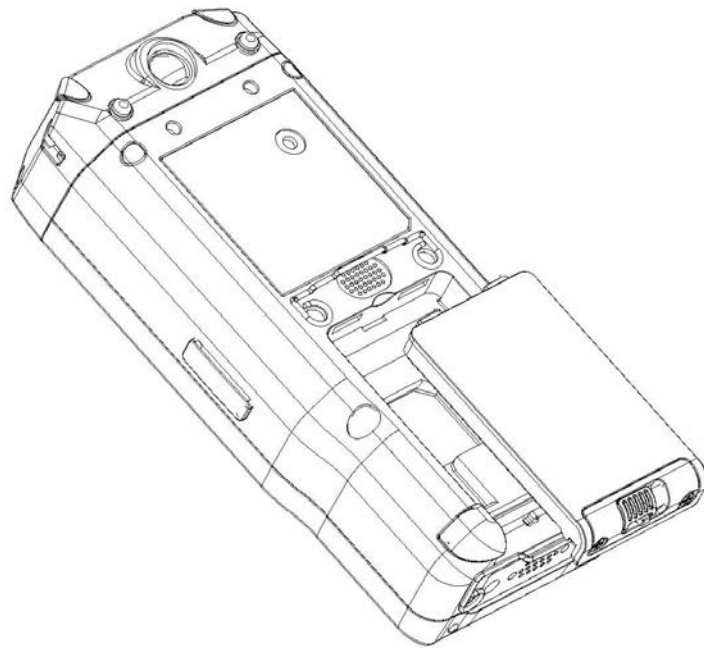

Figure 5

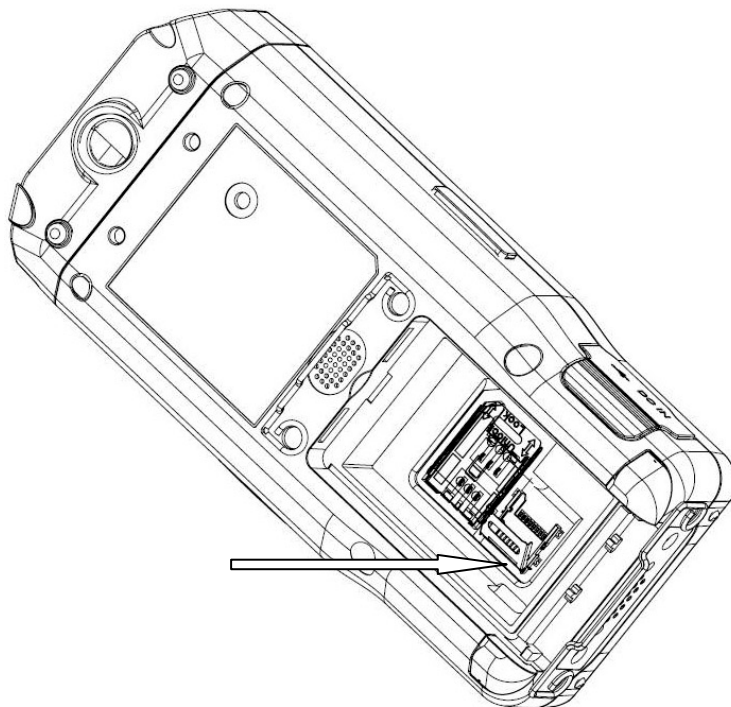

Figure 6

### Caution

*Follow proper ESD precautions to avoid damaging the SD. Proper ESD precautions include, but are not limited to, working on an ESD mat and ensuring that the operator is properly grounded.*

*Do not force the card. If you feel resistance, remove the card, check the orientation, and reinsert it.*

*Do not use the SD card slot for any other accessories.*

## 2.2 Installing battery pack

To access the battery install, unlock the battery cover at the bottom of Quintet C35™ (see Figure 7) and then proceed as follows:

1. Remove the battery cover
2. Insert the battery pack with metal contact pin down.
3. Install the battery cover and lock it.

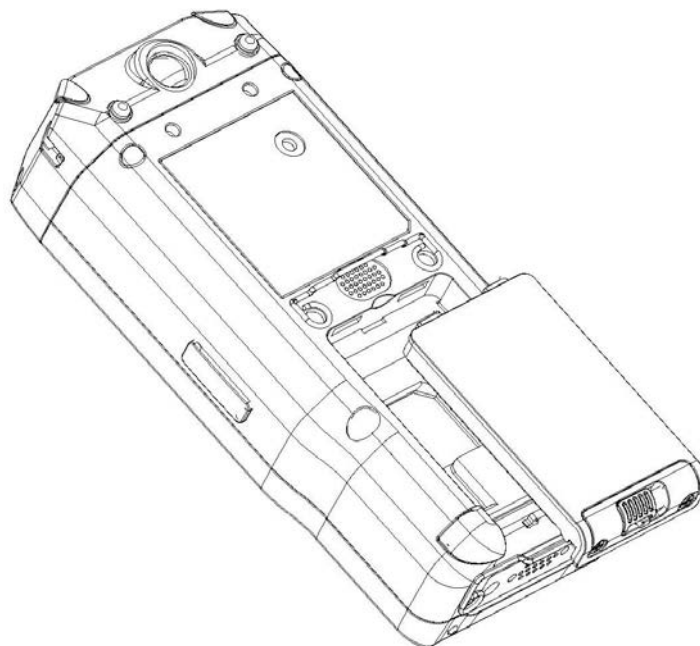

Figure 7

### Note

*Rechargeable battery packs are not initially charged. Therefore the first operation to perform is to charge them.*

# C35 User's Manual

## 2.3 USB Direct Connections

You can use a cable to connect the Quintet C35™ handheld device to a host computer to transfer data.

### Caution

- *USB communication may not be completely guaranteed while batteries are simultaneously in charge. Avoid the power supply connection when the USB link is active.*
- *Windows7/ Vista user need to use Windows Mobile Device Center6.1 on the PC end, XP or earlier version of Windows, please use ActiveSync to synchronize the information with C35™ for detail information please follow the link :*

<http://www.microsoft.com/windowsphone/en-us/howto/wp6/sync/installing-wmdc.aspx>

## 2.4 Cradle Connections

The Quintet C35™ can also communicate via RS232 and USB, using various cradle models. For further details, refer to the specific cradle model User's Manual.

## 2.5 AC Adaptor Connections

The Quintet C35™ may power from AC adaptor, see the Figure 8 for connection instruction.

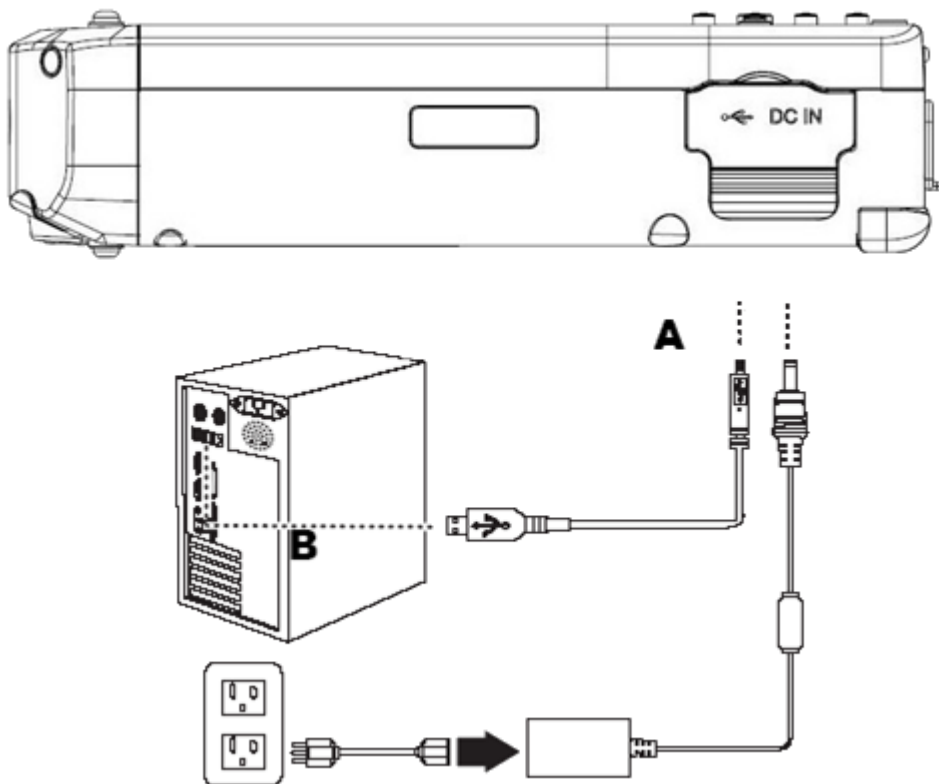

Figure 8



## Chapter 3 Uses and Functioning

The use of the Quintet C35™ handheld device depends on the application software loaded. However there are several parameters that can be set and utilities that can be used to perform some basic functions such as data capture, communications, file management, etc.

### 3.1 PDA Startup

The Quintet C35™ handheld device turns on when the battery pack or the external supply is inserted.

After the battery pack is installed, use the [ON/OFF] key to turn the PDA on and off. As soon as the PDA is on, the Windows CE/ Windows Mobile desktop screen will appear. Wait a few seconds before starting any activity so that the PDA completes its startup procedure.

When it is no longer used for more than a programmable timeout, which is defined in the Power applet of the Control Panel, the PDA goes into power-off (low power with display and keyboard backlight off). In this mode it can be awakened (resuming operation) by the [Standby] key.

#### NOTE

*The PDA can also be awakened or turned off by the application program.*

### 3.2 Using the Stylus

The stylus selects items and enters information. The stylus functions like a mouse.

**Tap:** Touch the screen once with the stylus to open items and select options (Windows Mobile only).

**Double Tap:** Touch the screen twice with the stylus to open items and select options (Windows CE only).

**Drag:** Hold the stylus on the screen and drag across the screen to select text and images. Drag in a list to select multiple items.

**Tap-and-hold:**

Tap and hold the stylus on an item to see a list of actions available for that item. On the pop-up menu that appears, tap the action you want to perform.

Figure 9

**Caution**

*Use only original Quintet styluses supplied with the product itself.*

*In harsh applications, use of screen protectors should be taken into consideration, in order to extend the touch screen operating life.*

*To prevent damage to the screen, do not use sharp devices or any device other than the Quintet-provided stylus.*

*Do not apply not necessary high pressures on the screen.*

*For applications where an intensive use of the touch screen is foreseen, please consider that touch screen components are subject to progressive wear.*

### 3.3 Description of the Keys

The Quintet C35™ provides a function-oriented keyboard having a total of 19 keys.

The keyboard can be divided as follows:

**Power ON/OFF key**

Power ON/OFF the Quintet C35™ handheld device while press the key.

**Standby key**

Switch off the backlight for saving power while press.

**Fn key**

Rotate with Navigation, Alphabetic and Numerical while press the key.

## *C35 User's Manual*

### **System Control and Navigation Keys**

They let you move forwards or backwards within the Internet Explorer browser pages. They let you move forwards, backwards, upwards or downwards within Text fields, scroll through a Menu list or browse among folder files.

### **3.4 Status Indicators**

The Quintet C35™ provides two different LEDs signaling the PDA status.

#### **Power on/Charging status LED: Green/Amber (left side)**

Green constant: It is constant once the charging process has been completed.

Amber blinking: It blinks when the battery pack is running down.

Amber constant: It is constant while charging.

Green/Amber blinking: It blinks while battery pack has errors occurred while in charging process.

#### **Alphabetic/Numerical LED: Green/Red (right side)**

Green: It is constant green in alphabetic mode.

Red: It is constant red in numerical mode.

### **3.5 Control Panel**

From the Windows CE Desktop, double tap on the "Control Panel" icon to open the Windows CE control panel main window. The Control Panel can also be launched from Start ->Settings ->Control Panel.

Figure 10

Figure 11

## *C35 User's Manual*

### 3.5.1 Stylus Calibration

You might need to recalibrate the touch screen (i.e. when you attempt to select one item with the stylus, another item is erroneously selected).

To recalibrate the touch screen on Windows CE, complete the following steps:

1. Select **Start > Settings > Control Panel > Stylus** to open the **Stylus Properties** dialog as shown in Figure 12.
2. Adjust **Double-Tap** sensitivity if needed or desired.
3. Select the **Calibration** tab to open the **Calibration** application.
4. Tap **Recalibrate** to open the **Calibration** screen shown in Figure 13.
5. Carefully press and briefly hold stylus on the center of the target. Repeat as the target moves around the screen. Press the **<ESC>** key to cancel the stylus calibration.
6. Press the **<ENTER>** key or tap the screen to accept the new calibration settings.
7. Press the **<ESC>** key to keep the old settings.
8. New calibration settings are persistently saved in registry.

Figure 12

Figure 13

### **Startup stylus calibration on Windows CE**

When starting the terminal, a stylus calibration screen comes up if valid calibration settings are not available. This happens in the following circumstances:

1. At the first startup of the terminal.
2. After restoring registry default settings using the applet **Registry Admin** and performing a warm boot.

## C35 User's Manual

3. After a **Clean Boot**.
4. After a **Firmware Update**

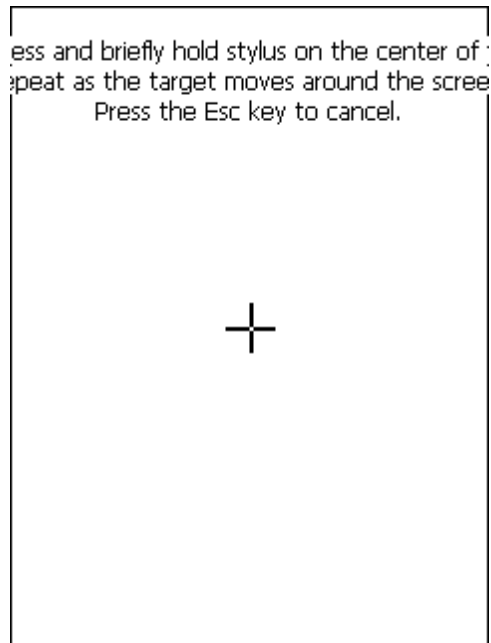

Figure 14

### 3.5.2 Volume Settings

From the Windows CE control panel main window, select the **Volume Settings** applet by double tapping the Volume Settings icon.

The Volume Settings applet allows managing the audio features and appears as follows:

Figure 15

Figure 16

## *C35 User's Manual*

### 3.5.3 Backlight Settings

From the Windows CE control panel main windows, select the **My Backlight** applet by double tapping the **My Backlight** icon

The backlight Settings applet allows managing the backlight features and appears as follows:

Figure 17

Figure 18

## 3.6 Windows Connections

### **Microsoft® ActiveSync®**

Microsoft® ActiveSync® gives you the possibility to connect your desktop computer to your Quintet C35™ handheld device and synchronize the information on them.

Synchronization compares the data on the Quintet C35™ handheld device with that on the desktop computer and updates both computers with the most recent information.

With ActiveSync®, it is possible to:

- Backup and restore Quintet C35™ data.
- Copy files between Quintet C35™ and desktop computer.
- Synchronize files by selecting a synchronization mode.

You can establish an ActiveSync® connection to your Quintet C35™ through the following electrical interfaces:

**RS232** through the Quintet C35™ Single Cradle

**USB** either directly or through the Quintet C35™ Single Cradle

### NOTE

*By default, ActiveSync® does not automatically synchronize all types of information. Use ActiveSync® options to turn synchronization on and off for specific information types.*

For example:

Synchronize Microsoft Word and Microsoft Excel files between the Quintet C35™ PDA and the desktop computer. The files will automatically be converted to the correct format.

### NOTE

*Visit the following Microsoft Web site for the latest in updates and technical information:  
<http://www.microsoft.com/windowsmobile/activesync/default.aspx>*

## Chapter 4 Maintenance

### NOTE

*Rechargeable battery packs are not initially charged. Therefore the first operation to perform is to charge them. See below.*

### 4.1 Charging the Battery Pack

It is possible to recharge the battery pack by using the AC adaptor directly connected to the Quintet C35™ handheld device, see par. 2.5. Alternatively, it is also possible to recharge the battery pack by using the Quintet C35™ Single Cradle Desk or the Quintet C35™ Vehicle Cradle.

The charging process is signaled by a bi-colored charging status LED positioned at the right side of the display (see par. 3.4).

When the battery pack is low, the amber LED positioned at the left side of the display blinks.

If the battery pack is removed from the PDA, it can be recharged by inserting it into the Quintet C35™ Multi-Battery pack Charger.

### NOTE

*The battery pack autonomy varies according to many factors, such as the frequency of barcode scanning, RF usage, battery life, storage, environmental conditions, etc.*

### CAUTION

*If the battery pack is new or has not been recharged for a long time, it is necessary to perform two or three charging and discharging cycles (complete use) before it can reach its maximum charge capability.*

*The maximum time required to recharge a completely run-down battery pack is about 2.5 hours for Li-Ion batteries.*

### NOTE

*Even if the storage temperature range is wider, In order to achieve the longest battery life, store the terminal and the spare batteries between 20 to 30 °C (68 to 86 °F).*

*The Batteries must be charged at a temperature ranging from 0° to +45 °C (+32° to +113 °F).*



## C35 User's Manual

### 4.2 Replacing the Battery Pack

To correctly replace the battery pack, proceed as follows.

1. Turn off the Quintet C35™ handheld device.
2. Press the latch release button and pull the battery latch down as indicated in the figures below:
3. Remove the battery pack.
4. Replace the battery pack by pressing the latch release button and pulling the battery latch down, and then by inserting it towards the speaker and pressing it into the Quintet C35™ PDA until the battery latch is automatically closed.

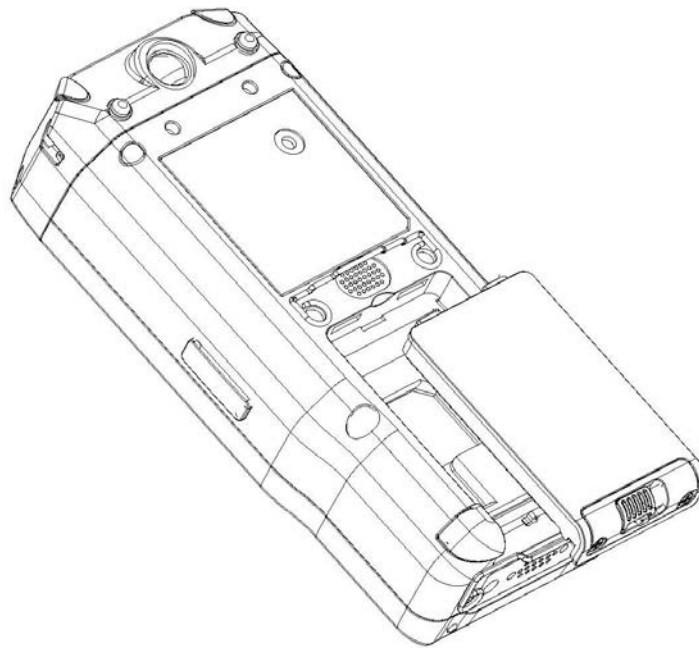

Figure 19

#### CAUTION

*When the latch release button is pressed, the PDA automatically shuts off, in order to retain data during the pack substitution. After the new pack insertion, be sure that the battery latch has completely slid over the pack so that the latch release button is released.*

### WARNING

*Use only a Quintet C35™ approved power supply. Use of an alternative power supply will void the product warranty and may cause product damage. Do not apply voltages to the batteries contacts.*

*Risk of explosion if the battery is replaced by an incorrect type. Do not use the batteries of this terminal to power devices different from this mobile computer.*

*Do not place the battery in or near a fire or heat as they may explode.*

*Do not place the battery in direct sunlight or use or store the battery inside unventilated areas in hot weather. Doing so may cause the battery to generate heat, explode or ignite. Using the battery in this manner may also result in a loss of performance and a shortened life expectancy.*

*Do not place the battery in microwave ovens, high pressure containers, or on induction cookware.*

*Immediately discontinue use of battery if, while using, charging or storing the battery, the battery emits an unusual smell, feels hot, changes color or shape, or appears abnormal in any other way.*

*Do not short-circuit the battery contacts. Accidental short-circuiting can occur when a metallic object such as a coin, clip, or pen causes direct connection of the contacts of the battery (these look like metal strips on the battery).*

*Do not carry or store battery pack together with metal objects (this might happen, for example, when you carry a spare battery in your pocket or purse). Short-circuiting the terminals may damage the battery or the connecting object.*

*Do not pierce the battery pack with nails, strike it with a hammer, step on it or otherwise subject it to strong impacts or shocks.*

*Do not solder directly onto the battery pack.*

*Do not disassemble or modify the battery. The battery contains safety and protection devices, which, if damaged, may cause the battery to generate heat, explode or ignite.*

*Do not expose the battery pack to liquids.*

### NOTE

*In order to guarantee an adequate operating autonomy, when replacing the battery pack the PDA checks the battery energy level.*

*If the battery is not sufficiently charged, Quintet C35™ does not turn on (when pressing the ON button).*

*In this case, either substitute the battery pack with a charged one (sufficiently charged) or insert Quintet C35™ into a powered cradle or plug it into the direct power supply.*

**NOTE**

*To achieve the best battery life, turn off the radios not in use.*

### 4.3 Cleaning the PDA

Periodically clean the Quintet C35™ handheld device with a slightly dampened cloth.

Do not use alcohol, corrosive products or solvents.

## Chapter 5 Technical Features

### 5.1 Technical Data

#### 5.1.1 Electrical Features

##### *Power*

AC/DC supply 12 V 2A

Battery pack 2 cell Li-Ion 1800 mAh@ 7.4 V (nominal)

Large capacity pack 2 cell Li-Ion 2600 mAh@ 7.4 V (nominal)

Internal backup battery Rechargeable Li-Ion 11 mAh

##### *Hardware Features*

FLASH 128 MB

DRAM 128 MB

Microprocessor Samsung S3C2443 400 MHz

Accessible card socket Micro SD

Audio Speaker, Microphone

Alphabetic/Numerical indication LED

Charging Status (two-color LED)

Display 64K Color TFT LCD with 320 x 240 pixel resolution, with LED backlight and touch screen

Keyboard 19 rubber Keys plus Power Button plus 2 Side-Keys for RFID triggers

#### 5.1.2 Environmental Features

Working temperature, -20° to + 50 °C

Storage temperature, -30° to +70 °C

Humidity, 90% non condensing for temperatures < 40°C

Protection IP65

ESD protection, 8 KV contact discharge, 15 KV air discharge

Drop resistance, 1.2 m / 4 ft

#### 5.1.3 Mechanical Features

Dimensions (L x W x H), 17.5 x 8.2 x 4.1 cm

Weight, 540 g (incl. battery)

#### 5.1.4 Programming Features

Operating system Windows CE 6.0 Professional

## *C35 User's Manual*

### Glossary

#### **Access Point**

A device that provides transparent access between Ethernet wired networks and IEEE 802.11 interoperable radio-equipped mobile units. Hand-held terminals, PDAs or other devices equipped with radio cards, communicate with wired networks using Access Points (AP). The mobile unit (PDA), may roam among the APs in the same subnet while maintaining a continuous, seamless connection to the wired network.

#### **Barcode**

A pattern of variable width bars and spaces which represents numeric or alphanumeric data in binary form. The general format of a barcode symbol consists of a leading margin, start character, data or message character, check character (if any), stop character, and trailing margin. Within this framework, each recognizable symbology uses its own unique format.

#### **Baud Rate**

A measure for data transmission speed.

#### **Bit**

Binary digit. One bit is the basic unit of binary information. Generally, eight consecutive bits compose one byte of data. The pattern of 0 and 1 values within the byte determines its meaning.

#### **Bits per Second (bps)**

Number of bits transmitted or received per second.

#### **Bluetooth®**

A standard radio technology using a proprietary protocol. The onboard Bluetooth module in the PDA is compatible with the 1.2 protocol.

#### **Byte**

On an addressable boundary, eight adjacent binary digits (0 and 1) combined in a pattern to represent a specific character or numeric value. Bits are numbered from the right, 0 through 7, with bit 0 the low-order bit. One byte in memory can be used to store one ASCII character.

## *C35 User's Manual*

### **Decode**

To recognize a bar code symbology (*e.g.*, Codabar, Code 128, Code 3 of 9, UPC/EAN, etc.) and analyze the content of the bar code scanned.

### **EEPROM**

Electrically Erasable Programmable Read-Only Memory. An on-board non-volatile memory chip.

### **Flash Disk**

Non-volatile memory for storing application and configuration files.

### **GSM**

Global System for Mobile communication. It is a standard for digital cellular communications, currently used in the 900 MHz and 1800 MHz bands.

### **GPRS**

General Packet Radio Service. GPRS is a wireless packet-based communication service based on GSM. Its data transfer is rated between 56 Kbps to 114 Kbps. It makes very efficient use of available radio spectrum, and users pay only for the volume of data sent and received.

### **GPS**

Global Positioning System. GPS is the only fully functional Global Navigation Satellite System (GNSS). Utilizing a constellation of at least 24 Medium Earth Orbit satellites that transmit precise microwave signals, the system enables a GPS receiver to determine its location, speed, direction, and time. Developed by the United States Department of Defense, GPS is officially named NAVSTAR GPS. The satellite constellation is managed by the United States Air Force 50th Space Wing.

### **Host**

A computer that serves other terminals in a network, providing services such as network control, database access, special programs, supervisory programs, or programming languages.

## *C35 User's Manual*

### **Liquid Crystal Display (LCD)**

A display that uses liquid crystal sealed between two glass plates. The crystals are excited by precise electrical charges, causing them to reflect light outside according to their bias. They use little electricity and react relatively quickly. They require external light to reflect their information to the user.

### **Light Emitting Diode (LED)**

A low power electronic light source commonly used as an indicator light. It uses less power than an incandescent light bulb but more than a Liquid Crystal Display (LCD).

### **PDA**

Personal Digital Assistant. PDA is a term for any small mobile hand-held device that provides computing and information storage and retrieval capabilities for personal or business use, often for keeping schedule calendars and address book information handy.

### **RAM**

Random Access Memory. Data in RAM can be accessed in random order, and quickly written and read.

### **RF**

Radio Frequency.

### **RFID (Radio frequency identification)**

A technology that incorporates the use of electromagnetic or electrostatic coupling in the radio frequency (RF) portion of the electromagnetic spectrum to uniquely identify an object, animal, or person. RFID is coming into increasing use in industry as an alternative to the barcode identification.