

***Uninterruptible Power  
Supply  
Gruppo di Continuità***

**User Manual  
Manuale d'Uso**

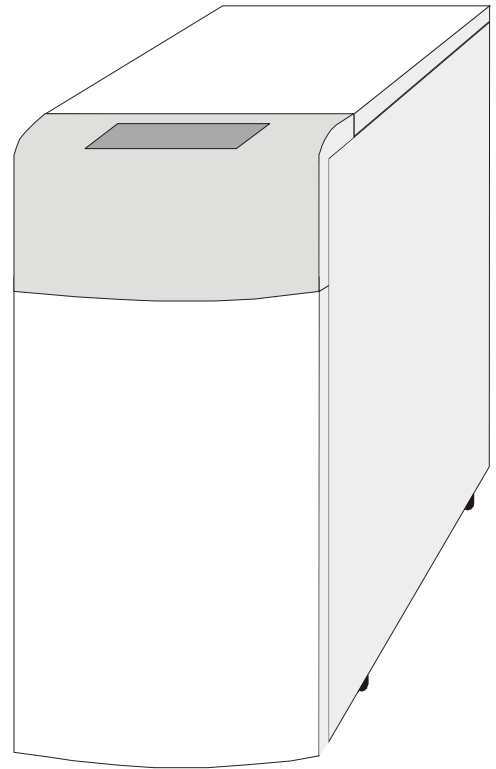

***10÷20kVA***

**Singlephase Output / Uscita Monofase**

***10÷30kVA***

**Threephase Output / Uscita Trifase**

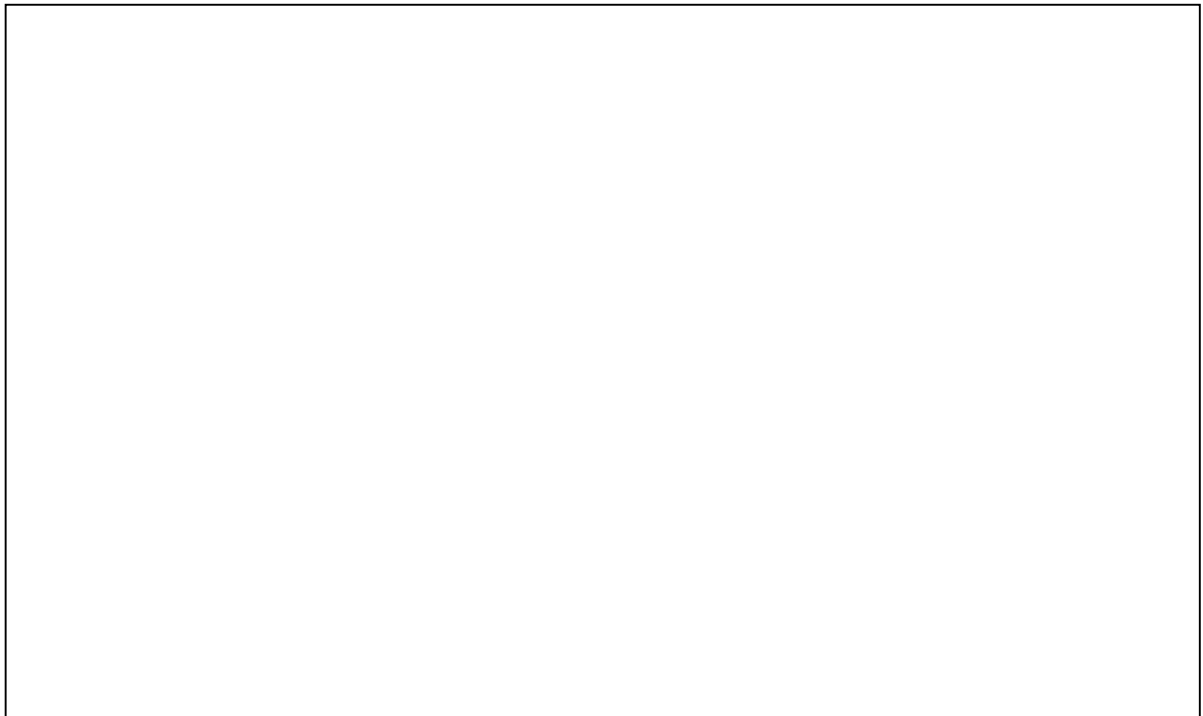

## ATTENTION

This manual contains instructions concerning the installation and putting into operation of the UPS. Read the manual carefully before carrying out installation, which must be done by a trained person.

Because this manual contains essential information on the usage of the equipment, it must be kept in a safe place and consulted before operating on the UPS.

## SAFETY REGULATIONS

- the ups must not be used unless it is connected to earth
- the first connection to make is the connection between the grounding lead and the terminal indicated with the symbol: 
- high voltages are present inside the equipment even when the input and battery switches are open.
- all maintenance operations inside the UPS must be carried out only by trained personnel.
- if it is necessary to replace the fuses, they must be replaced with other fuses of the same type.
- to interrupt the power supply to the utilities in dangerous conditions, open all the switches located behind the front door, or remove EPO connector.

THE BATTERY SHOULD BE CHANGED IF NECESSARY ONLY BY QUALIFIED PERSONNEL. TO ELIMINATE REPLACED PARTS IT IS OBLIGATORY TO DELIVER THEM TO ONE OF THE SPECIAL CONSORTIUMS FOR DISPOSAL BY RECYCLING. THE BATTERIES ARE CLASSIFIED TOXIC WASTE BY LAW.

The Company reserves the right to make changes to the product described in this manual at any time and without notice for reasons of improvement.

## EMC REQUIREMENTS

Uninterruptible Power Supply (UPS) "UPS " models, marked CE and used following the instructions listed below, have the essential requirements to comply with the EMC directive 89/336 and 92/31 and 93/68 ECC.

### **Usage instructions.**

The "UPS" are UPS dedicated to a professional usage in an industrial and commercial environment.

The connection to "REMOTE" and "RS232" connectors must be done by means of a shielded cable.

**WARNING: The " UPS " standard is a Class A-UPS Product.**

**In a domestic environment, this product may cause radio interference, in which case, the user may be required to take additional measures.**

For instance: in case of disturbances received by a radio or a television set, the "UPS " shall be moved in order to increase the distance from above mentioned devices.

# INDEX

<b>LAYOUT</b> .....	<b>5</b>
<b>STORAGE</b> .....	<b>5</b>
<b>INSTALLATION NOTE</b> .....	<b>6</b>
<b>PRELIMINARY OPERATIONS</b> .....	<b>6</b>
<i>INSTALLATION ROOM</i> .....	6
<i>POSITIONING</i> .....	7
<b>SETTING UP THE ELECTRICAL SYSTEM</b> .....	<b>7</b>
<b>PROTECTIONS</b> .....	7
<i>Inside the UPS</i> .....	7
<i>UPS Input</i> .....	7
<i>UPS output, Short circuits and selectivity</i> .....	7
<i>Differential</i> .....	8
<b>CONNECTIONS</b> .....	<b>8</b>
<i>PRELIMINARY OPERATIONS FOR OPENING UPS</i> .....	8
<b>MAINS AND LOAD CONNECTIONS</b> .....	9
<i>Single phase output</i> .....	9
<i>Threephase output (input threephase only)</i> .....	10
<b>BATTERIES CONNECTIONS</b> .....	10
<i>Internal battery cabinet</i> .....	10
<i>External battery cabinet</i> .....	10
<b>REMOTE CONTROL AND SIGNALS</b> .....	11
<i>EPO connector, Emergency power off (pos. A)</i> .....	11
<i>15-pin female marked REMOTE</i> .....	11
<i>SYSTEM OFF (the Command is memorised)</i> .....	11
<i>RS232</i> .....	11
<i>SNMP connector, Simple Network Management protocol (optional)</i> .....	12
<b>CHECKING CONNECTIONS</b> .....	12
<b>START-UP PROCEDURE</b> .....	<b>12</b>
<i>OPERATIONAL CHECK</i> .....	13
<i>SET UP / CUSTOMISATION</i> .....	13
<i>SWITCHING OFF</i> .....	14
<b>CONFIGURATION MODES</b> .....	14
<i>ON - LINE</i> .....	14
<i>STANDBY-ON operation</i> .....	14
<i>STAND-BY OFF</i> .....	15
<i>STABILIZER (without battery)</i> .....	15
<b>MODES OF OPERATIONS</b> .....	16
<i>BATTERY operation (no in STABILIZER MODE)</i> .....	16
<i>Operation of the BY-PASS network</i> .....	16
<i>BYPASS for maintenance SWMB</i> .....	16
<b>MAINTENANCE</b> .....	<b>17</b>
<b>UPS COMPONENTS</b> .....	<b>17</b>
<i>Input / Output filter</i> .....	17
<i>Converter</i> .....	18
<i>Inverter</i> .....	18
<i>Static By-pass</i> .....	18
<i>SWMB (maintenance switch), SWIN, SWOUT</i> .....	18
<i>Battery</i> .....	18
<i>RS232 n.1 and n. 2 interface</i> .....	18
<i>Signallings and command panel</i> .....	18
<i>EPO connector (Emergency power off) normally closed contact</i> .....	18
<i>Harmonic compensator (optional)</i> .....	18
<b>SPECIFICATIONS</b> .....	<b>20</b>
<b>SYSTEM</b> .....	20
<i>CONVERTER INPUT</i> .....	20
<i>CONVERTER OUTPUT</i> .....	21
<i>BATTERY</i> .....	21
<i>OUTPUT INVERTER</i> .....	21
<i>BYPASS LINE</i> .....	21

<b>SIGNALLING PANEL FUNCTIONS.....</b>	<b>22</b>
General Description.....	22
Luminous warning lights: LED.....	22
ALARM MESSAGES.....	23
<b>CONTROL PANEL MENU .....</b>	<b>25</b>
BASIC MENU.....	25
Key menu 1, "?", HELP.....	26
Key menu 1, 1: LANGUAGES.....	27
Key menu 2 "measures".....	27
Key menu 2, 2 : "Measures output".....	28
Key menu 2, 2, 2 : measures.....	28
Key menu 2, 6: TIME MEASUREMENT.....	29
Key menu 3 "KEY", COMMANDS.....	29
Key menu 3, 2: BATTERY TEST.....	29
Key menu 3, 4: DISPLAY CONTRAST.....	30
Key menu 3, 5: CUSTOMIZING.....	30
Key menu 3, 5, 436215, 2: CUSTOMIZING RATED OUTPUT VOLTAGE.....	30
Key menu 3, 5, 436215,3: BATTERY CUSTOMIZING.....	31
Key menu 3, 5, 436215 4: PREALARM CUSTOMIZING.....	31
Key menu 3, 5, 436215 6: AUTO-OFF CUSTOMIZING "VA".....	32
Key menu 3, 5, 436215, 6, 5 (6): AUTO-OFF Timer CUSTOMIZING.....	32
Key menu 3, 5, 436215, 7, 2: BYPASS VOLTAGE RANGE CUSTOMIZING.....	33
Key menu 3, 5, 436215, 7, 3: BYPASS FREQUENCY RANGE CUSTOMIZING.....	33
Key menu 3, 5, 436215, 7, 4 : MODEM CUSTOMIZING.....	33
Key menu 3, 5, 436215, 7, 4, 5 (6) : Modem 'Dial /Send' CUSTOMIZING.....	34
Key menu 3, 5, 436215, 7, 5: RS232 CUSTOMIZING.....	34
Key menu 3, 5, 436215, 7, 6: ECHO CUSTOMIZING.....	34
Key menu 3, 5, 436215, 7, 7: IDENT. CUSTOMIZING.....	35
Key menu 3, 5, 436215, 8: CUSTOMIZING OPERATION IN STANDBY ON.....	35
Key menu 3, 5, "642137" : CUSTOMIZING OPERATION IN STANDBY OFF.....	35
Key menu 3, 5, "156234" : CUSTOMIZING STABILIZER.....	35
Key menu 3, 6: INVERTER-OFF/BYPASS.....	35
Key menu 3, 7: TOTAL SYSTEM SHUT-OFF COMMAND.....	36
Key menu 4: "RECORDER": HISTORY = RECORDED EVENTS.....	36
Key menu 4, 2 RECORDED VOLTAGES MEASUREMENT.....	36
Key menu 4, 2, 2: RECORDED CURRENT MEASUREMENT.....	36
Key menu 4, 2, 2, 2: RECORDED 3-PHASE VOLTAGE MEASUREMENT.....	37
Key menu 4, 6: RECORDED CODES.....	37
Key menu 5: Acoustic alarm exclusion.....	37
Key menu 6: "clock": DATE/TIME.....	37
Key menu 7 "arrow down": INTERNAL CODES.....	38
Key menu 8 "arrow up": NORMAL.....	38
<b>APPENDIX .....</b>	<b>39</b>
INTERNAL LAYOUT.....	39
Battery Pack Ups / Pacchi Batteria.....	41
Battery Plate Connections / Collegamenti Vassoio Batteria.....	42
<b>DIMENSION WEIGHT / DIMENSIONI PESI.....</b>	<b>43</b>

LAYOUT

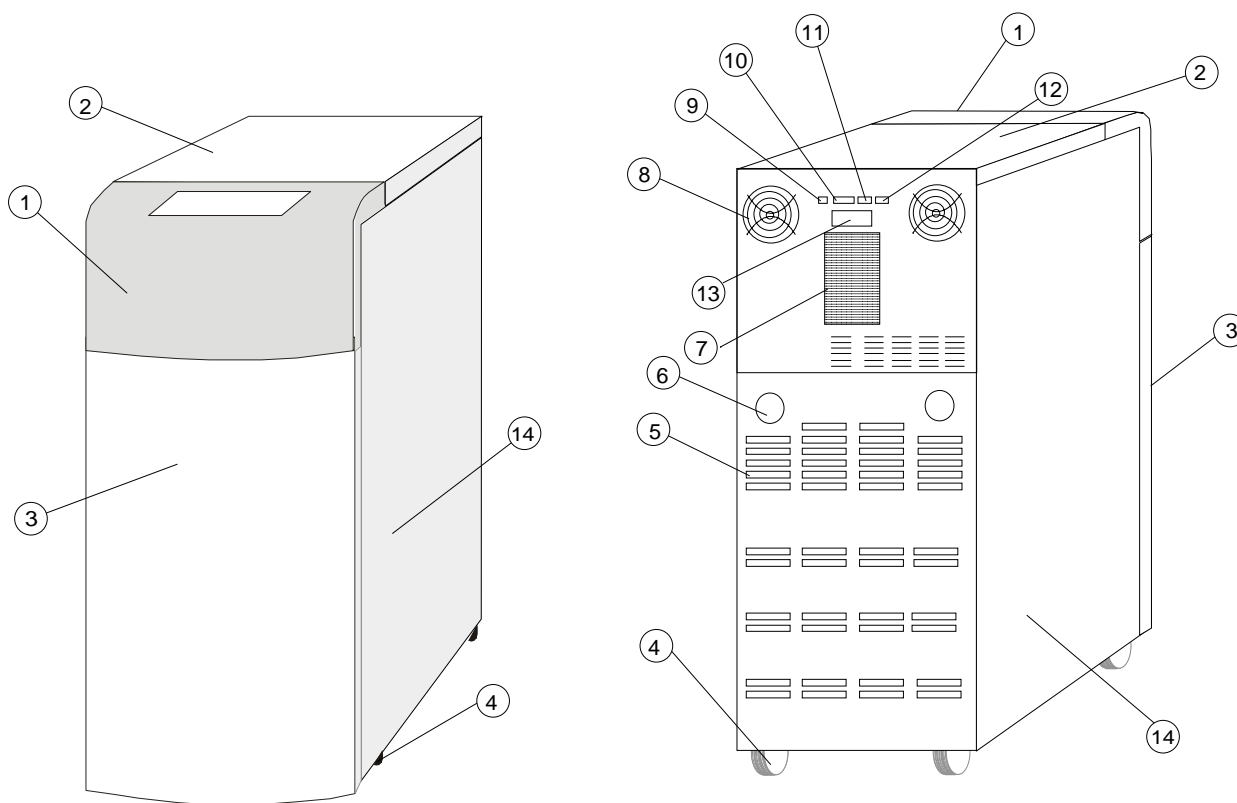

- |  |  |
|--|--|
| <ul style="list-style-type: none"> <li>1. control panel;</li> <li>2. top panel;</li> <li>3. front panel;</li> <li>4. wheels for the movement;</li> <li>5. rear ventilation holes;</li> <li>6. rear income cables;</li> <li>7. heat sinks;</li> </ul> | <ul style="list-style-type: none"> <li>8. fan grid;</li> <li>9. EPO connector;</li> <li>10. REMOTE connector;</li> <li>11. RS232-2 communications port;</li> <li>12. RS232-1 communications port;</li> <li>13. Communications-card option;</li> <li>14. Side panel;</li> </ul> |
|--|--|

STORAGE

The area used to store the equipment must have the following characteristics:

Temperature:	0°÷40°C (32°÷104°F)
Relative humidity:	95% max

**Only for UPS with internal BATTERIES.**

The batteries contained in the UPS are subject to self-discharging.

If the UPS is not immediately installed is necessary to take note of the batteries date recharge printed on the label fixed to the packing case (the date is present only if the UPS contains to its inside batteries), and provide to it recharges within such date.

To recharge batteries just power up the UPS and leave it on NORMAL OPERATION for at least 24 hours.

For advanced storage periods to contact the service assistance.

## INSTALLATION NOTE

	SINGLE PHASE OUTPUT			THREE PHASE OUTPUT			
rated power [kVA]	10	15	20	10	15	20	30
operating temperature	0 ± 40 °C						
relative humidity max.	95 % (without condensate)						
maximum operating altitude.	1000 m at rated power (-1% rated power for each 100m over 1000m), max 4000m						
dimensions (L x D x H) [mm]	450 x 750 x 1200						
UPS weight (version with harmonics reduction filter) without battery	112 (152)	122 (167)	123 (173)	114 (154)	122 (167)	124 (174)	144 (204)
7Ah	204 (244)	260 (305)		206 (246)	261 (306)		
9Ah			276 (326)			277 (327)	
12Ah	250 (290)	328 (373)	329 (379)	251 (291)	328 (373)	330 (380)	
14Ah							370 (430)
loss power with nominal load and battery charge.	0,7	1,04	1,39	0,7	1,04	1,39	2,1
[kW / kcal /B.T.U.]	600	900	1200	600	900	1200	1800
	2400	3600	4800	2400	3600	4800	7100
flow rate allowing (for room installation) (*) [mc/h]	370	557	742	370	557	742	1100
leakage current (mA) max:	< 100 mA						
Degree of protectio	IP20						
Cable input	from the bottom / rear						

(\*) To calculate the air flow rate the following formula can be used:  $Q (m^3/h) = 3.1 * p_{diss}(kcal) / (t_a - t_e) (°C)$

$p_{diss}$  is the power dissipated expressed in kcal in the installation environment by all the installed equipment.  $t_a$ =ambient temperature,  $t_e$ =outside temperature. To allow for losses the value taken should be increased by 10%. In the table in the appendix is shown an example of flowrate allowing a ( $t_a - t_e$ ) of 5°C.

## PRELIMINARY OPERATIONS

The UPS is delivered with:

- guarantee
- user instruction manual
- Cd-rom with the UPS software
- Jumper to short-circuit the input terminals (only for single-phase output version)
- Nr. 3 input battery fuse, for position see APPENDIX, INTERNAL LAYOUT pos.2 (pag. 39, pag. 40)
- Nr. 2 battery pack fuse (only if internal battery are present pag. 10)

### **INSTALLATION ROOM**

When choosing a suitable installation room, take note of the following:

- avoid dusty areas,
- check that the floor is plane level and strong enough to support the weight of the UPS and the battery cabinet (see paragraph "DIMENSIONS AND WEIGHTS")
- avoid rooms that are too narrow as this could make normal maintenance operations difficult
- relative room humidity must be lower than 95%, without condensate
- check the ambient temperature when the UPS is running. It should be between 0 and 40°C

**Z**

The UPS is able to function in an ambient temperature of between 0 and 40°C. The recommended operating temperature for the UPS and the batteries is between 20 and 25°C. In fact, the average operating life of the batteries is 4 years at an operating temperature of 20°C, but if the operating temperature is increased to 30°C the life is halved.

- do not position the machine in areas exposed to direct sun light or hot air.

In order to keep the temperature of the installation room within the field of values mentioned above, it will be necessary to install a system for eliminating dissipated heat (the value of the kcal/kW/B.T.U. dissipated by the UPS is indicated in the paragraph "SPECIFICATIONS"). The following methods can be used:

- *natural ventilation*;
- *forced ventilation*, recommended if the exterior temperature is lower (e.g. 20°C) than the temperature at which you wish to run the UPS (e.g. 25°C);
- *air conditioning system*, recommended if the exterior temperature is higher (e.g.s.30°C) than the temperature set

for running the UPS (e.g.s.25°C).

### POSITIONING

You should bear in mind the following points when positioning the UPS:

- a space of at least one metre must be kept in front of the machine to leave plenty of room for maintenance operations.
- a space of at least 20 cm. must be left between the back of the UPS and the wall so as not to block the flow of air from the fans.
- a space of at least 40 cm. must be left on the side of the UPS, for maintenance operations.

The AC-DC INPUT/OUTPUT cables may enter from the bottom or the rear of the UPS.

## SETTING UP THE ELECTRICAL SYSTEM

### PROTECTIONS

#### Inside the UPS.

The size of the switches and fuses installed on the UPS input/output lines are given below (consult the block diagrams paragraph for the initial). A fuse must always be replaced by a fuse of the same capacity and with the same characteristics as those mentioned in the table.

#### SINGLE PHASE OUTPUT UPS:

UPS type [kVA]	Switch and internal protections						
	switch		fuses			Input curr. max	Out.curr. [A] Nominal
	Input UPS	UPS output / Maintenance	Rectifier input fuse	Battery fuse	Bypass fuse		
	SWIN	SWOUT/SWMB		FBAT	FBY		
10	63A(4P)	63A (2P)	20AgR(10x38)	30A gR(10x38)	50A gG(14x51)	51	43
15	100A(4P)	100A (2P)	30AgR(10x38)	30A gR(10x38)	63A gG(22x58)	67	65
20	100A(4P)	100A (2P)	30AgR(10x38)	30A gR(10x38)	100A gG(22x58)	74	87

#### THREE PHASE OUTPUT UPS:

UPS type [kVA]	Switch and internal protections						
	switch		fuses			Input curr. max	Out.curr. [A] Nominal
	Input UPS	UPS output / Maintenance	Rectifier input fuse	Battery fuse	Bypass fuse		
	SWIN	SWOUT/SWMB		FBAT	FBY		
10	32A(4P)	32A(4P)	20AgR(10x38)	30A gR(10x38)	20A gG(10x38)	18	14
15	32A(4P)	32A(4P)	30AgR(10x38)	30A gR(10x38)	32A gG(10x38)	26	26
20	32A(4P)	32A(4P)	30AgR(10x38)	30A gR(10x38)	32A gG(10x38)	35	35
30	63A(4P)	63A(4P)	50AgR (14x51)	50A gR(14x51)	50A gG(14x51)	52	44

#### UPS Input.

When selecting the protections to install at the input of the continuity group, you must take into consideration the maximum current absorbed in the two operating conditions:

- In "NORMAL OPERATION", from the main line via the rectifier, the "max input current" is the one indicated in the table. The non automatic switch is present at the rectifier input, as shown in the table, "SWIN".
- "BY-PASS OPERATION", straight from the by-pass line, the max. value of the current is restricted by intervention of the "automatic breaker SWBY".

#### UPS output, Short circuits and selectivity.

Nominal current, In, output from the UPS is the one indicated in the table "output current".

#### Short circuit

When a fault occurs on the load, i.e. a short circuit, the UPS protects itself by restricting the value and the duration of the supplied current (short circuit current). These values also depend on the operating status of the unit at the time of the fault. We must distinguish between two situations:

- UPS in NORMAL OPERATION  
the load is immediately switched onto the by-pass line, guaranteeing, before the fuses intervene, the circuit current values indicated in "SPECIFICATION BY\_PASS LINE" paragraph.
- UPS in BATTERY OPERATION  
The UPS protects itself by supplying an output current approximately double the nominal current for 0,5s,

the output UPS is stop after this time.

**Selectivity**

In **NORMAL OPERATION** selectivity is carried out with a fuse indicated in the line two of the table, if you want to guarantee selectivity when operating by battery also see the line one of the table.

KVA	single phase output UPS						three phase output UPS							
	10		15		20		10		15		20		30	
max. current fuse gG/aM in UPS output [A]	gG	aM	gG	aM	gG	aM	gG	aM	gG	aM	gG	aM	gG	aM
1) for selectivity in battery operation	10	6	16	8	20	10	6	4	6	4	10	6	10	6
2) for selectivity in normal operation	32	16	40	20	63	36	10	6	20	10	20	10	32	16

**Differential**

In the standard version, where there is no separation transformer on the by-pass line, the neutral output from the mains is connected to the output from the UPS.

**INPUT NEUTRAL CONNECTED TO OUTPUT NEUTRAL**

**THE ELECTRICAL SYSTEMS LOCATED UPSTREAM AND DOWNSTREAM OF THE UPS ARE IDENTICAL**

When operating in the presence of mains voltage, a differential breaker installed at the input intervenes because the output circuit is not isolated from the input circuit.

In any case it is always possible to install more differential breakers at the output, possibly co-ordinated with those at the input. The differential switch located upstream must have the following characteristics:

- a minimum differential current of 100mA (to avoid inappropriate interventions)
- class A or class B
- delay greater or equal to 0,1s

**CONNECTIONS**

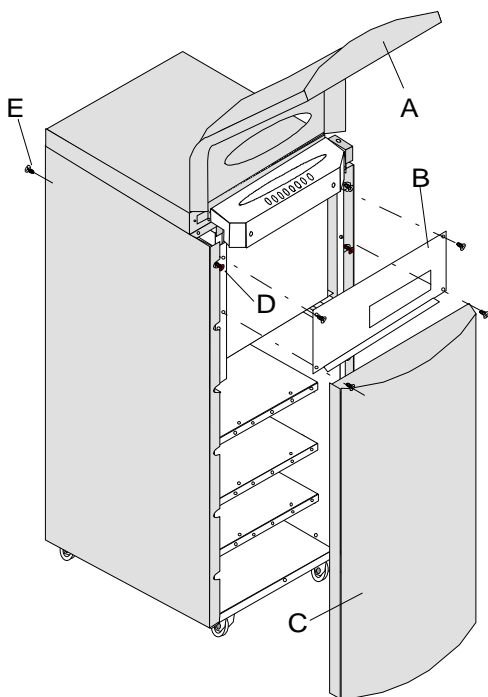

**PRELIMINARY OPERATIONS FOR OPENING UPS**

The following operations are to be performed with the UPS disconnected from the mains and all the equipment switches open (control lever down).

Following the following instructions to open the UPS:

- £ Open the covers display panel (A).
- £ Remove the covers switches panel (B)
- £ Remove the rounded front panel rising toward the high (C)

- A) covers display panel
- B) covers switches panel
- C) rounded front panel
- D-E) unscrew to remove side panels

**THE FIRST CONNECTION TO MAKE IS THE GROUNDING LEAD TO THE TERMINAL MARKED 'PE'. THE UPS CANNOT OPERATE WITHOUT CONNECTION TO THE GROUNDING SYSTEM.**



MAINS AND LOAD CONNECTIONS

**Single phase output**

input singlephase with neutral

**The UPS MUST NOT BE USED WITHOUT A INPUT NEUTRAL CONNECTION.**

Short-circuit the input Terminals, L1, L2, L3 with the jumper available, as shown in figure.

For input and output wire size refer to the following table (between brackets max. wire size):

	Sez. [mmq]			
	INPUT		OUTPUT	
kVA	L1	N	PE	L1/N
10	10(50)	10(50)	10(50)	10(50)
15	16(50)	16(50)	16(50)	16(50)
20	25(50)	25(50)	16(50)	25(50)

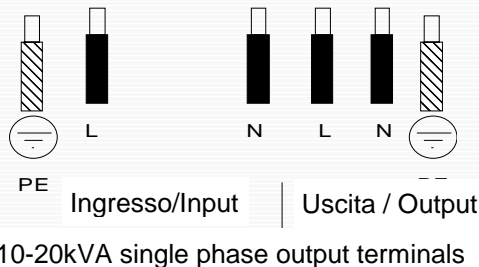
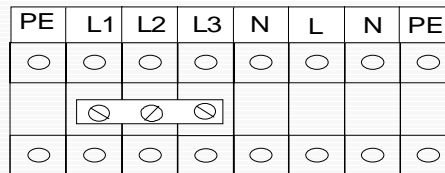

input three phase with neutral

**The UPS MUST NOT BE USED WITHOUT A INPUT NEUTRAL CONNECTION.**

For input and output wire size refer to the following table (between brackets max. wire size):

	Sez. [mmq]				
	INPUT			OUTPUT	
kVA	L1	L2/L3	N	PE	L1/N
10	10(50)	4(50)	10(50)	10(50)	10(50)
15	16(50)	6(50)	16(50)	16(50)	16(50)
20	25(50)	10(50)	25(50)	16(50)	25(50)

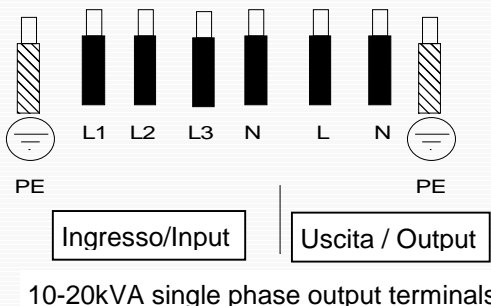
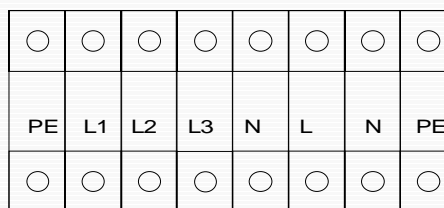

:

**Threephase output (input threephase only)**

THE UPS MUST NOT BE USED WITHOUT A INPUT NEUTRAL CONNECTION.

**10,20,30kVA**

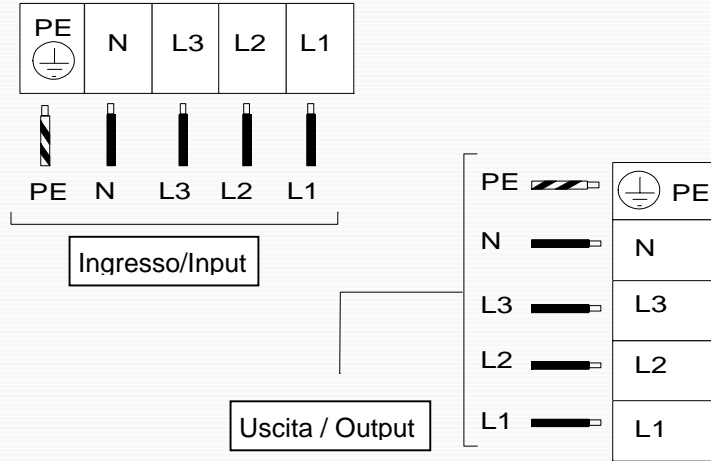

For input and output wire size refer to the following table (between brackets max. wire size):

kVA	Sez. [mmq]				
	INGRESSO		USCITA		
	L1/L2/L3	N	PE	L1/L2/L3	N
10	4 (10)	4 (10)	4 (10)	4 (10)	4 (10)
15	6 (10)	6 (10)	6 (10)	6 (10)	6 (10)
20	10 (10)	10 (10)	10 (10)	10 (10)	10 (10)
30	16(50)	16(50)	16(50)	16(50)	16(50)

- 10-20kVA threephase output terminals

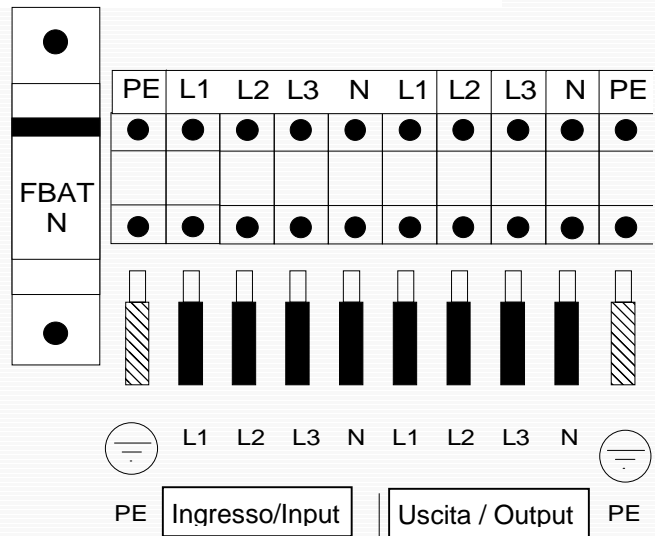

- 30kVA threephase output terminals

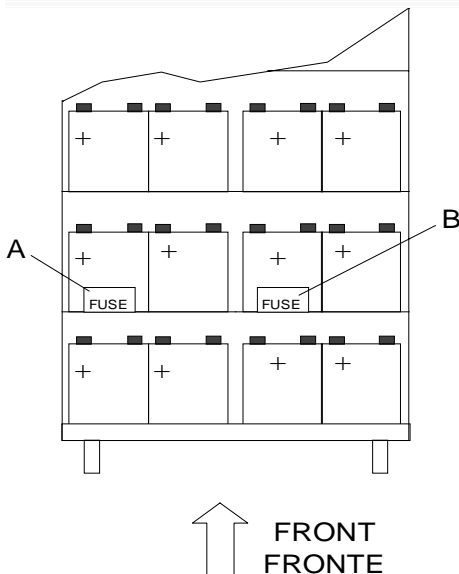

**BATTERIES CONNECTIONS**

**Internal battery cabinet**

For the versions with inner batteries, it is necessary to insert the fuse in equipment in A and B position.

**External battery cabinet**

In the external battery cabinet the batteries must be inserted and be connected, using appropriate kit in equipment, following the procedure indicated on battery cabinet user manual.

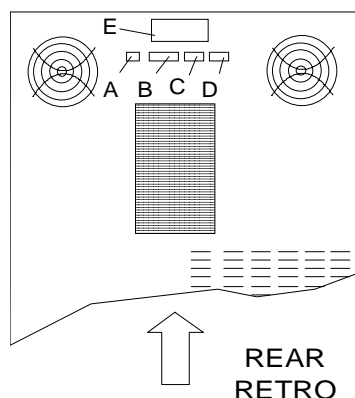

## REMOTE CONTROL AND SIGNALS

In the rear of the UPS there are the following connectors:

- pos A - EPO connector, Emergency power off;
- pos B - Nr. 1 DB15 female marked REMOTE;
- pos C - Nr. 1 DB9 male marked RS232-2;
- pos D - Nr. 1 DB9 female marked RS232-1;
- pos E - Nr. 1 SNMP connector (optional).

### **EPO connector, Emergency power off (pos. A)**

When the jumper on the EPO connector is opened the UPS output voltage is interrupted. The UPS factory supplied with the E.P.O. connectors short-circuited.

Pressing a button is therefore possible remove UPS output voltage

Removing only the feeding, for instance opening the UPS input switch, the UPS would feed the load with the batteries.

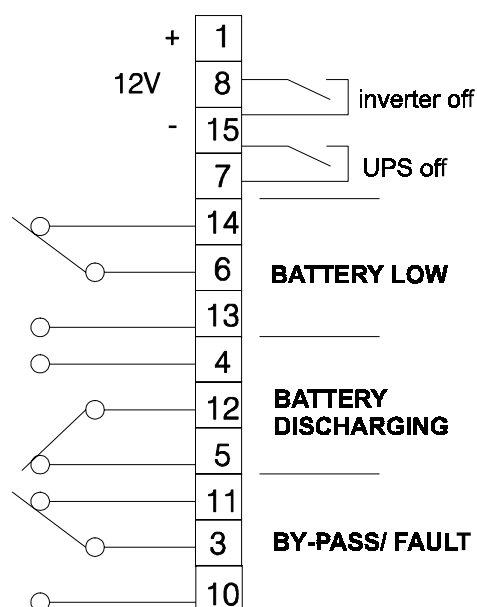

### **15-pin female marked REMOTE.**

On the connector there are:

aux power 12Vdc 80mA(max), pin 1 ad 15;

Nr. 3 voltage free exchange contacts for alarms;

Nr. 2 remote Controls for turning off INVERTER and UPS.

The pin arrangement of the connector is as follows (see figure opposite):

BATTERY LOW

BATTERY DISCHARGING

BY-PASS/FAULT

The contact positions shown are without alarm (NORMAL OPERATION).

**The relay contacts can carry a current of 0.5A-42V.**

REMOTE COMMANDS

Two commands are available as follows:

BY-PASS with STOP INVERTER command. Connecting pin 8 to pin 15 (after at least 2 seconds).

SYSTEM OFF command. Connecting pin 7 to pin 15 (after at least 2 seconds).

### **BY-PASS with STOP INVERTER ( the Command it is not memorised)**

1. If the UPS receives the INVERTER OFF command when it is in "NORMAL OPERATION" mode, it switches the load supply onto the BY-PASS line (load unprotected from any mains failure).
2. If the UPS receives the STOP INVERTER command when it is in "EMERGENCY OPERATION" mode, it will switch itself off (load not fed)

In the two versions seen, if the jumper is maintained when the mains power returns the UPS will continue operating on the by-pass line. However, if the jumper has been removed, the UPS will start up again in NORMAL OPERATION mode.

### **SYSTEM OFF (the Command is memorised).**

If the UPS receives the SYSTEM OFF command it will cut off the output voltage. LOAD NOT FEED.

To start up the UPS again, send INVERTER OFF command.

### **RS232**

Two connectors for the connection are available The transmission protocol pre-set at the UPS factory is as follows:

9600 baud, -no parity, -8bit, -1 bit of stop.

Transmission speed can be changed from 1200 to 9600 baud on the CUSTOMISE menu on the panel. Recommended transmission speeds for various distances are as follows: 9600(baud) 50m, 4800 100m, 2400 200m, 1200 300m

Use shielded cable, connect the shield only to the housing of the MODEM connector, AWG22-AWG28.

**DB9 female marked RS232-1**

To use for, pin to pin, PC connection.  
See the figure for the connections.

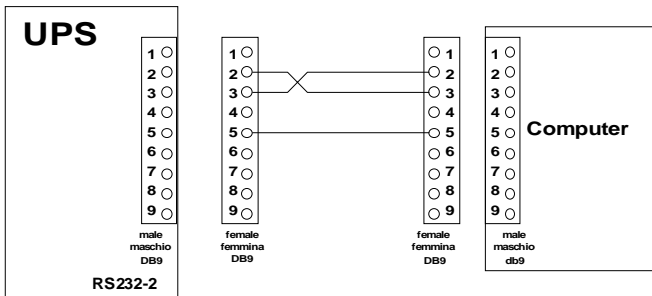
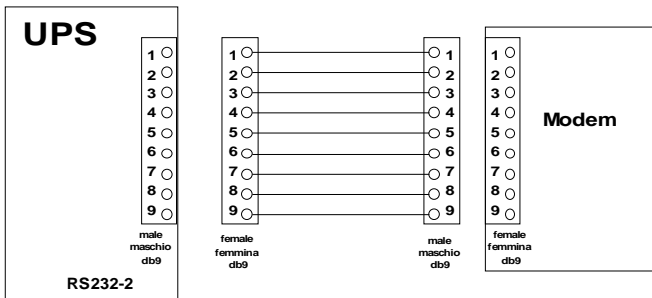
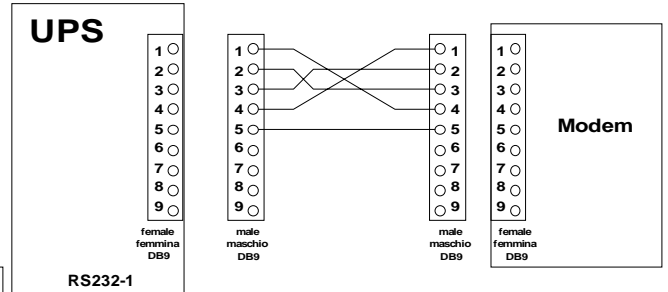
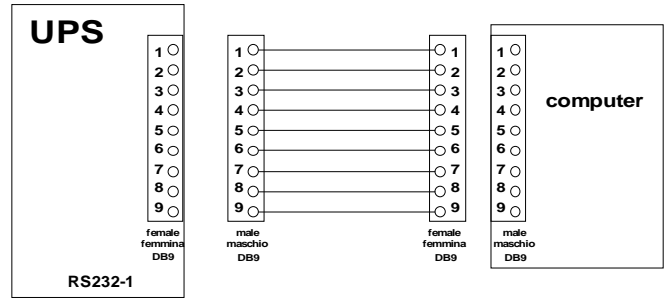

**DB9 male marked RS232-2**

To use for, pin to pin, modem connection..  
See the figure for the connections.

**SNMP connector, Simple Network Management protocol (optional)**

Lodging for the positioning of an electronic card that allows the insertion of the UPS a net SNMP (Simple Network Management protocol), with possibility to transmit data and to receive commands from a station of control that can be in an any part of the world.

**CHECKING CONNECTIONS**

After connecting the INPUT/OUT and terminal wires to the terminals of the UPS and before repositioning the switch covers panel, check to make sure that:

- all the input/output terminals are tightly screwed;
- all fuse holders have a fuse inserted and are in the closed position;
- the input/output protection wire (yellow/green earth wire) is correctly connected
- the internal panel panel is connected to the yellow/green uni-potential cable.

**START-UP PROCEDURE**

After completing the electrical connection as indicated above and putting the internal panel into position, proceed to start up the UPS as follows:

Following the following operation to start the UPS:

verify that the battery fuseholder in the UPS or in the

**Fuse and switch position of the UPS singlephase output**

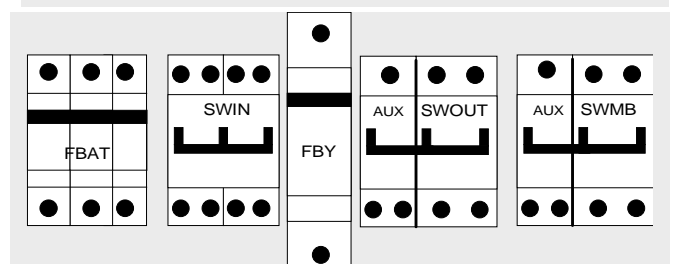

battery cabinet (if present) are closed;

verify that the harmonic filter fuseholder are closed (only if harmonic filter is present);

Close the following UPS switches (the label is given on the switch cover panel):

- FBAT battery fuses
- SWIN input switch,
- FBY by-pass line fuse (fuses for threephase version),
- SWOUT output switch.

**NOTE:** the SWMB switch must be left open, during normal operation. The SWMB is closed only in order to directly feed the mains load excluding the UPS, e.g. for maintenance purposes (see chapter OPERATING MODES).

After you have carried out the above-mentioned operations, you will immediately hear the hum of the fans, and for about one minute, the noise of the buzzer. Press button 1 twice, select the language and then press button 8, to return to the base menu. The message **NORMAL OPERATION** will appear. Carry out the battery test manually: press button 3 on the display panel, and then button 2 (BATTERY TEST). When the test is finished and the UPS is correctly started up, with the battery connected, the green IN LED (INPUT) and the green OUT LED (OUTPUT) lights should be lit without flashing. The message **NORMAL OPERATION** should appear on the first line of the panel. The model of the UPS, according to the following code, will appear on the second line in the left-hand corner:

Fuse and switch position of the UPS threephase output 10-20kVA

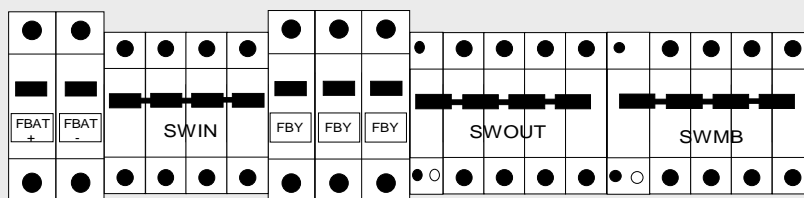
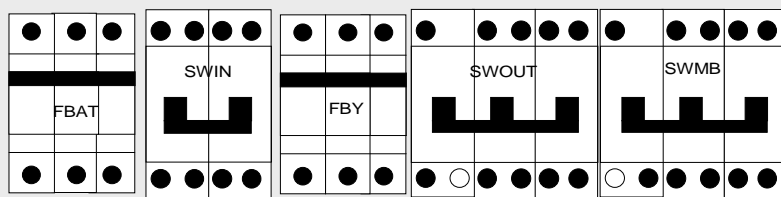

Fuse and switch position of the UPS threephase output 30kVA

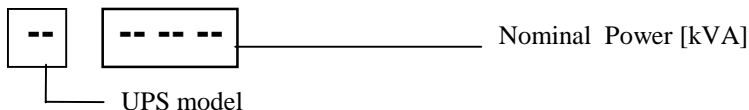
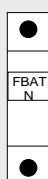

**OPERATIONAL CHECK**

After completing the start-up operations and waiting for at least four hours to allow the batteries to charge, with the UPS in normal operation, a Mains failure simulation may be carried out using the switch positioned above the continuity unit. You will hear the sound of the buzzer (with 5=ON)<sup>1</sup> while on the Signal and Commands Panel the green LED OUT .and the yellow LED are lit without flashing.

Check that the power supply to the UPS is working. In this situation, Mains power failure, the energy supplied to the load is that which has previously been accumulated in the batteries. After a few minutes with the power supplied by the batteries you can return to normal operation condition by closing the input switch. The control Panel will indicate this by turning on the green LEDs IN and OUT. The re-charging of the batteries will happen automatically.

**SET UP / CUSTOMISATION**

By inserting the access code 436215, using the COMMAND PANEL ( from the main MENU press keys 3 "COMMANDS" and then 5 " CUSTOMISING" ), it is possible modify UPS working mode (see "MODES OF OPERATION" paragraph) and alter some of the electric parameters pre-set in the factory, within a certain field:It is possible to customise the following values:

- value of the NOMINAL OUTPUT VOLTAGE;
- voltage field and the frequency of acceptance on the BY-PASS line;
- voltage field and the frequency of acceptance on the BY-PASS line in Stand-by ON mode;
- BATTERY parameters, pre-alarm for final battery discharge;
- UPS out on By-pass line when output power lower than a set value (AUTO-OFF power);
- daily scheduled shut-off (AUTO-OFF time);

<sup>1</sup> Check the status of the buzzer, in the second line on the right of the display panel:

“5=OFF” buzzer disabled,

“5=ON” buzzer enabled,

press button 5 to change the status.

- RS232-1, RS232-2 port transmission baud rate;
- identification number of the UPS.

The procedure to follow and the fields to be modified are shown in the “key menu 3,5,436215,.....” paragraph.

### SWITCHING OFF

Proceed to switching off the UPS as follows:

- open SWIN, SWOUT switches;
- open FBY, FBAT fuses holder.

The load is not fed anymore. After a few seconds the signalings panel is also extinguished

### CONFIGURATION MODES

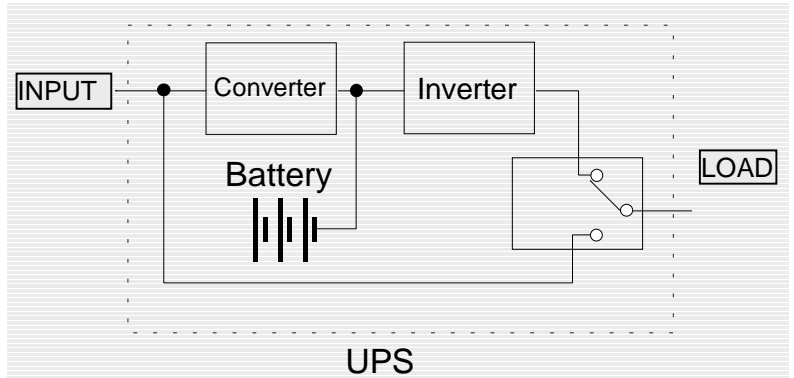

The UPS can be set in different mode of use:

Configuration mode	The LOAD is feed from:	
	with INPUT present	INPUT failure
- ON-LINE;	inverter	Inverter
- STAND-BY ON.	INPUT	Inverter
- STAND-BY OFF	not fed	Inverter
- STABILIZER	Inverter	not fed

#### ON - LINE

With the factory set, to the starter the UPS places in modality ON LINE.

Display message	INPUT	switch position		Display status					LOAD
		SWIN/FBY/ FBAT/SWOUT	SWMB	Led BATT	Led IN	Led OUT	Led BY	Buzz er	
NORMAL OPERATION	ok	close	open	off	on	on	off	off	Fed from INVERTER

MAINS present, equipment powered.

The connected equipment is powered by the inverter which receives the necessary energy from the mains through the rectifier. The RECTIFIER charges the battery at the same time.

On the control panel the green LEDS MAINS and OUTPUT are lit.



In presence of a mains power failure, the output load remains fed by the UPS that uses the energy stored in the batteries.

#### STANDBY-ON operation

With the factory set, to the starter the UPS places in modality ON LINE, in order to set up the STANDBY-ON operation modality it is necessary to read pag. 35 “CUSTOMIZING OPERATION IN STANDBY ON”.

*STANDBY-ON operation permits a reduction in the energy lost by the system. Before using this function check that the fed load accepts an interruption of 2-5 ms. in feed, in the event of a mains power failure.*

On the in the second line of the display panel N letter is present.

Display message	INPUT	switch position		Display panel status					LOAD
		SWIN/FBY/ FBAT/SWOUT	SWMB	Led BATT	Led IN	Led OUT	Led BY	Buzz er	
NORMAL OPERATION STBY-ON	ok	close	open	off	on	on	off	off	Fed from INPUT
MAIN LINE VOLTAGE FAIL or SWIN OFF	ko	close	open	on	off	on	off	on	Fed from INVERTER

The RECTIFIER remains turned on and maintains the battery charge.

The inverter to by-pass line transfer can be immediate (planned time =0) or delayed (maximum of 180 minutes), see menu 'CUSTOMIZING OPERATION IN STANDBY ON' (N.B. because the passage happens it is necessary that the line of bypass remains within the values of acceptance for the planned time).

The System remains in this state until voltage and frequency of the BY-PASS line are within acceptable limits.

**Z** *If the BY-PASS line lacks voltage or the frequency goes outside acceptable limits, the load is switched automatically to the INVERTER output.*

**advantages and disadvantages of the two ways of operation (ON LINE or STAND-BY ON):**

	advantages	disadvantages
comparison between ON-LINE and STAND-BY ON mode	<ul style="list-style-type: none"> <li>- inverter always feeds load with voltage and frequency stabilized,</li> <li>- transfer time to battery operation equal zero,</li> <li>- power factor corrector to the main line</li> </ul>	<ul style="list-style-type: none"> <li>- power lost, UPS efficiency with nominal load is 92÷93%,</li> </ul>
comparison between STAND-BY ON and ON-LINE mode	<ul style="list-style-type: none"> <li>- reduced power lost, UPS efficiency with INPUT present is 98%.</li> </ul>	<ul style="list-style-type: none"> <li>- Load is feed from mains voltage and frequency,</li> <li>- transfer time to battery operation not equal zero</li> </ul>

**STAND-BY OFF**

With the factory set, to the starter the UPS places in modality ON LINE, in order to set up the STANDBY-OFF operation modality it is necessary to read pag. 35 "CUSTOMIZING OPERATION IN STANDBY OFF".

*With UPS in STAND BY OFF mode and mains input is present the UPS voltage output is equal to zero. The output load is feed only when input voltage is failure.*

On the in the second line of the display panel F letter is present.

Display message	INPUT	switch position		Display panel status					LOAD
		SWIN/FBY/FBAT/SWOUT	SWMB	Led BATT	Led IN	Led OUT	Led BY	Buzzer	
<b>NORMAL OPERATION STBY-OFF</b>	ok	close	open	off	on	off	off	off	Not fed
<b>MAIN LINE VOLTAGE FAIL or SWIN OFF</b>	ko	close	open	on	off	on	off	on	Fed from INVERTER

The RECTIFIER remains turned on and maintains the battery charge.

The UPS output voltage is equal to 0V until voltage and frequency of the BY-PASS line are within acceptable limits.

**Z** *If the BY-PASS line lacks voltage or the frequency goes outside acceptable limits, the load is feed automatically to the INVERTER output.*

**STABILIZER (without battery)**

With the factory set, to the starter the UPS places in modality ON LINE, in order to set up the STANDBY-OFF operation modality it is necessary to read pag. 35 "CUSTOMIZING STABILIZER".

On the in the second line of the display panel S letter is present.

Display message	INPUT	switch position		Display panel status					LOAD
		SWIN/FBY/FBAT/SWOUT	SWMB	Led BATT	Led IN	Led OUT	Led BY	Buzzer	
<b>NORMAL OPERATION</b>	ok	close	open	off	on	on	off	off	Fed from INVERTER

MAINS present, equipment powered.

The connected LOAD is powered by the inverter which receives the necessary energy from the mains through the rectifier.

The batteries are not present.

**Z** In presence of a mains power failure, the output load remains not fed.

## MODES OF OPERATIONS

- BATTERY OPERATION (no in STABILIZER MODE)
- Operation of the BY-PASS network;
- BYPASS for maintenance SWMB;

### **BATTERY operation (no in STABILIZER MODE)**

Display message	INPUT	switch position		Display panel status					LOAD
		SWIN/FBY/ FBAT/SWOUT	SWMB	Led BATT	Led IN	Led OUT	Led BY	Buzz er	
MAIN LINE VOLTAGE FAIL or SWIN OFF	ko	close	open	on	off	on	off	on	Fed from INVERTER

MAINS off, equipment powered.

The UPS is in this operating condition when MAINS power is lacking in a black out or is no longer in an acceptable range (over or under voltage).

In this phase of operation the energy required by the connected equipment is supplied by the battery, previously charged.

On the alphanumeric PANEL on the front of the UPS is displayed the time provided for residual AUTONOMY, calculated on the basis of the power delivered and the charge status of the batteries.

NOTE. The value displayed is approximate since the power required can change during discharge.

### **IT IS POSSIBLE TO INCREASE DURATION BY DISCONNECTING SOME OF THE CONNECTED EQUIPMENT.**

The green LEDs for OUTPUT (steady light) are lit on the panel and the yellow LED for the battery (STEADY LIGHT) at the moment of mains failure sounds the buzzer intermittently.

When the remaining time drops below the preset value as LOW BATTERY alarm, the buzzer increases in frequency while the yellow BATTERY LED goes to flashing. Under this condition it is wise to save any work under way. When the mains failure continues and the battery exhausts its energy, the UPS cuts off power to the loads.



*Upon return of mains power, the UPS recharges the batteries automatically.*

### **Operation of the BY-PASS network**

*Temporary State of operation, or permanent operation state caused by a breakdown; in this last case contact the assistance centre.*

*The load isn't secured in case of mains failure.*

Display message	INPUT	switch position		Display panel status					LOAD
		SWIN/FBY/ FBAT/SWOUT	SWMB	Led BATT	Led IN	Led OUT	Led BY	Buzz er	
<b>BYPASS FOR OUTPUT OVERLOAD</b>	ok	close	open	off	on	off	On or blink	on	Fed from bypass

MAINS present, load fed.

The UPS can find itself in this condition due to one of the following events:

- BY-PASS command (manual or automatic)
- excessive load in output (overload, see the paragraph ALARM MESSAGES)
- fault

On the control panel, the green INVERTER output LED is off, the yellow BY-PASS LED will be turned on steady if a command is present but will flash on and off in the presence of an overload or fault.

In case of a load greater than the nominal (overload) you will have to intervene to reduce it, otherwise the fuse on the by-pass line will intervene, turning off the output (for times of intervention consult the SPECIFICATIONS paragraph).

### **BYPASS for maintenance SWMB**

Series of operations to be carried out to place the UPS in maintenance by-pass to carry out maintenance operations on equipment while maintaining the fed load:



**Status I**

NORMAL OPERATION

**Status II**

SWMB switch closed (the control logic automatically disables the inverter).

**Status III**

All machine switches open. Only the SWMB switch is kept closed (by-pass maintenance line). The signal panel remains off. With the load powered through the maintenance line (during maintenance) any disturbance such as a blackout on the power line of the UPS would have repercussions on the powered equipment (under this condition the operation batteries are deactivated).

**When the maintenance operations are concluded restart the UPS: close SWIN, SWBY, SWOUT and then open SWMB. The UPS will return to NORMAL OPERATION.**

## MAINTENANCE

**CAUTION** Maintenance inside the UPS should only be done by qualified personnel. Inside the equipment there are voltages even with the input and battery switches open. Removal of the side panels of the UPS by unqualified personnel can cause harm to the operator and damage the equipment.

**Preventive Maintenance**

The only components of the UPS which require periodic checking are the blowers and batteries.

- **Blowers** should be checked for correct operation periodically.

- **Batteries.** **CAUTION** Any battery replacement should be done by qualified personnel. For disposal of the replaced parts it is obligatory to deliver them to one of the special consortiums for disposal by recycling. Batteries are classified 'toxic waste' by law. The system automatically checks battery efficiency every 24 hours and gives an alarm when it finds efficiency very much lower than that calculated on the basis of memorized capacity (see key menu 3.2 BATTERY TEST). Battery life depends on operating temperature and the number of charging and discharging cycles performed. Battery life when used at 20°C is approximately 3 to 5 years while duration is halved if operating temperature goes to 30°C. Capacity is not constant but increases after a few charging and discharging cycles, then remains constant for several hundred cycles and finally decreases.

Battery maintenance should include: - Holding operating temperature in the range 20-25°C.

- During the first month of use carry out two or three charge/discharge cycles.

- After the first month of use perform this operation every six months.

The battery should be changed if necessary only by qualified personnel. To eliminate replaced parts it is obligatory to deliver them to one of the special consortiums for disposal by recycling. The batteries are classified toxic waste by law.

## UPS COMPONENTS

The UPS consists of the following subassemblies:

- input /output filter (EMI);
- converter;
- inverter;
- by-pass;
- SWMB (maintenance switch), SWIN, SWOUT;
- Battery;
- RS232-1, RS232-2;
- Remote control and signals;
- Signallings and command panel;
- EPO (Emergency Power OFF);
- Harmonic compensator (optional)

**Input / Output filter**

They eliminate the high frequency disturbance, during the normal operation, protecting the UPS and therefore the uses connected by the deriving troubles by supply network. They avoid besides that the high frequency present inside the UPS is propagated to the outside.

In the threephase versions is place on the input/output terminal board while in the singlephase versions is positioned after the input switch.

In Stand-By On operation, and in " Bypass " the filters always furnish the protection of the uses from the troubles of by supply network. In the threephase versions the protection is also guaranteed in the condition of Maintenance by-pass (SWMB close).

### **Converter**

Represents the input stage and transforms the alternating voltage of the power line in continuous voltage.

In Normal Operation it feeds the inverter and charge the battery.

During the input voltage fault it raises battery output voltage to the constant value required by the inverter.

In the singlephase UPS version the converter can indifferently be connected singlephase to a line 230V or threephase 400V with neutral.

The converter is behaved as an PFC (power factor control) the input power factor is very high (0,99 with singlephase input, 0,95 with threephase input), the UPS is behaved as an power factor corrector with benefits effects on the plant.

### **Inverter**

This is the output stage. Converts direct voltage from the RECTIFIER or BATTERY into stabilized sinusoidal alternating voltage. In "ON LINE " mode it is always in operation and the load connected to the output of the UPS is always powered by the INVERTER.

### **Static By-pass**

This device allows the instantaneous automatic or manual switching of the power feed from the secured line (INVERTER output ) to an unsecured line (BY-PASS line) or vice versa is realised with SCR that assure the commutation in time zero. It is able to sustain intolerable overloads for the electronics of the inverter and to also allow the continuity of the tension exit of the UPS in case of breakdown inside of the same.

In series to the SCRs the protection is inserted against the returns of tension ("back-feed, protection"), to prevent that in the case of breakdown of the SCRs, there is, during the interruption of the primary feeding, a potential with danger of electric shake to the clamps of feeding.

To the entry of the line of bypass they are present the fuse FBYs (one in the version singlephase, three in the version threephase), such fuses protect both the SCRs in the case of short circuit in exit is the line of bypass from prolonged overloads.

### **SWMB (maintenance switch), SWIN, SWOUT**

Maintenance switch, by closing the SWMB and opening the other switches SWIN, SWBY, SWOUT the UPS is excluded, maintaining the output feed.

This operation is necessary when you have to carry out maintenance operations inside the equipment, without being obliged to interrupt the power feed.

With the SWMB closed and all the other switches open, there is no voltage inside the equipment (voltages are present only in the terminal board area, in the switches area and in input/output filter area in the threephase version).

### **Battery**

Provides the reserve energy for powering the load when there is no power input to the UPS.

The batteries can be lodged into the UPS or, for longer autonomies, in separate battery cabinet.

### **RS232 n.1 and n. 2 interface**

On the UPS (standard version) are present two RS232 DB9 type connector (one male and one female) and one DB15 female for remote control and signals.

### **Signallings and command panel**

Signalling of operational status of the UPS is supplied by:

- a liquid crystal display (LCD) with two lines of 40 characters
- one keyboard with eight keys,
- four warning lights
- an audible signal.

### **EPO connector (Emergency power off) normally closed contact**

When the jumper on the EPO connector is opened the UPS output voltage is interrupted. The UPS factory supplied with the E.P.O. connectors short-circuited.

### **Harmonic compensator (optional)**

The filter is positioned to the entry of the converter, allows to reduce the input harmonic distortion of the current. It's made only for threephase input version. The filter is protected in entry with fuses.

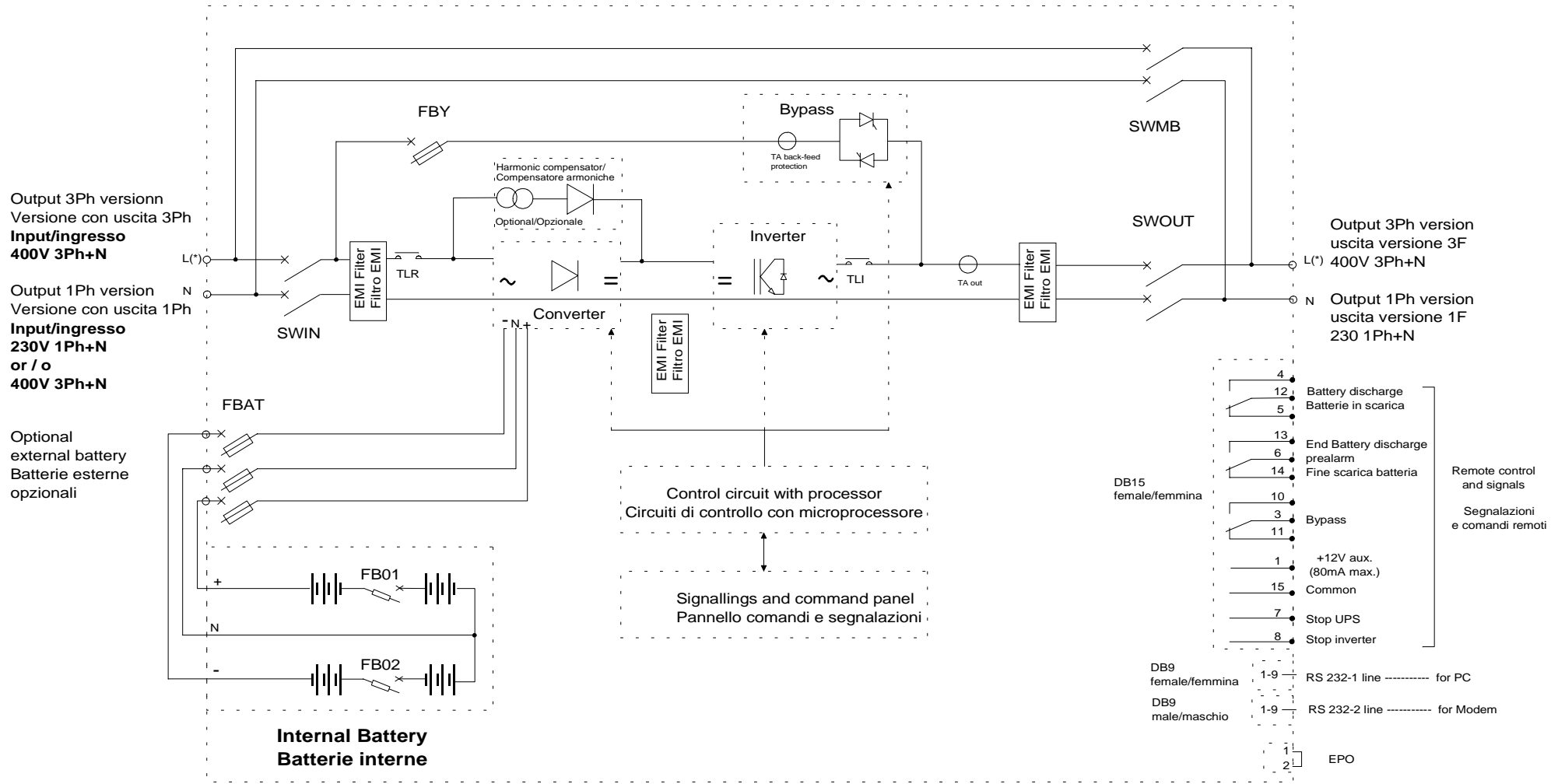

L1,L2,L3 In the threephase version / nella versione trifase L1,L2,L3.

## SPECIFICATIONS

### SYSTEM

	SINGLEPHASE OUTPUT			THREEPHASE OUTPUT			
rated power [kVA]	10	15	20	10	15	20	30
rated voltage	400V 3F+N o 230V 1F			400V 3F+N			
output power [kVA]	10	15	20	10	15	20	30
output active power [kW]							
singlephase input	8	10,5	12				
threephase input	8	12	16	8	12	16	24
output power function minimum input voltage	100% output power with input voltage -20% 60% output power with input voltage -30% 40% output power with input voltage -40%						
efficiency (STANDBY-ON) load 0÷100%	98%						
efficiency nominal load "ON LINE"							
100% load	93			92			
50% load	91			90			
leakage current (mA) max:	< 100 mA						
remote signalling	three voltage free exchange contacts (battery low, battery discharging, by-pass/fault), output 12V dc 80mA						
remote command	By-pass and SYSTEM OFF						
emergency off	EPO						
computer/modem interface	Nr 2 RS232/C						
SNMP interface	optional						
operating temperature	0 ± 40 °C						
relative humidity max.	95 % (without condensate)						
maximum operating altitude	1000 m at rated power (-1% rated power for each 100m over 1000m), max 4000m						
cooling	Forced ventilation (fan speed function of the load)						
acoustic noise, as measured at 1m from front of equipment (depend on load and temperature) [dBA]	50÷56						
protection degree	IP20						
cable input	Bottom / rear						
applicable standards	Safety EN 50091-1-1, Electromagnetic Compatibility EMC EN 50091-2 Liv.A						
standard	SCR BACKFEED PROTECTION						

### CONVERTER INPUT

	SINGLEPHASE OUTPUT			THREEPHASE OUTPUT			
rated power (kVA)	10	15	20	10	15	20	30
rated voltage	± 20 % at nominal load						
Input frequency	50 / 60 Hz auto learning						
frequency tolerance	45 ÷ 65						
Max input current with min voltage (with nominal load) [A]:							
threephase input	18	26	35	18	26	35	50
singlephase input	51	67	74				
current distortion	27 % threephase input / 7 % singlephase input						
power factor	0,95 threephase input, 0,99 singlephase input						
UPS with harmonic filter	Input threephase only						
current distortion	9%						
power factor	0,99						

**CONVERTER OUTPUT**

	SINGLEPHASE OUTPUT			THREEPHASE OUTPUT			
	10	15	20	10	15	20	30
maintenance voltage (20°C, 2,26 x el) [V]	-217+217	-325+325		-217+217	-325+325		
charge voltage (2,3 x el) [V]	-221+221	-331+331		-221+221	-331+331		
max output voltage [V]	-222,5+222,5	-334+334		-222,5+222,5	-334+334		
ripple voltage [V]	< 1%						
max charge voltage [V]	-222,5+222,5	-334+334		-222,5+222,5	-334+334		
max charge current with nominal load [A]	1,5						4

**BATTERY**

	SINGLEPHASE OUTPUT			THREEPHASE OUTPUT			
	10	15	20	10	15	20	30
type	Lead sealed battery						
element number (12V each element)	16+16	24+24		16+16	24+24		
total rated voltage [V]	-192+192	-288+288		-192+192	-288+288		

**OUTPUT INVERTER**

	SINGLEPHASE OUTPUT			THREEPHASE OUTPUT			
	10	15	20	10	15	20	30
rated power [kVA]	10	15	20	10	15	20	30
active power [kW]							
threephase input	8	12	16	8	12	16	24
singlephase input	8	10,5	12				
rated voltage [V]	230			400			
rated current [A]	43	65	87	14	22	29	43
phase voltage setting (phase-neutral)	200 ÷ 250 V , phase neutral (control panel)						
load crest factor at rated power (I <sub>peak</sub> /I <sub>rms</sub> )	3 : 1						
wave form	Sinusoidal						
distortion with linear load	2 %						
stability voltage at steady state	± 1 %						
stability voltage at transient state	± 5 %						
frequency stability: with synchronisation	±2 % ( settable ± 1 % , ± 5% control panel)						
without synchronisation	± 0,05 %						
overload	110 / 125 / 150 % rated current 300' / 10' / 1'						
short circuit current for 0,5s	200%						
Inverter efficiency % 100% load	94			93			

**BYPASS LINE**

	SINGLEPHASE OUTPUT			THREEPHASE OUTPUT			
	10	15	20	10	15	20	30
rated power [kVA]	10	15	20	10	15	20	30
rated current [A]	43	65	87	14	22	29	43
rated voltage [V]	230			400			
Number of phase	1+N			3 + N			
input voltage tolerance	±15 % ( settable ± 5 % , ± 25 % control panel)						
rated frequency	50 / 60 Hz (auto learning )						
input frequency tolerance	±2 % ( settable ± 5 % control panel)						
stand-by on/inverter typical transfer switch time	2 ms						
overload/fault inverter transfer switch time	0 ms / 1ms						
by-pass fuse type	50 / gG	63 / gG	100 / gG	20 / gG	32 / gG	32 / gG	50/gG
by-pass line overload capacity (x nominal current)							
1h	1,6	1,4	1,7	2,5	2,3	1,7	1,6
10min.	1,8	1,6	1,9	2,7	2,8	2	1,8
1min	2,8	2,6	2,9	3	3,4	2,6	2,8
1s	5,1	5,4	7,4	5,7	7,7	5,8	5,1
10ms	20	20	28	28	32	24	20

## SIGNALLING PANEL FUNCTIONS

### GENERAL DESCRIPTION

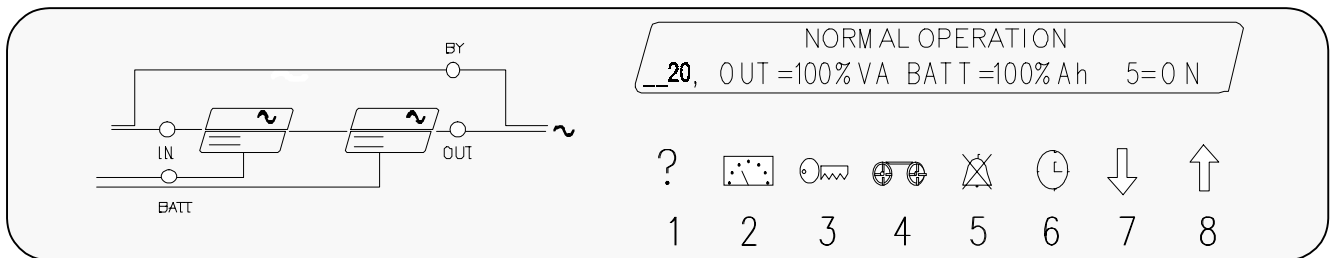

Signalling of operational status of the UPS is supplied by:

- a liquid crystal display (LCD) with two lines of 40 characters
- four warning lights:
 

IN	Power & bypass input lines
OUT	Bypass line output
BY	Bypass line output
BATT	Battery input.
- an audible signal.

#### **Luminous warning lights: LED.**

LED warning lights supply quick information directly onto the control panel of the system. They may be steady, flashing or turned off.

☺ LED IN (green): input lines

The luminous LED signal IN means:

- lit when the input power and bypass voltages are present and correct
- flashing when one of the two voltages is not correct
- extinguished when both the voltages are neither present nor correct.

☺ LED OUT (green): inverter output line

The luminous LED signal IN means:

- lit when the system output is switched to the inverter, the output power is correct because less than 100% VA and only the output switch SWOUT is closed
- flashing when the system output is switched to inverter the output power is greater than 100% VA, or SWMB is closed also
- extinguished when the system output is switched to automatic bypass line or SWOUT is open

☺ LED BY. (yellow): automatic inverter output line

The luminous LED signal BY. is:

- lit when the system output is switched to the automatic bypass line
- flashing when the system output is switched to the automatic bypass line with output power greater than 100% VA, or the manual bypass switch SWMB is closed
- extinguished when the system output is switched to inverter, or is active SYSTEM OFF command

☺ LED BATT (yellow): battery line

The luminous LED signal BATT is:

- lit when the battery is delivering
- flashing when the alarm PREALARM, LOW BATTERY VOLTAGE is active or the alarm BATTERY DISCHARGED OR SWB OPEN is active
- extinguished when the battery is not delivering and its voltage is correct.

#### Acoustic Signal

The acoustic signal sounds intermittently and pauses for about 2 seconds under all conditions different from normal operation, i.e. different from the condition in which only the two green LED signals IN and OUT are lit.

The sound is intermittent without break when the LED BATT is flashing.

The acoustic signal never operates if it has been excluded with key 5, also it does not operate when the system was stopped by the AUTO-OFF function.

Its enablement status is visible in the basic menu: 5=ON indicates enablement and 5=OFF indicates exclusion.

Exclusion with key 5 is possible in all menus where the same key is not used for other functions.

Enablement is possible only in the basic menu.

Under normal operating conditions, without special requests for information or entry of commands with the keys or from the RS232 remote line, the LCD viewer shows basic messages referred to even with the basic menu or menu 0 or NORMAL menu names. It is possible to obtain other information or enter commands, acceding to submenus by pressing keys from 1 to 8 with appropriate sequences. With each key pressed there is a brief sound while the change of messages takes place only when an enabled key is pressed. Key functions in the menu 0 are suggested by the symbols associated while in other submenus they are indicated explicitly by the message. For some particular functions it is necessary to refer to the manual. Return to menu 0, in addition to being possible by pressing keys, takes place automatically also two minutes after the last pressing of a key.

## ALARM MESSAGES

A list is given below of the alarm messages displayed on the first line of the display panel, the alarm number in brackets shows the priority level.

### **[1] DISTURBANCES ON BYPASS LINE**

Alarm present when there are disturbances on the bypass line of the voltage peaks or harmonic distortions type, while voltage and frequency are correct. CAUTION. In this case the inverter is not synchronised with the bypass line, hence if the bypass is forced with the switch SWMB or the remote controls or panel there could be wrong switching between voltages in counterphase.

### **[2] BY-PASS MANUAL, SWMB - ON or cable defect**

Manual BY-PASS SWMB Switch inserted and therefore return to normal operation is prevented. Load is fed by the input of the BY-PASS line and therefore isn't secured by the continuity unit. "cable defect" only for UPS in parallel version, logic has revealed an error in signals exchanged between the UPSs connected in parallel, and has therefore switched the entire system to BY-PASS.

### **[3] BYPASS VOLT. FAIL or SWIN, FBY OFF**

Alarm is present if:

- bypass line input voltage is wrong,
- input line turn-on switch SWIN is open,
- FBY fuse by-pass line open.

### **[4] MAIN LINE VOLTAGE FAIL or SWIN OFF**

Input voltage is wrong and battery is discharging.

The alarm appears if:

- input voltage or frequency are without range ,
- SWIN power switch is open,
- the rectifier does not recognize the voltage due to internal anomaly;

### **[5] PREALARM, LOW VOLTAGE ON BATTERY**

The alarm is present if:

- the battery voltage is lower than calculated to supply approximately 5 minutes duration or the residual ;
- autonomy time is lower than the time set for the prealarm.

### **[6] BATTERY DISCHARGED OR FBAT OPEN**

The logic of the UPS has carried out A BATTERY TEST, during presence of mains feeding, the voltage of the battery was lower than the estimated value (see menu 3,2 BATTERY TEST).

### **[7] LOW VOLT. SUPPLY or OVERLOAD [W]**

This alarm is present if one of the following conditions is verified:

- voltage of feeding in input is insufficient to feed load, (see general characteristics);
- load of output, in active power W, is higher than the nominal value .

**[8] OUTPUT OVERLOAD**

Indicates that the power absorbed by the load at the output is greater than allowed rated power, hence the indicated value expressed in %VA exceeds 100%. The same alarm is activated also when the peak absorbed current of the load exceeds the maximum admitted. When this alarm is on it is necessary to reduce the load, otherwise the system automatically goes on bypass within a time period inversely proportional to the amount of the overload.

**[9] BY-PASS FOR VA OUTPUT < AUTO-OFF VALUE**

This alarm is present when power in %VA, absorbed by the load is lower than the set value of " AUTO-OFF" (see menu' 3,5,6 CUSTOMISING . AUTO-OFF " VA").The value of %VA for AUTO-OFF is set to 0 in the factory (therefore this alarm condition can't happen).

**[10] INTERNAL FAULT: number**

The number indicates the different causes of fault:

- INTERNAL FAULT 1. Precharge starting fail
- INTERNAL FAULT 2. Inverter permanent fault.
- INTERNAL FAULT 3. Inverter output line contactor fault.
- INTERNAL FAULT 4. Booster output voltage fail
- INTERNAL FAULT 5. By-pass SCR ON or OFF fail.
- INTERNAL FAULT 6. -----
- INTERNAL FAULT 7. A voltage feeding the system control card is not correct.
- INTERNAL FAULT 8. High voltage on battery charger
- INTERNAL FAULT 9. Battery SCR fail
- INTERNAL FAULT 10. -----
- INTERNAL FAULT 11. Fail switching load on inverter

**[11] TEMPORARY BYPASS, WAIT**

Indicates that the load is powered by the bypass line and the system is in the previous phase of automatic return to normal operation powered from the inverter. This transitory operation occurs e.g. during the starting phase of waiting for return on inverter after bypass for overload.

**[12] BY-PASS FOR OUTPUT OVERLOAD (displayed steady or flashing) flashing display ALARM MEMORISED**

It shows that the overload condition of the BY-PASS line has been memorised.

In order to be memorised the overload has to remain for a certain time. Some situations are shown here:

150% for 10', 175% for 1' or 150% for 18".

In versions with power <100KVA the load remains fed by the BY-PASS line, if no one intervenes to reduce the load, until the intervention of the thermal-magnetic guard of the SWBY switch in input.

In versions with power 100kVA or greater in this alarm condition the load remains without power.

After reducing the load, to remove the memory, to return to the " NORMAL OPERATION ", it is necessary carry out the following procedure: close SWMB, open SWBY then close SWBY and open SWMB.

**steady display**

It shows that the load is fed by the BY-PASS line and is over the nominal value, the alarm has not yet been memorised, the value shown on the panel, expressed in percentages %VA, is over 100%.

To return to the NORMAL OPERATION situation **before** the memorising, reduce the load and wait a few minutes to allow cooling (e.g. time to return to NORMAL OPERATION is 60s if the load reduces to 50%, and 8 minutes if the load reduces to 75%).

**[13] BYPASS COMMAND ACTIVE; 8=COMMAND OFF**

The system has been deactivated and switched to bypass by a special command entered with the keyboard. The command does not remain in the memory after a shutdown due the end of battery discharging.

In that case, upon return of power the system returns to normal operation also if the intentional lockup were not deactivated.

**[14] REMOTE BYPASS CONTROL: ACTIVE**

The system has been deactivated and switched to bypass by special command applied to the connector 'remote controls and signals'. The command is not memorised and the system returns to normal operation when the command is cancelled provided power voltage is present.

**[15] OVERTEMPERATURE or FAN FAILURE**



Internal temperature on the system card, power modules of the inverter or on the power modules of the rectifier or on the output transformer have exceeded the maximum allowed as a result of operation in an environment with excessive heat or failure of the fans.

**[17] INPUT VOLTAGE SEQUENCE NOT OK**

Input phase sequences of the bypass line is not correct. Normally it is sufficient to reverse two phase to obtain normal operation.

**[18] OUTPUT OFF, CLOSE SWOUT OR SWMB.**

Output voltage is absent because both switches SWOUT and SWMB are open.

**[19] SYSTEM OFF COMMAND ACTIVE ; 8=DISACTIVE.**

Alarm present when total shut-down command has been inserted from the panel or through the RS232 connection, **COMMAND MEMORISED.**

The System carries out the shut-down command with a few seconds of delay to allow for possible cancellations.

The command remains memorised also during a shut-down due to lack of feeding.

When the feed returns, the system does not return to normal operation mode unless the deliberately SYSTEM OFF is disactivated. To disactivate it, close SWBY or, if required, press 8.

**[20] SYSTEM OFF COMMAND ACTIVE; 8=COMMAND OFF.**

Like previous alarm, with present command from REMOTE connector

**[21] MEMORY CHANGED: CODE = number**

**Number** shows the different cases.

**Code 1** memory has been changed and the operation parameters have been set to standard values.

If previously non-standard values have been set it is necessary to carry out a new customising of these values.

To remove alarm from the display turn off then turn on

NOTE: codes different from 1 can only appear temporarily. During variations of customising they do not influence normal operation.

**[22] AUTO-OFF Timer: T off= 0: 0', T on 0: 0'**

The alarm appears when the internal daily timer is operating for a daily cycle of system self-starting and self-stopping (see menu CUSTOMISING).

This timer cycle is inhibited if Toff and Ton value are equal.

## CONTROL PANEL MENU

### BASIC MENU

o=__	NORMAL OPERATION
__20,	OUT=100%VA, BATT= 100%Ah, =ON

In the basic menu the upper line presents a signalling message to describe the present status while the lower line indicates model, apparent power measurement by percentage output by the inverter or bypass line, charging status of the battery or time expected for duration of battery.

The viewer permits display of a single phrase at a time, hence a priority is established according to which the most important message is displayed, while other information is entrusted to the interpretation of the internal codes.

Under all operating conditions, after two minutes from the last command with the keys, the viewer returns to BASIC MENU in which are presented the signalling messages for operating status.

o=\_\_ this value is present alone after the insertion of one of the following codes, for the formality of insertion to consult the following paragraphs

o=X. 1-3-5-7-9-B-D-F	--
o=X. -23--67--AB--EF	Active the auto off for Timer off
o=X. ---4567----CDEF	Active the auto off for low output load
o=X. -----89ABCDEF	--
o=.X 1-3-5-7-9-B-D-F	Commands code masked on display
o=.X -23--67--AB--EF	Battery test disabled
o=.X ---4567----CDEF	--
o=.X -----89ABCDEF	--

for example: o=02 Battery test disabled  
o=23 command active: auto off for Timer off , Commands code masked on display  
and Battery test disabled

**--NORMAL OPERATION:**

signalling message to indicate that all parts of the unit are operating correctly.

10:

Example of identifying initials of the type of unit with 10kVA rated power.

**OUT = 100%VA:**

Example of indication of the percentage of power absorbed by the load at output when the inverter is operating.

The initials OUT change to BY when the load is not powered by the inverter but by the mains through the bypass line. All the indication OUT=100%VA changes to OUT=SWMB when load is powered through line of maintenance bypass switch, hence it is not possible to supply measurement of the output load current.

The value 100%VA supplied in the example is taken from the measurement of the output current. The number indicates the output current with the value relative to the absolute rated value and the value indicated is the greater of effective current or peak current.

**BATT=100%Ah:**

Example of indication of present status of battery recharge percentage. The value 100%Ah is taken from measurement of the charging current and the time elapsed in recharging.

The number indicates the percentage of recharge based on the information of the capacity of the connected battery and the amount of charge used during battery operation. The system remains automatically on quick charge for the entire time necessary to supply the battery with the quantity of charge lost during discharge.

The indication %Ah changes to min. during operation in absence of mains power supply or with battery discharged.

In this case the numerical value refers to the remaining minutes of operation calculated on the basis of the current delivered by the battery and the charge status thereof.

**NOTE**

The autonomy indicated is calculated on the basis of measurement of the discharge current at that moment, the value memorised for the capacity of the connected battery and the value memorised for the percentage of charge preceding the discharge. The autonomy value shown is always approximate because of the large number of factors involved.

If large differences are noted between the expected value and the real time of a discharge with steady load, check the memorised battery data and its status.

**5=0N:**

Example of the indication for sound alarm enablement status; in case of exclusion, the indication changes to 5=OFF.

**KEY MENU 1, "?", HELP**

1=?, 2=Measures,3=Commands,4=History 6= Date/Time, 7= Codes, 8=Normal
--

Access to the HELP menu is by pressing key 1 from the basic menu and indicating the menu to which to accede by pressing the other keys form the basic menu.

When many other menus are active push-button 1 returns to basic menu.

1=? indicates button 1 for access to language change menu

2=MEASURES indicates button 2 for access to measurements menu

3=COMMANDS indicates button 3 for access to command entry menu or selection or customizing of operating values.

4=HISTORY indicates button 4 for access to menu for viewing events recorded in internal memory.

6=DATE/TIME indicates button 6 for access to menu for viewing and management of internal clock and calendar.

7=CODES indicates button 7 for access to menu for viewing internal codes corresponding to operating status of all the internal subassemblies.

8=NORMAL indicates button 8 for immediate return to basic menu NORMAL which also takes place automatically after two minutes from the last pressing of key.

**Key menu 1, 1: LANGUAGES**

2=Italiano 3=English 4=Francais 5=Deutsch 6=Espanol 7=
---

Access to the LANGUAGES menu is by key 1 only from HELP menu 1.  
Pressing key 7 to see next menu':

2=Nederland 3=Svenska 4=Polski
--------------------------------

Pressing the key corresponding to the desired language selects the language with which the system supplies all the following messages.

Language selection remains memorised even after turning off and restarting the system.  
To change current language always use LANGUAGES menu.

**Key menu 2 "MEASURES"**

Access to the menu VOLTAGE MEASUREMENTS is by key 2 only from basic menu.

Pressing key 1 returns immediately to the basic menu.

The contents of the measurements menu is different for single-phase and 3-phase units.

Threephase output:

IN=100,100,100%V, 50.0Hz; 101,101,101%Ain BY=220,221,222VI, 50,1Hz;
--

The measurements indicated have the following meanings:

IN=100,100,100%v, 50.0Hz	Examples of measurements of the three voltages measured at the power input. The voltage is expressed in percentage of rated value; the value 100%V indicates a voltage of 230Vln (ln = voltage between phase and neutral).
50.0Hz	input frequency.
101,101,101%Ain	Example of measurement of the three currents at the power supply inlet, viewed by the three sections making up the input rectifier.
BY=220,221,222VI	Current is expressed in percentage of maximum input value.
50,1Hz	Example of measurement of the three voltages at the input of the bypass line \ measured between the phases 1,2,3 and neutral. by-pass line frequency input

singlephase output:

IN=100,100,100%V, 50.0Hz; BY=220V, 50.1Hz OUT=230V, 50.1Hz; 100%W, 100%A; 147%Ap;
--

Access to the menu VOLTAGE MEASUREMENTS is by key 2 only from basic menu.

Pressing key 1 returns immediately to the basic menu.

The contents of the measurements menu is different for single-phase and 3-phase units.

The measurements indicated have the following meanings:

The measurements indicated have the following meanings:

IN=100,100,100%V,	Examples of measurements of the three voltages measured at the power input. The voltage is expressed in percentage of rated value; the value 100%V indicates a voltage of 230Vln (ln = voltage between phase and neutral).
BY=220V,	by-pass line voltage;
50.0Hz	input by pass line frequency;
OUT=230V, 50,1Hz; 100%W, 100%A; 147%Ap	voltage, frequency, W power, effective current and peak current percentages

During operation on bypass the sign OUT changes to BY.

During operation with the switch SWMB for the maintenance bypass current measurements are not possible, hence only the voltage measurements remain and the indication changes to OUT=SWMB.

**Key menu 2, 2 : “Measures output”**

Threephase output

OUT=230,230,231Vln;50.0Hz; 100,100,100%W 100,100,100%A; 147,147,147%Ap
---

Access to the menu is by key 2 from menu 2,2, only in systems with 3-phase output voltage.  
Key 1 returns to basic menu.

OUT=230,230,231Vln	Example of measurement of the three output voltages measured between phases 1, 2, 3 and neutral
50.0Hz	output system frequency
100,100,100% W	Example of measurement of the three output power, the power is expressed in percentage of rated value.
100,100,100% A	Example of measurement of the three system output currents, current is expressed in percentage of maximum input value
147,147,147% Ap	example of measurement of the three peak current percentages for the three output phases during operation on the inverter.

During operation on bypass the sign OUT changes to BY.  
During operation with the switch SWMB for the maintenance bypass current measurements are not possible, hence only the voltage measurements remain and the indication changes to OUT=SWMB.

Singlephase output.

BATT=+323, -323V;+0,0A; i=230V, 360V+, 360V- Ts=28, Tr=50, Ti=49, Tc=29°C; IN=101%A
--

Pressing key 2 causes return to preceding menu. Key 1 returns to basic menu.

BATT=+323, -323V	battery voltage, positive and negative branch with battery connected, battery charger voltage with battery fuse open (in this case the read value could oscillate);
+0,0A	battery current, positive if battery in discharge ,negative battery in charge;
i=230V	output voltage inverter;
360V+, 360V-	inverter input dc voltage;
Ts=28, Tr=50, Ti=49,	system, module converter, module inverter internal temperature;
Tc=29°C,	choke inverter and converter temperature;
IN=101%A	Example of measurement of the current at the power supply inlet, the current is expressed in percentage of rated value.

**Key menu 2, 2, 2 : measures.**

Only threephase output:

BATT=+323, -323V;+0,0A; i=230V, 360V+, 360V- Ts=28, Tr=50, Ti=49, Tc=29°C; IN=101%A
--

Pressing key 2 causes return to preceding menu. Key 1 returns to basic menu.

BATT=+323, -323V	battery voltage, positive and negative branch with battery connected, battery charger voltage with battery fuse open (in this case the read value could oscillate);
+0,0A	battery current, positive if battery in discharge ,negative battery in charge;
i=230V	output voltage inverter;
360V+, 360V-	inverter input dc voltage;
Ts=28, Tr=50, Ti=49,	system, module converter, module inverter internal temperature;;
Tc=29°C,	choke inverter and converter temperature;
IN=101%A	Example of measurement of the current at the power supply inlet, the current is expressed in percentage of rated value.

**Key menu 2, 6: TIME MEASUREMENT**

OUT= 10000h; BY= 10000h; BATT= 10000sec nBATT= 1000; n0%Ah= 100; 2002-01-01
--

Pressing key 1 causes return to the basic menu. The values indicated have the following meanings:

OUT = 10000h	Example of indication of hours elapsed in operation with load on inverter.
BY = 10000h	Example of indication of hours elapsed in operation with load on bypass.
BATT = 10000sec	Example of indication of seconds elapsed in operation with battery in discharge.
nBATT = 1000	Example of indication of the number of times the battery started delivering and hence also the number of times supply voltage was lacking.
n0%Ah = 100	Example of indication of the number of times the battery was completely discharged to 0%Ah. The number of complete discharge cycles is useful for knowing and appraising the efficiency of the battery.
2002-01-01	Example of indication of date memorised for day when the unit was activated for the first time.

The above data constitute the HISTORY and remain memorised even with the unit turned off and cannot be zeroed.

**KEY MENU 3 "KEY", COMMANDS**

2=BATTERY TEST 4=DISPLAY CONTRAST 5=CUSTOMIZING 6=BYPASS 7=SYSTEM OFF
--

In this case the viewer proposes the choice for the subsequent submenus.

**Key menu 3, 2: BATTERY TEST**

BATTERY TESTING FOR 8 sec. BATT= +396 -396V + 2,4A; Vbc= 370V; 100 min
---

Access to the BATTERY TEST menu is by key 2 from menu 3 COMMANDS.

In this case there is activated the cycle of efficiency status checks of the battery, which last 8 seconds.

Pressing key 8 interrupts the test and returns to the basic menu before the end of the period.

The values indicated are:

BATT= +396 -396V + 2,4A Example of indication of battery voltage and current measurement.

Vbc= 370V Example of indication of calculated battery voltage

100 min. Example of indication of calculated autonomy time.

The battery test cycle with rectifier output voltage drop permits evaluation of the battery with the true delivery on the load even during the presence of the power supply voltage. In any case, lowering of the output voltage of the rectifier takes place only if there is voltage on the bypass line so as to avoid any ANOMALY with output load without the bypass reserve.

At the end of the test cycle a comparison is made of the voltage supplied by the battery and a 'Vbc' voltage calculated on the basis of the measured delivered current at the capacity values of the battery and half the percentage of recharge contained in the memory.

If the voltage measured on the battery is less than calculated voltage:

- the alarm BATTERY DISCHARGE or SWB OPEN is activated;
- the memorised recharge percentage is halved;
- the next test cycle is prepared and will be activated automatically after 60 seconds.

The battery test cycle is activated:

- manually;
- automatically every 60 seconds after each failed test or each system starting;
- automatically every 24 hours;
- automatically and invisibly during operation without mains power supply.

At the end of each test, if the measured voltage is less than that calculated the alarm is activated followed by halving of the memorised charge and of the indicated autonomy time.

When 60 seconds have elapsed after activation of the alarm a new test is performed and if the result is negative the alarm is reactivated for another 60 seconds. The alarms continues to halve the memorised charge value until the value for which the battery voltage calculated is less than actually measured.

In practice, this battery check system produces an alarm each time the battery has less than the design charge.

The PERMANENT presence of this alarm indicates that the battery is inefficient or the battery circuit is broken or the battery switch SWB is open or one of the protective fuses has blown.

TEMPORARY presence indicates a loss of battery efficiency proportionate to the alarm frequency.

**Disabling BATTERY TEST**, type keys 3, 5: "CUSTOMISING", insert code 323232. To reactivate insert code 323232 again.

#### **Key menu 3, 4: DISPLAY CONTRAST**

DISPLAY CONTRAST : 6 ADJUSTMENT:                   7=-, 8=+
--

Access to the DISPLAY CONTRAST menu is with key 4 from menu 3 COMMANDS.

In this case it is possible to change the viewer contrast: decrease with key 7; increase with key 8. The value 6 expresses the contrast level and can change from 1 to 11. To leave the menu, press one of the other keys different from 7 and 8, e.g. key 1.

#### **Key menu 3, 5: CUSTOMIZING**

TYPE CODE _____
-----------------

Access to the CUSTOMISING menu starts with key 5 from menu 3 COMMANDS, after which an intermediate menu appears in which it is necessary to insert a series of keys to obtain the final menu.

The sequence "CODE OF CUSTOMISING" **is the same in all cases** and is 436215.

Access to the CUSTOMISING menu using the code must prevent unauthorised persons from modifying the operation parameters of the machine. Code isn't required again for 2 minutes after its first insertion.

Only with the insertion of the correct code can you have access to the following menu, otherwise you are returned to the main menu.

2=Rated Output Voltage   3=Battery   8=Stby 4=Prealarm   6=Auto-OFF   7=Others
---

By pressing key 7 you get the second part of the menu:

2=BY. VOLT. RANGE   3=BY. FREQ. RANGE 4=Conf.   5=RS232   6=ECHO   7=IDENT.
--

In the 2 cases by pressing one of the keys 2, 3, 4, 5 you have access to the following operative sub-menus, while with key 8 "↑", you are returned to menu 2 of base.

#### **Key menu 3, 5, 436215, 2: CUSTOMIZING RATED OUTPUT VOLTAGE**

Rated Output Voltage =   225VIn Adjustment:                   7=-, 8=+
---

You can exit the menu by pressing a key different from 7 and 8.

Keys 7 and 8 are used to reduce or increase the rated output voltage in the range from 200V to 250V with increments of 1V.

In the example, the rated output voltage has been set for 225V measured between phase and neutral 'VIn'.

Note that even in the systems only the voltage between phase and neutral 'VIn' is in referred to.

The value set in the example changes operation of the inverter so as to have output voltage of 225V between phase and neutral, during normal operation.

In addition, the reference voltage for the range of acceptance of the input voltage of the bypass line is also set at 225VIn. The range of acceptance of the power supply voltage remains unchanged and cannot be changed.

**Key menu 3, 5, 436215 ,3: BATTERY CUSTOMIZING**

Battery Type=1	Capacity=12Ah
Adjustment:2-/3+	5/6=-/+10 7=-,8=+

Keys 2/3 require to choose type.

With keys 5, 6, 7 and 8 it is possible to decrease or increase the value of the capacity of the battery contained in memory, with variations of 10 units or of 1 unit, in a field from 1 to 9998 Ah.

You must insert the nominal capacity value of the battery connected. This is usually also printed on the container of the battery itself.

All machines supplied complete with battery, are customised in the factory.

In the case of machines supplied without batteries it is necessary to insert the correct values, otherwise the system uses value of 12Ah.

With keys 2 and 3 it is possible to decrease or increase the identification value of the type of battery.

In the case of batteries with high discharge intensity you must pass from a value of 1 (normally predetermined for normal batteries) to a value of 2, value 3 is used for lead-acid no sealed batteries.

By choosing type 0 and pressing key 4 again it is possible instead to set the following values manually:

Only for UPS with 32 batteries :

Vb_min=160	Vb_ch=217	Vb_max=222
Adjustment: 2-/3+ ,	5-/6+	7=-,8=+

Vb\_min (end discharge voltage) =150÷180V

Vb\_ch (maintenance voltage) = 200÷230V

Vb\_max (charge voltage) = 200÷230V

Only for UPS with 48 batteries :

Vb_min=240	Vb_ch=326	Vb_max=333
Adjustment: 2-/3+ ,	5-/6+	7=-,8=+

Vb\_min (end discharge voltage) =225÷270V

Vb\_ch(maintenance voltage) = 300÷340V

Vb\_max(charge voltage) = 325÷340V

The checking system uses data concerning the capacity and type of battery for:

- automatic check by the inverter of the efficiency of the battery;
- calculation of estimate of residual autonomy time;
- calculation of levels of battery voltage to activate the pre-alarm and afterwards the shut-down;
- establishing best value for the recharging current.

**Key menu 3, 5, 436215 4: PREALARM CUSTOMIZING**

(229Vmin, 247Vp)	Prealarm	5 min.
Adjustment:	7=-, 8=+	

You can exit the menu by pressing a key different from 7 and 8.

Vmin= minimum voltage of the battery ;

Vp= voltage of the discharge pre-alarm ( these two values of voltage Vmin and Vp aren't fixed values, but are a function of battery discharging  $Vp = Vmin + 5V + 10 * (\text{current of the battery [A]} / \text{capacity of the battery [Ah]})$ )

With keys 7 and 8 it is possible to decrease or increase the time required to activate the pre-alarm before the system lock itself due to the complete discharge of the battery. Variations of a minute are possible within a field ranging from 2 to 254 minutes. The pre-alarm signal activates itself when the estimated remaining time is less than the value set for the pre-alarm or when the battery voltage is lower than the value Vp of the pre-alarm voltage. It is important to allow a broad safety margin when using the pre-alarm function, since the value of autonomy required cannot foresee possible increases in absorption for the output load, and cannot take into consideration unexpected and unforeseen faults in the battery, such as, for example faulty single elements or connections.

**Key menu 3, 5, 436215 6: AUTO-OFF CUSTOMIZING "VA"**

Automatic Switch-Off When Adjustment: (5=Toff, 6=Ton)	Output < 10%VA 7=-, 8=+
--	----------------------------

To leave the menu press any key other than 7 and 8.

Keys 7 and 8 are used to reduce or increase the percentage of output load for the AUTO-OFF function. Increments of adjustment are by 1 % in the range from 0 to 99%.

When the AUTO OFF alarm is present, if the input main line voltage is present and the battery charge is lower than 60% there is only the display of:

Bypass for Output VA < AUTO-OFF Value H100, OUT=100%VA BATT= 50%Ah 5=ON
--

The system does not start the "off procedure" because it waits to charge the battery over 60%.

When the alarm is present, if the input main line voltage is present and the battery charge is higher than 60%, or if the system is in battery operation, there is the display of:

Bypass for Output VA < AUTO-OFF Value H100, OUT=100%VA OFF: 4 min, 5=ON
--

Moreover the "prealarm low battery" remote alarm contact switches on alarm position.

In the case of status displayed above, the system continue to operate for the next 4 minutes, after those it switches on bypass.

The interval of time between the arise of alarm and the switching on bypass is by default 5 minutes or it is equal to the value fixed when customizing PREALARM.

After the prealarm time, if the input bypass line voltage were present before, the system switches on bypass and it remains in standby status waiting for increasing of output load over the AUTO-OFF value.

If the input bypass line voltage is NOT present when the prealarm time is finished, the system switches off.

After that, when the input bypass line voltage will come back, the system will start again remaining on bypass in standby status waiting for increasing of output load over the AUTO-OFF value to perform automatic return to normal operation.

The AUTO-OFF function is more useful for turning off the system during battery operation by merely turning off the output load. In case of normal operation, the AUTO-OFF function is still useful for zeroing consumption since the power circuits are deactivated, the battery is isolated and only the control circuits with consumption equivalent to a light bulb remain active.

### **Key menu 3, 5, 436215, 6, 5 (6): AUTO-OFF Timer CUSTOMIZING**

Auto-OFF Timer: Toff >0: 0', Ton= 0: 0' Adjustment: (5=Toff, 6=Ton) 7=-, 8=+
---

To leave the menu press any key other than 7, 8, 5, 6.

Key 5 to adjust Toff, 6 to adjust Ton.

The Toff and Ton values fix the clock time in which operates the daily cycle for self-stopping and self-starting.

This timer cycle is inhibited if Toff and Ton value are equal.

When the internal clock is 20:00, if the input main line voltage is present and the battery charge is lower than 60% there is only the display of:

Auto-OFF Timer: Toff=20:00', Ton= 7:00' _20, OUT=100%VA BATT= 50%Ah 5=ON
---

The system does not start the "off procedure" because it waits to charge the battery over 60%.

When the internal clock is 20:00, if the input main line voltage is present and the battery charge is higher than 60%, or if the system is in battery operation, there is the display of:

AUTO-OFF Timer: Toff=20:00', Ton= 7:00' _20, OUT=100%VA OFF: 4 min, 5=ON
---



Moreover the "prealarm low battery" remote alarm contact switches on alarm position.

In the case of status displayed above, the system continue to operate for the next 4 minutes, after those it switches on bypass.

After the disactivation , the output voltage is absent,

When the time is equal to Ton(7:00') the UPS return in normal operation.

### **Key menu 3, 5, 436215, 7, 2: BYPASS VOLTAGE RANGE CUSTOMIZING**

BY. Voltage Range	+/- 15%
Adjustment:	7=-, 8=+

The code is not required for 2 minutes after its first previous entry.

To leave the menu press a key different from 7 or 8. Keys 7 and 8 are used to reduce or increase the percentage of the range of acceptance of the voltage at the bypass line input. The choice is between the values:  $\pm 1\%$  to  $\pm 25\%$  of the value set for RATED OUTPUT VOLTAGE (normally the value is set  $\pm 15\%$ ).

With UPS in mode Stby=ON The menu' is the following:

(StbyON=10%) BY. Voltage Range	+/- 15%
Adjustment: (5-, 6+)	7= -, 8= +

Keys 5 and 6 are used to reduce or increase the percentage of the range of acceptance of voltage in STBY mode on bypass line. If the bypass line voltage is without of the fixed value, the UPS output change from by-pass line (stby mode) to inverter output.

### **Key menu 3, 5, 436215, 7, 3: BYPASS FREQUENCY RANGE CUSTOMIZING**

BY. FREQUENCY RANGE	+/- 2%
Adjustment:	7=-, 8=+

The code is not required for 2 minutes after its first previous entry.

To leave the menu press any key other than 7 and 8. Keys 7 and 8 are used to reduce or increase the percentage of the range of acceptance of frequency at the bypass line input. The choice is between 1% to  $\pm 5\%$  for rated value of the system of 50Hz or 60Hz. Rated frequency of the system can only be selected inside the unit.

### **Key menu 3, 5, 436215, 7, 4 : MODEM CUSTOMIZING**

4=Dial/Send; MODEM -1 = 0; MODEM-2 = 0	
Adjustment: 5=-, 6=+;	7=-, 8=+

The code is not required for 2 minutes after its first previous entry.

To leave the menu press a key different from 7, 8, 5, 6, 4.

Keys 7 and 8 are used to reduce or increase the control value for modem operation, the range is from 0 to 5 and 0 is default value.

**Value 0** = the pin n. 20 ( DTR ) of RS232 connector is set to low level (-12V) to inhibit the operation of a connected modem.

NOTE: when a remote control panel is connected to the RS232 connector, instead of a modem, the value MUST BE SET to 0 otherwise the remote panel does not operate.

**Value 1**= the pin n. 20 ( DTR ) of RS232 connector is set to high level (+12V) to enable the operation of answer for a connected modem. (Remember that with this value a connected remote panel does not operate).

**Value 2**= the pin n. 20 ( DTR ) of RS232 connector is set to high level (+12V) to enable the operation of answer and automatic calling for a connected modem.

When the automatic calling is set, 30 seconds after all "INTERNAL FAULT n" alarm the system gives to the modem the command "ATD" followed by the memorized "Dial" number.

The modem must be previously set to recognize the "HAYES" command and to dial numbers with pulses or tones as required by the used telephone line.

After the ATD and Dial number, the system send to the modem the memorised "Send" number and a copy of the panel display with a=..... code and date/time.

For example, if Dial = 123456, Send = 456789, 30 seconds after starting of alarm "Internal Fault 5" the system sends to modem:

```
ATD123456.
```

The system, after receiving the message "CONNECT" from modem, sends to the modem the message:

```
UPS 456789
```

```
INTERNAL FAULT
```

```
M100, OUT=100%VA, BATT= 78%Ah, 5=On a=00200300 1994-12-21, 13:24:28
```

The system sends also the sequence to close connection:

```
+++ ATH
```

As last the system put on low level the DTR signal for 0.5 sec.

In case of busy line or modem not giving the response "CONNECT", the system wait 5 minute than repeats again the commands ATD..... in order to try another phone call. The system continues to try calling every 5 minutes until it receives the response "CONNECT" from modem or the alarm condition disappears.

**Value 3=** like value 2 with the automatic calling for any kind of alarm.

**Value 4=** like value 2 with the automatic calling only with alarm 10 (Internal Fault) but with sending of display message only after received the character "}".

This operation can been used for avoiding the loss of a message, because the system sends its message only after receiving the special character "}" that can send only by a computer.

**Value 5=** like value 4 with the automatic calling for any kind of alarm.

### **Key menu 3, 5, 436215, 7, 4, 5 (6) : Modem 'Dial /Send' CUSTOMIZING.**

MODEM dial n.=6543210//////// <=2..3=> Adjustment: (5=dial, 6=send) 7=-, 8=+
---

The code is not required for 2 minutes after its first previous entry.

To leave the menu press a key different from 7, 8, 5, 6, 2, 3.

Keys 7 and 8 are used to reduce or increase the digit on which the cursor points.

The cursor position is shown in the first time by the symbol "\_", its position can be moved left with key 2 and right with key 3. The digits can be set in the range 0, 1, 2 ... 9, /. The symbol / indicates a digit inhibited.

The correct setting requires only number starting from left. All number inserted after a "/" are ignored.

A setting of "0123/45" will be recognised only as number 0123. Selecting the 35746 menu or pushing the key 6 when the 35745 menu is active, it is possible to adjust the "send" number.

### **Key menu 3, 5, 436215, 7, 5: RS232 CUSTOMIZING**

RS232-1: baud=9600. RS232-2: baud=9600 Adjustment: 3=-, 4=+ 7=-, 8=+
---

The code is not required for 2 minutes after its first previous entry. To leave the menu press any key other than 7, 8, 3, and 4. Keys 7 and 8 (3 and 4) are used to reduce or increase baud transmission speed. The choice is among 1200, 2400, 4800 and 9600.

### **Key menu 3, 5, 436215, 7, 6: ECHO CUSTOMIZING**

Echo RS232-1 = 0 , Echo RS232-2 = 0 Adjustment: 5=-, 6=+ 7=-, 8=+
--

The code is not required for 2 minutes after its first previous entry. To leave the menu press any key other than 7, 8, 5 and 6. Keys 7 and 8 (5,6) are used to reduce or increase the check value of the ECHO function. The choice is between 0 and 1. 0 is starting value. When 1 is selected the ECHO function is activated. The ECHO function is useful for automatically sending to the serial outlet RS232 the same message as appears on the panel viewer.

Automatic sending occurs for each alarm or change in viewer content.

Using this function it is possible to automatically print all messages through a printer connected to the RS232 outlet.

The message includes:

- copying the characters on the viewer

- copying the internal code a=FFFF-FFFF
- date and hour of activation of the message.

NOTE: the ECHO must be set to 0 when using some special software to receive information from UPS by a computer, because in that case the message must be sent only under computer control.

### **Key menu 3, 5, 436215, 7, 7: IDENT. CUSTOMIZING**

IDENT. = 0	
Adjustment:	7=-, 8=+

The code is not required for 2 minutes after its first previous entry. To leave the menu press any key other than 7 and 8. Keys 7 and 8 are used to reduce or increase the identification number of a single unit in case of systems using several UPS units connected to a single RS232 serial line.

The basic number is 0 and can be changed among values from 0 to 7.

### **Key menu 3, 5, 436215, 8: CUSTOMIZING OPERATION IN STANDBY ON**

Stby = 0 min.	Stby_ON = 0
Adjustment: 5-,6+	7 = -, 8 = +

You can exit the menu by pressing a key different from 7 and 8.

By pressing key 8 STBY=1 the UPS switches itself to " normal operation " in STANDBY-ON mode and vice versa by pressing 7.

The passage on line of by-pass can be immediate Stby = 0 min or delayed acting on keys 5 and 6.

The UPS goes in STANDBY ON only if the line of bypass is within the acceptance range (menù "BYPASS VOLTAGE RANGE CUSTOMIZING).

The command remains memorised, even during a shut-down due to lack of feed. For the description on the operation to see the "MODES OPERATION" paragraph.

### **Key menu 3, 5, "642137" : CUSTOMIZING OPERATION IN STANDBY OFF.**

Open the output switch SWOUT before inserting the indicated code. After that inserted code close output switch.

The command remains memorised, even during a shut-down due to lack of feed.

For the description on the operation to see the "MODES OPERATION" paragraph.

To return to the ON LINE modality open SWOUT and inserted the code "642137".

### **Key menu 3, 5, "156234" : CUSTOMIZING STABILIZER .**

Open the output switch SWOUT before inserting the indicated code. After that inserted code close output switch.

The command remains memorised, even during a shut-down due to lack of feed.

For the description on the operation to see the "MODES OPERATION" paragraph.

To return to the ON LINE modality open SWOUT and inserted the code "156234".

### **Key menu 3, 6: INVERTER-OFF/BYPASS**

Inverter OFF and bypass Command = 47263 it shuts OFF, if Bypass line is NOT OK
---

To leave the menu press key 8 or any key with a sequence other than that indicated.

Pressing keys 1, 7, 2, 6 and 3 in succession as shown on the viewer activates the bypass command and shuts off the inverter.

This command is mostly useful if sent through an RS232 remote connection if it is desired to deactivate only the power circuits while keeping the control circuit alive.

The action following the command is executed with a few minutes of delay to allow for cancellations.

When this command is active the viewer shows the alarm BYPASS COMMAND ACTIVE; 8=DISACTIVATION.

To return to normal operation even after shutting off the system it is necessary to cancel the command with key 8 or sending the key code through the RS232.

NOTE. To mask the code of the command, 47263, you must insert code 436213, in the CUSTOMISING menu on the panel (keys 3,5). Repeat the operation to display the code.

### **Key menu 3, 7: TOTAL SYSTEM SHUT-OFF COMMAND.**

Total System Shut-Off Command = 47263  
Warning, The Output Voltage Will Be Off

Exit from the menu is obtained by pressing key 8 or any other key with a different sequence from that indicated. By pressing keys 4, 7, 2, 6, 3, one after the other, as shown on the display, the activation of the command for the SYSTEM OFF is obtained. When this control is active, the display presents the alarm

SYSTEM OFF COMMAND ACTIVE ; 8=DISACTIVE.

The action following the command is carried out with a few seconds of delay to permit possible cancellations. This control is useful in the event of an emergency to obtain complete disactivation, operating from a distance through line RS232. To reactivate the UPS close SWBY or, if required, press button 8 on the local or remote panel.

NOTE. To mask the code of the command, 47263, you must insert code 436213, in the CUSTOMISING menu on the panel (keys 3,5). Repeat the operation to display the code.

### **KEY MENU 4: "RECORDER": HISTORY = RECORDED EVENTS**

---

alarm message recorded  
a=FFFF-FFFF; n=100, 1992,12,31/14:45:50

Access to the RECORDED EVENTS menu is with key 4 of the basic menu.

Press key 1 to return to the basic menu.

Key 2 activates the sub menu MEASUREMENT OF RECORDED VOLTAGES.

Keys 3, 4 and 5 remain with normal functions.

Key 6 activates the sub menu 4, 6 RECORDED CODES and permits exchange of the alarm message memorized with display of the status codes corresponding to the moment of the memorized event and vice versa.

The status codes permit thorough analysis of the event. For interpretation see the menu of the key 7 INTERNAL CODES and the table of memorized codes.

Keys 7 and 8 secure display of the events preceding and following the event displayed. For example by pressing 7 the indication n=100 changes to n=99 and the 'memorized alarm message' of the previous event is shown.

The parts of the menu are:

memorized alarm message	Indicates one of the alarm messages corresponding to that displayed during the last event and contained in the memory of the events. The memory can contain up to 120 events. When the memory is full each new event is memorized and cancels the last one.
a=FFFF-FFFF	Indicates the memorized code for the other alarms present at the same time together with that indicated by the 'memorized alarm message'.
n=100	Indicates the number of events contained in the memory.
1992,12,31/14:45:50	Indicates the date and hour of the moment when the displayed event occurred. It is expressed in year, month, day / hour, minute, second

### **Key menu 4, 2 RECORDED VOLTAGES MEASUREMENT**

IN=100,100,100%V,50.0Hz; BATT=430V,+100A  
BY=230V,50.0Hz; n35\_OUT=220V,50.0Hz,100%

Access to the menu RECORDED VOLTAGES MEASUREMENT is with key 2 only from menu 4 RECORDED EVENTS or menu 4,6 RECORDED CODES.

Press key 1 to return immediately to the basic menu.

In the example, n35 (flashing) indicates that the measurements shown are for the status of recorded event 35.

The meaning of the measurements is identical to those of menu 2.

### **Key menu 4, 2, 2: RECORDED CURRENT MEASUREMENT**

IN=100,100,100%A;Ts=25°C,Tr=45°C,Ti=45°C  
i=230VIn,430Vb;n 35 OUT=100,100,100%Arms

Access to the menu RECORDED CURRENT MEASUREMENT is with key 2 only from menu 4, 2.

Press key 2 to return to menu 4,2; key 1 to return to basic menu.

In the example, n35 (flashing)

indicates that the measurements shown are for the status of recorded event 35.

The meaning of the measurements is identical to those of menu 2.

### **Key menu 4, 2, 2: RECORDED 3-PHASE VOLTAGE MEASUREMENT**

```
BY=230,230,230Vln;  OUT=230,230,230Vln
n 35  OUT=100,100,100Apk
```

Access to the menu 3-PHASE VOLTAGE MEASUREMENT is with key 2 from menu 4,2,2.

Press key 2 to return to menu 4,2,2; key 1 to return to basic menu.

In the example, n35 (flashing)

indicates that the measurements shown are for the status of recorded event 35.

The meaning of the measurements is identical to those of menu 2.

### **Key menu 4, 6: RECORDED CODES**

```
s=FFFF c=FFFF b=FFFF r=FFFF-FF i=FFFF-FF
a=FFFF-FFFF; n=100, 1992,12,31/14:45:50
```

Access to the menu RECORDED CODES is with key 6 from menu 4 RECORDED EVENTS and menus 4,2; 4,2,2; 4,2,2,2, i.e. those of recorded measurements.

Press key 1 to return to basic menu.

The other keys except 6 and the indications of the bottom line have the same functions as those of menu 4.

The top line: s=FFFF c=FFFF b=FFFF r=FFFF-FF i=FFFF-FF,

shows the internal codes, explained in menu 7, recorded at the same time as the event.

Press key 6 to return to menu 4 keeping the event current, then it is possible to go several times from the description of the event with the 'memorized alarm message' to that with the internal codes.

## **KEY MENU 5: ACOUSTIC ALARM EXCLUSION**

During operation with the presence of the basic menu the operator can exclude or again enable permanently the audible alarm by pressing key 5.

In the basic menu 5=ON appears when the audible alarm is enabled and 5=OFF appears when the audible alarm is excluded.

In other menus, when other functions are not provided, key 5 can be used only for sound exclusion.

## **KEY MENU 6: "CLOCK": DATE/TIME**

```
DATE/TIME= ymd/h = 2000 12 31/24:60'60
TYPE CODE ....
```

Access to the DATE/TIME menu is with key 6 from the basic menu.

The viewer shows the present contents of the internal calendar and clock in the format:

**DATE/TIME = ymd/h=year,month,day/hour,minute,second**

It is possible to change the contents by recalling the related menu by entry of the customizing code **436215**.

The code is not required for 2 minutes after the first previous entry thereof.

Only entering the correct code secures access to the next menu, otherwise one returns to the basic menu.

```
DATE/TIME= ymd/h = 1993 12 31/24:60'60
Adj.: 2=ye. 3=mo. 4=day. 5=hours 7=min..
```

The number to be changed is selected with one of the keys 2, 3, 4, 5 or 7.

```
DATE/TIME= Xmd/h = 1993 12 31/24:60'60
ADJUSTMENT:          7=-, 8=+
```

In this case it was decided to change the year, the flashing symbol X superimposed on the letter a recalls the field selected. Pressing key 7 or 8 increases or decreases by one unit the value selected. Pressing one of the other keys exits from menu.

## KEY MENU 7 "ARROW DOWN": INTERNAL CODES

s=FFFF c=FFFF b=FFFF r=FFFF-FF i=FFFF-FF a=FFFF-FFFF; INTERNAL CODES; ver.10001
--

(memorized internal codes)

Access to the INTERNAL CODES menu is with key 7 from the basic menu.

Press key 7 again to accede to the second menu of internal codes. Press any other key to exit.

e=FFFF g=FFFF u=FFFF y=FFFF j=FFFF-FFFF k=FFFF v=FFFF p=FFFF l=FFFF m=FFFF-FFFF
--

(UNmemorized internal codes). N.B. these codes are used only during the testing in factory.

In the first menu, ver. 10001 is an example of an identifying number of the system programme version.

## KEY MENU 8 "ARROW UP": NORMAL

NORMAL OPERATION M100, OUT=100%VA BATT.=100%Ah 5=ON
--

Access to the menu NORMAL is with key 8 from menu 1 HELP and from all the other menus in which no other function is provided. In addition, the system returns AUTOMATICALLY to the menu NORMAL, i.e. the basic menu, always after two minutes after last pressing a key. All functions are those explained for the basic menu.

APPENDIX

INTERNAL LAYOUT

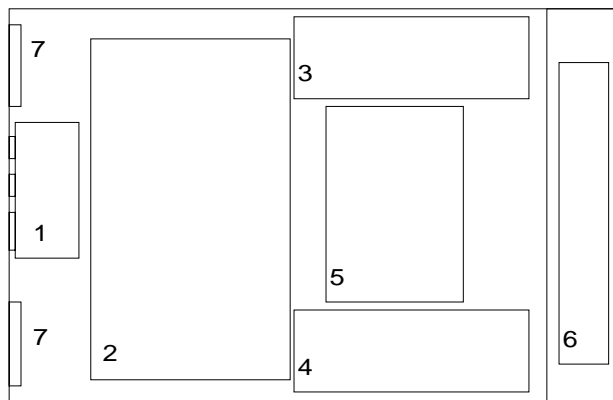

- 1 scheda RS232 / RS232 board
- 2 alimentatore carica batterie / power supply and battery charger
- 3 controllo inverter / inverter control
- 4 controllo booster / booster control
- 5 micro sistema / micro system
- 6 pannello LCD / LCD panel
- 7 ventilatori / fans

SINGLEPHASE OUTPUT

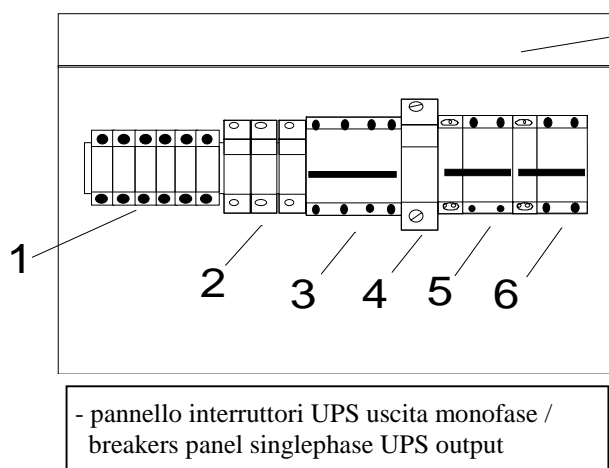

- 1. morsettiera ingresso-uscita /input-output terminal board
- 2. fusibili ingresso batteria / input battery fuses
- 3. interruttore di ingresso SWIN / SWIN input breaker
- 4. fusibile linea di by-pass FBY / FBY by-pass line fuse
- 5. interruttore di uscita SWOUT/output breaker SWOUT
- 6. interruttore di manutenzione SWMB / SWMB maintenance breaker
- 9. pannello display / display panel

THREEPHASE OUTPUT 10-20kVA

- 1 morsettiera ingresso / input terminal board
- 2 fusibili ingresso batteria / input battery fuses
- 3 interruttore di ingresso SWIN / SWIN input breaker
- 4 fusibili linea di by-pass FBY / FBY by-pass line fuses
- 5 interruttore di uscita SWOUT / SWOUT output breaker
- 6 interruttore di manutenzione SWMB / SWMB maintenance breaker
- 7 pannello display / display panel

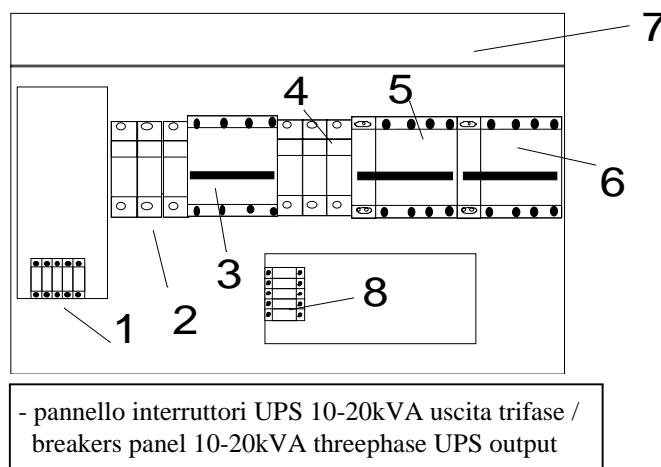

**THREEPHASE OUTPUT 30kVA**

1. morsettiera ingresso / input terminal board
2. fusibili ingresso batteria / input battery fuses
3. interruttore di ingresso SWIN / SWIN input breaker
4. fusibili linea di by-pass FBY / FBY by-pass line fuses
5. interruttore di uscita SWOUT / SWOUT output breaker
6. interruttore di manutenzione SWMB / SWMB maintenance breaker
7. pannello display / display panel

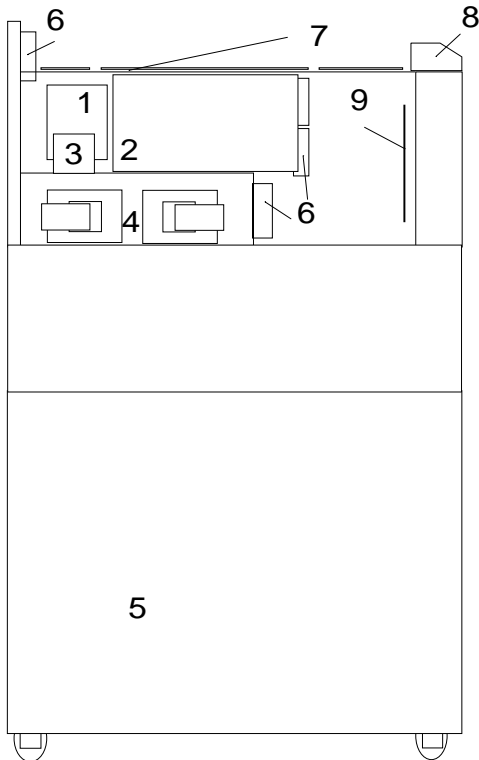
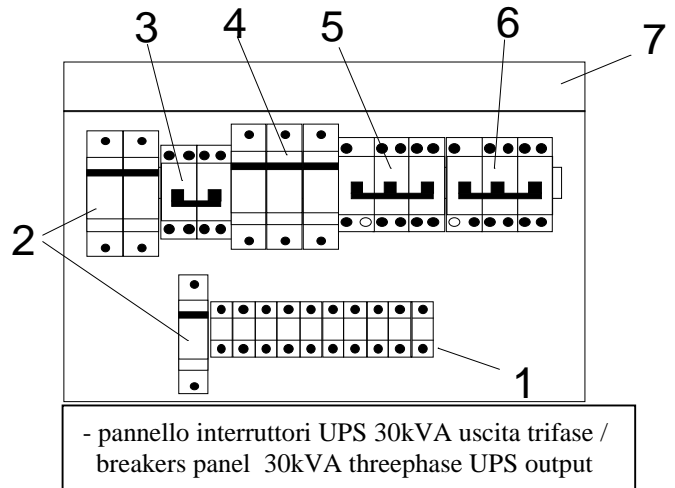

**Left side**

- 1 scheda ingresso / input board
- 2 scheda booster / booster board
- 3 TLR teleruttore ingresso / TLR input contactor
- 4 Induttanze uscita e booster / booster and output coil
- 5 Vano batteria / battery box
- 6 Ventilatori / fans
- 7 Vassoio schede / boards plate
- 8 Pannello LCD di comando / LCD command panel
- 9 Scheda filtro ingresso-uscita (solo nella versione monofase) / input-output filter bord (only singlephase version)

**right side**

- 1 scheda by-pass (solo trifase version) / by-pass board (only threephase version)
- 2 scheda inverter / inverter board
- 3 TLI teleruttore inverter / TLI inverter contactor
- 4 Induttanze uscita e booster / booster and output coil
- 5 Vano batteria / battery box
- 6 Ventilatori / fans
- 7 Vassoio schede / boards plate
- 8 Pannello LCD di comando / LCD command panel
- 9 Scheda filtro ingresso-uscita (solo nella versione monofase) / input-output filter bord (only singlephase version)

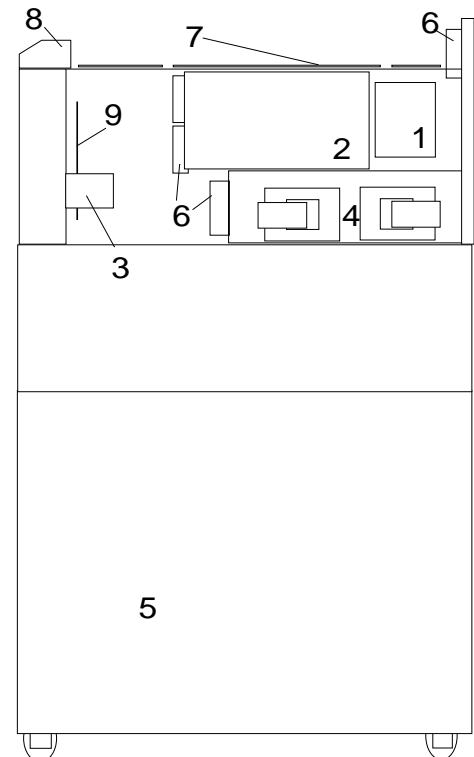



Front

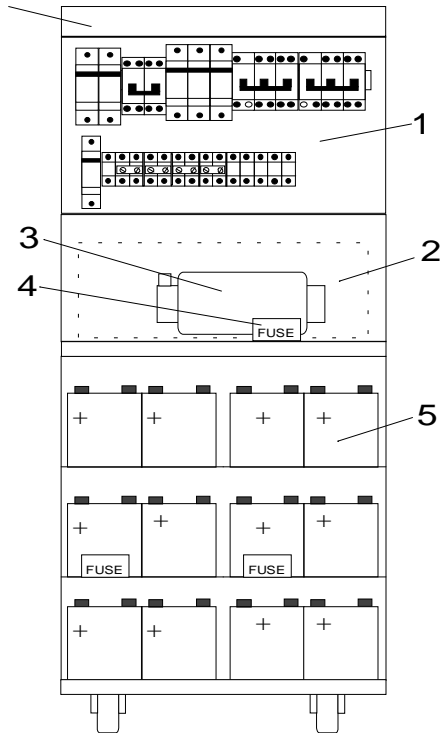

1. Assieme ingresso / input assembly
2. Compensatore armoniche opzionale / harmonic optional
3. Trasformatore compensatore armoniche / harmonic filter transformer
4. Fusibili del compensatore armoniche / harmonic filter fuses
5. Vano batteria / battery box

**Battery Pack Ups / Pacchi Batteria**

Battery plate / vassoio batteria

- 1 Battery plate / vassoio batteria
- 2 Battery / batteria
- 3 Battery cable connection/cablaggio collegamento batteria

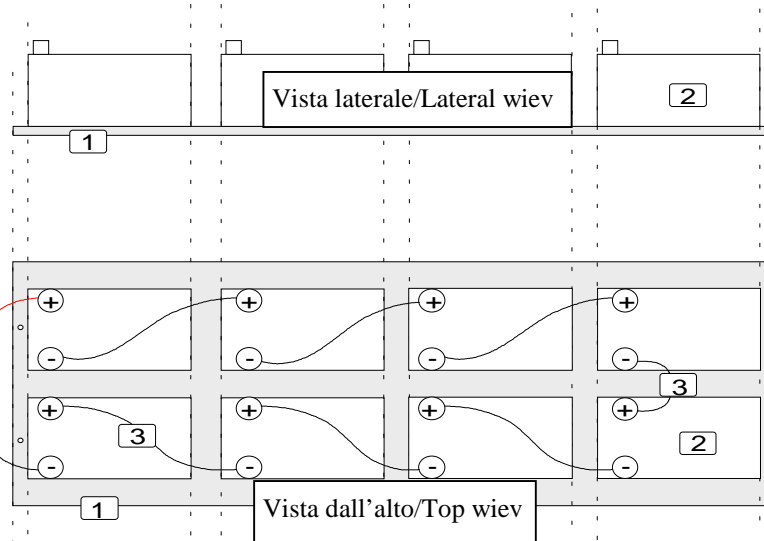

Electrical diagram / Schema elettrico

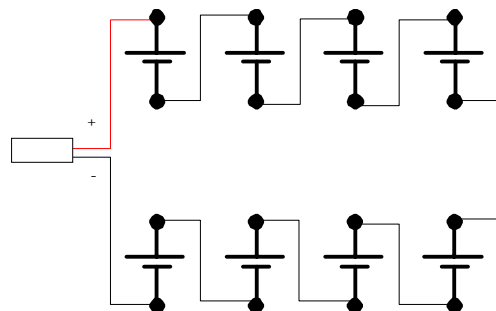

## Battery Plate Connections / Collegamenti Vassoio Batteria

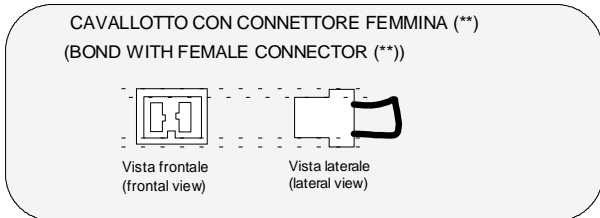
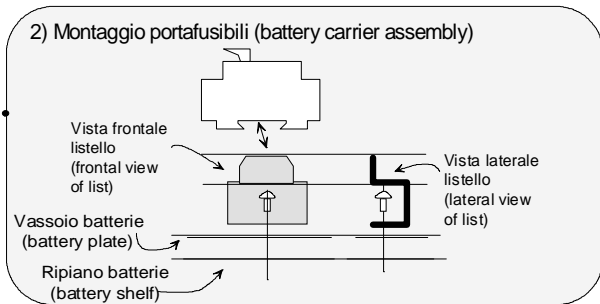
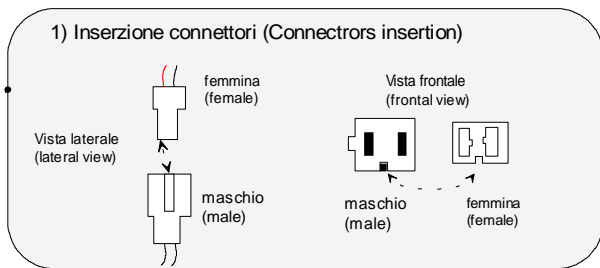
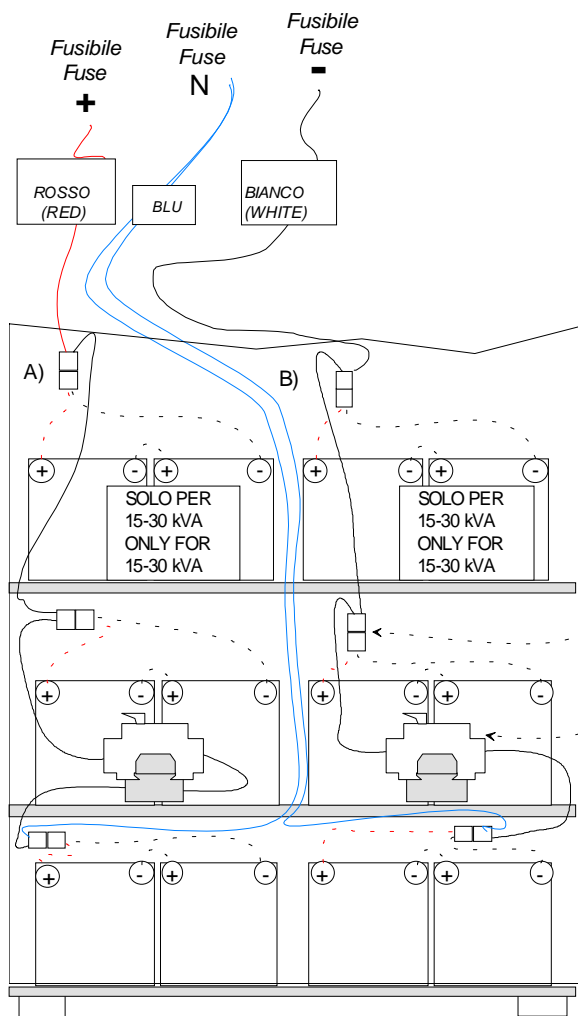

(\*\*) This draw concern the battery wiring for SENTRY MS 15,20,30 kVA. For SENTRY MS 10 kVA there is only 4 battery plate, therefore on connector A) and B) you must insert two female connectors like show in.

(\*\*)Questo disegno riguarda il cablaggio per versioni SENTRY MS da 15,20,30 kVA. Nel caso di versioni da 10 kVA vi sono solo 4 vassoi batterie, perciò sui connettori A) e B) vanno montati due cavallotti con connettore del tipo illustrato.

## DIMENSION WEIGHT / DIMENSIONI PESI

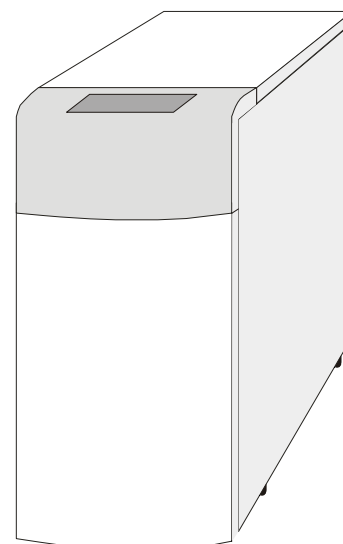
**Singlephase output / Uscita Monofase**

P p.f.0.8 [kVA]	Fasi/phases Input Ingresso	Output uscita	Nr. batt.12V	batt. cap. Ah	Dimensions/dimensioni Lxpxh WxDxH [mm]	Weight/pesi [kg]
10	3+N/1+N	1+N	0	0	450x750x1200	112 (152)
			7	7		204 (244)
			32	12		250 (290)
15	3+N/1+N	1+N	0	0	450x750x1200	122 (147)
			7	7		260 (305)
			48	12		328 (373)
20	3+N/1+N	1+N	0	0	450x750x1200	123 (173)
			9	9		276 (326)
			48	12		329 (379)

(Values among brackets for version with harmonics reduction filter only / I valori tra parentesi sono validi solo per versioni con compensatore di armoniche).

**Threephase output / Uscita Trifase**

P p.f.0.8 [kVA]	Fasi/phases Input Ingresso	Output uscita	Nr. batt.12V	batt. cap. Ah	Dimensions/dimensioni Lxpxh WxDxH [mm]	Weight/pesi [kg]
10	3+N	3+N	0	0	450x750x1200	114 (154)
			7	7		206 (246)
			32	12		251 (291)
15	3+N	3+N	0	0	450x750x1200	122 (167)
			7	7		261 (306)
			48	12		328 (373)
20	3+N	3+N	0	0	450x750x1200	124 (174)
			9	9		277 (327)
			48	12		330 (380)
30	3+N	3+N	0	0	450x750x1200	144(204)
			48	14		370 (430)

(Values among brackets for version with harmonics reduction filter only / I valori tra parentesi sono validi solo per versioni con compensatore di armoniche).