

USER MANUAL

Geo PMAC Drive

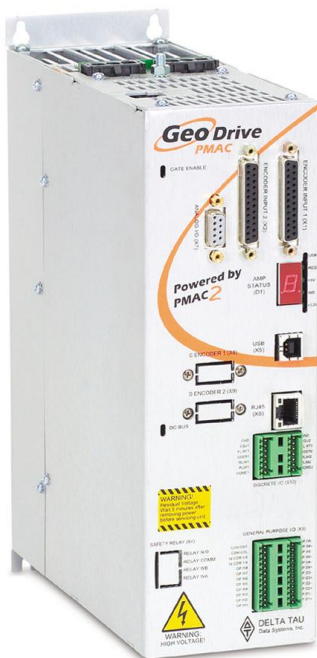

Programmable Servo Amplifier

500-603704-xUxx

April 528, 20106



DELTA TAU
Data Systems, Inc.

NEW IDEAS IN MOTION ...

Single Source Machine Control

21314 Lassen Street Chatsworth, CA 91311 // Tel. (818) 998-2095 Fax. (818) 998-7807 // www.deltatau.com

Power // Flexibility // Ease of Use

Copyright Information

© 20106 Delta Tau Data Systems, Inc. All rights reserved.

This document is furnished for the customers of Delta Tau Data Systems, Inc. Other uses are unauthorized without written permission of Delta Tau Data Systems, Inc. Information contained in this manual may be updated from time-to-time due to product improvements, etc., and may not conform in every respect to former issues.

To report errors or inconsistencies, call or email:

Delta Tau Data Systems, Inc. Technical Support

Phone: (818) 717-5656

Fax: (818) 998-7807

Email: support@deltatau.com

Website: <http://www.deltatau.com>

Operating Conditions

All Delta Tau Data Systems, Inc. motion controller products, accessories, and amplifiers contain static sensitive components that can be damaged by incorrect handling. When installing or handling Delta Tau Data Systems, Inc. products, avoid contact with highly insulated materials. Only qualified personnel should be allowed to handle this equipment.

In the case of industrial applications, we expect our products to be protected from hazardous or conductive materials and/or environments that could cause harm to the controller by damaging components or causing electrical shorts. When our products are used in an industrial environment, install them into an industrial electrical cabinet or industrial PC to protect them from excessive or corrosive moisture, abnormal ambient temperatures, and conductive materials. If Delta Tau Data Systems, Inc. products are directly exposed to hazardous or conductive materials and/or environments, we cannot guarantee their operation.

Safety Instructions

Qualified personnel must transport, assemble, install, and maintain this equipment. Properly qualified personnel are persons who are familiar with the transport, assembly, installation, and operation of equipment. The qualified personnel must know and observe the following standards and regulations:

IEC 364 resp. CENELEC HD 384 or DIN VDE 0100

IEC report 664 or DIN VDE 0110

National regulations for safety and accident prevention or VBG 4

Incorrect handling of products can result in injury and damage to persons and machinery. Strictly adhere to the installation instructions. Electrical safety is provided through a low-resistance earth connection. It is vital to ensure that all system components are connected to earth ground.

This product contains components that are sensitive to static electricity and can be damaged by incorrect handling. Avoid contact with high insulating materials (artificial fabrics, plastic film, etc.). Place the product on a conductive surface. Discharge any possible static electricity build-up by touching an unpainted, metal, grounded surface before touching the equipment.

Keep all covers and cabinet doors shut during operation. Be aware that during operation, the product has electrically charged components and hot surfaces. Control and power cables can carry a high voltage, even when the motor is not rotating. Never disconnect or connect the product while the power source is energized to avoid electric arcing.

After removing the power source from the equipment, wait at least 10 minutes before touching or disconnecting sections of the equipment that normally carry electrical charges (e.g., capacitors, contacts, screw connections). To be safe, measure the electrical contact points with a meter before touching the equipment.

The following text formats are used in this manual to indicate a potential for personal injury or equipment damage. Read the safety notices in this manual before attempting installation, operation, or maintenance to avoid serious bodily injury, damage to the equipment, or operational difficulty.

WARNING:

A Warning identifies hazards that could result in personal injury or death. It precedes the discussion of interest.

Caution:

A Caution identifies hazards that could result in equipment damage. It precedes the discussion of interest

Note:

A Note identifies information critical to the user's understanding or use of the equipment. It follows the discussion of interest.

<u>REVISION HISTORY</u>				
<u>REV.</u>	<u>DESCRIPTION</u>	<u>DATE</u>	<u>CHG</u>	<u>APPVD</u>
1	ADDED SAFETY RELAY PN INFO, P. 38	04/28/10	CP	S.MILICI

Table of Contents

INTRODUCTION.....	9
User Interface.....	9
<i>Geo MACRO Drives</i>	9
<i>Geo Direct-PWM Drives</i>	10
<i>Geo PMAC Drives</i>	10
Feedback Devices.....	11
Compatible Motors.....	11
<i>Maximum Speed</i>	12
<i>Torque</i>	12
<i>Motor Poles</i>	13
<i>Motor Inductance</i>	13
<i>Motor Resistance</i>	13
<i>Motor Back EMF</i>	13
<i>Motor Torque Constant</i>	13
<i>Motor Inertia</i>	13
<i>Motor Cabling</i>	13
SPECIFICATIONS	15
Part Number.....	15
Geo PMAC Feedback Options.....	16
Package Types	16
Electrical Specifications	17
<i>240VAC Input Drives</i>	17
<i>480VAC Input Drives</i>	19
Environmental Specifications	21
Recommended Fusing and Wire Gauge	21
RECEIVING AND UNPACKING.....	22
Use of Equipment.....	22
MOUNTING.....	24
<i>Low Profile</i>	25
<i>Single Width</i>	26
<i>Double Width</i>	27
CONNECTIONS.....	28
System (Power) Wiring	28
Wiring AC Input, J1	30
Wiring Earth-Ground	30
Wiring 24 V Logic Control, J4	31
Wiring the Motors.....	31
<i>J2: Motor 1 Output Connector Pinout</i>	31
<i>J3: Motor 2 Output Connector Pinout (Optional)</i>	31
Wiring the Motor Thermostats.....	32
Wiring the Regen (Shunt) Resistor J5	32
<i>J5: External Shunt Connector Pinout</i>	33
<i>Shunt Regulation</i>	34
<i>Minimum Resistance Value</i>	34
<i>Maximum Resistance Value</i>	34
<i>Energy Transfer Equations</i>	34
Bonding	37
Filtering	37
<i>CE Filtering</i>	37
<i>Input Power Filtering</i>	37
<i>Motor Line Filtering</i>	37
<i>I/O Filtering</i>	38

CONNECTORS.....	39
Connector Pinouts	39
X1: Encoder Input 1.....	39
X2: Encoder Input 2.....	40
X3: General Purpose I/O	41
X4: Safety Relay (Optional).....	44
X5: USB 2.0 Connector.....	44
X6: RJ45, Ethernet Connector.....	44
X7: Analog I/O (Optional, Option 3/4/5)	45
X8: S. Encoder 1.....	46
X9: S. Encoder 2.....	47
X10: Discrete I/O.....	48
J1: AC Input Connector Pinout	51
J2: Motor 1 Output Connector Pinout	51
J3: Motor 2 Output Connector Pinout (Optional)	51
J4: 24VDC Input Logic Supply Connector.....	51
J5: External Shunt Connector Pinout	51
SETTING UP THE ENCODERS.....	52
Setting up Quadrature Encoders.....	52
Signal Format.....	52
Hardware Setup.....	52
Setting up SSI Encoders	53
Hardware Setup.....	53
Software Setup.....	54
Setting up Sinusoidal Encoders.....	58
Encoder Connections	58
Hardware Setup.....	58
Software Setup.....	59
Principle of Operation	60
Setting up EnDat Interface.....	62
Hardware Setup.....	62
Software Setup.....	63
Ix10 Setup for Geo PMAC drive in use with EnDat.....	63
Ix81 Setup for Geo PMAC drive in use with EnDat.....	63
Setting up Resolvers.....	65
Hardware Setup.....	65
Software Setup.....	66
11010 Resolver Excitation Phase Offset	67
11011 Resolver Excitation Gain.....	67
11012 Resolver Excitation Frequency Divider.....	67
Setting Up Digital Hall Sensors	68
Signal Format.....	68
Hardware Setup.....	68
Using Hall Effect Sensors for Phase Reference.....	69
Determining the Commutation Phase Angle.....	69
Finding the Hall Effect Transition Points	70
Calculating the Hall Effect Zero Point (HEZ).....	70
Determining the Polarity of the Hall Effects – Standard or Reversed.....	73
Software Settings for Hall Effect Phasing.....	73
Optimizing the Hall Effect Phasing Routine for Maximum Performance.....	74
Encoder Loss Setup.....	78
Program Accessible Amplifier Status Codes	79
DIRECT PWM COMMUTATION CONTROLLER SETUP	80
Key Servo IC Variables	80
Key Motor Variables	80

DC BRUSH MOTOR DRIVE SETUP	81
I-Variable Setup.....	81
Hardware Connection.....	82
SETTING I²T PROTECTION	83
CALCULATING MINIMUM PWM FREQUENCY	84
TROUBLESHOOTING	85
Error Codes.....	85
<i>DI: AMP Status Display Codes</i>	85
<i>7-segment LED</i>	85
Status LEDs.....	86
APPENDIX A	87
Mating Connector and Cable Kits.....	87
Mating Connector and Cable Kits.....	87
<i>Mating Connector and Cable Kits</i>	87
<i>Connector and Pins Part Numbers</i>	88
Cable Drawings.....	90
Regenerative Resistor: GAR78/48	96
Type of Cable for Encoder Wiring.....	97
APPENDIX B	99
Schematics.....	99
<i>X8 and X9 S.Encoder</i>	99
<i>X3: General Purpose IO</i>	99
<i>X10: Limits for Axis 1 and 2</i>	100
APPENDIX C	101
SUGGESTED M-VARIABLE DEFINITIONS	101
MEMORY AND I/O MAP ADDENDUM	107

INTRODUCTION

The Geo Drive family of “bookcase”-style servo amplifiers provides many new capabilities for users. This family of 1- and 2-axis 3-phase amplifiers, built around a common core of highly integrated IGBT-based power circuitry, supports a wide variety of motors, power ranges, and interfaces. The 2-axis configurations share common power input, bus, and shunt for a very economical implementation.

Three command interfaces are provided: direct-PWM, MACRO-ring, and integrated PMAC controller, each described in following sections. In all three cases, fully digital “direct PWM” control is used. Direct PWM control eliminates D-to-A and A-to-D conversion delays and noise, allowing higher gains for more robust and responsive tuning without sacrificing stability.

All configurations provide these power-stage features:

- Direct operation off AC power mains (100 – 240 or 300 – 480 VAC, 50/60 Hz) or optional DC power input (24 – 350 or 24 – 700 VDC)
- Integrated bus power supply including soft start and shunt regulator (external resistor required)
- Separate 24VDC input to power logic circuitry
- Complete protection: over voltage, under voltage, over temperature, PWM frequency limit, minimum dead time, motor over temperature, short circuit, over current, input line monitor
- Ability to drive brushed and brushless permanent-magnet servo motors, or AC induction motors
- Single-digit LED display and six discrete LEDs for status information
- Optional safety relay circuitry. Please contact factory for more details and pricing.
- Easy setup with Turbo PMAC and UMAC controllers.

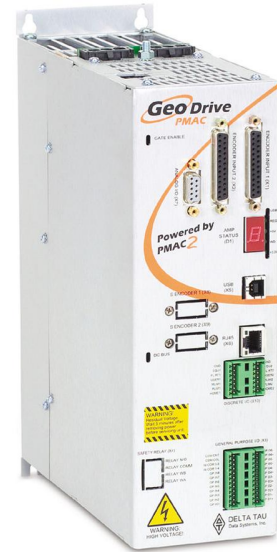

User Interface

The Geo Drive family is available in different versions distinguished by their user interface styles.

Geo MACRO Drives

The Geo MACRO Drive interfaces to the controller through the 125 Mbit/sec MACRO ring, with either a fiber-optic or Ethernet electrical medium, accepting numerical command values for direct PWM voltages and returning numerical feedback values for phase current, motor position, and status. It accepts many types of position feedback to the master controller, as well as axis flags (limits, home, and user) and general-purpose analog and digital I/O. Typically, the Geo MACRO Drives are commanded by either a PMAC2 Ultralite bus-expansion board, or a UMAC rack-mounted controller with a MACRO-interface card. This provides a highly distributed hardware solution, greatly simplifying system wiring, while maintaining a highly centralized software solution, keeping system programming simple.

- Choices for main feedback for each axis: A/B quadrature encoder, sinusoidal encoder with EnDat™ or Hiperface™, SSI encoder, resolver
- Secondary A/B quadrature encoder for each axis

- General-purpose isolated digital I/O: 4 in, 4 out at 24VDC
- 2 optional A/D converters, 12- or 16-bit resolution

Geo Direct-PWM Drives

The direct-PWM interface versions accept the actual power-transistor on/off signals from the PMAC2 controller, while providing digital phase-current feedback and drive status to the controller for closed-loop operation. Interface to the direct-PWM amplifier is through a standard 36-pin Mini-D style cable. The drive performs no control functions but has protection features. Drive installation, maintenance, and replacement are simplified because there is less wiring (position feedback and I/O are not connected to the drive) and there are no variables to set or programs to install in the drive.

- Fully centralized control means that all gains and settings are made in the PMAC; no software setup of drive is required
- No position feedback or axis flags required at the drive

Geo PMAC Drives

The Geo PMAC Drive is a standalone-capable integrated controller/amplifier with a built-in full PMAC2 controller having stored-program capability. It can be operated standalone, or commanded from a host computer through USB2.0 or 100 Mbps Ethernet ports. The controller has the full software capabilities of a PMAC (see descriptions), with an internal fully-digital connection to the advanced Geo power-stage, providing a convenient, compact, and cost-effective installation for one and two-axis systems, with easy synchronization to other drives and controls.

- Choices for main feedback for each axis: A/B quadrature encoder, sinusoidal encoder with EnDat™ or Hiperface™, SSI encoder, resolver
- Secondary A/B quadrature encoder for each axis
- General-purpose isolated digital I/O: 8 in, 6 out at 24VDC
- 2 optional A/D converters 12- or 16-bit resolution

Motion Controller Standard Features:

- Motorola DSP 56k digital signal processor
- PMAC2 CPU
- Fully Configurable via USB2.0 and Ethernet TCP/IP
- Operation from a PC via setup software
- Stand-alone operation
- Linear and circular interpolation
- 256 motion programs capacity
- 64 asynchronous PLC program capability
- Rotating buffer for large programs
- 36-bit position range (± 64 billion counts)
- Adjustable S-curve acceleration and deceleration
- Cubic trajectory calculations, splines
- Set and change parameters in real time
- Torque, Velocity and Position control standard
- Full rated temperature cooling standard (no need for additional fans except small power models)

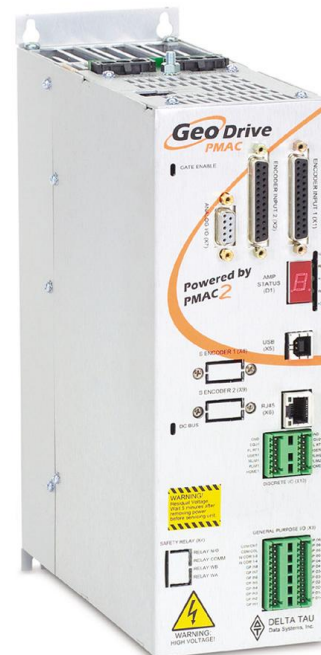

- Eight inputs @12-24V, fully-protected and isolated with separate commons for two banks of four.
- Six thermal-fuse protected outputs rated for 0.5A @, 24VDC each. (Flexible outputs allow for sinking or sourcing of current depending on whether the common emitter or common collector is used.)
- On single axis drives: One primary encoder with TTL differential/single-ended inputs with A, B quadrature channels and C index channel, 10 MHz cycle rate, or SSI feedback and Hall-effect inputs. Plus one secondary encoder with TTL differential/single-ended input with A, B quadrature feedback
- On two axis drives: Two primary encoders with TTL differential/single-ended inputs with A, B quadrature channels and C index channel, 10 MHz cycle rate, or SSI feedback and Hall-effect inputs, plus two secondary encoders with TTL differential/single-ended input with A, B quadrature feedback for Axis 1 and 2.
- Four flags per axis: HOME, PLIM, MLIM, and USER inputs; EQU compare output per axis.

Amplifier Standard Features:

- Direct Line Connections: models for either 240VAC or 480VAC, single or three phases
- DC operation from 24VDC to 740VDC
- Designed for UL and CE Certification (approval pending)
- Small footprint saves space.
- Dual-axis configurations are more economical and save panel space and installation wiring
- Complete protection: over voltage, under voltage, over temperature, motor over temperature, short circuit, over current, motor over temperature, input phase loss detection, shunt over-current detection.
- Integrated bus power supply including shunt regulator (external resistor required)
- Full ratings to 45°C ambient.

Optional Features:

- Resolvers or sine/cosine interpolator with Options 1 or 4
- Absolute encoder Inputs, Endat, Hiperface, SSI, with Options 2 or 5
- Two 16-bit analog-to-digital converter inputs, +/-10VDC, included with Options 3, 4 or 5.
- One differential 12-bit filtered PWM analog output, +/- 10V, included with Options 3, 4 or 5.
- Modbus Ethernet Connection, with Option M, special firmware.

Feedback Devices

Many motors incorporate a position feedback device. Devices are incremental encoders, resolvers, and sine encoder systems. The PMAC2 version of the Geo drive accepts feedback. In its standard form, it is set up to accept incremental encoder feedback and SSI encoders (one at a time). With the appropriate option, it is possible to use either resolver or sinusoidal encoder feedback. Historically, the choice of a feedback device has been guided largely by cost and robustness. Today, feedbacks are relatively constant for the cost and picked by features such as size and feedback data. More feedback data or resolution provides the opportunity to have higher gains in a servo system.

Geo PMAC drives have standard Secondary quadrature encoder feedback. One secondary encoder (X8) for one axis Drive and two secondary encoders (X8 and X9) for dual axis Drives.

Compatible Motors

The Geo drive product line is capable of interfacing to a wide variety of motors. The Geo drive can control almost any type of three-phase brushless motor, including DC brushless rotary, AC brushless rotary, induction, and brushless linear motors. Permanent magnet DC brush motors can also be controlled using two of the amplifiers three phases. Motor selection for an application is a science in itself and cannot be covered in this manual. However, some basic considerations and guidelines are offered. Motor manufacturers include a host of parameters to describe their motor.

Some basic equations can help guide an applications engineer to mate a proper drive with a motor. A

typical application accelerates a load to a speed, running the speed for a while and then decelerating the load back into position.

Maximum Speed

The motor's maximum rated speed is given. This speed may or may not be achievable in a given system. The speed could be achieved if enough voltage and enough current loop gain are available. In addition, consider the motor's feedback adding limitations to achievable speeds. The load attached to the motor also limits the maximum achievable speed. In addition, some manufacturers will provide motor data with their drive controller, which is tweaked to extend the operation range that other controllers may be able to provide. In general, the maximum speed can be determined by input voltage line-to-line divided by K_b (the motor's back EMF constant). It is wise to de-rate this a little for proper servo applications.

Torque

The torque required for the application can be viewed as both instantaneous and average. Typically, the instantaneous or peak torque is calculated as a sum of machining forces or frictional forces plus the forces required to accelerate the load inertia. The machining or frictional forces on a machine must be determined by the actual application. The energy required to accelerate the inertia follows the equation: $T = JA$, where T is the torque in Newton-meters or pound-feet required for the acceleration, J is the inertia in kilogram-meters-squared or pound-feet-second squared, and A is in radians per second per second. The required torque can be calculated if the desired acceleration rate and the load inertia reflected back to the motor are known. The $T=JA$ equation requires that the motor's inertia be considered as part of the inertia-requiring torque to accelerate.

Once the torque is determined, the motor's specification sheet can be reviewed for its torque constant parameter (K_t). The torque required at the application divided by the K_t of the motor provides the peak current required by the amplifier. A little extra room should be given to this parameter to allow for good servo control.

Most applications have a duty cycle in which the acceleration profile occurs repetitively over time. Calculating the average value of this profile gives the continuous rating required by the amplifier. Applications also concern themselves with the ability to achieve a speed. The requirements can be reviewed by either defining what the input voltage is to the drive, or defining what the voltage requirements are at the motor. Typically, a system is designed at a 230 or 480V input line. The motor must be able to achieve the desired speed with this voltage limitation. This can be determined by using the voltage constant of the motor (K_b), usually specified in volts-per-thousand rpm. The application speed is divided by 1000 and multiplied by the motor's K_b . This is the required voltage to drive the motor to the desired velocity. Headroom of 20% is suggested to allow for good servo control.

Peak Torque

The peak torque rating of a motor is the maximum achievable output torque. It requires that the amplifier driving it be able to output enough current to achieve this. Many drive systems offer a 3:1 peak-to-continuous rating on the motor, while the amplifier has a 2:1 rating. To achieve the peak torque, the drive must be sized to be able to deliver the current to the motor. The required current is often stated on the datasheet as the peak current through the motor. In some sense, it can also be determined by dividing the peak amplifier's output rating by the motor's torque constant (K_t).

Continuous Torque

The continuous torque rating of the motor is defined by a thermal limit. If more torque is consumed from the motor than this on average, the motor overheats. Again, the continuous torque output of the motor is subject to the drive amplifier's ability to deliver that current. The current is determined by the manufacturer's datasheets stating the continuous RMS current rating of the motor and can also be determined by using the motor's K_t parameter, usually specified in torque output per amp of input current.

Motor Poles

Usually, the number of poles in the motor is not a concern to the actual application. However, it should be noted that each pole-pair of the motor requires an electrical cycle. High-speed motors with high motor pole counts can require high fundamental drive frequencies that a drive amplifier may or may not be able to output. In general, drive manufacturers with PWM switching frequencies (16kHz or below) would like to see commutation frequencies less than 400 Hz. The commutation frequency is directly related to the number of poles in the motor.

Motor Inductance

PWM outputs require significant motor inductance to turn the on-off voltage signals into relatively smooth current flow with small ripple. Typically, motor inductance of servomotors is 1 to 15 mH. The Geo drive product series can drive this range easily. On lower-inductance motors (below 1mH), problems occur due to PWM switching where large ripple currents flow through the motor, causing excessive energy waste and heating. If an application requires a motor of less than 1mH, external inductors are recommended to increase that inductance. Motors with inductance in excess of 15mH can still be driven, but are slow to react and typically are out of the range of high performance servomotors.

Motor Resistance

Motor resistance is not really a factor in determining the drive performance, but rather, comes into play more with the achievable torque or output horsepower from the motor. The basic resistance shows up in the manufacturer's motor horsepower curve.

Motor Back EMF

The back EMF of the motor is the voltage that it generates as it rotates. This voltage subtracts from the bus voltage of the drive and reduces the ability to push current through the motor. Typical back EMF ratings for servomotors are in the area of 8 to 200 volts-per-thousand rpm. The Geo drive product series can drive any range of back EMF motor, but the back EMF is highly related to the other parameters of the motor such as the motor inductance and the motor K_t . It is the back EMF of the motor that limits the maximum achievable speed and the maximum horsepower capability of the motor.

Motor Torque Constant

Motor torque constant is referred to as K_t and usually it is specified in torque-per-amp. It is this number that is most important for motor sizing. When the load that the motor will see and knowing the motor's torque constant is known, the drive amplifier requirements can be calculated to effectively size a drive amplifier for a given motor. Some motor designs allow K_t to be non-linear, in which K_t will actually produce less torque per unit of current at higher output speeds. It is wise to de-rate the systems torque producing capability by 20% to allow headroom for servo control.

Motor Inertia

Motor inertia comes into play with motor sizing because torque to accelerate the inertia of the motor is effectively wasted energy. Low inertia motors allow for quicker acceleration. However, consider the reflected inertia from the load back to the motor shaft when choosing the motor's inertia. A high ratio of load-to-motor inertia can limit the achievable gains in an application if there is compliance in the transmission system such as belt-drive systems or rubber-based couplings to the systems. The closer the rotor inertia matches the load's reflected inertia to the motor shaft, the higher the achievable gains will be for a given system. In general, the higher the motor inertia, the more stable the system will be inherently. Mechanical gearing is often placed between the load and the motor simply to reduce the reflected inertia back to the motor shaft.

Motor Cabling

Motor cables are an integral part of a motor drive system. Several factors should be considered when selecting motor cables. First, the PWM frequency of the drive emits electrical noise. Motor cables must have a good-quality shield around them. The motor frame must also have a separate conductor to bring

back to the drive amplifier to help quench current flows from the motor due to the PWM switching noise. Both motor drain wire and the cable shield should be tied at both ends to the motor and to the drive amplifier.

Another consideration in selecting motor cables is the conductor-to-conductor capacitance rating of the cable. Small capacitance is desirable. Longer runs of motor cable can add motor capacitance loading to the drive amplifier causing undesired spikes of current. It can also cause couplings of the PWM noise into the earth grounds, causing excessive noise as well. Typical motor cable ratings would be 50 pf per foot maximum cable capacitance.

Another factor in picking motor cables is the actual conductor cross-sectional area. This refers to the conductor's ability to carry the required current to and from the motor. When calculating the required cable dimensions, consider agency requirements, safety requirements, maximum temperature that the cable will be exposed to, the continuous current flow through the motor, and the peak current flow through the motor. Typically, it is not suggested that any motor cable be less than 14 AWG.

The motor cable's length must be considered as part of the application. Motor cable length affects the system in two ways. First, additional length results in additional capacitive loading to the drive. The drive's capacitive loading should be kept to no more than 1000pf. Additionally, the length sets up standing waves in the cable, which can cause excessive voltage at the motor terminals. Typical motor cable length runs up to 60 meters (200 feet) for 230V systems and 15 meters (50 feet) for 480V systems are acceptable. Exceeding these lengths may put other system requirements in place for either a snubber at the motor end or a series inductor at the drive end. The series inductor at the drive end provides capacitance loading isolation from the drive and slows the rise time of the PWM signal into the cable, resulting in less voltage overshoot at the motor.

SPECIFICATIONS

Part Number

Geo PMAC Drive Model Number Definition

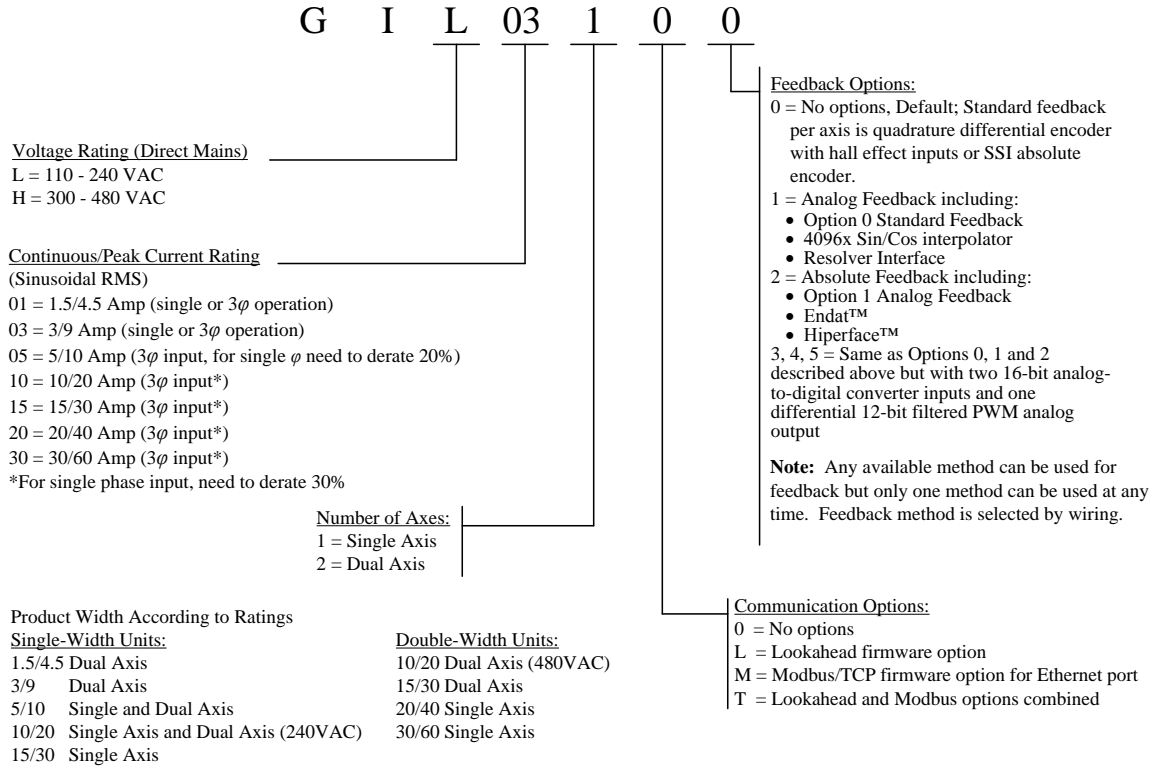

		Glx012xx	Glx051xx	Glx101xx	Glx151xx	Glx032xx	Glx052xx	GIL102xx	Glx201xx	Glx301xx	GHI102xx	Glx152xx
Axis	Single axis		√	√	√				√	√		
	Dual Axis	√				√	√	√			√	√
Sizing	Low Profile	√										
	Single Width		√	√	√	√	√	√				
	Double Width								√	√	√	√

Geo PMAC Feedback Options

Model	Default Configuration: Quadrature Encoders, or SSI Absolute Encoders and Hall Effect inputs	Analog (Sin/Cos) Encoders: x4096 Interpolator Resolver to Digital Converters	Absolute Encoder Interface: Endat Hiperface	Addition of two channels of 16-bit A/D converters with each feedback option and one 12-bit filtered PWM- DAC output
GIxxxxx0	√			
GIxxxxx1		√		
GIxxxxx2			√	
GIxxxxx3	√			√
GIxxxxx4		√		√
GIxxxxx5			√	√
GIxxxxLx	Lookahead firmware option			
GIxxxxMx	Ethernet Modbus TCP			
GIxxxxTx	Combination of Lookahead option and Modbus			

Package Types

Geo package types provide various power levels and one or two axis capability with three different package types.

The Geo Drive has a basic package size of 3.3"W x 9.875"H x 8.0"D (84mm W x 251mm H x 203mm D). This size includes the heat sink and fan. In this package size, Single Width, the Geo can handle one or two low-to-medium power axes OR only a single axis for medium to high power.

The mechanical design of the Geo drive is such that it allows two heat sinks to be easily attached together so as to provide two high power axes in a Double Width configuration. This double package size is 6.5" W x 9.875" H x 8.0" D (165 mm W x 251 mm H x 203 mm D). It provides a highly efficient package size containing two axes of up to about 10kW each thus driving nearly 24kW of power, but using a single interface card. This results in a highly cost efficient package.

There is also one more package type only for the low power (1.5A/4.5A) single width Geo drive, model GIx012xx. This package substitutes the heatsink and the fan with a smaller plate which has the same mounting pattern with the regular single width drive making the unit's depth 2.2 inches (56 mm) less than the single width drive, 5.8" D.

- Low Profile: GIx012xx (only)**
 3.3" wide (84 mm) (no heatsink, no fan), Maximum Power Handling ~1200 watts
 Package Dimensions: 3.3" W x 9.875" H x 5.8" D (84 mm W x 251 mm H x 148 mm D)
 Weight: 4.3lbs. (1.95kgs)
- Single Width: GIx051xx, GIx101xx, GIx151xx, GIH032xx, GIx052xx and GIL102xx**
 3.3" wide (84 mm)(with heatsink and fan), Maximum Power Handling ~12000 watts
GIL032xx Single Width, with heatsink, no Fan (Weight 5.4lbs/2.45kgs)
 Package Dimensions: 3.3" W x 9.875" H x 8.0" D (84 mm W x 251 mm H x 203 mm D)
 Weight: 5.5lbs. (2.50kgs)
- Double Width: GIx201xx, GIx301xx, GIH102xx and GIx152xx.**
 6.5" wide (164mm) (with heatsink and fan), Maximum Power Handling ~24,000 watts
 Package Dimensions: 6.5" W x 9.875" H x 8.0" D (164mm W x 251 mm H x 203 mm D)
 Weight: 11.6lbs (5.3kgs)

Electrical Specifications

240VAC Input Drives		GxL051	GxL101	GxL151	GxL201	GxL301
Main Input Power	Nominal Input Voltage (VAC)	230				
	Rated Input Voltage (VAC)	97-265				
	Rated Continuous Input Current (A $A_{C_{RMS}}$)	3.3	6.6	9.9	13.2	19.8
	Rated Input Power (Watts)	1315	2629	3944	5259	7888
	Frequency (Hz)	50/60				
	Phase Requirements	1 Φ or 3 Φ	3 Φ			
	Charge Peak Inrush Current (A)					
	Main Bus Capacitance (μ f)	3380		5020	6800	
Output Power	Rated Output Voltage (V)	138				
	Rated Cont. Output Current per Axis	5	10	15	20	30
	Peak Output Current (A) for 2 seconds	10	20	30	40	60
	Rated Output Power per Axis (Watts)	1195	2390	3585	4780	7171
Bus Protection	Nominal DC Bus	325				
	Over-voltage Trip Level (VDC)	410				
	Under-voltage Lockout Level (VDC)	10				
Shunt Regulator Ratings	Turn-On Voltage (VDC)	392				
	Turn-Off Voltage (VDC)	372				
	Delta Tau Recommended Load Resistor (300 W Max.)	GAR78	GAR48		GAR48-3	
Control Logic Power	Input Voltage (VDC)	20-27				
	Input Current (A)	2A				
	Inrush Current (A)	4A				
Current Feedback	Resolution (bits)	12				
	Full-scale Signed Reading (\pm A)	16.26	32.53	48.79	65.05	97.58
Transistor Control	Delta Tau Recommended PWM Frequency (kHz) @rated current	12		10	8	
	Minimum Dead Time (μ s)	1				
	Charge Pump Time (% of PWM period.)	5				

Note:

All values at ambient temperature of 0-45°C (113F) unless otherwise stated.

		GxL012	GxL032	GxL052	GxL102	GxL152
Main Input Power	Output Circuits (axes)	2				
	Nominal Input Voltage (VAC)	230				
	Rated Input Voltage (VAC)	97-265				
	Rated Continuous Input Current (A AC _{RMS})	1.98	3.96	6.6	13.2	19.8
	Rated Input Power (Watts)	789	1578	2629	5259	7888
	Frequency (Hz)	50/60				
	Phase Requirements	1Φ or 3Φ	1Φ or 3Φ	3Φ		
	Charge Peak Inrush Current (A)					
Main Bus Capacitance (μf)	3380				5020	
Output Power	Rated Output Voltage (V)	138				
	Rated Cont. Output Current per Axis	1.5	3	5	10	15
	Peak Output Current (A) for 2 seconds	4.5	9	10	20	30
	Rated Output Power per Axis (Watts)	359	717	1195	2390	3585
Bus Protection	Nominal DC Bus	325				
	Over-voltage Trip Level (VDC)	410				
	Under-voltage Lockout Level (VDC)	10				
Shunt Regulator Ratings	Turn-On Voltage (VDC)	392				
	Turn-Off Voltage (VDC)	372				
	Delta Tau Recommended Load Resistor (300 W Max.)	GAR78			GAR48	
Control Logic Power	Input Voltage (VDC)	20-27				
	Input Current (A)	2A				
	Inrush Current (A)	4A				
Current Feedback	Resolution (bits)	12				
	Full-scale Signed Reading (±A)	7.32	14.64	16.26	32.53	48.79
Transistor Control	Delta Tau Recommended PWM Frequency (kHz)	16		12		10
	Minimum Dead Time (μs)	1				
	Charge Pump Time (% of PWM period.)	5				

Note:

All values at ambient temperature of 0-45°C (113F) unless otherwise stated.

480VAC Input Drives		GxH051	GxH101	GxH151	GxH201	GxH301
	Output Circuits (axes)	1				
Main Input Power	Nominal Input Voltage (VAC)	480				
	Rated Input Voltage (VAC)	300-525				
	Rated Continuous Input Current (A AC_{RMS})	3.3	6.6	9.9	13.2	19.8
	Rated Input Power (Watts)	2744	5487	8231	10974	16461
	Frequency (Hz)	50/60				
	Phase Requirements	1 Φ or 3 Φ	3 Φ			
	Charge Peak Inrush Current (A)					
	Main Bus Capacitance (μ f)	845		1255		1700
	Rated Output Voltage (V) @ Rated Current	288				
	Rated Cont. Output Current per Axis	5	10	15	20	30
	Peak Output Current (A) for 2 seconds	10	20	30	40	60
	Rated Output Power per Axis (Watts)	2494	4988	7482	9977	14965
Bus Protection	Nominal DC Bus	678				
	Over-voltage Trip Level (VDC)	828				
	Under-voltage Lockout Level (VDC)	20				
Shunt Regulator Ratings	Turn-On Voltage (VDC)	784				
	Turn-Off Voltage (VDC)	744				
	Delta Tau Recommended Load Resistor (300 W Max.)	GAR78	GAR48		GAR48-3	
Control Logic Power	Input Voltage (VDC)	20-27				
	Input Current (A)	2A				
	Inrush Current (A)	4A				
Current Feedback	Resolution (bits)	12				
	Full-scale Signed Reading (\pm Amperes)	16.26	32.53	48.79	65.05	97.58
Transistor Control	Delta Tau Recommended PWM Frequency (KHz) @ rated current	12	10	8		
	Minimum Dead Time (μ s)	1.6				
	Charge Pump Time (% of PWM period.)	5				

		GxH012	GxH032	GxH052	GxH102	GxH152
Main Input Power	Output Circuits (axes)	2				
	Nominal Input Voltage (VAC)	480				
	Rated Input Voltage (VAC)	300-525				
	Rated Continuous Input Current (A AC _{RMS})	1.98	3.96	6.6	13.2	19.8
	Rated Input Power (Watts)	1646	3292	5487	10974	16461
	Frequency (Hz)	50/60				
	Phase Requirements	1Φ or 3Φ		3Φ		
	Charge Peak Inrush Current (A)					
Main Bus Capacitance (μf)	845				1255	
	Rated Output Voltage (V) @ Rated Current	288				
	Rated Cont. Output Current per Axis	1.5	3	5	10	15
	Peak Output Current (A) for 2 seconds	4.5	9	10	20	30
	Rated Output Power per Axis (Watts)	748	1496	2494	4988	7482
Bus Protection	Nominal DC Bus	678				
	Over-voltage Trip Level (VDC)	828				
	Under-voltage Lockout Level (VDC)	20				
Shunt Regulator Ratings	Turn-On Voltage (VDC)	784				
	Turn-Off Voltage (VDC)	744				
	Delta Tau Recommended Load Resistor (300 W Max.)	GAR78			GAR48	
Control Logic Power	Input Voltage (VDC)	20-27				
	Input Current (A)	2A				
	Inrush Current (A)	4A				
Current Feedback	Resolution (bits)	12				
	Full-scale Signed Reading (±Amperes)	7.32	14.64	16.26	32.53	48.79
Transistor Control	Delta Tau Recommended PWM Frequency (KHz) @ rated current	12		10	8	
	Minimum Dead Time (μs)	1.6				
	Charge Pump Time (% of PWM period.)	5				

Note:

All values at ambient temperature of 0-45°C (113F) unless otherwise stated.

Environmental Specifications

Description	Unit	Specifications
Operating Temperature	°C	+0 to 45 (113F). Above 45°C, de-rate the continuous peak output current by 2.5% per °C above 45°C. Maximum Ambient is 55°C (131F).
Rated Storage Temperature	°C	-25 to +70
Humidity	%	10% to 90% non-condensing
Shock		Call Factory
Vibration		Call Factory
Operating Altitude	Feet (Meters)	To 3300 feet (1000 meters). De-rate the continuous and peak output current by 1.1% for each 330 feet (100 meters) above the 3300 feet
Air Flow Clearances	in (mm)	3" (76.2mm) above and below unit for air flow

Recommended Fusing and Wire Gauge

Model	Recommended Fuse (FRN/LPN)	Recommended Wire Gauge*
GIL012xx	15	14 AWG
GIL032xx	20	12 AWG
GIL051xx	20	12 AWG
GIL052xx	20	12 AWG
GIL101xx	20	12 AWG
GIL102xx	20	12 AWG
GIL151xx	25	10 AWG
GIL152xx	25	10 AWG
GIL201xx	25	10 AWG
GIL301xx	30	8 AWG
GIH012xx	15	14 AWG
GIH032xx	20	12 AWG
GIH051xx	20	12 AWG
GIH052xx	20	12 AWG
GIH101xx	20	12 AWG
GIH102xx	20	12 AWG
GIH151xx	25	10 AWG
GIH152xx	25	10 AWG
GIH201xx	25	10 AWG
GIH301xx	30	8 AWG

* See local and national code requirements

Wire Sizes

Geo Drive electronics create a DC bus by rectifying the incoming AC electricity. The current flow into the drive is not sinusoidal but rather a series of narrow, high-peak pulses. Keep the incoming impedance small to not hinder these current pulses. Conductor size, transformer size, and fuse size recommendations may seem larger than normally expected. All ground conductors should be 8AWG minimum using wires constructed of many strands of small gauge wire. This provides the lowest impedance to high-frequency noises.

RECEIVING AND UNPACKING

Delta Tau products are thoroughly tested at the factory and carefully packaged for shipment. When the Geo Drive is received, do the following immediately.

1. Observe the condition of the shipping container and report any damage immediately to the commercial carrier that delivered the drive.
2. Remove the drive from the shipping container and remove all packing materials. Check all shipping material for connector kits, documentation, diskettes, CD ROM, or other small pieces of equipment. Be aware that some connector kits and other equipment pieces may be quite small and can be accidentally discarded if care is not used when unpacking the equipment. The container and packing materials may be retained for future shipment.
3. Verify that the part number of the drive received is the same as the part number listed on the purchase order.
4. Inspect the drive for external physical damage that may have been sustained during shipment and report any damage immediately to the commercial carrier that delivered the controller.
5. Electronic components in this amplifier are design-hardened to reduce static sensitivity. However, use proper procedures when handling the equipment.
6. If the Geo Drive is to be stored for several weeks before use, be sure that it is stored in a location that conforms to published storage humidity and temperature specifications stated in this manual.

Use of Equipment

The following guidelines describe the restrictions for proper use of the Geo Drive:

- The components built into electrical equipment or machines can be used only as integral components of such equipment.
- The Geo Drives are to be used only on grounded three-phase industrial mains supply networks (TN-system, TT-system with grounded neutral point).
- The Geo Drives must not be operated on power supply networks without a ground or with an asymmetrical ground.
- If the Geo Drives are used in residential areas, or in business or commercial premises, implement additional filter measures.
- The Geo Drives may be operated only in a closed switchgear cabinet, taking into account the ambient conditions defined in the environmental specifications.

Delta Tau guarantees the conformance of the Geo Drives with the standards for industrial areas stated in this manual, only if Delta Tau components (cables, controllers, etc.) are used.

Geo PMAC drive is a combination of a PMAC2 controller and Geo Amplifier. So parallel with this manual the user needs to use the PMAC1/2 Software reference manual and the PMAC USERS manual.

Note:

Always download the latest manual revision from the Delta Tau website

www.deltatau.com

Note:

If Ethernet communications is used, Delta Tau Systems strongly recommends use of RJ45 CAT5e or better shielded cable.

Newer network cards have the Auto-MDIX feature that eliminates the need for crossover cabling by performing an internal crossover when a straight cable is detected during the auto-negotiation process.

For older network cards, one end of the link must perform media dependent interface (MDI) crossover (MDIX), so that the transmitter on one end of the data link is connected to the receiver on the other end of the data link (a crossover/patch cable is typically used). If an RJ45 hub is used, then a regular straight cable must be implemented..

Maximum length for Ethernet cable should not exceed 100m (330ft).

MOUNTING

The location of the control is important. Installation should be in an area that is protected from direct sunlight, corrosives, harmful gases or liquids, dust, metallic particles, and other contaminants. Exposure to these can reduce the operating life and degrade performance of the control.

Several other factors should be evaluated carefully when selecting a location for installation:

- For effective cooling and maintenance, the control should be mounted on a smooth, non-flammable vertical surface.
- At least 3 inches (76mm) top and bottom clearance must be provided for airflow. At least 0.4 inches (10mm) clearance is required between controls (each side).
- Temperature, humidity and Vibration specifications should also be taken in account.

The Geo Drives can be mounted with a traditional 4-hole panel mount, two U shape/notches on the bottom and two pear shaped holes on top. This keeps the heat sink and fan (single width and double width drives), inside the mounting enclosure. On the low profile units (low power), the heat sink and fan are replaced with a flat plate, and use the mounting enclosure itself as a heat sink and reduce the depth of the Geo amplifier by about 2.2 inches (~56 mm) to a slim 5.8 inch D (150 mm D). Mounting is also identical to the single and double width drives through the 4-hole panel mount.

If multiple Geo drives are used, they can be mounted side-by-side, leaving at least a 0.4inch clearance between drives. This means a 3.7 inch center-to-center distance (94 mm) with the Single width and low profile Geo drives. Double Width Geo amplifiers can be mounted side by side at 6.9 inch center-to-center distance (175 mm).

It is extremely important that the airflow is not obstructed by the placement of conduit tracks or other devices in the enclosure.

The drive is mounted to a back panel. The back panel should be unpainted and electrically conductive to allow for reduced electrical noise interference. The back panel should be machined to accept the mounting bolt pattern of the drive. Make sure that all metal chips are cleaned up before the drive is mounted so there is no risk of getting metal chips inside the drive.

The drive is mounted to the back panel with four M4 screws and internal-tooth lock washers. It is important that the teeth break through any anodization on the drive's mounting gears to provide a good electrically conductive path in as many places as possible. Mount the drive on the back panel so there is airflow at both the top and bottom areas of the drive (at least three inches).

Caution:

Units must be installed in an enclosure that meets the environmental IP rating of the end product (ventilation or cooling may be necessary to prevent enclosure ambient from exceeding 45° C [113° F]).

The figures below show the mounting dimensions of the drives.

Note:

For more detail drawings (SolidWorks, eDrawings, DXF) visit our website under the product that you are looking for.

Low Profile

GIX012XX (only)

Geo PMAC Low Profile, Dual Axis (Without Heatsink, Without Fan) GIL012XX, GIH012XX

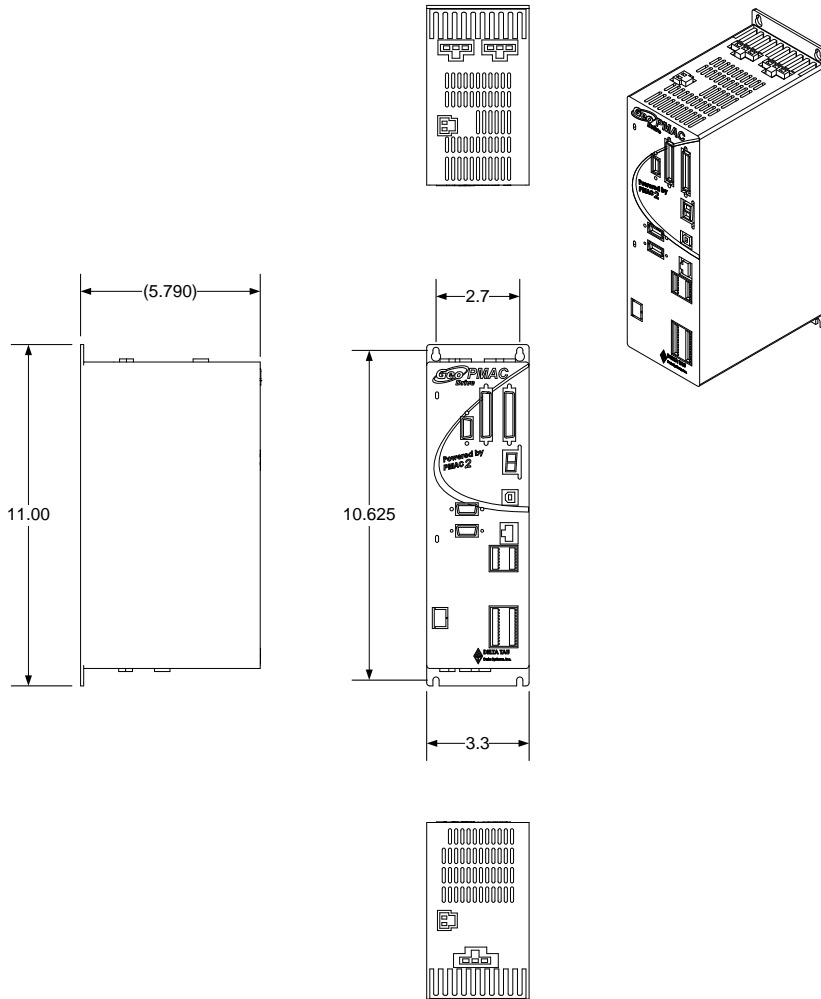

Single Width

GIx051xx, GIx101xx, GIx151xx, GIx032, GIx052xx, and GIL102xx

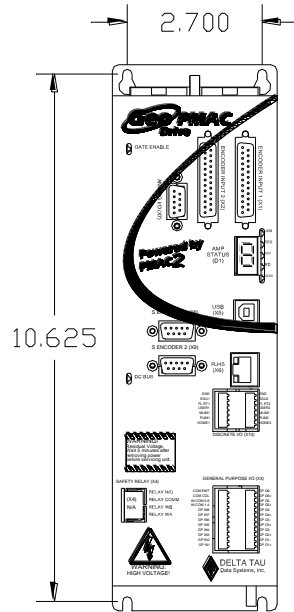
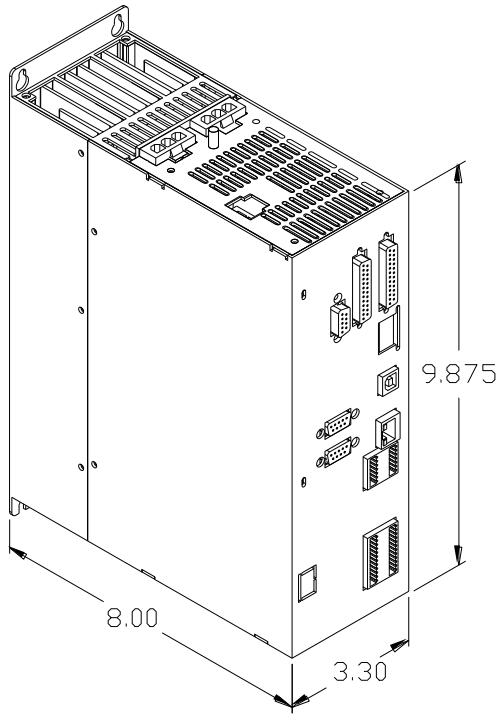

TOP VIEW

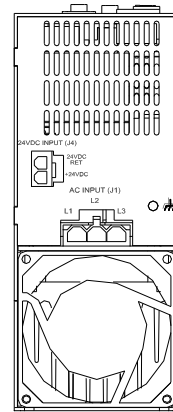
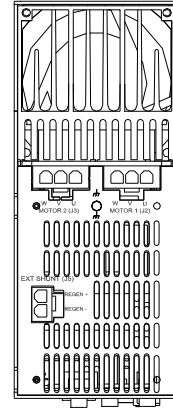

BOTTOM VIEW

Double Width

GIx201xx and GIx301xx (single axis), GIH102xx and GIx152xx (dual axis)

GIH102, GIL152 & GIH152
10.0/20.0 & 15.0/30.0 AMPS CONT/PEAK (306-603705)
PMAC Version, Internal Heatsink Mtg,
Double wide with 2 Fans

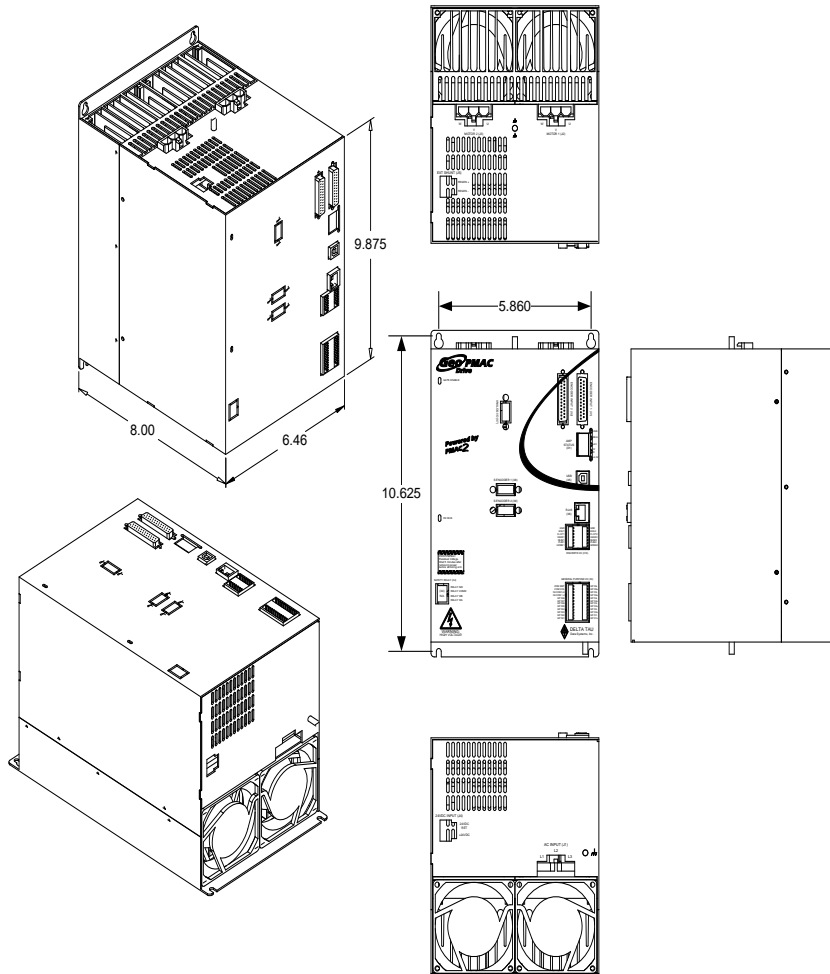

CONNECTIONS

System (Power) Wiring

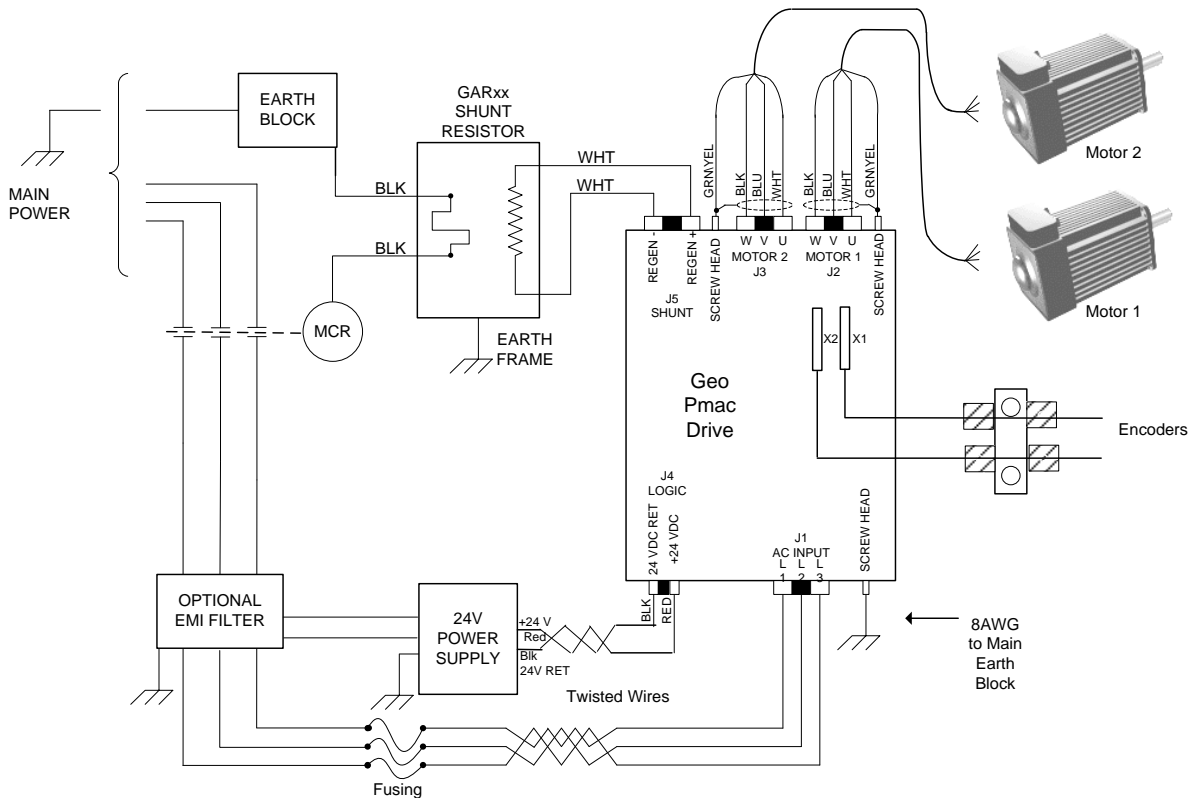

WARNING:

Installation of electrical control equipment is subject to many regulations including national, state, local, and industry guidelines and rules. General recommendations can be stated but it is important that the installation be carried out in accordance with all regulations pertaining to the installation.

Fuse and Circuit Breaker Selection

In general, fusing must be designed to protect the weakest link from fire hazard. Each Geo drive is designed to accept more than the recommended fuse ratings. External wiring to the drive may be the weakest link as the routing is less controlled than the drive's internal electronics. Therefore, external circuit protection, be it fuses or circuit breakers, must be designed to protect the lesser of the drive or external wiring.

High peak currents and high inrush currents demand the use of slow blow type fuses and hamper the use of circuit breakers with magnetic trip mechanisms. Generally, fuses are recommended to be larger than what the rms current ratings require. Remember that some drives allow three times the continuous rated current on up to two axis of motion. Time delay and overload rating of protection devices must consider this operation.

Use of GFI Breakers

Ground Fault Interrupter circuit breakers are designed to break the power circuit in the event that outgoing currents are not accompanied by equal and opposite returning currents. These breakers assume that if outgoing currents are not returning then there is a ground path in the load. Most circuit breakers of this type account for currents as low as 10mA PWM switching in servo drives coupled with parasitic capacitance to ground in motor windings and long cables generate ground leakage current. Careful installation practices must be followed. The use of inductor chokes in the output of the drive will help keep these leakage currents below breaker threshold levels.

Transformer and Filter Sizing

Incoming power design considerations for use with Geo Drives require some over rating. In general, it is recommended that all 3-phase systems using transformers and incoming filter chokes be allotted a 25% over size to keep the impedances of these inserted devices from affecting stated system performance. In general, it is recommended that all single-phase systems up to 1kW be designed for a 50% overload. All single-phase systems over 1kW should be designed for a 200% overload capacity.

Noise Problems

When problems do occur often it points to electrical noise as the source of the problem. When this occurs, turn to controlling high-frequency current paths. If following the grounding instructions does not work, insert chokes in the motor phases. These chokes can be as simple as several wraps of the individual motor leads through a ferrite ring core (such as Micrometals T400-26D). This adds high-frequency impedance to the outgoing motor cable thereby making it harder for high-frequency noise to leave the control cabinet area. Care should be taken to be certain that the core's temperature is in a reasonable range after installing such devices.

Operating Temperature

It is important that the ambient operating temperature of the Geo Drive be kept within specifications. The Geo Drive should be installed in an enclosure such as a NEMA cabinet. The internal temperature of the cabinet must be kept under the Geo Drive Ambient Temperature specifications. It is sometimes desirable to roughly calculate the heat generated by the devices in the cabinet to determine if some type of ventilation or air conditioning is required. For these calculations the Geo Drive's internal heat losses must be known. Budget 100W per axis for 1.5 amp drives, 150W per axis for 3 amp drives, 200W per axis for 5 amp drives, 375W per axis for 10 Amp drives, and 500W per axis for 15 Amp drives.

From 0°C to 45°C (113F) ambient, no de-rating required. Above 45°C, derate the continuous and peak output current by 2.5% per °C above 45°C. Maximum ambient is 55°C (131F).

Single Phase Operation

Due to the nature of power transfer physics, it is not recommended that any system design attempt to consume more than 2kW from any single-phase mains supply. Even this level requires careful considerations. The simple bridge rectifier front end of the Geo Drive, as with all other drives of this type, require high peak currents. Attempting to transfer power from a single-phase system getting one charging pulse each 8.3 milliseconds causes excessively high peak currents that can be limited by power mains impedances. The Geo Drive output voltage sags, the input rectifiers are stressed, and these current pulses cause power quality problems in other equipment connected to the same line. While it is possible to operate drives on single-phase power, the actual power delivered to the motor must be considered. Never design expecting more than 1.5 HP total from any 115V single-phase system and never more than 2.5 HP from any 230V single-phase system.

Wiring AC Input, J1

The main bus voltage supply is brought to the Geo drive through connector J1. 1.5A continuous and 3A continuous Geo drives can be run off single-phase power. It is acceptable to bring the single-phase power into any two of the three input pins on connector J1. Higher-power drive amplifiers require three-phase input power. It is extremely important to provide fuse protection or overload protection to the input power to the Geo drive amplifier. Typically, this is provided with fuses designed to be slow acting, such as FRN-type fuses. Due to the various regulations of local codes, NEC codes, UL and CE requirements, it is very important to reference these requirements before making a determination of how the input power is wired.

Additionally, many systems require that the power be able to be turned on and off in the cabinet. It is typical that the AC power is run through some kind of main control contact within the cabinet, through the fuses, and then fed to a Geo drive. If multiple Geo drives are used, it is important that each drive has its own separate fuse block.

Whether single- or three-phase, it is important that the AC input wires be twisted together to eliminate noise radiation as much as possible. Additionally, some applications may have further agency noise reduction requirements that require that these lines be fed from an input filtering network.

The AC connections from the fuse block to the Geo drive are made via a cable that is either purchased as an option from Delta Tau (CABKITxx) or made with the appropriate connector kit (CONKITxx). (Appendix A)

J1: AC Input Connector Pinout

Pin #	Symbol	Function	Description	Notes
1	L3	Input	Line Input Phase 3	
2	L2	Input	Line Input Phase 2	
3	L1	Input	Line Input Phase 1	(Not used for single Phase input)
On Gxx201xx and Gxx301xx, there is a fourth pin for GROUND connection. If DC bus is used, use L3 for DC+ and L2 for DC return. Connector is located at the bottom side of the unit				

Wiring Earth-Ground

Panel wiring requires that a central earth-ground location be installed at one part of the panel. This electrical ground connection allows for each device within the enclosure to have a separate wire brought back to the central wire location. The ground connection is usually a copper plate directly bonded to the back panel or a copper strip with multiple screw locations. The Geo drive is brought to the earth-ground via a wire connected to the M4 stud (5mm thread) on the top of the location through a heavy gauge, multi-strand conductor to the central earth-ground location. On some models, a fourth pin is provided on the 3-phase AC input connector (J1) and on the motor output connectors to provide a ground connection.

Earth Grounding Paths

High-frequency noises from the PWM controlled power stage will find a path back to the drive. It is best that the path for the high-frequency noises be controlled by careful installation practices. The major failure in problematic installations is the failure to recognize that wire conductors have impedances at high frequencies. What reads 0 ohms on a handheld meter may be hundreds of ohms at 30MHz.

Consider the following during installation planning:

1. Star point all ground connections. Each device wired to earth ground should have its own conductor brought directly back to the central earth ground plate.
2. Use unpainted back panels. This allows a wide area of contact for all metallic surfaces reducing high frequency impedances.
3. Conductors made up of many strands of fine conductors outperform solid or conductors with few

strands at high frequencies.

4. Motor cable shields should be bonded to the back panel using 360-degree clamps at the point they enter or exit the panel.
5. Motor shields are best grounded at both ends of the cable. Again, connectors using 360-degree shield clamps are superior to connector designs transporting the shield through a single pin. Always use metal shells.
6. Running motor armature cables with any other cable in a tray or conduit should be avoided. These cables can radiate high frequency noise and couple into other circuits.

Wiring 24 V Logic Control, J4

An external 24VDC power supply is required to power the logic portion of the Geo drive. This power can remain on, regardless of the main AC input power, allowing the signal electronics to be active while the main motor power control is inactive. The 24V is wired into connector J4. The polarity of this connection is extremely important. Carefully follow the instructions in the wiring diagram. This connection can be made using 16 AWG wire directly from a protected power supply. In situations where the power supply is shared with other devices, it may be desirable to insert a filter in this connection.

The power supply providing this 24V must be capable of providing an instantaneous current of at least 1.5A to be able to start the DC-to-DC converter in the Geo drive. In the case where multiple drives are driven from the same 24V supply, it is recommended that each drive be wired back to the power supply terminals independently. It is also recommended that the power supply be sized to handle the instantaneous inrush current required to start up the DC-to-DC converter in the Geo drive.

J4: 24VDC Input Logic Supply Connector

Pin #	Symbol	Function	Description	Notes
1	24VDC RET	Common	Control power return	
2	+24VDC	Input	Control power input	24V+/-10%, 2A

Connector is located at the bottom side of the unit

Wiring the Motors

The cable wiring must be shielded and have a separate conductor connecting the motor frame back to the drive amplifier. The cables are available in cable kits (CABKITxx) from Delta Tau (see Appendix A). Motor phases are conversed in one of three conventions. Motor manufacturers will call the motor phases A, B, or C. Other motor manufacturers call them U, V, W. Induction motor manufacturers may call them L1, L2, and L3. The drive's inputs are called U, V, and W. Wire U, A, or L1 to the drive's U terminal. Wire V, B, or L2 to the drive's V terminal. Wire W, C, or L3 to the drive's W terminal. The motor's frame drain wire and the motor cable shield must be tied together at the mounting stud (5mm thread) on top of the Geo drive product.

J2: Motor 1 Output Connector Pinout

Pin #	Symbol	Function	Description	Notes
1	U	Output	Axis 1 Phase1	
2	V	Output	Axis 1 Phase2	
3	W	Output	Axis 1 Phase3	

On Gxx201xx and Gxx301xx, there is a fourth pin for ground connection.
Connector is located at the top side of the unit, for Ground connection use the screw with a lug

J3: Motor 2 Output Connector Pinout (Optional)

Pin #	Symbol	Function	Description	Notes
1	U	Output	Axis 2 Phase1	2- Axis drives only
2	V	Output	Axis 2 Phase2	2- Axis drives only
3	W	Output	Axis 2 Phase3	2- Axis drives only

Connector is located at the top side of the unit, for Ground connection use the screw with a lug

Wiring the Motor Thermostats

Some motor manufacturers provide the motors with integrated thermostat overload detection capability. Typically, it is in one or two forms: a contact switch that is normally closed or a PTC. These sensors can be wired into the Geo drive's front panel at connector X1 and X2. Motor 1 thermostat output is wired to pin 23 of X1, **In_Therm_Mot1**, and referenced to the GND pin 13 or 25. In addition, if dual axis drive is ordered, Motor 2 thermostat output is wired to pin 23 of X2, **In_Therm_Mot2**, and referenced to the GND pin 13 or 25.

I1013 was specially created (firmware 1.17C and above) for Geo PMAC drives to enable the motor over-temperature function of the drive, default this function is disabled. If someone wants to enable the motor #1 temperature input switch to his Geo then he needs to set I1013=1. For motor #2 over-temperature input to be enabled I1013=2 and if the user wants both motor over-temperature inputs enable then I1013=3.

For earlier drives (firmware 1.17A and 1.17B) If the motor over-temperature protection is not required, In_Therm_Mot1/2 should be connected to GND, pin 13 or 25 of X1/X2 respectively. Otherwise, the drive status display will show a warning error code **5** for motor #1 over -temperature, or an **A** for motor #2 over-temperature. If both pins are not shorted to GND, display will show **5** (the first error that gets triggered).

On the right side there is an example on how the user could wire to the thermostats.

Function	Pin
Motor Thermostat Input	23
GND	13,25

Wiring the Motor Thermostats

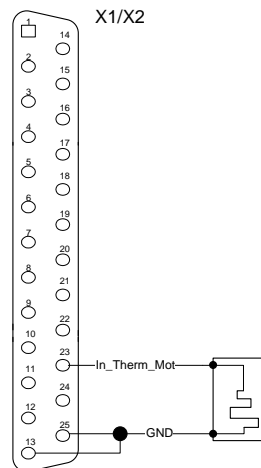

Wiring the Regen (Shunt) Resistor J5

The Geo Drive family offers compatible regen resistors as optional equipment. The regen resistor is used as a shunt regulator to dump excess power during demanding deceleration profiles. The GAR48 and GAR78 resistors are designed to dump the excess bus energy very quickly.

The regen circuit is also known as a shunt regulator. Its purpose is to dump power fed back into the drive from a motor acting as a generator. Excessive energy can be dumped via an external load resistor. The Geo product series is designed for operation with external shunt resistors of 48 Ω for the 10 and 15 amp versions or 78 Ω for the 1.5, 3, and 5 amp versions. These are available directly from Delta Tau as GAR48 and GAR78, respectively. These resistors are provided with pre-terminated cables that plug into connector J5.

Each resistor is the lowest ohm rating for its compatible drive and is limited for use to 200 watts RMS. There are times the regen design might be analyzed to determine if an external Regen resistor is required or what its ratings can be. The following data is provided for such purpose.

Caution:

The black wires are for the thermostat and the white wires are for the regen resistor on the external regen resistor (pictured below). These resistors can reach temperatures of up to 200 degrees C. These resistors must be mounted away from other devices and near the top of the cabinet. Additionally, precautions must be made to ensure the resistors are enclosed and cannot be touched during operation or anytime they are hot. Sufficient warning labels should be placed prominently near these resistors.

The GAR regen resistors incorporate a thermal overload protection thermostat that opens when the core temperature of the resistor exceeds 225 degrees C. This thermostat is available through the two black leads exiting the resistor. It is important that these two leads be wired in a safety circuit that stops the system from operating should the thermostat open.

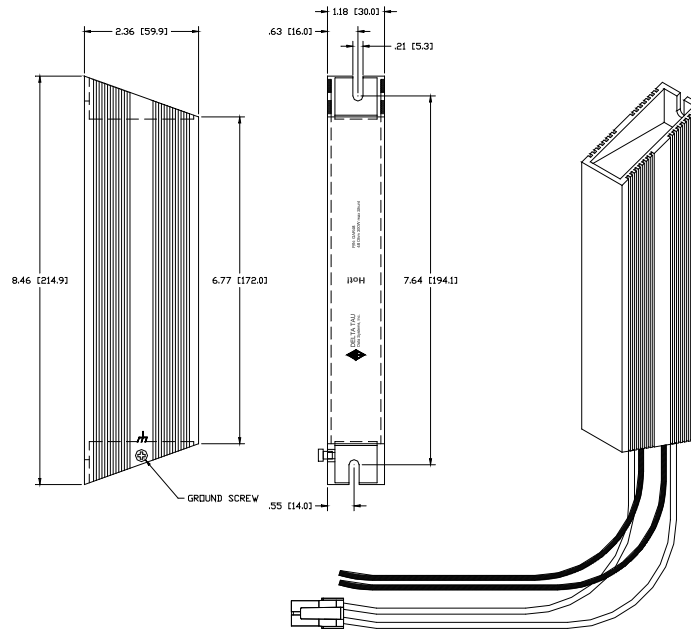

J5: External Shunt Connector Pinout

Pin #	Symbol	Function
1	Regen-	Output
2	Regen+	Output
Connector is located at the top side of the unit DT Connector part number #014-000F02-HSG and pins part number #014-043375-001 Molex Crimper tool p/n#63811-0400		
For the high Current Drives, Gxx201xx and Gxx301xx , this connector is a 3 pin Large Molex connector		
1	CAP-	Output
2	Regen-	Output
3	Regen+	Output
Connector is located at the top side of the unit. DT Connector part number #014-H00F03-049 and pins part number #014-042815-001. Molex Crimper tool p/n#63811-1500		

Shunt Regulation

When the motor is used to slow the moving load, this is called regenerative deceleration. Under this operation, the motor is acting as a generator consuming energy from the load while passing the energy into the DC Bus storage capacitors. Left unchecked, the DC Bus voltage can raise high enough to damage the drive. For this reason there are protection mechanisms built into the Geo Drive product such as shunt regulation and over-voltage protection.

The shunt regulator monitors the DC Bus voltage. If this voltage rises above a present threshold (Regen Turn On Voltage), the Geo Drive will turn on a power device intended to place the externally mounted regen resistor across the bus to dump the excessive energy. The power device keeps the regen resistor connected across the bus until the bus voltage is sensed to be below the Regen Turn Off voltage at which time the power device removes the resistor connection.

Minimum Resistance Value

The regen resistor selection requires that the resistance value of the selected resistor will not allow more current to flow through the Geo Drive's power device than specified.

Maximum Resistance Value

The maximum resistor value that will be acceptable in an application is one that will not let the bus voltage reach the drive's stated over voltage specification during the deceleration ramp time. The following equations defining energy transfer can be used to determine the maximum resistance value.

Energy Transfer Equations

Regen, or shunt, regulation analysis requires study of the energy transferred during the deceleration profile. The basic philosophy can be described as follows:

- The motor and load have stored kinetic energy while in motion.
- The drive removes this energy during deceleration by transferring to the DC bus.
- There are losses during this transfer, both mechanical and electrical, which can be significant in some systems.
- The DC bus capacitors can store some energy.
- The remaining energy, if any, is transferred to the regen resistor.

Kinetic Energy

The first step is to ascertain the amount of kinetic energy in the moving system, both the motor rotor and the load it is driving. In metric (SI) units, the kinetic energy of a rotating mass is:

$$E_K = \frac{1}{2} J \omega^2$$

where:

E_K is the kinetic energy in joules, or watt-seconds (J, W-s)

J is the rotary moment of inertia in kilogram-meter² (kg-m²)

ω is the angular velocity of the inertia in radians per second (1/s)

If the values are not in these units, convert them. For example, if the speed is in revolutions per minute (rpm), first multiply this value by $2\pi/60$ to convert to radians per second.

When English mechanical units are used, there are additional conversion factors that must be included to get the energy result to come out in joules. For example, if the rotary moment of inertia J is expressed in lb-ft-sec², the following equation should be used:

$$E_K = 0.678 J \omega^2$$

If the rotary moment of inertia J is expressed in lb-in-sec², the following equation should be used:

$$E_K = 0.0565 J \omega^2$$

In standard metric (SI) units, the kinetic energy of a linearly moving mass is:

$$E_K = \frac{1}{2}mv^2$$

where:

E_K is the kinetic energy in joules (J)

m is the mass in kilograms (kg)

v is the linear velocity of the mass in meters/second (m/s)

Here also, to get energy in Joules from English mechanical units, additional conversion factors are required. To calculate the kinetic energy of a mass having a weight of W pounds, the following equation can be used:

$$E_K = 0.678 \frac{W}{g} v^2 = 0.0211Wv^2$$

where:

E_K is the kinetic energy in joules (J)

W is the weight of the moving mass in pounds (lb)

g is the acceleration of gravity (32.2 ft/sec²)

v is the linear velocity of the mass in feet per second (ft/sec)

Energy Lost in Transformation

Some energy will be lost in the transformation from mechanical kinetic energy to electrical energy. The losses will be both mechanical, due to friction, and electrical, due to resistance. In most cases, these losses comprise a small percentage of the transformed energy and can be ignored safely because this leads to a conservative design. However, if the losses are significant and the system should not be over-designed, calculate these losses.

In metric (SI) units, the mechanical energy lost due to Coulomb (dry) friction in a constant deceleration to stop of a rotary system can be expressed as:

$$E_{LM} = \frac{1}{2}T_f \omega t_d$$

where:

E_{LM} is the lost energy in joules (J)

T_f is the resistive torque due to Coulomb friction in newton-meters (N-m)

ω is the starting angular velocity of the inertia in radians per second (1/s)

t_d is the deceleration time in seconds (s)

If the frictional torque is expressed in the common English unit of pound-feet (lb-ft), the comparable expression is:

$$E_{LM} = 0.678T_f \omega t_d$$

In metric (SI) units, the mechanical energy lost due to Coulomb (dry) friction in a constant deceleration to stop of a linear system can be expressed as:

$$E_{LM} = \frac{1}{2}F_f v t_d$$

where:

E_{LM} is the lost energy in joules (J)

F_f is the resistive force due to Coulomb friction in newtons (N)

v is the starting linear velocity in meters/second (m/s)

t_d is the deceleration time in seconds (s)

If the frictional force is expressed in the English unit of pounds (lb) and the velocity in feet per second (ft/sec), the comparable expression is:

$$E_{LM} = 0.678F_f v t_d$$

The electrical resistive losses in a 3-phase motor in a constant deceleration to stop can be calculated as:

$$E_{LE} = \frac{\sqrt{3}}{2} i_{rms}^2 R_{pp} t_d$$

where:

E_{LE} is the lost energy in joules (J)

i_{rms} is the current required for the deceleration in amperes (A), equal to the required deceleration torque divided by the motor's (rms) torque constant K_T

R_{pp} is the phase-to-phase resistance of the motor, in ohms (Ω)

t_d is the deceleration time in seconds (s)

Capacitive Stored Energy in the Drive

The energy not lost during the transformation is initially stored as additional capacitive energy due to the increased DC bus voltage. The energy storage capability of the drive can be expressed as:

$$E_C = \frac{1}{2} C (V_{regen}^2 - V_{nom}^2)$$

where:

E_C is the additional energy storage capacity in joules (J)

C is the total bus capacitance in Farads

V_{regen} is the DC bus voltage at which the regeneration circuit would have to activate, in volts (V)

V_{nom} is the normal DC bus voltage, in volts (V)

Evaluating the Need for a Regen Resistor

Any starting kinetic energy that is not lost in the transformation and cannot be stored as bus capacitive energy must be dumped by the regeneration circuitry in to the regen (shunt) resistor. The following equation can be used to determine whether this will be required:

$$E_{excess} = E_K - E_{LM} - E_{LE} - E_C$$

If E_{excess} in this equation is greater than 0, a regen resistor will be required.

Regen Resistor Power Capacity

A given regen resistor will have both a peak (instantaneous) and a continuous (average) power dissipation limit. It is therefore necessary to compare the required peak and continuous regen power dissipation requirements against the limits for the resistor.

The peak power dissipation that will occur in the regen resistor in the application will be:

$$P_{peak} = \frac{V_{regen}^2}{R}$$

where:

P_{peak} is peak power dissipation in watts (W)

V_{regen} is the DC bus voltage at which the regeneration circuit activates, in volts (V)

R is the resistance value of the regen resistor, in ohms (Ω)

However, this power dissipation will not be occurring all of the time, and in most applications, only for a small percentage of the time. Usually, the regen will only be active during the final part of a lengthy deceleration, after the DC bus has charged up to the point where it exceeds the regen activation voltage.

The average power dissipation value can be calculated as:

$$P_{avg} = P_{peak} \frac{\%on-time}{100}$$

where:

P_{avg} is average power dissipation in watts (W)

$\%on-time$ is the percentage of time the regen circuit is active

Note:

The Turn-on voltage for the Shunt circuitry for all low power Geo drives is 392V(

for High Power is 780V). There is a Hysteresis of 20V, so if the regen turns on @ 392V(780V), it will not turn off until it drops to 372V(740V).

Bonding

The proper bonding of shielded cables is imperative for minimizing noise emissions and increasing immunity levels. The bonding effect is to reduce the impedance between the cable shield and the back panel.

Power input wiring does not require shielding (screening) if the power is fed to the enclosure via metal conduit. If metal conduit is not used in the system, shielded cable is required on the power input wires along with proper bonding techniques.

Filtering

CE Filtering

Apply proper bonding and grounding techniques, described earlier in this section, when incorporating EMC noise filtering components to meet this standard.

Noise currents often occur in two ways. The first is conducted emissions passed through ground loops. The quality of the system-grounding scheme inversely determines the noise amplitudes in the lines. These conducted emissions are of a common-mode nature from line-to-neutral (ground). The second is radiated high-frequency emissions that usually are capacitively coupled from line-to-line and are differential in nature.

When mounting the filters, make sure the enclosure has an unpainted metallic surface. This allows more surface area to be in contact with the filter housing, and provides a lower impedance path between the housing and the back plane. The back panel should have a high frequency ground strap connection to the enclosure frame and earth ground.

Input Power Filtering

Caution:

To avoid electric shock, do not touch filters for at least 10 seconds after removing the power supply.

The Geo Drive electronic system components require EMI filtering in the input power leads to meet the conducted emission requirements for the industrial environment. This filtering blocks conducted -type emissions from exiting onto the power lines and provides a barrier for power line EMI.

Adequately size the system. The type of filter must be based on the voltage and current rating of the system and whether the incoming line is single or three-phase. One input line filter may be used for multi-axis control applications. These filters should be mounted as close to the incoming power as possible so noise is not capacitively coupled into other signal leads and cables. Implement the EMI filter according to the following guidelines:

- Mount the filter as close as possible to incoming cabinet power.
- When mounting the filter to the panel, remove any paint or material covering. Use an unpainted metallic back panel, if possible.
- Filters are provided with a ground connection. All ground connections should be tied to ground.
- Filters can produce high leakage currents; they must be grounded before connecting the supply.
- Do not touch filters for a period of 10 seconds after removing the power supply.

Motor Line Filtering

Motor filtering may not be necessary for CE compliance of Geo Drives. However, this additional

filtering increases the reliability of the system. Poor non-metallic enclosure surfaces and lengthy, unbonded (or unshielded) motor cables that couple noise line-to-line (differential) are some of the factors that may lead to the necessity of motor lead filtering.

Motor lead noise is either common-mode or differential. The common-mode conducted currents occur between each motor lead and ground (line-to-neutral). Differential radiated currents exist from one motor lead to another (line-to-line). The filtering of the lines feeding the motor provides additional attenuation of noise currents that may enter surrounding cables and equipment I/O ports in close proximity.

Differential mode currents commonly occur with lengthy motor cables. As the cable length increases, so does its capacitance and ability to couple noise from line-to-line. While every final system is different and every application of the product causes a slightly different emission profile, it may become necessary to use differential mode chokes to provide additional noise attenuation to minimize the radiated emissions. The use of a ferrite core placed at the Geo Drive end on each motor lead attenuates differential mode noise and lowers frequency (30 to 60 MHz) broadband emissions to within specifications. Delta Tau recommends a Fair-Rite P/N 263665702 (or equivalent) ferrite core.

Common mode currents occur from noise spikes created by the PWM switching frequency of the Geo Drive. The use of a ferrite or iron-powder core toroid places common mode impedance in the line between the motor and the Geo Drive. The use of a common mode choke on the motor leads may increase signal integrity of encoder outputs and associated I/O signals.

I/O Filtering

I/O filtering may be desired, depending on system installation, application, and integration with other equipment. It may be necessary to place ferrite cores on I/O lines to avoid unwanted signals entering and disturbing the Geo.

CONNECTORS

Connector Pinouts

X1: Encoder Input 1

The main encoder input channels for the Geo Drive support a variety of encoder feedback types. 5V supply to power the encoder is provided, along with four digital Hall sensors (UVWT) for phasing.

Quadrature Encoder Input, or SSI Absolute Encoders. Optional: Sinusoidal Encoder Input with x4096 Interpolation, Resolver Feedback, Endat and Hiperface Interfaces.

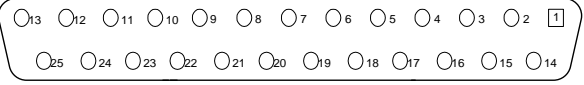
X1 Encoder Input 1 (DB-25 Female Connector)				
Pin #	Digital /SSI Encoder Symbol	Sinusoidal Encoder Symbol*	Resolver Symbol*	Use for Incremental Encoder/Sinusoidal Encoder/Resolver
1	ChA1+	Sin1+	N/A	Axis 1 Encoder A+/Encoder Sine+/Not used
2	ChB1+	Cos1+	N/A	Axis 1 Encoder B+/Encoder Cosine+/Not used
3	Index1+	Index1+	N/A	Axis 1 Encoder Index+/Encoder Index+/Not used
4	N/A	N/A	ResSin1+	Axis 1 Not used/Not used/Resolver Sine+
5	N/A	N/A	ResCos1+	Axis 1 Not used/Not used/Resolver Cosine+
6	CLK+	AltSin1+/CLK+	N/A	Axis 1 SSI Clock+/Power On Position Sine+, for Endat output CLK+/Not used
7	DAT+	AltCos1+/DAT+	N/A	Axis 1 SSI Data-/Power On Position Cosine+, for Endat input DATA+/Not used
8	ChU1+	ChU1+	ChU1+	Axis 1 U Commutation+
9	ChW1+	ChW1+	ChW1+	Axis 1 W Commutation+
10	BVREF1			Axis 1 Buffered 2.5 Volt Reference
11	N/A	N/A	ResOut1	Axis 1 Not used/Not used/Resolver Excitation Output
12	Encoder Power1	Encoder Power1	N/A	Encoder PWR/Encoder PWR/Not used. 5VDC
13	GND			Common
14	ChA1-	Sin1-	N/A	Axis 1 Encoder A-/Encoder Sine-/Not used
15	ChB1-	Cos1-	N/A	Axis 1 Encoder B-/Encoder Cosine-/Not used
16	Index1-	Index1-	N/A	Axis 1 Encoder Index-/Encoder Index-/Not used
17	N/A	N/A	ResSin1-	Axis 1 Not used/Not used/Resolver Sine-
18	N/A	N/A	ResCos1-	Axis 1 Not used/Not used/Resolver Cosine-
19	CLK-	AltSin1-/CLK-	N/A	Axis 1 SSI Clock-/Power On Position Sine-, for Endat output CLK-/Not used
20	DAT-	AltCos1-/DAT-	N/A	Axis 1 SSI Data-/Power On Position Cosine-, for Endat input DATA-/Not used
21	ChV1+	ChV1+	ChV1+	Axis 1 V Commutation+
22	ChT1+	ChT1+	ChT1+	Axis 1 T Commutation+ (supplemental Hall sensor)***
23	1_In_Therm_Mot			Motor 1 Thermal Input Switch
24	+5V			Axis 1, +5V Supply
25	GND			Common

* The Analog Feedback Option 1 or 4 is required for these functions.
 ** The Serial Encoder Feedback Option 2 or 5 is required for these functions
 *** Most Hall sensors do not use this line, so let it float if not used

X2: Encoder Input 2

The main encoder input channels for the Geo Drive support a variety of encoder feedback types. 5V supply to power the encoder is provided, along with four digital Hall sensors (UVWT) for phasing.

Quadrature Encoder Input, or SSI Absolute Encoders. Optional: Sinusoidal Encoder Input with x4096 Interpolation, Resolver Feedback, Endat and Hiperface Interfaces.

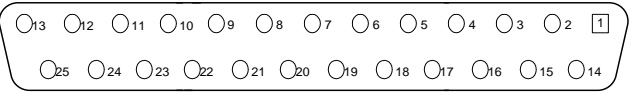
X2 Encoder Input 2 (DB-25 Female Connector)				
Pin #	Digital / SSI Encoder Symbol	Sinusoidal Encoder Symbol*	Resolver Symbol*	Use for Incremental Encoder/Sinusoidal Encoder/Resolver
1	ChA2+	Sin2+	N/A	Axis 2 Encoder A+/Encoder Sine+/Not used
2	ChB2+	Cos2+	N/A	Axis 2 Encoder B+/Encoder Cosine+/Not used
3	Index2+	Index2+	N/A	Axis 2 Encoder Index+/Encoder Index+/Not used
4	N/A	N/A	ResSin2+	Axis 2 Not used/Not used/Resolver Sine+
5	N/A	N/A	ResCos2+	Axis 2 Not used/Not used/Resolver Cosine+
6	CLK+	AltSin2+/CLK+	N/A	Axis 2 SSI Clock+/Power On Position Sine+, for Endat output CLK+/Not used
7	DAT+	AltCos2+/DAT+	N/A	Axis2 SSI Data+/Power On Position Cosine+, for Endat input DATA +/Not used
8	ChU2+	ChU2+	ChU2+	Axis 2 U Commutation+
9	ChW2+	ChW2+	ChW2+	Axis 2 W Commutation+
10	BVREF2			Axis 2 Buffered 2.5 Volt Reference
11	N/A	N/A	ResOut2	Axis 2 Not used/Not used/Resolver Excitation Output
12	Encoder Power2	Encoder Power2	N/A	Relay-Controlled Power/Relay-Controlled Power/Not used Default is Power ON, 5V
13	GND			Common
14	ChA2-	Sin2-	N/A	Axis 2 Encoder A-/Encoder Sine-/Not used
15	ChB2-	Cos2-	N/A	Axis 2 Encoder B-/Encoder Cosine-/Not used
16	Index2-	Index2-	N/A	Axis 2 Encoder Index-/Encoder Index-/Not used
17	N/A	N/A	ResSin2-	Axis 2 Not used/Not used/Resolver Sine-
18	N/A	N/A	ResCos2-	Axis 2 Not used/Not used/Resolver Cosine-
19	CLK-	AltSin2-/CLK-	N/A	Axis 2 SSI Clock-/Power On Position Sine-, for Endat output CLK-/Not used
20	DAT-	AltCos2-/DAT-	N/A	Axis 2 SSI Data -/Power On Position Cosine-, for Endat input DATA-/Not used
21	ChV2+	ChV2+	ChV2+	Axis 2 V Commutation+
22	ChT2+	ChT2+	ChT2+	Axis 2 T Commutation+ + (supplemental Hall sensor)***
23	2_In_Therm_Mot			Motor 2 Thermal Input Switch
24	+5V			Axis 2, +5V Supply
25	GND			Common

* The Analog Feedback Option 1 or 4 is required for these functions.
 ** The Serial Encoder Feedback Option 2 or 5 is required for these functions
 *** Most Hall sensors do not use this line, so let it float if not used

X3: General Purpose I/O

Discrete I/O is available on the Geo PMAC Drive. All I/O is electrically isolated from the drive. Inputs can be configured for sink or source applications (all eight inputs sinking or all eight inputs sourcing). All I/O is 24V nominal operation, 0.5A maximum current. Outputs are robust against ESD and overload.

X3 General Purpose I/O (Two 12-pin Terminal Blocks Male)			
Pin #	Symbol	Function	Notes
1	GP Input 1/ HOME3	Input	M1->X:\$C010,16
2	GP Input 2/ PLIM3	Input	M2->X:\$C010,17
3	GP Input 3/ MLIM3	Input	M3->X:\$C010,18
4	GP Input 4/ User3	Input	M4->X:\$C010,19
5	GP Input 5/ HOME4	Input	M5->X:\$C018,16
6	GP Input 6/ PLIM4	Input	M6->X:\$C018,17
7	GP Input 7/ MLIM4	Input	M7->X:\$C018,18
8	GP Input 8/ USER4	Input	M8->X:\$C018,19
9	IN COM 1-4	Input	Input 1-4 Common
10	IN COM 5-8	Input	Input 5-8 Common
11	COL COM	Input	Common Collector
12	COM EMT	Input	Common Emitter
13	GP Output 1+	Output	M9->Y:\$FFC4,0 *
14	GP Output 1-	Output	M9->Y:\$FFC4,0 **
15	GP Output 2+	Output	M10->Y:\$FFC4,1 *
16	GP Output 2-	Output	M10->Y:\$FFC4,1 **
17	GP Output 3+	Output	M11->Y:\$FFC4,2 *
18	GP Output 3-	Output	M11->Y:\$FFC4,2 **
19	GP Output 4+	Output	M12->Y:\$FFC4,3 *
20	GP Output 4-	Output	M12->Y:\$FFC4,3 **
21	GP Output 5+ /EQU3	Output	M311->Y:\$FFC0,4 *. ¹
22	GP Output 5- /EQU3	Output	M311->Y:\$FFC0,4 **. ¹
23	GP Output 6+ /EQU4	Output	M411->Y:\$FFC0,5 *. ²
24	GP Output 6- /EQU4	Output	M411->Y:\$FFC0,5 **. ²

Note

See notes on the following page regarding the I/O table above.

*For sinking outputs, connect the COM EMIT (pin12) line to the Common GND (Analog Ground) and the outputs to the individual plus output lines, e.g. GP OUTPUT 1+

**For sourcing outputs, connect the COM COL (pin11) line to 12-24V and the outputs to the individual minus output lines, e.g., GP OUTPUT 1-

Topologies cannot be mixed, i.e., all sinking or all sourcing outputs. If the common emitter is used, the common collector should be unconnected. Conversely, if the common collector is used, the common emitter should be unconnected.

Inputs can be used as Flags for channels 3 and 4.

^{1,2} For outputs 5 and 6, use EQU 3 and EQU4 line respectively.

M13->X:\$C015,11,1 ; EQU_3 compare flag latch control

M14->X:\$C015,12,1 ; EQU_3 output write enable

M15->X:\$C01D,11,1 ; EQU_4 compare flag latch control

M16->X:\$C01D,12,1 ; EQU_4 output write enable

Part Type: FKMC 0,5/12-ST-2,5 p/n: 18 81 42 0

Since M13 (output 5) and M14 (output 6) are using the same address as EQU3 and EQU4, change them as if you were latching EQU outputs. To do this, set M311=1 after each change to M13 (output5) and M411=1 after each change to M14 (output6)

Output 5 ON: m13=1 m311=1

Output 5 OFF: m13=0 m311=1

Output 6 ON: m14=1 m411=1

Output 6 OFF: m14=0 m411=1

Sample Wiring for the I/O, X3

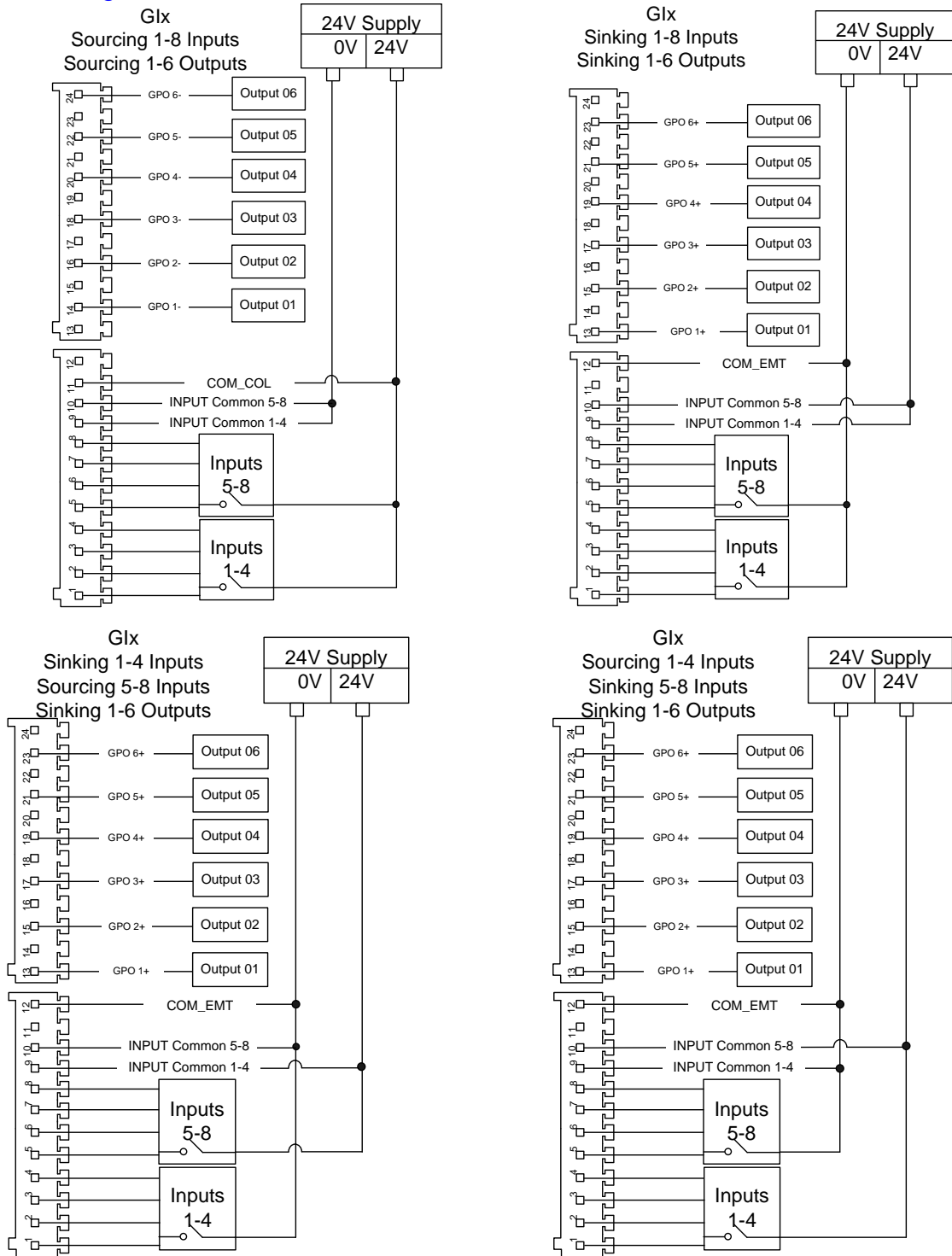

X4: Safety Relay (Optional)

Pin #	Symbol	Function
1	RELAY WA	Safety Input 24V
2	RELAY WB	Safety Input Return
3	RELAY COM	Common
4	RELAY N/O	Relay Normally Open

Pin #	Symbol	Function
1	RELAY WA	Safety Input 24V
2	RELAY WB	Safety Input Return
3	RELAY COM	Common
4	RELAY N/O	Relay Normally Open
Part Type: MC 1, 5/4-ST-3, 81, PITCH 3.81MM PN: 1850686		

If the Safety Relay option is installed, there is a dedicated Safety Input @24VDC (user supplied). When the Safety Input is asserted, then the hardware will cut the 20V power to the gate drive which will prevent all output from the power stage (the Gate Enable LED will turn off). If the user doesn't need to use the Safety Input and the drive has it installed, the user has to bypass it by wiring a 24VDC input to WA (pin 1) and the return (24VDC) to WB (pin 2).

Note:

There are no software configurable parameters to enable/disable or otherwise manipulate the Safety Input functionality.

X5: USB 2.0 Connector

This connector is used in conjunction with USB A-B cable, which can be purchased from any local computer store and is provided when Option 1A is ordered. The A connector is connected to a PC or Hub device; the B connector plugs into the J9-USB port.

Pin #	Symbol	Function
1	VCC	N.C.
2	D-	DATA-
3	D+	DATA+
4	GND	GND
5	SHELL	SHIELD
6	SHELL	SHIELD

X6: RJ45, Ethernet Connector

This connector is used for Ethernet communications from the Geo PMAC Drive to a PC.

Note:

Delta Tau Systems strongly recommends the use of RJ45 CAT5e or better shielded

cable.

Newer network cards have the Auto-MDIX feature that eliminates the need for crossover cabling by performing an internal crossover when a straight cable is detected during the auto-negotiation process.

For older network cards, one end of the link must perform media dependent interface (MDI) crossover (MDIX), so that the transmitter on one end of the data link is connected to the receiver on the other end of the data link (a crossover/patch cable is typically used). If an RJ45 hub is used, then a regular straight cable must be implemented.

Maximum length for Ethernet cable should not exceed 100m (330ft).

X7: Analog I/O (Optional, Option 3/4/5)

Two analog inputs with 16 Bit A/D converter and one filtered PWM 12-bit analog output.

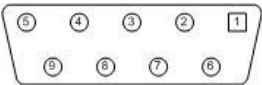
X7 Analog I/O (DB-9 Female Connector)				
Pin #	Symbol	Function	Description	Notes
1	AGND	Common		
2	DAC1-	Output	Filtered PWM 12-bit output +/-10V	
3	AGND	Common		
4	ADC2+	Input	Input level +/-10V	
5	ADC1+	Input	Input level +/-10V	
6	DAC1+	Output	Filtered PWM 12-bit output +/-10V	
7	5V	Output		
8	ADC2-	Input	Input level +/-10V	
9	ADC1-	Input	Input level +/-10V	

Using the Analog Inputs A/D (X7)

The Geo PMAC Drive can be ordered with two analog-to-digital converters (Option 3/4/5). These A/D converters are 16-bit devices that are ready to be used without any software setup. Delta Tau uses the Burr Brown ADS8343 for this circuit.

The analog signals for analog input #1 are wired in to pins 5 (ADC1+) and 9 (ADC1-), and for analog input #2 into pins 4 (ADC2+) and 8 (ADC2-).

When selected for bipolar mode, differential inputs allow the user to apply input voltages to ± 10 volts (20V p-p). When selected for unipolar mode, the user can apply input voltages from 0V to +10V (the negative input ADCn- must be grounded).

To read the A/D data from the Geo PMAC device, create the M-variable definitions.

;The data received is an unsigned 16-bit number scaled from 0V to +10V (0cts to 32767cts).

```
M1000->Y:$FF58,8,16,u ;ADC1
M1001->Y:$FF78,8,16,u ;ADC2
```

;The data received is a signed 16-bit number scaled from -10V to +10V (-32767cts to 32767cts).

```
M1000->Y:$FF58,8,16,S ;ADC1
M1001->Y:$FF78,8,16,S ;ADC2
```

Using the Analog Output (X7)

When the Geo PMAC drive is ordered with either Option 3, 4, or 5, one differential 12-bit filtered PWM analog output (analog output intended for use with loads > 5K impedance) is installed to the unit.

- Channel #3, Output M302->Y:\$C012,8,16,s

- I369=6527 ; DAC limit 10Vdc

For example, if M302=653, the output should be approximately 1Vdc.

X8: S. Encoder 1

The Secondary Encoder channel allows an external encoder to be fed back on the controller. A 5V supply is available for encoder power at pin 4. The three differential signal channels are brought into remaining pins as indicated. The encoder loop feedback address is \$C010

For example, to enter it in the ECT, write to the last empty entry (for this example entry 3):

WY:\$722,\$C010

Ix03 and Ix04 =\$722

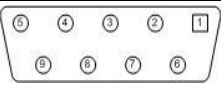
X8 S. Enc. 1 (DB-9 Female Connector)			
Pin #	Symbol	Function	Notes
1	Cha1+	Input	Secondary Encoder 1 A+
2	Chb1+	Input	Secondary Encoder 1 B+
3	Index1+	Input	Secondary Encoder 1 Index + /C+
4	5V	Out	Encoder Power
5	GND	Out	Common
6	Cha1-	Input	Secondary Encoder 1 A-
7	Chb1-	Input	Secondary Encoder 1 B-
8	Index1-	Input	Secondary Encoder 1 Index - /C-
9	N.C.		Not Connected

X9: S. Encoder 2

The Secondary Encoder channel allows an external encoder to be fed back on the controller. A 5V supply is available for encoder power at pin 4. The three differential signal channels are brought into remaining pins as indicated. The encoder loop feedback address is \$C018.

For example, to enter it in the ECT, write to the last empty entry (for this example entry 4):

WY:\$723, \$C018

Ix03 and Ix04 =\$723

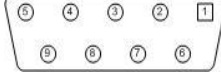
X9 S. Enc. 2 (DB-9 Female Connector)			
Pin #	Symbol	Function	Notes
1	Cha2+	Input	Secondary Encoder 2 A+
2	Chb2+	Input	Secondary Encoder 2 B+
3	Index2+	Input	Secondary Encoder 2 Index + /C+
4	5V	Out	Encoder Power
5	GND	Out	Common
6	Cha2-	Input	Secondary Encoder 2 A-
7	Chb2-	Input	Secondary Encoder 2 B-
8	Index2-	Input	Secondary Encoder 2 Index - /C-
9	N.C.		Not Connected

X10: Discrete I/O

The Geo PMAC limit and flag circuits also give the flexibility to wire in standard 12V to 24V limits and flags or wire in 5V level limits and flags on a channel basis. The default is set for the standard 12V to 24V inputs but if the resistor pack is added to the circuit, the card can read 5V inputs.

X10 Discrete I/O (Two 7-pin Terminal Blocks Male)				
Pin #	Symbol	Function	Description	Notes
1	HOME1	Input	Home Flag axis 1	M120->X:\$C000,16,1
2	PLIM1	Input	Positive Limit axis 1	M121->X:\$C000,17,1
3	MLIM1	Input	Negative Limit axis 1	M122->X:\$C000,18,1
4	USER1	Input	General User Flag 1	M115->X:\$C000,19,1
5	FL_RT1	Input	Return For All ch#1 Flags	+V (12 to 24V) or 0V
6	EQU1-	Output	Compare Output	M111->X:\$C005
7	GND	Common		
8	HOME2	Input	Home Flag axis 2	M220->X:\$C008,16,1
9	PLIM2	Input	Positive Limit axis 2	M221->X:\$C008,17,1
10	MLIM2	Input	Negative Limit axis2	M222->X:\$C008,18,1
11	USER2	Input	General User Flag 2	M215->X:\$C008,19,1
12	FL_RT2	Input	Return For All ch#2 Flags	+V (12 to 24V) or 0V
13	EQU2-	Output	Compare Output	M211->X:\$C00D
14	GND	Common		
<p>The Geo PMAC Drive limit and flag circuits also give the flexibility to wire in standard 12V to 24V limits and flags or wire in 5V level limits and flags on a channel basis.</p> <p>The default is set for the standard 12V to 24V inputs but if the resistor pack is added to the circuit, the card can read 5V inputs.</p> <p>If RP7 (limits 1) and RP8 (limits 2) are installed in the unit, the voltage level of the flags can be lowered to 5V.</p> <ul style="list-style-type: none"> • RP7 and RP8 for 5V flags: 1Kohm Sip, 8-pin, four independent Resistors • RP7 and RP8 for 12-24Vflags: Empty bank <p>Part Type: FKMC 0,5/7-ST-2,5 p/n: 18 81 37 0</p>				

Position Compare Port Driver IC

As with the other PMAC controllers, the Geo drive has the high-speed position compare outputs allowing the firing of an output based on position. This circuit will fire within 100 nsec of reaching the desired position. The position compare output port on the Geo PMAC drive has driver IC at component U27A and U27B. This IC gives a fast CMOS driver.

The following table lists the properties of each driver IC:

Part	# of Pins	Max Voltage and Current	Output Type	Max Frequency
DS75452N	8	5V, 10 mA	Totem-Pole (CMOS)	5 MHz

Limit and Flag Circuit Wiring

The Geo PMAC allows the use of sinking or sourcing position limits and flags to the controller. The opto-isolator IC used is a PS2705-4NEC-ND quad phototransistor output type. This IC allows the current to flow from return to flag (sinking) or from flag to return (sourcing).

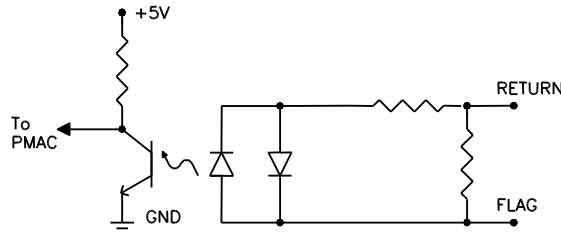

A sample of the positive limit circuit is shown below. The 4.7K resistor packs used will allow 12-24V flag inputs. If 0-5V flags are used, then a 1KΩ resistor pack (RP) can be placed in either RP7 (channel 1) or RP8 (channel 2). If these resistor packs are not added, all flags (\pm Limits, Home, User) will be referenced from 12-24V.

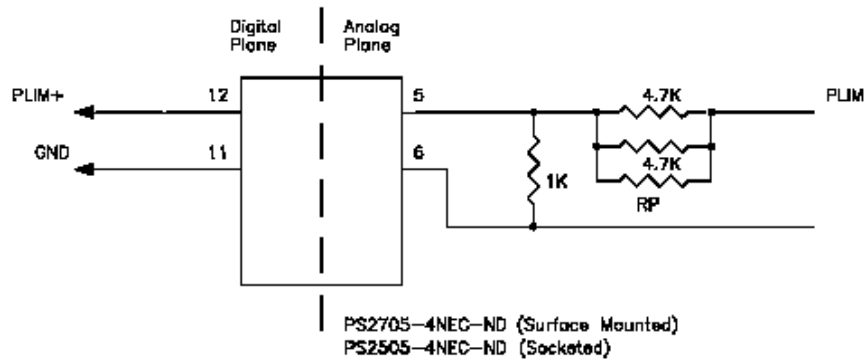

Connecting Limits/Flags to the Geo Drive

The following diagrams illustrate the sinking and sourcing connections to a Geo Drive. This example uses 12-24V flags.

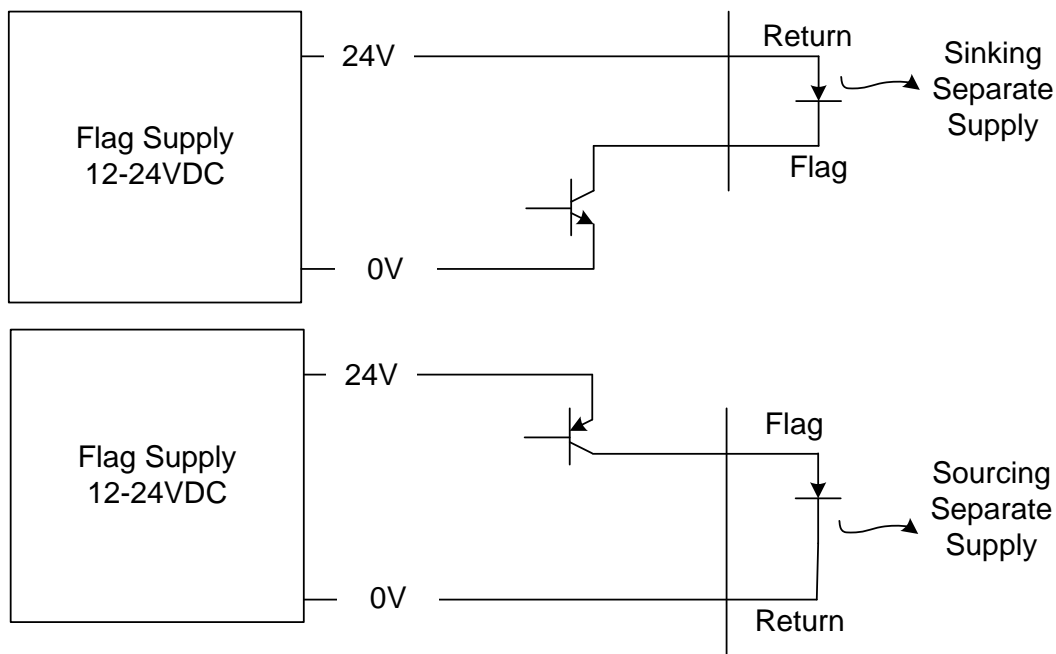

Sample Wiring for the Flags, X10

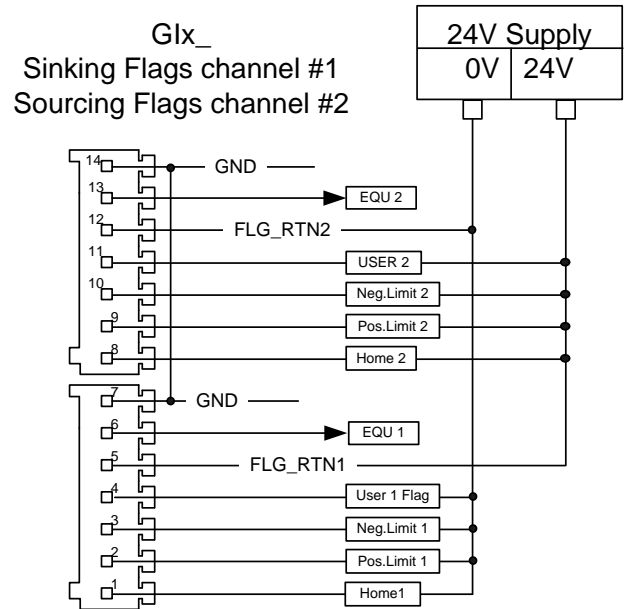
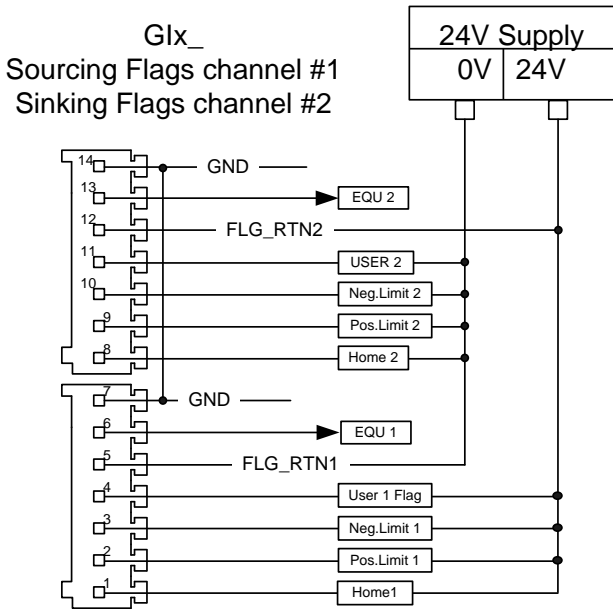
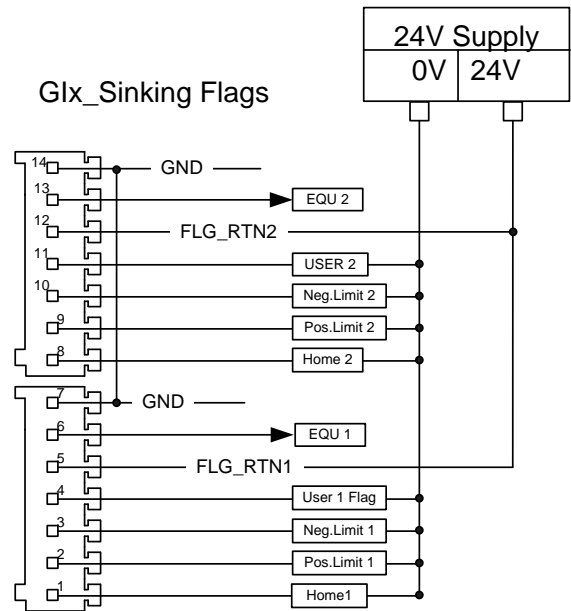
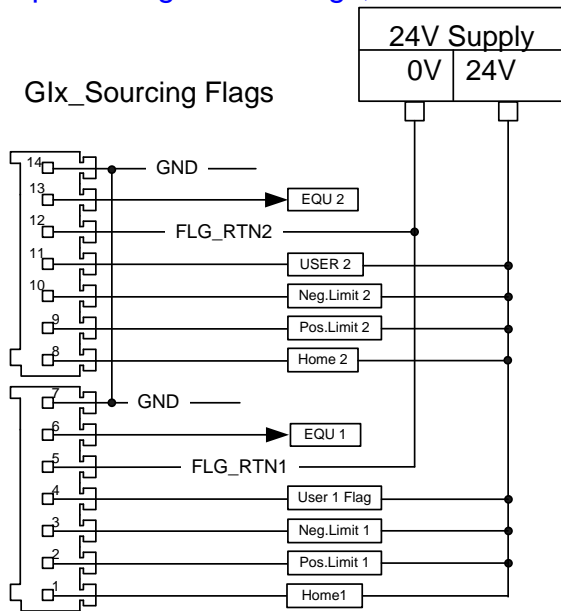

J1: AC Input Connector Pinout

Pin #	Symbol	Function	Description	Notes
1	L3	Input	Line Input Phase 3	
2	L2	Input	Line Input Phase 2	
3	L1	Input	Line Input Phase 1	(Not used for single Phase input)

On Gxx201xx and Gxx301xx, there is a fourth pin for GROUND connection.
 If DC bus is used, use L3 for DC+ and L2 for DC return.
 Connector is located at the bottom side of the unit

J2: Motor 1 Output Connector Pinout

Pin #	Symbol	Function	Description	Notes
1	U	Output	Axis 1 Phase1	
2	V	Output	Axis 1 Phase2	
3	W	Output	Axis 1 Phase3	

On Gxx201xx and Gxx301xx, there is a fourth pin for ground connection.
 Connector is located at the top side of the unit, for Ground connection use the screw with a lug

J3: Motor 2 Output Connector Pinout (Optional)

Pin #	Symbol	Function	Description	Notes
1	U	Output	Axis 2 Phase1	2- Axis drives only
2	V	Output	Axis 2 Phase2	2- Axis drives only
3	W	Output	Axis 2 Phase3	2- Axis drives only

Connector is located at the top side of the unit, for Ground connection use the screw with a lug

J4: 24VDC Input Logic Supply Connector

Pin #	Symbol	Function	Description	Notes
1	24VDC RET	Common	Control power return	
2	+24VDC	Input	Control power input	24V+/-10%, 2A

Connector is located at the bottom side of the unit

J5: External Shunt Connector Pinout

Pin #	Symbol	Function
1	Regen-	Output
2	Regen+	Output

Connector is located at the top side of the unit
 DT Connector part number #014-000F02-HSG and pins part number #014-043375-001
 Molex Crimper tool p/n#63811-0400

For the high Current Drives, Gxx201xx and Gxx301xx , this connector is a 3 pin Large Molex connector

Pin #	Symbol	Function
1	CAP-	Output
2	Regen-	Output
3	Regen+	Output

Connector is located at the top side of the unit.
 DT Connector part number #014-H00F03-049 and pins part number #014-042815-001.
 Molex Crimper tool p/n#63811-1500

SETTING UP THE ENCODERS

The Geo PMAC is a special version of the PMAC2 controller integrated with the amplifier in a single package. It adds a few features not available on other versions of the PMAC2 controller. For all other aspects of the software operation, the User's Manual and Software Reference Manual for the PMAC2 family of controllers can be used. This section covers the features unique to the Geo PMAC Drive.

Setting up Quadrature Encoders

Digital quadrature encoders are the most common position sensors used with Geo Drives. Interface circuitry for these encoders comes standard on board-level Turbo PMAC controllers, UMAC axis-interface boards, Geo drives, and QMAC control boxes.

Signal Format

Quadrature encoders provide two digital signals that are a function of the position of the encoder, each nominally with 50% duty cycle, and nominally one-quarter cycle apart. This format provides four distinct states per cycle of the signal, or per line of the encoder. The phase difference of the two signals permits the decoding electronics to discern the direction of travel, which would not be possible with a single signal.

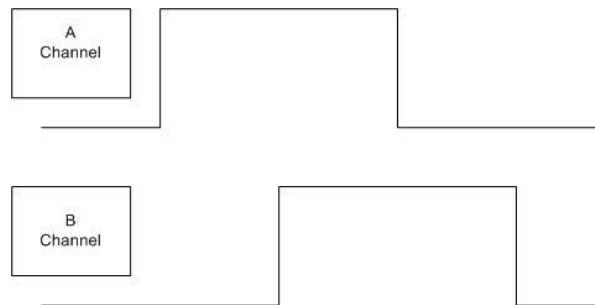

Typically, these signals are at 5V TTL/CMOS levels, whether single-ended or differential. The input circuits are powered by the main 5V supply for the controller, but they can accept up to +/-12V between the signals of each differential pair, and +/-12V between a signal and the GND voltage reference.

Differential encoder signals can enhance noise immunity by providing common-mode noise rejection. Modern design standards virtually mandate their use for industrial systems, especially in the presence of PWM power amplifiers, which generate a great deal of electromagnetic interference.

Hardware Setup

The Geo Drive accepts inputs from two digital encoders and provides encoder position data to the motion processor. X1 is encoder 1 connector and X2 is encoder 2. The differential format provides a means of using twisted pair wiring that allows for better noise immunity when wired into machinery.

Geo Drives encoder interface circuitry employs differential line receivers. The wiring diagram on the right shows an example of how to connect the Geo drive to a quadrature encoder.

Function	Pin #
ChA+	1
ChA-	14
ChB+	2
ChB-	15
ChC+	3
ChC-	16

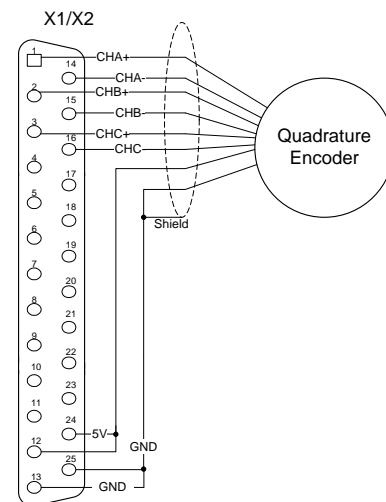

Encoder	Value	Description
I910 for ENC#1	3	Clockwise decode
I920 for ENC#2	7	Counter clockwise decode

Setting up SSI Encoders

The Geo Drive will take the data from the SSI encoder and process it as a binary parallel word. This data can then be processed in the PMAC encoder conversion table for position and velocity feedback. With proper setup, the information can also be used to commutate brushless and AC induction motors.

Caution:

Geo Drive was designed to work with either Gray Code or Binary Style SSI Encoders. The Geo Drive takes the gray/binary code information and converts it into a parallel binary word for absolute and ongoing position data

Hardware Setup

The differential format provides a means of using twisted pair wiring that allows for better noise immunity when wired into machinery.

The wiring diagram to the right shows an example of how to connect the Geo Drive to an SSI encoder.

Function	Pin#
CLK+	6
DATA+	7
CLK-	19
DATA-	20
ENCPWR/5V	12/24
GND	13/25

Note: We assume the SSI Encoder power requirements are for 5V, else use of an external power supply for the SSI encoder is required. Tie together the Geo Drive GND and the power supply for noise immunity

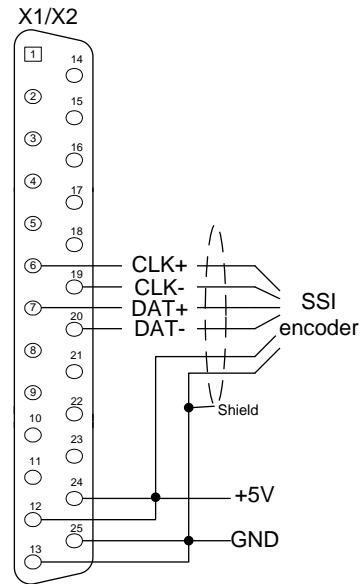

Software Setup

There are several parts of the software setup for the use of SSI encoders in the Geo PMAC. The first part is the software configuration of the hardware interface to establish the clock frequency (bit rate), number of bits, and expected data format. The second part is the processing of the received data in the encoder conversion table (ECT). The third part is defining the use of the processed data by the motor software.

Software Configuration of Hardware Interface

The SSI hardware interface on the Geo PMAC is software configurable. The configuration is done by assigning values to several I-variables.

SSI Clock Frequency

The SSI clock frequency, or bit rate, for both channels, is set by variable I1015. The following table shows the possible values of I1015 and the frequencies they select:

I1015	SSI Clock Freq.
0	153.6 kHz
1	307.2 kHz
2	614.4 kHz
3	1.2288 MHz

The highest frequency that does not exceed the capabilities of the sensor or the cabling should be selected.

Expected Data Format

The Geo PMAC can accept SSI data either in numeric binary format or in Gray code format, as selected by I1016 for Channel 1 and I1018 for Channel 2. The variable should be set to 2 for numeric binary, or to 3 for Gray code. If Gray code is selected, the Geo PMAC interface hardware will automatically convert the incoming data to numeric binary before latching it into a register for software access.

Word Length

The Geo PMAC interface hardware can be set up to clock in SSI words of 12, 16, 20, or 24 bits, as selected by I1017 for Channel 1 and I1019 for Channel 2. The following table shows that possible values of these variables and the word lengths they select:

I1017, I1019	Word Length
0	12 bits
1	16 bits
2	20 bits
3	24 bits

If your SSI word length is not one of these lengths, select the next highest length from this table. Then recognize that the data will be shifted up “too far”, so that the least significant bit (LSB) of the sensor will not end up in bit 0 of the latching register, and will not be treated as one “count” by the PMAC software. For example, if you have a 15-bit sensor, you should select the 16-bit word length by setting I1017 or I1019 to 1. Since the 15-bit data will be shifted one bit too far, the LSB from the sensor will appear in bit 1 of the resulting register, and be treated as 2 “counts” by PMAC.

Note:

I1015, I1016, I1017, I1018 and I1019 are only used with the Geo PMAC.

Encoder Conversion Table Setup

The encoder conversion table provides a pre-processing of the raw SSI feedback data so it can be used by the PMAC motor software properly. The encoder conversion table can be set up through an interactive menu in the Setup program (pending) or the Executive program, or by direct memory write commands.

The Geo PMAC will read the SSI encoder data as “parallel feedback”. The source data appears in register Y:\$FF54 for Channel 1 and Y:\$FF74 for Channel 2. Generally, the user should employ the “Y-word parallel, with filtering” conversion format (method \$3). This is a 3-line entry in the conversion table.

The first line of the entry specifies the method and the source address. It should be \$30FF54 to use Channel 1, or \$30FF74 to use Channel 2.

The second line of the entry specifies which bits of the source register are used. It should be set to \$000FFF for the 12-bit word length, to \$00FFFF for the 16-bit word length, to \$0FFFFFF for the 20-bit word length, or to \$FFFFFF for the 24-bit word length.

The third line of the entry specifies the maximum change in one servo cycle that will be accepted as real. It should be set to a value slightly greater (e.g. ~25%) than the maximum true velocity expected, expressed in counts per servo cycle.

The result of the conversion is in the X-register at the address of the last line of the entry. This address will be used by any task that needs to access the result. In the result register, the LSB from the encoder has been shifted left 5 bits – equivalent to a multiplication by 32, so the units of this result register are 1/32-count.

If the filtered parallel-read entry is the first entry in the ECT, its result will be in register X:\$0722. If a second filtered parallel-read entry immediately follows, its result will be in register X:\$0725.

Direct Memory Write Example

There is a 24-bit SSI encoder with a maximum speed of 200 LSBs per servo cycle connected to Channel 1, and a 16-bit SSI encoder with a maximum speed of 100 LSBs per servo cycle connected to Channel 2. The following direct memory-write commands could be used to set up the encoder conversion table for these sensors:

```
WY:$0720,$30FF54,$FFFFFF,256 ; 24-bit read from SSI Channel 1, 256 cts/cycle max  
WY:$0723,$30FF74,$00FFFF,128 ; 16-bit read from SSI Channel 2, 128 cts/cycle max
```

The result of the first conversion is in X:\$0722 (the third line of the first entry); the result of the second conversion is in X:\$0725 (the third line of the second entry).

Motor I-Variables

Ix03, Ix04: Position-Loop and Velocity-Loop Feedback Address

Ix03 and Ix04 specify the address of the X-register to be read for the feedback for Motor x’s position loop and velocity loop, respectively. Unless dual feedback is used for the motor, these two variables will specify the same address and so have the same value. These variables expect the specified register to have data in units of 1/32-count.

To use SSI feedback for these loops, these variables should specify the address of the result register in the encoder conversion table.

Ix10: Absolute Power-On Position and Format

Ix10 specifies the address of the register to be read for the absolute power-on position for Motor x, and

the format expected in that register. If your SSI sensor is absolute over the entire travel of the motor, you will want to use Ix10 to configure your absolute position read. If your SSI sensor is not absolute over the entire travel of the motor, leave Ix10 at the default value of 0 and establish your position reference with a homing search move.

Ix10 consists of 6 hexadecimal digits. The first two hex digits specify the format, and the last four hex digits specify the address of the source register. Ix10 expects the source data to be in units of counts, so it must use the hardware input registers at Y:\$FF54 and Y:\$FF74.

To read data from a Y-register, the first two hex digits simply specify the number of bits to be read as a hex number if the data is to be treated as an unsigned value, or as \$80 plus the number of bits to be read if the data is to be treated as a signed value.

The following table lists the values of Ix10 for the different possible SSI configurations:

Configuration	Ix10 to Use Channel 1	Ix10 to Use Channel 2
12-bit unsigned data	\$0CFF54	\$0CFF74
12-bit signed data	\$8CFF54	\$8CFF74
16-bit unsigned data	\$10FF54	\$10FF74
16-bit signed data	\$90FF54	\$90FF74
20-bit unsigned data	\$14FF54	\$14FF74
20-bit signed data	\$94FF54	\$94FF74
24-bit unsigned data	\$18FF54	\$18FF74
24-bit signed data	\$98FF54	\$98FF74

Ix83: Ongoing Phase Position Address

Ix83 specifies what register is to be read for the phase (commutation) position feedback every phase cycle. It expects data in units of counts, and it expects a full 24 bits of position data (it cannot handle the rollover of data at less than 24 bits).

If your SSI sensor is a full 24 bits and/or its data will never roll over (i.e. it is absolute over the full travel of the machine), you can read the SSI hardware input register here, setting Ix83 to \$8FF54 to read Channel 1 or to \$8FF74 to read Channel 2. The “8” specifies that the source data is in a Y-register.

However, if your SSI sensor provides less than 24 bits and it will roll over during operation (i.e. it is not absolute over the full travel of the machine), you will need to read instead the processed result of the conversion table for the sensor, which provides a full 24-bit rolled-over value. In our example case where the result of the Channel 1 conversion is in X:\$0722 and the result of the Channel 2 conversion is in X:\$0725, Ix83 would be set to \$0722 to use Channel 1 processed data, or to \$0725 to use Channel 2 processed data.

In this case, however, note that the units of the result registers are 1/32-count, whereas Ix83 expects data in units of counts. This means that you will need to specify your commutation cycle size with Ix70 and Ix71 as 32 times bigger than it would normally be.

Ix81: Power-On Phase Position Address and Format

Ix81 specifies what register is to be read for the phase (commutation) position feedback on power-on to establish the absolute rotor angle for a synchronous motor such as a permanent-magnet brushless servo motor, and what format that data is in. Virtually all SSI encoders are absolute over one motor revolution, so Ix81 will almost always be used in this case.

Ix81 consists of 6 hexadecimal digits. The first two hex digits specify the format, and the last four hex

digits specify the address of the source register. Ix81 should specify the same address as in Ix83, whether the hardware-input register for the encoder (Y:\$FF54 or Y:\$FF74), or the processed result in the conversion table (e.g. X:\$0722 or X:\$0725).

The first two hex digits specify the number of bits to be read (starting at bit 0 of the source), with an added \$40 if an X-register is read. The number of bits should express the number of bits of the SSI sensor in one revolution if the hardware-input register is used, or the number of bits plus 5 if the processed data in the ECT is used.

Remember that the difference between the zero point of the SSI encoder data (over one revolution) and the zero point of the commutation cycle (usually established once by a “stepper motor” phasing search) is held in variable Ix75 for the motor.

Ix70, Ix71: Commutation Cycle Size

The size of the commutation cycle size, in PMAC counts, is Ix71/Ix70. Normally Ix71 specifies the number of counts in a motor mechanical revolution, and Ix70 the number of pole pairs (commutation cycles) per mechanical revolution. For a linear motor, Ix70 is usually set to 1 and Ix71 set to the number of counts per pole pair of the motor.

If Ix83 specifies an SSI hardware input register (Y:\$FF54 or Y:\$FF74), a count here is equivalent to an LSB from the SSI sensor. However, if Ix83 specifies the processed result register in the conversion table (e.g. X:\$0722 or X:\$0725), a count here is equivalent to 1/32 of an LSB from the sensor, so Ix71 will have to be 32 times bigger than it otherwise would be.

Commutation Example 1

A 24-bit multi-turn SSI encoder with 12 bits (4096 LSBs) per mechanical revolution is used on a 6-pole brushless servo motor. It is wired into Channel 1 and is to be used for the phase commutation of Motor 1. Since the data is a full 24 bits, the hardware-input register can be used directly.

I183=\$8FF54 ; Read Y:\$FF54 for ongoing phase position
I181=\$0CFF54 ; Read low 12 bits of Y:\$FF54 for power-on phase position
I170=3 ; 3 pole pairs per mechanical revolution
I171=4096 ; 4096 counts per mechanical revolution

Commutation Example 2

A 12-bit single-turn SSI encoder is used on a 6-pole brushless motor that will turn many revolutions. It is wired into Channel 1 and is to be used for the phase commutation of Motor 1. It is processed in the first entry of the conversion table. Because the data is less than 24 bits and will roll over, we must use the processed result of the conversion table.

I183=\$0722 ; Read X:\$0722 for ongoing phase position
I181=\$510722 ; Read low 17 (12+5) bits of X:\$0722 for power-on phase position
I170=3 ; 3 pole pairs per mechanical revolution
I171=131072 ; 4096*32 PMAC counts per mechanical revolution

Setting up Sinusoidal Encoders

The Geo Drive with the Interpolator option accepts inputs from two sinusoidal or quasi-sinusoidal encoders and provides encoder position data to the motion processor. This interpolator creates 4,096 steps per sine-wave cycle.

The Interpolator can accept a voltage-source (1Vp-p) signal from the encoder. The maximum sine-cycle frequency input is approximately 8 MHz (1,400,000 SIN cycles/sec), which gives a maximum speed of about 5.734 billion steps per second.

When used with a 1000 line sinusoidal rotary encoder, there will be 4,096,000 discrete states per revolution (128,000 software counts). The maximum calculated electrical speed of this encoder would be 1,400 RPS or 84,000 RPM, which exceeds the maximum physical speed of most encoders.

Encoder Connections

Be sure to use shielded, twisted pair cabling for sinusoidal encoder wiring. Double insulated is the best. The sinusoidal signals are very small and must be kept as noise free as possible. Avoid cable routing near noisy motor or driver wiring. Refer to the appendix for tips on encoder wiring.

It is possible to reduce noise in the encoder lines of a motor-based system by the use of inductors that are placed between the motor and the amplifier. Improper grounding techniques may also contribute to noisy encoder signals.

Hardware Setup

The differential format provides a means of using twisted pair wiring that allows for better noise immunity when wired into machinery.

Sinusoidal encoders operate on the concept that there are two analog signal outputs 90 degrees out of phase. There are two common output types available with differential style sinusoidal encoders, these are current mode and voltage mode style encoder outputs.

The current mode encoder output uses a high impedance 11 μ A pk-pk output. The voltage mode output encoder uses a low impedance 1 V pk-pk output.

Geo Drives can be used with the voltage mode encoder type, and the lines have to be differential. The wiring diagram to the right shows an example of how to connect the Geo drive to a sinusoidal encoder.

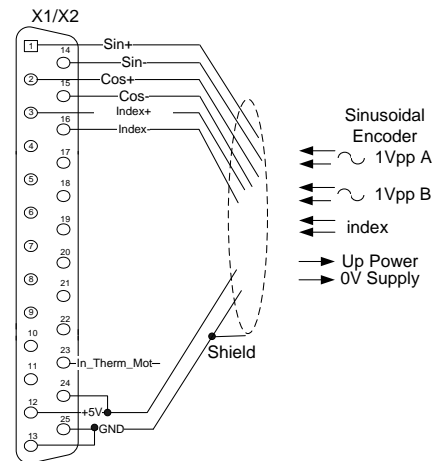

Function	Pin#
Sin+	1
Sin-	14
Cos+	2
Cos-	15
Index+	3
Index-	16

Note:

Voltage mode encoders are becoming the more popular choice for machine designs due to their lower impedance outputs. Lower impedance outputs represent better noise immunity, and therefore more reliable encoder interfaces. The Geo Drive uses only voltage mode encoders. 1Vp-p

Software Setup

Sinusoidal Encoder Decode	Value	Description
I910 for ENC#1 or I920 for ENC#2	3	x4 clockwise Decode
	7	x4 counterclockwise Decode
Note: This permits the user to set the direction sense by setting the decode variable to 3 or 7. However, if the variable is changed, the user must save the setting using the SAVE command and reset the card \$\$\$ before the fractional direction sense matches.		

To read the sinusoidal encoder feedback, set up the Encoder Conversion Table.

High-Resolution Encoder Interpolation Entries (\$F): The \$F entry converts the feedback from sinusoidal incremental encoders through the Geo PMAC's high-resolution interpolation circuitry, producing a result with 4096 states per line of the encoder.

Method/Address Word: The first line of the three-line entry contains \$F in the first hex digit and the base address of the encoder channel to be read in the low 16 bits (the third through sixth hex digits). In the Geo PMAC, the first encoder channel is at address \$C000 and the second encoder channel is at address \$C008, so the first setup line is set to \$F0C000 or \$F0C008.

A/D-Converter Address Word: The second line of the entry contains \$00 in the first two hex digits and the address of the first of the two A/D converters in the low 16 bits (the last four hex digits). The second A/D converter will be read at the next higher address. In the Geo PMAC, the first A/D converter for Channel 1 is at address \$FF00, and the first A/D converter for Channel 2 is at address \$FF20, so the second setup line is set to \$00FF00 or \$00FF20.

Sine/Cosine Bias Word: The third setup line in a high-resolution sinusoidal-encoder conversion entry contains bias terms for the sine and cosine ADC values. The high twelve bits (the first three hex digits) contain the bias term for the sine input; the low twelve bits (the last three hex digits) contain the bias term for the cosine input. Each 12-bit section should be treated as a signed 12-bit value (so if the most significant of the 12 bits is a 1, the bias value is negative).

Each 12-bit bias term should contain the value that the high 12 bits of the matching A/D converter report when they should ideally report zero. In action, the bias term will be subtracted from the high 12 bits of the corresponding ADC reading before subsequent calculations are done.

For example, if the bias word were set to \$004FFA, the sine bias would be +4 LSBs of a 12-bit ADC, and the cosine bias would be -6 LSBs (\$FFA = -6) of a 12-bit ADC. In use, 4 12-bit LSBs would be subtracted from the sine reading, and 6 12-bit LSBs would be added to the cosine reading each cycle before further processing.

Result Word: The output value of the high-resolution sinusoidal-encoder conversion in the Geo PMAC is placed in the 24-bit X-register of the third line of the conversion table entry. Bit 0 of the result contains the LSB of the conversion, representing 1/4096 of a line of the encoder. Since PMAC software considers the contents of Bit 5 to be a count for scaling purposes when used for servo feedback or master data, bit 0 will be considered 1/32 of a count. This means that PMAC software will scale the data as 128 software counts per line of the encoder.

Example:

Set the ECT:

WY:\$720,\$F0C000,\$FF00,0

; Sinusoidal interpolator #1, connected to X1

WY:\$723,\$F0C008,\$FF20,0

; Sinusoidal interpolator #2, connected to X2

Activate Motor X : Ix00

I100=1

;default is active

I200=1

;default is inactive, 0

Set the motor X position Loop Feedback Address: Ix03

I103=\$722

I203=\$725

Set the Motor X velocity Loop Feedback Address: Ix04

I104=\$722

I204=\$725

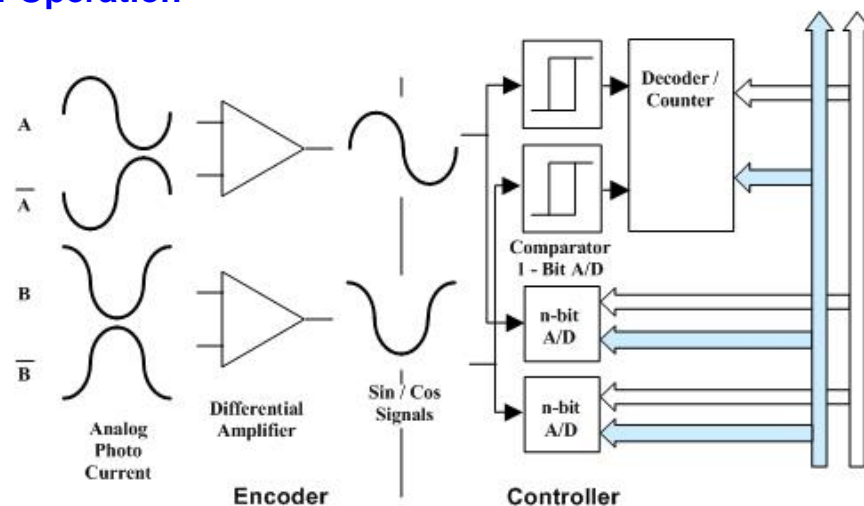
Principle of Operation

The sine and cosine signals from the encoder are processed in two ways in the Geo drive (see the diagram).

First, they are sent through comparators that square up the signals into digital quadrature and sent into the quadrature decoding and counting circuit of the Servo IC on the Geo drive. The decoding must be set up for quadrature times x4 decode ($I9n0 = 3$ or 7) to generate four counts per line in the hardware counter.

The units of the hardware counter, which are called hardware counts, are thus $\frac{1}{4}$ of a line. For most users, this fact is an intermediate value, an internal detail that does not concern them. However, this is important in two cases. First, if the sinusoidal encoder is used for PMAC-based brushless-motor commutation, the hardware counter, not the fully interpolated position value, will be used for the commutation position feedback. Therefore, the units of Ixx71 will be hardware counts.

Second, if the hardware position-compare circuits in the Servo IC are used, the units of the compare register are hardware counts. (The same is true of the hardware position-capture circuits, but often these scaling issues are handled automatically through the move-until-trigger constructs).

The second, parallel, processing of the sine and cosine signals is through analog-to-digital converters, which produce numbers proportional to the input voltages. These numbers are used to calculate mathematically an arctangent value that represents the location within a single line. This is calculated to $\frac{1}{4096}$ of a line, so there are 4096 unique states per line, or 1024 states per hardware count.

For historical reasons, PMAC expects the position it reads for its servo feedback software to have units of 1/32 of a count. That is, it considers the least significant bit (LSB) of whatever it reads for position feedback to have a magnitude of 1/32 of a count for the purposes of its software scaling calculations. We call the resulting software units software counts and any software parameter that uses counts from the servo feedback (e.g., jog speed in counts/msec, axis scale factor in counts/engineering-unit) is using these software counts. In most cases, such as digital quadrature feedback, these software counts are equivalent to hardware counts.

However, with the added resolution produced by the Geo Drive interpolator option, software counts and hardware counts are no longer the same. The LSB produced by the interpolator (through the encoder conversion table processing) is 1/1024 of a hardware count, but PMAC software considers it 1/32 of a software count. Therefore, with the Geo drive, a software count is 1/32 the size of a hardware count.

The following equations express the relationships between the different units when using the Geo Drive:

$$\begin{aligned}
 1 \text{ line} &= 4 \text{ hardware counts} = 128 \text{ software counts} = 4096 \text{ states (LSBs)} \\
 1/4\text{-line} &= 1 \text{ hardware count} = 32 \text{ software counts} = 1024 \text{ states (LSBs)} \\
 1/128\text{-line} &= 1/32\text{-hardware count} = 1 \text{ software count} = 32 \text{ states (LSBs)} \\
 1/4096\text{-line} &= 1/1024\text{-hardware count} = 1/32\text{-software count} = 1 \text{ state (LSB)}
 \end{aligned}$$

Note that these are all just naming conventions. Even the position data that is fractional in terms of software counts is real. The servo loop can see it and react to it, and the trajectory generator can command to it.

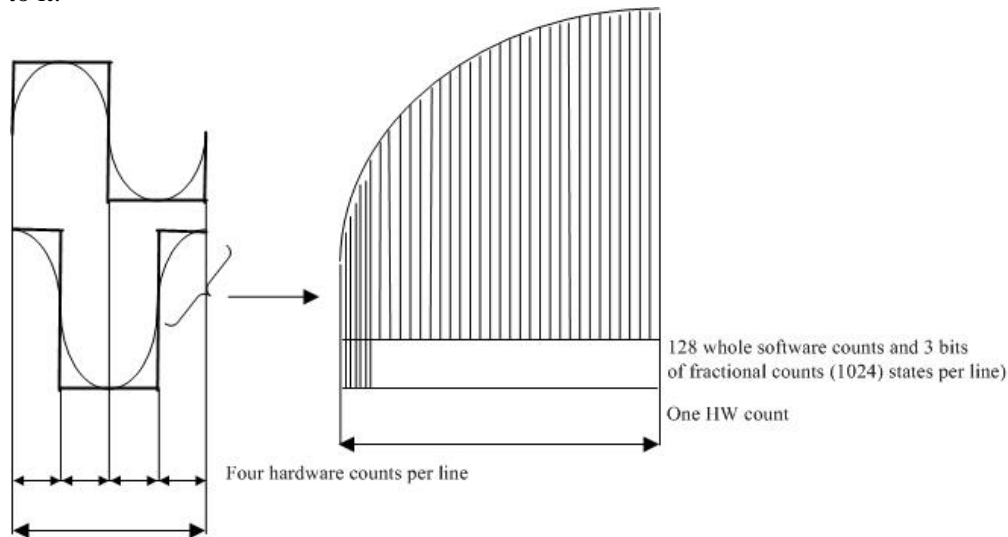

Example 1:

A 4-pole rotary brushless motor has a sinusoidal encoder with 2000 lines. It directly drives a screw with a 5-mm pitch. The encoder is used for both commutation and servo feedback.

The commutation uses the hardware counter. There are 8000 hardware counts per revolution, and two commutation cycles per revolution of the 4-pole motor. Therefore, Ixx70 will be set to 2, and Ixx71 will be set to 8000. Ixx83 will contain the address of the hardware counter’s phase capture register.

For the servo, the interpolated results of the conversion table are used. There are 128 software counts per line, or 256,000 software counts per revolution. With each revolution corresponding to 5 mm on the screw, there are 51,200 software counts per millimeter. The measurement resolution, at 4096 states per line, is 1/8,192,000 of a revolution, or 1/1,638,400 of a millimeter (~0.6 nanometers/state).

Example 2:

A linear brushless motor has a commutation cycle of 60.96 mm (2.4 inches). It has a linear scale with a 20-micron line pitch. The scale is used for both commutation and servo feedback.

The commutation uses the hardware counter. There are 200 hardware counts per millimeter (5 microns per count), so 12,192 hardware counts per commutation cycle. Ixx70 should be set to 1, and Ixx71 should be set to 12,192.

The servo uses the interpolated results of the conversion table. With 128 software counts per line, and 50 lines per millimeter, there are 6400 software counts per millimeter (or 162,560 software counts per inch). The measurement resolution, at 4096 states per line, is 204,800 states per mm (~5 nanometers/state).

Setting up EnDat Interface

The Geo Drive will read the absolute data from the EnDat (**Encoder Data**) interface only if the appropriate option is ordered.

Note:

For EnDat Interface firmware version 1.17C is required

Hardware Setup

The differential format provides a means of using twisted pair wiring that allows for better noise immunity when wired into machinery.

The wiring diagram to the right shows an example of how to connect the Geo Drive to an EnDat interface.

Function	Pin#
Sin+/ ChA+	1
Cos+/ChB+	2
Sin-/ChA-	14
Cos-/ChB-	15
CLK+	6
DATA+	7
CLK-	19
DATA-	20
ENCPWR/5V	12/24
GND	13/25

Note: We assume the EnDat Interface power requirements are for 5V, else use of an external power supply for the EnDat is required. Tie together the Geo Drive GND and the power supply GND for noise immunity.

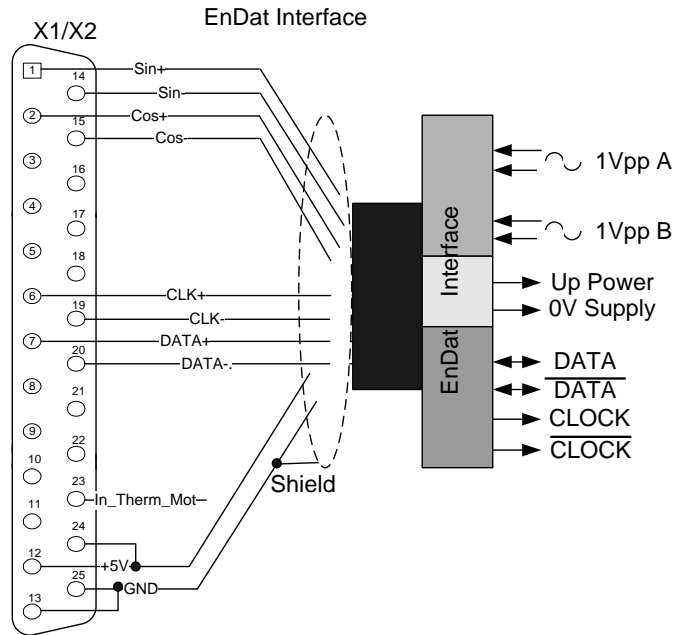

Software Setup

In the next two pages we discuss how to setup the Geo PMAC drive to read the absolute data and Power up on absolute position.

For Quadrature encoder data reading read the “Setting up Quadrature encoders” section of this manual. (1/T Interpolation)

For Sinusoidal encoder data reading read the “Setting up sinusoidal encoders” section of this manual. (x4096 Interpolation)

Ix10 Setup for Geo PMAC drive in use with EnDat

PMAC power on absolute position is acquired by Ix10. If an EnDat is used, Ix10 must be set properly for power on absolute encoder data reading.

Bit 23 of Ix10 specifies whether the position is interpreted as unsigned value (Bit 23=0 making the first Hex digit a 7) or as a signed value (Bit 23=1, making the first Hex digit an F). Set Ix10 equal to \$75wxyz for unsigned, or to \$F5wxyz for signed.

Bits 8 to 15 (wx) contain the data width from the EnDat. For example, if 23-bits were to be read, these two hex digits would be set to \$17. Another example for 28-bits were to be read the value would be: \$1C.

The fifth hex digit “y”, bits 4 to 7, specify the shift of the data read, permitting the user to match the resolution properly with that of the ongoing position. The data is first shifted left 10-bits, then shifted right by “y” bits, so “y” should be set (NetRightShift + 10). The object is to end up with data whose LSB is equal to one quadrature count (1/4-line) of the encoder. Most commonly the of 2 bits, so “y” should be a hex digit of “C” (12 decimal).

The sixth hex digit “z”, specifies the channel number used, whether the data is negated, and whether it should be matched to ongoing digital quadrature or analog sinusoidal feedback.

- Bit 3 is set to 0 to use the data without negation, or to 1 to negate the data before use. Negating the data reverses the direction sense; this control is used to match the direction sense of the ongoing feedback as set by I9n0.
- Bit 2 designates the use of a sinusoidal encoder or a quadrature encoder. It is set to 0 if the ongoing feedback is analog sinusoidal processed through the high resolution conversion (format \$F) in the conversion table, or to 1 if the ongoing feedback is digital quadrature.
- Bits 0 and 1 together express the channel number minus one as a value from 0 to 3 (so channel 1 to 4). For Geo PMAC Drives only channel 1 and 2 are supported and it is almost always used with interpolated sinusoidal ongoing feedback.

So as to enable sinusoidal EnDat for channel #1, “z” should be equal to 0 or 8 (regular or negated, respectively). And for the second channel “z” should be equal to 1 or 9 (regular or negated, respectively).

Ix81 Setup for Geo PMAC drive in use with EnDat

If Ix81 is set to \$75wxyz on a Geo PMAC drive, Motor x will expect its power-on phase position from the optional EnDat interface that can be ordered with the Geo PMAC.

“wxyz” are setup the same way as the Ix10 described above.

Example 1:

We have a 4 pole brushless motor (2 commutation cycles) with a 1024lines per revolution Quadrature EnDat device and “times 4” decode is used. So as to set it up for unsigned absolute position readings we need to set the ECT for channel #1: WY:\$720,\$C000, and Ix10, Ix03

I110=\$7517C4 ; 1/T, EnDat, unsigned

I103=\$720

For Power up on Phase we need to set Ix70, Ix71, Ix81 and Ix83. The encoder counts (1024lines/rev x 4 = 4096 cts/rev) are divisible with 2 (number of commutation cycles). Therefore I170=2 and I171=4096 could be used, or I170=1 and I171=2048

I170=1

I171=2048

I181=\$750BC4 ; 11 bits/rev, 1/T scale Power on Phase Format/Address

I183 = \$C001 ; Default setting

Example 2:

Same with Example 1 but we would like to read “signed” absolute data now.

I110=\$F517C4 ; 1/T EnDat signed

I103=\$720

For Power up on Phase the I-vars are the same with example 1.

Example 3:

We have a 4 pole brushless motor (2 commutation cycles) with a 1024lines per revolution Sinusoidal EnDat device and “times 4096” interpolation is used (5-bits of fraction x32). So as to set it up for unsigned absolute position readings we need to set the ECT for channel #1: WY:\$720,\$F0C000,\$FF00,0, and Ix10, Ix03

I110=\$751C70 ; Sinusoidal, EnDat, unsigned

I103=\$722

For Power up on Phase we need to set Ix70, Ix71, Ix81 and Ix83. The encoder counts (1024lines/rev x 128 whole counts interpolated = 131,072 cts/rev) are divisible with 2 (number of commutation cycles). Therefore I170=2 and I171=131,072 could be used, or I170=1 and I171=65,536

I170=1

I171=65,536

I181=\$750BC0 ; 11 bits/rev, 1/T scale Power on Phase Format/Address

I183 = \$C001 ; Default setting

Example 4:

Same with Example 3 but we would like to read “signed” absolute data now.

I110=\$F51C70 ; Sinusoidal, EnDat, signed

I103=\$722

For Power up on Phase the I-vars are the same with example 3.

Setting up Resolvers

The Geo PMAC Drive has up to two channels of resolver inputs. The inputs may be used as feedback or master reference signals for the PMAC servo loops. The basic configuration of the drive contains one 12-bit resolution (x4096) tracking resolver-to-digital (R-to-D) converters, with an optional second resolver when a dual axis driver is ordered. The Geo drive creates the AC excitation signal (ResOut) for up to two resolvers, accepts the modulated sine and cosine signals back from these resolvers, demodulates the signals and derives the position of the resolver from the resulting information, in an absolute sense if necessary.

Hardware Setup

The Geo Drive can interface to most industry standard resolvers. Typical resolvers requiring 5 to 10 kHz excitation frequencies with voltages ranging from 5 to 10V peak-to-peak are compatible with this drive.

Fundamentally, the Geo Drive connects three differential analog signal pairs to each resolver: a single excitation signal pair, and two analog feedback signal pairs. The wiring diagram below shows an example of how to connect the Geo drive to the Resolver.

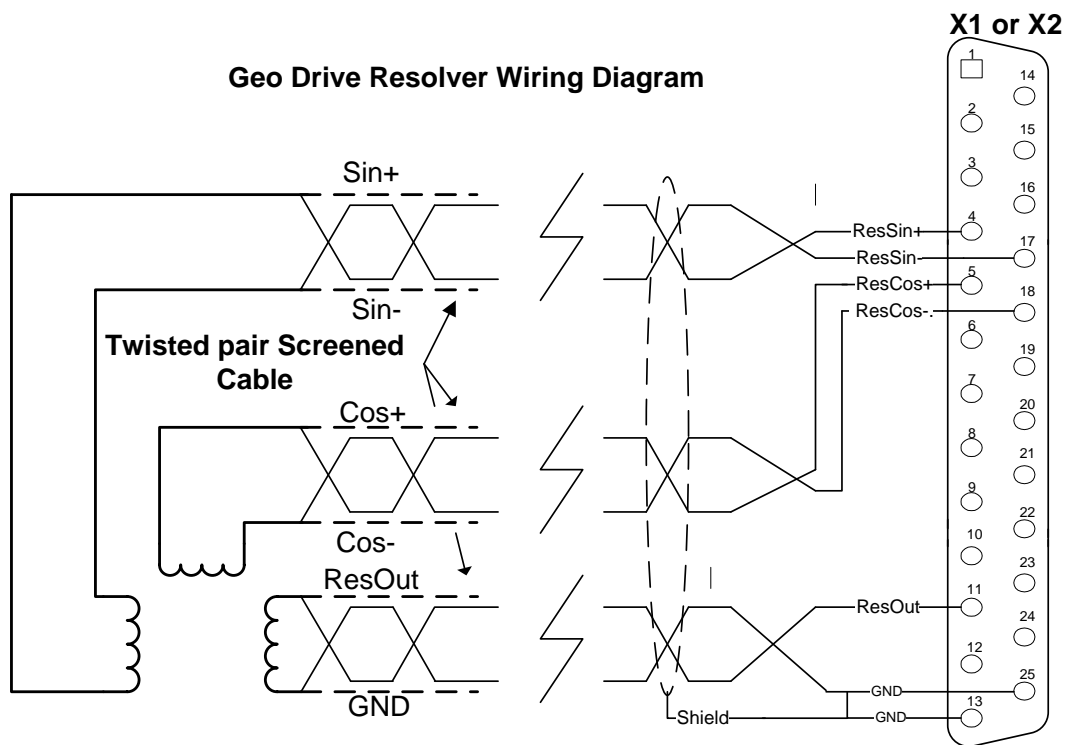

Notes:

Terminate shields on pins 13 and 25

Line	Pin #
ResSin+	4
ResSin-	17
ResCos+	5
ResCos-	18
ResOut	11
GND	13,25

Software Setup

Resolver Conversion Entries (\$E): The \$E entry converts the sine and cosine resolver feedback values processed through the Geo PMAC's A/D converter (ADC) registers to a 16-bit resolver angle value.

Method/Address Word: The first setup line of a resolver conversion entry contains \$E in the first hex digit and the address of the first ADC register to be read in the low 16 bits (the third through sixth hex digits). If bit 19 of the line is set to 0 (making the second hex digit \$0) the conversion creates a clockwise rotation sense. If bit 19 of the line is set to 1 (making the second hex digit \$8), the conversion creates a counter-clockwise rotation sense.

The two base ADC addresses presently supported by the Geo PMAC for resolver conversion are \$FF00 for Channel 1 and \$FF20 for Channel 2. Therefore, the possible first-setup-line values are:

First Setup Line	Conversion
\$E0FF00	Channel 1 CW
\$E8FF00	Channel 1 CCW
\$E0FF20	Channel 2 CW
\$E8FF20	Channel 2 CCW

Excitation Address Word: The second setup line in a resolver conversion entry contains the address of the excitation value register in the low 16 bits (the third through sixth hex digits), used to correlate the excitation and the feedback values. The excitation register is presently at a fixed address of \$FF5C in the Geo PMAC, so this line should be \$00FF5C.

Sine/Cosine Bias Word: The third setup line in a resolver conversion entry contains bias terms for the sine and cosine ADC values. The high twelve bits (the first three hex digits) contain the bias term for the sine input; the low twelve bits (the last three hex digits) contain the bias term for the cosine input. Each 12-bit section should be treated as a signed 12-bit value (so if the most significant of the 12 bits is a 1, the bias value is negative).

Each 12-bit bias term should contain the value that the high 12 bits of the matching A/D converter report when they should ideally report zero. In action, the bias term will be subtracted from the high 12 bits of the corresponding ADC reading before subsequent calculations are done.

For example, if the bias word were set to \$004FFA, the sine bias would be +4 LSBs of a 12-bit ADC, and the cosine bias would be -6 LSBs (\$FFA = -6) of a 12-bit ADC. In use, 4 12-bit LSBs would be subtracted from the sine reading, and 6 12-bit LSBs would be added to the cosine reading each cycle before further processing.

The resolver conversion can only be used if the Geo PMAC's Feedback Option 1 for analog position feedback is ordered.

Result Word: The output value of the resolver conversion is placed in the 24-bit X-register of the third line of the conversion table entry. The low five bits of the result word (which contain fractional values in some conversions) are always zero. The LSB of the 16-bit result is in bit 5, which PMAC software considers a count. The result data for one electrical cycle of the resolver is therefore in bits 5 – 20. Bits 21 – 23 contain cycle data from software extension of the result to multiple cycles.

Example:

Set the ECT:

```
WY:$720,$E0FF00,$FF5C,0      ;resolver#1CW
WY:$723,$E0FF20,$FF5C,0      ;resolver#2 CW
```

Activate motor x : Ix00

```
I100=1                        ;default is active
I200=1                        ;default is inactive, 0
```

Set the motor x position loop feedback address: Ix03

I103=\$722

I203=\$725

Set the motor x velocity loop feedback address: Ix04

I104=\$722

I204=\$725

Set the resolver special I-variables:

I1010=120

I1011=1

I1012=1

I1010 Resolver Excitation Phase Offset

Range: 0 – 255

Units: 1/256 cycle

Default: 0

I1010 specifies the phase (time) offset for the AC excitation created by the Geo PMAC for resolvers. The optimum setting of I1010 depends on the L/R time constant of the resolver circuit. I1010 should be set interactively so as to maximize the magnitudes of the feedback ADC values (Y:\$FF00 and Y:\$FF01 for Resolver 1; Y:\$FF20 and Y:\$FF21 for Resolver 2).

I1010 is only used if the Geo PMAC’s Feedback Option 1 for analog position feedback is ordered.

I1011 Resolver Excitation Gain

Range: 0 – 3

Units: Gain-1

Default: 0

I1011 specifies the gain of the AC excitation output created by the Geo PMAC for resolvers, with the gain equal to (I1011 + 1). With a gain of 1, the nominal AC output has peak voltages of +/-2.5V. The following table lists the possible values of I1011 and the nominal output magnitudes they produce:

I1011	Excitation Mag.
0	+/-2.5V
1	+/-5.0V
2	+/-7.5V
3	+/-10.0V

I1011 is only used if the Geo PMAC’s Feedback Option 1 for analog position feedback is ordered.

I1012 Resolver Excitation Frequency Divider

Range: 0 – 3

Units: none

Default: 0

I1012 specifies the frequency of the AC excitation output created by the Geo PMAC for resolvers as a function of the phase clock frequency set by I900 and I901. The following table lists the possible values of I1012 and the excitation frequencies they produce:

I1012	Excitation Freq.
0	PhaseFreq
1	PhaseFreq/2
2	PhaseFreq/4
3	PhaseFreq/6

I1012 is only used if the Geo PMAC’s Feedback Option 1/4 for analog position feedback is ordered.

Setting Up Digital Hall Sensors

Many motor manufactures now give the consumer the option of placing both Hall effect sensors and quadrature encoders on the end shaft of brushless motors. This will allow the controller to estimate the rotor magnetic field orientation and adjusts the command among the motor phases properly without rotating the motor at power-up. If this is not done properly, the motor or amplifier could be damaged.

Three-phase digital hall-effect position sensors (or their equivalent) are popular for commutation feedback. They can also be used with any PMAC as low-resolution position/velocity sensors. As commutation position sensors, typically, they are just used by PMAC for approximate power-up phase position; ongoing phase position is derived from the same high-resolution encoder that is used for servo feedback. (Many controllers and amplifiers use these hall sensors as their only commutation position feedback, starting and ongoing, but that is a lower-performance technique.)

Many optical encoders have hall tracks. These commutation tracks provide signal outputs equivalent to those of magnetic hall commutation sensors, but use optical means to create the signals.

Note:

These digital hall-effect position sensors should not be confused with analog hall-effect current sensors used in many amplifiers to provide current feedback data for the current loop.

Signal Format

Digital hall sensors provide three digital signals that are a function of the position of the motor, each nominally with 50% duty cycle, and nominally one-third cycle apart. (This format is often called 120° spacing. Geo PMAC has no automatic hardware or software features to work with 60° spacing.) This format provides six distinct states per cycle of the signal. Typically, one cycle of the signal set corresponds to one electrical cycle, or pole pair, of the motor. These sensors, then, can provide absolute (if low resolution) information about where the motor is in its commutation cycle, and eliminate the need to do a power-on phasing search operation.

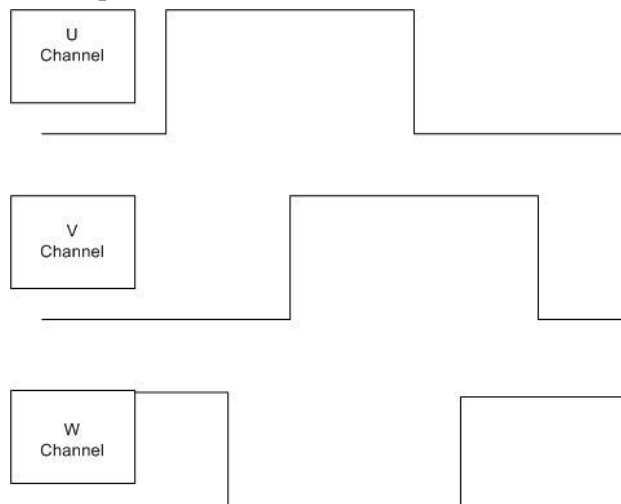

Hardware Setup

If used for power-up commutation position feedback only, typically the hall sensors are wired into the U, V, and W supplemental flags of X1 and X2 connectors of the Geo Drive. These are single-ended 5V digital inputs on all existing hardware implementations. They are not optically isolated inputs; if isolation is desired from the sensor, this must be done externally.

The wiring diagram on the right side of the page shows an example of how to connect the Geo drive to the Hall Sensors.

Function	Pin #
U	8
V	21
W	9
T	22
5V	12,24
GND	13,25

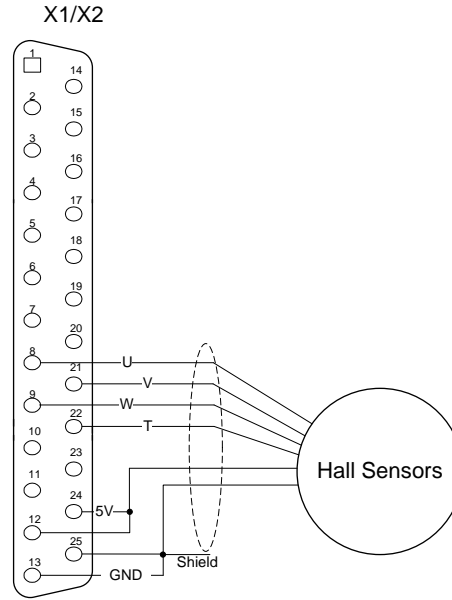

Note:

In the case of magnetic hall sensors, the feedback signals often come back to the controller in the same cable as the motor power leads. In this case, the possibility of a short to motor power must be considered; safety considerations and industrial design codes may make it impermissible to connect the signals directly to the Geo PMAC TTL inputs without isolation.

If used for servo position and velocity feedback, the three hall sensors are connected to the A, B, and C encoder inputs, so that the signal edges can be counted. As with quadrature encoders, these inputs can be single-ended or differential. They are not optically isolated inputs; if isolation is desired from the sensor, this must be done externally. There may be applications in which the signals are connected both to U, V, and W inputs (for power-on commutation position) and to A, B, and C inputs (for servo feedback).

Using Hall Effect Sensors for Phase Reference

There are usually four things to be considered about the alignment of the Hall Effect Sensors in order to properly set up Hall Effect phasing within the Geo Drive.

- Commutation Phase angle –based on Ix72
- Hall Effect Transition Points
- Hall Effect Zero position with respect to PMAC’s electrical zero
- Polarity of the Hall Effects – standard or reversed

Determining the Commutation Phase Angle

The commutation phase angle most likely has been set up already and it can be checked by querying the value of Ix72. For details on how this is determined, see the PMAC2 User’s Manual under Commutation Phase angle for either Sinusoidal Commutation or Direct PWM Commutation.

	Ix72=85	Ix72=171
Commutation Phase Angle	120 degrees	240 degrees

Finding the Hall Effect Transition Points

Usually, hall-effect sensors map out six zones of 60° elec each. In terms of PMAC2's commutation cycle, usually the boundaries will have one of two different combinations. If the Hall effect sensors are placed at 30°, 150°, and 270°, then the boundaries will be located at 180°, -120°, -60°, 0°, 60°, and 120°. Another common placement of Hall Effect Sensors has them located at 0°, 120°, and 240°. In this case, the boundaries will be located at 30°, 90°, 150°, -150°, -90°, and -30°. Typically, a motor manufacturer will align the sensors to within a few degrees of this, because these are the proper boundary points if all commutation is done from the commutation sensors. If mounting the hall-effect sensors manually, take care to align the boundaries at these points. The simplest way is to force the motor to the zero degree point with a current offset (as described below) and adjust the sensor while watching its outputs to get a boundary as close as possible to this point.

In order to determine where the Hall effect transition points are located, there must be a method of reading the status in software from the PMAC Executive Software or equivalent setup software. To do this, define M-variables to the Hall-Effects or equivalent inputs. Suggested definitions for Channel 1 are:

	Description
M124->X:\$C000,20	Channel 1 W flag
M125->X:\$C000,21	Channel 1 V flag
M126->X:\$C000,22	Channel 1 U flag
M127->X:\$C000,23	Channel 1 T flag
M128->X:\$C000,20,4	Channel 1 TUVW as a 4-bit value
M171->X:\$0040,0,24,S	Channel 1 Phase Position Register (counts *I170)

Suggested definitions for Channel 2 are:

	Description
M224->X:\$C008,20	Channel 2 W flag
M225->X:\$C008,21	Channel 2 V flag
M226->X:\$C008,22	Channel 2 U flag
M227->X:\$C008,23	Channel 2 T flag
M228->X:\$C008,20,4	Channel 2 TUVW as a 4-bit value
M271->X:\$007C,0,24,S	Channel 2 Phase Position Register (counts *I270)

Make these definitions and add these variables to the Watch window (delete other variables that no longer need to be monitored). With the motor killed, move the motor slowly by hand to verify that the inputs that should change do change.

To map the hall-effect sensors, use the current-loop six-step test, or a variant of it, to force the motor to known positions in the commutation cycle and observe the states of the hall-effect signals.

Calculating the Hall Effect Zero Point (HEZ)

The first step in finding the Hall Effect Zero point is to create a chart of the Hall Sensor Values at different points in the Electrical Cycle. Use the Current Loop 6-step method to do this. Perform the Current Loop 6-step method as described below and record the U (M126), V (M125), and W (M124) values at each step in the procedure.

Current Loop Six-Step Procedure

Commutation Phase Angle at 120° -> Ix72= 85

Hall Sensors at 30°, 150°, and 270°

```
P179=I179   P129=I129           ; store previous offsets before test
#1o0                ; Open loop command of zero magnitude
```

Six Step Method	U (Mx26)	V(Mx25)	W(Mx24)
I179=3000 I129=-1500 ; -30°elec.			
I179=1500 I129=1500 ; 30°elec.			
I179=-1500 I129=3000 ; 90°elec.			
I179=-3000 I129=1500 ; 150°elec.			
I179=-1500 I129=-1500 ; -150°elec.			
I179=1500 I129=-3000 ; -90°elec.			
I179=3000 I129=-1500 ; -30°elec.			

```
I179=P179   I129=P129           ; restore previous offsets after test
```

Hall Sensors at 0°, 120°, and 240°

```
P179=I179   P129=I129           ; store previous offsets before test
#1o0                ; Open loop command of zero magnitude
```

Six Step Method	U (Mx26)	V(Mx25)	W(Mx24)
I179=3000 I129=0 ; 0°elec.			
I179=0 I129=3000; 60°elec.			
I179=-3000 I129=3000; 120°elec.			
I179=-3000 I129=0 ; 180°elec.			
I179=0 I129=-3000 ; -120°elec.			
I179=3000 I129=-3000; -60°elec.			
I179=3000 I129=0 ; 0°elec.			

```
I179=P179   I129=P129           ; restore previous offsets after test
```

Commutation Phase Angle at 240° -> Ix72=171

Hall Sensors at 30°, 150°, and 270°

```
P179=I179   P129=I129           ; store previous offsets before test
#1o0                ; Open loop command of zero magnitude
```

Six Step Method	U (M126)	V(M125)	W(M124)
I179=1500 I129=1500; -30°elec.			
I179=3000 I129=-1500; 30°elec.			
I179=1500 I129=-3000; 90°elec.			
I179=-1500 I129=-1500; 150°elec.			
I179=-3000 I129=1500 ; -150°elec.			
I179=-1500 I129=3000 ; -90°elec.			
I179=1500 I129=1500 ; -30°elec.			

```
I179=P179   I129=P129           ; restore previous offsets after test
```

Hall Sensors at 0°, 120°, and 240°

```
P179=I179 P129=I129 ; store previous offsets before test
#1o0 ; Open loop command of zero magnitude
```

Six Step Method	U (Mx26)	V (Mx25)	W (Mx24)
I179=3000 I129=0 ; 0°elec.			
I179=3000 I129=-3000 ; 60°elec.			
I179=0 I129=-3000; 120°elec.			
I179=-3000 I129=0 ; 180°elec.			
I179=-3000 I129=3000 ; -120°elec.			
I179=0 I129=3000 ; -60°elec.			
I179=3000 I129=0 ; 0°elec.			

```
I179=P179 I129=P129 ; restore previous offsets after test
```

Now that the transitions have been mapped out for the sections of the electrical cycle, define and calculate the Hall Effect Zero (HEZ).

Note:

Remember to clear the offsets when finished with this test.

Hall Effect Zero (HEZ) – The Hall Effect Zero is the location in the electrical cycle when U is low (value of 0), W is high (value of 1), and V changes state either from 1 to 0 or from 0 to 1.

See the following diagram as an example:

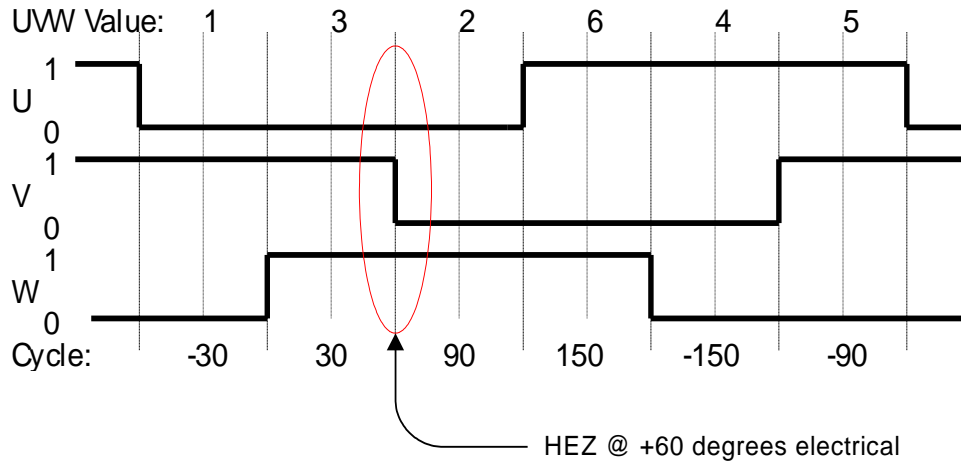

The offset can be computed using the mapping test shown above. In the example, the Hall Effect Zero (HEZ) point was found to be between +30°e and +90°e, so it is called +60°e. The offset value can be computed as:

$$Offset = \frac{HEZ \% 360^{\circ}}{360^{\circ}} * 64$$

The offset computed here should be rounded to the nearest integer.

In the example, this comes to:

$$Offset = \frac{+60^{\circ} \% 360^{\circ}}{360^{\circ}} * 64 = \frac{60^{\circ}}{360^{\circ}} * 64 = 10.667 \approx 11 = \$0B \text{ hex}$$

Find the Hall Effect Zero and record it for use in setting up Ix81.

Hall Effect Zero	
-------------------------	--

Determining the Polarity of the Hall Effects – Standard or Reversed

The polarity of the Hall Effects can be determined from the chart recorded in the previous section in the Current Loop 6-step procedure. The polarity depends on how the motor leads were connected with respect to the encoder direction as well as how it was wired in the hall effects with respect to the electrical cycle (in other words the U and V wires were swapped).

Standard Polarity – if the current loop 6-step is being executed in the positive direction of the electrical cycle (from -30 to 30, 90, 150, -150, -90, -30 or 0 to 60, 120, 180, -120, -60,0), the system is considered to have a standard Hall Effect polarity if the transition of V at the Hall Effect Zero is from 0 to 1.

Reversed Polarity - if the current loop 6-step is being executed in the positive direction of the electrical cycle (from -30 to 30, 90, 150, -150, -90, -30 or 0 to 60, 120, 180, -120, -60,0), the system is considered to have a reversed Hall Effect polarity if the transition of V at the Hall Effect Zero is from 1 to 0.

Refer to the chart below as an example:

An easy method to determine if the hall effects are standard or reversed (setting bit 22 for Ix81) would be to look at the data in columns.

Ix79	Ix29	Electrical Cycle	U	V	W	Positive ↑	The HEZ occurs at 60° electrical. If the transition of V from 0 to 1 at the HEZ point is in the negative direction (like this example), then the hall effect sensing would be considered reversed. If the transition of V from 0 to 1 at the HEZ is in the positive direction, then the hall effect sensing would be considered standard.
3000	-1500	-30	0	1	0		
1500	-3000	-90	1	1	0		
-1500	-1500	-150	1	0	0		
-3000	1500	150	1	0	1		
-1500	3000	90	0	0	1		
1500	1500	30	0	1	1		
3000	-1500	-30	0	1	0		

Record whether the Hall Effects are setup as standard or reversed and move on to the next step of setting up the Controller setup parameters for Hall Effect Power on Phasing.

Software Settings for Hall Effect Phasing

The variable used for Hall Effect Phasing is Ix81. This variable is the Power on-phasing setup register. To enable a Hall Effect Phasing on power up, configure Ix81 properly and then enable the power on feature by setting Ix80=1. The default of Ix80 is 0 and then a phasing search will be activated only by the \$ command. It is recommended that the phasing search is set up and tested with the aid of this document and verified through the \$ command before enabling the power on phasing routine with Ix80.

Note:

If Ix73 and Ix74 have a value greater than zero, then the automatic hall phasing routines will not work. Ix73 and Ix74 are used for the automatic step phase method.

Software Setup

Hall Effect Phasing on Geo PMACs is set up through Ix81. Ixx81 contains address information for the Hall Effect Data as well the phasing mode, HEZ and polarity information of the Hall Effect Sensors.

Ix81 Hall Effect Setup for Turbo Ultralite with the Geo MACRO Drive

Hex (\$)	C				B				C				0				0				0			
Bit	23	22	21	20	19	18	17	16	15	14	13	12	11	10	9	8	7	6	5	4	3	2	1	0
Value	1	1	0	0	1	0	1	1	1	1	0	0	0	0	0	0	0	0	0	0	0	0	0	0

- Bit 23 This bit is always set to 1 to tell PMAC to turn on Hall Effect Phasing
- Bit 22 Hall Effect Polarity- 0 for standard and 1 for reversed
- Bits 16-21 HEZ in Hexadecimal format, see section 5 above.
- Bits 0-15 Reserved

Example:

For a PMAC2 on Axis 1 using Hall Effects with a Hez of 60°e and reversed polarity the setting would be:

$$Offset = \frac{+60^\circ \% 360^\circ}{360^\circ} * 64 = \frac{60^\circ}{360^\circ} * 64 = 10.667 \approx 11 = \$0B \text{ hex}$$

I181= \$800000 + \$400000 + \$0B0000 + \$00C000 = \$CBC000

Optimizing the Hall Effect Phasing Routine for Maximum Performance

Typically, since there are only three Hall Sensors, the accuracy of phase referencing is good to +/-30° of the commutation cycle, which is enough to get reasonable torque and reasonable smoothness without any phasing search. However, it is recommended to more accurately update your phase position register during the home routine for a particular axis. Since the index pulse is a fixed global reference to the electrical cycle 0 and it is often used in homing routines, the home routine presents a perfect opportunity to optimize the phasing of a motor.

An excellent (and recommended) method of phasing a motor is to use the Halls on power up and then write a value into the phase position register after homing. We have already discussed how to set up the Halls as a power on phasing routine. To execute a fine phasing routine as part of the home routine follow the procedure below.

- **Manually step-phase the motor**

Exercise caution, as a manual step phasing routine will jerk the motor into electrical zero. The distance of the jerk will depend on the number of poles on the motor as well any coupling that may be attached to the motor.

To Manually step phase axis 1 execute the following routine:

```
P179=I179    P129=I129            ;store current offsets
#1o0                                ;Enable the amplifier
I179=3000    I129=0                ;force motor into Electrical Zero
M171=0                               ;zero the phase position register
I179=P179    I129=P129            ;reset current offsets
```

After performing a step-phasing routine the motor will be phased as accurately as possible.

- **Perform a Home search move using the index pulse**

Execute a home search move using the index pulse or move the motor to the index pulse using an oscilloscope. Once the motor is at index pulse/home routine, record the phase position register value, Mx71, after the motor has settled into position. The value recorded will be the phase position reference whenever it is homed to an index pulse. It is recommended to store this value into Ix75. Ix75 is not used when a Hall Effect automatic phasing routine is enabled. To store this value into flash, make sure to issue a **SAVE** command.

- **Add fine phasing value as part of Home Routine**

As long as the home routine includes the index pulse as part of the trigger, write the stored value of Ix75 (from the previous step) to the phase position register after the routine is finished. Therefore, on power up, the Hall effect will provide the phasing to enable the motor move through homing routine. After the homing routine is finished, then the phase position register should be updated with a more value than given from the Halls.

Example:

Homing PLC:

```
open plc11 clear
I912=3
I913=0
cmd"#1hm"
while (m140!=0)           ;M140 is in-position bit- suggested m-var
endwhile
M171=I175
close
```

- **Other Cases**

Not all applications will be using the index pulse as part of a homing routine. It is okay to use another global fixed position as a fine phasing reference. As long as the position chosen is fixed with respect to the motor's position. Use the same procedure as described above to find the phase position value at that fixed position. First step phase the motor, then move the motor to the desired home routine, let the motor settle, record the phase position and store it into Ix75. Then after homing check to make sure the motor is in-position and write the value into Mx71.

This document chose the index pulse to capitalize on the accuracy that PMAC's Gate Array has with respect to latching on the index pulse. Using the index pulse also allows a common value to be stuffed into Mx71 for different machines. Typically, motor manufacturers will mount the index in a repeatable manner with respect to the electrical cycle, although this cannot be guaranteed by Delta Tau. If not homing using the index pulse, then the value for Mx71 must be measured on every machine since it is dependent on the mounting of the motor to a coupling or the location of a home/limit switch.

Example:

PMAC2 in Direct PWM Commutation mode with Ix72=85 and Hall Sensors at 30°, 150°, and 270°

Step	M179	M129	Cycle Pos.	Physical Position	M101 (counts)	M126 (U)	M125 (V)	M124 (W)	M128 (TUVW)
1	+3000	-1500	-30°	3:30	-9001	0	1	0	2
2	+1500	-3000	-90°	2:30	-9343	1	1	0	6
3	-1500	-1500	-150°	1:30	-9673	1	0	0	4
4	-3000	+1500	+150°	12:30	-10030	1	0	1	5
5	-1500	+3000	+90°	11:30	-10375	0	0	1	1
6	+1500	+1500	+30°	10:30	-10709	0	1	1	3
1	+3000	-1500	-30°	9:30	-11050	0	1	0	2

Note:

If the T flag input is 1, the values of Mx28 will be eight greater than what is shown in the table.

Using the Test Results

To execute a power-on phasing using the hall-effect sensors, use new modes of the Ix81 power-on phase position parameter, or write a simple PLC program that executes once on power-up/reset.

Setting bit 23 of Ix81 to 1 specifies a hall-effect power-on phase reference. In this case, the address portion of Ix81 specifies a PMAC X-address, usually that of the flag register used for the motor, the same address as in Ix25.

PMAC expects to find the hall-effect inputs at bits 20, 21, and 22 of the specified register. In a flag register, these bits match the CHWn, CHVn, and CHUn inputs, respectively. Hall-effect inputs are traditionally labeled U, V, and W.

The hall-effect signals must each have a duty cycle of 50% (180°e). PMAC can use hall-effect commutation sensors separated by 120°e. There is no industry standard with hall-effect sensors as to direction sense or zero reference, so this must be handled with software settings of Ix81.

Bit 22 controls the direction sense of the hall-effect sensors as shown in the following diagrams, where a value of 0 for bit 22 is standard and a value of 1 is reversed:

This diagram shows the hall-effect waveforms with zero offset, defined such that the V-signal transition when the U-signal is low (defined as the zero point in the hall-effect cycle) represents the zero point in PMAC’s commutation cycle.

If the hall-effect sensors do not have this orientation, bits 16 to 21 of Ix81 can be used to specify the offset between PMAC’s zero point and the hall-effect zero point. These bits can take a value of 0 to 63 with units of 1/64 of a commutation cycle (5.625°e). Below is the hall effect waveform diagram constructed from the example.

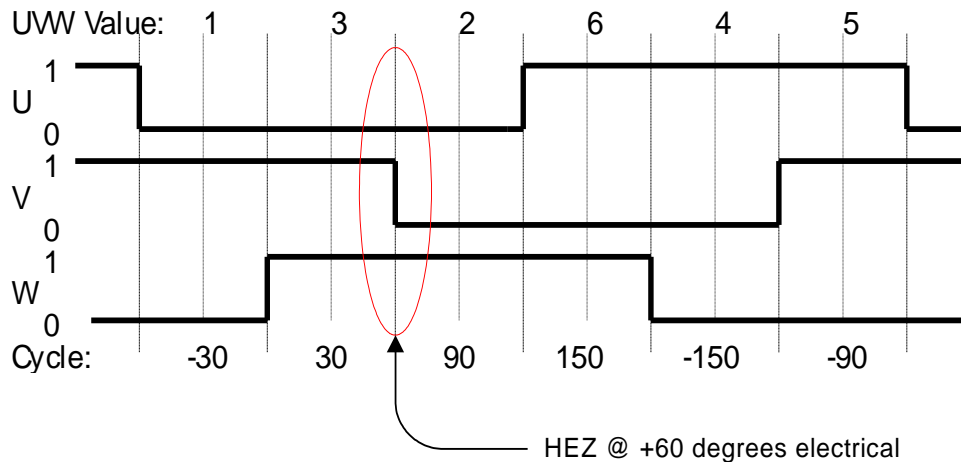

The offset can be computed using the mapping test shown above. In the example, the hall effect zero (HEZ) point was found to be between +30°e and +90°e, so we will call +60°e. The offset value can be computed as:

$$Offset = \frac{HEZ \% 360^{\circ}}{360^{\circ}} * 64$$

The offset computed here should be rounded to the nearest integer.

In the example, this comes to:

$$Offset = \frac{+60^{\circ} \% 360^{\circ}}{360^{\circ}} * 64 = \frac{60^{\circ}}{360^{\circ}} * 64 = 10.667 \approx 11 = \$0B \text{ hex}$$

The test showed that the hall-effect sensors were in the reversed direction, not standard, so bit 22 is set to

one. With bit 23 (a value of 8 in the first hex digit) set to 1 to specify hall effect sensing, the first two hex digits of Ix81 become \$CB. If Flag register 1 at address \$C000 were used for the hall-effect inputs, Ix81 would be set to \$CBC000.

An easy method to determine if the hall effects are standard or reversed (setting bit 22) would be to look at the data in columns.

Ix79	Ix29	Electrical Cycle	U	V	W	Positive ↑	The HEZ occurs at 60° electrical. If the transition of V from 0 to 1 at the HEZ point is in the negative direction (like this example), then the hall effect sensing would be considered reversed. If the transition of V from 0 to 1 at the HEZ is in the positive direction, then the hall effect sensing would be considered standard.
3000	-1500	-30	0	1	0		
1500	-3000	-90	1	1	0		
-1500	-1500	-150	1	0	0		
-3000	1500	150	1	0	1		
-1500	3000	90	0	0	1		
1500	1500	30	0	1	1		
3000	-1500	-30	0	1	0		

The description of Ix81 in the Software Reference shows the common values of offsets used, for all the cases where the zero point in the hall-effect cycle is at a 0°, 60°, 120°, 180°, -120°, or -60° point – where manufacturers generally align the sensors.

Ix81 Hall Effect Setup for Example 1

Hex (\$)	C				B				C				0				0				0			
Bit	23	22	21	20	19	18	17	16	15	14	13	12	11	10	9	8	7	6	5	4	3	2	1	0
Value	1	1	0	0	1	0	1	1	1	1	0	0	0	0	0	0	0	0	0	0	0	0	0	0

↑ Standard Hall Sense (0), Reversed Hall Sense (1)
 ↑ Hall Effect Type Phase (1)

{ Hall Effect Offset (\$0B)
 { Source Address (\$C000)

$Ix81 \text{ mask} = \$80 + \$40 + \$0B = \CB

For Geo PMAC axis #1, this would give us $I181 = \$CBC000$

Encoder Loss Setup

Geo PMAC controller has encoder-loss detection circuitry for each primary encoder input. Designed for use with encoders with differential line-driver outputs, the circuitry monitors each input pair with an exclusive-or (XOR) gate, for the quadrature encoder feedback. If the encoder is working properly and connected to the Geo PMAC, the two inputs of the pair should be in opposite logical states – one high and one low – yielding a true output from the XOR gate.

Note

A single-ended quadrature encoder cannot be used on the channel Encoder-Loss Errors

For the Geo PMAC Controller Encoder-loss detection bits come in the locations shown in the table below.

Channel#	Memory Address		Description
	Quadrature Feedback	Sinusoidal Feedback	
Encoder #1	Y:\$0994,3,1	Y:\$FFC3,10,1	Encoder #1 Loss Input Signal
Encoder #2	Y:\$0A54,3,1	Y:\$FFC3,11,1	Encoder #2 Loss Input Signal

As of this writing, there is no automatic action taken on detection of encoder loss. Users who want to take action on detecting encoder loss should write a PLC program to look for a change in the encoder loss bit and take the appropriate action. Generally, the only appropriate response is to kill (open loop, zero output, disabled) the motor with lost encoder feedback; other motors may be killed or aborted as well.

This next example program reacts to a detection of encoder loss. This is a more serious condition than a count error, so a “kill” command is issued when the loss is detected. The example is for a single axis only, but is easy to duplicate for multiple axes.

```
; Substitutions and definitions
#define MtrlOpenLoop      M138      ; Motor status bit
MtrlOpenLoop->Y:$003D,18,1      ; Standard definition
#define EnclLossIn        M180      ; Input loss-detection bit
EnclLossIn->Y:$0994,3,1          ; Geo PMAC Ch1 loss bit
#define MtrlEncLossStatus P180      ; Internal latched status
#define Lost              0         ; Low=true fault here
#define OK                1         ; High is encoder present
; Program (PLC) to check for and react to encoder loss
OPEN PLC 18 CLEAR
; Logic to disable and set fault status
IF (MtrlOpenLoop=0 AND EnclLossIn=Lost)      ; Closed loop, no enc
    CMD^K                                     ; Kill all motors
    MtrlEncLossStatus=1                       ; Indicate encoder loss
ENDIF
; Logic to clear fault status
IF (MtrlOpenLoop=1 AND EnclLossIn=OK AND MtrlEncLossStatus=0)
    MtrlEncLossStatus=0                       ; Indicate valid encoder signal
ENDIF
CLOSE
```

For more details about Encoder Loss look into the PMAC USERS Manual chapter: *Making Your Application Safe*.

Program Accessible Amplifier Status Codes

If the user wants another way to monitor the status of the Geo PMAC drive rather than the 7-segment display, use PLC/PLCC to check on the lower 7-bits of the memory register Y:\$FF5C,8,8

Display	Value	Description
0	3F	Normal Operation
1	6	I ² T Current Fault – Axis 1
2	5B	Instantaneous Over Current Fault – Axis 1
3	4F	De-saturation Fault – Axis 1
4	6C	IGBT Over Temp - Axis 1 Fault
5	6D	Motor Over Temp - Axis 1 Warning
6	7D	I ² T Current Fault – Axis 2
7	7	Instantaneous Over Current - Axis 2 Fault
8	7F	De-saturation fault – Axis 2 Fault
9	67	IGBT Over Temp - Axis 2 Fault
A	77	Motor Over Temp - Axis 2 Warning
b	7C	Over Voltage Fault
C	39	Under Voltage Fault
d	5E	Shunt PWM Fault
F	71	Gate Driver Voltage Fault
L		Line Motor Fault

An example piece of code to monitor these status codes is:

```
M999->Y:$FF5C,8,8
```

```
...
```

```
IF (M999&$7F !=3F)      ;if the status is not equal to Normal Operation then there
                        ; is a fault.
```

```
...
```

DIRECT PWM COMMUTATION CONTROLLER SETUP

The Geo PMAC amplifier must have the proper controller setup to command the amplifier/motor system. This section summarizes the key variables for the Geo PMAC which uses a Non Turbo PMAC2 controller that would have to be modified for use with the amplifier. The Delta Tau setup software such as PMAC2 Setup or Geo PMAC Setup will help set these parameters for the system automatically. For details about direct commutation of brushless and induction motors, read the PMAC2 User Manual. To find out the details about these variables, refer to the PMAC and PMAC2 Software Reference Manual.

Key Servo IC Variables

Geo PMAC	Type	Description
I900	Clock	Max phase clock setting
I901	Clock Divisor	Phase clock divisor
I902	Clock Divisor	Servo clock divisor
I903	Clock	Hardware clock settings
I904	Clock	PWM dead time
I905	Strobe	DAC strobe word
I9n0	Channel	Encoder decode for channel
I9n6	Channel	Output mode for channel (Must be set to 0.)
<p>* To change the ADC strobe word for a non-Turbo PMAC2 controller, issue a write command directly to the memory location of the Gate array channel connected to the amplifier. For Geo PMAC channel 1-4, use memory location X:\$C014 For example: WX:\$C014,\$1FFFFFF</p>		

Key Motor Variables

Caution:

The ADC Strobe Word, X:\$C014 (non-Turbo PMAC2) must be set to \$1FFFFFF for proper operation. Failure to set the ADC strobe word equal to \$1FFFFFF could result in damage to the amplifier.

Geo PMAC	Type	Description
Ix00	General	Motor enable
Ix01	General	Commutation enable
Ix25	General	Motor flag setup
Ix70	Commutation	Number of commutation cycles per Ix71
Ix71	Commutation	Counts per commutation cycle per Ix70
Ix72	Commutation	Commutation phase angle
Ix77	Commutation	Induction motor magnization current
Ix78	Commutation	Induction motor slip gain
Ix83	Commutation	On-going phase position
Ix61	Current Loop	Current loop integrator gain
Ix62	Current Loop	Current loop forward path proportional gain
Ix66	Current Loop	PWM scale factor
Ix76	Current Loop	Current loop back bath proportional gain
Ix82	Current Loop	Current loop feedback address
Ix84	Current Loop	Current loop feedback ADC mask word
Ix57	I ² T	Continuous limit for I2T
Ix58	I ² T	Integrated current limit

DC BRUSH MOTOR DRIVE SETUP

It is possible to use PMAC2's direct PWM and digital current loop for control of permanent magnet DC brush motors. Because PMAC2's digital current loop and commutation algorithms are combined, it is necessary to activate PMAC2's commutation algorithm for the motor, even though it is not commutating the motor.

A few special settings must be made to use the direct-PWM algorithms for DC brush motors. The basic idea is to trick the commutation algorithm into thinking that the commutation angle is always stuck at 0 degrees, so current into the A phase is always quadrature (torque-producing) current. This section summarizes what must be done in terms of variable setup.

The sinusoidal commutation is effectively disabled in this technique by telling PMAC2 that the motor has no commutation cycles ($Ix70=0$). Each count received is multiplied by zero, leaving the phase angle constant at all times for DC control. With the phase angle always at zero, PMAC2's quadrature, or torque-producing, output voltage and feedback current are always equivalent to the motor's rotor, or armature, voltage and current. PMAC2's direct, or magnetization field, voltage and current are always equivalent to the motor's stator, or wound field, voltage and current (if any).

These instructions assume:

- The brush motor's rotor field comes from permanent magnets or a wound field excited by a separate means; the field is not controlled by one of the phases of this channel.
- The two leads of the brush motor's armature are connected to amplifier phases (half-bridges) that are driven by the A and C-phase PWM commands from Turbo PMAC. The amplifier may have an unused B-phase half-bridge, but this does not need to be present.

I-Variable Setup

Settings that are the same as for permanent-magnet brushless servo motors with an absolute phase reference::

- $Ix01 = 1$ (commutation directly on Geo PMAC)
- $Ix02$ should contain the address of the PWM A register for the output channel used (these are the defaults), just as for brushless motors.
- $Ix29$ and $Ix79$ phase offset parameters should be set to minimize measurement offsets from the A and B-phase current feedback circuits, respectively.
- $Ix61$, $Ix62$, and $Ix76$ current loop gains are set just as for brushless motors.
- $Ix73 = 0$, $Ix74 = 0$: These default settings ensure that PMAC will not try to do a phasing search move for the motor. A failed search could keep PMAC from enabling this motor.
- $Ix77 = 0$ to command zero direct (field) current.
- $Ix78 = 0$ for zero slip in the commutation calculations.
- $Ix82$ should contain the address of ADC B register for the feedback channel used (just as for brushless motors) when the ADC A register is used for the rotor (armature) current feedback. The B register itself should always contain a zero or near-zero value.
- $Ix81 > 0$: Any non-zero setting here makes PMAC do a "phasing read" instead of a search move for the motor. This is a dummy read, because whatever is read is forced to zero degrees by the settings of $Ix70$ and $Ix71$, but PMAC demands that some sort of phase reference be done. ($Ix81=1$ is fine.)

Special settings for brush motor direct PWM control:

- $Ix70 = 0$: This causes all values for the commutation cycle to be multiplied by 0 to defeat the rotation of the commutation vector.
- $Ix72 = 512$ ($90^\circ e$) if voltage and current numerical polarities are opposite, or 1536 ($270^\circ e$) if they are the same. If the amplifier would use 683 ($120^\circ e$) for a 3-phase motor, use 512 here; if it would use 1365 ($240^\circ e$) for a 3-phase motor, use 1536 here.

Settings that do not matter:

- Ix71 (commutation cycle size) does not matter because Ix70 setting of 0 defeats the commutation cycle
- Ix75 (Offset in the power-on phase reference) does not matter because commutation cycle has been defeated. Leaving this at the default of 0 is fine.
- Ix83 (ongoing commutation position feedback address) doesn't matter, since the commutation has been defeated. Leaving this at the default value is fine.
- Ix91 (power-on phase position format) does not matter, because whatever is read for the power-on phase position is reduced to zero.

Ideally, the ADC B for the channel would always report zero current. However, because of noise and circuit offsets, this will not be true exactly. Because of the current-loop integral gain, over time the integrator for the direct current loop can charge up to the point where it interferes with normal operation. To prevent this, the different current integrator register must be cleared periodically using a background PLC program.

If these two M-variables are defined:

M178->Y:\$0046,0,24,s ;motor #1 Id integrator

M278->Y:\$0082,0,24,s ;motor #2 Id integrator

Then the following two lines can be placed in any background PLC program that is always executing:

M178=0

M278=0

Hardware Connection

In this technique, the rotor (armature) current is commanded by PMAC2 phases A and C. The motor armature leads should be connected between the two half-bridges of the amplifier driven by PMAC2 phases A and C, together forming a full H-bridge.

The armature current sensor feeds an A/D converter that is connected to the serial ADC A inputs for the channel on PMAC2. The B phase output on the Geo Drive is left unconnected and there will be no current flowing through the current sensor.

Note:

When the setup program requests the DC bus Voltage, and you use AC input for the Bus, the value is your ACbus x SQRT(2)
For example 230VAC bus would be 325VDC.

SETTING I²T PROTECTION

It is important to set the I²T protection for the amplifier/motor system for PMAC2 direct PWM commutation. Normally, an amplifier has internal I²T protection because it is closing the current loop. When PMAC2 is closing the current loop, the amplifier cannot protect itself or the motor from over heating. Either set up the I²T protection using one of the Setup Programs or manually set the Ix69, Ix57 and Ix58 variables based on the following specifications:

Parameter	Description	Notes
MAX ADC Value	Maximum Current output of amplifier relative to a value of 32767 in Ix69	GIx012xx = 7.3 A Peak GIx032xx = 14.6A Peak GIx05xxx = 16.3A Peak GIx10xxx = 32.5A Peak GIx15xxx = 48.8A Peak GIx201xx = 65 A Peak GIx301xx = 97.6A Peak x = Position in part number is irrelevant.
Instantaneous Current Limit	The lower of the amplifier or motor system	RMS or Peak*
Continuous Current Limit	The lower of the amplifier or motor system	Usually RMS
I ² T protection time	Time at instantaneous limit	Usually two seconds
Magnetization Current	Ix77 value for induction motors	Only for induction motors
Servo Update Frequency	Default is 2258 Hz.	

* If specification given in RMS, multiply with x1.41 to obtain peak current for calculations.

Example Calculations for Direct PWM commutated motor:

MAX ADC = 32.5A

Instantaneous Current Limit = 10A Peak

Continuous Current Limit = 5A RMS

I²T protection time = 2 seconds

Magnetization Current (Ix77) = 0

Servo Update = 2.258 kHz

$$Ix69 = \frac{Instantaneous\ Limit(Peak)}{MAX\ ADC} \times 32767 \times \cos(30^\circ)$$

if calculated Ix69 > 32767, then Ix69 should be set equal to 32767

$$Ix57 = \frac{Continuous\ Limit}{Instantaneous\ Limit} \times Ix69$$

$$Ix58 = \frac{Ix69^2 + Ix77^2 - Ix57^2}{32768^2} \times ServoUpdateRate(Hz) \times PermittedTime(seconds)$$

Based on the above data and equations, the following results:

Ix69= 8731

Ix57=4366

Ix58=240

For details about I²T protection, refer to the safety sections of the User Manual. Details about the variable setup can be found in the Software Reference manual.

CALCULATING MINIMUM PWM FREQUENCY

The minimum PWM frequency requirement for a system is based on the time constant of the motor. Calculate the minimum PWM frequency to determine if the amplifier will properly close the current loop. Systems with very low time constants need the addition of chokes or in-line inductive loads to allow the PMAC to properly close the current loop of the system. In general, the lower the time constant of the system, the higher the PWM frequency must be.

Calculate the motor time constant by dividing the motor inductance by the resistance of the phases.

$$\tau_{motor} = \frac{L_{motor}}{R_{motor}}$$

The relationship used to determine the minimum PWM frequency is based on the following equation:

$$\tau > \frac{20}{2\pi \times PWM (Hz)}$$

$$\therefore PWM (Hz) > \frac{20}{2\pi\tau}$$

Example:

$$L_{motor} = 5.80 \text{ mH}$$

$$R_{motor} = 11.50 \Omega$$

$$\tau_{motor} = \frac{5.80mH}{11.50\Omega} = 0.504m \text{ sec}$$

$$\text{Therefore, } PWM (Hz) = \frac{20}{2\pi \times (0.504m \text{ sec})} = 6,316 \text{ Hz}$$

Based on this calculation, set the PWM frequency to at least 6.32kHz.

TROUBLESHOOTING

Error Codes

In most cases, the Geo PMAC Drive communicates error codes with a text message via the USB/Ethernet port to the host. Some error codes are also transmitted to the Status Display. Not all errors reflect a message back to the host. In these cases, the no-message errors communicate only to the Status Display.

The response of the Geo Drive to an error depends on the error's severity. There are two levels of severity:

1. Warnings (simply called errors and not considered faults and do not disable operation).
2. Fatal errors (fatal faults that disable almost all drive functions, including communications).

Note:

The Geo Drive automatically disables at the occurrence of a fault.

D1: AMP Status Display Codes

The 7-segment display on the current model provides the following codes:

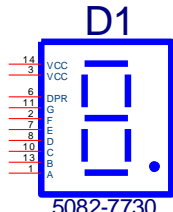
7-segment LED		
Display	Description	Notes/Cause
0	Normal Operation	Normal operation with decimal point blinking
1	I ² T Current Fault – Axis 1	An internal timer has noticed that Axis 1 is taking more RMS current than the drive was designed to produce. Reduce loading.
2	Instantaneous Over Current Fault – Axis 1	Over current sensors have detected an excess of current through the motor leads. Typically, bad setup information (check Ix69) or overshoots in the current loop, or voltage commands from the controller through the power stage.
3	De-saturation Fault – Axis 1	Short circuit in output. Check Motor wires to each other and GND. If problem persists or happens when no output wires are connected, return drive for repairs, RMA.
4	IGBT Over Temp - Axis 1 Fault	Make certain ambient temperature does not exceed 45C
5	Motor Over Temp - Axis 1 Warning	Normally closed input on the front of the Geo drive amplifier connector X1. Motor over Temp is detected in open circuit. To disable this function, ground (pin 13/25) to pin 23 (temp input). For newer versions (1.17C and above) use I1013
6	I ² T Current Fault – Axis 2	An internal timer has noticed that Axis 1 is taking more RMS current than the drive was designed to produce. Reduce loading.
7	Instantaneous Over Current - Axis 2 Fault	Over current sensors have detected an excess of current through the motor leads. Typically, bad setup information (check Ix69) or overshoots in the current loop, or voltage commands from the controller through the power stage.
8	De-saturation fault – Axis 2 Fault	Short circuit in output. Check Motor wires to each other and GND. If problem persists or happens when no output wires are connected, return drive for repairs, RMA.
9	IGBT Over Temp - Axis 2 Fault	Make certain ambient temperature does not exceed 45C
A	Motor Over Temp - Axis 2 Warning	Normally closed input on the front of the Geo drive amplifier connector X2. Motor over Temp is detected in open circuit. To disable this function ground (pin 13/25) to pin 23 (temp input). For newer versions (1.17C and above) use I1013

b	Over Voltage Fault	The bus voltage has exceeded a factor pre-set threshold of 820V for 480V drives or 420V for 230V drives. Lack of ability to dump the regenerated energy from the motor. A shunt regulator or dump resistor can help GAR48 or GAR78. Another common cause can be excessively high input line voltage.
C	Under Voltage Fault	The DC bus internal to the Geo drive has decreased below a factory pre-set threshold of 16 to 30Vdc (no AC input power to the drive).
d	Shunt PWM Fault	Excessive shunt regulator current fault. Check wiring to the shunt regulator resistor to ensure that no short across the resistor or to ground exists. Do not reset drive for at least 60 seconds.
F	Gate Driver Voltage Fault	Gate power (+20V) was not detected. This fault can occur if the outputs are shorted and the mains for the DC bus are not on. Check output wiring; ensure no shorts exist from wire to wire or from any wire to ground.
L	Line Motor Fault	Check the 3 phase voltage

Status LEDs

Status Display	Color	Description
7-segment LED	Red	16 numeric codes plus two decimal points
GATE ENABLE	Green	Lit when Gate is Enabled
DC BUS	Dim Red	Lit when bus powered.
USB	Green	Lit when USB cable is plugged in
REG	Yellow	Lit when drive is attempting to dump power through the external shunt regulator regen resistor.
+5V	Green	Lit when 5V logic has power.
WD	Red	Lit when Watchdog is tripped
+3.3V	Green	Lit when 3.3V logic has power

APPENDIX A

Mating Connector and Cable Kits

Cable sets can be purchased directly from Delta Tau to make the wiring of the system easier. Available cable kits (CABKITxx) are listed below.

However, for those manufacturing their own cable sets, the table below provides Connector Kits to use with each drive. Connector Kits (CONKITxx) include the MOLEX connectors and pins for the AC input, 24VDC power supply and the motor outputs.

Note:

Due to the variety and wide availability of D-type connectors and back shells, CABKITs and CONKITs do not provide these connectors and back shells.

Cable kits have terminated cables on the drive end and flying leads on the other

Mating Connector and Cable Kits

Geo Drives do not come with any connectors for the AC input, 24VDC input, Regen Resistor Output, or Motor Outputs. The user should purchase the appropriate Mating Connector and Cable Kits from Delta Tau Data Systems, Inc., or they can obtain the connectors and pins from other sources.

Cable sets can be purchased directly from Delta Tau to make the wiring of the system easier. Available cable kits (CABKITxx) are listed below.

For those manufacturing their own cable sets, the table below provides Connector Kits to use with each drive. Connector Kits (CONKITxx) include the MOLEX connectors and pins for the AC input, 24VDC power supply and the motor outputs.

Note:

Due to the variety and wide availability of D-type connectors and back shells for the encoders, CABKITs and CONKITs do not provide these parts.

For correct installation of the connector kit to the Cables, proper crimping tools are required. Check the Molex website to find the correct tool for the appropriate pin.

Cable kits have terminated cables on the drive end and flying leads on the other.

Mating Connector and Cable Kits

Connector Kit	Description
CONKIT1A	Mating Connector Kit for dual axis drives up to 5-amp continuous rating (Gxx012xx, Gxx032xx, Gxx052xx, GxL102xx): Includes Molex Connectors kits for two motors, AC input connection, and 24V power connection. Requires Molex Crimp tools for proper installation.
CABKIT1B	Includes Molex mating connectors pre-crimped for dual axis drives up to 5-amp continuous rated (Gxx012xx, Gxx032xx, Gxx052xx, GxL102). <ul style="list-style-type: none"> • 3 ft. AC Input Cable • 3 ft. 24VDC Power Cable • 10 ft. shielded Motor Cables
CONKIT1C	Mating Connector Kit for single axis drives up to 5-amp continuous rating (Gxx051xx): Includes Molex Connectors kits for two motors, AC input connection, and 24V power connection. Requires Molex Crimp tools for proper installation.

CABKIT1C	Includes Molex mating connectors pre-crimped for single axis drives up to 5-amp continuous rated (Gxx051xx). <ul style="list-style-type: none"> • 3 ft. AC Input Cable • 3 ft. 24VDC Power Cable • 10 ft. shielded Motor Cables
CONKIT2A	Mating Connector Kit for dual axis drives up to 15 amp continuous rating (GxH102xx, Gxx152xx): Includes Molex Connectors kits for: two motors, AC input connection, and 24V power connection. Requires Molex Crimp Tools for proper installation.
CABKIT2B	Includes Molex mating connectors pre-crimped for dual axis drives (double width) up to 15 amp continuous rated (GxH102xx, Gxx152xx). <ul style="list-style-type: none"> • 3 ft. AC Input Cable • 3 ft. 24VDC Power Cable • 10 ft. shielded Motor Cables
CONKIT2C	Mating Connector Kit for single axis drives, up to 15 amp continuous rating (Gxx101xx, Gxx151xx): Includes Molex Connectors kits for one motor, AC input connection, and 24V power connection. Requires Molex Crimp tools for proper installation.
CABKIT2D	Includes Molex mating connectors pre-crimped for single axis drives up to 15 amp continuous rated (Gxx101xx, Gxx151xx). <ul style="list-style-type: none"> • 3 ft. AC Input Cable • 3 ft. 24VDC Power Cable 10 ft. shielded Motor Cables
CONKIT4A	Mating Connector Kit for single axis drives up to 30 amp continuous rating (Gxx201xx, Gxx301xx): Includes Molex Connectors kits for one motor (4pin), AC input connection (4 pin), and 24V power connection. Requires Molex Crimp Tools for proper installation.
CABKIT4B	Includes Molex mating connectors pre-crimped for single axis drives up to 30 amp continuous rated (Gxx201xx, Gxx301xx). <ul style="list-style-type: none"> • 3 ft. AC Input Cable (4pin) • 3 ft. 24VDC Power Cable 10 ft. shielded Motor Cables (4 pin)
G14AWG	Motor Power Cables. Extended cable length. Per foot per cable for the CABKITS. Customer must specify length. For drives up to 15 amp continuous rating.(Gxx051xx, Gxx101xx, Gxx151xx, Gxx012xx, Gxx032xx, Gxx052xx, Gxx102xx, Gxx152xx)

Connector and Pins Part Numbers

CONKIT1A

Connector	D/T part number	D/T part number individuals	Molex part number
24VDC & Shunt Resistor	200-000F02-HSG	Housing: 014-000F02-HSG Pins: 014-043375-001	44441-2002 43375-0001
Motor (x2) 3pins	200-000F03-HSG	Housing: 014-000F03-HSG Pins: 014-043375-001	44441-2003 43375-0001
AC Input	200-H00F03-049	Housing: 014-H00F03-049 Pins: 014-042815-0031	42816-0312 42815-0031

CONKIT1C

Connector	D/T part number	D/T part number individuals	Molex part number
24VDC & Shunt Resistor	200-000F02-HSG	Housing: 014-000F02-HSG Pins: 014-043375-001	44441-2002 43375-0001
Motor (x1) 3pins	200-000F03-HSG	Housing: 014-000F03-HSG Pins: 014-043375-001	44441-2003 43375-0001
AC Input	200-H00F03-049	Housing: 014-H00F03-049 Pins: 014-042815-0031	42816-0312 42815-0031

CONKIT2A

Connector	D/T part number	D/T part number individuals	Molex part number
24VDC & Shunt Resistor	200-000F02-HSG	Housing: 014-000F02-HSG Pins: 014-043375-001	44441-2002 43375-0001
Motor (x2) 3pins	200-H00F03-049	Housing: 014-H00F03-049 Pins: 014-042815-0031	42816-0312 42815-0031
AC Input	200-H00F03-049	Housing: 014-H00F03-049 Pins: 014-042815-0031	42816-0312 42815-0031

CONKIT2C

Connector	D/T part number	D/T part number individuals	Molex part number
24VDC & Shunt Resistor	200-000F02-HSG	Housing: 014-000F02-HSG Pins: 014-043375-001	44441-2002 43375-0001
Motor (x1) 3pins	200-H00F03-049	Housing: 014-H00F03-049 Pins: 014-042815-0031	42816-0312 42815-0031
AC Input	200-H00F03-049	Housing: 014-H00F03-049 Pins: 014-042815-0031	42816-0312 42815-0031

CONKIT4A

Connector	D/T part number	D/T part number individuals	Molex part number
24VDC	200-000F02-HSG	Housing: 014-000F02-HSG Pins: 014-043375-001	44441-2002 43375-0001
Shunt Resistor	200-H00F03-049	Housing: 014-H00F03-049 Pins: 014-042815-0031	42816-0312 42815-0031
Motor (x1) 4pins	200-H00F04-049	Housing: 014-H00F04-049 Pins: 014-042815-0031	42816-0412 42815-0031
AC Input	200-H00F04-049	Housing: 014-H00F04-049 Pins: 014-042815-0031	42816-0412 42815-0031

Cable Drawings

THIS DRAWING IS THE CONFIDENTIAL PROPERTY OF DELTA TAU DATA SYSTEMS INC. AND IS LOANED SUBJECT TO RETURN UPON REQUEST. IT IS NOT TO BE REPRODUCED OR TRANSMITTED IN ANY MANNER. THIS DOCUMENT IS TO BE USED ONLY PURSUANT TO WRITTEN INVOICE OR WRITTEN INSTRUCTIONS OF DELTA TAU DATA SYSTEMS INC. ALL RIGHTS TO PATENTS AND PROPRIETARY INFORMATION ARE RESERVED BY DELTA TAU DATA SYSTEMS INC. THIS DOCUMENT INDICATES ACCEPTANCE OF THE ABOVE AGREEMENT.

TABULATION	
-XXXX	DESCRIPTION
-0030	3 FEET

REVISIONS			
REV.	DESCRIPTION	DATE	CHGD APPROVED
--	NEW DRAWING RELEASE	11-27-02	N.G. BILL K.
-A	ADDED TWISTING & 16 AWG WAS. 12	2-07-03	N.G. BILL K.

NOTES: UNLESS OTHERWISE SPECIFIED

- PART NOS. ARE INTERPRETED AS FOLLOWS:
 THE FIRST 3 DIGITS OF THE SUFFIX DENOTES LENGTH AND THE LAST DIGIT OF THE SUFFIX DENOTES REVISION LEVEL. ALL LENGTHS ARE SPECIFIED IN INCHES.
 200-603752-0241 IS A REVISION 1 CABLE AND IS 24 FEET LONG.
- CABLE/HARNESS ASSEMBLIES TO BE MADE WITH UL RECOGNIZED COMPONENTS AND LABELED UNDER WIRING HARNESS PROGRAM ZPFW2 AND MEET CSA STANDARD 22:2 ND0-M1982.
- CABLE TO BE IDENTIFIED WITH PART NUMBER AND REVISION USING BLACK INDELIBLE INK PRINTED ON LABEL. LABEL TO BE PERMANENTLY ATTACHED TO CABLE.

PARTS LIST	
SEQ	DESCRIPTION
10	1 RECEPTACLE, TERMINAL HOUSING 2 PIN (MOLEX P/N 4444J-2002)
20	2 CRIMP TERMINAL (MOLEX P/N 43375-0001)
30	XX FT WIRE, BLACK 16 AWG, (ANIXTER P/N 1015-16/26-0)
40	XX FT WIRE, RED 16 AWG, (ANIXTER P/N 1015-16/26-2)

WIRE	DCO-DRIVES	DELTA TAU DATA SYSTEMS, INC.
RECEPT	MULTIPLE ASSY	CABLE ASSY, 24 VDC INPUT,
WIRE GAUGE	AWG	APPLICABLE TO ALL MODELS
WIRE	NICK A. GOMEZ H-27-02	
DRIVER		
TRASH	SEE B/M	SIZE DWG. NO. 200-603752
	SEE B/M	DRAW. NO. -XXX0 A
	DO NOT SCALE DRAWING	SCALE NONE
		SHEET 1 OF 1

REVISIONS			
REV.	DESCRIPTION	DATE	CHGD. APPROVED
1-	CHANGED FROM P/N # TO U/VW	1-03-05	N.G. BRAD L.

TABULATION	
-XXXX	DESCRIPTION
-0100	10 FEET
-0200	20 FEET

NOTES: UNLESS OTHERWISE SPECIFIED

- PART NOS. ARE INTERPRETED AS FOLLOWS:
 THE FIRST 3 DIGITS OF THE SUFFIX DENOTES LENGTH AND THE LAST DIGIT OF THE SUFFIX DENOTES REVISION LEVEL. ALL LENGTHS ARE SPECIFIED IN INCHES.
 200-603739-0241 IS A REVISION 1 CABLE AND IS 24 FEET LONG.
- CABLE/HARNESS ASSEMBLIES TO BE MADE WITH UL RECOGNIZED COMPONENTS AND LABELED UNDER WIRING HARNESS PROGRAM ZPFW2 AND MEET CSA STANDARD 222 ND0-H1982.
- CABLE TO BE IDENTIFIED WITH PART NUMBER AND REVISION USING BLACK INDELEBILE INK PRINTED ON LABEL. LABEL TO BE PERMANENTLY ATTACHED TO CABLE.

PARTS LIST		
SEQ	QTY	DESCRIPTION
10	1	RECEPTACLE, TERMINAL HOUSING 3 P/N (MOLEX P/N 44441-2003)
20	3	CRIMP TERMINAL (MOLEX P/N 43375-0001) REQUIRES MOLEX CRIMP TOOL P/N 63811-0400
30	1	RING TERMINAL, #10 (3M P/N M0114-IDR)
40	XX FT	CABLE, 4 CONDUCTOR 14 AWG, SHIELDED (DELTA TAU P/N 023-14B004-0SH)
50	.50 FT	SHRINK TUBING (ALPHA P/N FT1221-1/4"BLK)

UNLESS OTHERWISE SPECIFIED ALL DIMENSIONS ARE IN INCHES TOLERANCES ARE: FRACTIONS DECIMALS ANGLES ±.005 ±.01 ±.015 ±.02	PROJECT REV. DATE MULTIPLE ASSY DATE DESIGNER: MILOK A. GOMEZ 11-22-02 CHECKER: DOUGLAS B. GIBSON	DELTA TAU DATA SYSTEMS, INC. CABLE ASSY, MOTOR 3 PH, APPLICABLE TO MODELS GXX012, GXX032 & GXX052 OTHERS SIZE DWG. NO. 200-603739 DASH NO. -XXX1- REV. B
MATERIAL: SEE B/N	APPROVED: [Signature]	SCALE: NONE
FINISH: SEE B/N	REF: CO-3739-1.DWG 1-03-05	SHEET 1 OF 1
DO NOT SCALE DRAWING		

REV.	DESCRIPTION	DATE	CHGD	APPROVED
1-	REVERSED PINS 1 & 3	10-21-04	N.G.	DOM. D.
2-	CHANGED FROM PIN # TO UWM	1-03-05	N.C.	BRAD L.

SEQ	QTY	DESCRIPTION
10	1	RECEPTACLE, TERMINAL HOUSING 3 PIN (MOLEX P/N 42816-0312)
20	3	CRIMP TERMINAL (MOLEX P/N 42815-0031)
30	1	REQUIRES MOLEX CRIMP TOOL P/N 63811-1500
40	XX FT	RING TERMINAL, #10 (3M P/N MJ14-IDR)
50	.50 FT	CABLE, 4 CONDUCTOR 14 AWG, SHIELDED (DELTA TAU P/N 023-14B004-03H)
		SHRINK TUBING (ALPHA P/N FIT221-1/4'BLK)

INSTALL CRIMP LOCK, SUPPLIED WITH ITEM 10

NOTES: UNLESS OTHERWISE SPECIFIED

1. PART NOS. ARE INTERPRETED AS FOLLOWS:
 THE FIRST 3 DIGITS OF THE SUFFIX DENOTES LENGTH AND THE LAST DIGIT OF THE SUFFIX DENOTES REVISION LEVEL. ALL LENGTHS ARE SPECIFIED IN INCHES.
 200-603738-0241 IS A REVISION 1 CABLE AND IS 24 FEET LONG.
2. CABLE/HARNESS ASSEMBLIES TO BE MADE WITH UL RECOGNIZED COMPONENTS AND LABELED UNDER WIRING HARNESS PROGRAM ZPFW2 AND MEET CSA STANDARD 22:2 ND10-M1982.
3. CABLE TO BE IDENTIFIED WITH PART NUMBER AND REVISION USING BLACK INDELIBLE INK PRINTED ON LABEL. LABEL TO BE PERMANENTLY ATTACHED TO CABLE.

TABULATION
-XXXX DESCRIPTION
-0101 10 FEET
-0201 20 FEET

REV.	DESCRIPTION	DATE	CHGD	APPROVED
1-	REVERSED PINS 1 & 3	10-21-04	N.G.	DOM. D.
2-	CHANGED FROM PIN # TO UWM	1-03-05	N.C.	BRAD L.

REVISIONS			
REV	DESCRIPTION	DATE	CHKD APPROVED
--	NEW DRAWING RELEASE	1-03-05	N.C. BRAD L.
-A	REVERSED U & W	2-09-05	N.C. BRAD L.

TABULATION	DESCRIPTION
-XXXX	10 FEET
-0E00	20 FEET

LENGTH XXX ± 3"

1.50" + / - .25

UNTERMINATED

U - WHT
V - RED
W - BLK
GND - GRN

INSTALL CRIMP LOCK,
SUPPLIED WITH ITEM 10

SEQ	QTY	DESCRIPTION
10	1	RECEPTACLE, TERMINAL HOUSING 4 PIN (MOLEX P/N 42816-0412)
20	4	CRIMP TERMINAL (MOLEX P/N 42815-0031) REQUIRES MOLEX CRIMP TOOL P/N 63811-1500
30	XX FT	CABLE, 4 CONDUCTOR 10 AWG, UNSHIELDED (AMXITER P/N 44-1004)

NOTES: UNLESS OTHERWISE SPECIFIED

- PART NOS. ARE INTERPRETED AS FOLLOWS:
THE FIRST 3 DIGITS OF THE SUFFIX DENOTES LENGTH AND THE LAST DIGIT OF THE SUFFIX DENOTES REVISION LEVEL. ALL LENGTHS ARE SPECIFIED IN INCHES.
200-603838-0241 IS A REVISION 1 CABLE AND IS 24 FEET LONG.
- CABLE/HARNESS ASSEMBLIES TO BE MADE WITH UL RECOGNIZED COMPONENTS AND LABELED UNDER WIRING HARNESS PROGRAM ZPFWR AND MEET CSA STANDARD 22.2 ND 0-01-982.
- CABLE TO BE IDENTIFIED WITH PART NUMBER AND REVISION USING BLACK INDELIBLE INK PRINTED ON LABEL. LABEL TO BE PERMANENTLY ATTACHED TO CABLE.

DELTA TAU DATA SYSTEMS, INC.	
P/N: GEO-DRIVES MULTIPLE ASSY DRAWING: IND. A. DOMEZ 1-03-05 DATE: 1-03-05 BY: IND. A. DOMEZ 1-03-05 CHECKED: SEE B/M APPROVAL: SEE B/M	CABLE ASSY, 3 PH + GND, MODELS GXX201 & GXX301 SIZE: 200-603838 DASH NO.: -YXX0 SCALE: NONE SHEET: 1 OF 1

REVISIONS			
REV.	DESCRIPTION	DATE	CHGD. APPROVED
1-	CHANGED FROM P/N # TO L#	1-03-05	N.G. BRAD L.

TABULATION	
-XXXX	DESCRIPTION
-0030	3 FEET

INSTALL CRIMP LOCK SUPPLIED WITH ITEM 10

NOTES: UNLESS OTHERWISE SPECIFIED

- PART NOS. ARE INTERPRETED AS FOLLOWS:
 THE FIRST 3 DIGITS OF THE SUFFIX DENOTES LENGTH AND THE LAST DIGIT OF THE SUFFIX DENOTES REVISION LEVEL. ALL LENGTHS ARE SPECIFIED IN INCHES.
 2C1-603738-0241 IS A REVISION 1 CABLE AND IS 24 FEET LONG.
- CABLE/HARNESS ASSEMBLIES TO BE MADE WITH UL RECOGNIZED COMPONENTS AND LABELED UNDER WIRING HARNESS PROGRAM ZPFW2 AND MEET CSA STANDARD 222 ND.0-H1982.
- CABLE TO BE IDENTIFIED WITH PART NUMBER AND REVISION USING BLACK INDELIBLE INK PRINTED ON LABEL. LABEL TO BE PERMANENTLY ATTACHED TO CABLE.

PARTS LIST		
SEQ	QTY	DESCRIPTION
10	1	RECEPTACLE, TERMINAL HOUSING 3 PIN (MOLEX P/N 42816-0312)
20	3	CRIMP TERMINAL (MOLEX P/N 42815-0031) REQUIRES MOLEX CRIMP TOOL P/N 63811-1500
30	XX FT.	WIRE, BLACK 12 AWG, 3 EQUAL LENGTHS (AMIXTER P/N 1015-12/65-0)

<p><small>UNLESS OTHERWISE SPECIFIED ALL DIMENSIONS ARE IN INCHES UNLESS OTHERWISE SPECIFIED</small></p> <p>PRECISION TERMINALS 441005 ±.0005 ±.001 ±.001 ±.002</p>	<p>PROJECT: GEO-DRIVES</p> <p>REV. DATE: MULTIPLE ASSY</p> <p>DESIGNER: MILOK A. GOMEZ 11-27-02</p> <p>DRAWN: SEE B/M</p> <p>FINISH: SEE B/M</p>	<p>DELTA TAU DATA SYSTEMS, INC.</p> <p>CABLE ASSY, AC INPUT 3 PH, APPLICABLE FOR ALL MODELS</p> <p>SIZE: Dwg. NO. 2C1-603738 DASH NO. -XXX1</p> <p>SCALE: NONE SHEET 1 OF 1</p>
<p>DO NOT SCALE DRAWING</p>		

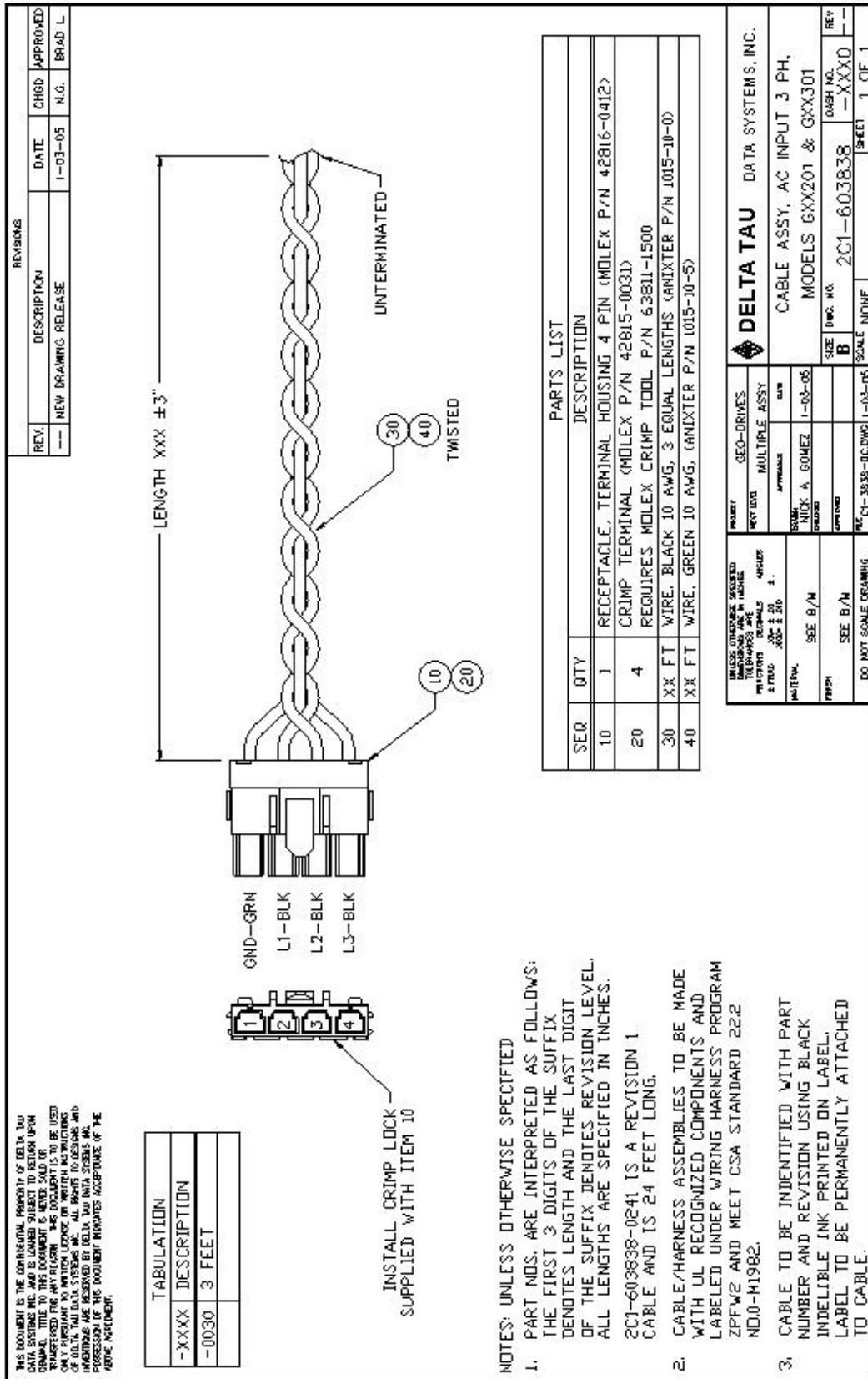

Regenerative Resistor: GAR78/48

Model	Description	1.5/4.5A	3/9A	5/10A	10/20A	15/30A	20/40A	30/60A
GAR78	300W 78 OHM regenerative resistor with Thermostat protection. Includes 18-inch wire cable. Single or Dual Axis.	✓	✓	✓				
GAR48	300W 48 OHM regenerative resistor with Thermostat protection. Includes 18-inch wire cable. Single or Dual Axis.				✓	✓		
GAR48-3	300W 48 OHM regenerative resistor with Thermostat protection. Includes 18-inch wire cable.						✓	✓

THIS DOCUMENT IS THE CONFIDENTIAL PROPERTY OF DELTA TAU DATA SYSTEMS, INC. AND IS LOANED SUBJECT TO RETURN UPON DEMAND. TRUE TO THIS DOCUMENT IS HEREBY GRANTED OR TRANSFERRED FOR ANY REASON. THIS DOCUMENT IS TO BE USED ONLY PURSUANT TO WRITTEN LICENSE OR WRITTEN INSTRUCTIONS OF DELTA TAU DATA SYSTEMS, INC. ALL RIGHTS TO PATENTS AND INVENTIONS ARE RESERVED BY DELTA TAU DATA SYSTEMS, INC. POSSESSION OF THIS DOCUMENT INDICATES ACCEPTANCE OF THE ABOVE AGREEMENT.

REVISIONS			
REV.	DESCRIPTION	DATE	CHGD. APPROVED
--	NEW DRAWING RELEASE	2-04-03	N.G. BILL K.

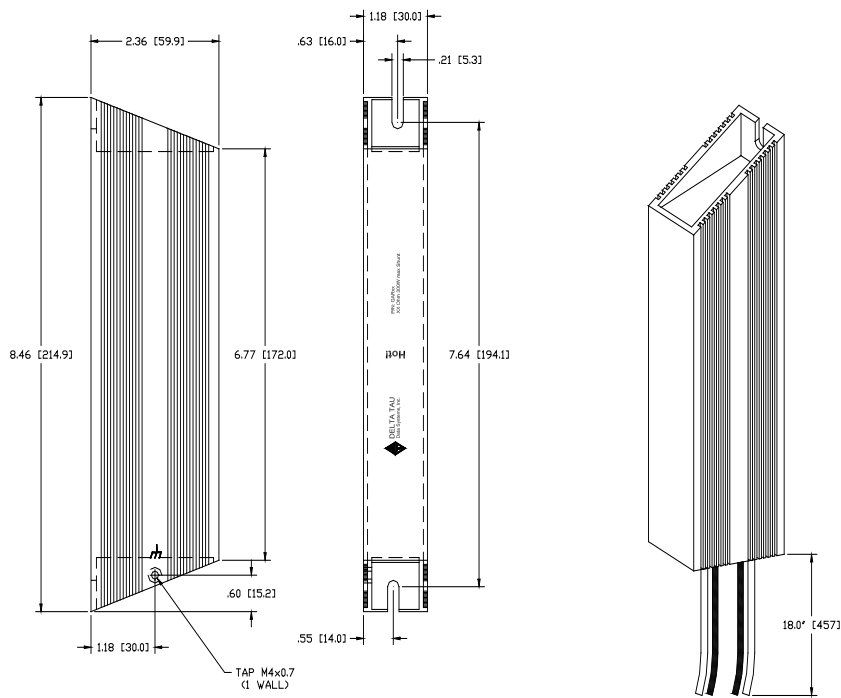

Specifications:
 Continuous Wattage: 300 Watts
 Hi Pot: 2500VAC 1 Second
 Thermostat:
 Normally Closed
 115VAC, 1 Amp
 Open at 227 +/- 11 degrees C.

Ohms:
 008-0GAR48 is 48 ohms
 008-0GAR78 is 78 Ohms

Leads:
 Resistor: 18 inch High Temp, 14 AWG Min, White
 Thermostat: 18 inch High Temp, 16 AWG Min, Black

Vendor Reference Numbers:
 008-0GAR48: SPR822-1
 008-0GAR78: SPR822-2
 IRV Series

NOTE:
 1. SILKSCREEN SIDES SHOWN PER ARTWORK.
 008-0GARxx-ART, USING BLACK EPDXY INK.

UNLESS OTHERWISE SPECIFIED TOLERANCES ARE: DIMENSIONS IN INCHES: FRACTIONS: DECIMALS: ANGLES: .010" & .015" .001" & .002" .010" & .015" .010" & .015"	PROJECT: GEO-BOOK AMP	DELTA TAU DATA SYSTEMS, INC.	
MATERIAL: NONE	REV. LEVEL: MULTIPLE ASSY	RESISTOR, SHUNT REGULATOR, 48 & 78 Ohm 300W MAX	
DATE: 02-04-03	APPROVED: NICK A. COMEZ	SIZE: C	DWG. NO.: 008-0GARXX
ISSUE: SEE NOTES	DATE: 02-04-03	SCALE: NONE	SHEET: 1 OF 1

Type of Cable for Encoder Wiring

Low capacitance shielded twisted pair cable is ideal for wiring differential encoders. The better the shield wires, the better the noise immunity to the external equipment wiring. Wiring practice for shielded cables is not an exact science. Different applications will present different sources of noise, and experimentation may be required to achieve the desired results. Therefore, the following recommendations are based upon some experiences that we at Delta Tau Data Systems have acquired.

If possible, the best cabling to use is a double-shielded twisted pair cable. Typically, there are four pairs used in a differential encoder's wiring. The picture below shows how the wiring may be implemented for a typical differential sinusoidal encoder using double shielded twisted pair cable.

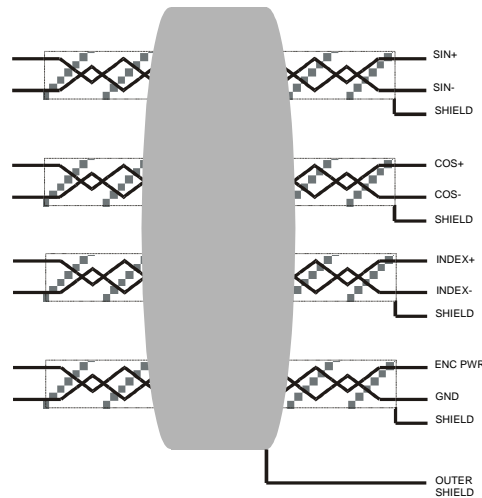

EXAMPLE OF DOUBLE SHIELDED
4 TWISTED PAIR CABLE

The shield wires should be tied to ground (Vcc return) at the interpolator end. It is acceptable to tie the shield wires together if there are not enough terminals available. Keep the exposed wire lengths as close as possible to the terminals on the interpolator.

Note:

It has been observed that there is an inconsistency in the shielding styles that are used by different encoder manufacturers.

Be sure to check pre-wired encoders to ensure that the shield wires are not connected at the encoder's side. Shield wires should be connected only on one side of the cable.

If the encoder has shield wires that are connected to the case ground of the encoder, ensure that the encoder and motor cases are sufficiently grounded. Do not connect the shield at the interpolator end.

If the encoder has pre-wired double shielded cable that has only the outer shield connected at the encoder, then connect only the inner shield wires to the interpolator. Be sure not to mix the shield interconnections.

One possible cable type for encoders is Belden 8164 or ALPHA 6318. This is a 4-pair individually shielded cable that has an overall shield. This double-shielded cable has a relatively low capacitance and is a 100Ω impedance cable.

Cables for single-ended encoders should be shielded for the best noise immunity. Single-ended encoder types cannot take advantage of the differential noise immunity that comes with twisted pair cables.

Note:

If noise is a problem in the application, careful attention must be given to the method of grounding that is used in the system. Amplifier and motor grounding can play a significant role in how noise is generated in a machine.

Noise may be reduced in a motor-based system by the use of inductors placed between the motor and the amplifier.

APPENDIX B

Schematics

X8 and X9 S.Encoder

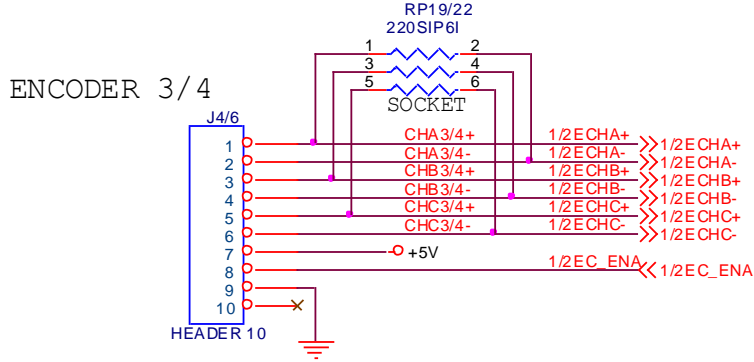

X3: General Purpose IO

Inputs

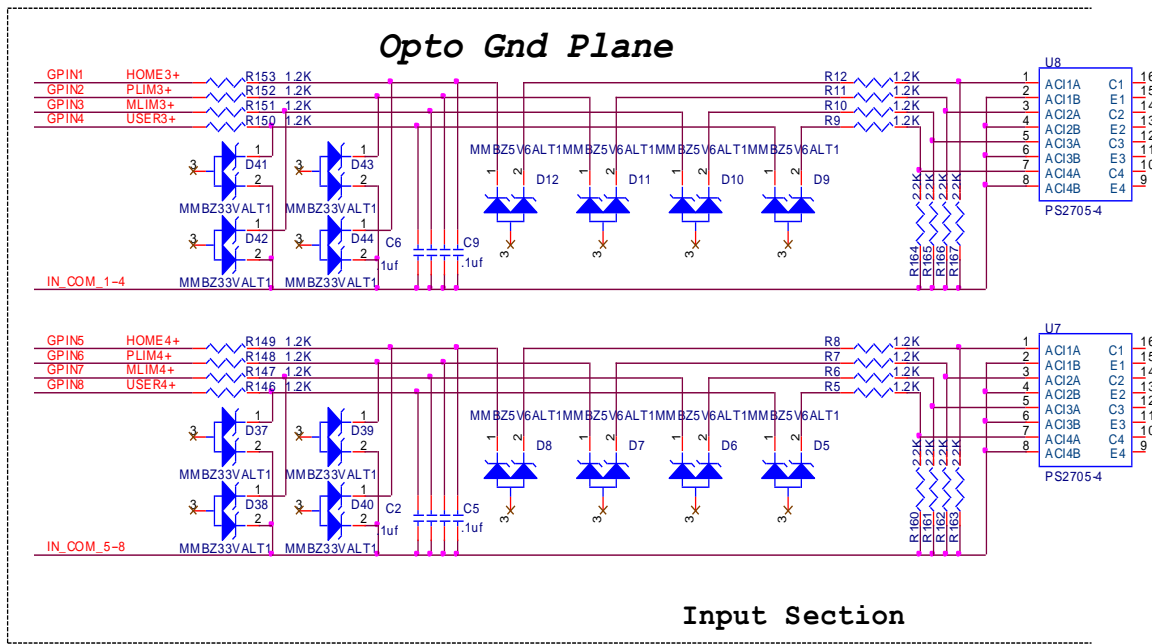

Outputs

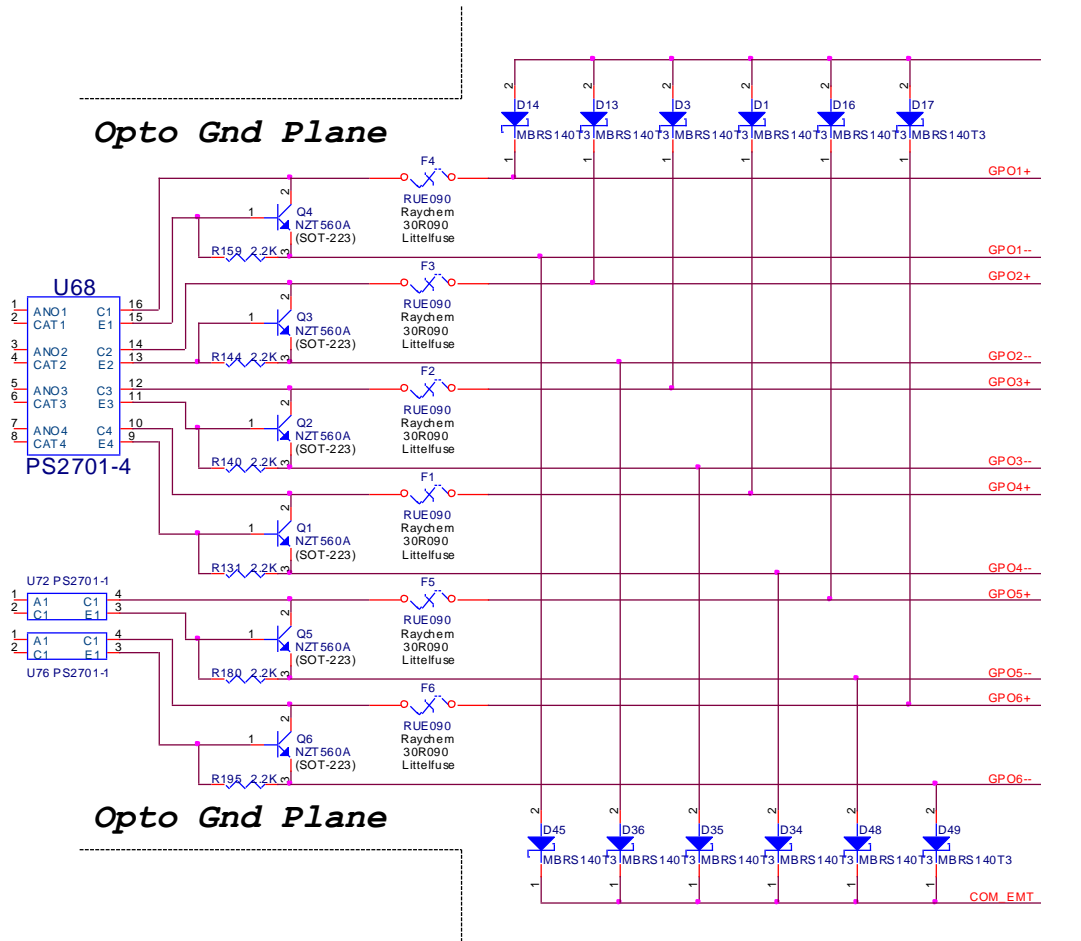

X10: Limits for Axis 1 and 2

Axis 1 (RP7 for 5V flags) and Axis 2 (RP8 for 5V flags)

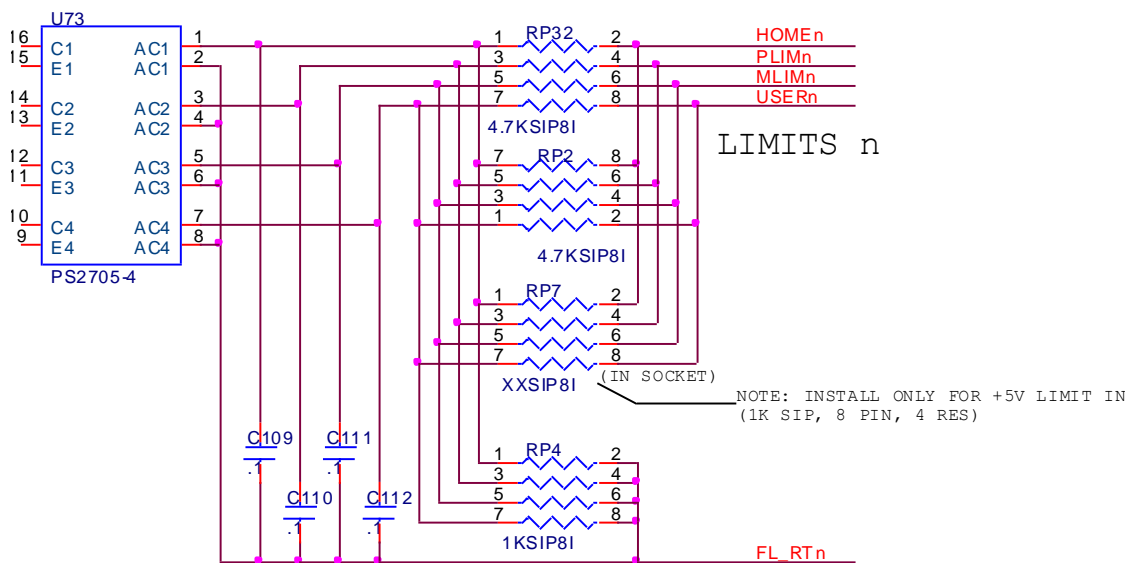

APPENDIX C

SUGGESTED M-VARIABLE DEFINITIONS

; This file contains suggested definitions for M-variables on the Geo PMAC Drive. It is similar to the file for the PMAC(2) family of boards, but there are significant differences in the input/output definitions, both for servo registers and general-purpose I/O. Note that these are only suggestions; the user is free to make whatever definitions are desired.

; Clear existing definitions

```
CLOSE ; Make sure no buffer is open on PMAC2
M0..1023->* ; All M-variables are now self-referenced
```

; JI/O Port M-variables

```
M1->X:$C010,16 ;X3 Pin1, Input 1
M2->X:$C010,17 ;X3 Pin2, Input 2
M3->X:$C010,18 ;X3 Pin3, Input 3
M4->X:$C010,19 ;X3 Pin4, Input 4
M5->X:$C018,16 ;X3 Pin5, Input 5
M6->X:$C018,17 ;X3 Pin6, Input 6
M7->X:$C018,18 ;X3 Pin7, Input 7
M8->X:$C018,19 ;X3 Pin8, Input 8
```

```
M9->Y:$FFC4,0 ; X3 Pin 13 or 14, Output1
```

```
M10->Y:$FFC4,1 ; X3 Pin 15 or 16, Output2
```

```
M11->Y:$FFC4,2 ; X3 Pin 17 or 18, Output3
```

```
M12->Y:$FFC4,3 ; X3 Pin 19 or 20, Output4
```

```
; For outputs 5 and 6 we use the same address with EQU3 and 4
; respectively
```

```
M311->X:$C015,11,1 ; EQU_3 compare flag latch control
```

```
M312->X:$C015,12,1 ; EQU_3 output write enable,
```

```
M13->X:$C015,12,1 ; X3 Pin 21 or 22, Output 5
```

```
M411->X:$C01D,11,1 ; EQU_4 compare flag latch control
```

```
M412->X:$C01D,12,1 ; EQU_4 output write enable
```

```
M14->X:$C01D,12,1 ; X3 Pin 23 or 24, Output 6
```

; User timer registers -- count down once per servo cycle

```
M70->Y:$0700,0,24,S ; 24-bit countdown user timer
```

```
M71->X:$0700,0,24,S ; 24-bit countdown user timer
```

```
M72->Y:$0701,0,24,S ; 24-bit countdown user timer
```

```
M73->X:$0701,0,24,S ; 24-bit countdown user timer
```

; Servo cycle counter (read only) -- counts up once per servo cycle

```
M100->X:$0000,0,24,S ; 24-bit servo cycle counter
```

; Gate Array Registers for Channel 1

```
M101->X:$C001,0,24,S ; ENC1 24-bit counter position
```

```
M102->Y:$C002,8,16,S ; OUT1A command value; DAC or PWM
```

```
M103->X:$C003,0,24,S ; ENC1 captured position
```

```
M104->Y:$C003,8,16,S ; OUT1B command value; DAC or PWM
```

```
M105->X:$0710,8,16,S ; ADC1A input image value
```

```
M106->Y:$0710,8,16,S ; ADC1B input image value
```

```
M107->Y:$C004,8,16,S ; OUT1C command value; PFM or PWM
```

```

M108->Y:$C007,0,24,S ; ENC1 compare A position
M109->X:$C007,0,24,S ; ENC1 compare B position
M110->X:$C006,0,24,S ; ENC1 compare auto increment value
M111->X:$C005,11 ; ENC1 compare initial state write enable
M112->X:$C005,12 ; ENC1 compare initial state
M114->X:$C005,14 ; AENA1 output status
M115->X:$C000,19 ; USER1 flag input status
M116->X:$C000,9 ; ENC1 compare output value
M117->X:$C000,11 ; ENC1 capture flag
M118->X:$C000,8 ; ENC1 count error flag
M119->X:$C000,14 ; CHC1 input status
M120->X:$C000,16 ; HMFL1 flag input status
M121->X:$C000,17 ; PLIM1 flag input status
M122->X:$C000,18 ; MLIM1 flag input status
M123->X:$C000,15 ; FAULT1 flag input status
M124->X:$C000,20 ; Channel 1 W flag input status
M125->X:$C000,21 ; Channel 1 V flag input status
M126->X:$C000,22 ; Channel 1 U flag input status
M127->X:$C000,23 ; Channel 1 T flag input status
M128->X:$C000,20,4 ; Channel 1 TUVW inputs as 4-bit value

; Motor #1 Status Bits
M130->Y:$0814,11,1 ; #1 Stopped-on-position-limit bit
M131->X:$003D,21,1 ; #1 Positive-end-limit-set bit
M132->X:$003D,22,1 ; #1 Negative-end-limit-set bit
M133->X:$003D,13,1 ; #1 Desired-velocity-zero bit
M135->X:$003D,15,1 ; #1 Dwell-in-progress bit
M137->X:$003D,17,1 ; #1 Running-program bit
M138->X:$003D,18,1 ; #1 Open-loop-mode bit
M139->Y:$0814,14,1 ; #1 Amplifier-enabled status bit
M140->Y:$0814,0,1 ; #1 In-position bit
M141->Y:$0814,1,1 ; #1 Warning-following error bit
M142->Y:$0814,2,1 ; #1 Fatal-following-error bit
M143->Y:$0814,3,1 ; #1 Amplifier-fault-error bit
M145->Y:$0814,10,1 ; #1 Home-complete bit

; Motor #1 Move Registers
M161->D:$0028 ; #1 Commanded position (1/[Ix08*32] cts)
M162->D:$002B ; #1 Actual position (1/[Ix08*32] cts)
M163->D:$080B ; #1 Target (end) position (1/[Ix08*32] cts)
M164->D:$0813 ; #1 Position bias (1/[Ix08*32] cts)
M165->L:$081F ; &1 X-axis target position (engineering units)
M166->X:$0033,0,24,S ; #1 Actual velocity (1/[Ix09*32] cts/cyc)
M167->D:$002D ; #1 Present master pos (1/[Ix07*32] cts)
M168->X:$0043,8,16,S ; #1 Filter Output (DAC bits)
M169->D:$004A ; #1 Compensation correction (1/[Ix08*32] cts)
M170->D:$0040 ; #1 Present phase position (including fraction)
M171->X:$0040,24,S ; #1 Present phase position (counts *Ix70)

```

M172->L:\$082B ; #1 Variable jog position/distance (cts)
M173->Y:\$0815, 24, S ; #1 Encoder home capture position (cts)
M174->Y:\$082A, 24, S ; #1 Averaged actual velocity (1/[Ix09*32] cts/cyc)

; Coordinate System &1 Status Bits

M180->X:\$0818, 0, 1 ; &1 Program-running bit
M181->Y:\$0817, 21, 1 ; &1 Circle-radius-error bit
M182->Y:\$0817, 22, 1 ; &1 Run-time-error bit
M184->X:\$0818, 0, 4 ; &1 Continuous motion request
M187->Y:\$0817, 17, 1 ; &1 In-position bit (AND of motors)
M188->Y:\$0817, 18, 1 ; &1 Warning-following-error bit (OR)
M189->Y:\$0817, 19, 1 ; &1 Fatal-following-error bit (OR)
M190->Y:\$0817, 20, 1 ; &1 Amp-fault-error bit (OR of motors)

; Motor #1 Axis Definition Registers

M191->L:\$0822 ; #1 X/U/A/B/C-Axis scale factor (cts/unit)
M192->L:\$0823 ; #1 Y/V-Axis scale factor (cts/unit)
M193->L:\$0824 ; #1 Z/W-Axis scale factor (cts/unit)
M194->L:\$0825 ; #1 Axis offset (cts)

; Coordinate System &1 Variables

M197->X:\$0806, 0, 24, S ; &1 Host commanded time base (I10 units)
M198->X:\$0808, 0, 24, S ; &1 Present time base (I10 units)

; Gate Array Registers for Channel 2

M201->X:\$C009, 0, 24, S ; ENC2 24-bit counter position
M202->Y:\$C00A, 8, 16, S ; OUT2A command value; DAC or PWM
M203->X:\$C00B, 0, 24, S ; ENC2 captured position
M204->Y:\$C00B, 8, 16, S ; OUT2B command value; DAC or PWM
M205->X:\$0711, 8, 16, S ; ADC2A input image value
M206->Y:\$0711, 8, 16, S ; ADC2B input image value
M207->Y:\$C00C, 8, 16, S ; OUT2C command value; PFM or PWM
M208->Y:\$C00F, 0, 24, S ; ENC2 compare A position
M209->X:\$C00F, 0, 24, S ; ENC2 compare B position
M210->X:\$C00E, 0, 24, S ; ENC2 compare auto increment value
M211->X:\$C00D, 11 ; ENC2 compare initial state write enable
M212->X:\$C00D, 12 ; ENC2 compare initial state
M214->X:\$C00D, 14 ; AENA2 output status
M215->X:\$C008, 19 ; USER2 flag input status
M216->X:\$C008, 9 ; ENC2 compare output value
M217->X:\$C008, 11 ; ENC2 capture flag
M218->X:\$C008, 8 ; ENC2 count error flag
M219->X:\$C008, 14 ; CHC2 input status
M220->X:\$C008, 16 ; HMFL2 flag input status
M221->X:\$C008, 17 ; PLIM2 flag input status
M222->X:\$C008, 18 ; MLIM2 flag input status
M223->X:\$C008, 15 ; FAULT2 flag input status
M224->X:\$C008, 20 ; Channel 2 W flag input status
M225->X:\$C008, 21 ; Channel 2 V flag input status

```

M226->X:$C008,22           ; Channel 2 U flag input status
M227->X:$C008,23           ; Channel 2 T flag input status
M228->X:$C008,20,4         ; Channel 2 TUVW inputs as 4-bit value

; Motor #2 Status Bits
M230->Y:$08D4,11,1         ; #2 Stopped-on-position-limit bit
M231->X:$0079,21,1         ; #2 Positive-end-limit-set bit
M232->X:$0079,22,1         ; #2 Negative-end-limit-set bit
M233->X:$0079,13,1         ; #2 Desired-velocity-zero bit
M235->X:$0079,15,1         ; #2 Dwell-in-progress bit
M237->X:$0079,17,1         ; #2 Running-program bit
M238->X:$0079,18,1         ; #2 Open-loop-mode bit
M239->Y:$08D4,14,1         ; #2 Amplifier-enabled status bit
M240->Y:$08D4,0,1          ; #2 In-position bit
M241->Y:$08D4,1,1          ; #2 Warning-following error bit
M242->Y:$08D4,2,1          ; #2 Fatal-following-error bit
M243->Y:$08D4,3,1          ; #2 Amplifier-fault-error bit
M245->Y:$08D4,10,1         ; #2 Home-complete bit

; Motor #2 Move Registers
M261->D:$0064               ; #2 Commanded position (1/[Ix08*32] cts)
M262->D:$0067               ; #2 Actual position (1/[Ix08*32] cts)
M263->D:$08CB               ; #2 Target (end) position (1/[Ix08*32] cts)
M264->D:$08D3               ; #2 Position bias (1/[Ix08*32] cts)
M265->L:$0820               ; &1 Y-axis target position (engineering units)
M266->X:$006F,0,24,S        ; #2 Actual velocity (1/[Ix09*32] cts/cyc)
M267->D:$0069               ; #2 Present master pos (1/[Ix07*32] cts)
M268->X:$007F,8,16,S        ; #2 Filter Output (DAC bits)
M269->D:$0086               ; #2 Compensation correction (1/[Ix08*32] cts)
M270->D:$007C               ; #2 Present phase position (including fraction)
M271->X:$007C,24,S          ; #2 Present phase position (counts *Ix70)
M272->L:$08EB               ; #2 Variable jog position/distance (cts)
M273->Y:$08D5,24,S          ; #2 Encoder home capture position (cts)
M274->Y:$08EA,24,S          ; #2 Averaged actual velocity (1/[Ix09*32] cts/cyc)

; Coordinate System &2 Status Bits
M280->X:$08D8,0,1           ; &2 Program-running bit
M281->Y:$08D7,21,1           ; &2 Circle-radius-error bit
M282->Y:$08D7,22,1           ; &2 Run-time-error bit
M284->X:$08D8,0,4           ; &2 Continuous motion request
M287->Y:$08D7,17,1           ; &2 In-position bit (AND of motors)
M288->Y:$08D7,18,1           ; &2 Warning-following-error bit (OR)
M289->Y:$08D7,19,1           ; &2 Fatal-following-error bit (OR)
M290->Y:$08D7,20,1           ; &2 Amp-fault-error bit (OR of motors)

; Motor #2 Axis Definition Registers
M291->L:$08E2               ; #2 X/U/A/B/C-Axis scale factor (cts/unit)
M292->L:$08E3               ; #2 Y/V-Axis scale factor (cts/unit)
M293->L:$08E4               ; #2 Z/W-Axis scale factor (cts/unit)

```



```

M294->L:$08E5 ; #2 Axis offset (cts)

; Coordinate System &2 Variables
M297->X:$08C6,0,24,S ; &2 Host commanded time base (I10 units)
M298->X:$08C8,0,24,S ; &2 Present time base (I10 units)
; Coordinate System &3 Status Bits
M380->X:$0998,0,1 ; &3 Program-running bit
M381->Y:$0997,21,1 ; &3 Circle-radius-error bit
M382->Y:$0997,22,1 ; &3 Run-time-error bit
M384->X:$0998,0,4 ; &3 Continuous motion request
M387->Y:$0997,17,1 ; &3 In-position bit (AND of motors)
M388->Y:$0997,18,1 ; &3 Warning-following-error bit (OR)
M389->Y:$0997,19,1 ; &3 Fatal-following-error bit (OR)
M390->Y:$0997,20,1 ; &3 Amp-fault-error bit (OR of motors)

; Coordinate System &3 Variables
M397->X:$0986,0,24,S ; &3 Host commanded time base (I10 units)
M398->X:$0988,0,24,S ; &3 Present time base (I10 units)

; Coordinate System &4 Status Bits
M480->X:$0A58,0,1 ; &4 Program-running bit
M481->Y:$0A57,21,1 ; &4 Circle-radius-error bit
M482->Y:$0A57,22,1 ; &4 Run-time-error bit
M484->X:$0A58,0,4 ; &4 Continuous motion request
M487->Y:$0A57,17,1 ; &4 In-position bit (AND of motors)
M488->Y:$0A57,18,1 ; &4 Warning-following-error bit (OR)
M489->Y:$0A57,19,1 ; &4 Fatal-following-error bit (OR)
M490->Y:$0A57,20,1 ; &4 Amp-fault-error bit (OR of motors)

; Coordinate System &4 Variables
M497->X:$0A46,0,24,S ; &4 Host commanded time base (I10 units)
M498->X:$0A48,0,24,S ; &4 Present time base (I10 units)

; Coordinate System &5 Status Bits
M580->X:$0B18,0,1 ; &5 Program-running bit
M581->Y:$0B17,21,1 ; &5 Circle-radius-error bit
M582->Y:$0B17,22,1 ; &5 Run-time-error bit
M584->X:$0B18,0,4 ; &5 Continuous motion request
M587->Y:$0B17,17,1 ; &5 In-position bit (AND of motors)
M588->Y:$0B17,18,1 ; &5 Warning-following-error bit (OR)
M589->Y:$0B17,19,1 ; &5 Fatal-following-error bit (OR)
M590->Y:$0B17,20,1 ; &5 Amp-fault-error bit (OR of motors)

; Coordinate System &5 Variables
M597->X:$0B06,0,24,S ; &5 Host commanded time base (I10 units)
M598->X:$0B08,0,24,S ; &5 Present time base (I10 units)

; Coordinate System &6 Status Bits
M680->X:$0BD8,0,1 ; &6 Program-running bit
M681->Y:$0BD7,21,1 ; &6 Circle-radius-error bit
M682->Y:$0BD7,22,1 ; &6 Run-time-error bit
M684->X:$0BD8,0,4 ; &6 Continuous motion request

```

M687->Y:\$0BD7,17,1 ; &6 In-position bit (AND of motors)
M688->Y:\$0BD7,18,1 ; &6 Warning-following-error bit (OR)
M689->Y:\$0BD7,19,1 ; &6 Fatal-following-error bit (OR)
M690->Y:\$0BD7,20,1 ; &6 Amp-fault-error bit (OR of motors)

; Coordinate System &6 Variables
M697->X:\$0BC6,0,24,S ; &6 Host commanded time base (I10 units)
M698->X:\$0BC8,0,24,S ; &6 Present time base (I10 units)

; Coordinate System &7 Status Bits
M780->X:\$0C98,0,1 ; &7 Program-running bit
M781->Y:\$0C97,21,1 ; &7 Circle-radius-error bit
M782->Y:\$0C97,22,1 ; &7 Run-time-error bit
M784->X:\$0C98,0,4 ; &7 Continuous motion request
M787->Y:\$0C97,17,1 ; &7 In-position bit (AND of motors)
M788->Y:\$0C97,18,1 ; &7 Warning-following-error bit (OR)
M789->Y:\$0C97,19,1 ; &7 Fatal-following-error bit (OR)
M790->Y:\$0C97,20,1 ; &7 Amp-fault-error bit (OR of motors)

; Coordinate System &7 Variables
M797->X:\$0C86,0,24,S ; &7 Host commanded time base (I10 units)
M798->X:\$0C88,0,24,S ; &7 Present time base (I10 units)

; Coordinate System &8 Status Bits
M880->X:\$0D58,0,1 ; &8 Program-running bit
M881->Y:\$0D57,21,1 ; &8 Circle-radius-error bit
M882->Y:\$0D57,22,1 ; &8 Run-time-error bit
M884->X:\$0D58,0,4 ; &8 Continuous motion request
M887->Y:\$0D57,17,1 ; &8 In-position bit (AND of motors)
M888->Y:\$0D57,18,1 ; &8 Warning-following-error bit (OR)
M889->Y:\$0D57,19,1 ; &8 Fatal-following-error bit (OR)
M890->Y:\$0D57,20,1 ; &8 Amp-fault-error bit (OR of motors)

; Coordinate System &8 Variables
M897->X:\$0D46,0,24,S ; &8 Host commanded time base (I10 units)
M898->X:\$0D48,0,24,S ; &8 Present time base (I10 units)

; Analog Input Port M-Variables
M1000->Y:\$FF58,8,16,s ; ANAI00 image register; from X7
M1001->Y:\$FF78,8,16,s ; ANAI01 image register; from X7

; where {f} should be a U if the channel is read as an unsigned quantity,
; or an S if the channel is read as a signed quantity.

MEMORY AND I/O MAP ADDENDUM

The following addresses are unique to the Geo PMAC configuration of the PMAC2 controller family and may not appear in the general PMAC/PMAC2 Software Reference Manual.

Y:\$FF00	Channel 1 Resolver/Sine Encoder Sine ADC
Y:\$FF01	Channel 1 Resolver/Sine Encoder Cosine ADC (Note: Must be read immediate after Sine ADC)
Y:\$FF20	Channel 2 Resolver/Sine Encoder Sine ADC
Y:\$FF21	Channel 2 Resolver/Sine Encoder Cosine ADC (Note: Must be read immediate after Sine ADC)
Y:\$FF50	Resolver/SSI-Encoder Control Word (I1010 – I1012, I1015 – I1017)
Y:\$FF54	Channel 1 SSI Encoder Position
Y:\$FF58	Channel 1 16-Bit ADC
Y:\$FF70	SSI Control Word 2 (I1018 – I1019)
Y:\$FF74	Channel 2 SSI Encoder Position
Y:\$FF78	Channel 2 16-Bit ADC