

*Échelon™*

ICE MAKERS  
COMBO™ MODELS  
REFRIGERATORS

U  
S  
E  
R  
M  
A  
N  
U  
A  
L



**U-LINE**  
CORPORATION

## U-LINE CORPORATION LIMITED WARRANTY

U-Line Corporation warrants each U-Line product to be free from defects in materials and workmanship for a period of one year from the date of purchase; and warrants the sealed system (consisting of the compressor, the condenser, the evaporator, the hot gas bypass valve, the dryer and the connecting tubing) in each U-Line product to be free from defects in materials and workmanship for a period of five years from the date of purchase. During the initial one-year warranty period for all U-Line products U-Line shall: (1) at U-Line's option, repair any product or replace any part of a product that breaches this warranty; and (2) for all Marine, RV and Domestic U-Line products sold and serviced in the United States (including Alaska and Hawaii) and Canada, U-Line shall cover the labor costs incurred in connection with the replacement of any defective part. During years two through five of the warranty period for the sealed system, U-Line shall: (1) repair or replace any part of the sealed system that breaches this warranty; and (2) for all Marine, RV and Domestic U-Line products sold and serviced in the United States (including Alaska and Hawaii) and Canada, U-Line shall cover the labor costs incurred in connection with the replacement of any defective part of the sealed system. All other charges, including transportation charges for replacements under this warranty and labor costs not specifically covered by this warranty, shall be borne by you. This warranty is extended only to the original purchaser of the U-Line product. The Registration Card included with the product should be promptly completed by you and mailed back to U-Line.

The following are excluded from this limited warranty: installation charges; damages caused by disasters or acts of God, such as fire, floods, wind and lightning; damages incurred or resulting from shipping, improper installation, unauthorized modification, or misuse/abuse of the product; customer education calls; food loss/spoilage; door and water level adjustments (except during the first 90 days from the date of purchase); defrosting the product; adjusting the controls; door reversal; or cleaning the condenser.

If a product defect is discovered during the applicable warranty period, you must promptly notify either the dealer from whom you purchased the product or U-Line at P.O. Box 23220, Milwaukee, Wisconsin 53223 or at 414-354-0300. In no event shall such notification be received later than 30 days after the expiration of the applicable warranty period. U-Line may require that defective parts be returned, at your expense, to U-Line's factory in Milwaukee, Wisconsin, for inspection. Any action by you for breach of warranty must be commenced within one year after the expiration of the applicable warranty period.

**This limited warranty is in lieu of any other warranty, express or implied, including, but not limited to any implied warranty of merchantability or fitness for a particular purpose; provided however, that to the extent required by law, implied warranties are included but do not extend beyond the duration of the express warranty first set forth above. U-Line's sole liability and your exclusive remedy under this warranty is set forth in the initial paragraph above. U-Line shall have no liability whatsoever for any incidental, consequential or special damages arising from the sale, use or installation of the product or from any other cause whatsoever, whether based on warranty (express or implied) or otherwise based on contract, tort or any other theory of liability.**

Some states do not allow limitations on how long an implied warranty lasts or the exclusion or limitation of incidental or consequential damages, so the above limitations may not apply to you. This warranty gives you specific legal rights, and you may also have other rights which vary from state to state.

## INTRODUCTION

Congratulations on your purchase of U-Line ice making or refrigeration products. A pioneer in the field for nearly 40 years, U-Line is the world's number one manufacturer of built-in, under-counter ice making and specialty refrigeration products. U-Line dedicates 100% of its research and development to these products. The result: U-Line technology leads the market with innovation, design, depth of product line and performance.

U-Line also backs customers with a strong dealer network. U-Line's commitment to quality even extends to environmentally safe packaging. U-Line products are making life more convenient in homes, businesses, and hotels around the world.

### IMPORTANT

**PLEASE READ** all instructions completely before attempting to install or operate the unit. All models of Ice Makers and Combos require a connection to the water supply. Improper hook-up can result in substantial property damage! If you are unsure of your ability to safely connect the water supply to the unit, consult a licensed plumber for assistance.

Once you have your unit installed, we suggest you keep this manual in a safe place for future reference. Should any problems occur, refer to the **TROUBLESHOOTING** section of this manual. This information will help you quickly identify a problem and get it remedied. In the event you require assistance, please contact the dealer where you purchased your unit.

### PLEASE RECORD YOUR MODEL'S INFORMATION

Whenever you call to request information or service, you will need to know your model number and serial number. You can find this information on the serial plate located on the inside wall of your unit and on the warranty registration card.

### WARRANTY REGISTRATION CARD

The package containing this manual also includes your warranty registration information. Warranty coverage begins at the time your unit was purchased.

### NOTE

Complete and mail the Warranty Registration Card as soon as possible to validate the registration date.

# User's Manual

---

---

If you do not return your Warranty Registration Card, U-Line will use the date of sale to the U-Line distributor as the first date of warranty for your unit. Please also record the purchase date of your U-Line unit and your dealer's name, address and telephone number.

Model Number: \_\_\_\_\_  
Serial Number: \_\_\_\_\_  
Purchase Date: \_\_\_\_\_  
Dealer Name: \_\_\_\_\_  
Dealer Address: \_\_\_\_\_  
Dealer Telephone: \_\_\_\_\_

Keep this manual and the sales receipt together in a safe place for further reference.

## TABLE OF CONTENTS

INTRODUCTION.....	1
SAFETY PRECAUTIONS .....	3
INSTALLATION .....	5
CONNECTING THE WATER SUPPLY .....	7
LEVELING THE UNIT .....	9
REVERSING THE DOOR .....	9
CUSTOM DOOR PANELS .....	12
BUILT-IN INSTALLATION.....	14
INITIAL START-UP.....	14
NORMAL OPERATION .....	16
ADJUSTING THE TEMPERATURE CONTROL.....	17
OUTDOOR & MARINE USE .....	18
ADJUSTING ICE CUBE SIZE .....	18
MAINTENANCE.....	19
DEFROSTING .....	24
STORAGE .....	25
TROUBLESHOOTING .....	26
IF SERVICE IS REQUIRED .....	28

---

---

## SAFETY PRECAUTIONS

Do not attempt to install or operate your unit until you have read the safety precautions in this manual. Safety items throughout this manual are labeled with a Danger, Warning or Caution based on the risk type.

### DEFINITIONS



Danger means that failure to follow this safety statement may result in severe personal injury or death.



Warning means that failure to follow this safety statement may result in extensive product damage, serious personal injury, or death.

### CAUTION

Caution means that failure to follow this safety statement may result in minor or moderate personal injury, property or equipment damage.

# User's Manual

---

---

## GENERAL PRECAUTIONS



### **DANGER**



**RISK OF CHILD ENTRAPMENT.** Before you throw away your old refrigerator or freezer, take off the doors and leave shelves in place so that children may not easily climb inside.



### **WARNING**

- Never attempt to repair or perform maintenance on the unit until the electricity has been disconnected.
- Altering, cutting of power cord, removal of power cord, removal of power plug, or direct wiring can cause serious injury, fire and/or loss of property and/or life and will void the warranty.

### **CAUTION**

- Do not lift unit by door handle.
- Never use an ice pick or other sharp instrument to help speed up defrosting. These instruments can puncture the inner lining or damage cooling unit.
- Failure to clean the condenser every three months can cause the unit to malfunction. This could void the warranty.
- Never install the unit behind closed doors. Be sure front grille is free of obstruction. Obstructing free air flow can cause the unit to malfunction, and may void the warranty.

### **CAUTION**

- **DO NOT** use any type of heater to defrost. Using a heater to speed up defrosting can cause personal injury and damage to the inner lining.
- Use only genuine U-Line replacement parts. Imitation parts can reduce ice rate, cause water to overflow from ice maker mold, damage the unit, and may void the warranty.

# INSTALLATION

## SITE PREPARATION

1. Position the unit on a flat, level surface, capable of supporting the entire weight of the unit. Remember the unit will be significantly heavier once it is fully loaded.
2. This unit requires grounded and polarized 115 VAC, 60Hz, 15A circuit (normal household current).



### ELECTROCUTION HAZARD!



Electrical Grounding Required. This appliance is equipped with a three prong (grounding) polarized plug for your protection against possible shock hazards.

- NEVER remove the round grounding prong from the plug.
- NEVER use a two-prong grounding adapter.
- NEVER use an extension cord to connect power to the unit.

Where a two-prong wall receptacle is encountered or a longer power cord is required, contact a qualified electrician to have it replaced in accordance with applicable electrical codes.

### NOTE

All U-Line units (except Stainless Steel models) have a zero clearance for the door to open (see Figure 1). See **BUILT-IN INSTALLATION** for additional clearance requirements. Stainless steel models require a minimum of 2-1/2" door handle clearance when installed against a wall.

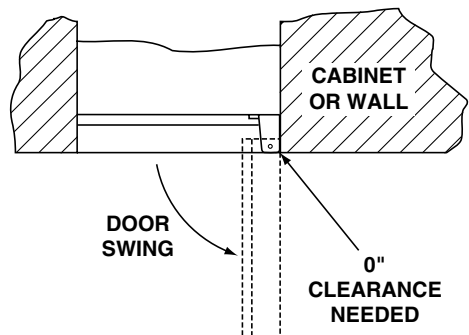

UL124A

Figure 1

# User's Manual

---

---

3. If installing an Ice Maker model, install and connect the water supply line. See **CONNECTING THE WATER SUPPLY** for installation requirements.
4. Position the unit to allow free air flow through the front grille (see Figure 2).

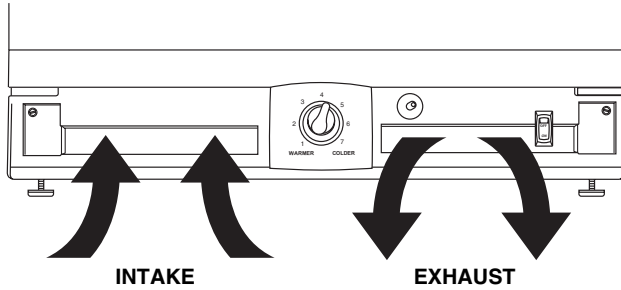

UL307

**Figure 2**

5. Wipe out inside of unit and ice bucket with a damp cloth.



## CONNECTING THE WATER SUPPLY

On Ice Maker models BI 2015 and Combo 2075FF, install a 1/4 inch outside diameter copper water line (not supplied with unit) from the nearest COLD water pipe. When connecting the water supply, follow these guidelines:

- Review the local plumbing codes before you install the unit.
  - In most instances, the cold water supply will come from the basement through a hole in the floor.
  - The water pressure should be between 15 and 150 psi.
  - Install a shut-off valve in the 1/4 inch outside diameter supply line.
  - Connect sufficient tubing to the unit to allow the unit to be moved for cleaning and servicing. However, make certain that the tubing is not pinched or damaged during installation.
  - U-Line recommends the use of copper tubing for installation.
1. Locate the compression fitting and ferrule packed in the unit. Slide the compression fitting and ferrule over the 1/4 inch outside diameter water supply line. **Do not use thread sealing compound or tape.** Using two wrenches, tighten the compression fitting on the supply line (see Figure 3).
  2. Carefully bend the water supply line into position and connect the line to the solenoid valve (see Figure 4). Avoid kinking the water supply line.

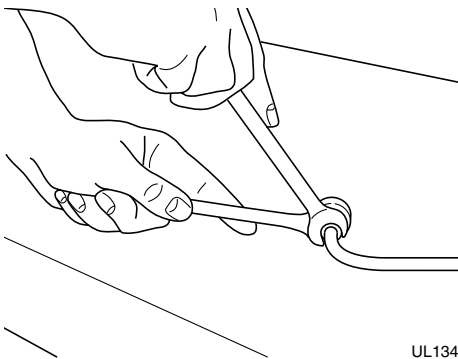

UL134

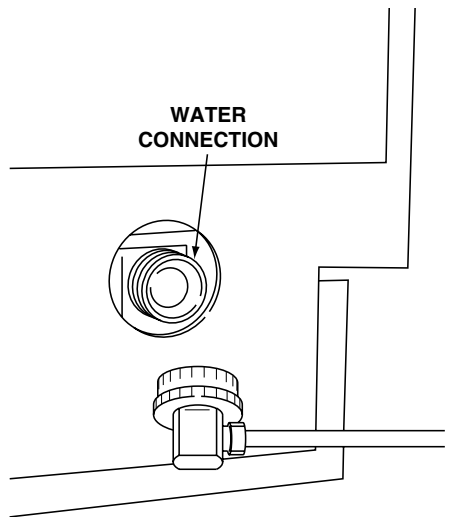

UL103

**Figure 3**

# User's Manual

3. For recessed installations, allow extra water supply line length to provide slack for easy removal from the recessed area (see Figure 5). This will also safeguard against kinking the line.

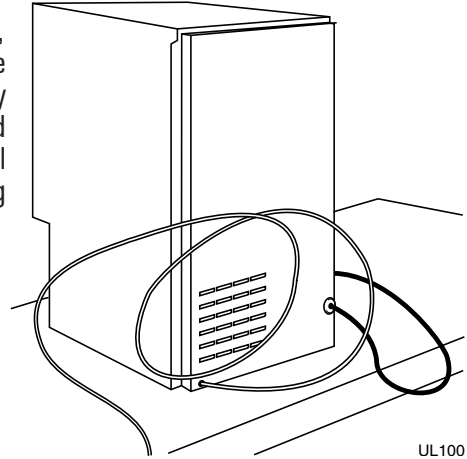

Figure 5

## CAUTION

If you are not intending to use the ice maker and do not connect the water supply (or turn the supply valve off), it is imperative to raise the bin arm of the ice maker (see Figure 6). Failure to raise the bin arm may result in damage to the water valve.

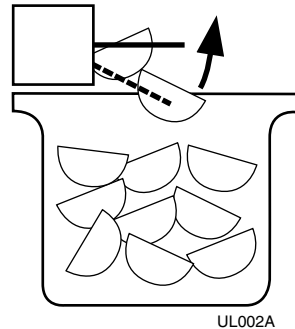

Figure 6

## NOTE

After completing the installation, turn on the water and recheck water connection for leaks. Apply additional tightening if needed. Do not use thread sealing compound or tape.

4. Plug in the power cord.
5. Gently push the unit into position. If desired the unit may be recessed into cabinet or wall.

## LEVELING THE UNIT

It is important that the unit, primarily the Ice Maker models, are level. All Échelon™ Series units are equipped with adjustable feet for leveling and height adjustment (see Figures 7 & 7A).

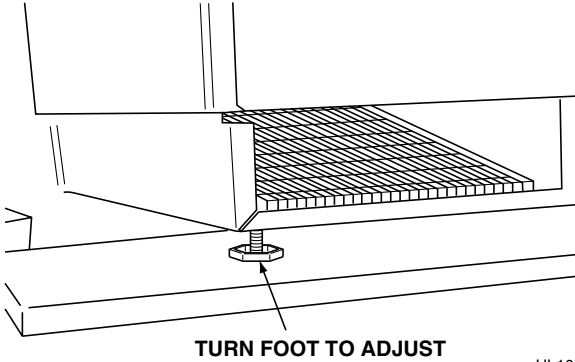

UL105

Figure 7

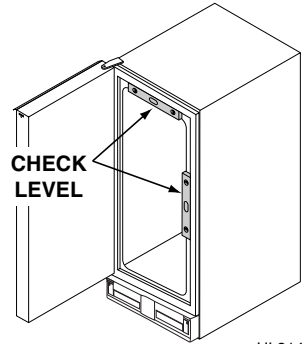

UL314

Figure 7A

## REVERSING THE DOOR

All U-Line units (except Stainless Steel models which must be ordered left or right hand opening) are field reversible for left or right hand opening. The door opening is easily reversed by moving the hinge hardware to the opposite side (see Figure 8).

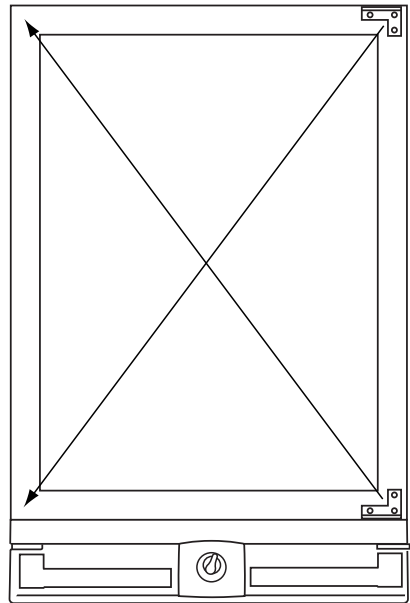

UL318

Figure 8

# User's Manual

To reverse the door:

1. Remove top hinge screw pin (7/64" Allen wrench) from cabinet (see Figure 9). Remove door by tilting forward and lifting off bottom hinge pin.

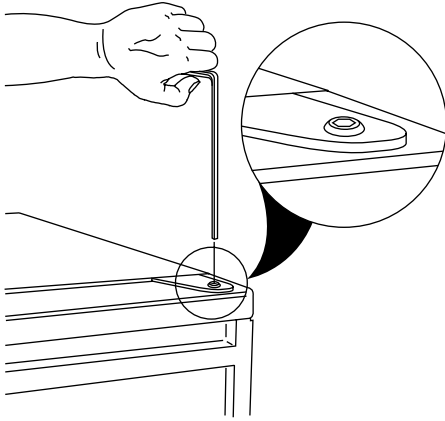

UL310

Figure 9

2. Remove plastic screw plugs (3 each, top and bottom) from new hinge location. Do not discard (see Figure 10).

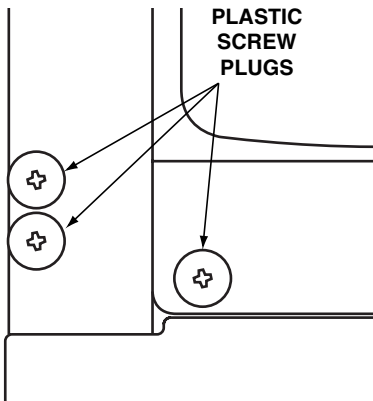

UL308

Figure 10

3. Remove top hinge (3 screws), reinstall hinge screw pin, and remount on opposite side BOTTOM (see Figure 11).

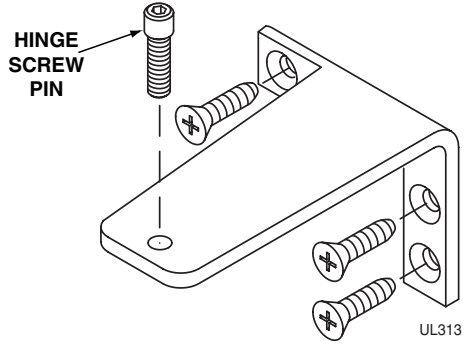

Figure 11

4. Remove the two door closer plastic inserts from the existing bottom hinge and install as shown on the new bottom hinge (see Figure 12).

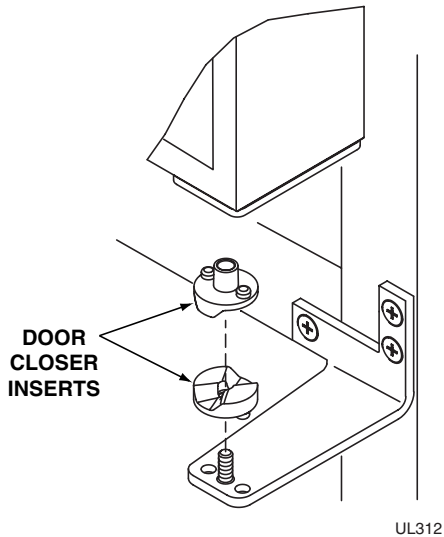
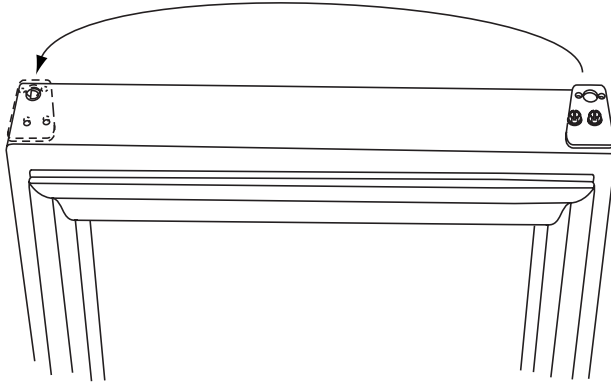

Figure 12

5. Remove existing bottom hinge (3 screws) and remount on opposite side TOP. Remove top hinge screw pin.
6. With bottom of door facing up, remove pivot plate (2 screws), flip over, and remount on opposite side of door (see Figure 13).



UL319

**Figure 13**

7. Holding door upright with top of door tilted forward, place hole of door pivot plate on bottom hinge screw pin (see Figure 14).
8. Tilt top of door into position in top hinge and install top hinge screw pin.
9. Install plastic screw plugs removed in Step 2 in existing hinge holes (3 each, top and bottom).

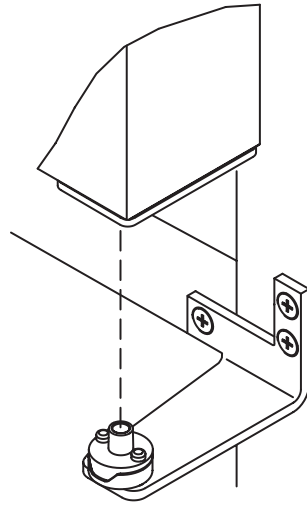

UL312A

**Figure 14**

# User's Manual

## CUSTOM DOOR PANELS

Two types of custom door panels can be installed on your U-Line unit to harmonize with or accent the surrounding decor.

### FULL OVERLAY DOOR PANEL

A full overlay door panel completely covers the door frame and handle to give a built-in appearance. See your U-Line dealer for the optional Full Overlay Door Panel Kit which contains the Panel Preparation Document for building and installing a full overlay panel. See Table 1 for full overlay door panel dimensions.

Table 1. Full Overlay Panel Dimensions

Model	A	B
2015 Series	29-7/8"	14-3/4"
2075 Series	29-7/8"	23-3/4"

### CUSTOM INSERT DOOR PANEL

A custom door panel can be inserted into the door frame to better match the surrounding decor. Custom door panels can be flat or raised, as long as the maximum panel thickness where inserted into the door reveal (channel) is 1/4" thick. For raised panels, the depth of the reveal is 1/4" on all four sides. See Table 2 for custom door panel insert dimensions.

Table 2. Custom Insert Door Panel Dimensions

Model	A	B
2015 Series	28-5/32"	14-1/32"
2075 Series	28-5/32"	23-1/32"

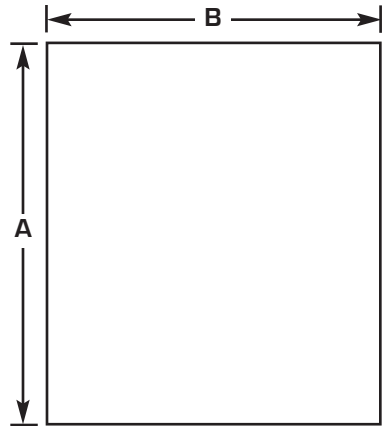

## IMPORTANT

Door panel insert must not weigh more than 20 lbs.

Install the insert as follows:



## WARNING

Insert edges may be **SHARP!**  
Use care when installing.

1. Remove top hinge screw pin (7/64" Allen wrench, see Figure 15). Remove door by tilting forward and lifting off bottom hinge pin.
2. Remove two outside screws holding door handle. Slightly separate door handle from door (see Figure 16).
3. Pull door gasket out of groove (top edge of door only). Start in the middle and pull outward, moving toward the edge (see Figure 17). This may take some force. Do not remove the three screws behind the gasket.
4. Pull handle up and off.

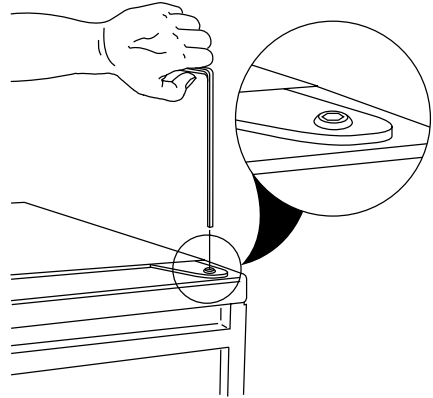

UL310

Figure 15

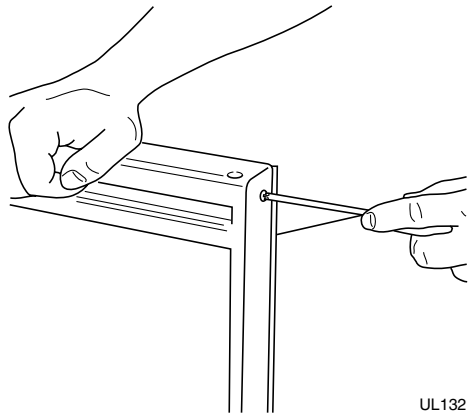

UL132

Figure 16

### NOTE

Use care not to bend light switch bracket (where installed), located on door bottom when installing door insert. Do not set door on bottom edge when pushing insert into place.

5. Slide custom door panel insert into 1/4 inch channel in door front.

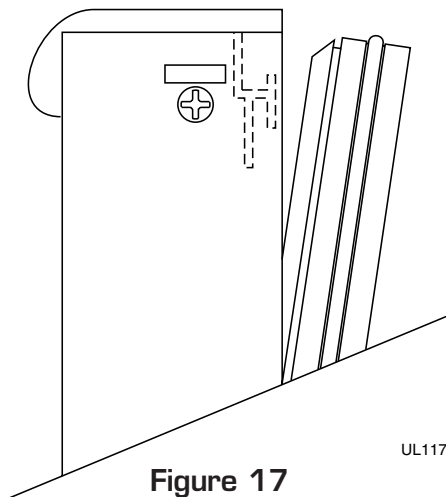

UL117

Figure 17

# User's Manual

6. Holding door gasket out of the way, replace handle on door making sure it is seated properly on insert and that screw holes line up.
7. Install two small screws removed in step 2.
8. Starting at the corners and working inward, push door gasket into place on door.
9. Place door on bottom hinge pin and install upper hinge screw.

## BUILT-IN INSTALLATION

Your U-Line product has been designed for either free-standing or built-in installation. When built-in, your U-Line product does not require additional air space for top, sides, or rear. However, the front grille must NOT be obstructed.

### NOTE

To ease unit installation and removal, it is recommended that the cabinet rough opening dimensions be increased by at least 1/4" over the dimensions given for your unit.

### Unit Dimensions

Model	Width	Height	Depth*
2015 Series	14-15/16"	34-1/8"	24"
2075 Series	23-15/16"	34-1/8"	24"

\* For full overlay door panels, add 3/4".

## INITIAL START-UP

Once installation is complete, the unit is ready for initial start-up and operation.

### CONTROL SETTINGS-COMBO/REFRIGERATOR

Models 2015R, 2075R and 2075RF are turned ON with the control knob located on the grille. Turn the knob clockwise for ON, counterclockwise for OFF. Models 2015R, 2075R and 2075RF turn OFF when the temperature control is turned counterclockwise all the way toward warmer until it stops (until "click" is heard).

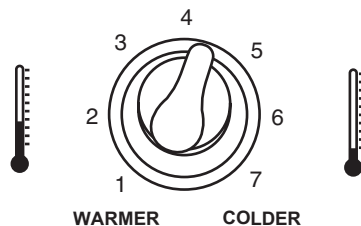

Figure 18

UL315



## CONTROL SETTINGS - COMBO/ICE MAKER

Models BI 2015 and 2075FF are turned ON with the ON/OFF switch recessed in the front grille (see Figure 19). In these units, the control dial is used only for temperature control.

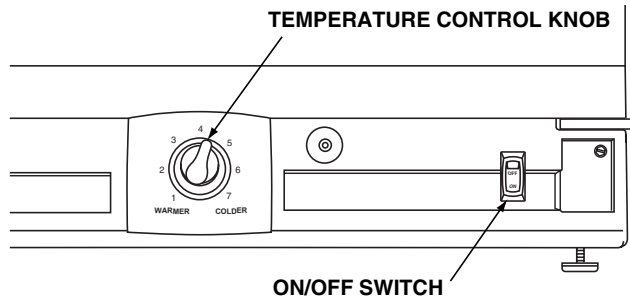

UL316B

Figure 19

1. Plug the appliance cord into a 115V polarized and grounded electrical outlet.
2. All units are shipped in the ON position.
3. Open the water supply valve in the main water source. As soon as the ice maker mold reaches the proper temperature, the ice maker mechanism will fill the mold with water. The first cubes may be small because of air in the water line. Subsequent cubes will be of standard size. Allow 2 hours for Frostfree models.

## IMPORTANT

It is possible that dirt or scale will dislodge in the water line. Always throw away all ice cubes made during the first two to three hours of operation.

## NORMAL OPERATION

On units with refrigerator sections, the unit has been designed to achieve a fresh food temperature of approximately 38°F. Those units with a freezer section are designed to have a freezer temperature of approximately 0°F.

On units with ice makers, when the ice bucket is full, the ice making mechanism will shut off. However, the refrigeration system will continue to cool and maintain the cube supply. Frost free icemaker units have lower ice production than manual defrost units.

Ice production may be interrupted by raising the bin arm into an upright and locked position (the unit will maintain temperature for ice storage, see Figure 20).

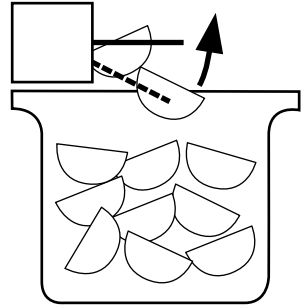

Figure 20

Certain sounds are normal during the unit's operation. You may hear the compressor or fan motor, the water valve, sounds of defrost, or ice dropping into the ice bucket.



### WARNING

**NEVER** use an ice pick, knife, or other sharp instrument to separate cubes. Shake the ice bucket instead.

The ice bucket **MUST** be fully inserted to avoid freezing products in the refrigerator section of the Combo 2075FF.

During periods of limited usage or high ambient temperatures, it is common for cubes to fuse together. Shake the bucket to break apart cubes.

If ice maker is not used regularly, the ice bucket should be emptied periodically to ensure fresh cubes.

It is normal for cubes to appear cloudy. This is caused by air being trapped in the water due to fast freezing. It has nothing to do with the health, taste or chemical make-up of the water. It is the same air that is in every glass of water you drink.

The ice bin door must be fully closed with the door lip inside the ice bucket.

Frost free models: Do not place any objects over air inlet or outlet in freezer section.

For frost free models: Light frosting may occur in high humidity conditions or if the ice bucket is not pushed in completely.

BI 2015 is not frost free and must be defrosted periodically. Refer to MAINTENANCE.

Do not place cans or bottles so they are touching the back of the unit. If placed against the evaporator section, cans or bottles may freeze.

## ADJUSTING THE TEMPERATURE CONTROL

### CONTROL KNOB

Series 2015 and 2075: Adjust control setting by turning the numbered knob attached to the front grille (see Figure 21).

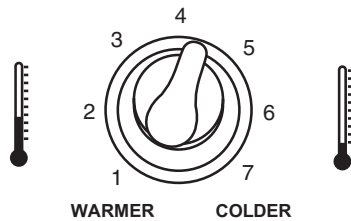

UL315

Figure 21

### CHECKING TEMPERATURE

To accurately check the temperature, insert an accurate thermometer into a plastic (non-breakable) bottle, partially filled with water. Tighten the bottle cap securely (see Figure 22).

Place the bottle in the desired area for 24 hours. Refrain from opening the unit during the testing period. After 24 hours, check the temperature of the water. Adjust the control knob if necessary and retest.

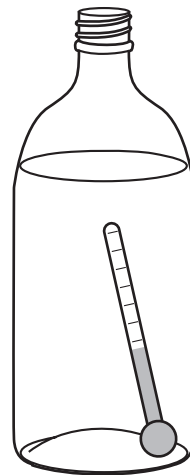

UL320

Figure 22

## OUTDOOR & MARINE USE

Many U-Line models are designed to operate in harsh outdoor/marine environments. Special considerations include the following:

- For best performance, keep the unit out of direct sunlight.
- On Ice Maker models, turn the unit OFF and dispose of any ice cubes if the unit will not be used for 5 days or more. Prop door open to allow for air circulation and prevent mold and mildew.
- If the ambient temperature is expected to drop below 45°F, drain all water from the unit to prevent freezing damage not covered by the warranty.
- High ambient temperatures (110°F or higher) may reduce the unit's ability to reach low temperatures and may also reduce the ice production rate.

## ADJUSTING ICE CUBE SIZE

On models equipped with an ice maker, the cube size may be adjusted by changing the amount of water injected into the ice maker assembly.

1. Remove the ice maker assembly cover (see Figure 23).
2. Locate the adjusting screw on the ice maker assembly control box. The adjusting screw is just below the minus (-) and plus (+) signs on the control box (see Figure 24).

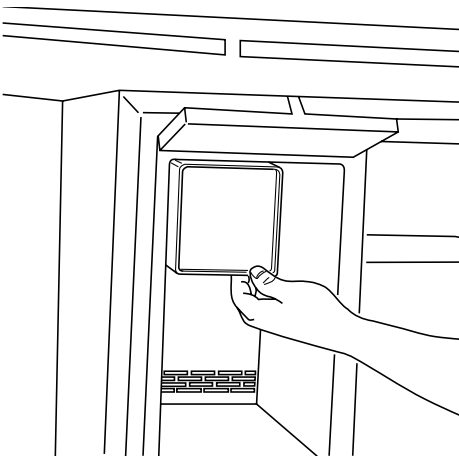
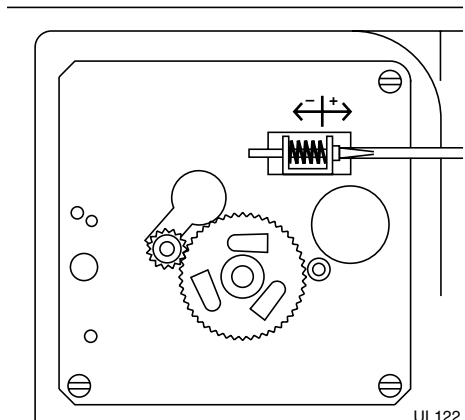

Figure 23



UL122

Figure 24

3. Turn the adjusting screw toward the minus (-) sign (clockwise) for smaller cubes or toward the plus (+) sign (counterclockwise) for larger cubes.
4. Install the ice maker assembly cover.

## MAINTENANCE

Periodic cleaning and proper maintenance will ensure efficiency, top performance, and long life. The maintenance intervals listed are based on normal conditions. You may want to shorten the intervals if you have pets, the unit is used outdoors, or other special considerations.

### EXTERIOR CLEANING — AS REQUIRED

The door, grille and cabinet may be cleaned with a mild detergent and warm water solution. Do not use solvent based or abrasive cleaners. Use a soft sponge and rinse with clean water. Wipe with a soft, clean towel to prevent water spotting.

Stainless steel models can discolor when exposed to chlorine gas and should be cleaned. Clean stainless steel models with a mild detergent and warm water solution and a damp cloth. Never use abrasive cleaning agents.



### CAUTION

Stainless steel models exposed to chlorine gas and moisture, such as areas with spas or swimming pools, may have some discoloration of the stainless steel. Discoloration from chlorine gas is normal.

### INTERIOR CLEANING — AS REQUIRED

1. Disconnect power to the unit.
2. Remove shelves if desired, see GLASS SHELF REMOVAL/INSTALLATION.
3. Open the door and remove any ice from the storage bin (if equipped).
4. Wipe down the interior with a solution of non-abrasive mild detergent and warm water.
5. Rinse thoroughly with clear water.
6. Reconnect power to the unit.

# User's Manual



## WARNING

- DO NOT use solvent cleaning agents or abrasives on the interior. These cleansers may transmit taste to the ice cubes, or damage or discolor the interior.

## CONDENSER CLEANING - EVERY 3 MONTHS



## WARNING



Disconnect electric power to the unit before cleaning the condenser.

To remove and replace the grille for access to the condenser fins follow this procedure:

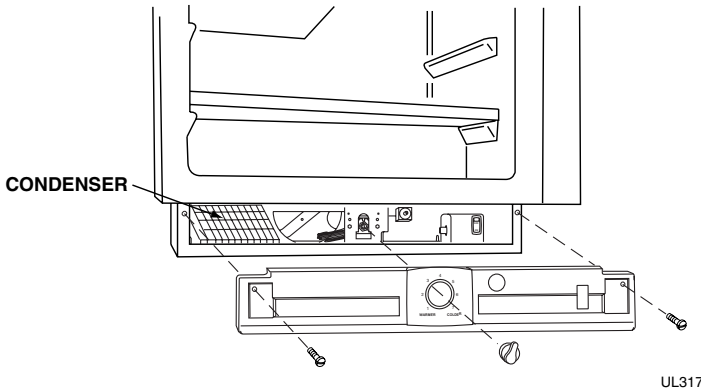

Figure 25

1. Remove the control knob by grasping the knob and pulling straight off (see Figure 25).

2. Remove the screws at each end of the grille.
3. Remove the grille.



## WARNING

**DO NOT touch the condenser fins. The condenser fins are SHARP and can be easily damaged.**

4. Clean the condenser coil using a brush or vacuum cleaner. Do not touch.
5. Position the grille to align the screw holes with the cabinet.
6. Insert the grille screws and tighten being careful not to overtighten.
7. Install the control knob by aligning the flat of the control knob with the flat on the shaft. Push firmly.

## INLET SCREEN CLEANING

The solenoid valve inlet screen must be cleaned at least once each year as follows:

1. Shut off the water at the water supply valve.
2. Remove the entire hose connector from the solenoid valve.

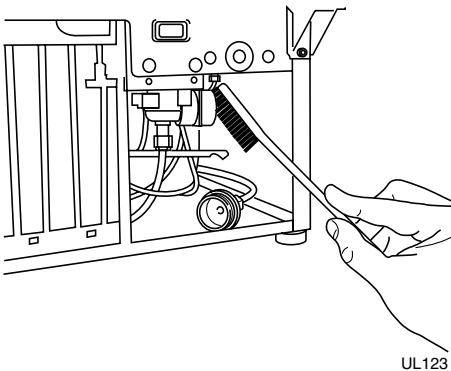

3. Use a tooth brush to clean sediment from the inlet screen (see Figure 26). DO NOT remove the screen.
4. Attach the hose connector to the solenoid valve. Tighten connector securely with a pliers. Open the water supply valve and check for leakage at the hose connector.

Figure 26

# User's Manual

## GLASS SHELF REMOVAL/INSTALLATION

Removal (see Figure 27)

1. Pull shelf out about 6" until back of shelf clears the "hump" on the right hand side.
2. Tilt right hand edge of shelf up.
3. Remove shelf from unit by pulling out.

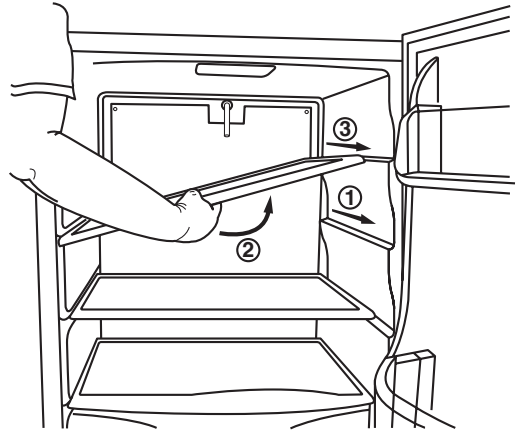

Figure 27

UL301

### Adjustment/Installation

1. To move to a different position in the unit, insert shelf at an angle, approximately 15-20°, over the rib in the side of the unit where you want to place the shelf. The shelf must be started into the unit at an angle to clear the door.
2. Continue to slide the shelf into the unit at an angle until it clears the door. Lower the shelf and rest it on the rib.

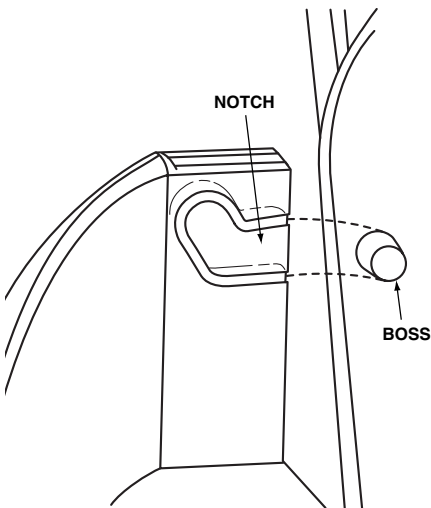

Figure 28

UL303

## DOOR SHELF REMOVAL/INSERTION

To Remove Door Shelf (see Figure 28):

1. Grasp shelf in center, lift slightly, and tilt 15°-20°.
2. Carefully pull shelf off bosses.

To Install Door Shelf:

1. Holding shelf in center, align notches in shelf with bosses in door.
2. Tilt shelf at a 15°-20° angle and slide onto bosses at the desired location.



## CRISPER

### CAUTION

Slowly pull out the crisper. If it is pulled out too far, it could come out all the way and possibly cause damage or injury.

Combo 2075FF, 2075R and 2075RF models have a crisper for storage. Grasp the crisper handle and pull out to access the contents (see Figure 29). The crisper may be completely removed for cleaning.

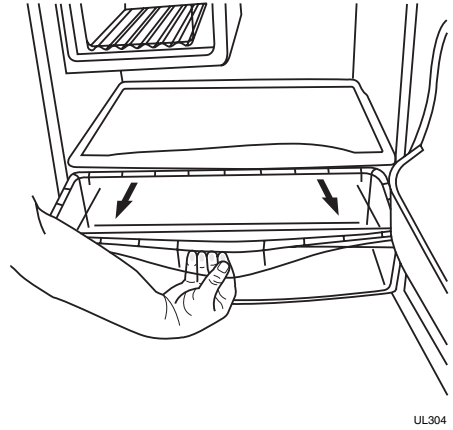

UL304

Figure 29

## LIGHT BULB REPLACEMENT

Light bulb replacement in the Échelon™ series is simple.

1. Remove the light housing cover by sliding the cover toward the tab, swinging the end opposite the tab down and pulling down and away (see Figure 30).
2. Replace bulb with genuine U-Line replacement.
3. Replace the light housing cover by inserting the tab FIRST, sliding the cover toward the tab and pushing up the other end. You should hear a snap/click.

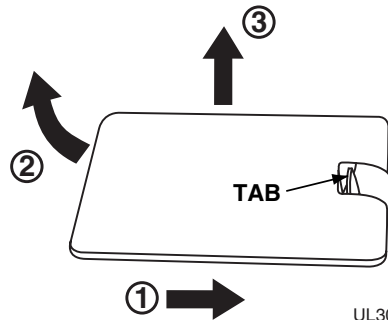

UL305

Figure 30

## DEFROSTING



### WARNING

**DO NOT** use any type of electrical heating device, ice pick, knife, or other sharp instrument to defrost. Doing so may cause personal injury or damage the inner lining or refrigeration system and void the warranty.

BI 2015 is a manual defrost model and should be defrosted approximately every 8 weeks. However, this interval may not be adequate in periods of high humidity or heavy usage. Defrost your unit whenever the frost thickness is 1/4" or greater. To defrost, turn the unit OFF, remove cubes and prop door open at least two inches.

### NOTE

Frost free units will never need defrosting. Cycle defrost models do not normally require manual defrosting. However, in extremely high humidity or during periods of unusually high usage, minimal manual defrosting may be required.

## STORAGE

If the unit is to be stored or not used for extended periods, it will be necessary to drain the system of water.

1. Shut off water supply at the main water source.
2. Disconnect the water supply line from the solenoid valve.
3. Disconnect the water line from the solenoid valve outlet.
4. Allow the unit to run for an hour or more until all remaining ice cubes have been ejected from the ice maker assembly.
5. Dry out excess water from the ice maker assembly.
6. Prop the door open at least two inches to allow for air circulation and prevent mold and mildew.
7. Disconnect unit from main electrical power source.
8. Leave water supply line and power cord disconnected until ready to reuse.

### NOTE

The use of anti-freeze or other products of this nature is not necessary and is not recommended.

## TROUBLESHOOTING

### BEFORE CALLING FOR SERVICE

If the unit appears to be malfunctioning, read through NORMAL OPERATION first. If the problem persists, check the TROUBLESHOOTING GUIDE. Locate the problem in the guide and refer to the cause and its remedy before calling for service. The problem could be something very simple which can be solved without a service call.

### TROUBLESHOOTING GUIDE



## DANGER



### ELECTROCUTION HAZARD

**NEVER** attempt to repair or perform maintenance on the unit until the main electrical power has been disconnected.

### Troubleshooting — What to check when problems occur

Problem	Possible Cause	Remedy
No interior light.	Loose or burned out bulb.	Tighten or replace bulb. See page 23 for light replacement instructions.
The unit is not cold enough.	Light staying on.	Call for service.
	Inaccurate temperature reading.	Properly check temperature. See page 17.
	Dirty condenser coils.	Clean condenser. See CARE AND CLEANING.
	Airflow to front grille blocked.	Airflow must not be obstructed to front grille. See INSTALLATION.
	Temperature not set cold enough.	Turn control knob CLOCKWISE to set temperature colder. Allow 24 hours for temperature to stabilize.

<b>Problem</b>	<b>Possible Cause</b>	<b>Remedy</b>
The unit frosts up.	Unit is manual defrost model.	Model B2015 is a manual defrost. Refer to DEFROSTING.
	High ambient temperatures or humidity.	Defrost unit manually. See DEFROSTING.
Water is leaking out the back of the unit.	Water supply connection leaking.	Tighten fitting. See CONNECTING THE WATER SUPPLY.
Ice cubes sticking together.	Infrequent use of cubes.	Break apart cubes.
Noise during operation.	Copper water supply tubing contacting internal components.	Carefully bend tubing away from cabinet and components.
	Certain sounds are normal.	Soft sounds from the fan and water/dropping sounds from the ice maker will be heard.
No ice.	Bin arm locked in upright position.	Lower bin arm.
	No water to unit.	Turn on water or contact plumber.
Not enough ice.	Ice cube size too large.	Set cube size smaller. See ADJUSTING ICE CUBE SIZE.
	Dirty condenser coils.	Clean condenser. See MAINTENANCE.
Water leaks into ice bucket.	Water level set too high.	Set cube size smaller. See ADJUSTING ICE CUBE SIZE.
Fresh food section on Combo units too cold.	Ice bucket not fully inserted.	Push ice bucket into place.
	Flap door not closed correctly.	Be sure Flap door is closed correctly.
	Temperature control set too cold.	Set control to warmer setting (COUNTER-CLOCKWISE).
	Inaccurate temperature reading.	Properly check temperature. See Page 17.

## IF SERVICE IS REQUIRED

If the need for service arises, contact the dealer from whom the unit was purchased. State the Model Number and Serial Number and explain the problem. The Model and Serial Number plate is located inside unit at upper right hand corner.





**U-LINE**  
CORPORATION

*P. O. Box 245040*

*Milwaukee, WI 53224-9540*

*Phone: 414.354.0300*

*Fax: 414.354.7905*

*[www.u-line.com](http://www.u-line.com)*