

PRO-FORM[®]

300 CR

www.proform.com

Model No. PFEX63910.1

Serial No. _____

Write the serial number in the space above for reference.

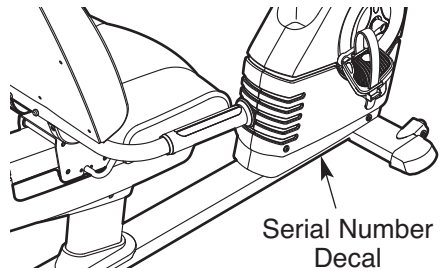

USER'S MANUAL

QUESTIONS?

If you have questions, or if parts are damaged or missing, **DO NOT CONTACT THE STORE**; please contact Customer Care.

IMPORTANT: Please register this product (see the limited warranty on the back cover of this manual) before contacting Customer Care.

CALL TOLL-FREE:

1-888-533-1333

Mon.–Fri., 6 a.m.–6 p.m. MT

Sat. 8 a.m.–4 p.m. MT

ON THE WEB:

www.proformservice.com

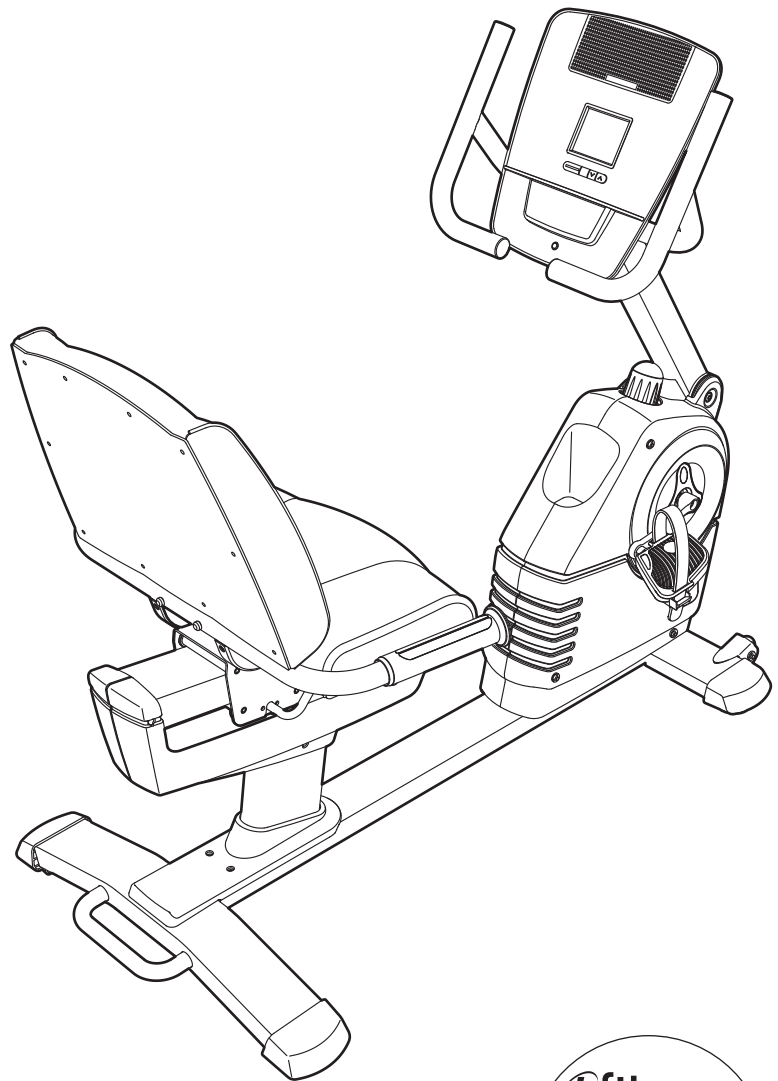

⚠ CAUTION

Read all precautions and instructions in this manual before using this equipment. Keep this manual for future reference.

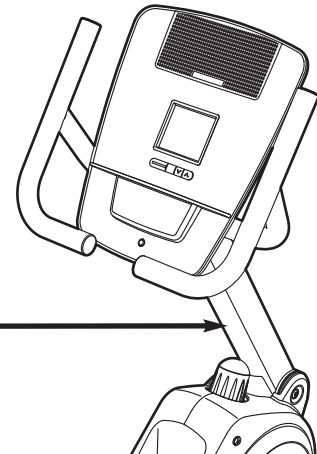
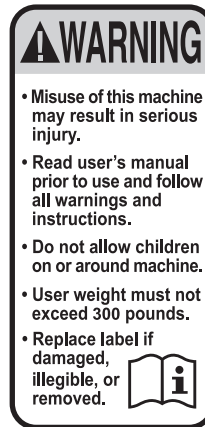

TABLE OF CONTENTS

WARNING DECAL PLACEMENT2
IMPORTANT PRECAUTIONS3
BEFORE YOU BEGIN4
PART IDENTIFICATION CHART5
ASSEMBLY6
HOW TO USE THE EXERCISE BIKE12
MAINTENANCE AND TROUBLESHOOTING18
FCC INFORMATION20
EXERCISE GUIDELINES21
PART LIST24
EXPLODED DRAWING26
ORDERING REPLACEMENT PARTSBack Cover
LIMITED WARRANTYBack Cover

WARNING DECAL PLACEMENT

This drawing shows the location(s) of the warning decal(s). **If a decal is missing or illegible, see the front cover of this manual and request a free replacement decal. Apply the decal in the location shown.** Note: The decal(s) may not be shown at actual size.



IMPORTANT PRECAUTIONS

⚠ WARNING: To reduce the risk of serious injury, read all important precautions and instructions in this manual and all warnings on your exercise bike before using your exercise bike. ICON assumes no responsibility for personal injury or property damage sustained by or through the use of this product.

1. Before beginning any exercise program, consult your physician. This is especially important for persons over age 35 or persons with pre-existing health problems.
2. Use the exercise bike only as described in this manual.
3. It is the responsibility of the owner to ensure that all users of the exercise bike are adequately informed of all precautions.
4. The exercise bike is intended for home use only. Do not use the exercise bike in a commercial, rental, or institutional setting.
5. Keep the exercise bike indoors, away from moisture and dust. Do not put the exercise bike in a garage or covered patio, or near water.
6. Place the exercise bike on a level surface with at least 2 ft. (0.6 m) of clearance around the exercise bike. To protect the floor or carpet from damage, place a mat under the exercise bike.
7. Inspect and properly tighten all parts regularly. Replace any worn parts immediately.
8. Keep children under age 12 and pets away from the exercise bike at all times.
9. Wear appropriate clothes while exercising; do not wear loose clothes that could become caught on the exercise bike. Always wear athletic shoes for foot protection.
10. The exercise bike should not be used by persons weighing more than 300 lbs. (136 kg).
11. The pulse sensor is not a medical device. Various factors, including the user's movement, may affect the accuracy of heart rate readings. The pulse sensor is intended only as an exercise aid in determining heart rate trends in general.
12. Always keep your back straight while using the exercise bike; do not arch your back.
13. Over exercising may result in serious injury or death. If you feel faint or if you experience pain while exercising, stop immediately and cool down.

BEFORE YOU BEGIN

Thank you for selecting the revolutionary PROFORM® 300 CR exercise bike. Cycling is an effective exercise for increasing cardiovascular fitness, building endurance, and toning the body. The 300 CR exercise bike provides an impressive selection of features designed to make your workouts at home more effective and enjoyable.

For your benefit, read this manual carefully before you use the exercise bike. If you have questions

after reading this manual, please see the front cover of this manual. To help us assist you, note the product model number and serial number before contacting us. The model number and the location of the serial number decal are shown on the front cover of this manual.

Before reading further, please familiarize yourself with the parts that are labeled in the drawing below.

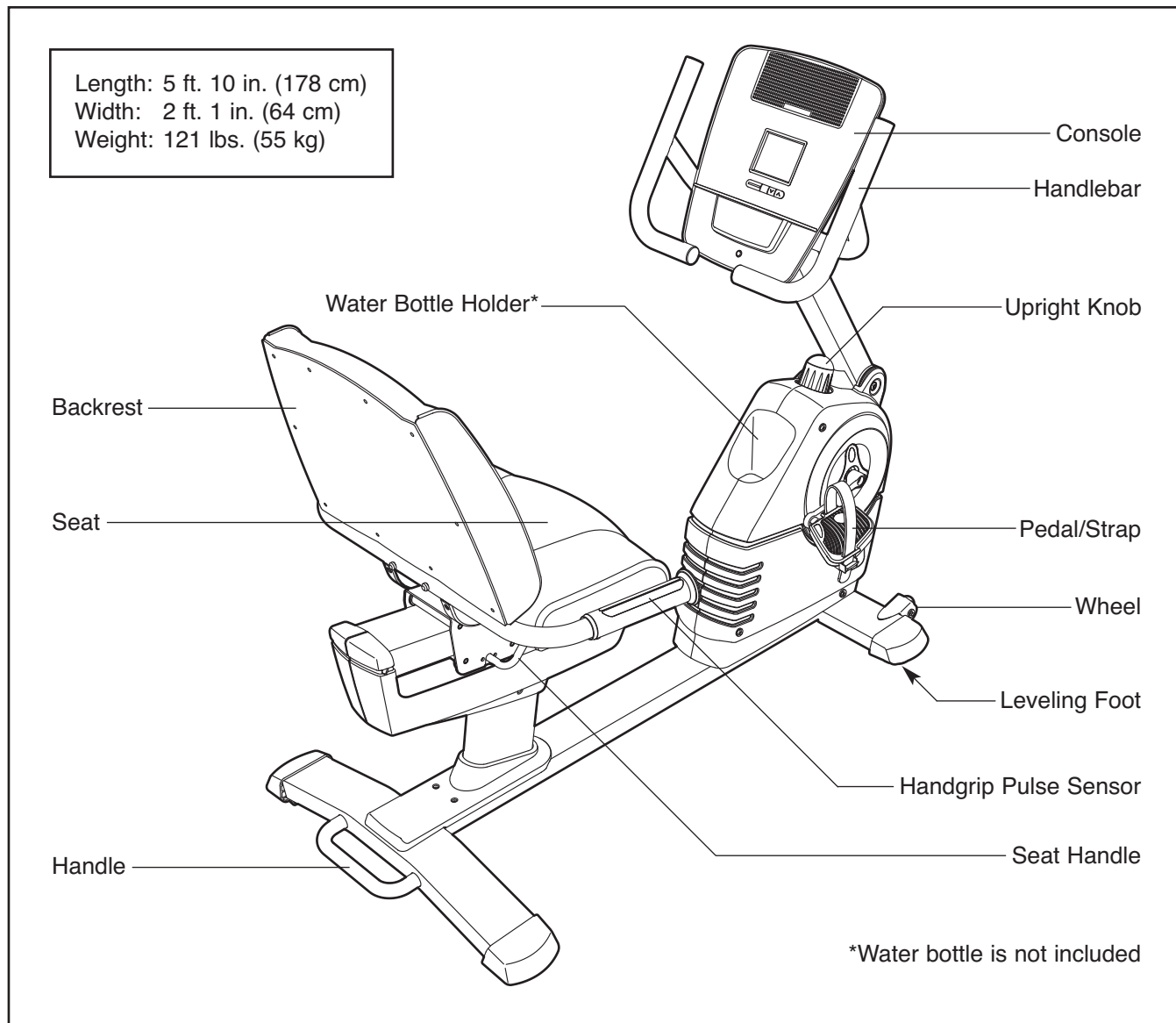

PART IDENTIFICATION CHART

See the drawings below to identify the small parts needed for assembly. The number in parentheses below each drawing is the key number of the part, from the PART LIST near the end of this manual. The number following the key number is the quantity needed for assembly. **Note: If a part is not in the hardware kit, check to see if it has been preassembled. To avoid damaging parts, do not use power tools for assembly.**

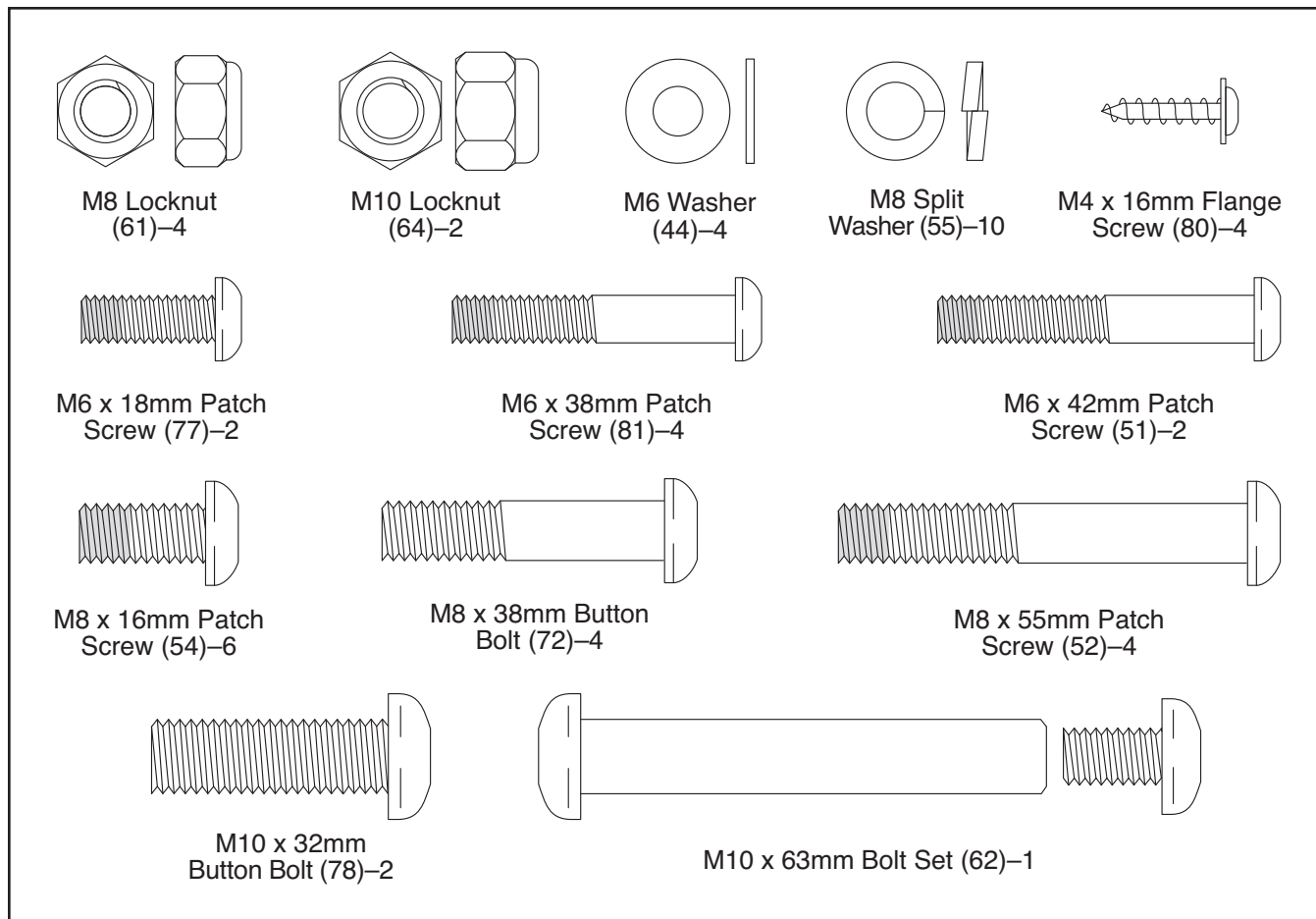

ASSEMBLY

- To hire an authorized service technician to assemble the exercise bike, call 1-800-445-2480.
- Assembly requires two persons.
- Place all parts in a cleared area and remove the packing materials. Do not dispose of the packing materials until you complete all assembly steps.

- To identify small parts, see page 5.
- In addition to the included tool(s), assembly requires the following tools:

one adjustable wrench



one Phillips screwdriver



Assembly may be easier if you have a socket set or a set of ratchet wrenches. To avoid damaging parts, do not use power tools.

1. Orient the Right Front Stabilizer (40) with the Wheel (17) positioned as shown.

Attach the Right Front Stabilizer (40) to the right side of the Frame (1) with three M8 x 16mm Patch Screws (54) and three M8 Split Washers (55).

Attach the Left Front Stabilizer (not shown) to the left side of the Frame (1) in the same way.

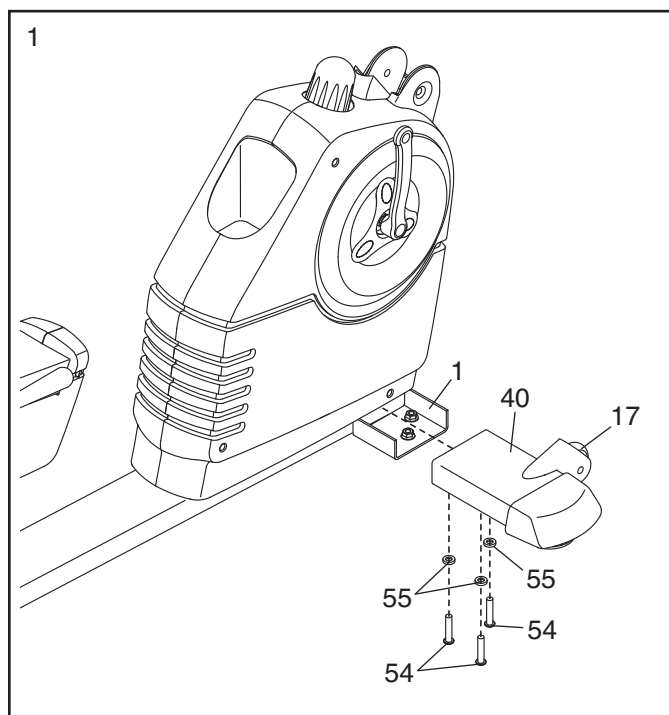

2. While another person lifts the rear of the Frame (1), attach the Rear Stabilizer (16) to the Frame with four M8 x 55mm Patch Screws (52) and four M8 Split Washers (55).

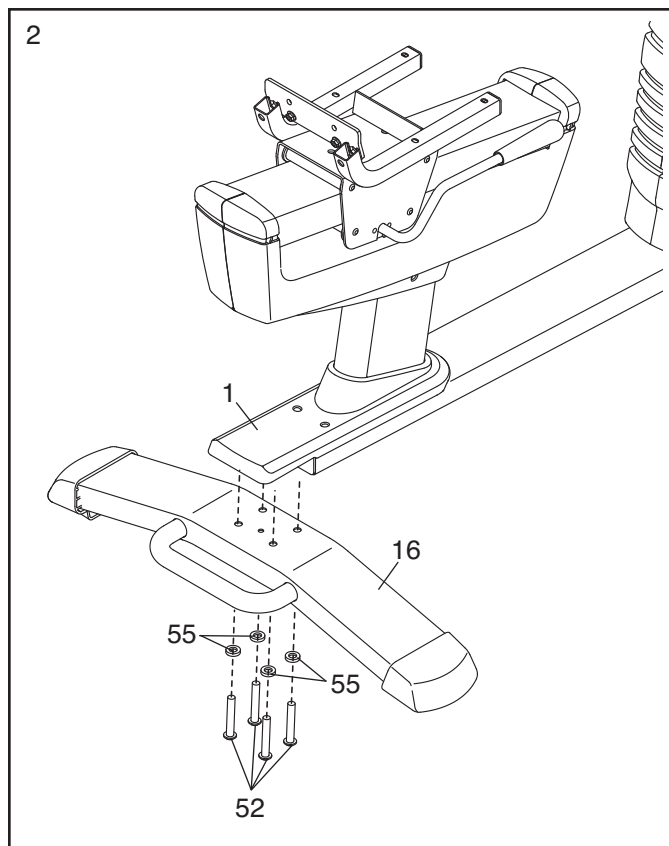

3. While another person holds the Upright (2) near the Frame (1), locate the wire tie in the Upright.

See the inset drawing. Tie the lower end of the wire tie to the Pulse Extension Wire (79) and to the Main Wire Harness (43). Next, pull the other end of the wire tie upward out of the top of the Upright (2).

Tip: Do not allow the ends of the wires to fall into the Upright (2). Use the wire tie to hold the wires in place until step 6.

Tip: Avoid pinching the wires. Attach the Upright (2) to the Frame (1) with an M10 x 63mm Bolt Set (62).

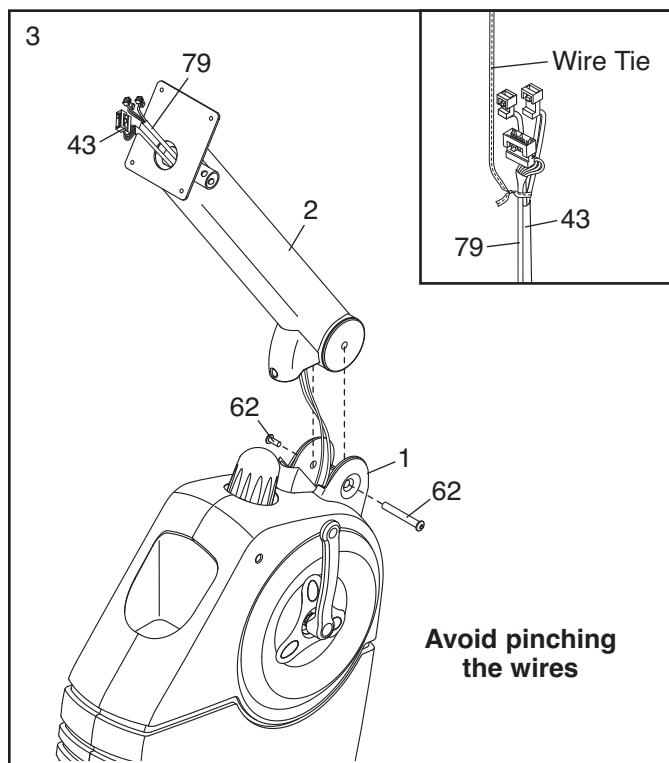

4. Identify the Right and Left Handlebars (59, 60), which are marked with "Right" and "Left" stickers.

Orient the Right and Left Handlebars (59, 60) so that the hexagonal holes are in the indicated locations.

Attach each Handlebar (59, 60) to the Upright (2) with two M8 x 38mm Button Bolts (72) and two M8 Locknuts (61). **Make sure that the Locknuts are in the hexagonal holes.**

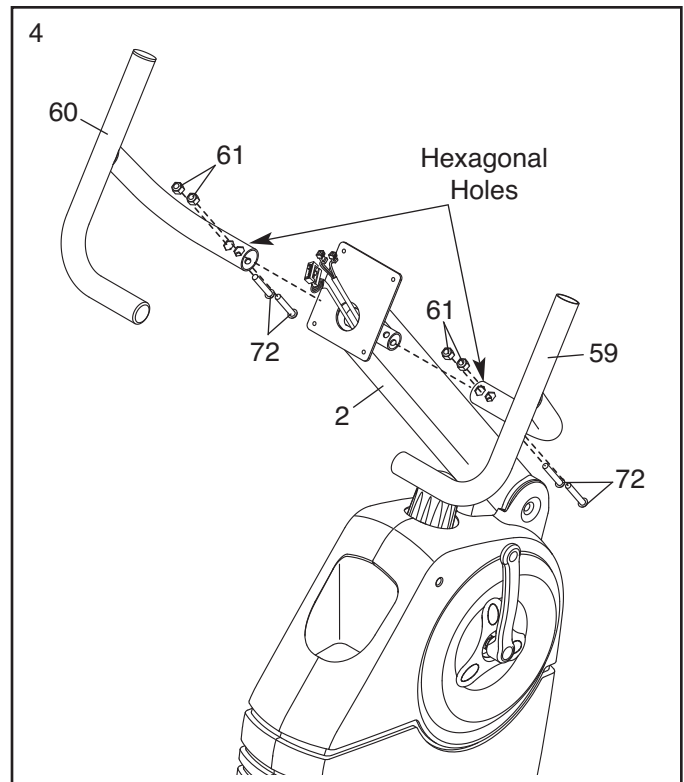

5. The Console (4) can use four 1.5V D batteries (not included); alkaline batteries are recommended. **IMPORTANT: If the Console has been exposed to cold temperatures, allow it to warm to room temperature before inserting batteries. Otherwise, you may damage the console displays or other electronic components.** Remove the screw, remove the battery cover, and insert the batteries into the battery compartment. **Make sure to orient the batteries as shown by the diagrams inside the battery compartment.** Then, reattach the battery cover.

To purchase an optional power adapter, call the telephone number on the cover of this manual. To avoid damaging the console, use only a manufacturer-supplied power adapter. Plug one end of the power adapter into the receptacle on the console; plug the other end into an outlet installed in accordance with all local codes and ordinances.

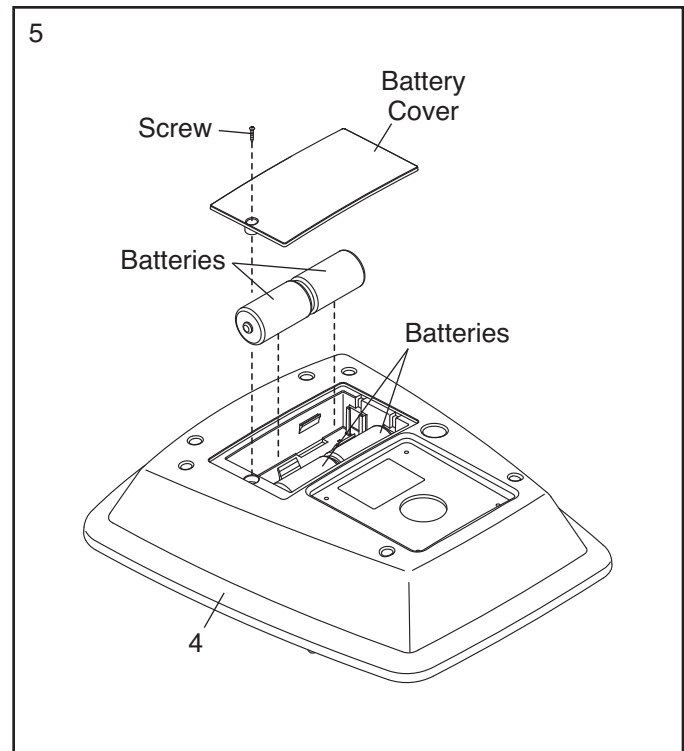

- Untie and discard the wire ties on the Main Wire Harness (43) and the Pulse Extension Wire (79).

While another person holds the Console (4) near the Upright (2), connect the wires on the Console to the Main Wire Harness (43) and to the Pulse Extension Wire (79).

Insert the excess wire into the Upright (2) or into the Console (4).

Tip: Avoid pinching the wires. Attach the Console (4) to the Upright (2) with four M4 x 16mm Flange Screws (80).

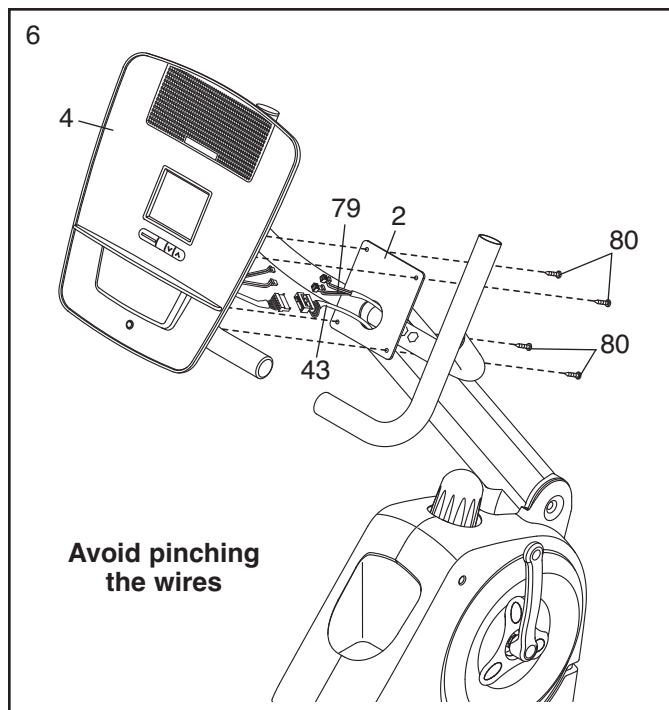

- Identify and orient the Seat Handlebar (11) so that the contacts on the Pulse Grips (10) face upward. **Make sure that the hexagonal holes are in the indicated locations.**

Tip: Avoid pinching the Pulse Wire (58). Attach the Seat Handlebar (11) to the Seat Carriage (3) with two M10 x 32mm Button Bolts (78) and two M10 Locknuts (64). **Do not fully tighten the Locknuts yet.**

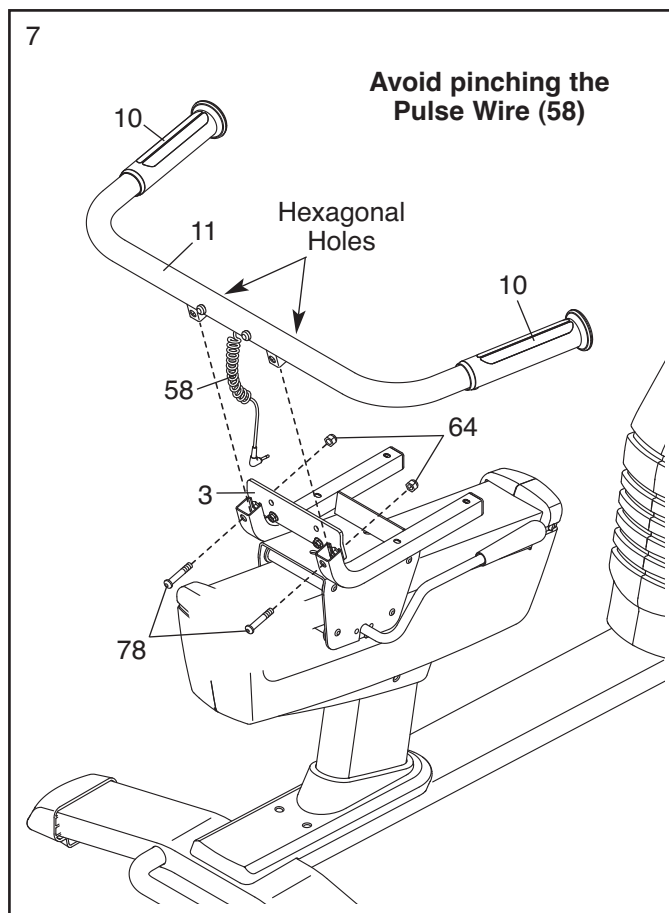

8. **Tip: Avoid pinching the Pulse Wire (58).**
Attach the Backrest (8) to the Seat Carriage (3) with two M6 x 18mm Patch Screws (77) and two M6 x 42mm Patch Screws (51).

Tip: First tighten the M6 x 18mm Patch Screws (77), and then tighten the M6 x 42mm Patch Screws (51).

See step 7. Tighten the M10 Locknuts (64).

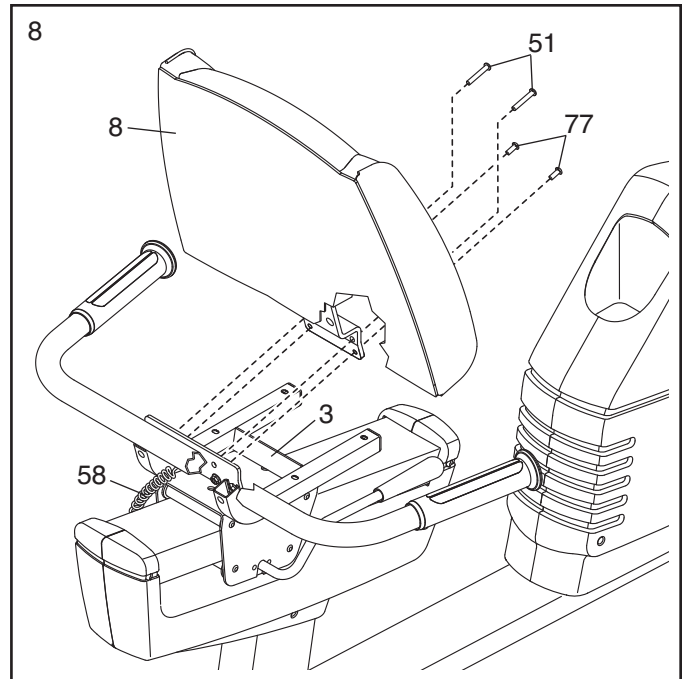

9. Attach the Seat (9) to the Seat Carriage (3) with four M6 x 38mm Patch Screws (81) and four M6 Washers (44) (only two of each are shown).
Note: The Patch Screws and Washers may be preattached to the underside of the Seat.

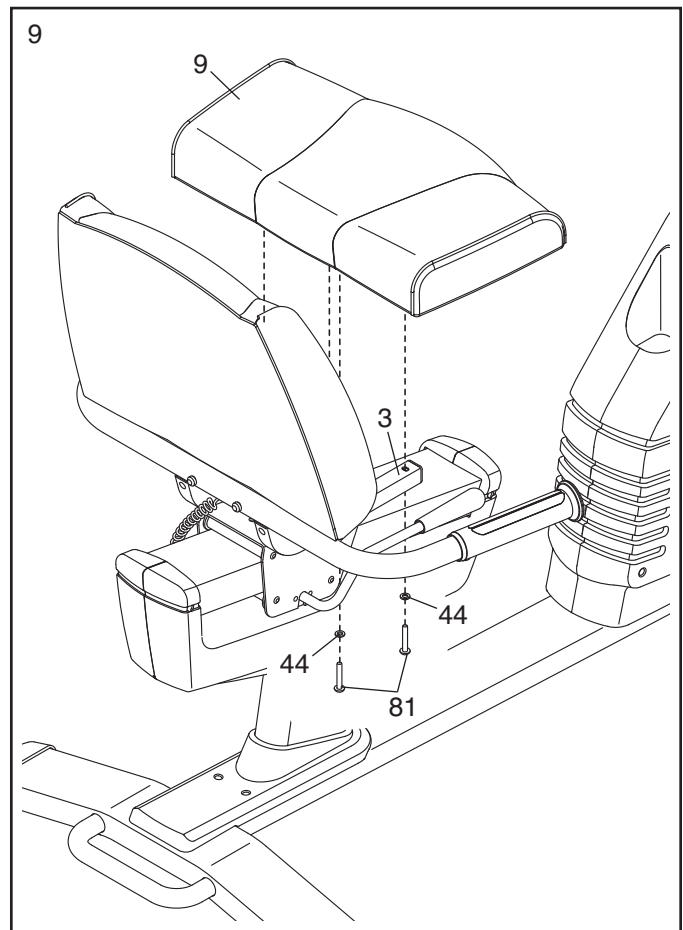

10. Plug the Pulse Wire (58) into the Pulse Receptacle (79) located in the Left Shield (26).

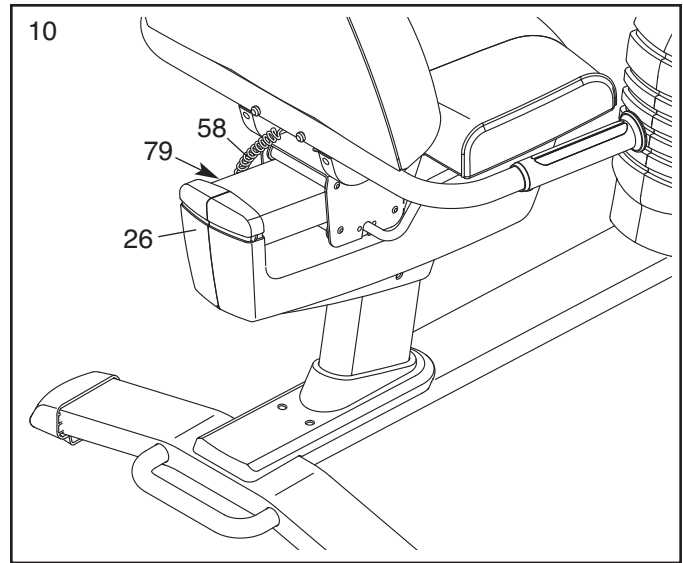

11. Identify the Right Pedal (21), which is marked with an "R." Using an adjustable wrench, **firmly tighten** the Right Pedal **clockwise** into the Right Crank (23).

Tighten the Left Pedal (not shown) **counter-clockwise** into the Left Crank (not shown).

Adjust the strap on the Right Pedal (21) to the desired position, and press the ends of the strap onto the tab on the Right Pedal. **Adjust the strap on the Left Pedal (not shown) in the same way.**

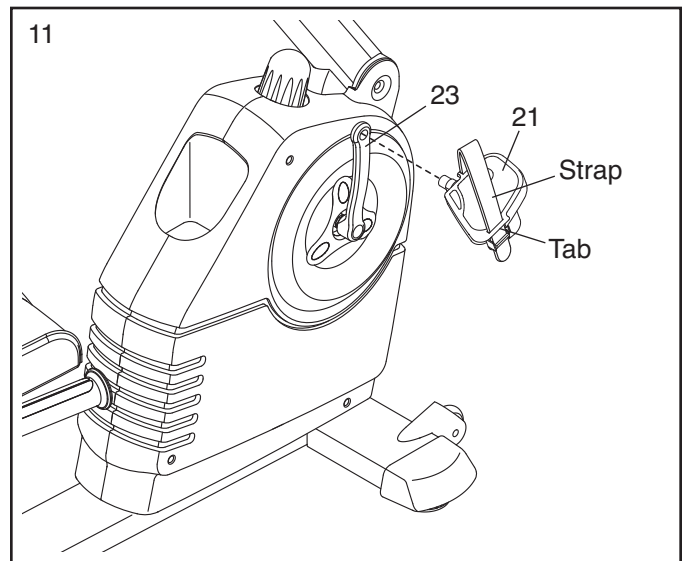

12. **Make sure that all parts are properly tightened before you use the exercise bike.** Note: After assembly is completed, some extra parts may be left over. Place a mat beneath the exercise bike to protect the floor.

HOW TO USE THE EXERCISE BIKE

HOW TO ADJUST THE PEDAL STRAPS

To adjust the pedal straps, first pull the ends of the straps off the tabs on the pedals. Adjust the straps to the desired position, and then press the ends of the straps onto the tabs.

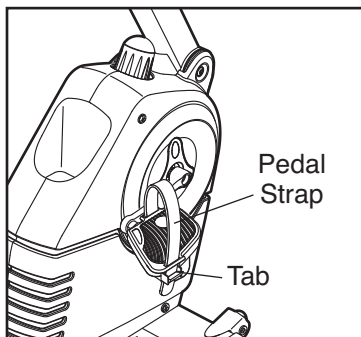

HOW TO ADJUST THE SEAT

The seat can be adjusted forward or backward to the position that is the most comfortable for you. To adjust the seat, push downward on the seat handle, slide the seat to the desired position, and then pull upward on the seat handle to lock the seat in place.

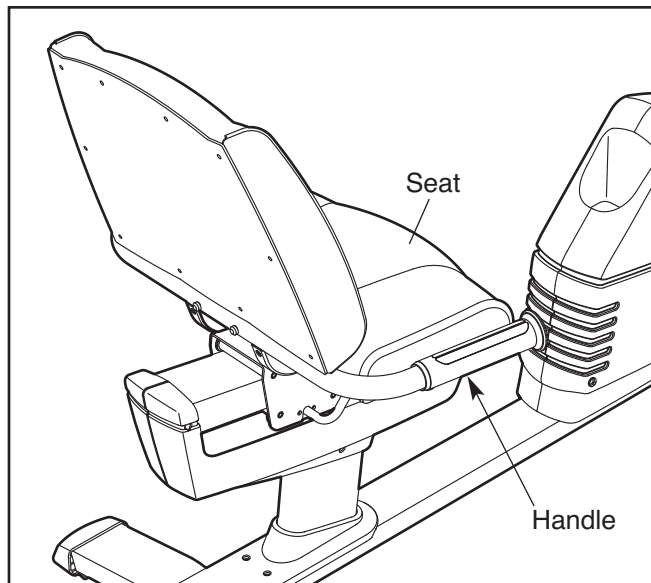

HOW TO LEVEL THE EXERCISE BIKE

If the exercise bike rocks slightly on your floor during use, turn one or both of the leveling feet under the front stabilizers until the rocking motion is eliminated.

HOW TO ADJUST THE UPRIGHT

The upright can be adjusted to the position that is the most comfortable for you. To adjust the upright, first raise the upright so that it is not resting on the upright knob. Next, turn the upright knob clockwise or counter-clockwise to raise or lower the upright. Then, rest the upright on the upright knob.

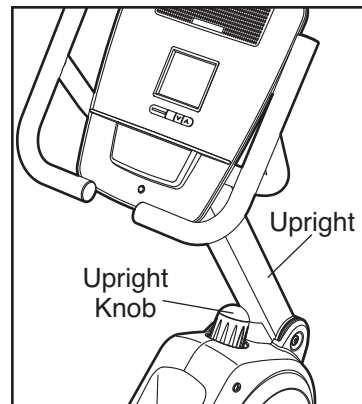

HOW TO MOVE THE EXERCISE BIKE

To move the exercise bike, hold the handle on the rear stabilizer and carefully lift the handle until the exercise bike can be moved on the front wheels. Carefully move the exercise bike to the desired location and then lower it to the floor.

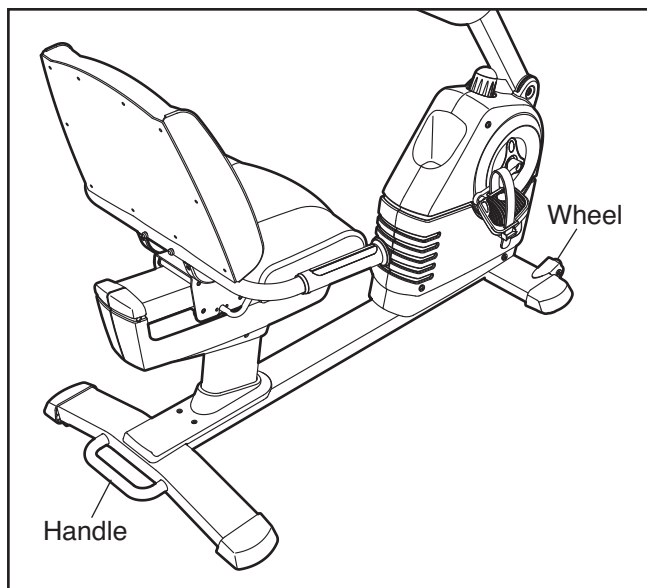

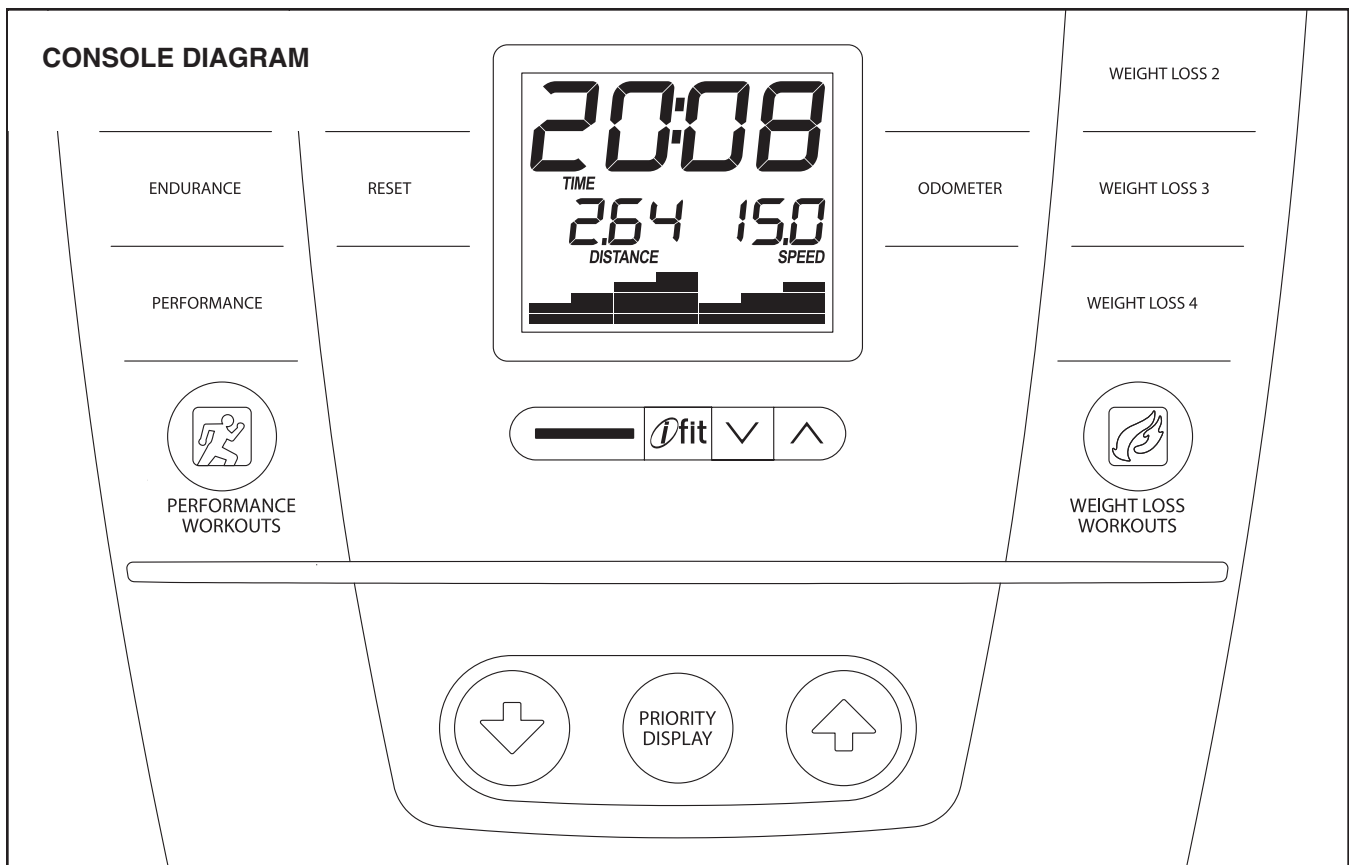

FEATURES OF THE CONSOLE

The advanced console offers an array of features designed to make your workouts more effective and enjoyable.

When you use the manual mode of the console, you can change the resistance of the pedals with the touch of a button. While you exercise, the console will display continuous exercise feedback. You can also measure your heart rate using the handgrip pulse sensor.

In addition, the console offers twenty preset workouts—sixteen performance and four weight loss workouts. Each workout automatically changes the resistance of the pedals as it guides you through an effective workout.

The console features the iFit interactive workout system, which enables the console to accept iFit cards containing workouts designed to help you achieve specific fitness goals.

For example, lose unwanted pounds with the 8-week Weight Loss workout. iFit workouts control the resistance of the pedals while the voice of a personal trainer coaches you through your workouts. iFit cards are available separately. **To purchase iFit cards, go to www.iFit.com or call the telephone number on the front cover of this manual. iFit cards are also available at select stores.**

You can even connect your MP3 player or CD player to the console sound system and listen to your favorite music or audio books while you exercise.

To use the manual mode, see page 14. **To use a preset workout**, see page 15. **To use an iFit workout**, see page 16. **To use the sound system**, see page 17. **To change console settings**, see page 17.

Note: Before using the console, make sure that batteries are installed (see assembly step 5 on page 8). If there is a sheet of plastic on the display, remove the plastic.

HOW TO USE THE MANUAL MODE

1. **Begin pedaling or press any button on the console to turn on the console.**

A moment after you begin pedaling or press a button, a tone will sound, and the display will turn on.

2. **Select the manual mode.**

Each time you turn on the console, the manual mode will be selected. If you have selected a workout, reselect the manual mode by pressing any of the Workouts buttons repeatedly until zeros appear in the display.

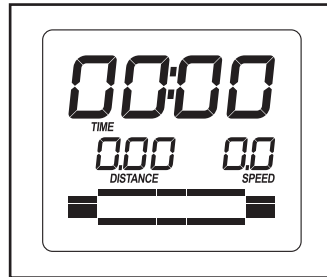

3. **Change the resistance of the pedals as desired.**

As you pedal, change the resistance of the pedals by pressing the Silent Magnetic Resistance

increase and decrease buttons. Note: After you press the buttons, it will take a moment for the pedals to reach the selected resistance level.



4. **Follow your progress with the display.**

The lower left display—As you exercise, the lower left display can show the elapsed time and the distance that you have pedaled in miles or kilometers.



Note: When a workout is selected, the display will show the time remaining in the workout instead of the elapsed time.

The lower right display—The lower right display can show your pedaling speed in miles per hour or kilometers per hour and the approximate number of calories that you have burned.



The display also shows your heart rate when you use the handgrip pulse sensor (see step 5 on page 15).

The upper display—The upper display can show the elapsed time, the distance that you have pedaled, your pedaling speed, and the approximate number of calories you have burned.



Press the Priority Display button repeatedly until the upper display shows the information that you are most interested in viewing. Note: While information is shown in the upper display, the same information will not be shown in the lower left or lower right display.

The lower display—The lower display will show a track representing 1/4 mile (400 meters). As you exercise, indicators will appear in succession around the track until the entire track appears. The track will then disappear and the indicators will again begin to appear in succession.

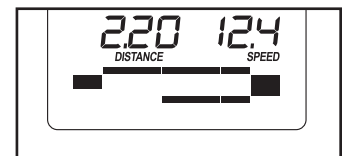

To view the trip distance, press the Odometer button once. To reset the trip distance to zero, press the Reset button.

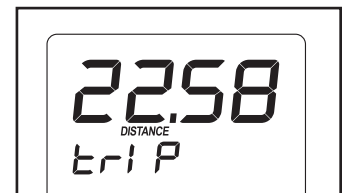

To view the total distance pedaled since the exercise bike was purchased, press the Odometer button a second time. To exit the odometer information, press the Odometer button a third time.

Note: The console can show pedaling pace and distance in either miles or kilometers. To view or change the unit of measurement, see HOW TO CHANGE CONSOLE SETTINGS on page 17.

5. Measure your heart rate if desired.

If there are sheets of plastic on the metal contacts on the handgrip pulse sensor, remove the plastic. To measure your heart rate, hold the handgrip pulse sensor with your palms resting against the metal contacts. **Avoid moving your hands or gripping the contacts tightly.**

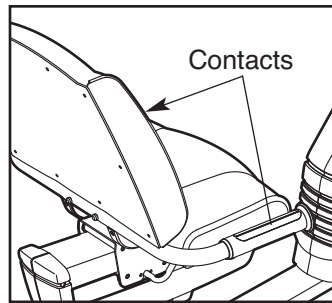

When your pulse is detected, a flashing heart symbol will appear in the display, and then your heart rate will appear. For the most accurate heart rate reading, hold the contacts for at least 15 seconds. Note: If you continue to hold the handgrip pulse sensor, the display will show your heart rate for up to 30 seconds.



If the display does not show your heart rate, make sure that your hands are positioned as described. Be careful not to move your hands excessively or to squeeze the metal contacts tightly. For optimal performance, clean the metal contacts using a soft cloth; **never use alcohol, abrasives, or chemicals to clean the contacts.**

6. When you are finished exercising, the console will turn off automatically.

If the pedals do not move for several seconds, a tone will sound and the console will pause.

If the pedals do not move for several minutes and the buttons are not pressed, the console will turn off and the display will be reset.

HOW TO USE A PRESET WORKOUT

1. Begin pedaling or press any button on the console to turn on the console.

A moment after you begin pedaling or press a button, a tone will sound, and the display will turn on.

2. Select a preset workout.

To select a performance workout, press the Warm Up, Aerobic, Endurance, or Performance button repeatedly until the name of the desired workout appears in the display. To select a weight loss workout, press the desired Weight Loss button.

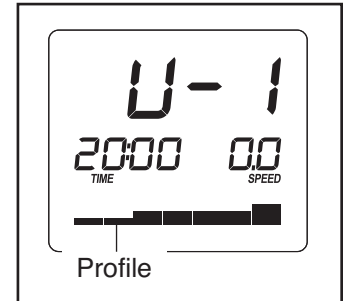

The workout time and a profile of the resistance levels for the workout will also appear in the display.

3. Begin pedaling to start the workout.

Each workout is divided into one-minute segments. One resistance level is programmed for each segment. Note: The same resistance level may be programmed for consecutive segments.

The resistance level for the first segment will appear in the display for a few seconds. During the workout, the workout profile will show your progress (see the drawing above).

The flashing segment of the profile represents the current segment of the workout. The height of the flashing segment indicates the resistance level for the current segment. At the end of each segment of the workout, a series of tones will sound and the next segment of the profile will begin to flash. If a different resistance level is programmed for the next segment, the resistance level will appear in the display for a few seconds to alert you. The resistance of the pedals will then change.

If the resistance level for the current segment is too high or too low, you can manually override the setting by pressing the Silent Magnetic Resistance buttons. **IMPORTANT: When the current segment of the workout ends, the pedals will automatically adjust to the resistance level programmed for the next segment.**

The workout will continue in this way until the last segment ends. To stop the workout at any time, stop pedaling. A tone will sound and the time will stop counting. To restart the workout, simply resume pedaling.

4. Follow your progress with the display.

See step 4 on page 14.

5. Measure your heart rate if desired.

See step 5 on page 15.

6. When you are finished exercising, the console will turn off automatically.

See step 6 on page 15.

HOW TO USE AN IFIT WORKOUT

1. Begin pedaling or press any button on the console to turn on the console.

A moment after you begin pedaling or press a button, a tone will sound, and the display will turn on.

2. Insert an iFit card and select a workout.

To use an iFit workout, insert an iFit card into the iFit slot; make sure that the iFit card is oriented so that the metal contacts are face down and are facing the slot. When the iFit card is properly inserted, the indicator next to the slot will turn on.

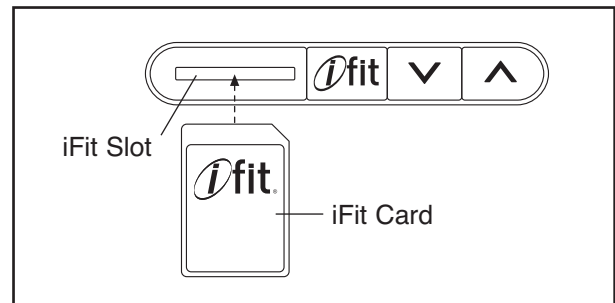

Next, select the desired workout on the iFit card by pressing the increase and decrease buttons next to the iFit slot.

A moment after you select a workout, the voice of a personal trainer will begin guiding you through your workout. iFit workouts function in the same way as preset workouts. To use the workout, see steps 3 to 6 on pages 15 and 16.

3. When you are finished exercising, remove the iFit card.

Remove the iFit card when you are finished exercising. Store the iFit card in a secure place.

HOW TO USE THE SOUND SYSTEM

To play music or audio books through the console sound system while you exercise, plug an audio cable (not included) into the jack on the console and into a jack on your MP3 player or CD player; **make sure that the audio cable is fully plugged in.**

Next, press the play button on your MP3 player or CD player. Adjust the volume level using the volume control on your MP3 player or CD player.

HOW TO CHANGE CONSOLE SETTINGS

The console features a user mode that allows you to select a unit of measurement and a backlight option for the console and to view console usage information.

1. Select the user mode.

To select the user mode, press and hold down the Priority Display button for a few seconds until the user mode information appears in the display.

2 Select a backlight option if desired.

The console has three backlight options. The ON option keeps the backlight on while the console is on. The AUTO option keeps the backlight on only while you are pedaling.

The OFF option turns the backlight off.

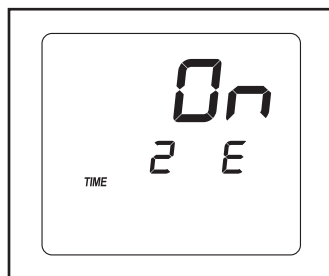

The upper display will show the currently selected backlight option. Press the Silent Magnetic Resistance increase button repeatedly to select the desired backlight option.

3. Select a unit of measurement if desired.

The console can show pedaling speed and distance in either miles or kilometers.

The lower right display will show the selected unit of measurement. An E for English miles or an M for metric kilometers will appear in the lower right display. To change the unit of measurement, press the Silent Magnetic Resistance decrease button repeatedly.

Note: When you replace the batteries, it may be necessary to reselect the unit of measurement.

4. View console usage information if desired.

The lower left display will show the total number of hours that the console has been used since the exercise bike was purchased.

5. Exit the user mode.

Press the Priority Display button to save the console settings and exit the user mode.

MAINTENANCE AND TROUBLESHOOTING

Inspect and tighten all parts of the exercise bike regularly. Replace any worn parts immediately.

To clean the exercise bike, use a damp cloth and a small amount of mild soap. **IMPORTANT: To avoid damage to the console, keep liquids away from the console and keep the console out of direct sunlight.**

CONSOLE TROUBLESHOOTING

If the console display becomes dim, or if the audio from the sound system stops intermittently, replace all the batteries at the same time; most console problems are the result of low batteries. See assembly step 5 on page 8 for replacement instructions.

Note: If you use the sound system regularly, it is recommended that you purchase an optional manufacturer-supplied power adapter (see assembly step 5 on page 8).

If the handgrip pulse sensor does not function properly, see step 5 on page 15.

HOW TO ADJUST THE REED SWITCH

If the console does not display correct feedback, the reed switch should be adjusted.

To adjust the reed switch, you must first remove the left pedal and the left front shield. Using an adjustable wrench, turn the left pedal clockwise and remove it.

Next, remove all the screws from the left and right front shields; **there are two sizes of screws in the front shields—note which size of screw you remove from each hole.** Then, gently pull the left front shield away from the frame.

Locate the Reed Switch (46). Turn the Pulley (29) until a Magnet (30) is aligned with the Reed Switch. Next, loosen, but do not remove, the indicated M4 x 16mm Screw (57).

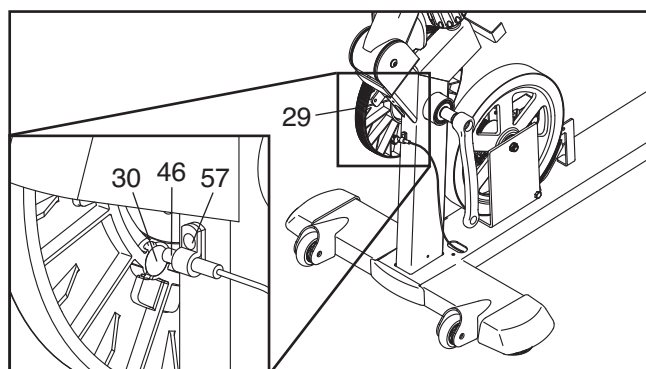

Slide the Reed Switch (46) slightly closer to or away from the Magnet (30), and then retighten the M4 x 16mm Screw (57). Turn the Pulley (29) for a moment.

Repeat these actions until the console displays correct feedback. When the reed switch is correctly adjusted, reattach the front shields and the left pedal.

HOW TO ADJUST THE BELT

If the pedals slip while you are pedaling, even while the resistance is adjusted to the highest setting, the belt may need to be adjusted.

To adjust the belt, you must first remove the right pedal and the right front shield. Using an adjustable wrench, turn the right pedal counterclockwise and remove it.

Next, remove all the screws from the left and right front shields; **there are two sizes of screws in the front shields—note which size of screw you remove from each hole.** Then, gently pull the right front shield away from the frame.

Next, loosen the M6 x 20mm Hex Screw (88). Then, tighten the M10 x 50mm Hex Screw (70) until the Drive Belt (47) is tight.

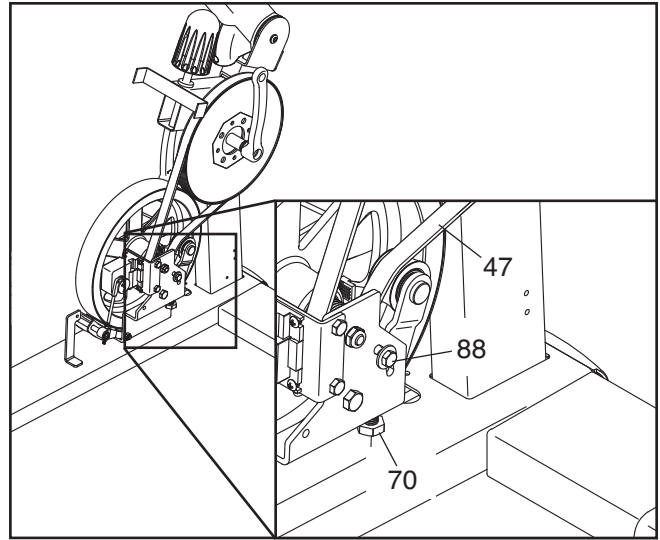

When the Drive Belt (47) is tight, tighten the M6 x 20mm Hex Screw (88).

Then, reattach the front shields and the right pedal.

FCC INFORMATION

This equipment has been tested and found to comply with the limits for a Class B digital device, pursuant to part 15 of the FCC Rules. These limits are designed to provide reasonable protection against harmful interference in a residential installation. This equipment generates, uses, and can radiate radio frequency energy and, if not installed and used in accordance with the instructions, may cause harmful interference to radio communications. However, there is no guarantee that interference will not occur in a particular installation. If this equipment does cause harmful interference to radio or television reception, which can be determined by turning the equipment off and on, the user is encouraged to try to correct the interference by one or more of the following measures:

- Reorient or relocate the receiving antenna.
- Increase the separation between the equipment and the receiver.
- Connect the equipment into an outlet on a circuit different from that to which the receiver is connected.
- Consult the dealer or an experienced radio/TV technician for help.

WARNING: Per FCC rules, changes or modifications not expressly approved by ICON could void the user's authority to operate the equipment.

EXERCISE GUIDELINES

⚠ WARNING: Before beginning this or any exercise program, consult your physician. This is especially important for persons over the age of 35 or persons with pre-existing health problems.

The pulse sensor is not a medical device. Various factors may affect the accuracy of heart rate readings. The pulse sensor is intended only as an exercise aid in determining heart rate trends in general.

These guidelines will help you to plan your exercise program. For detailed exercise information, obtain a reputable book or consult your physician. Remember, proper nutrition and adequate rest are essential for successful results.

EXERCISE INTENSITY

Whether your goal is to burn fat or to strengthen your cardiovascular system, exercising at the proper intensity is the key to achieving results. You can use your heart rate as a guide to find the proper intensity level. The chart below shows recommended heart rates for fat burning and aerobic exercise.

165	155	145	140	130	125	115	♥♥
145	138	130	125	118	110	103	♥
125	120	115	110	105	95	90	♥
<hr/>							
20	30	40	50	60	70	80	

To find the proper intensity level, find your age at the bottom of the chart (ages are rounded off to the nearest ten years). The three numbers listed above your age define your “training zone.” The lowest number is the heart rate for fat burning, the middle number is the heart rate for maximum fat burning, and the highest number is the heart rate for aerobic exercise.

Burning Fat—To burn fat effectively, you must exercise at a low intensity level for a sustained period of time. During the first few minutes of exercise, your body uses *carbohydrate calories* for energy. Only after the first few minutes of exercise does your body begin to use stored *fat calories* for energy. If your goal is to burn fat, adjust the intensity of your exercise until your heart rate is near the lowest number in your training zone. For maximum fat burning, exercise with your heart rate near the middle number in your training zone.

Aerobic Exercise—If your goal is to strengthen your cardiovascular system, you must perform aerobic exercise, which is activity that requires large amounts of oxygen for prolonged periods of time. For aerobic exercise, adjust the intensity of your exercise until your heart rate is near the highest number in your training zone.

WORKOUT GUIDELINES

Warming Up—Start with 5 to 10 minutes of stretching and light exercise. A warm-up increases your body temperature, heart rate, and circulation in preparation for exercise.

Training Zone Exercise—Exercise for 20 to 30 minutes with your heart rate in your training zone. (During the first few weeks of your exercise program, do not keep your heart rate in your training zone for longer than 20 minutes.) Breathe regularly and deeply as you exercise—never hold your breath.

Cooling Down—Finish with 5 to 10 minutes of stretching. Stretching increases the flexibility of your muscles and helps to prevent post-exercise problems.

EXERCISE FREQUENCY

To maintain or improve your condition, complete three workouts each week, with at least one day of rest between workouts. After a few months of regular exercise, you may complete up to five workouts each week, if desired. Remember, the key to success is to make exercise a regular and enjoyable part of your everyday life.

SUGGESTED STRETCHES

The correct form for several basic stretches is shown at the right. Move slowly as you stretch—never bounce.

1. Toe Touch Stretch

Stand with your knees bent slightly and slowly bend forward from your hips. Allow your back and shoulders to relax as you reach down toward your toes as far as possible. Hold for 15 counts, then relax. Repeat 3 times. Stretches: Hamstrings, back of knees and back.

2. Hamstring Stretch

Sit with one leg extended. Bring the sole of the opposite foot toward you and rest it against the inner thigh of your extended leg. Reach toward your toes as far as possible. Hold for 15 counts, then relax. Repeat 3 times for each leg. Stretches: Hamstrings, lower back and groin.

3. Calf/Achilles Stretch

With one leg in front of the other, reach forward and place your hands against a wall. Keep your back leg straight and your back foot flat on the floor. Bend your front leg, lean forward and move your hips toward the wall. Hold for 15 counts, then relax. Repeat 3 times for each leg. To cause further stretching of the achilles tendons, bend your back leg as well. Stretches: Calves, achilles tendons and ankles.

4. Quadriceps Stretch

With one hand against a wall for balance, reach back and grasp one foot with your other hand. Bring your heel as close to your buttocks as possible. Hold for 15 counts, then relax. Repeat 3 times for each leg. Stretches: Quadriceps and hip muscles.

5. Inner Thigh Stretch

Sit with the soles of your feet together and your knees outward. Pull your feet toward your groin area as far as possible. Hold for 15 counts, then relax. Repeat 3 times. Stretches: Quadriceps and hip muscles.

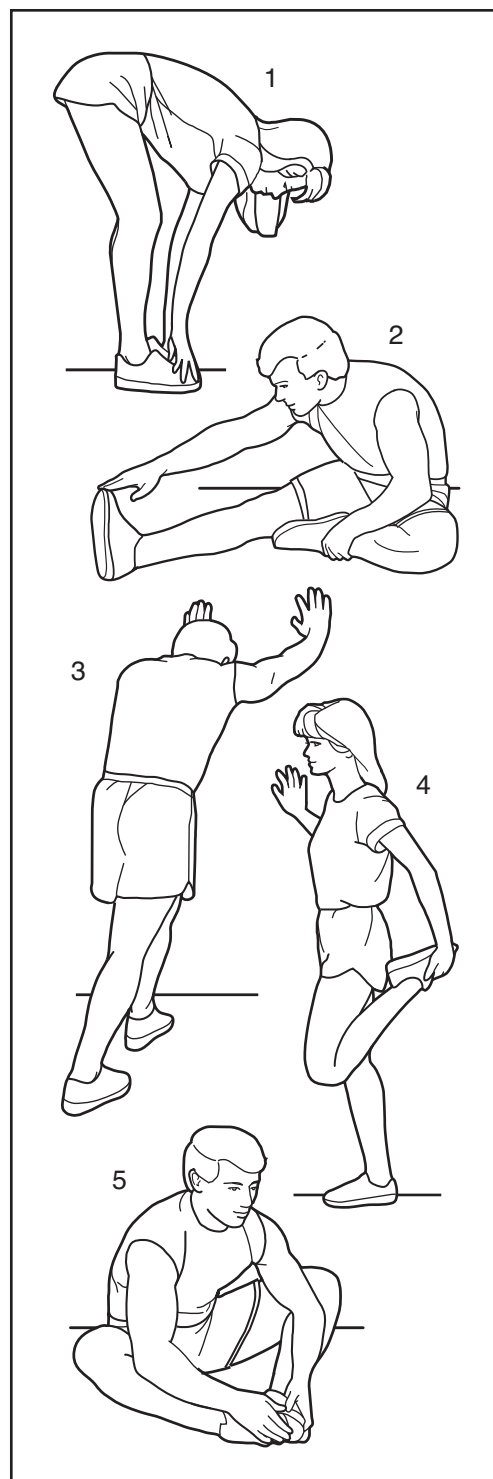

NOTES

PART LIST

Model No. PFEX63910.1 R0112A

Key No.	Qty.	Description	Key No.	Qty.	Description
1	1	Frame	46	1	Reed Switch/Wire
2	1	Upright	47	1	Drive Belt
3	1	Seat Carriage	48	2	Rear Stabilizer Cap
4	1	Console	49	1	Seat Handle
5	2	Crank Cover	50	2	Flange Screw
6	2	Accent Ring	51	2	M6 x 42mm Patch Screw
7	1	Upright Knob	52	4	M8 x 55mm Patch Screw
8	1	Backrest	53	4	M6 Locknut
9	1	Seat	54	6	M8 x 16mm Patch Screw
10	2	Pulse Grip	55	10	M8 Split Washer
11	1	Seat Handlebar	56	2	Bumper
12	2	Brake Pad Spacer	57	17	M4 x 16mm Screw
13	1	Left Front Shield	58	1	Pulse Wire
14	1	Right Front Shield	59	1	Right Handlebar
15	1	Left Front Stabilizer	60	1	Left Handlebar
16	1	Rear Stabilizer	61	6	M8 Locknut
17	2	Wheel	62	1	M10 x 63mm Bolt Set
18	2	Upper Roller	63	4	Wheel Bushing
19	2	Leveling Foot	64	2	M10 Locknut
20	2	Upright Bushing	65	1	Frame Cover
21	1	Right Pedal/Strap	66	2	Front Stabilizer Cap
22	1	Left Pedal/Strap	67	4	M10 x 40mm Patch Screw
23	1	Right Crank	68	1	Upright Cover
24	1	Left Crank	69	2	M8 x 48mm Button Bolt
25	1	Seat Lock Bracket	70	1	M10 x 50mm Hex Screw
26	1	Left Shield	71	2	Lower Roller
27	1	Right Shield	72	4	M8 x 38mm Button Bolt
28	1	Large Snap Ring	73	4	M6 x 20mm Button Bolt
29	1	Pulley	74	1	Water Bottle Holder
30	2	Magnet	75	4	Roller Axle
31	1	Spindle	76	5	M6 x 9mm Patch Screw
32	1	Steel Washer	77	10	M6 x 18mm Patch Screw
33	2	Crank Bearing	78	2	M10 x 32mm Button Bolt
34	1	Flywheel	79	1	Pulse Receptacle/Extension Wire
35	1	Flywheel Axle	80	4	M4 x 16mm Flange Screw
36	2	Seat Carriage Cap	81	4	M6 x 38mm Patch Screw
37	4	Handlebar Cap	82	1	M4 x 12mm Screw
38	2	M8 Jam Nut	83	1	Frame Cap
39	1	Idler	84	5	M4 x 19mm Screw
40	1	Right Front Stabilizer	85	2	Spindle Cover
41	1	Seat Lock	86	1	Rail
42	1	Brake Pad	87	1	M6 x 15mm Shoulder Screw
43	1	Main Wire Harness	88	1	M6 x 20mm Hex Screw
44	12	M6 Washer	89	1	M6 Washer
45	1	Clamp	90	1	Motor Bracket

Key No.	Qty.	Description	Key No.	Qty.	Description
91	1	Resistance Motor	99	1	Resistance Bracket
92	4	M4 x 12mm Flange Screw	100	1	M5 Washer
93	2	M6 x 8mm Hex Screw	101	1	M5 x 7mm Screw
94	1	M6 x 65mm Hex Bolt	102	1	M6 Locknut
95	1	Resistance Magnet	103	1	Small Snap Ring
96	1	Resistance Arm	104	2	Adjustment Nut
97	1	Motor Disc	*	–	Assembly Tool
98	1	M3.5 x 12mm Screw	*	–	User's Manual

Note: Specifications are subject to change without notice. For information about ordering replacement parts, see the back cover of this manual. *These parts are not illustrated.

EXPLODED DRAWING A

Model No. PFE63910.1 R0112A

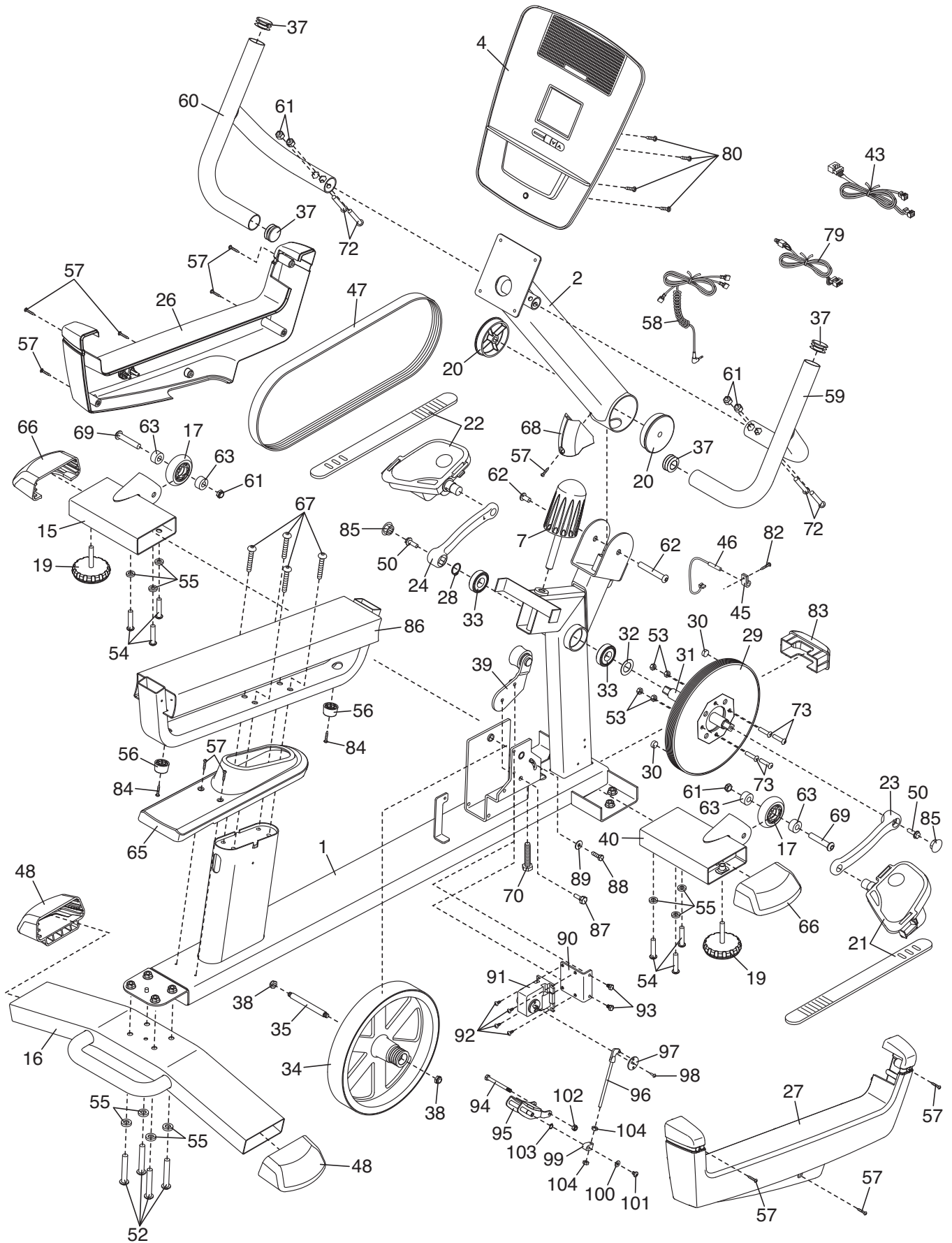

EXPLODED DRAWING B

Model No. PFEX63910.1 R0112A

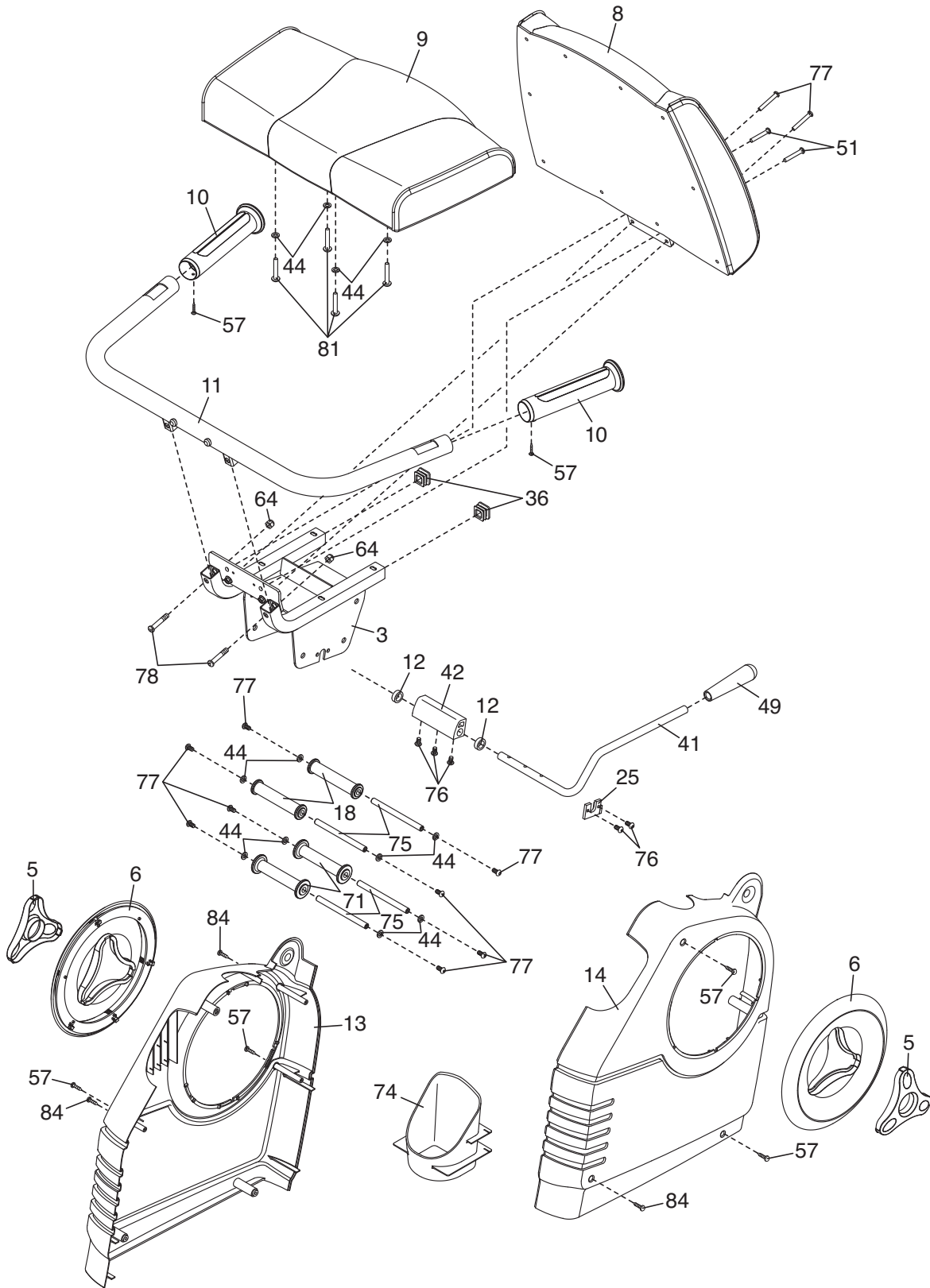

ORDERING REPLACEMENT PARTS

To order replacement parts, see the front cover of this manual. To help us assist you, please be prepared to provide the following information when contacting us:

- the model number and serial number of the product (see the front cover of this manual)
- the name of the product (see the front cover of this manual)
- the key number and description of the replacement part(s) (see the PART LIST and the EXPLODED DRAWING near the end of this manual)

LIMITED WARRANTY

IMPORTANT: You must register this product within 30 days of the purchase date to avoid added fees for service needed under warranty. Go to www.proformservice.com/registration.

ICON Health & Fitness, Inc. (ICON) warrants this product to be free from defects in workmanship and material, under normal use and service conditions. The frame is warranted for seven (7) years. Parts and labor are warranted for ninety (90) days from the date of purchase.

This warranty extends only to the original purchaser. ICON's obligation under this warranty is limited to repairing or replacing, at ICON's option, the product through one of its authorized service centers. All repairs for which warranty claims are made must be preauthorized by ICON. If the product is shipped to a service center, freight charges to and from the service center will be the customer's responsibility. For replacement parts shipped while the product is under warranty, the customer will be responsible for a minimal handling charge. For in-home service, the customer will be responsible for a minimal trip charge. This warranty does not extend to any damage to a product caused by or attributable to freight damage, abuse, misuse, improper or abnormal usage, or repairs not provided by an ICON authorized service center; to products used for commercial or rental purposes or as store display models; or to products transported or purchased outside the US. No other warranty beyond that specifically set forth above is authorized by ICON.

ICON is not responsible or liable for indirect, special, or consequential damages arising out of or in connection with the use or performance of the product; damages with respect to any economic loss, loss of property, loss of revenues or profits, loss of enjoyment or use, or costs of removal or installation; or other consequential damages of whatsoever nature. Some states do not allow the exclusion or limitation of incidental or consequential damages. Accordingly, the above limitation may not apply to you.

The warranty extended hereunder is in lieu of any and all other warranties, and any implied warranties of merchantability or fitness for a particular purpose are limited in their scope and duration to the terms set forth herein. Some states do not allow limitations on how long an implied warranty lasts. Accordingly, the above limitation may not apply to you.

This warranty gives you specific legal rights. You may also have other rights that vary from state to state.

ICON Health & Fitness, Inc., 1500 S. 1000 W., Logan, UT 84321-9813