

USER'S MANUAL  
Rev. 03/2006

# CD3200 THYRISTOR UNIT

from 15A to 110A



## CD Automation S.r.l.

Via Picasso 34/36 - 20025 - Legnano (MI) - ITALY

Tel +39 0331 577479 - Fax +39 0331 579479

E-Mail: [info@cdautomation.com](mailto:info@cdautomation.com) - WEB: [www.cdautomation.com](http://www.cdautomation.com)



# INDEX

<b>1 Warnings .....</b>	<b>5</b>
1.1 Important warning for safety	5
<b>2 Introduction .....</b>	<b>7</b>
2.1 Advantages compared with analog thyristor unit.	7
2.2 CD-KP high lights	8
2.3 Clone facility using CD-EASY	9
2.4 Software Configurator	10
<b>3 Quick Start .....</b>	<b>11</b>
<b>4 CD3200 Sizing .....</b>	<b>11</b>
<b>5 Identification and Product Code .....</b>	<b>12</b>
5.1 Identification of the unit	12
5.2 Ordering code	13
<b>6 Installation .....</b>	<b>14</b>
6.1 Environmental installation conditions	14
6.2 Dimensions	15
6.3 CT dimensions	15
6.4 Fixing holes	16
6.5 Removing the cover	16
<b>7 Wiring instructions .....</b>	<b>17</b>
7.1 Wiring details	17
7.2 Power Terminals	19
7.3 Auxiliary Terminals	19
7.4 Diagram of control connection from size 15A to 25A	20
7.5 Diagram of control connection from size 35A to 45A	21
7.6 Diagram of control connection from size 60A to 90A	22
7.7 Diagram of control connection for size 110A	23
<b>8 Technical features .....</b>	<b>24</b>
8.1 Power output features	24
8.2 Derating curve	24
8.3 Cooling fans	24
<b>9 Led status and alarms.....</b>	<b>25</b>
9.1 LED Status Table	25
9.2 Events and alerts that don't stop CD3200	25
9.3 Heater break alarm and scr short circuit (HB Option)	25
<b>10 Types of firing mode.....</b>	<b>27</b>
10.1 Soft Start + Phase Angle (S+PA)	27
10.2 Phase Angle (PA)	27
10.3 Feed-back ( control mode )	29

---

<b>11 Connection description .....</b>	<b>30</b>
11.1 Electronic boards	30
11.2 Auxiliary power supply connections	31
11.3 Analog inputs	32
11.4 Digital Input	35
11.5 RS485 serial connection	36
11.6 PG Connector	36
11.7 Address configuration	37
<b>12 Fuses and Fuse holder .....</b>	<b>38</b>
12.1 Fuses and Fuse Code for UL	38
12.2 Fuses and Fuse Code for CE	39
12.3 FuseHolder size	40
<b>13 Modbus communication .....</b>	<b>41</b>
13.1 Physical requirements	41
13.2 Modbus Rtu Protocol	41
13.3 Message formats	41
13.4 Read holding registers (read n words) – Function 03	44
13.5 Preset multiple registers (write n words) - Function 16	44
13.6 Error and exception responses	45
13.7 Modbus parameters	46
<b>14 Maintenance .....</b>	<b>50</b>
14.1 Trouble Shooting	50
14.2 Fans	51
14.3 Servicing	51
14.4 Repairing procedure	51
14.5 Warranty condition	51
<b>15 CD Automation's distributors.....</b>	<b>52</b>
<b>16 Note .....</b>	<b>54</b>

# 1 Warnings

## 1.1 Important warning for safety

This chapter contains instructions about safety. The non-observation of these warnings can cause serious accidents and the loss of life of the operator. Serious damages can also be caused to the thyristor unit and to the component system in which it is included.

The installation must be done by qualified people.

In the manual description are used the following icons.



**Hazard:** This icon is present in all operative procedures where, if not executed properly, can cause serious accidents and loss of life of the operator.



**Attention:** This icon is present in all operative procedures where, if not executed properly, can cause faults to the thyristor unit.



Thyristor units are used in power industrial equipment. When the thyristor unit is working there are on the unit the following voltages.

- Maximum main supply voltage on power terminals up to 600 V.
- Auxiliary supply up to 690 Vac (see order code)
- Fan voltage 230Vac 50/60Hz (110V optional)

Don't remove the cover which provides adequate protection against electric shock. Don't use this thyristor unit in aerospace and nuclear applications.



### **Electric Shock Hazard (Risque the choque électrique)**

When the thyristor unit has been connected to main supply voltage and is switched off, before touching it be sure that the unit is isolated and wait at least one minute to allow discharging internal capacitors. Thus be sure that:

- access to the thyristor unit is only permitted to specialized personnel;
- the authorized personnel must read this manual before having access to the unit;
- the access to the units must be denied to unauthorized personnel.



### **Important warnings(attention)**

Local regulations regarding electrical installation should be rigidly observed.

- Safety regulations must be rigidly observed.
- Don't bend components to maintain insulation distances.
- Protect the units from high temperature humidity and vibrations (see performances).
- Don't touch components to prevent electrostatic discharges on them.
- Verify that all ratings are in line with real needs.
- If authorized personnel must measure voltage current etc. on units, take away rings and other jewels from fingers and hands.
- Authorized personnel working on the thyristor unit under power supply voltage must work on insulated board. Be sure that the board is not connected to earth.

This listing does not represent a complete enumeration of all necessary safety cautions.

**Protection(Protection)**

CD3200 thyristor unit has an insulated cover to compliance to International specification IP20. To understand if IP20 protection is sufficient should be evaluated the installation place where the units are installed

**Earth(terre)**

CD3200 family has isolated heatsink. For safety connect the heatsink to earth to avoid shocks in case that circuit board or THYRISTOR lose insulation. Earth impedance should be correspondent to local earth regulation. Periodically the earth efficiency should be inspected.

**Electronic supply (alimentation électronique)**

CD3000 family electronic circuit should be supplied by dedicated voltage supply for all electronic circuit but not in parallel with contactor's coil, solenoids and other inductive or capacitive loads. It's recommended to use a shielded transformer.

**Electromagnetic compatibility (compatibilité électromagnétique)**

Our thyristor units have an excellent immunity to electromagnetic interferences if all suggestions contained in this manual are respected. In respect to a good Engineering practice, all inductive loads like solenoids contactor coils should have a filter in parallel.

**Emissions (emission)**

All thyristor switching at high speed generate some radiofrequency disturbance. CD3200 series compliance with EMC rules for CE mark. In many installations near electronic devices have not been noted problems. If radiofrequency devices at low frequency are used near the thyristor unit some precautions should be taken like line Filters and shielded cables for input signal and for load cables.

**NOTES**

We reserves the right to apply modifications to the our products without any advice.



The thyristor unit must be mounted vertically and with no obstruction above and below to allow good flow ventilation.

When mounted side by side leave a gap of 15 mm between the units.  
Hot air of one thyristor unit must not invest the unit positioned above.  
The maximum cabinet temperature must not exceed 40°C.



A suitable electromechanical device must ensure that the unit can be electrically isolated from the incoming line supply.



## 2 Introduction

A thyristor unit is semiconductor device which acts as a switch formed by two thyristors in antiparallel. To switch on the alternating current the input signal will be on and the thyristor will switch off at first Zero Crossing voltage with no input signal. The benefits of thyristor units compared with electromechanical contactors are numerous: no moving parts, no maintenance and capacity to switch very fast. Thyristors are the only solution to control transformers and special loads that change resistance with temperature and with age.

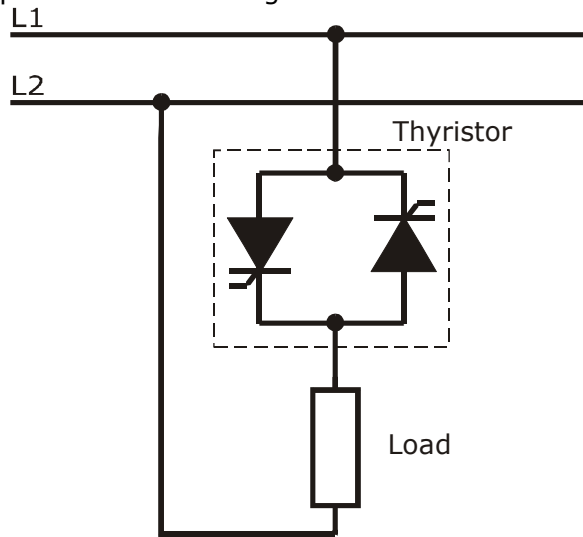

### 2.1 Advantages compared with analog thyristor unit.

CD3200 can be connected via RS485 to an Industrial Personal Computer. On serial link are available many information like: current, power, load status and all the parameters for diagnostic and configuration. Tele service and clone facility is also available. The advantages over the analog and non "Full digital" versions are flexibility and the possibility to implement special features without to change any Hardware. Several strategies can be implemented and selected via the parameter on serial link. All these features are not available on analog thyristor unit that use also small micro just to perform dedicated task (Ex. for Heater Break Alarm).



On CD Automation web-site is available, free of charge, the Configuration Software.

A cable with its built in converter and connector is available from CD Automation.

The configuration cable can be plugged into the PG connector of CD3200, or if a CD-KP is available it's possible to have the connection above indicated on front unit.

This solution allow to engineers to verify configuration without to go inside the cubicle where there is high voltage and without to stop the plant.

## 2.2 CD-KP high lights

### 2.2.1 General description

- Local/remote facility
- Set point ramp up/down
- Scroll selection of:
  - Set point power
  - Power read out
  - Current
- Display indication for:
  - Heater Break Alarm
  - SCR short circuit
- Retransmission (4-20mA or 0-10V selectable) of one of these parameters: power, current.
- Dimensions 48x96x92mm (WxHxD)



CD-KP is designed to give two access levels.

- First Level Access: the operator is able to view the power, current and voltage as well as set the power when the CD-KP is in Local Mode. At this level the password function is disabled to prevent accidental parameter changes by unauthorized personnel.
- Second level access: By connecting a PC to the RS232 port, located on the front of the CD-KP, it's possible to have access to all parameters of the CD Automation Thyristor Unit using the free downloadable Configuration Software. Configuration changes can be made interactively, without powering down the unit, removing the need to open the cabinet or to stop the process.



## 2.3 Clone facility using CD-EASY

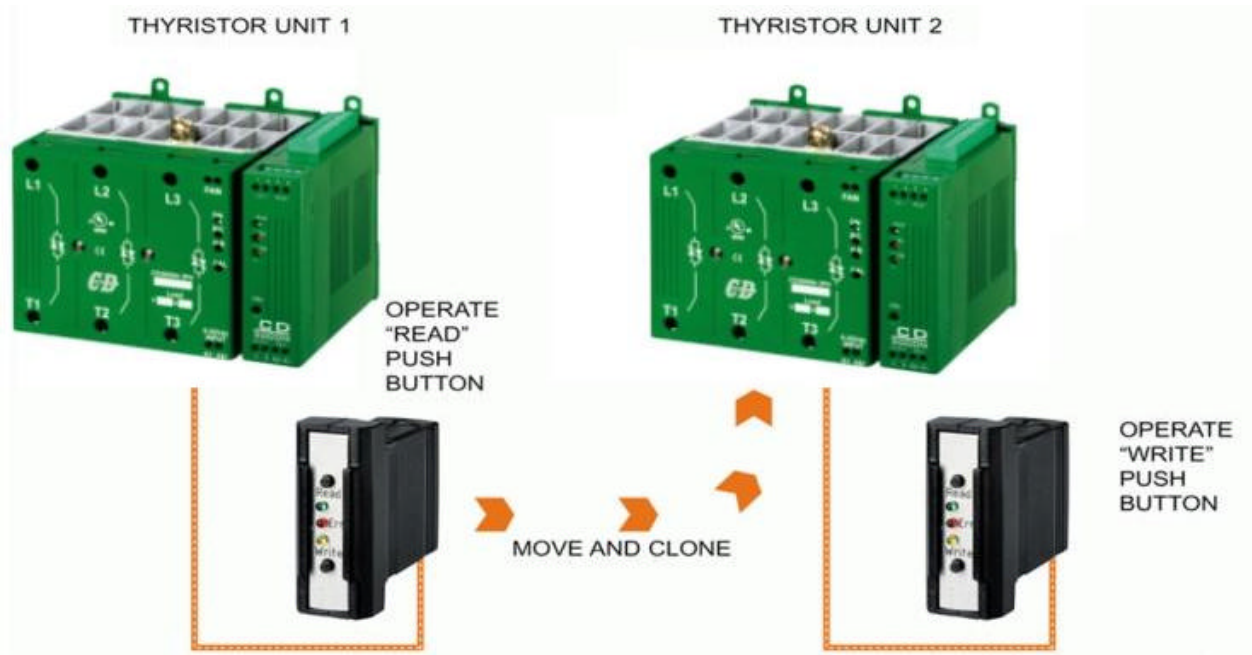

CD-EASY is a Memory Support used by maintenance personnel in the shop floor. The Clone Facility makes it possible to copy the configuration of one Thyristor Unit and paste it into another in a matter of seconds. The CD-EASY can be loaded with the standard unit operating configuration and stored together with the system drawings in a convenient place, enabling unit reconfiguration within seconds if required.

For CD-KP and CD-EASY are available Maintenance Manuals on [www.cdautomation.com](http://www.cdautomation.com).

## 2.4 Software Configurator

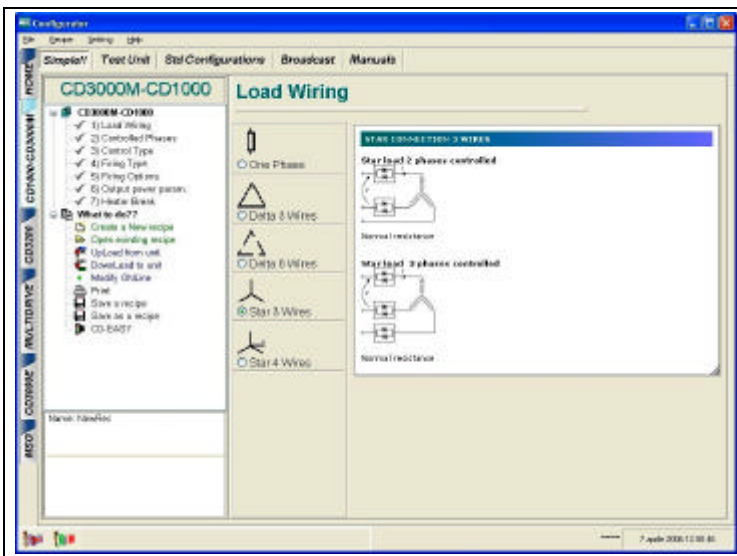

You can download the free software Configurator from our web site.  
[www.cdautomation.com](http://www.cdautomation.com)

If the CD3200 code is in line with your requirement, providing that the operating voltage and Load current are inside the code the CD3200 has been already configured in our Factory and you are ready to run.

You need software tools only to modify the ordered configuration. Anyway we suggest checking the unit on the machine with the test section.

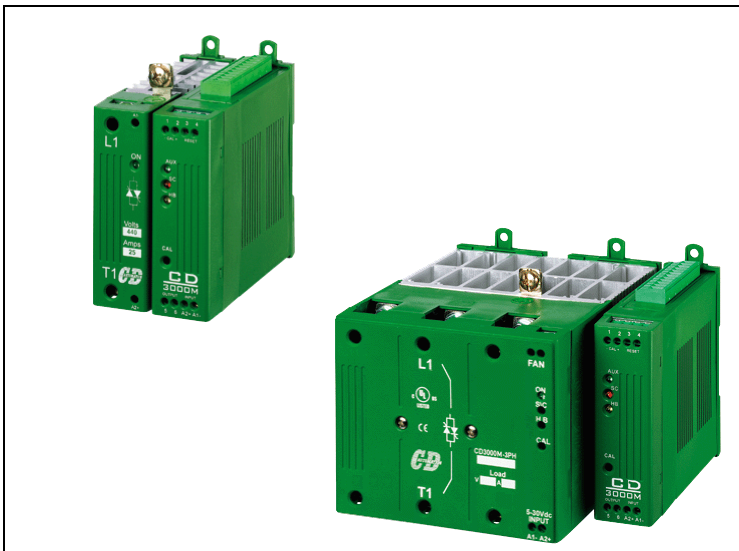

To install the software download it from the website, launch the installation program and follow the instruction on the screen.

To configure the unit you can use the standard communication port RS485 on terminals blocks or use the programming Cable and plug it inside the PG connector. (see par. 11.6)



Connect the other side of the programming cable to the PC RS232(9PIN) serial port.

Set the baud (=9600) and address (default=1) of PC serial port.

## 3 Quick Start



**Attention:** this procedure must be carried out by skilled people only.

If your CD3200 code is in line with what you really need, then the main configuration is already done by CD Automation and you just need to do the following steps:

1. Verify CD3200's current sizing. Be sure that:
    - the load current is equal or less than the nominal one of CD3200
    - the main voltage is equal or less than the nominal voltage of CD3200
  2. Verify the Product code
  3. Verify the Installation
  4. Verify the Wiring:
    - all auxiliary connections must be done in line with wirings on this manual
    - verify that there isn't a short circuit on the load
    - verify that the Reset Contact on terminal 3 and 4 are closed
    - With External Enable option give Enable to the unit
  5. Supply the auxiliary voltage of the unit
  6. Supply the Fan at 230VAC  $\pm 15\%$  50/60Hz (110VAC  $\pm 15\%$  50/60Hz Optional) (Only for size 110A)
  7. Supply the Power unit
1. Makes Calibration procedure (see par. 10.2.2)

**If your CD3200 code is NOT in line with what you really need, use the configurator software tool to set-up the unit.**

## 4 CD3200 Sizing

### 4.1.1 Wiring with resistive load

$$I = \frac{P}{V}$$

V = Nominal voltage phase to phase

I = CD3200 Nominal current

P = Nominal power to the load

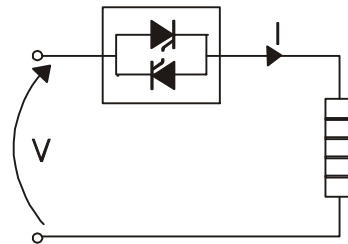

### 4.1.2 Wiring with inductive load

$$I = \frac{P}{V \cos \phi}$$

V = Nominal voltage phase to phase

I = CD3200 Nominal current

P = Nominal power to the load

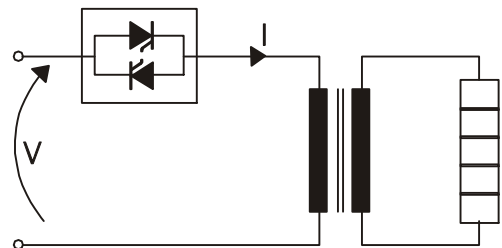

## 5 Identification and Product Code

### 5.1 Identification of the unit



Before to install the CD3200 unit examine for damages or deficiencies. If any is found, notify the carrier immediately. Check that the product features shown on CD3200 identification label corresponds to that ordered (see par.5.2)

An identification label provides all the information regarding the factory settings of the unit. This label is on the unit, as represented below:

Identification Label

INPUT	AUX	F.BACK	OPTION	FIRING
<input type="checkbox"/> 0-10V	<input type="checkbox"/> 230V	<input type="checkbox"/> V	<input type="checkbox"/> HB	<input type="checkbox"/> Soft Start
<input type="checkbox"/> 4-20mA	<input type="checkbox"/> 480V	<input type="checkbox"/> V2	<input type="checkbox"/> NO.CL	
<input type="checkbox"/> POT	<input type="checkbox"/> 600V	<input type="checkbox"/> VxI	<input type="checkbox"/> CL.EXT	
<input type="checkbox"/> _____	<input type="checkbox"/> _____	<input type="checkbox"/> I	<input type="checkbox"/> EN.EXT	CD3200



## 5.2 Ordering code

Model CD3200

CD3200	1	2	3	4	5	6	7	8	9
Ex:CD3200	75A	75A	400V	480V	90:130V	0÷10V	PA	V	HB

1	Max CURRENT of CD3200								
15A 25A		35A 45A		60A 90A		110A			
The Max CURRENT must be equal or more than nominal current									

2	Load CURRENT
Specify this value that will be used to configure the unit in CD Automation	

3	Load Voltage(incoming voltage supply)
Specify this value that will be used to configure the unit in CD Automation	

4	Max VOLTAGE of CD3200		
480V		600V	
The Max VOLTAGE must be equal or more than operating voltage			

5	Auxiliary Voltage	
90:130V	Da	90 a 130Vac; 10VA
170:265V	Da	170 a 265Vac; 10VA
230:345V	Da	230 a 345Vac; 10VA
300:530V	Da	300 a 530Vac; 10VA
510:690V	Da	510 a 690Vac; 10VA

6	Input		
0÷10V 4÷20mA	0÷10Vdc 4÷20mA	POT	10KΩ potentiometer

7	Firing
S+PA PA	Soft Start + Phase Angle Phase Angle

8	Feed Back		
V I	Voltage Current	V2 VxI	Voltage square Power (VxI)

9	Options
COMM	MODBUS protocol in RS485 is standard
CD-KP	External Keypad
EF	External fuses and fuse holders
NF	No fuses
NCL	No current limit
CLP	External current limit profiling 0-10Vdc
EN	Opto isolated external enable
HB	Heater Break Alarm
FAN110	Fan voltage supply 110VAC ± 15% (std 230VAC ± 15%) 14W 50/60Hz
EP	External Protection IP20 for size S7C and S8C
CD-EASY	Clone facility & memory card
UL	UL Certification

## 6 Installation



*CD3200 unit should be always mounted in vertical position to improve air cooling on heatsink. Maintain minimum distances in vertical and in horizontal as below represented. Don't install in proximity of hot elements and near units generating electromagnetic interferences.*

When many units are mounted inside a cubicle provide air circulation as below represented. Sometimes it is necessary to provide a fan to have better air circulation.

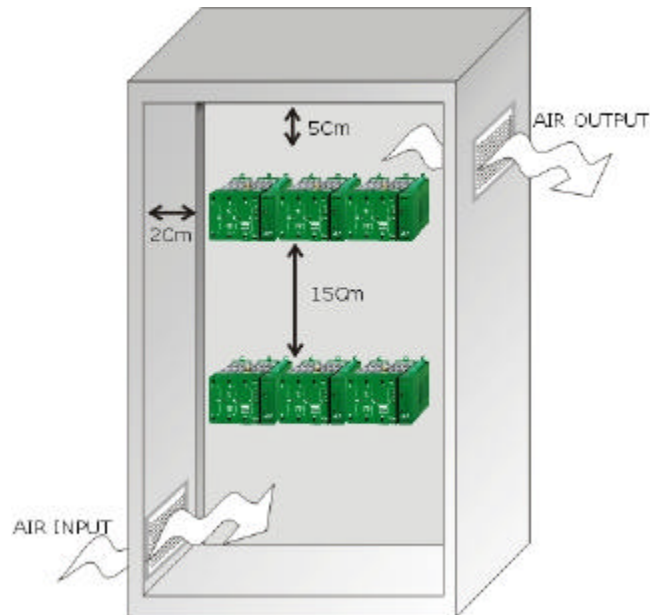

### 6.1 Environmental installation conditions

Ambient temperature	0-40°C at nominal current. Over 40°C use the derating curve (par.8.2)
Stocking temperature	-25°C to 70°C
Installation place	Don't install at direct sun light, where there are conductive dust, corrosive gas, vibration or water and also in salty environmental
Altitude	Up to 1000 meter over sea level. For higher altitude reduce the nominal current of 2% for each 100m over 1000m
Humidity	From 5 to 95% without condense and ice

## 6.2 Dimensions

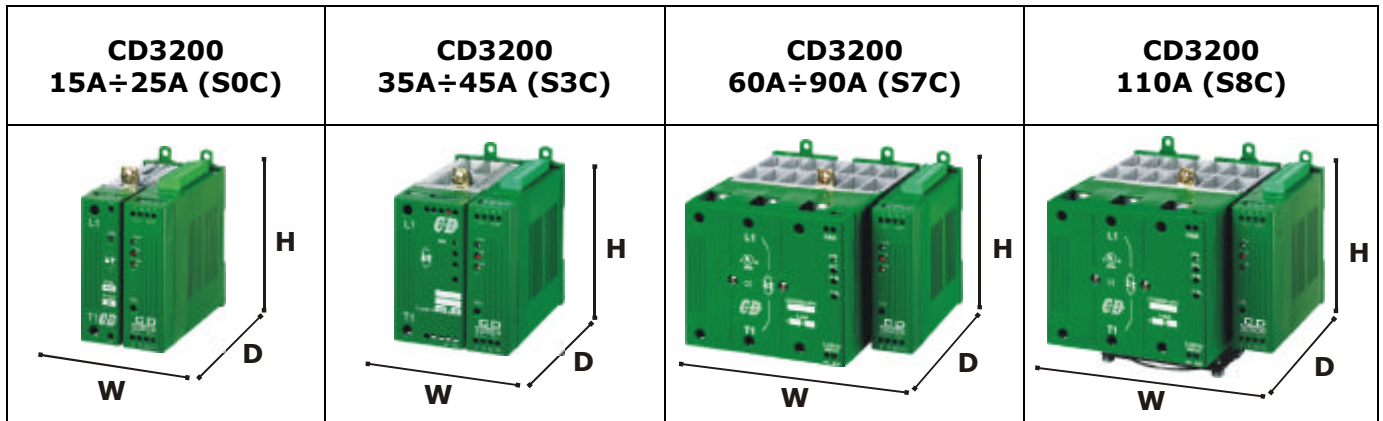

Size	W(mm)	H(mm)	D(mm)
15A (S0C)	63	120	120
25A (S0C)	63	120	120
35A (S3C)	85	120	120
45A (S3C)	85	120	120
60A (S7C)	148	120	159
90A (S7C)	148	120	159
110A (S8C)	148	138	159

## 6.3 CT dimensions

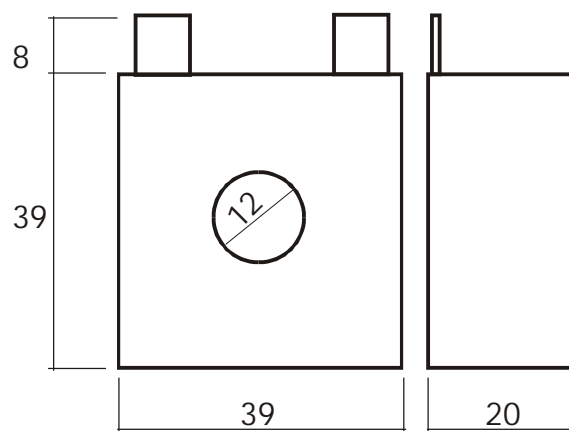

### 6.4 Fixing holes

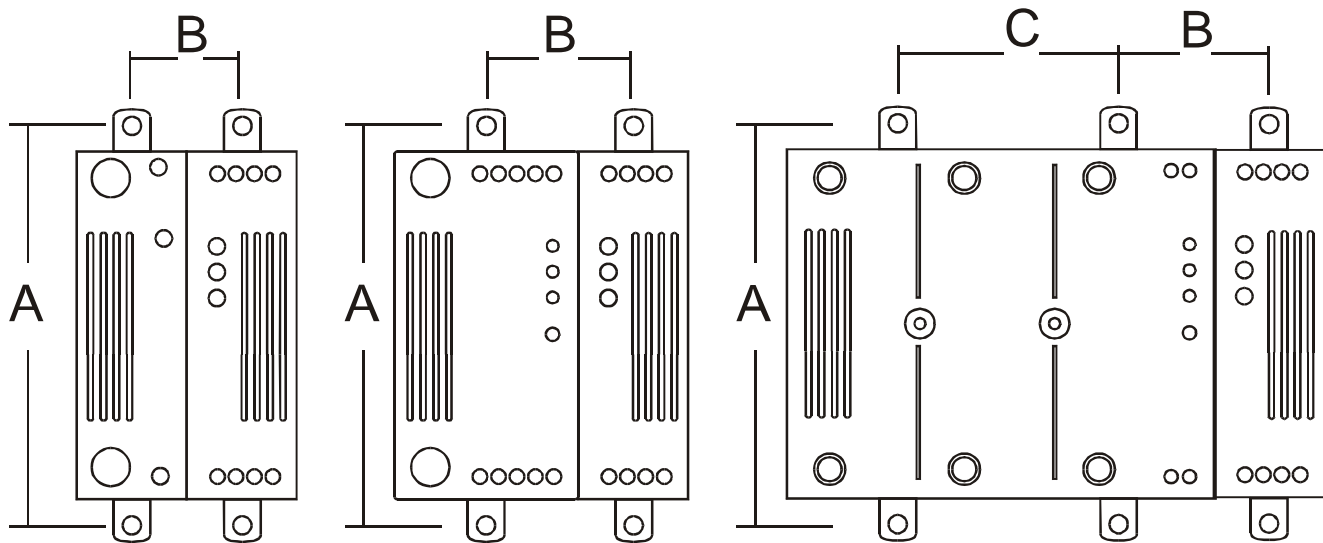

Size	A(mm)	B(mm)	C(mm)
15A (S0C)	110	30	-
25A (S0C)	110	30	-
35A (S3C)	110	40	-
45A (S3C)	110	40	-
60A (S7C)	110	40	65
90A (S7C)	110	40	65
110A (S8C)	110	40	65

### 6.5 Removing the cover

Remove plastic Cover For all size

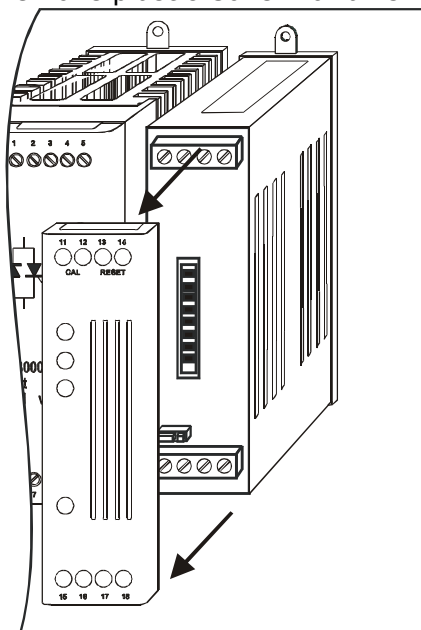

To remove the board Pull the PCB

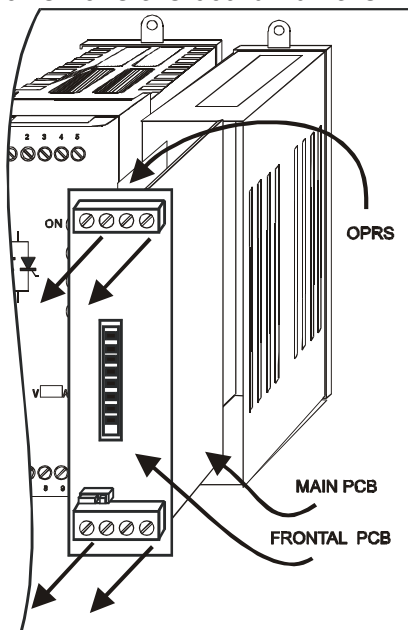



## 7 Wiring instructions



**Warning:** *this procedure can be done just by specialized personnel*  
*CD3200 unit has isolated heatsink. For safety connect the heatsink to hearth using its terminal with hearth symbol.*

CD3200 can be susceptible to airborne interferences from near equipment or from interferences on main supply, so a number of precautions must be taken.

- Contactors coils and chokes must have in parallel a RC filter and must be supplied with a different voltage line.
- All input/output signals must use screened bifilar wires.
- Signal input and output must not route in same cable try and must not be parallel.
- Local regulations regarding electrical installation should be rigidly observed.

### 7.1 Wiring details

Use copper cables and wires rated for use at 75 °C only, provided with the terminal type indicated below.

#### 7.1.1 Power cable torque (suggested)

Current	Connector Type	Torque Lb-in (N-m)	Wire Range AWG / kcmill	Wire Terminal
15A, 25A, 35A, 45A	M5 Screw	26.6 (3.0)	8	UL Listed (ZMVV) Wire Pin
60A, 90A, 110A	M6 Screw	70.8 (8.0)	1	UL Listed (ZMVV) Fork/Spade Terminal Copper Tube Crimp. Lug

**7.1.2 Power cable dimensions (suggested)**

Current	Supply			Load		
	Cable		Screw M	Cable		Screw M
	mm <sup>2</sup>	AWG		mm <sup>2</sup>	AWG	
15A	4	12	M5	4	12	M5
25A	6	10	M5	6	10	M5
35A	10	8	M5	10	8	M5
45A	10	8	M5	10	8	M5
60A	16	6	M6	16	6	M6
90A	35	3	M6	35	3	M6
110A	35	3	M6	35	3	M6

**7.1.3 Auxiliary cable dimensions (suggested)**

Current	Auxiliary Supply			Earth		
	Cable			Cable		Screw M
	mm <sup>2</sup>	AWG		mm <sup>2</sup>	AWG	
15A	0,50	18		4	12	M5
25A	0,50	18		6	10	M5
35A	0,50	18		6	10	M5
45A	0,50	18		6	10	M5
60A	0,50	18		6	10	M5
90A	0,50	18		6	10	M5
110A	0,50	18		6	10	M5

## 7.2 Power Terminals



*Before to connect or disconnect, make sure that power cables and auxiliary wires are insulated from live voltage.*

Terminal	Description
L1	Line Input Phase 1
T1	Load Output Phase 1

## 7.3 Auxiliary Terminals

### 7.3.1 Upper Terminal

Terminal	Description
1	(-) External Calibration 24 Vdc max
2	(+) External Calibration 24 Vdc max
3	Reset
4	Reset
5	(+) CD3200 Output Command signal (Internal Connections)
6	(-) CD3200 Output Command signal (Internal Connections)
A2+	(+) Input command signal 0÷10V,4÷20mA,POT
A1-	(-) Input command signal 0÷10V,4÷20mA,POT

### 7.3.2 Lateral Terminal

Terminal	Description
7	RS485 A
8	RS485 B
9	Output +8Vdc stabilized 1 mA MAX
10	HB relay contact (Max 500mA , 125Vac) Optional
11	HB relay contact (Max 500mA , 125Vac) Optional
12	External current limit profiling 0-10Vdc (see par.11.3.3)
13	Current Transformer (CT1) input
14	Current Transformer (CT1) input
15	not connected
16	Auxiliary supply voltage (see par.5.2)
17	Ground
18	Auxiliary supply voltage (see par.5.2)

## 7.4 Diagram of control connection from size 15A to 25A



**Warning:** this procedure can be done just by specialized personnel.

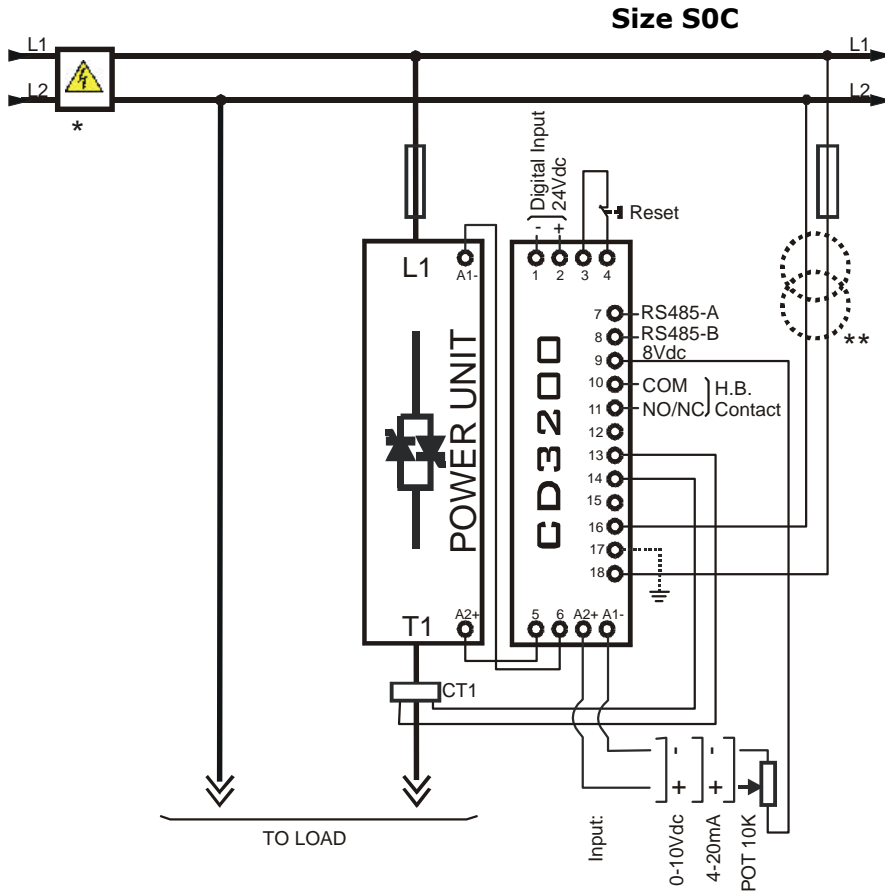

\* The user installation must be protected by electromagnetic circuit breaker or by fuse isolator

\*\* If the Auxiliary Voltage (written on the identification label) is different from Supply Voltage (to the load), use an external transformer as designated.

**NOTE:**

- To work, terminals 3-4 must be linked.
- The auxiliary voltage supply of Drive M unit must be synchronized with load voltage power supply (L2, L3).

**Load Type**

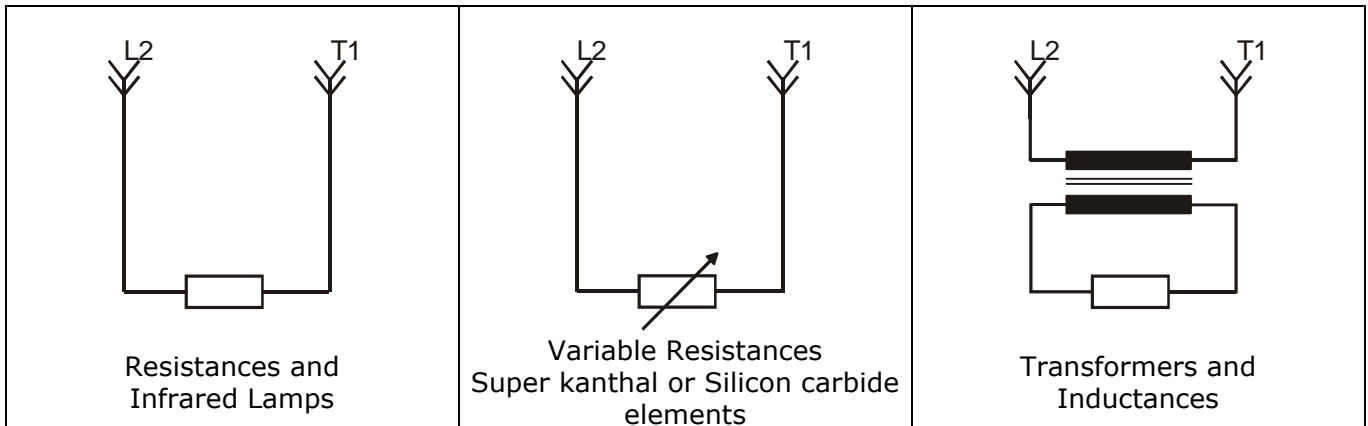

## 7.5 Diagram of control connection from size 35A to 45A



**Warning:** this procedure can be done just by specialized personnel.

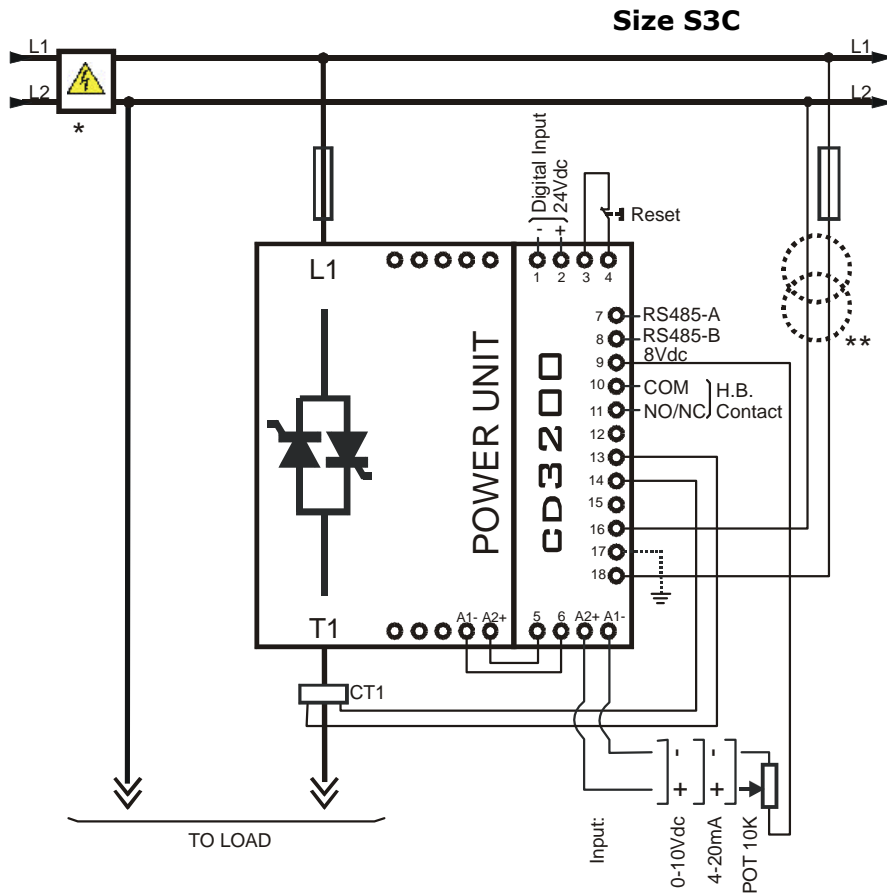

\* The user installation must be protected by electromagnetic circuit breaker or by fuse isolator

\*\* If the Auxiliary Voltage (written on the identification label) is different from Supply Voltage (to the load), use an external transformer as designated.

**NOTE:**

- To work, terminals 3-4 must be linked.
- The auxiliary voltage supply of Drive M unit must be synchronized with load voltage power supply (L2, L3).

**Load Type**

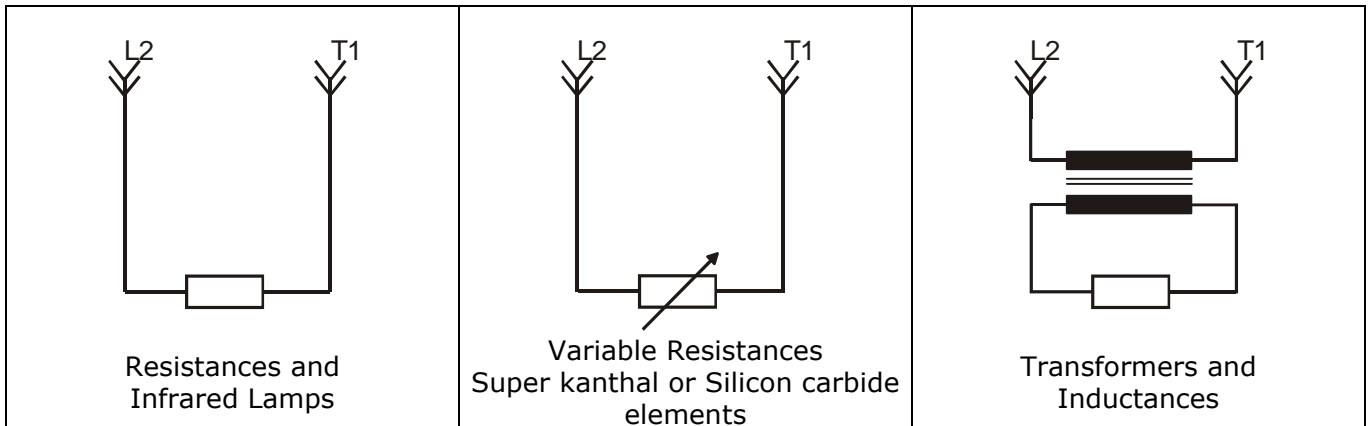

## 7.6 Diagram of control connection from size 60A to 90A



**Warning:** this procedure can be done just by specialized personnel.

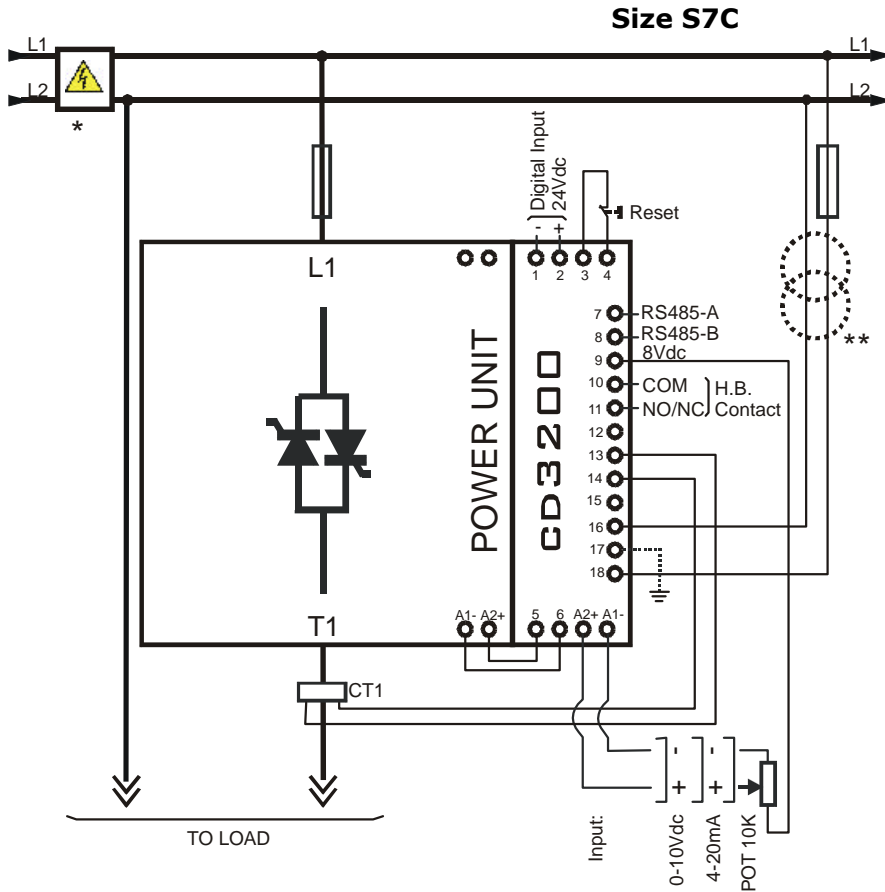

\* The user installation must be protected by electromagnetic circuit breaker or by fuse isolator

\*\* If the Auxiliary Voltage (written on the identification label) is different from Supply Voltage (to the load), use an external transformer as designated.

**NOTE:**

- To work, terminals 3-4 must be linked.
- The auxiliary voltage supply of Drive M unit must be synchronized with load voltage power supply (L2, L3).

**Load Type**

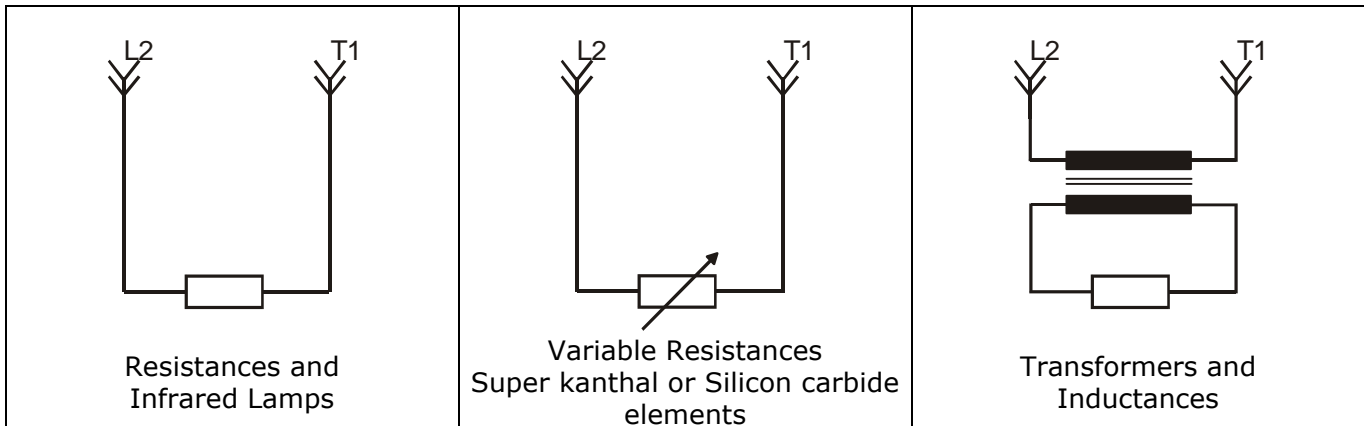

## 7.7 Diagram of control connection for size 110A



**Warning:** this procedure can be done just by specialized personnel.

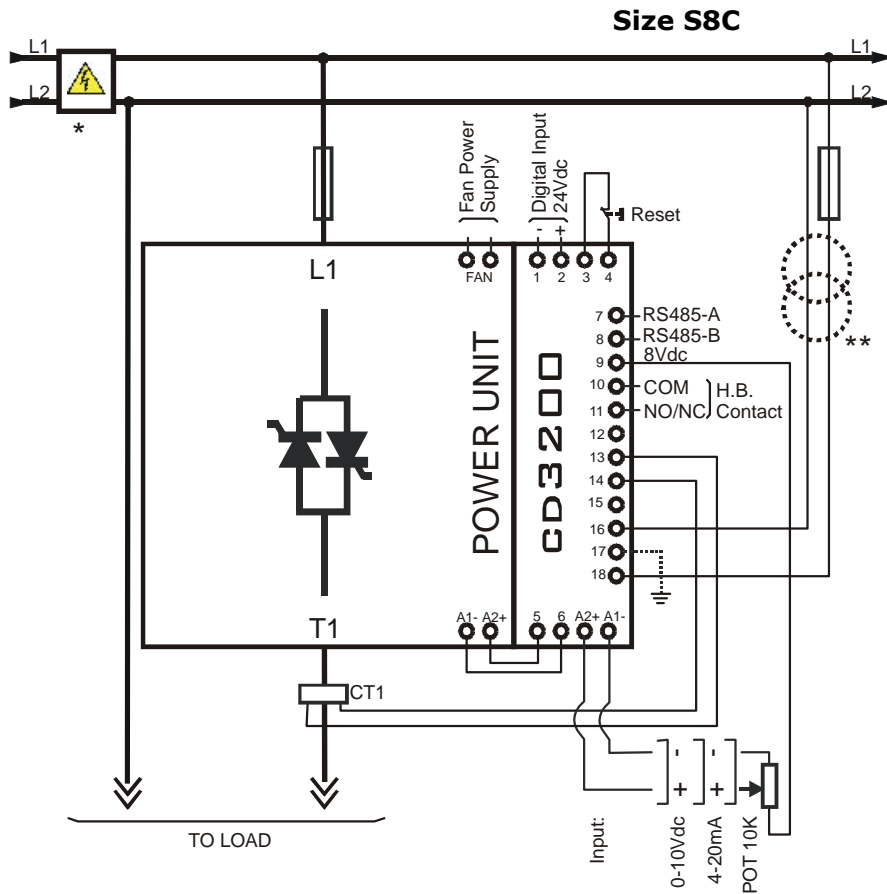

\* The user installation must be protected by electromagnetic circuit breaker or by fuse isolator

\*\* If the Auxiliary Voltage (written on the identification label) is different from Supply Voltage (to the load), use an external transformer as designated.

**NOTE:**

- To work, terminals 3-4 must be linked.
- The auxiliary voltage supply of Drive M unit must be synchronized with load voltage power supply (L2, L3).

**Load Type**

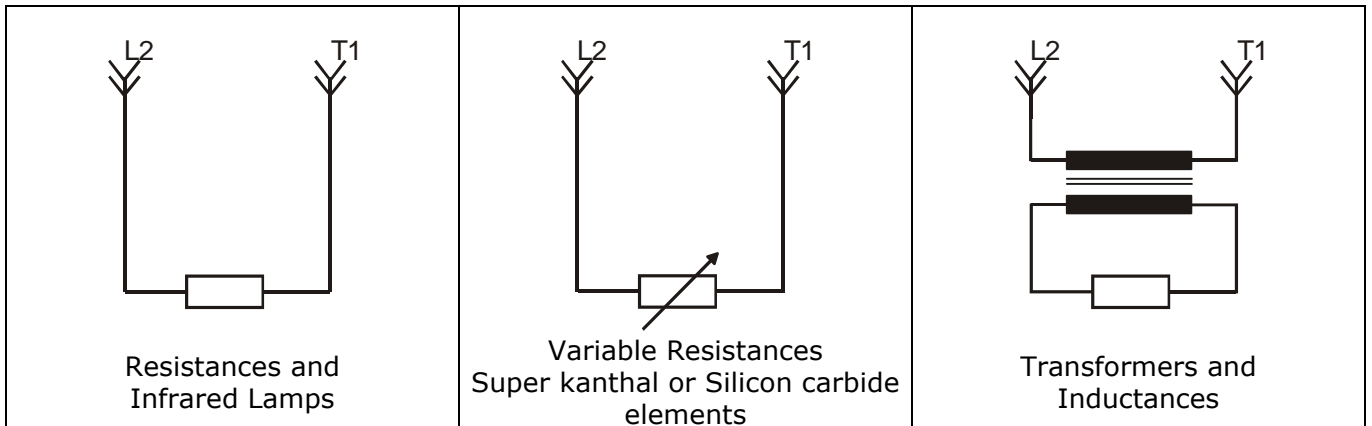

## 8 Technical features

### 8.1 Power output features

Current (A)	Voltage range (V)	Repetitive peak reverse voltage		Latching current (mAeff)	Max peak one cycle (10msec.) (A)	Leakage current (mAeff)	I <sup>2</sup> T value thyristor tp=10msec	Frequency range (Hz)	Power loss I=Inom (W)	Isolation Voltage Vac
		(480V)	(600V)							
15A	24÷480	1200	1200	150	230	15	610	47÷70	18	2500
25A	24÷480	1200	1200	150	230	15	610	47÷70	30	2500
35A	24÷600	1200	1600	250	400	15	780	47÷70	42	2500
45A	24÷600	1200	1600	250	600	15	1800	47÷70	54	2500
60A	24÷600	1200	1600	450	1000	15	4750	47÷70	72	2500
90A	24÷600	1200	1600	450	2000	15	19100	47÷70	108	2500
110A	24÷600	1200	1600	450	1540	15	11300	47÷70	137	2500

### 8.2 Derating curve

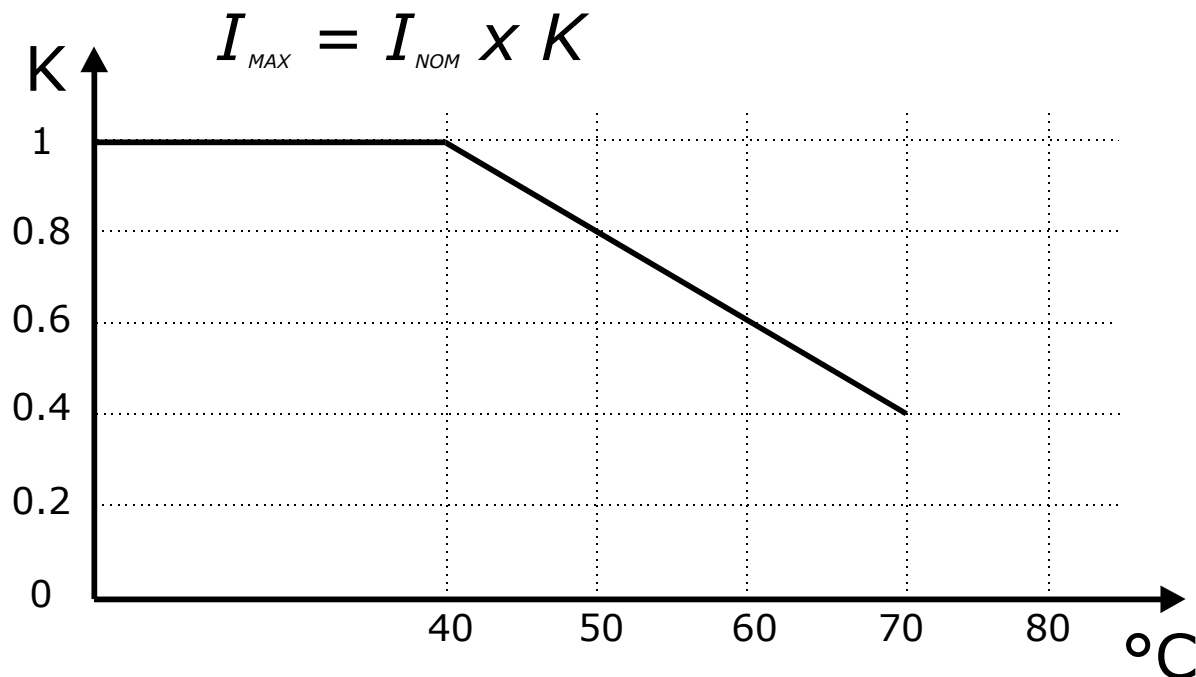

### 8.3 Cooling fans

The thyristor units from size 45A to 90A are equipped with a cooling fan. the supply voltage is standard 230VAC ±15% 50/60Hz or optional 110VAC ±15% 50/60Hz.

The fan's power consumption is below listed:

Size	CE Number of fans	UL LISTED US Number of fans
S8C	One Fan - 14W	One Fan - 14W



## 9 Led status and alarms

### 9.1 LED Status Table

LED	STATUS	DESCRIPTION
For all Size		
Aux	○	Auxiliary supply is not connected
	●	Auxiliary supply is connected and board is OK
ON	○	OFF Condition(Load IS NOT Powered)
	●	ON Condition(Load IS Powered)
SC	○	SCR OK
	●	SCR short circuit
	⦿	no External Enable (see par. 11.4)
HB	○	Load OK
	●	Load Fault

○	= OFF
●	= ON
⦿	= Flashing

### 9.2 Events and alerts that don't stop CD3200

The following events and alerts don't stop the unit:

- SCR Short Circuit (only with the HB option)
- Heater Break (only with the HB option)

When one of these alarms is active, the HB relay change status.

### 9.3 Heater break alarm and scr short circuit (HB Option)

The Heater Break Alarm is a circuit to diagnostic partial or total load failure, short circuit on SCR and fuses failure.

- sensibility better than 20%;
- alarm stored in memory;
- this alarm is associated to relay output 0.5A at 125VAC.



*The Heater Break circuit to work properly must have at least an input of 25% of the nominal current.*

H.B. circuit read load current via a current transformer 25-50/0.05 or 100/0.05 depending on thyristor size. Minimum current is 30% of the current transformer size's. If load current is below this value make two turns or more around current transformer. H.B. circuit also diagnoses fuse failure.

### 9.3.1 HB alarm contact (Terminals 10-11)

CD3200 is supplied with a normally closed (N/C) contact.

In alarm condition and without auxiliary voltage the contact is closed (relay coil not energized). In normal condition (no alarm) the contact is open (relay coil energized).

if you wish to change the alarm contact put the jumper as shown.

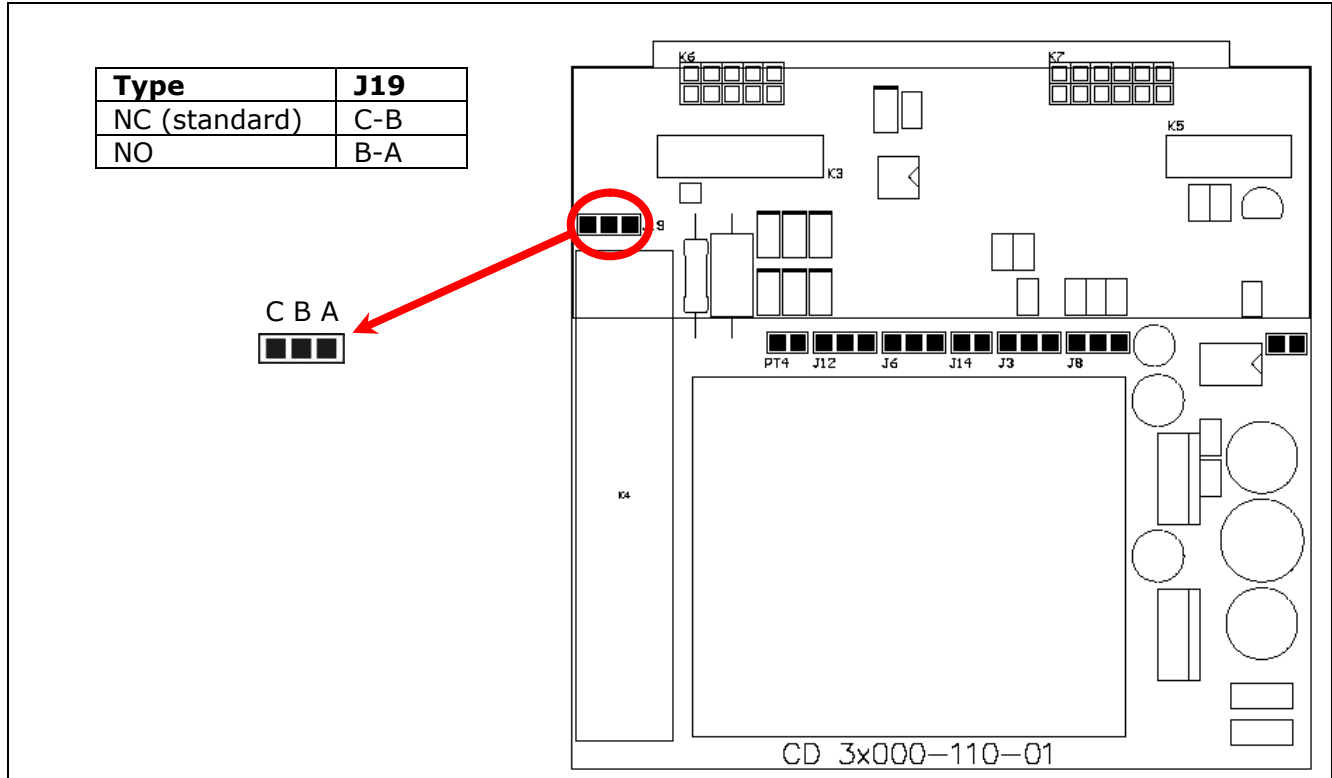

### 9.3.2 HB Calibration

An automatic function sets the Heater Break Alarm.  
The auto setting function is described to par. 10.2.2

If load current decreases for partial or total load failure (sensitivity 20%) the yellow LED become ON and alarm relay change status.

If CD3200 is still in conduction with no input signal (LED green OFF) it means that there is a short circuit on thyristors and red LED (SC) become ON.

The diagnostic is active only when the switching period is longer than 60ms(3main voltage cycles).  
If the load has been changed calibration procedure must be done again.

### 9.3.3 Heater Break RESET

To reset Heater Break Alarm open RESET contact on terminal 3-4.

## 10 Types of firing mode



**Warning:** this procedure can be done just by specialized personnel.

### 10.1 Soft Start + Phase Angle (S+PA)

For change this Firing mode use software configurator or the parameter on serial link.

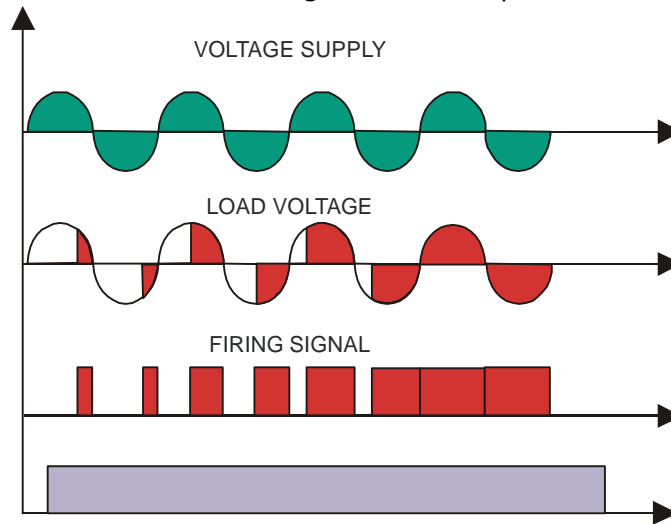

This is an additional feature to Phase Angle. The Unit start with a ramp that progressively increase the thyristor firing angle up to arrive to final value. Soft start is an important feature to reduce the inrush current with transformers when are switched ON and with cold resistance that are very close to a short circuit when cold resistance are switched ON.

### 10.2 Phase Angle (PA)

For change this Firing mode use software configurator or the parameter on serial link.

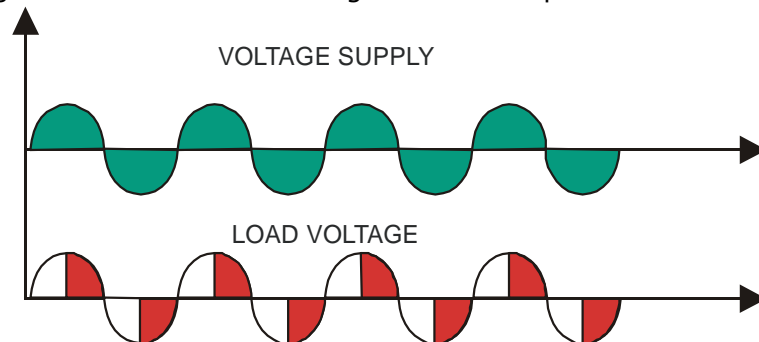

With Phase Angle is possible to control the power to the load allowing to Thyristor to be in conduction for a variable part of the voltage supply cycle. The load power can be adjusted from 0 to 100% as a function of analog input signal, normally delivered by temperature controller or by potentiometer. Normal it's used with inductive loads. The only disadvantage with phase angle is the generation of interferences that can be reduced with filters.

### 10.2.1 Current limit action

Usually with Phase Angle it is necessary to use the current limit when the CD3200 is connected to a transformer or cold resistance.

When the current to the load exceeds the set current limit value, the unit decreases the voltage output to maintain the current below the current limit set.

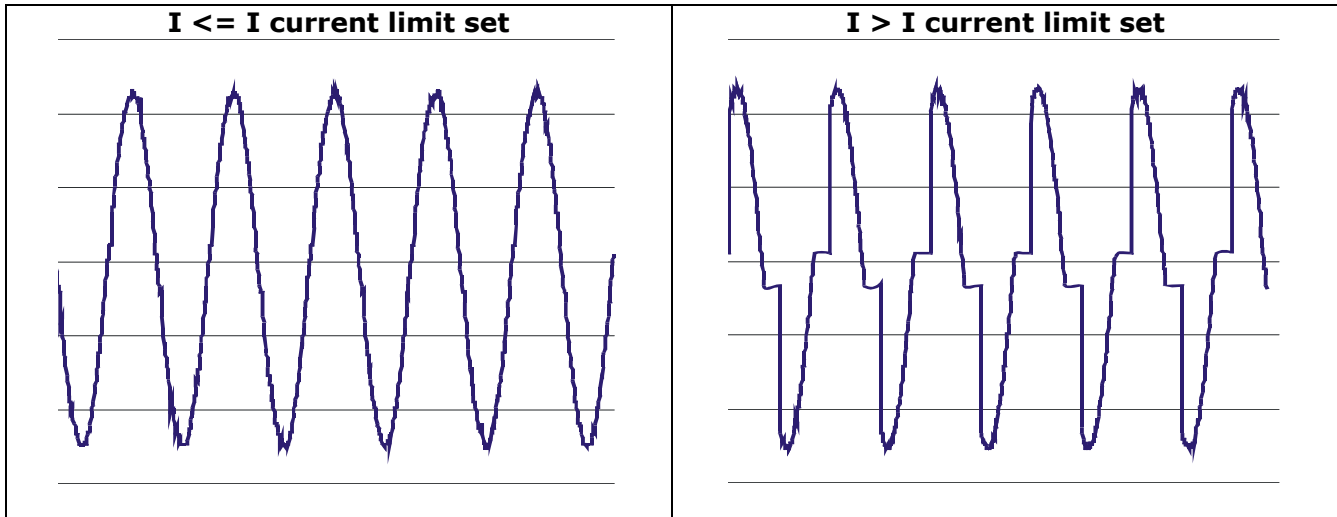

### 10.2.2 Calibration Procedure and Current limit set

The Current limit is set up through the R13 trimmer on Frontal Board PCB (see par.6.5):

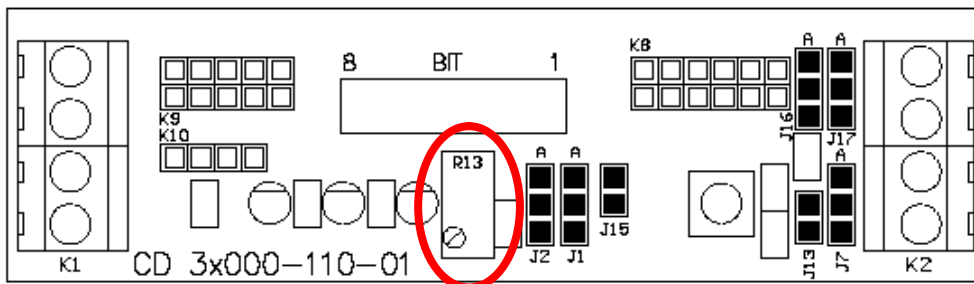

Turned completely in counter-clockwise sense, will be Current limit = 0%.

Turned completely in clockwise sense, will be Current limit = 100% of the Max value of current transformer (25/0.05, 50/0.05 or 100/0.05 depending on thyristor size).

Minimum current is 10% of the current transformer size's. If load current is below this value make two turns or more around current transformer. H.B. circuit also diagnoses fuse failure.

If the External current limit profiling is used, before turning the R13 trimmer, supplying with 10Vdc the secondary analogic input (see par. 11.3.3).

In order to make the Calibration Procedure, follow these indications:

- Turned completely in counter-clockwise sense the trimmer R13
- Start the Calibration using the Key "Cal" place on the frontal part of the unit, or with the digital input (terminals 1-2).
- All LEDs are on, this means that calibration procedure is active.
- Turn the trimmer R13 in clockwise sense and set the wished current limit.
- After a minute the CD3200 comes back to the initial situation and the values of tension and current are saved in memory

If the load has been changed calibration procedure must be done again.

### 10.3 Feed-back ( control mode )

The type of Feed-back select has already configured in line with customer requirements that are defined in the complete product code. The product code is written on the identification label. However, if you wish to change type of Feed-back use software configurator or the parameter on serial link.

If the digital input is set as Feed-back Selection (see par. 11.4), it's possible to change the select Feed-back with the Voltage Feed-back (V), simply activating the input.

The feed-back defines the Control Mode. It's possible to have:

- V=Voltage feed-back.  
The input signal is proportional to the output voltage. This means that input signal becomes a voltage demand. This control mode compensate the voltage fluctuation of the incoming line supply.
- I=Current feed-back.  
The input signal is proportional to the current output. This means that input signal becomes a current demand. This control mode maintain the current also if the load impedance changes.
- V<sup>2</sup>=Square Voltage feed-back.  
The input signal is proportional to the output square voltage. This means that input signal becomes a power demand. The power remains constant if the load impedance doesn't change.
- VxI=Power feed-back.  
The input signal is proportional to the power output. This means that input signal becomes a power demand. The power remains constant also if voltage and load impedance change. This feed-back is used with silicon carbide elements that change its resistive value with temperature and with age. In addition it compensate the voltage fluctuation of the incoming line supply.

**If the user change the type of feed-back, it's necessary repeat the calibration procedure (see par. 10.2.2)**

# 11 Connection description

## 11.1 Electronic boards

To have access to the electronic boards the user must removing the unit's cover(see par.6.5)



**Warning:** this procedure can be done just by specialized personnel.

### 11.1.1 Jumper's position on Front PCB

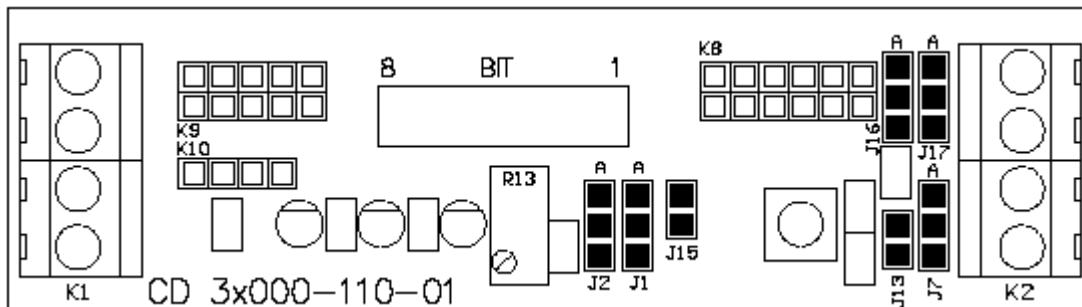

### 11.1.2 Jumper's position on Main PCB

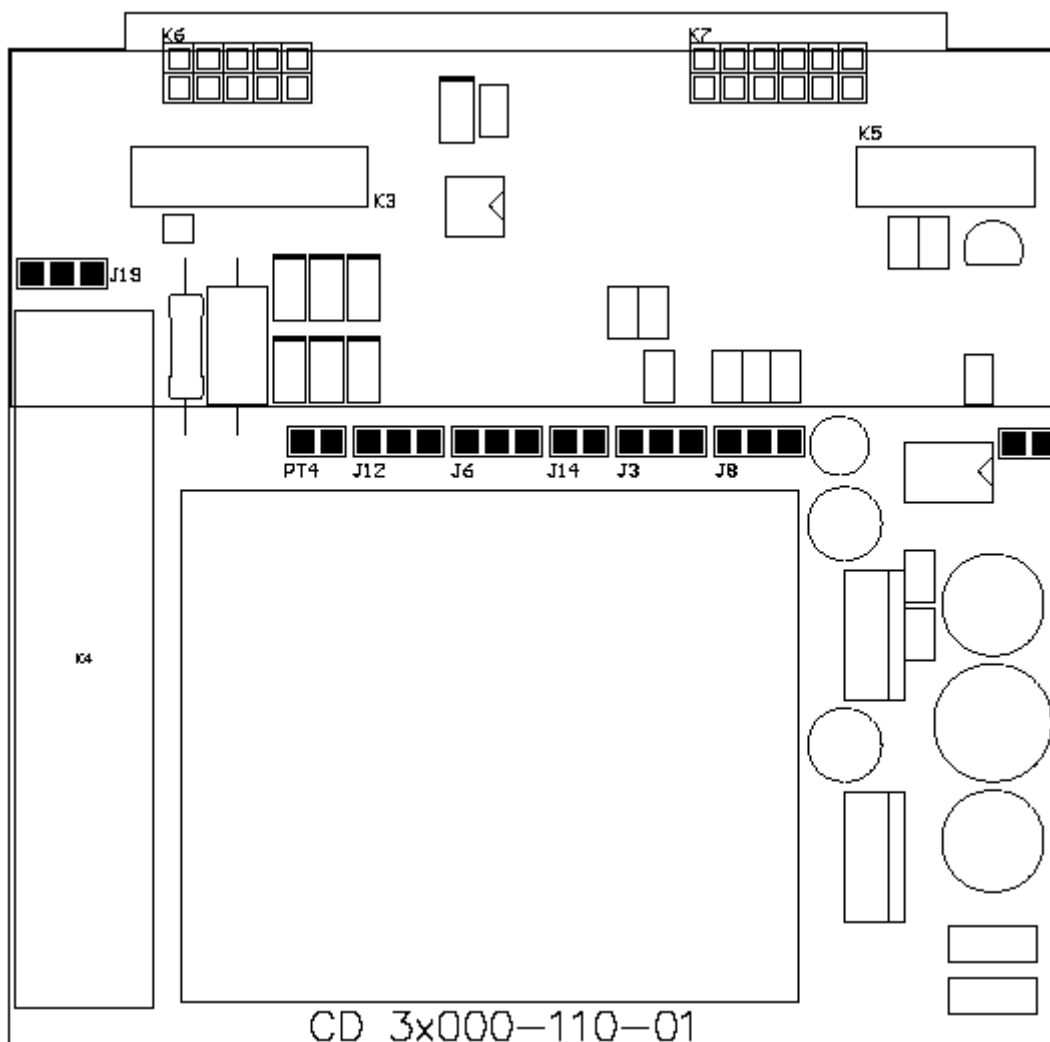

## 11.2 Auxiliary power supply connections

The auxiliary voltage supplies the electronic board, so check the nominal voltage on the label.

Terminal	Description
16	Auxiliary voltage supply (for the electronic board)
18	Auxiliary voltage supply (for the electronic board)

To change auxiliary supply voltage sold the correct link-jumper on main PCB.



**Warning:** this procedure can be done just by specialized personnel.

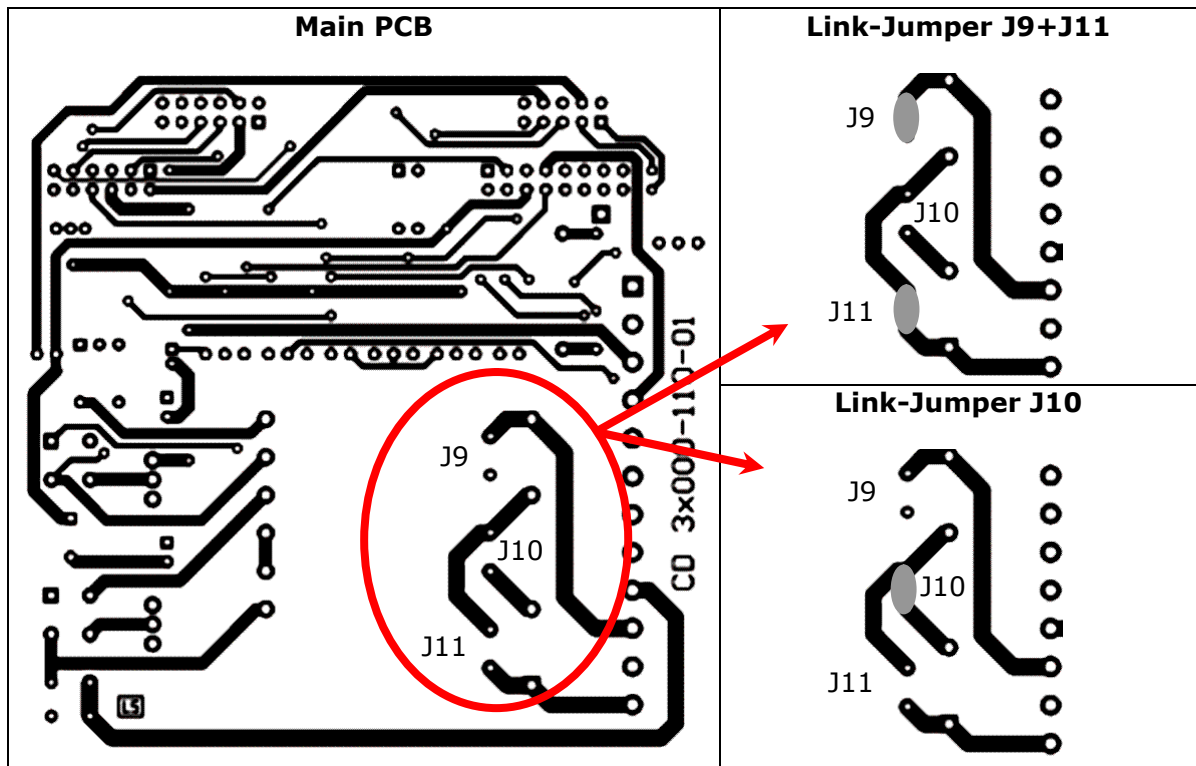

Transformer Type	Link-Jumper J9+J11	Link-Jumper J10
TR-605 120V	90:130V	-
TR-605 230V	170:265V	300:530V
TR-605 300V	230:345V	510:690V

- The type of mounted transformer depends of the chosen Auxiliary Voltage in the order code. (See par. 5.2)
- If the Auxiliary Voltage (written on the identification label) is different from Supply Voltage (to the load), use an external transformer with primary equal to load voltage and secondary equal to the Auxiliary Voltage.

### 11.3 Analog inputs

CD3200 thyristor unit have an analogue input to drive the output and a second analogue input that can be use for external current profiling.



*Before to operate on CD3200, make sure that the Power voltage and auxiliary voltage supply are not connected.*

#### 11.3.1 Input command signal configuration (Terminals A2+ and A1- see par.7.3)

The Input command signal is already configured in line with customer requirements that are defined in the complete product code. The product code is written on the identification label. However, if you wish to change the input type (i.e. from 0÷10V to 4÷20mA) proceed as follows.



**Warning:** *this procedure can be done just by specialized personnel.*

To configure the input type, set the jumper as below represented:

**Front PCB**

Type	Input features		J7	J16	J17
0÷10V	Impedance	10KΩ	C-B	B-A	B-A
POT	Impedance	10KΩ min	C-B	B-A	B-A
4÷20mA	Impedance	100Ω	B-A	B-A	B-A

**When operator finishes to configure the hardware setting he must do the input calibration procedure**



### 11.3.2 Input calibration procedure



**Warning:** this procedure can be done just by specialized personnel.

**This procedure is needed only if you change the input type**

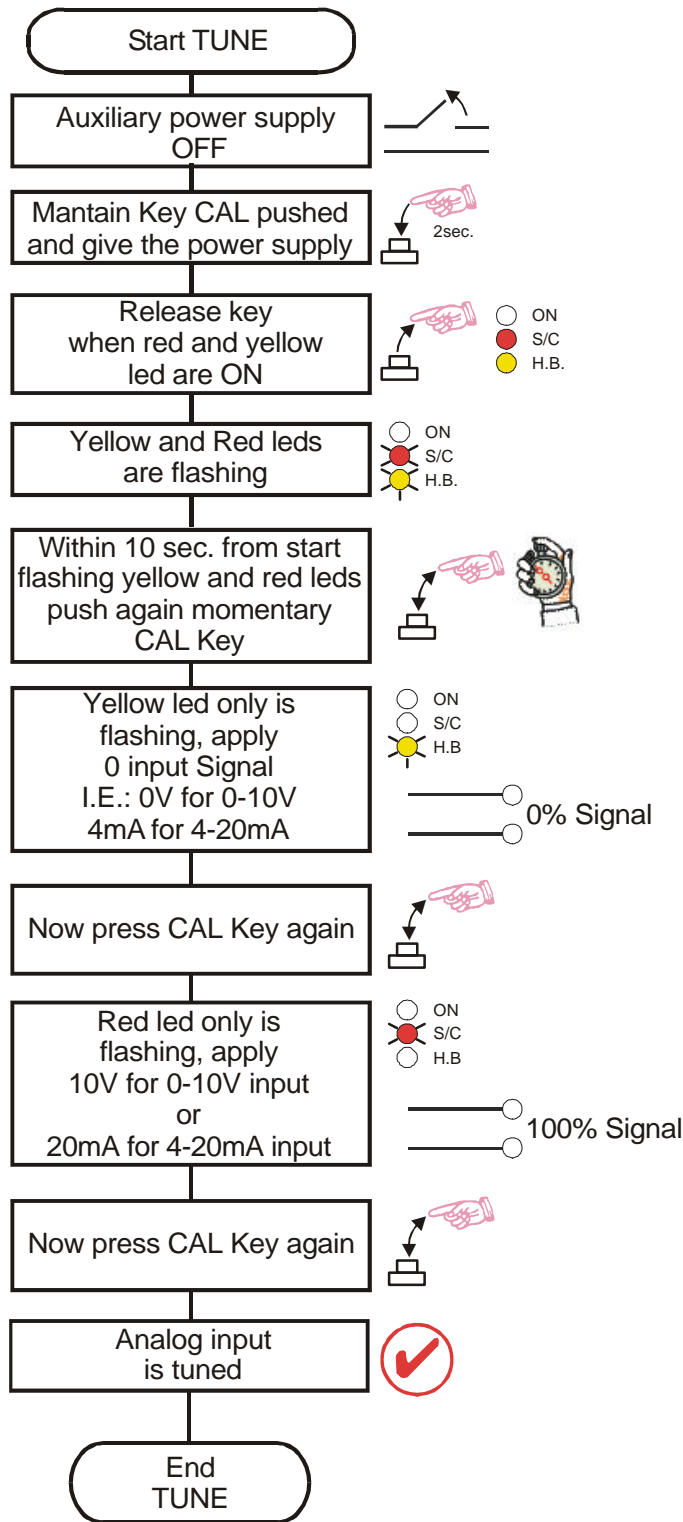

**11.3.3 Secondary input (Terminals 12 e A1- see par. 7.3)**

This analogue input 0-10V may be configured for External current limit profiling. The Secondary input is already configured in line with customer requirements that are defined in the complete product code. The product code is written on the identification label. However, if you wish to change the input type proceed as follows.



**Warning:** this procedure can be done just by specialized personnel.

To configure the input, set the jumper as below represented:

**Front PCB**

<b>Current Limit</b>	<b>J2</b>	<b>J1</b>
Regulation through the R13 trimmer, mounted on the front PCB. (secondary input not used)	C-B	C-B
Regulation through the secondary input (External current limit profiling)	B-A	C-B

**When operator finishes to configure the hardware setting he must do the calibration procedure (see par. 10.2.2)**

## 11.4 Digital Input

CD3200 thyristor unit has two digital inputs.

### 11.4.1 External Calibration (Terminals 1 and 2 see par. 7.3)

Supply with 24Vdc terminals 1-2 to start the calibration procedure (see par. 10.2.2)

Is possible configure the input also like:

- External Enable = to Enable or Disable the Unit.  
Without Enable the out is always to zero and red led (SC) flashing, otherwise the out will follow the input signal.
- Feed-back Selection = to switch the set Feed-back with the voltage Feed-back (V)  
Without Digital Input the Unit use the voltage Feed-back, otherwise use the set Feed-back.

to configure the input type, set the jumper as below represented:

**Main PCB**

CD 3x000-110-01

Type	J12	J6	J14
External Calibration	C-B	C-B	Open
External Enable	B-A	Open	Open
Feed-back Selection	C-B	Open	Close

\* With the Feed-back Selection open the jumper J15 on the Front PCB board

**If you use the input like External Enable or like Feed-back Selection, is not possible use the input for the Calibration Procedure**

#### 11.4.1.1 Reset (Terminals 3 and 4 see par.7.3)

Open link to terminals 3-4 to stop the CD3200 thyristor unit.  
When an alarm occurs use reset to clear the alarm (see par. 9.3).

### 11.5 RS485 serial connection

The serial communication port is on Terminals 7 and 8.  
 On this port may be done a network up to 255 CD3200.

Terminal	Description
7	RS485 A
8	RS485 B

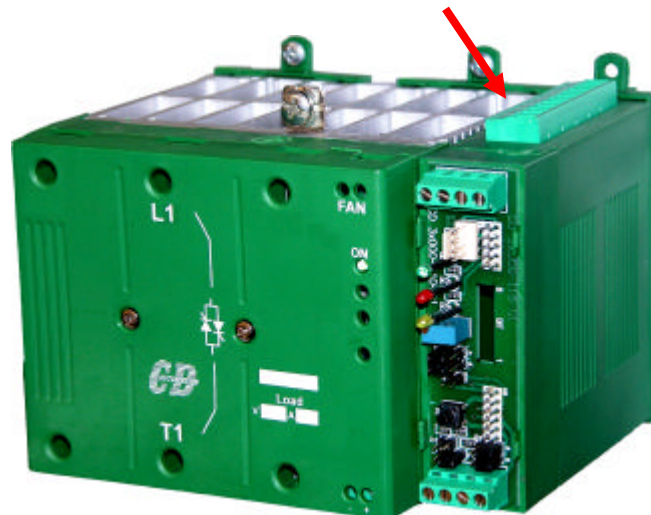

### 11.6 PG Connector

The programmer port (PG) is used to configure the thyristor unit with the configuration software and with the programmer cable.  
 Once removed the cover, put a side of cable in PG connector and the other side in the PC RS232(9PIN) serial port

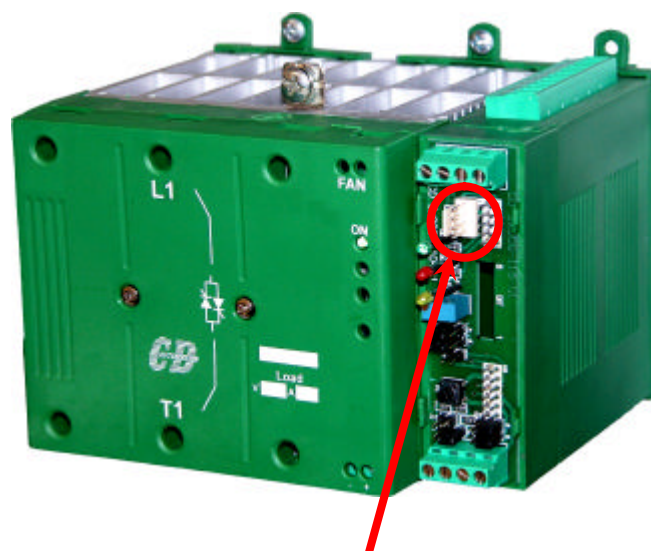

**PG Connector**

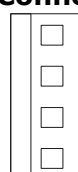

## 11.7 Address configuration

To configure communication address remove cover and set the dip-switch as below specified.

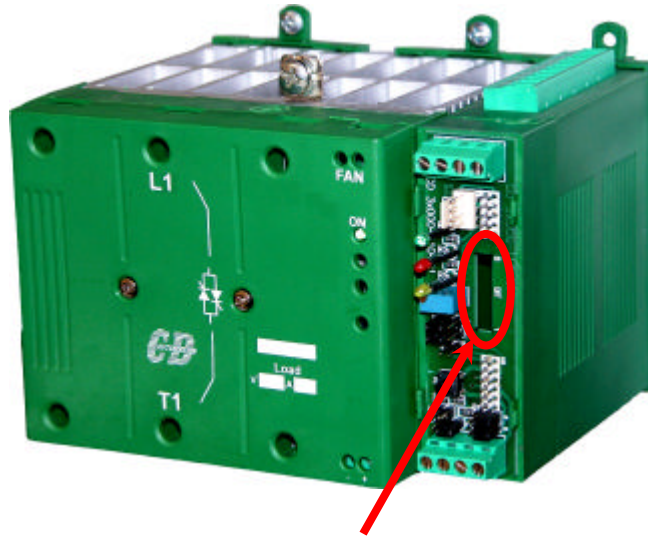

**Dip Switch**



Convert the Address Number in Binary for Example: 150 Dec = 10010110 Bin  
 The dip switch number corresponds to the bit number:

Address Number	Dip Switch Number							
	8	7	6	5	4	3	2	1
150 Dec -> 10010110 Bin	1 (On)	0 (Off)	0 (Off)	1 (On)	0 (Off)	1 (On)	1 (On)	0 (Off)

For convert the Number in Binary you can use this method:

Dip Switch Number have this value:

Value	Dip Switch Number							
	8	7	6	5	4	3	2	1
	128	64	32	16	8	4	2	1

The Address Number Ex. 150 = 128(Dip 8) + 16(Dip 5) + 4(Dip 3) + 2(Dip2)

## 12 Fuses and Fuse holder

CD3200 unit must be protected by fuses against short circuit selecting the proper  $I^2t$  that must be lower than the thyristor one. The same caution must be taken if Circuit Breaker is used. Remember that is very difficult to protect the thyristor if this choice is done.



**WARNING!!** USE SEMICONDUCTOR FUSES ONLY WITH proper  $I^2t$

### 12.1 Fuses and Fuse Code for UL

SIZE	Bussmann Div Cooper (UK) Ltd (200 kARMS Symmetrical A.I.C.)				Ferraz Shawmut SA (200 kARMS Symmetrical A.I.C.)				Qty
	Fuse CODE	Current (ARMS)	$I^2T$ (A <sup>2</sup> sec)	Vac	Fuse CODE	Current (ARMS)	$I^2T$ (A <sup>2</sup> sec)	Vac	
15A	FWC 16A10F	16	150	600	660 Grb 10-16	16	145	660	1
25A	FWC 32A10F	32	600	600	660 Grb 10-32	32	740	660	1
35A	FWP 40A14F	40	750	700	CP URC 14x51/40	40	700	660	1
45A	FWP 50A14F	50	1800	700	CP URC 14x51/50	50	1500	660	1
60A	FWP 80A22F	80	6600	700	CP URD 22x58/80	80	3800	660	1
90A	-	-	-	-	CP URQ 27x60/125	125	6970	660	1
110A	-	-	-	-	CP URQ 27x60/160	160	15000	660	1



Other Fuses at your choice must have  $I^2t$  20% less than thyristor's  $I^2t$ .



High speed fuses are only used for the thyristor protection and can not be used to protect the installation.



The user installation must be protecting by electromagnetic circuit breaker or by fuse isolator.



The warranty of thyristor is null if no proper fuses are used. See tab above.



## 12.2 Fuses and Fuse Code for CE

SIZE	Fuse and Fuse holder CODE	Fuse CODE	Current (ARMS)	I <sup>2</sup> T (max) (A <sup>2</sup> sec.)
15A	FFH1038/16A	FU1038/16A	16	150
25A	FFH1038/32A	FU1038/32A	32	600
35A	FFH1451/40A	FU1451/40A	40	1650
45A	FFH1451/50A	FU1451/50A	50	2000
60A	FFH2258/80A	FU2258/80A	80	6550
90A	FFH2258/125A	FU2258/125A	125	14000
110A	FFH2760/160A	FU2760/160A	160	15000



*Other Fuses at your choice must have I<sup>2</sup>t 20% less than thyristor's I<sup>2</sup>t.*



*High speed fuses are only used for the thyristor protection and can not be used to protect the installation.*



*The user installation must be protecting by electromagnetic circuit breaker or by fuse isolator.*



*The warranty of thyristor is null if no proper fuses are used. See tab above.*



### 12.3 FuseHolder size

**for size 15A - 25A**

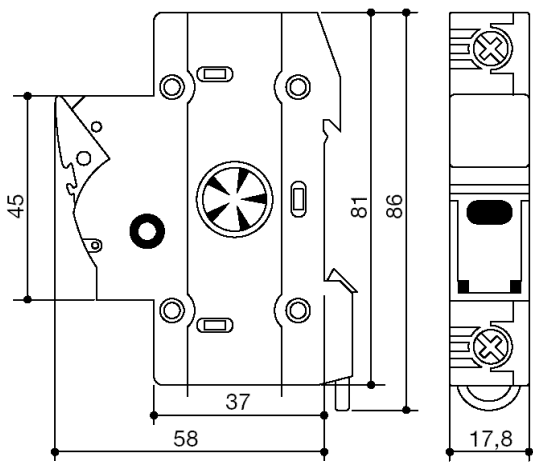

**for size 35A - 45A**

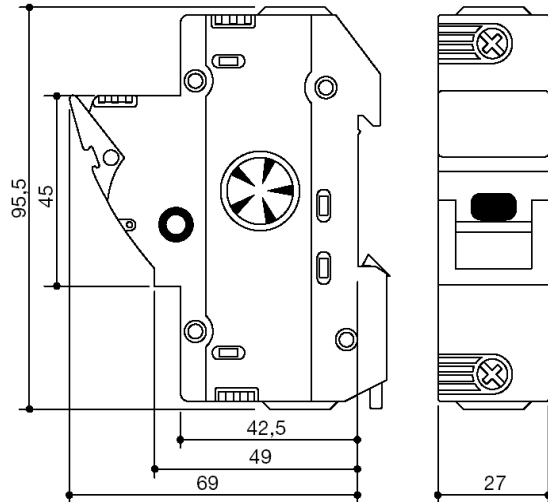

**for size 60A - 90A(CE)**

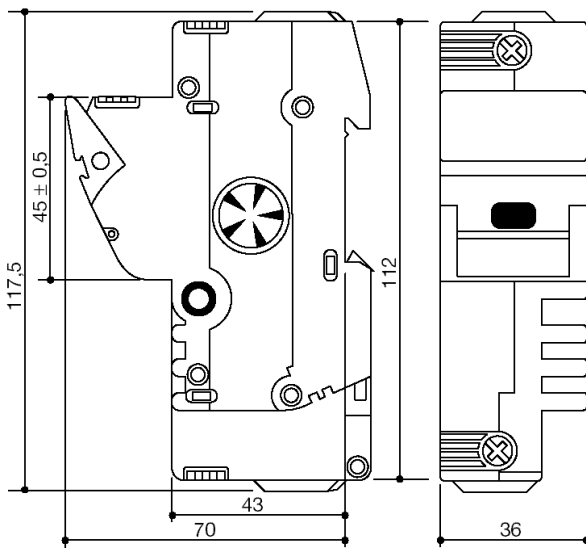

**for size 90A(UL) - 110A**

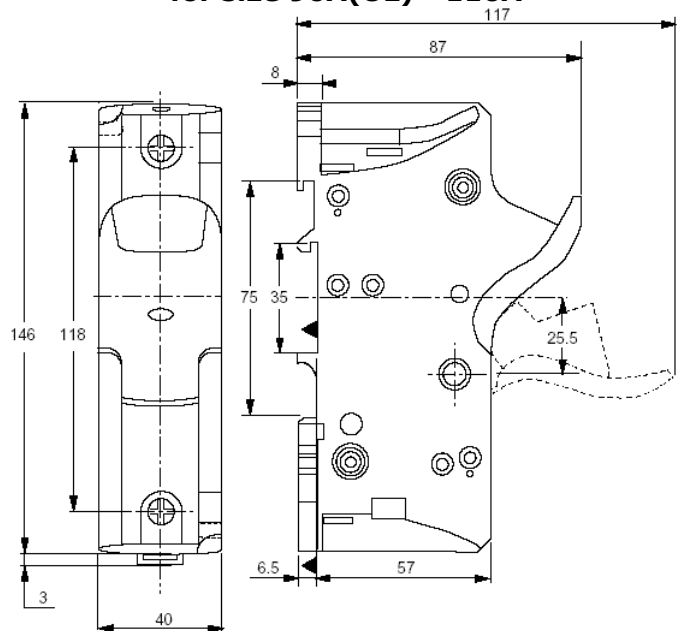



## 13 Modbus communication



The CD3200 is equipped with two-wire RS485- serial communication. This means that communication can be between the CD3200 and a master device (Ex. a computer or terminal).

### 13.1 Physical requirements

Character Transmission

Data format is fixed to be one start bit, eight data bits, one stop bit and the parity none.

### 13.2 Modbus Rtu Protocol

The standard RS485 Communications use the industry standard MODBUS RTU protocol. The following restrictions are imposed:



- A baud rate is fixed to 9600 Baud only.
- Support for multi-parameter Write operations is limited to support of the Multi-Word Write Function (Number 16) but permits writing only one parameter per message.
- MODBUS Function 17 (Report Slave ID) is not supported.

The following MODBUS functions are supported:

Function	Function Number
Read Holding Registers (Read n Word)	03
Preset Multiple Registers (Write n Word)	16

### 13.3 Message formats

The first character of every message is the Controller address, in the range 1 - 255 and 0 for broadcast messages.

The second character is always the Function Number.

The content of the remainder of the message depends upon this Function Number.

In most cases the Controller is required to reply to the message by echoing the address and Function Number.



*Broadcast messages are supported at address 0 (to which the CD3200 responds by taking some action without sending back any reply).*

Data is transmitted as eight-bit binary bytes with one start bit, one stop bit and parity checking set to none. A message is terminated simply by a delay of more than three character lengths at the Baud rate used; any character received after such a delay is considered to be the potential address at the start of a new message.

Since only the RTU form of the protocol is supported, each message is followed by a two-byte CRC 16 (a 16-bit cyclic redundancy checksum).

This checksum is calculated in accordance with a formula which involves recursive division of the data by a polynomial, with the input to each division being the remainder of the results of the previous division.

The dividing polynomial is:

$$2^{16} + 2^{15} + 2^2 + 1 (\text{Hex } 18005)$$

But this is modified in two ways:

- because the bit order is reversed, the binary pattern is also reversed, making the most significant bit (MSB) the right-most bit;
- Only the remainder is of interest, the right-most (most significant) bit can be discarded.



Thus, the polynomial has the value Hex A001.

### **Bit order**

#### **Normal bit order**

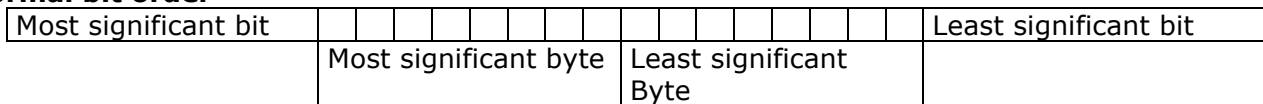

#### **Reversed bit order**

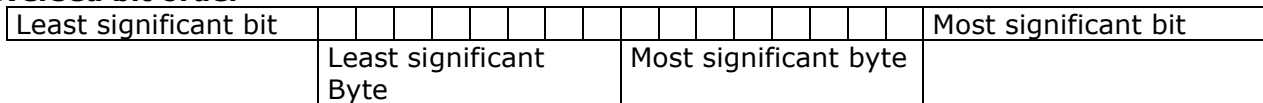

*N.B.: Reversed order applies, so CRC16 returns Reversed bit order*

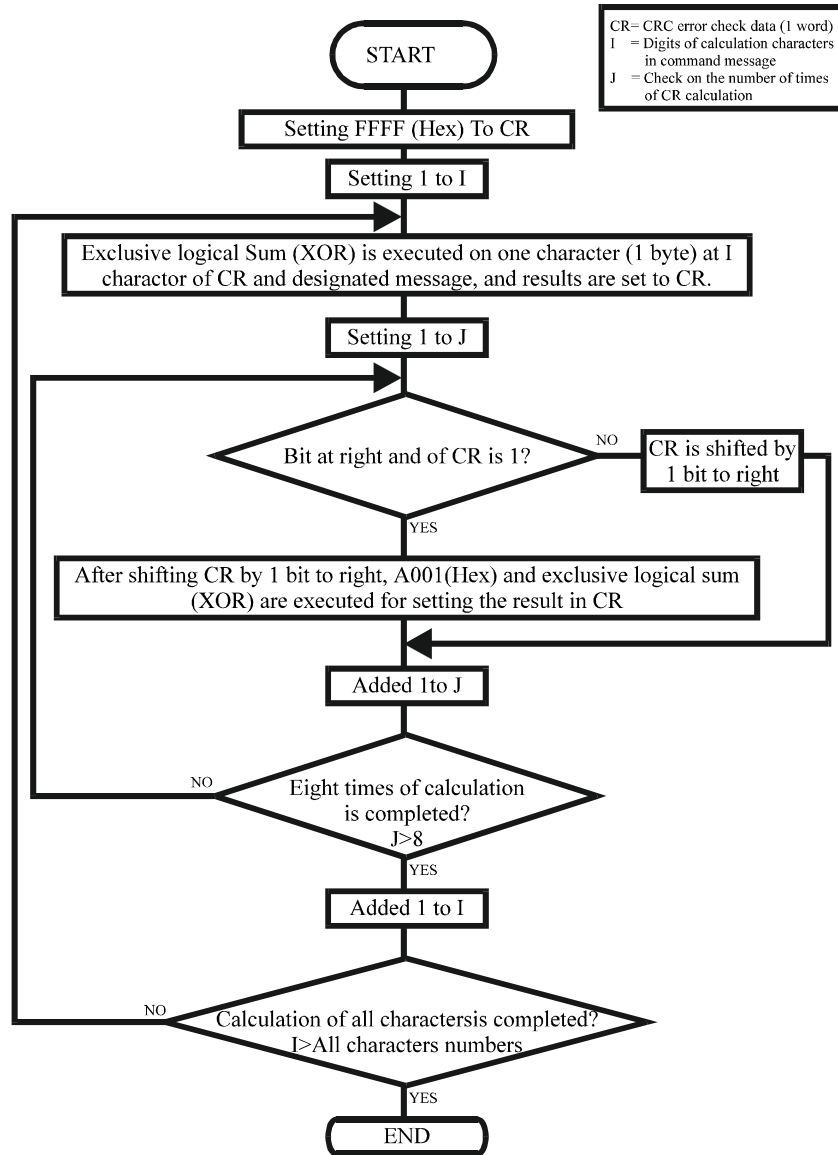

**C Language CRC 16 Example**

```

static short CRC16 (unsigned char *p_first,unsigned char *p_last)
{
    unsigned int crc=0xffff;
    short j;

    for (;p_first<=p_last;p_first++)
    {
        crc ^= *p_first;
        for(j=8;j>0;j--)
        {
            if(crc & 0x0001)
            {
                crc = crc >> 1;
                crc ^= 0xA001;
            }
            else
            {
                crc = crc >> 1;
            }
        }
    }
    return (crc);
}
    
```

## 13.4 Read holding registers (read n words) – Function 03

The message sent to the unit to obtain the value of one or more registers comprises the following eight bytes:

Addr. Unit	Func.	Addr of 1° Word		N° of Word		CRC 16	
	3 3Hex	HI	LO	HI	LO	LO	HI

The normal reply will echo the first two characters of the message received followed by a single-byte data byte count (which will not include itself or the CRC).

For this message, the count value equals the number of parameter values read multiplied by two. Following the byte count, the specified numbers of parameter values are transmitted, followed by the CRC16 bytes:

Addr. Unit	Func.	Cont.	1° Value			Last Value		CRC 16	
	3 3Hex		HI	LO		HI	LO	LO	HI

## 13.5 Preset multiple registers (write n words) - Function 16

This is an eleven-byte message. Only one parameter may be written for each received message. The usual pre-amble is followed by the address of the parameter to be written, a two-byte word count (always set to 1), a single-byte byte count (always set to 2), the value to be written and the CRC16 bytes:

Addr. unit	Func.	Addr of 1° Word		N° of Word		Cont.	Valore		CRC 16	
	16 10Hex	HI	LO	0	1	2	HI	LO	LO	HI

The unit normally responds with the following eight-bit reply:

Addr. Unit	Func.	N° of Word		N° Word		CRC 16	
	16 10Hex	HI	LO	0	1	LO	HI

## 13.6 Error and exception responses

If a received message contains a corrupted character (parity checks failure, framing error etc.) or if the CRC16 check fails, or if the received message is otherwise syntactically flawed (e.g. byte count or word count is incorrect), the CD3200 will ignore that message.

If the received message is syntactically correct but nonetheless contains an illegal value, the CD3200 will send a five-byte exception response as follows:

Addr. unit	Func.	N.Exception	CRC 16	
			LO	HI

The Function Number byte contains the function number contained in the message which caused the error,  
With its top bit set (i.e. Function 3 becomes 0x83) and the Exception Number is one of the following codes:

Code	Name	Cause
1	ILLEGAL FUNCTION	Function number out of range
2	ILLEGAL DATA ADDRESS	Parameter ID out of range or not supported
3	ILLEGAL DATA VALUE	Attempt to write invalid data/required action not executed



*NOTE: Writing a parameter value equal to its current value is a valid transaction; this will not cause an error response.*

## 13.7 Modbus parameters

<b>P001L (H01)</b>	<b>Byte Lo = Load Voltage</b>	<b>R</b>
Function:	This parameter show the Voltage rms value	
Min/Max:	0 ÷ 255 (0 ÷ FF Hex)	
Value:	Value depends on the Unit type	
<b>P001H (H01)</b>	<b>Byte Hi = Load Current</b>	<b>R</b>
Function:	This parameter show the Current rms value	
Min/Max:	0 ÷ 255 (0 ÷ FF Hex)	
Value:	Value depends on when turns have current transformer and from his size's	
Example:	With one passage on the current transformer (CT) 25/0.05A, the max value corresponds to the max value of the CT: Read value=255 (FF Hex) -> Load Current= 25A	
<b>P002L (H02)</b>	<b>Byte Lo = Set-point Voltage</b>	<b>R/W</b>
Function:	This parameter is the Set-point voltage saved by the Calibration Procedure	
Min/Max:	0 ÷ 255 (0 ÷ FF Hex)	
<b>P002H (H02)</b>	<b>Byte Hi = Set-point Current</b>	<b>R/W</b>
Function:	This parameter is the Set-point of current below which HB alarm occurs	
Min/Max:	0 ÷ 255 (0 ÷ FF Hex)	
Value:	This value is the load current(P001H) minus % value of parameter P126H	
<b>P003 (H03)</b>	<b>Status Table</b>	<b>R</b>
Function:	It's a tab in bit that represent the "Status" of thyristor unit	
Value:	Bit 0 = 1 -> Short circuit on SCR Bit 1 = 1 -> Load Failure (HB Alarm) Bit 2 = 1 -> Output signal ON Bit 3 = 1 -> HB Calibration in progress Bit 4 = 1 -> Current Limit Flag Bit 5 = 1 -> Thermal switch	
<b>P004 (H04)</b>	<b>Command Table</b>	<b>R/W</b>
Function:	It's a tab in bit for remote commands via RS485	
Value:	Bit 0 = 1 -> Activate HB Calibration procedure Bit 1 = 1 -> Input Command from RS485 (see P005) Bit 2 = 1 -> Disable Output signal (Only with Input from RS485) Bit 3 = 1 -> Reset HB Alarm Bit 4 = 1 -> Current Limit via RS485 (see P007)	
Note:	When unit is switch off all command parameter are set to 0	
<b>P005L (H05)</b>	<b>Byte Lo = Input command signal</b>	<b>R</b>
Function:	This parameter reads the Input command signal (see par.7.3) When the P004 Bit1 =1 This parameter could be written and become the Input Command from RS485	
Min/Max:	0 ÷ 255 (0 ÷ FF Hex)	
Example:	Input 4mA -> P005L = 0 (0%) Input 12mA -> P005L = 128 (50%) Input 20mA -> P005L = 255 (100%)	

**P005H (H05)****Byte Hi = Ramped Input command signal****R**

Function:

This parameter reads the Input command signal after the ramp

Min/Max:

0 ÷ 255 (0 ÷ FF Hex)

Example:

Input 4mA -&gt; P005H = 0 (0%)

Input 12mA -&gt; P005H = 128 (50%)

Input 20mA -&gt; P005H = 255 (100%)

**P006 (H06)****Power adjust****R/W**

Function:

Its' a scaling factor of the Input command signal

Min/Max:

0 ÷ 255 (0 ÷ FF Hex)

Value:

from 0 = 0% of Output,

to 255 = 100% of Output.

Note:

This parameter limit the Output Power

OUT %

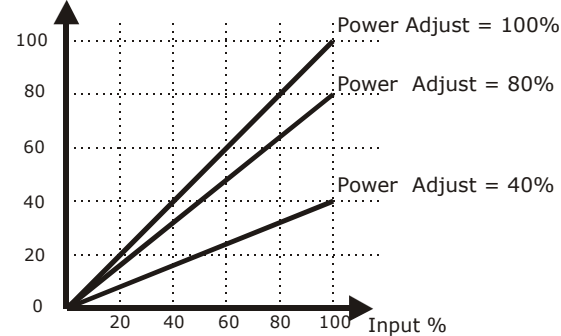
**P007 (H07)****Current Limit****R**

Function:

This parameter show the Current Limit value (see par. 10.2.2)

When the P004 Bit4 =1 This parameter could be written and become the Current Limit from RS485

Min/Max:

0 ÷ 255 (0 ÷ FF Hex)

Value:

Value depends on when turns have current transformer and from his size's

Example:

With one passage on the current transformer (CT) 25/0.05A, the max value corresponds to the max value of the CT:

Read value=255 (FF Hex) -&gt; Load Current= 25A

<b>P121 (H79)</b>	<b>CD Unit ID</b>	<b>R</b>
Function:	This parameter Identify the CD type Family	
Value:	CD32 Hex = CD3200 Family	
<b>P122 (H7A)</b>	<b>CD Ver</b>	<b>R</b>
Function:	This parameter is for internal use	
<b>P123 (H7B)</b>	<b>Password</b>	<b>R/W</b>
Function:	This parameter give the access to configuration	
Min/Max:	0 ÷ FFFF Hex	
Value:	9357 Hex = Writing parameters activated any value = Writing parameters disabled	
Note:	When the CD3200 comes out and then re-lighted, for change the parameters you must re-insert the password.	
<b>P124 (H7C)</b>	<b>Actual power</b>	<b>R</b>
Function:	This parameter show the actual value of the power demand	
Min/Max:	0 ÷ FFFF Hex	
Value:	from 0 = 0% output power, to 65535 = 100% output power.	
<b>P125L (H7D)</b>	<b>Byte Lo = Feed-Back Type</b>	<b>R/W</b>
Function:	This parameter set the Feed-Back Type	
Value:	00 Hex = V2 20 Hex = V 40 Hex = I 80 Hex = VxI	
<b>P125H (H7D)</b>	<b>Byte Hi = Tempo di Soft start</b>	<b>R/W</b>
Function:	The Unit start with a ramp that progressively increase the thyristor firing angle up to arrive to final value. The time is setted by this parameter	
Min/Max:	0 ÷ 255 (0 ÷ FF Hex)	
Value:	Each step is 50msec	
<b>P126L (H7E)</b>	<b>Byte Lo = HB Delay time</b>	<b>R/W</b>
Function:	This parameter set a delay to have HB alarm active	
Min/Max:	0 ÷ 255 (0 ÷ FF Hex)	
Value:	Each step is 50msec	
Note:	If Soft start option is enabled HB Delay time must be greater than Soft start time: P126L x 50msec > P125H x 50msec	
<b>P126H (H7E)</b>	<b>Byte Hi = HB sensibility</b>	<b>R/W</b>
Function:	This parameter is the maximum reduction of Load Current to establish the HB Alarm	
Min/Max:	0 ÷ 100 (0 ÷ 64 Hex)	
Value:	Each step is 1% from Nominal Current	
Note:	When you change this parameter, HB Calibration procedure is necessary.	
<b>P127 (H7F)</b>	<b>Power Set</b>	<b>R/W</b>
Function:	This parameter show the Power set saved by the Calibration Procedure	
Min/Max:	0 ÷ FFFF Hex	
Value:	from 0 = 0% output power, to 65535 = 100% output power.	



**P128L (H80)****Byte Lo = Integral****R/W**

Function:

This parameter is the integral time of the feed-back loop

Min/Max:

0 ÷ 255 (0 ÷ FF Hex)

Default:

50 Hex

Note:

If you increase integral time you increase the output stability, but you increase also the time to reach the set.

**P128H (H80)****Byte Hi = Proportional****R/W**

Function:

This parameter is the gain of the feed-back loop

Min/Max:

0 ÷ 255 (0 ÷ FF Hex)

Default:

VxI or V2 = 5 Hex

V or I = 12 Hex

Note:

This parameter increase the loop speed but decrease the loop stability.

## 14 Maintenance

### 14.1 Trouble Shooting

Small problems sometimes can be solved locally with the help of the below tab of trouble shooting. If you don't succeed, contact us or your nearest distributor

Symptom	Indication on front unit	Possible reasons of the symptom	Actions
Thyristor unit doesn't go in conduction with input signal	Green LED (Aux) is always light off	<ul style="list-style-type: none"> <li>No voltage auxiliary power</li> </ul>	<ul style="list-style-type: none"> <li>Give auxiliary voltage supply (see wiring diagram)</li> </ul>
	Green LED (Aux) light on Green LED (ON) light off	<ul style="list-style-type: none"> <li>No input signal</li> <li>Reversed polarities of input signal</li> <li>Reset contact is open</li> </ul>	<ul style="list-style-type: none"> <li>Provide to give input signal</li> <li>Reverse the input signal polarity</li> <li>Make link on reset terminals (see wiring diagram)</li> </ul>
	Green LED (Aux) light on Green LED (ON) light on	<ul style="list-style-type: none"> <li>Fuse failure</li> <li>Load failure</li> <li>Load connection interruption</li> <li>Thyristor faulty and always in open circuit</li> </ul> With HB option the yellow led (HB) is light on	<ul style="list-style-type: none"> <li>Substitute the fuse</li> <li>Check the load</li> <li>Check the wiring</li> <li>Substitute the faulty thyristor</li> </ul>
Load current flows also with no input signal	Green LED (ON) is always light off.	<ul style="list-style-type: none"> <li>Wrong wiring</li> <li>Short circuit on thyristor</li> </ul> If there is HB option the red LED (SC) is light on	<ul style="list-style-type: none"> <li>Check the load wiring</li> <li>Substitute the thyristor</li> </ul>
Current flows at nominal value but Yellow LED (HB) is light on	Yellow LED (HB) light on	<ul style="list-style-type: none"> <li>HB circuit not tuned</li> <li>Current transformers not properly wired</li> </ul>	<ul style="list-style-type: none"> <li>Make HB calibration procedure</li> <li>Control current transformers wiring</li> </ul>
Current flows at nominal value but Red LED (SC) is light on	Red LED (SC) light on	<ul style="list-style-type: none"> <li>HB circuit not tuned</li> </ul>	<ul style="list-style-type: none"> <li>Make HB calibration procedure</li> </ul>
Thyristor unit doesn't work properly		<ul style="list-style-type: none"> <li>Wrong input signal selection.</li> <li>Wrong input signal calibration (out of range).</li> <li>Auxiliary voltage supply out of limits</li> </ul>	<ul style="list-style-type: none"> <li>Control input signal setting.</li> <li>Repeat input calibration procedure.</li> <li>Verify the auxiliary voltage supply</li> </ul>

## 14.2 Fans

The thyristor unit with forced ventilation uses fans that rotate permanently when the unit is supplied. In case of accidental fan failure, there is an over heating temperature on heatsink. In this case to give protection to thyristor there is a thermal switch properly setted. The function of this switch is to open the input signal until the heatsink temperature falls below the setted value. This means that also with input signal in ON condition the unit is switched OFF and the system can not work at full power. For this reason is important to control periodically the fans status checking that are rotating.

## 14.3 Servicing

In order to have correct cooling, the user must clean the heatsink and the protective grill of the fans. The frequency of this servicing depends on environmental pollution. Also check periodically if the screw for the power cables and safety earth are tightened correctly.

## 14.4 Repairing procedure

- Phone to CD Automation.
- Explain to Service Engineer the problem because sometimes it can be solved with a phone call. If this is not possible, ship the unit to CD Automation or to your distributor.
- Write a fault description and give the name of your personnel to which refers.
- Use a rugged packaging to ship the unit.

## 14.5 Warranty condition

CD Automation gives a 12 months warranty to its products. The warranty is limited to repairing and parts substitution in our factory and does exclude products not properly used and fuses. Warranty does not include products with serial numbers deleted. The faulty product should be shipped to CD Automation at customer's cost and our Service will evaluate if product is under warranty terms.

Substituted parts remain of CD Automation property.

## 15 CD Automation's distributors

For a more precise and rapid service, please contact the distributor nearest to you:

ITALY	
<p><b>CABE S.r.l.</b> Via Ferrara, 15/17 40018 S. Pietro in Casale (BO) Tel: 051 6661345 Fax: 051 6661283 Sig. Bergonzoni <a href="mailto:info@cabesrl.it">info@cabesrl.it</a></p>	<p><b>Vectra Misure S.r.l.</b> Via Gaidano, 109/17 10137 Torino (TO) Tel: 011 3097003 Fax: 011 3098799 Sig. Cochis <a href="mailto:vectramisure@libero.it">vectramisure@libero.it</a></p>
<p><b>CEAM Control Equip. S.r.l.</b> Via Val d'Orme, 291 50053 Empoli (FI) Tel: 0571 924181 Fax: 0571 924505 Sig. Campinoti <a href="mailto:info@ceamgroup.it">info@ceamgroup.it</a></p>	<p><b>Secif S.a.s.</b> Via Bachelet, 27 35010 Busa di Vigonza (PD) Tel: 049 8934422 Fax: 049 8934415 Sig. Ferro <a href="mailto:info@secif.com">info@secif.com</a></p>
<p><b>Studio Rapaccini S.a.s.</b> Via del Rivo, 138 05100 Terni (TR) Tel: 0744 305105 Cell: 335 6163428 Fax: 0744 305110 Dott. Rapaccini <a href="mailto:rapaccin@tin.it">rapaccin@tin.it</a></p>	
INTERNATIONAL DISTRIBUTORS	
<p><b>PICS NV</b> Middelmolenaan, 110 2100 Deurne Belgium Tel: +32 332 65959 Fax: +32 332 66770 Mr. Berge Billiauws <a href="http://www.pics.be">http://www.pics.be</a></p>	<p><b>OY E Sarlin AB</b> PL-750 00101 Helsinki Finland Tel: +358 950444259 Fax: +358 95666951 Mr. Tapio Ala Ketola <a href="http://www.sarlin.com">http://www.sarlin.com</a></p>
<p><b>Hengstler Div. Cont. Ind.</b> 94-106 Rue B. Pascal Z.I. des Mardelles 93602 Aulnay Sous Bois Cedex France Tel: +33 148795541 Fax: +33 1498795561 Mr. Laurent Mulley</p>	<p><b>Mesa Industrie-Elektronik GmbH</b> Elbest., 10 45768 Marl Germany Tel: +49 2365915220 Fax: +49 2365915225 Mr. Peter Hallwas</p>
<p><b>Hengstler GmbH</b> Uhlandst, 49 D-78554 Aldingen Germany Tel: +49 7424890 Fax: +49 742489500 Mr. Armin Belle</p>	<p><b>Toshniwal Instruments Mfg Pvt Ltd</b> PO Gagwana Pin 305023 Dist. Ajmer India Tel: +91 145420506 Fax: +91 145420505 Mr. Ravi Toshniwal</p>

**CasCade Automation Systems BV**

Ridderhaven, 16  
 2984 BT Ridderkerk  
 The Netherlands  
 Tel: +31 180463870  
 Fax: +31 180485921  
 Mr. Patrick Braams  
<http://www.cascade-a-s.com>  
[mailer@cascade-a-s.com](mailto:mailer@cascade-a-s.com)

**Paragon Alliance Ltd**

PO Box 104 - Pevensey  
 BN23 5WZ - East Sussex  
 England  
 Tel: +44 1323740800  
 Fax: +44 1323740018  
 Mr. Jeremy Watson  
<http://www.paragonalliance.co.uk>  
[jez.watson@paragonalliance.co.uk](mailto:jez.watson@paragonalliance.co.uk)

**Teck Instrument AS**

Verksveien, 7  
 N-3330 Skotselv  
 Norway  
 Tel: +47 32 241300  
 Fax: +47 32 241301  
 Mr. Johan Petter Haffner  
<http://www.teck.no>  
[jph@teck.no](mailto:jph@teck.no)

**LA-Konsult AB**

Agatan, 1  
 73440 Hallstahammar  
 Sweden  
 Tel: +46 22010905  
 Fax: +46 22010403  
 Mr. Leif Johansson  
<http://www.la-konsult.se>  
[leif@la-konsult.se](mailto:leif@la-konsult.se)

**SRC Sistemas de Regulacion y Control, SL**

Avda. del Cantabrico, 11. Pabellon, 6  
 Poligono Industrial Betoño  
 01013 Vitoria-Gasteiz (Alava)  
 Spain  
 Tel: +34 945259455  
 Fax: +34 945258852  
[info@srsl.com](mailto:info@srsl.com)  
<http://www.srsl.com>

**CONTROLTEMP, SL**

C/ Rafael Casanovas, 21 local.  
 08130 Sta Perpetua de Mogoda  
 Barcelona  
 Spain  
 Tel: +34 935741320  
 Fax: +34 935744116  
[info@controltemp.net](mailto:info@controltemp.net)  
<http://www.controltemp.net>

**CRA - Mess-, Regel- + Antriebstechnik AG**

Stampfstrasse, 74  
 CH-8645 Jona  
 Switzerland  
 Tel: +41 552126959  
 Fax: +41 552126960  
 Mr. Chiauzzi  
<http://www.cra.ch>  
[mail@cra.ch](mailto:mail@cra.ch)

**Danaher Corporation**

1675 Delany Road  
 Gurnee, IL 60031-1282  
 USA  
 Tel: +1 8473605310  
 Fax: +1 8476626633  
 Mr. Andrew Ross  
<http://www.dancon.com>  
[andrew.ross@danaher.com](mailto:andrew.ross@danaher.com)

**Electronica Francisco Palma Saavedra**

Av. Amerigo Vespuccio 513-B  
 Villa Alto Jahuel, 2 - Pudahuel - Santiago  
 Chili  
 Tel: +56 27482023  
 Fax: +56 27482032  
 Mr. Francisco Palma S.  
[electronica-palma.s@electronicapalma.cl](mailto:electronica-palma.s@electronicapalma.cl)

**Beta Technic Aps**

Bygstubben, 5  
 DK - 2950 Vedbaek  
 Denmark  
 Tel: +45 45662208  
 Fax: +45 45662206  
 Sune Granzow  
<http://www.betatechnic.dk>

**Bresimar LDA**

Quinta Do Simao en 109 Esgueira  
 997 Aveiro  
 Portugal  
 Tel: +351 214951760  
 Fax: +351 234303329  
 Mr. Carlos Breda

## 16 Note

[Redacted content]