



WEIDER PRO 9930

Patent Pending

Model No. 831.159720
Serial No. _____

The serial number is found in the location shown below. Write the serial number in the space above.

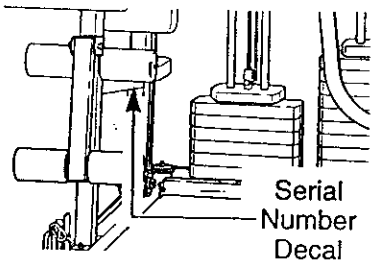

Serial
Number
Decal

EXERCISE
EQUIPMENT

QUESTIONS

HELPLINE!

1-800-736-6879

SEARS, ROEBUCK AND CO.
HOFFMAN ESTATES, IL 60179

CAUTION

Read all precautions and instructions in this manual before using this equipment. Save this manual for future reference.

USER'S MANUAL

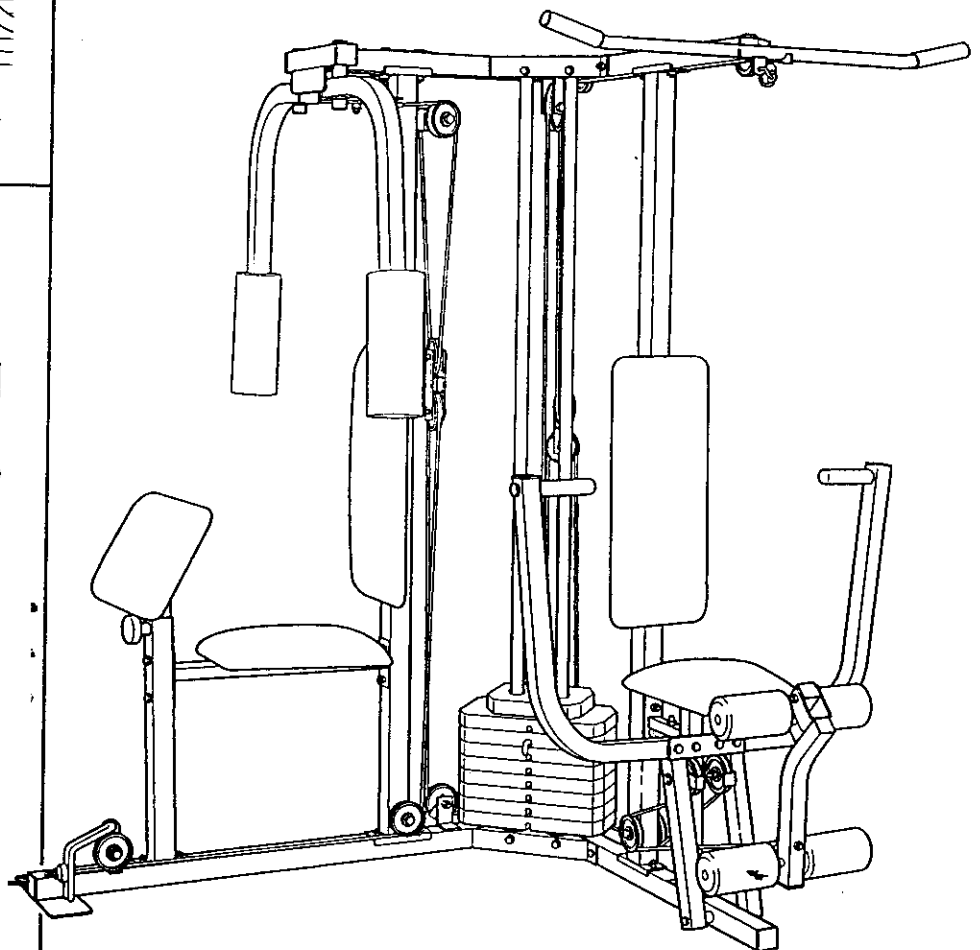

Visit our website at

www.weiderfitness.com

*new products, prizes,
fitness tips, and much more!*

Table of Contents

Important Precautions	3
Before You Begin	4
Assembly	5
Cable Diagrams	19
Adjustment	21
Trouble-shooting and Maintenance	22
Weight Resistance Chart	23
Ordering Replacement Parts	Back Cover
Full 90-day Warranty	Back Cover

Note: A PART LIST/EXPLODED DRAWING and a PART IDENTIFICATION CHART are attached in the center of this manual. Remove the PART LIST/EXPLODED DRAWING and the PART IDENTIFICATION CHART before beginning assembly.

Important Precautions

⚠ WARNING: To reduce the risk of serious injury, read the following important precautions before using the home gym.

1. It is the responsibility of the owner to ensure that all users of the home gym are adequately informed of all precautions.
2. Read all instructions in this manual and in the accompanying literature before using the home gym.
3. If you feel pain or dizziness at any time while exercising, stop immediately and begin cooling down.
4. Use the home gym only on a level surface. Cover the floor or carpet beneath the home gym for protection.
5. Inspect and tighten all parts often. Replace any worn parts immediately.
6. Make sure the cables remain on the pulleys at all times. If the cables bind while you are exercising, stop immediately and make sure the cables are on all of the pulleys.
7. Always stand on a foot plate when performing an exercise that could cause the home gym to tip.
8. Keep hands and feet away from moving parts.
9. Keep children under the age of 12 and pets away from the home gym at all times.
10. Always wear athletic shoes for foot protection when exercising.
11. Never release the press arms, butterfly arms, leg lever, lat bar or nylon strap while weights are raised. The weights will fall with great force.
12. Always disconnect the lat bar or nylon strap from the home gym when performing an exercise that does not use the attachments.
13. The home gym is intended for home use only. Do not use the home gym in a commercial, rental or institutional setting.
14. Important: The warning decals shown below have been attached to the home gym in the locations shown. If a decal is missing or illegible, please call our customer HELPLINE at the number on the front cover of this manual to order a free replacement decal. Apply the new decal in the appropriate location.

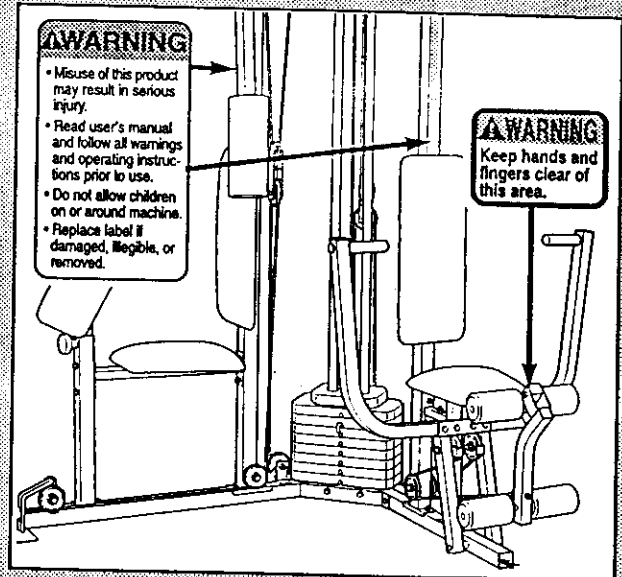

WARNING: Before beginning this or any exercise program, consult your physician. This is especially important for persons over the age of 35 or persons with pre-existing health problems. Read all instructions before using. SEARS assumes no responsibility for personal injury or property damage sustained by or through the use of this product.

Before You Begin

Thank you for selecting the innovative and versatile WEIDER® PRO 9930 Home Gym. The WEIDER® PRO 9930 offers a unique selection of weight stations designed to develop every major muscle group of the body. Whether your goal is to tone your body, build dramatic muscle size and strength or improve your cardiovascular system, the WEIDER® PRO 9930 will help you to achieve the results you want.

For your benefit, read this manual carefully before using the WEIDER® PRO 9930 Home Gym. If you have additional questions, please call our toll-free

HELPLINE at 1-800-736-6879, Monday through Saturday, 7 a.m. until 7 p.m. Central Time (excluding holidays). To help us assist you, please note the product model number and serial number before calling. The model number is 831.159720. The serial number can be found on a decal attached to the WEIDER® PRO 9930 Home Gym (see the front cover of this manual).

Please use the drawing below to familiarize yourself with the major parts and how they fit together.

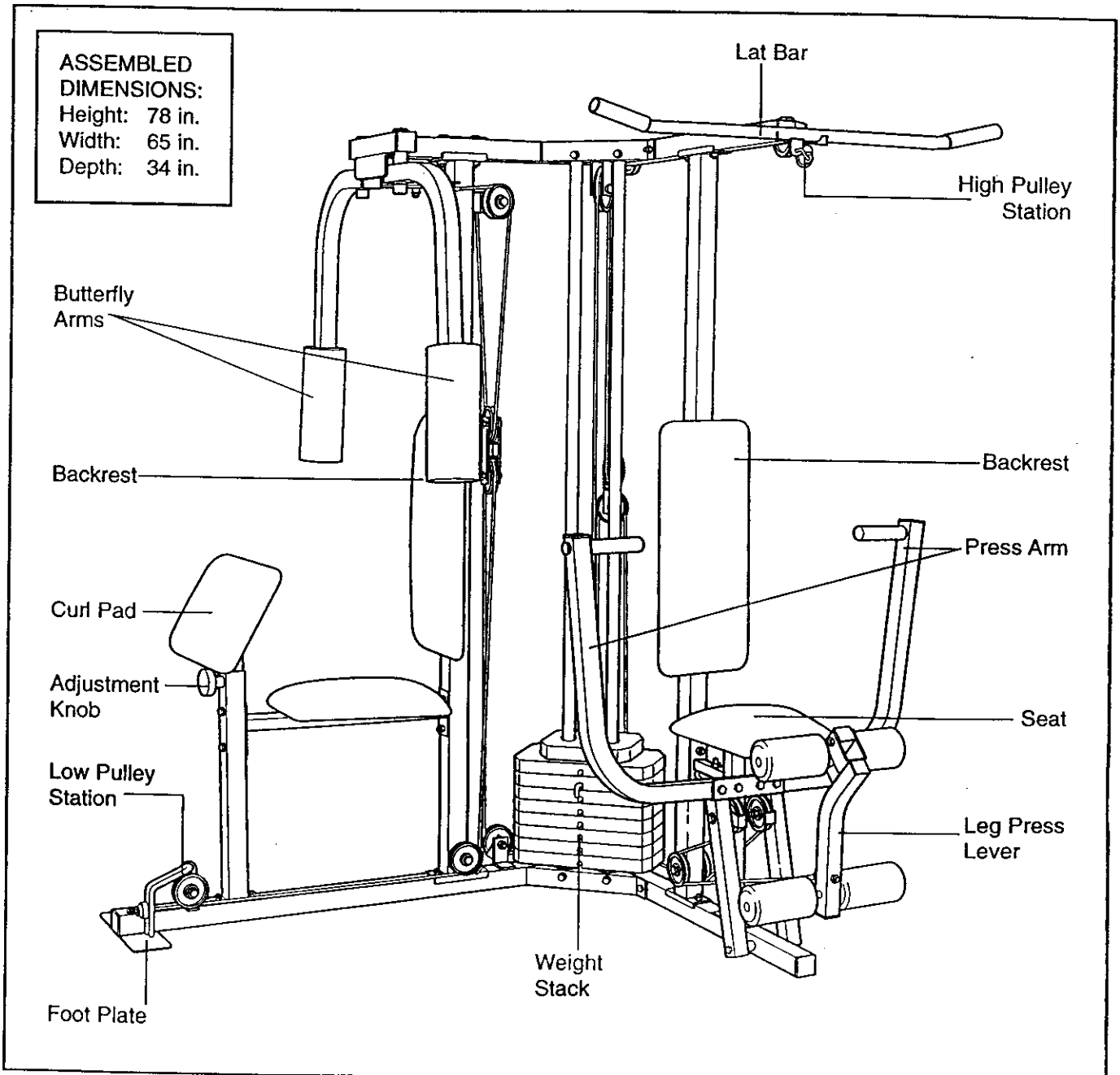

Assembly

Note: This introduction will save you more time than it takes to read it!

Making Things Easier for Yourself

Everything in this manual is designed to ensure that our products can be assembled successfully by anyone. However, it is important to realize that your new equipment is a sophisticated product with many small parts. The assembly process will take time—possibly several hours. Most people find that by setting aside plenty of time, and by deciding to make the task enjoyable, assembly will go smoothly. You may want to complete the process over a couple of evenings.

Some assembly steps require two people.

Giving Yourself a Good Start

Before you begin the assembly process itself, take the time to complete the steps outlined here.

Clearing the Workspace

Clear a workspace that is large enough to hold all parts and allow you to walk all the way around the assembled equipment.

Unpacking the Box

To make the assembly process as smooth as possible, we have broken it into separate stages. All parts used in each stage are found in individual packages in the shipping box. Place all parts in a cleared area and remove the packing materials. Do not dispose of the packing materials until assembly is completed.

Important: Wait until you begin each assembly stage to open the parts bag labeled for that assembly stage.

Identifying Parts

To help you identify the small parts used in assembly, we have included a PART IDENTIFICATION CHART located in the center of this manual. Place the chart on the floor or work table and use it to quickly identify different parts for each step. Note: Some small parts may have been pre-attached for shipping. If a part is not in the parts bag, check to see if it has been pre-attached.

Orienting Parts





As you assemble this product, be sure that all parts are oriented as shown in the drawings.

Tightening Parts

Tighten all parts as you assemble them, unless instructed to do otherwise.

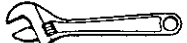
Lining Up the Tools

Assembly requires the following tools (not included):

- Two (2) adjustable wrenches 
- One (1) standard screwdriver 
- One (1) phillips screwdriver 
- One (1) rubber mallet 
- Lubricant, such as grease or petroleum jelly, and soapy water
- Tape, such as clear tape or masking tape

Assembly will be more convenient if you have a socket set, a set of open-end or closed-end wrenches or a set of ratchet wrenches.

The Four Stages of the Assembly Process

Frame Assembly

You will begin by assembling the base and the upright frames that serve as the skeleton of the equipment.

Arm Assembly

This assembly completes the press and butterfly arms that you operate while you are exercising.

Cable Assembly

This assembly completes the cables and pulleys that connect the moving arms with each other and with the weights.

Seat Assembly

This assembly completes the seat and backrest that support your body while you are exercising.

Frame Assembly

1. Before beginning, make sure that you have read and understood the information on page 5.

Locate and open the parts bag labeled "FRAME ASSEMBLY."

Press a 2" Square Inner Cap (38) into the Butterfly Base (61). Press two 2" Square Inner Caps (38) into the Press Base (60).

Insert four 5/16" x 2 1/2" Carriage Bolts (1) up through the indicated holes in the Butterfly Base (61) and the Press Base (60). **Note: If the Bolts fall out, secure them by putting a small piece of tape over the head of each Bolt.** Place the Butterfly Base and Press Base flat on the floor.

Attach the Press Base (60) to the Butterfly Base (61) with two 5/16" x 2 1/2" Bolts (3), two 5/16" Flat Washers (19), and two 5/16" Nylon Locknuts (2).

2. Position the Butterfly Upright (62) as shown. Place the bracket on the lower end of the Butterfly Upright (62) over the indicated 5/16" x 2 1/2" Carriage Bolts (1) in the Butterfly Base (61). Hand tighten two 5/16" Nylon Locknuts (2) onto the Bolts. **Do not tighten the Nylon Locknuts yet.**

Place the bracket on the lower end of the Press Frame Upright (59) over the indicated 5/16" x 2 1/2" Carriage Bolts (1) in the Press Base (60). Hand tighten two 5/16" Nylon Locknuts (2) onto the Bolts. **Do not tighten the Nylon Locknuts yet.**

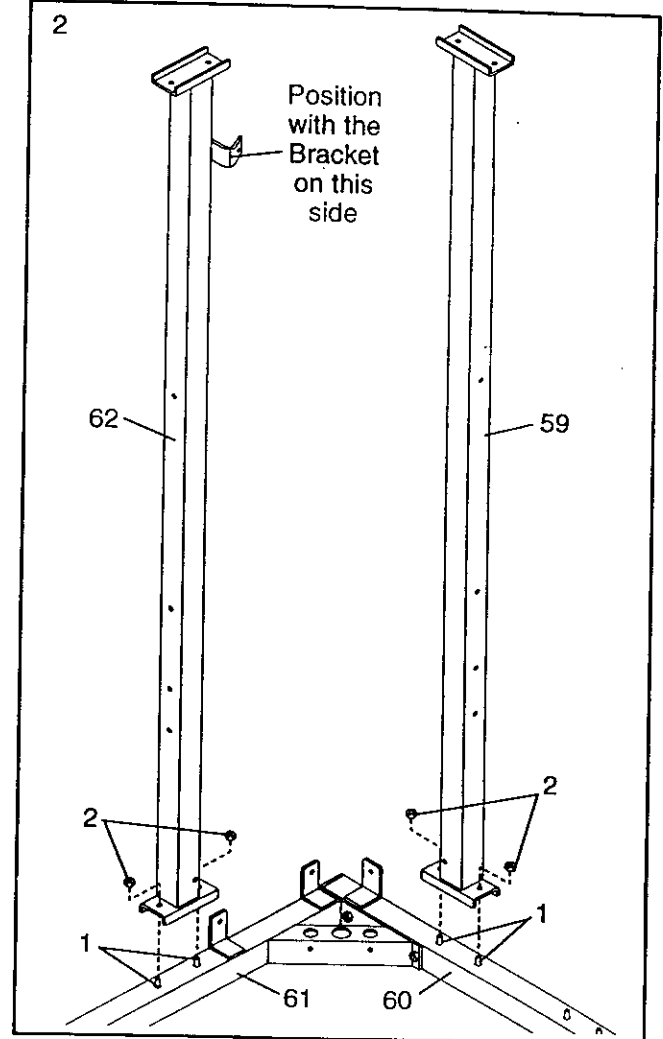
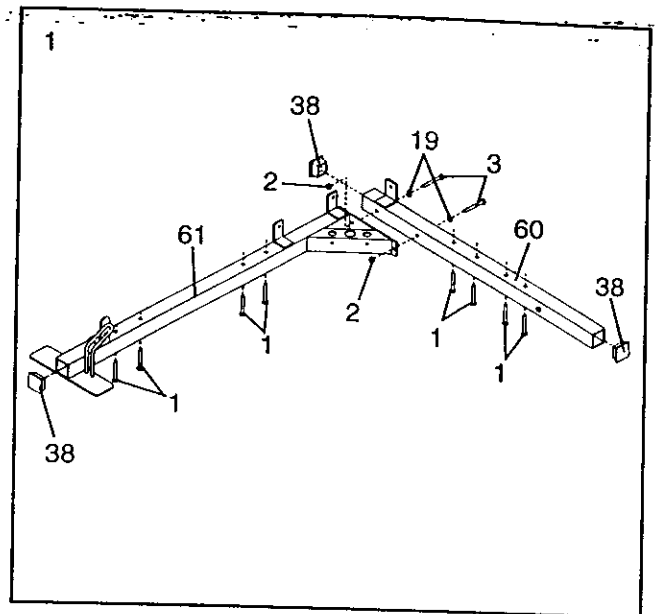

- Place two Weight Bumpers (84) over the indicated holes in the Butterfly Base (61). Slide the Weight Guides (58) into the indicated holes.

Attach the Weight Guides (58) to the Butterfly Base (61) with two 3/8" x 2 1/2" Bolts (6), four 3/8" Flat Washers (17), and two 3/8" Jam Nuts (18).

Slide the eight Weights (8) onto the Weight Guides (58). **Make sure the Weights are turned so the pin grooves are on the bottom of the weights.**

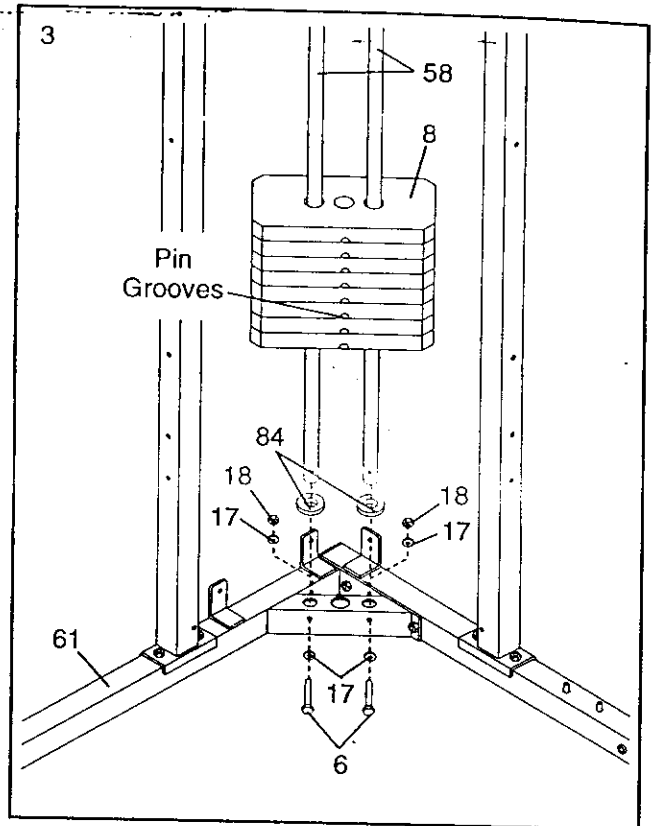

- Press a Weight Tube Bumper (76) into the lower end of the Weight Tube (77). Slide the Weight Tube into the center hole in the Weights (8).

Lubricate the holes in the Top Weight (78). Slide the Top Weight onto the Weight Guides (58).

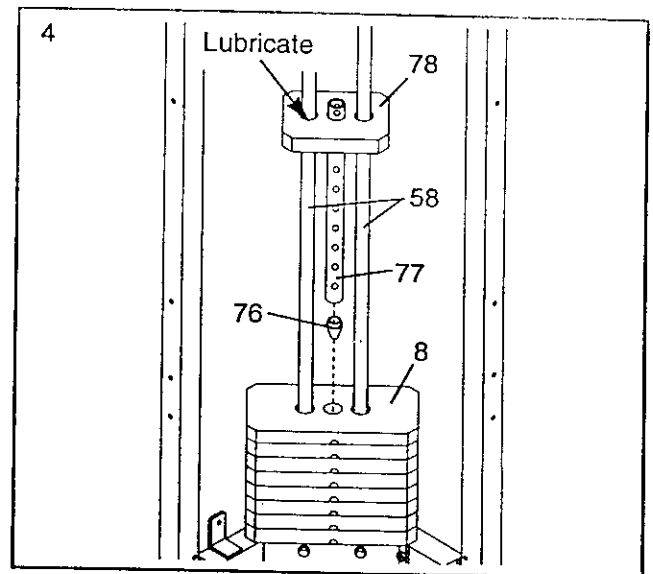

- Press a 2" Square Inner Cap (38) into the Butterfly Top Frame (64). Press two 1" Round Inner Caps (41) into the top of the Butterfly Top Frame.

Attach the Butterfly Top Frame (64) to the Press Top Frame (63) with two 5/16" x 2 1/2" Bolts (3), two 5/16" Flat Washers (19), and two 5/16" Nylon Locknuts (2).

Press a 2" Square Inner Caps (38) into the end of the Press Top Frame (63).

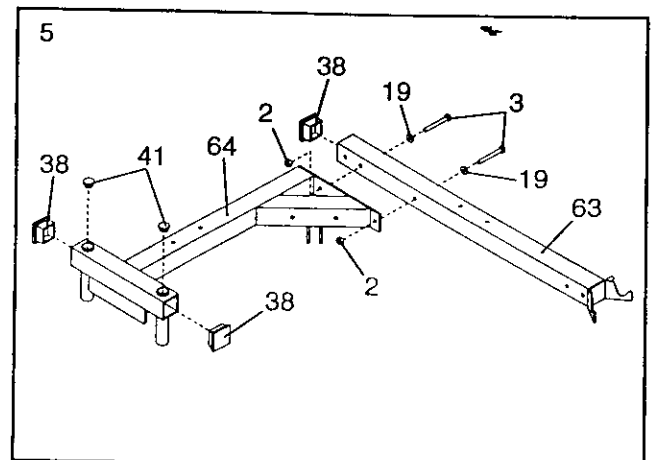

6. Hold the Butterfly Top Frame (64) and the Press Top Frame (63) on the indicated brackets on the Uprights (59, 62) and the Weight Guides (58). **Note: Before attaching the Top Frames to the Uprights, make sure that both Weight Guides (58) are positioned inside of the indicated holes.**

Attach the Butterfly Top Frame (64) and the Press Top Frame (63) to the Uprights (59, 62) and Weight Guides (58) with four 5/16" x 2 3/4" Bolts (20), two Top Plates (46), and four 5/16" Nylon Locknuts (2). **Do not tighten the Nylon Locknuts yet.**

Secure the Weight Guides (58) to the Butterfly Top Frame (64) and to the Press Top Frame (63) with two 3/8" x 2 1/2" Bolts (6), four 3/8" Flat Washers (17), and two 3/8" Jam Nuts (18).

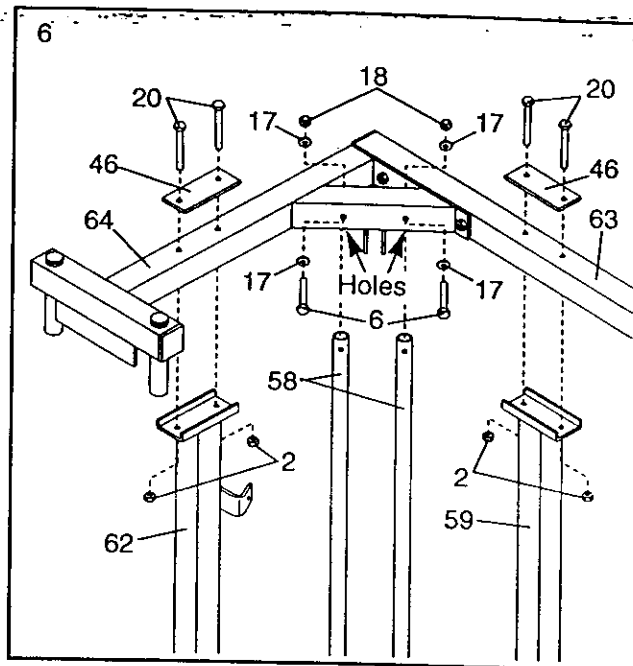

7. Turn the Seat Brace (75) so the nut is on the side as shown. Attach the Seat Brace (75) to the Butterfly Base (61) with the 5/16" x 2 1/2" Carriage Bolts (1) and two 5/16" Nylon Locknuts (2). **Do not tighten the Nylon Locknuts yet.**

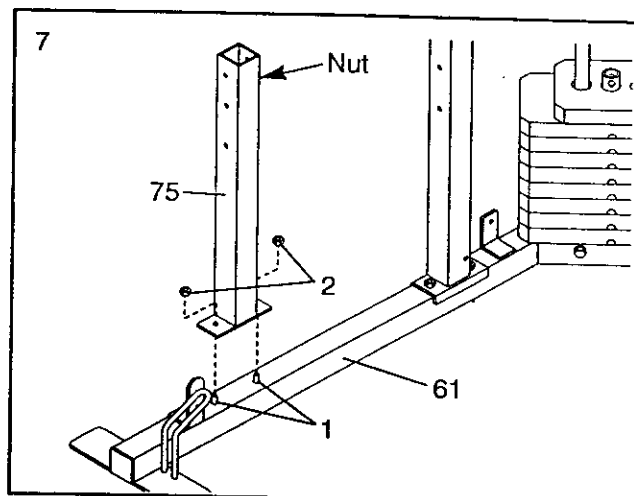

8. Hold the Seat Bar (74) between the Seat Brace (75) and the Butterfly Upright (62) so that the hole that is closest to the welded plate is facing the Seat Brace. Attach the Seat Bar (74) to the Seat Brace (75) with two 5/16" x 2 1/2" Bolts (3), two 5/16" Flat Washers (19), and two 5/16" Nylon Locknuts (2). **Do not overtighten the Bolts or the Curl Post attached in step 38 will not slide freely. Do not tighten the Nylon Locknuts yet.**

Attach the Seat Bar (74) to the Butterfly Upright (62) with two 5/16" x 2 1/2" Bolts (3), two 5/16" Flat Washers (19), and two 5/16" Nylon Locknuts (2).

Important: Go back and tighten all of the Nylon Locknuts used in steps 1 through 8.

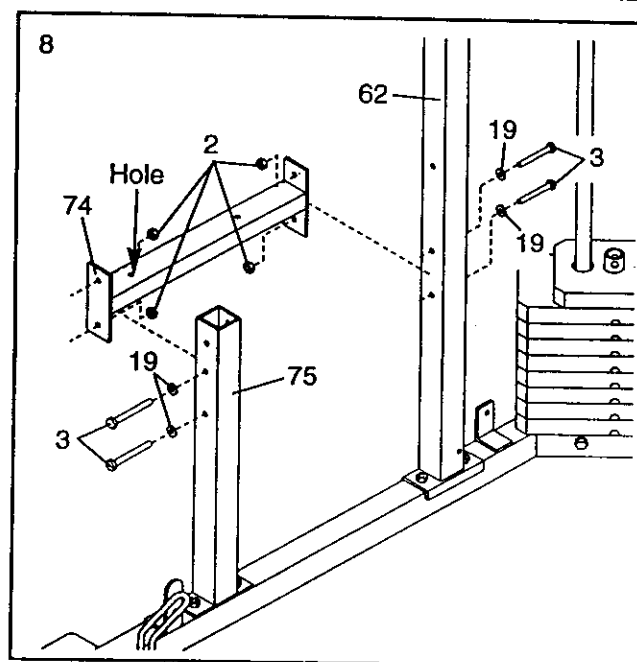

Arm Assembly

9. Locate and open the parts bag labeled "ARM ASSEMBLY."

See the inset drawing. Orient the Press Frame (53) as shown. Lubricate a 3/8" x 8" Bolt (30). Attach the Press Frame to the Press Base (60) with the 3/8" x 8" Bolt, two 1" x 7/8" Plastic Bushings (29), and one 3/8" Nylon Locknut (4). **Do not overtighten the 3/8" Nylon Locknut. The Press Frame must pivot easily.**

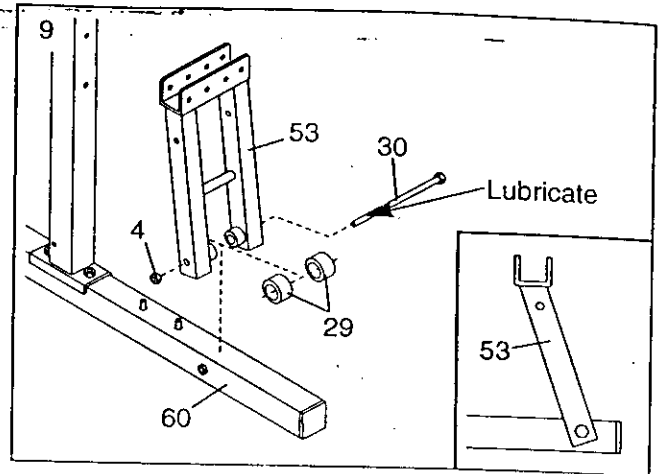

10. Press a 1 3/4" Square Inner Cap (37) into the top of a Press Arm (54). Press a 1" Inner Cap (80) into the indicated hole in the Press Arm.

Attach the Press Arm (54) to the bracket on the Press Frame (53) with two 5/16" x 2 1/2" Bolts (3) and two 5/16" Nylon Locknuts (2).

Repeat this step to assemble the second Press Arm (54).

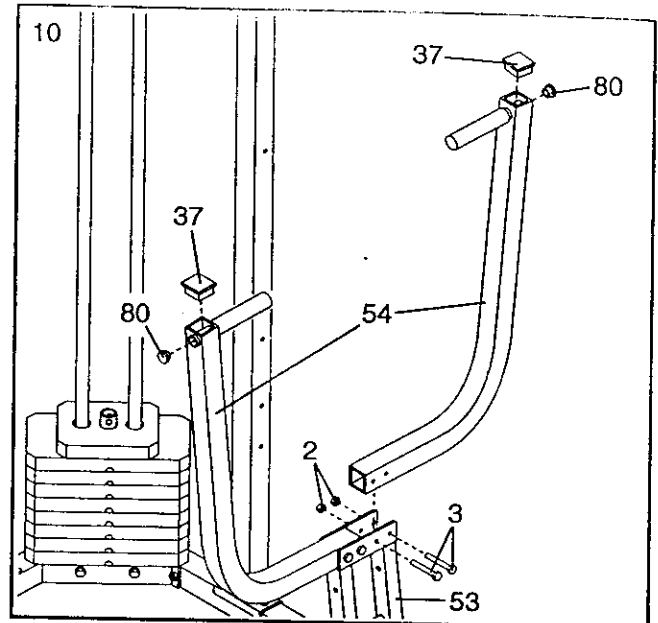

11. Press a 1 1/2" Inner Cap (79) into the Press Seat Frame (52).

Slide the bracket on the Press Seat Frame (52) onto the indicated 5/16" x 2 1/2" Carriage Bolts (1) in the Press Base (60). Tighten two 5/16" Nylon Locknuts (2) onto the Bolts.

Attach the Press Seat Frame (52) to the Press Frame Upright (59) with two 5/16" x 2 3/4" Bolts (20), two 5/16" Flat Washers (19), and two 5/16" Nylon Locknuts (2).

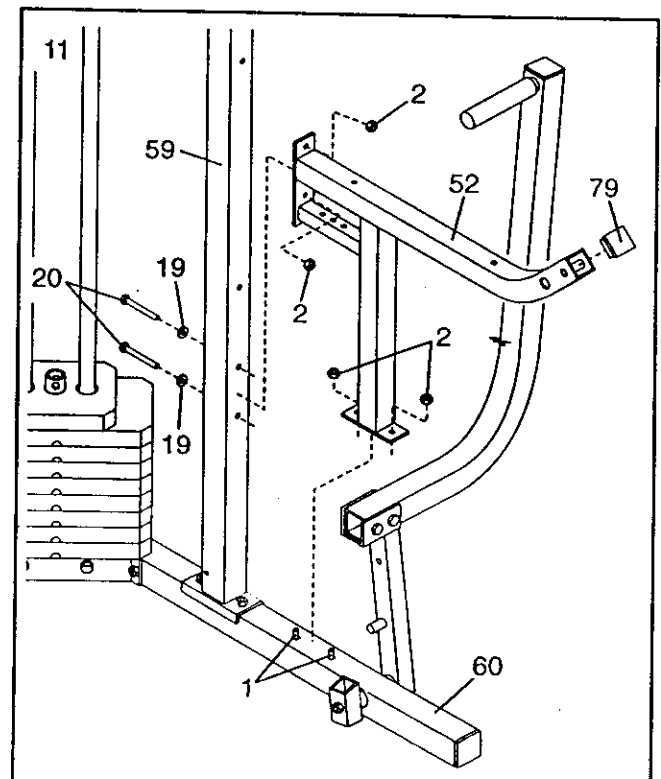

12. Press two 1 1/2" Square Inner Caps (79) into the Leg Lever (49).

Insert a Bumper (33) between the brackets on the Leg Lever (49). Secure the Bumper to the Leg Lever with a #10 x 1" Screw (32).

Slide the bracket on the Leg Lever (49) onto the Press Seat Frame (52). Attach the Leg Lever to the Press Seat Frame with a 5/16" x 2 1/4" Bolt (81) and a 5/16" Jam Nut (90). **Do not overtighten the 5/16" Jam Nut. It must be easy for the Leg Lever to pivot.**

Attach a 3/8" x 2 1/2" Eye Bolt (83) to the Leg Lever (49) with a 3/8" Flat Washer (17) and a 3/8" Nylon Locknut

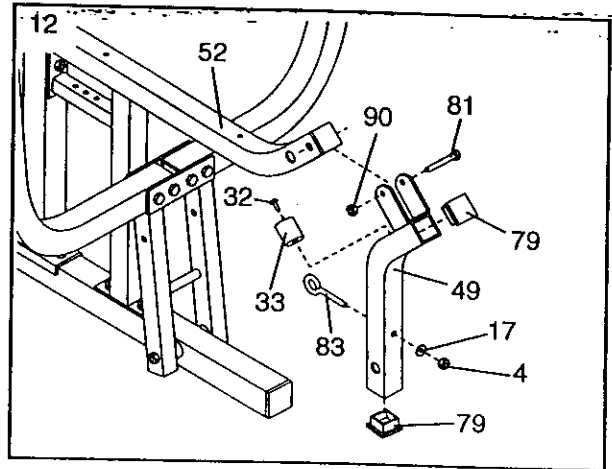

13. Press a 1 3/4" Square Inner Cap (37) into each end of the Right Butterfly Arm (68). Wet the lower end of the Arm with soapy water. Slide a 10" Pad (65) onto the lower end of the Arm.

Lubricate the indicated axle on the Butterfly Top Frame (64). Orient the Right Butterfly Arm (68) as shown and slide it onto the axle. Secure the Butterfly Arm with two 1" Retainers (25) and a 1" Round Cap (26). **Note: Place the Retainer Rings on top of the inverted Round Cap and gently tap the Cap onto the axle with a hammer. Make sure the teeth on the Retainer Rings bend towards the Cap as shown in the inset drawing.**

Repeat this step to assemble the Left Butterfly Arm (67).

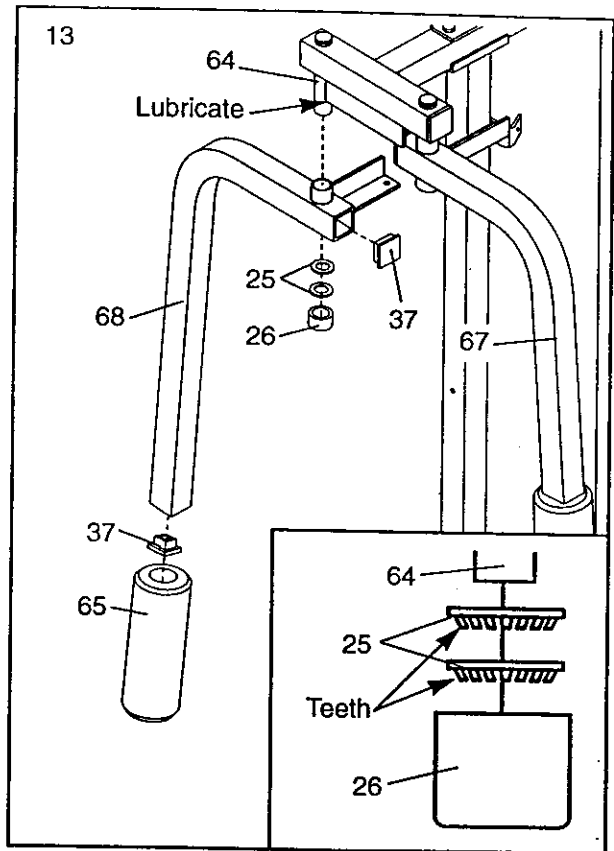

Cable Assembly

14. Locate and open the parts bag labeled "CABLE ASSEMBLY AND PULLEYS." For Cable Identification and routing during steps 14 to 32, refer to the Cable Diagrams and Cable ID Chart on pages 19 and 20.

Insert two 3/8" x 1" Bolts (15) into the welded brackets on the Left and Right Butterfly Arms (67, 68). Secure the Bolts with a 3/8" Jam Nut (18).

Identify the Short Cable (71). It is approximately 74 1/2" long and it has a closed loop on one end. Slide one end of the cable onto each of the 3/8" x 1" Bolts (15). Secure the Cable to the Bolts with 3/8" Jam Nuts (18). **Do not overtighten the Nylon Jam Nuts.**

Remove both 3 1/2" Pulleys (5) from the pre-assembled Adjustable Pulley Plates (44). Wrap the Short Cable (71) around a 3 1/2" Pulley (5) in the direction shown. Attach the 3 1/2" Pulley and a Cable Trap (39) to the top hole in the two Adjustable Pulley Plates (44) with a 3/8" x 2" Bolt (35) and a 3/8" Nylon Locknut (4). **Make sure the Cable Trap and Pulley Plates are oriented as shown.**

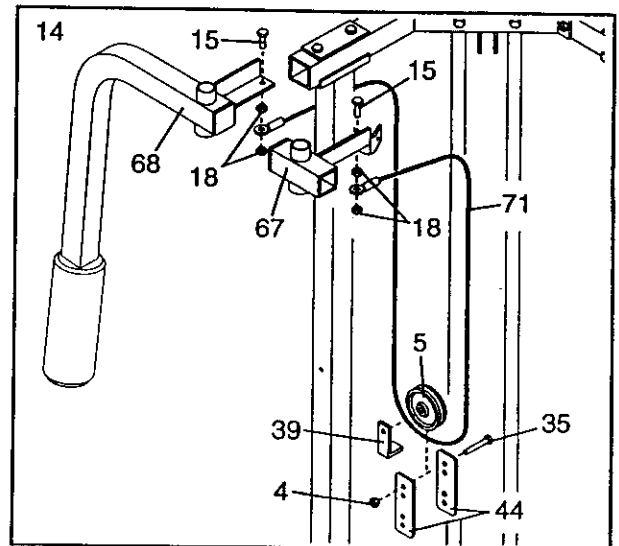

15. Wrap the Short Cable over a "V" Pulley (21) as shown. Attach the "V" Pulley and a Long Cable Trap (14) to one side of the welded bracket on the Butterfly Upright (62) with a 3/8" x 2 1/2" Bolt (6) and a 3/8" Nylon Locknut (4).

Attach another "V" Pulley (21) and a Long Cable Trap (14) to the other side of the welded bracket on the Butterfly Upright (62) in the same manner.

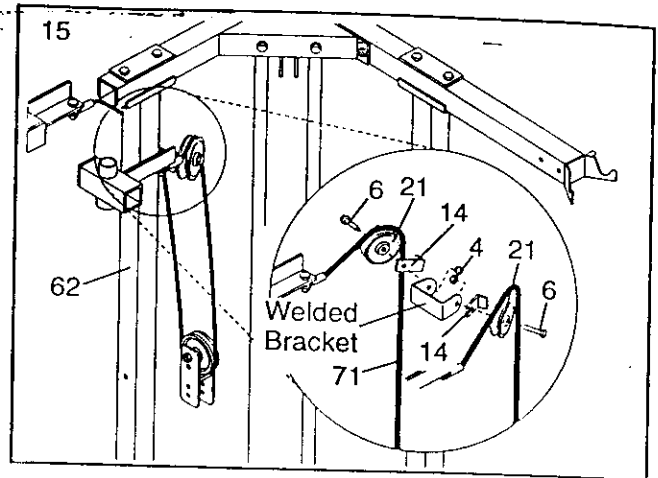

16. Identify the Medium Cable (72). It is approximately 140" long and it has a ball on one end and a threaded shaft on the other. Wrap the Medium Cable over the 3 1/2" Pulley (5) as shown. Attach the Pulley to the Press Top Frame (63) with a 3/8" x 3 1/2" Bolt (24), one 3/8" Flat Washer (17), and a 3/8" Jam Nut (18).

Make sure the Medium Cable (72) is between the 3 1/2" Pulley (5) and the welded pin on the Press Top Frame (63).

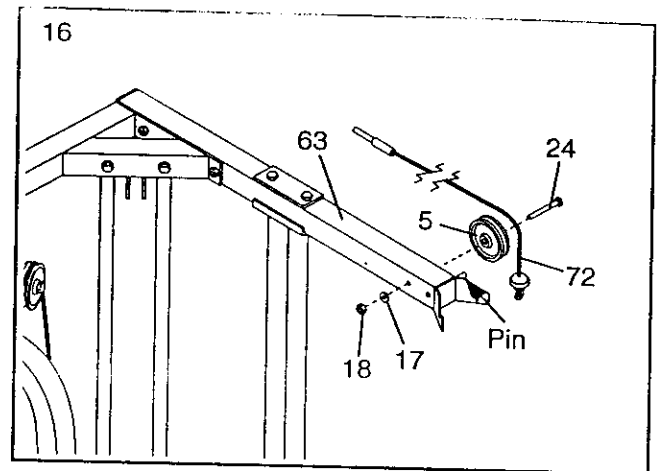

17. Wrap the Medium Cable (72) over a 3 1/2" Pulley (5) as shown. Attach the 3 1/2" Pulley and a Cable Trap (39) to the Press Top Frame (63) with one 3/8" x 3 3/4" Bolt (7).

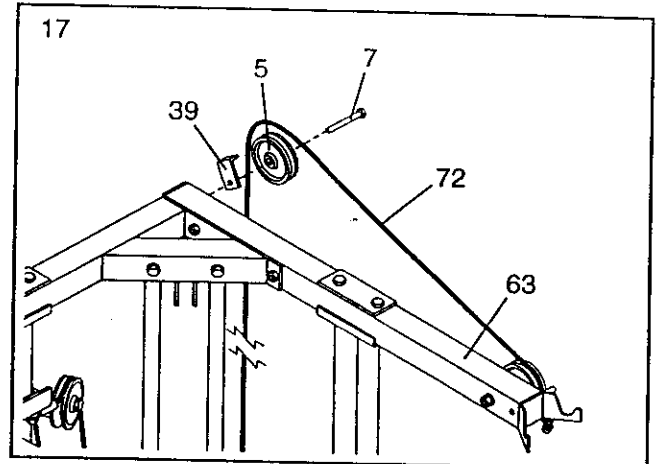

18. Route the threaded shaft on the Medium Cable (72) under one of the 3 1/2" Pulleys (5) that is already mounted in the Double "U" Bracket (36). Tighten the 3/8" x 1 3/4" Bolt (22).

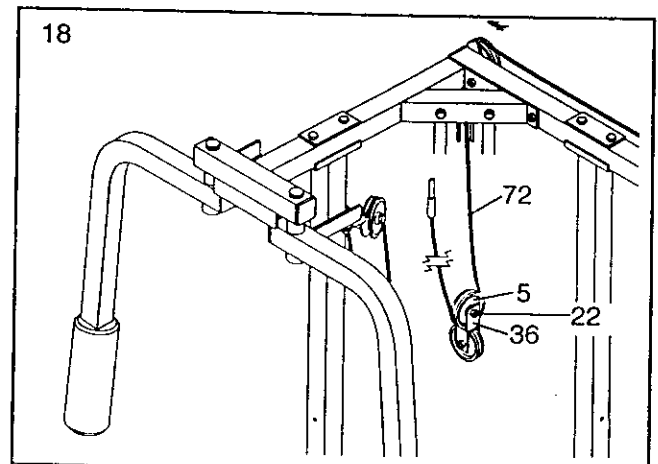

19. Wrap the Medium Cable (72) over a 4 1/2" Pulley (34) in the direction shown. Attach the Pulley to the Butterfly Top Frame (64) with a 3/8" x 1 3/4" Bolt (22) and a 3/8" Nylon Locknut (4).

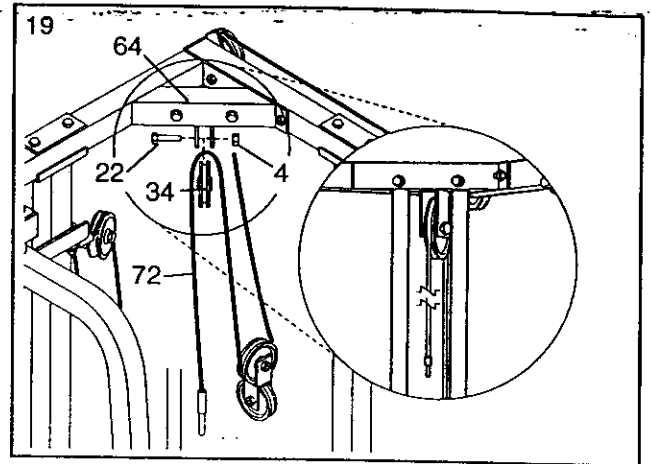

20. Attach the threaded shaft on the Medium Cable (72) to the Small "U"-Bracket (43) with a 1/4" Flat Washer (11) and a 1/4" Nylon Locknut (16). **Note: See the inset drawing. Do not completely tighten the Nylon Locknut; it should be threaded only two turns onto the end of the Cable.**

Attach the Small "U"-Bracket (43) to the hole in the Weight Tube (77) with a 5/16" x 1 3/4" Bolt (9), and a 5/16" Nylon Locknut (2).

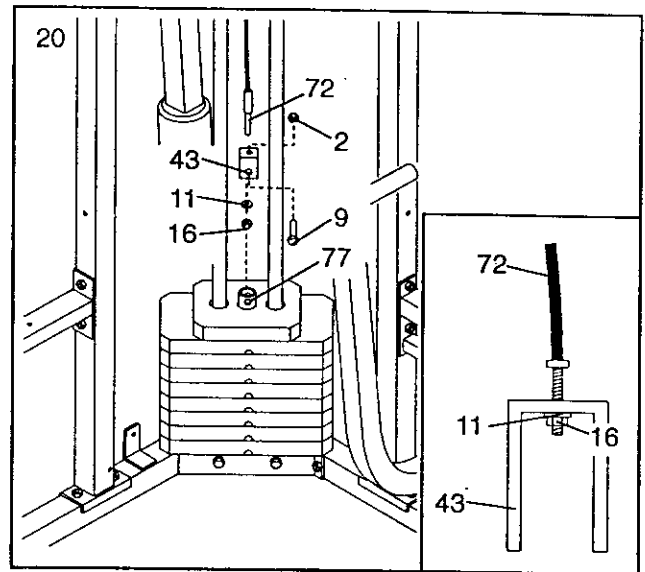

21. Identify the Long Cable (73). It is approximately 299.25" long and it has a ball on one end and a loop on the other. Route the end with the loop through the slot in the cable guide on the Butterfly Base (61).

Route the Long Cable (73) under a 3 1/2" Pulley (5) as shown. Attach the Pulley and a Cable Trap (39) to the indicated bracket on the Butterfly Base (61) with a 3/8" x 2" Bolt (35) and a 3/8" Nylon Locknut (4). **Make sure the Cable Trap is oriented as shown.**

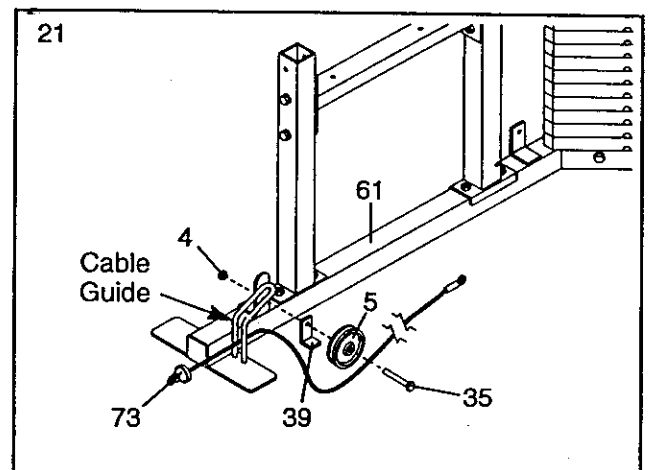

22. Wrap the Long Cable (73) around a 3 1/2" Pulley (5) in the direction shown. Attach the Pulley and a Cable Trap (39) to the Butterfly Upright (62) with a 3/8" x 3 3/4" Bolt (7), a 3/8" Flat Washer (17) and a 3/8" Nylon Locknut (4). Make sure the Cable Trap is oriented as shown.

Wrap the Long Cable (73) over a 3 1/2" Pulley (5) in the direction shown. Re-attach the Pulley and a Cable Trap (39) to the lower hole in the Adjustable Pulley Plates (44) with a 3/8" x 2" Bolt (35) and a 3/8" Nylon Locknut (4). Make sure the Cable Trap is oriented as shown.

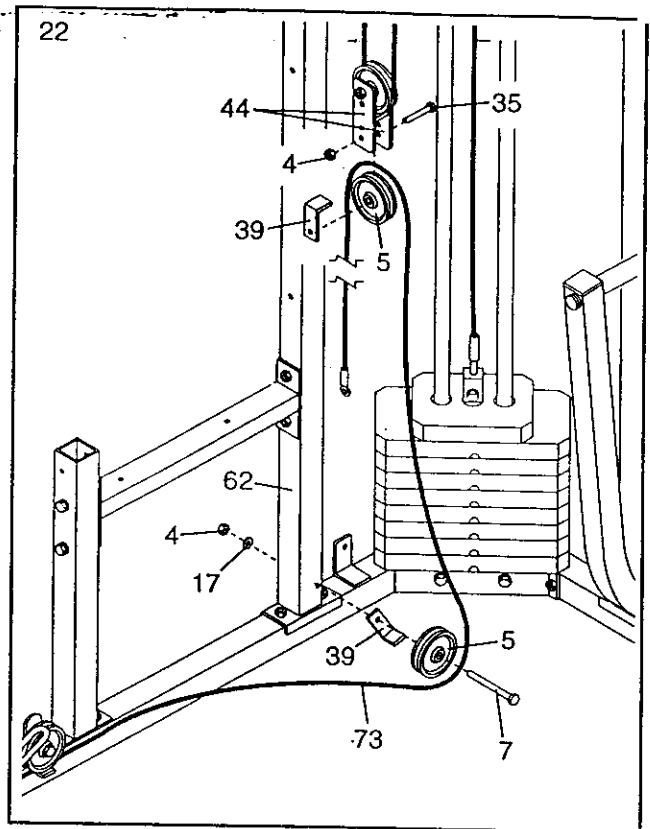

23. Wrap the Long Cable (73) around a 3 1/2" Pulley (5) in the direction shown. Attach the Pulley and a Cable Trap (39) to the indicated bracket on the Butterfly Base (61) with a 3/8" x 2" Bolt (35) and a 3/8" Nylon Locknut (4).

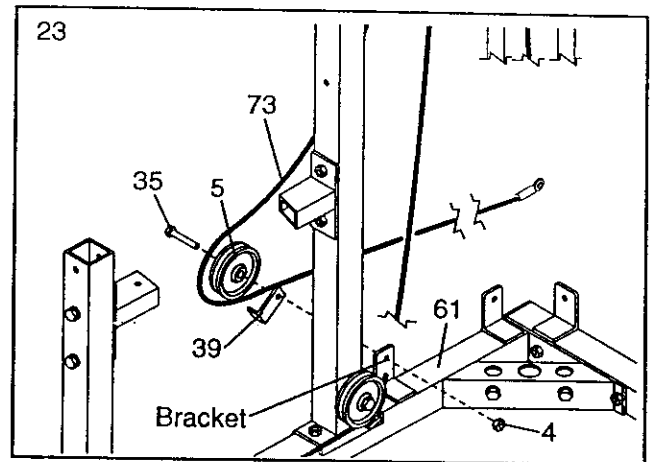

24. Wrap the Long Cable (73) around a 3 1/2" Pulley (5). Attach the Pulley and a Cable Trap (39) to the indicated bracket on the Butterfly Base (61) with a 3/8" x 2" Bolt (35) and a 3/8" Nylon Locknut (4).

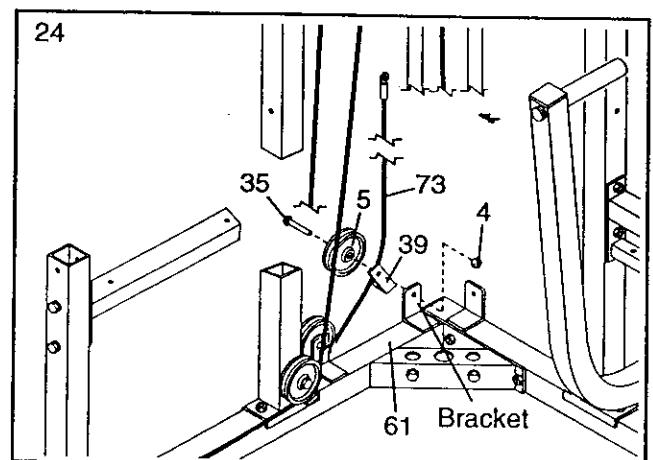

25. **Note:** For clarity, this and the following drawings show some parts removed.

Remove the lower 3 1/2" Pulley (5) from the Double "U" Bracket (36). Then, wrap the Long Cable (73) over the Pulley (5) in the direction shown. Attach the Pulley to the Double "U" Bracket (36) with a 3/8" x 1 3/4" Bolt (22) and a 3/8" Nylon Locknut (4). Make sure the Double "U" Bracket is oriented as shown.

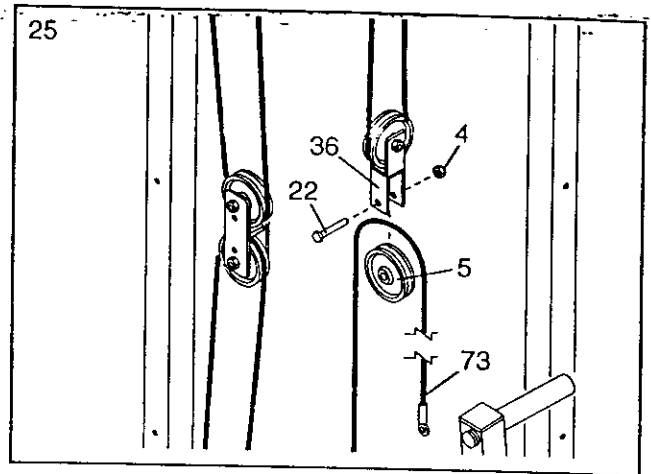

26. Wrap the Long Cable (73) around a 3 1/2" Pulley (5) in the direction shown. Attach the Pulley and a Cable Trap (39) to the indicated bracket on the Press Base (60) with a 3/8" x 2" Bolt (35) and a 3/8" Nylon Locknut (4). Make sure the Cable Trap is oriented as shown.

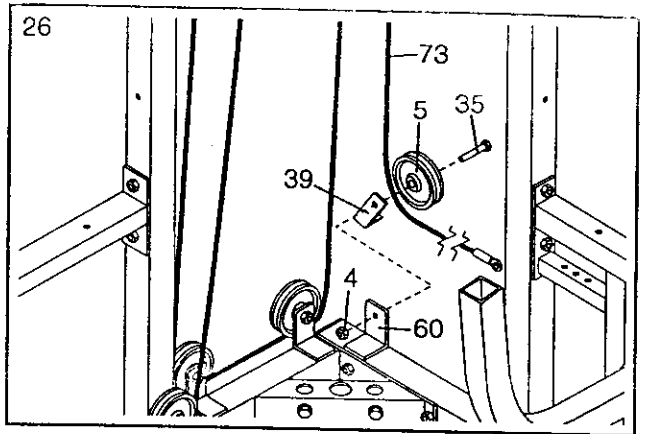

27. Attach a 3 1/2" Pulley (5) and a Cable Trap (39) to the Press Frame Upright (59) with a 3/8" x 4 3/4" Bolt (23).

Wrap the Long Cable (73) around the 3 1/2" Pulley (5) in the direction shown. Hand tighten a 3/8" Nylon Locknut (4) two turns onto the 3/8" x 4 3/4" Bolt. In step 31, another Pulley will be attached to the Bolt.

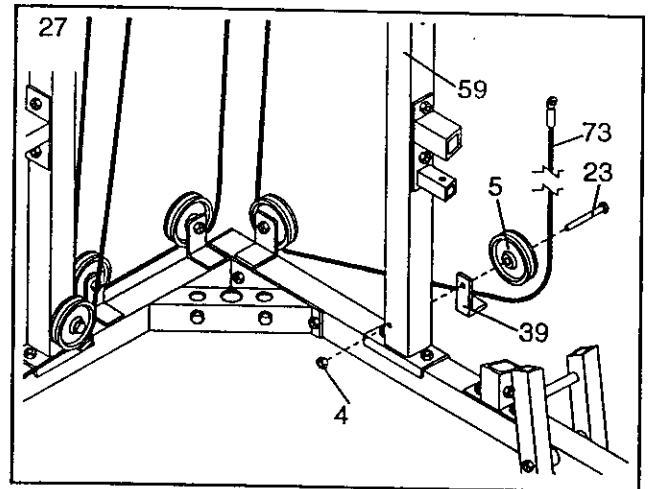

28. Route the Long Cable (73) through the opening in the Press Frame (53) and wrap the Long Cable around a 3 1/2" Pulley (5) in the direction shown. Then, route the Long Cable back through the opening in the Press Frame.

Attach the 3 1/2" Pulley (5) and a Cable Trap (39) to the indicated hole in the Press Frame (53) with a 3/8" x 3 1/4" Bolt (28), a 3/8" Flat Washer (17), and a 3/8" Nylon Locknut (4). Make sure the Pulley is mounted on the inside of the Press Frame (53). Make sure the Cable Trap is oriented as shown.

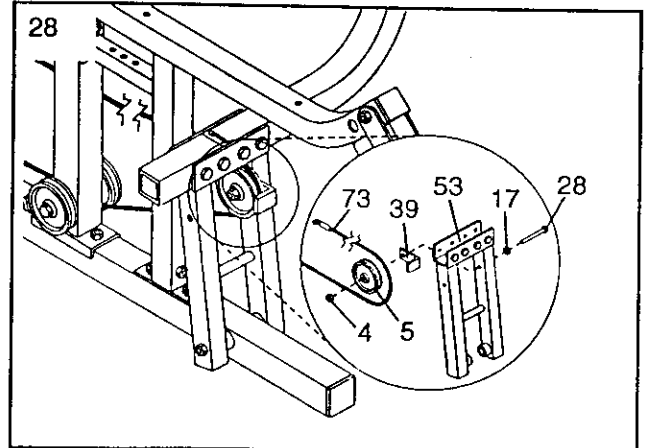

29. Wrap the Long Cable (73) around a "V"-Pulley (21) in the direction shown. Attach the "V"-Pulley and a Large Cable Trap (14) to the small tube on the Press Seat Frame (52) with a 3/8" x 3 1/4" Bolt (28), a 3/8" Flat Washer (17) and a 3/8" Nylon Locknut (4). **Note: The small tube has three adjustment holes. Mount the "V"-Pulley in the hole farthest from the Upright. Make sure the Cable Trap is oriented as shown.**

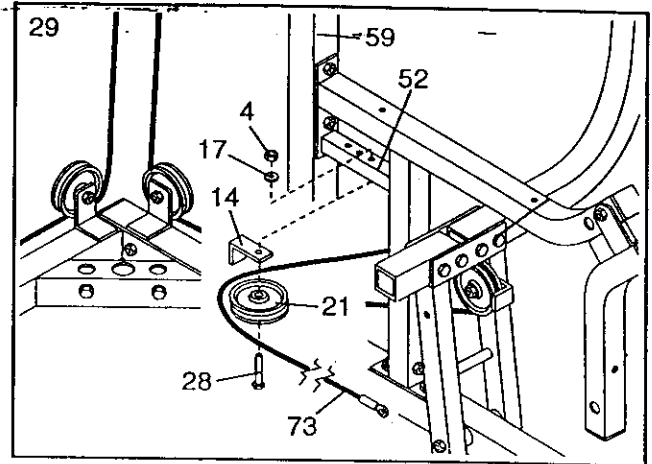

30. Route the Long Cable (73) back through the opening in the Press Frame (53) and wrap the Long Cable around a 3 1/2" Pulley (5) in the direction shown. Then, route the Long Cable back through the opening in the Press Frame.

Attach the 3 1/2" Pulley (5) and a Cable Trap (39) to the indicated hole in the Press Frame (53) with a 3/8" x 3 1/4" Bolt (28), 3/8" Flat Washer (17), and a 3/8" Nylon Locknut (4). **Make sure the Pulley is mounted on the inside of the Press Frame. Make sure the Cable Trap is oriented as shown.**

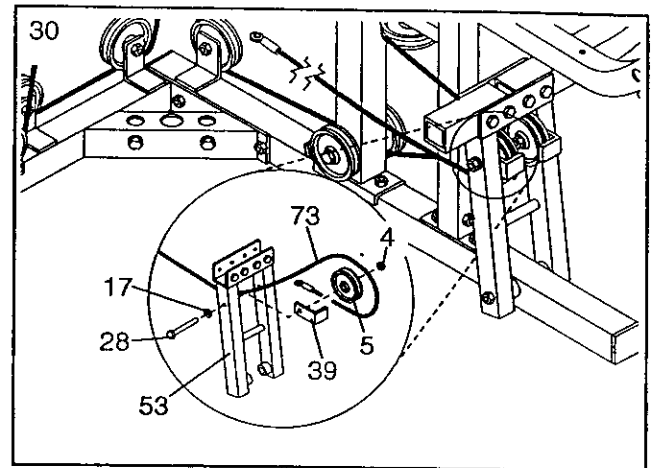

31. Route the Long Cable (73) around a 3 1/2" Pulley (5) and back through the opening in the Press Frame (53).

Remove the 3/8" Nylon Locknut (4) from the 3/8" x 4 3/4" Bolt (23) that was inserted in step 27. Attach the Pulley and a Cable Trap (39) to the Bolt and secure the Pulley with the 3/8" Nylon Locknut (4). **Make sure the Cable Trap is oriented as shown.**

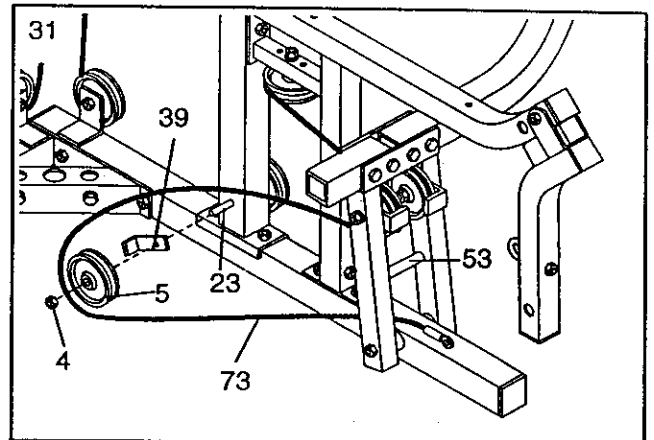

32. **Note: Lift the top weight on the weight stack in order to create slack in the Long Cable before beginning this step.**

Attach the Long Cable (73) to the Leg Lever (49), slipping the looped end of the Cable through the looped end of the Eye Bolt (83).

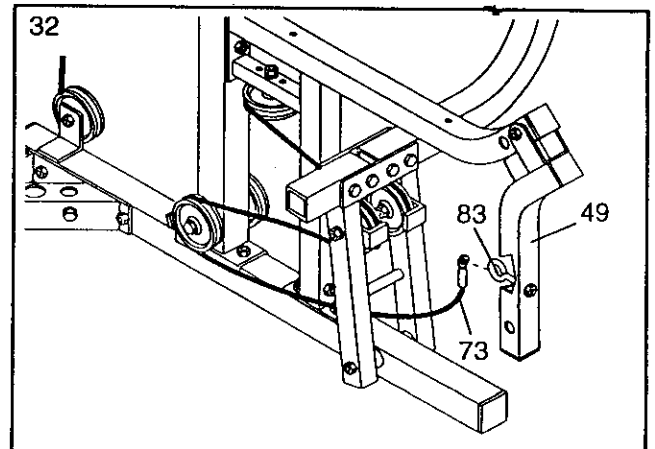

Seat Assembly

33. Locate and open the parts bag labeled "SEAT ASSEMBLY."

Insert a 1/4" x 2" Carriage Bolt (85) through the center hole in a Seat Plate (42). Attach the Seat Plate to a Seat (51) with two 1/4" x 3/4" Screws (13).

Insert the 1/4" x 2" Carriage Bolt (85) into the indicated hole in the Press Seat Frame (52) and secure it with a 1/4" Flat Washer (11) and a 1/4" Nylon Locknut (16). Secure the other end of the Seat (51) with a 1/4" x 2" Bolt (86) and a 1/4" Flat Washer (11).

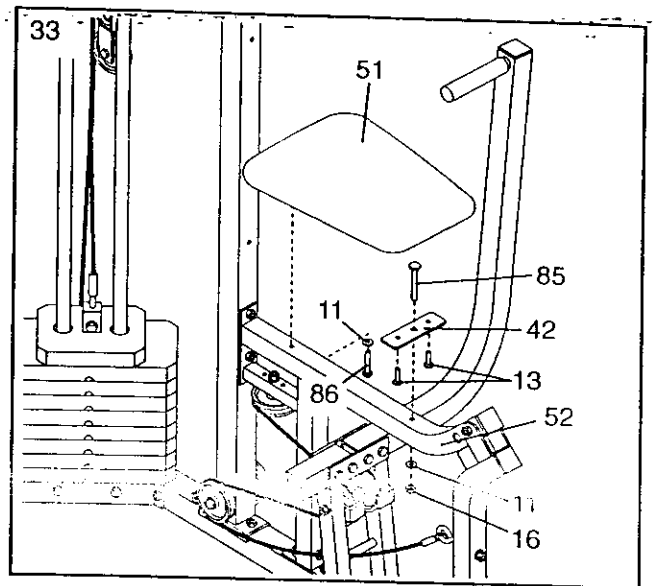

34. Press four 3/4" Round Inner Caps (40) into the ends of the Pad Tubes (48) and the indicated tubes on the Leg Lever (49) and the Press Seat Frame (52).

Insert the Pad Tubes (48) into the indicated holes in the Leg Lever (49) and the Press Seat Frame (52). Slide Foam Pads (47) onto the ends of the Pad Tubes.

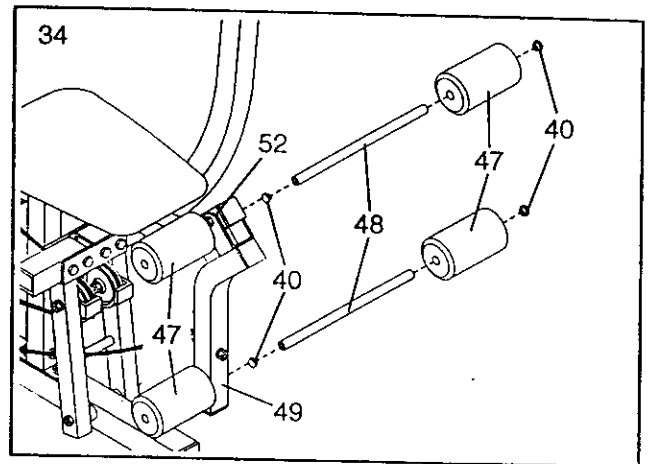

35. Insert a 1/4" x 2 1/2" Carriage Bolt (12) through the center hole in a Seat Plate (42). Attach the Seat Plate to the Press Backrest (89) with two 1/4" x 3/4" Screws (13).

Insert the 1/4" x 2 1/2" Carriage Bolt (12) with a 1/4" Flat Washer (11) into the indicated hole in the Press Frame Upright (59) and secure it with a 1/4" Nylon Locknut (16).

Secure the other end of the Press Backrest (89) with a 1/4" x 2 1/2" Screw (10) and a 1/4" Flat Washer (11).

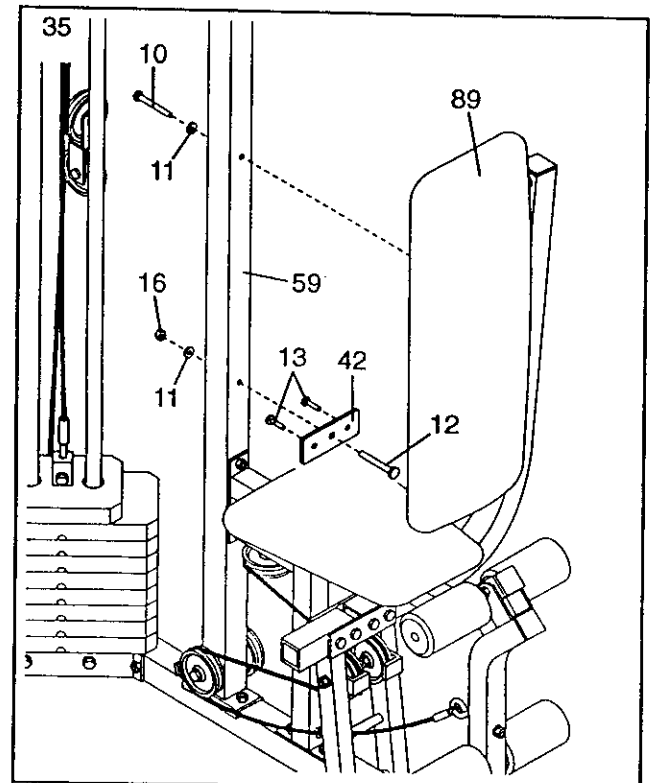

36. Insert a 1/4" x 1 1/2" Carriage Bolt (82) through the center hole in a Seat Plate (42). Attach the Seat Plate to a Seat (51) with two 1/4" x 3/4" Screws (13).

Insert the 1/4" x 1 1/2" Carriage Bolt (82) into the indicated hole in the Seat Bar (74) and secure it with a 1/4" Flat Washer (11) and a 1/4" Nylon Locknut (16). Secure the other end of the Seat (51) with a 1/4" x 1 1/2" Screw (88) and a 1/4" Flat Washer (11).

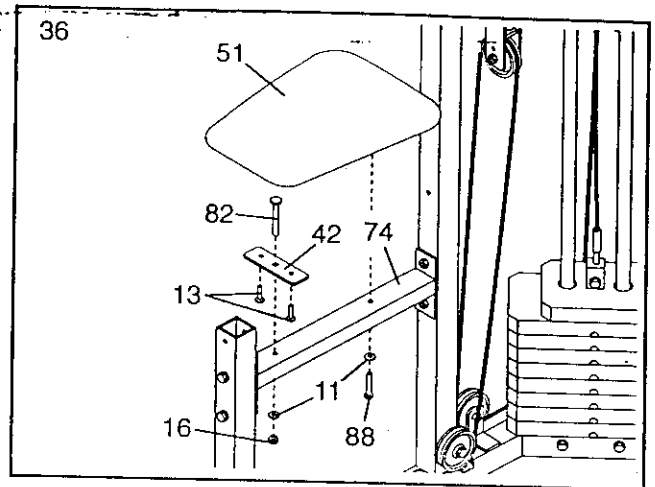

37. Attach the Backrest (66) to the indicated holes in the Butterfly Upright (62) with two 1/4" x 2 1/2" Screws (10) and two 1/4" Flat Washers (11).

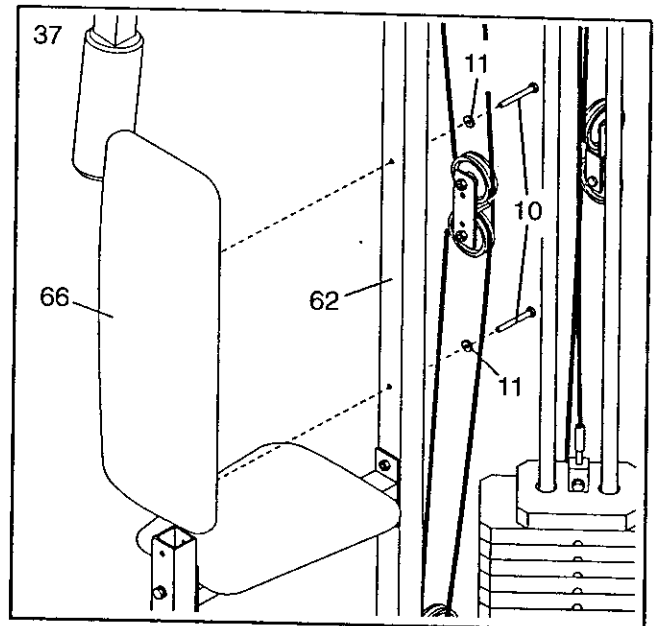

Miscellaneous Assembly

38. Attach the Curl Pad (69) to the Curl Post (70) with two 1/4" x 3/4" Screws (13).

Insert the Curl Post (70) into the Seat Brace (75) and secure the Curl Post at the desired height with the Adjustment Knob (45).

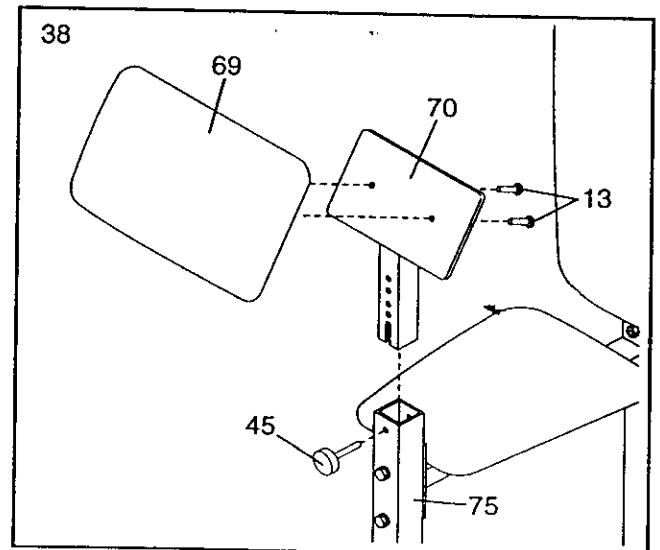

39. Apply the WEIDER PRO 9930 decal in the location shown.

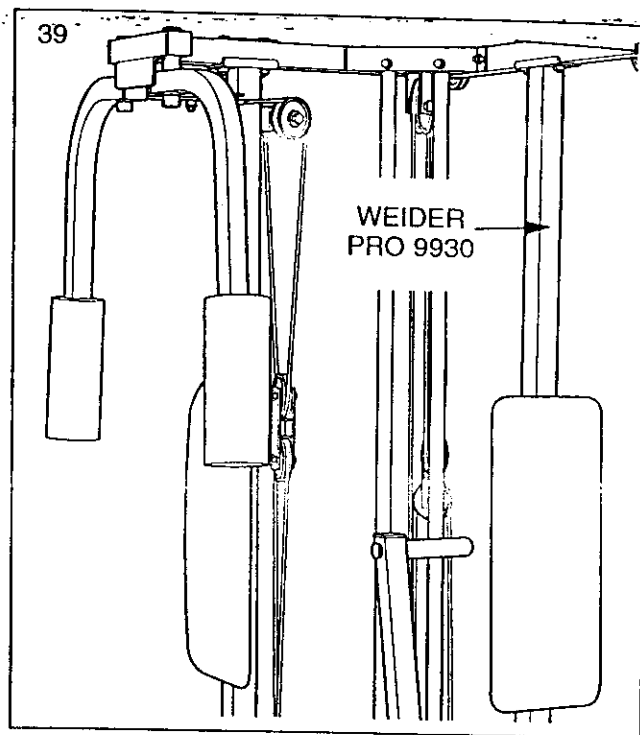

40. Make sure that all parts have been properly tightened. The use of the remaining parts will be explained in ADJUSTMENT, beginning on page 21 of this manual.

Before using the home gym, pull each cable a few times to make sure that the cables move smoothly over the pulleys. If one of the cables does not move smoothly, find and correct the problem. **IMPORTANT: If the cables are not properly installed, they may be damaged when heavy weight is used. If there is any slack in the cables, you will need to remove the slack by tightening the cables. See TROUBLESHOOTING AND MAINTENANCE on page 22.**

Cable Diagrams

The Cable Diagrams below and on the next page show the proper routing of the Short Cable (71), the Medium Cable (72), and the Long Cable (73). The numbers show the correct route for each Cable. Make sure that the Cables are routed correctly, that the Pulleys move smoothly, and that the Cable Traps do not touch or bind the Cables. Incorrect cable routing can damage the home gym.

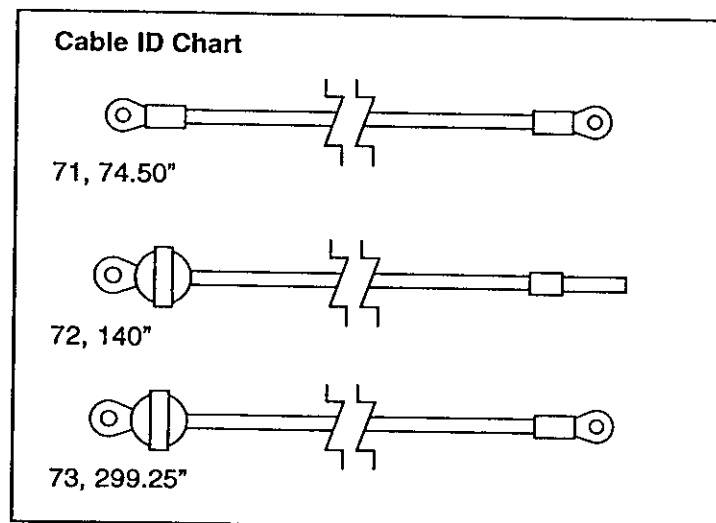
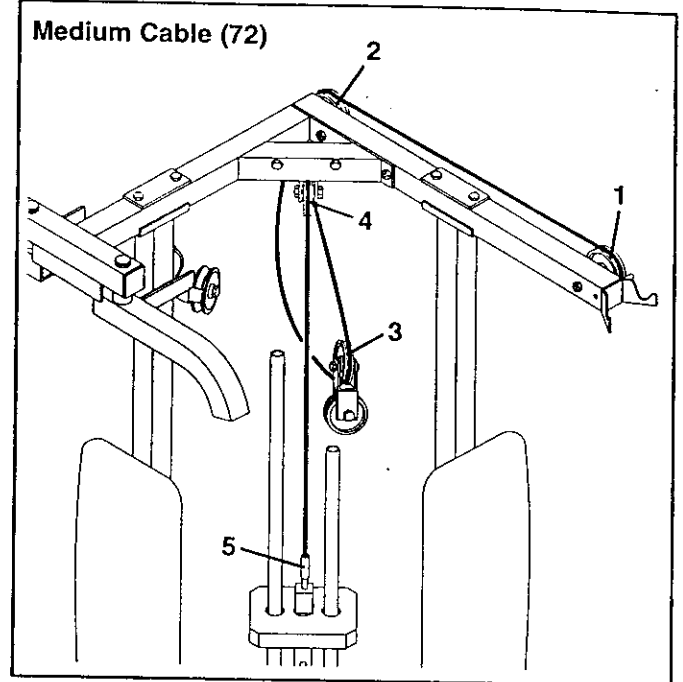
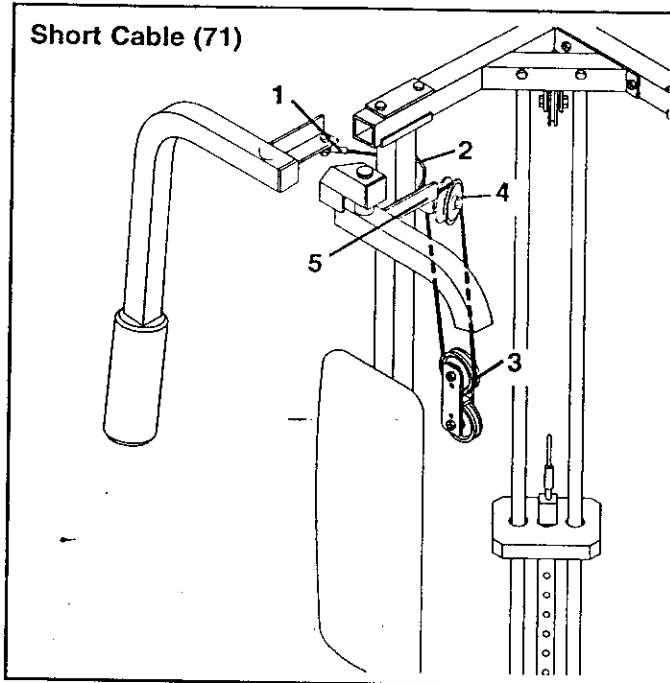

Long Cable (73)

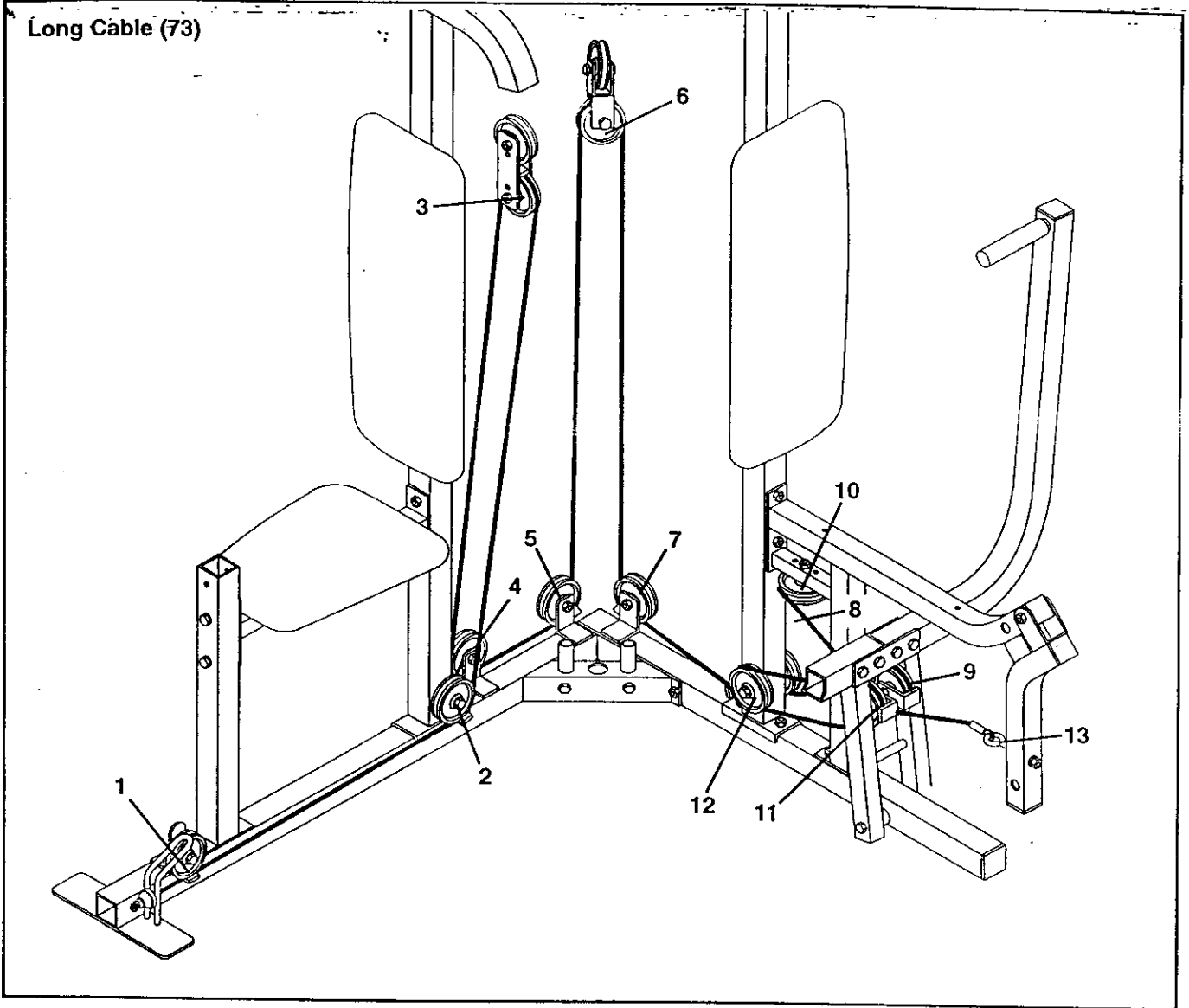

Adjustment

The instructions below describe how each part of the home gym can be adjusted. Refer to the exercise poster accompanying this manual to see how the home gym should be set up for each exercise. **IMPORTANT: When using an attachment, make sure it is in the correct starting position for the exercise to be performed. If there is any slack in the cables or chain as an exercise is performed, the effectiveness of the exercise will be reduced.**

Changing the Weight Setting

To change the setting of the weight stack, insert a Weight Pin (87) under the desired Weight (8). Make sure you insert the Weight Pin as far as it will go. **Note: Due to the cables and pulleys, the amount of resistance at each exercise station may vary from the weight setting. Use the WEIGHT RESISTANCE CHART on page 23 to find the approximate amount of resistance at each weight station.**

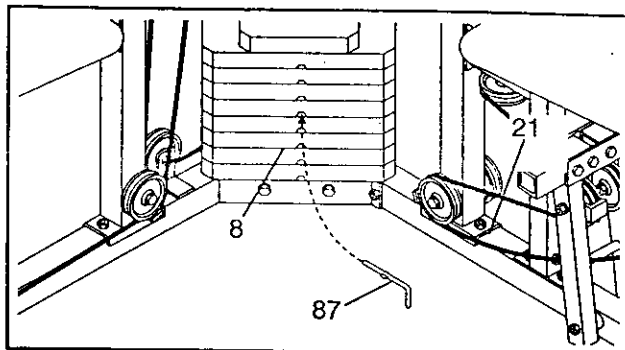

Attaching the Lat Bar or Nylon Strap to the High Pulley Station

Attach the Lat Bar (50) to the Medium Cable (72) with a Cable Clip (57). For some exercises, the Chain (55) should be attached between the Lat Bar and the Medium Cable with two Cable Clips. **Adjust the length of the Chain between the Lat Bar and the Medium Cable so the Lat Bar is in the correct starting position for the exercise to be performed.**

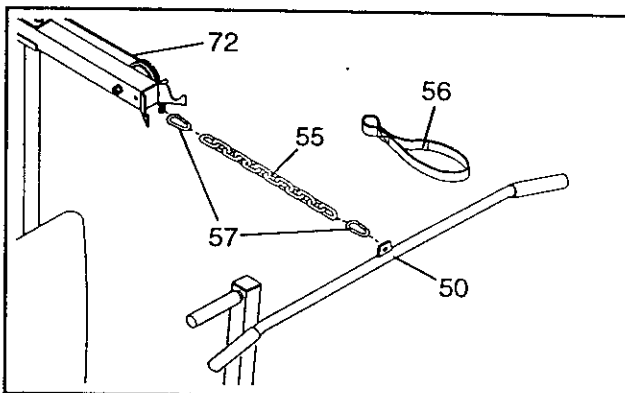

The Nylon Strap (56) can be attached in the same manner.

Attaching the Lat Bar or Nylon Strap to the Low Pulley Station

Attach the Lat Bar (50) to the Long Cable (73) with a Cable Clip (57). For some exercises, the Chain (55) should be attached between the Lat Bar and the Long Cable with two Cable Clips. **Adjust the length of the Chain between the Lat Bar and the Long Pulley Cable so the Lat Bar is in the correct starting position for the exercise to be performed.**

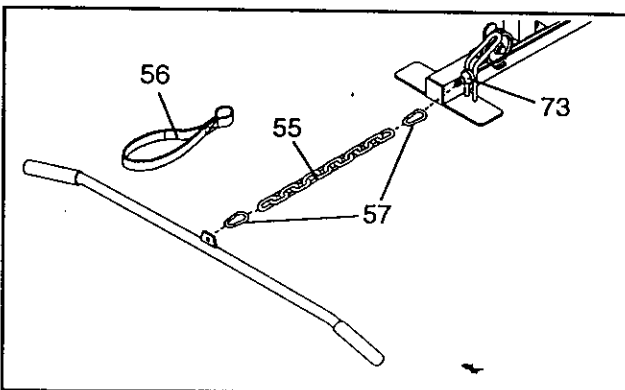

The Nylon Strap (56) can be attached in the same manner.

Using the Curl Pad

To use the Curl Pad (69), insert the Curl Post (70) into the Seat Brace (75) and secure the Curl Post at the desired height with the Adjustment Knob (45).

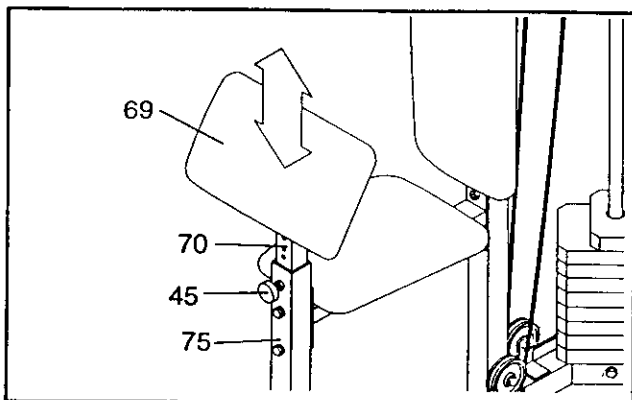

Trouble-shooting and Maintenance

Inspect and tighten all parts each time you use the home gym. Replace any worn parts immediately. The home gym can be cleaned using a damp cloth and mild non-abrasive detergent. Do not use solvents.

Tightening the Cables

If a cable slips off the pulleys often, the cable may have become twisted. Remove the cable and re-install it. If the cables need to be replaced, see ORDERING REPLACEMENT PARTS on the back cover of this manual.

The type of cable used on the home gym can stretch slightly when it is first used. If there is slack in the cables before resistance is felt, the cables should be tightened. Slack can be removed from the cables in several different ways:

The Adjustable Pulley Plates (44) have two sets of adjustment holes. By moving one or both 3 1/2" Pulleys (5) to a different set of holes, you will tighten the cables.

To move a 3 1/2" Pulley (5), remove the 3/8" Nylon Locknut (4) and the 3/8"x 2" Bolt (35). Remove the Cable Trap (39) and Pulley from the Adjustable Pulley Plates (44). Re-attach the Pulley and Cable Trap to the appropriate adjustment hole in the Pulley Plates. **Note: Begin by moving one Pulley to the second adjustment hole.** If additional adjustment is needed, move the other Pulley until the cables are tight.

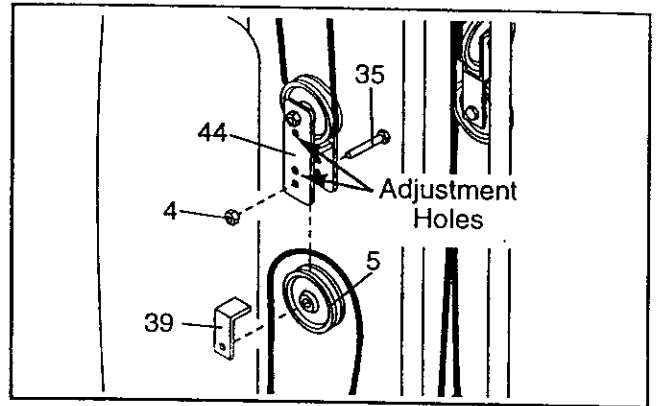

Slack can be removed from the Long Cable (73) by moving the 3 1/2" Pulley (5) on the Long Cable in the direction shown. It is attached to the small tube on the Press Seat Frame (52). There are two free holes in the small tube, and you can move the 3 1/2" Pulley to any one of them to tighten the cables. To do this, remove the 3/8" Nylon Locknut (4), 3/8" Flat Washer (17), and the 3/8" x 2 1/2" Bolt (6). Start by moving the 3 1/2" Pulley one hole, and then one more as needed.

Reattach the Bolt, Washer, and Locknut.

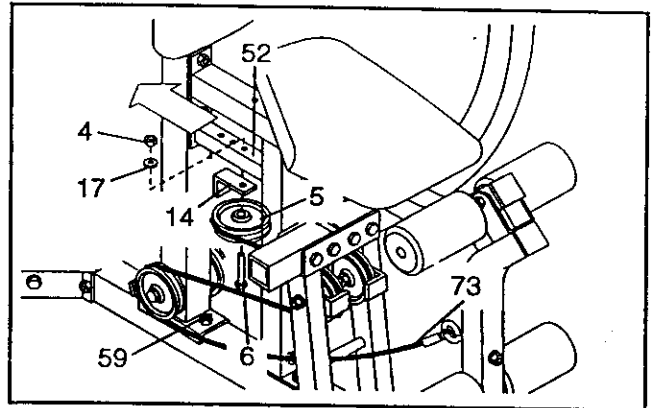

The threaded shaft on the Medium Cable (72) attached to the Weights (8) can also be used to tighten the cables.

To tighten the Medium Cable (72), remove the Small "U"-Bracket (43) by removing the 5/16" Nylon Locknut (2) and the 5/16" x 1 3/4" Bolt (9).

See the inset drawing. Tighten the 1/4" Nylon Locknut (16) at the end of the Medium Cable (72) as far as it will go. Then re-attach the Small "U"-Bracket (43).

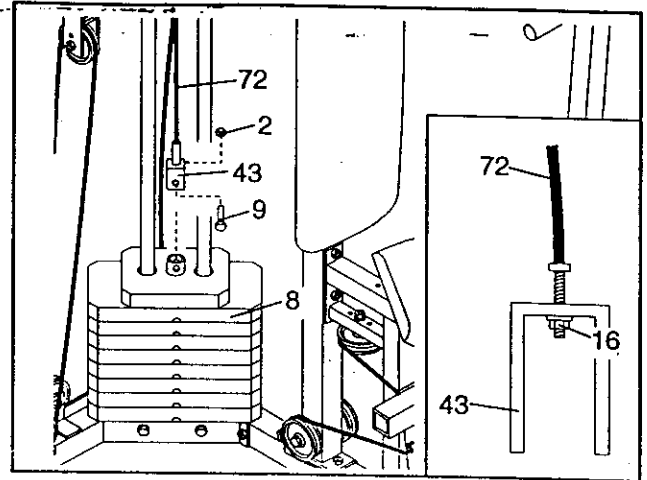

Weight Resistance Chart

The chart below shows the approximate weight resistance at each exercise station. "Top" refers to the 6 lb. top weight; the other numbers refer to the 12.5 lb. weight plates. **Note: The actual resistance at each station may vary due to differences in individual weight plates as well as friction between the cables, pulleys, and weight guides.**

Weight Plates	High Pulley (lbs.)	Arm Press (lbs.)	Butterfly (lbs.)	Curl/ Low Pulley (lbs.)	Leg Raise (lbs.)
Top	11	20	15	16	17
1	25	39	31	32	37
2	40	59	48	47	56
3	55	78	64	63	76
4	70	97	80	78	95
5	84	117	97	93	115
6	99	136	113	109	135
7	114	156	130	124	154
8	128	175	146	140	174

**REMOVE THIS PART LIST/EXPLODED
DRAWING FROM THE MANUAL**

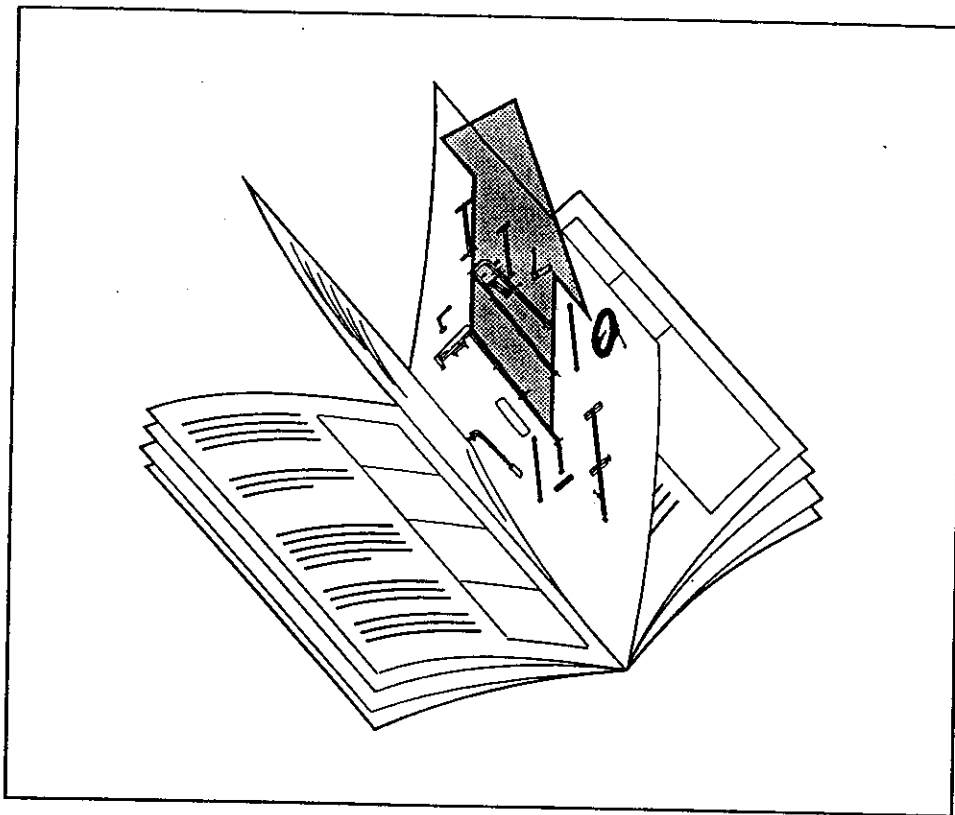

Part List—Model No. 831.159720

R0999A

Key No.	Qty.	Description	Key No.	Qty.	Description
1	8	5/16" x 2 1/2" Carriage Bolt	49	1	Leg Lever
2	27	5/16" Nylon Locknut	50	1	Lat Bar
3	12	5/16" x 2 1/2" Bolt	51	2	Seat
4	17	3/8" Nylon Locknut	52	1	Press Seat Frame
5	15	3 1/2" Pulley	53	1	Press Frame
6	6	3/8" x 2 1/2" Bolt	54	2	Press Arm
7	2	3/8" x 3 3/4" Bolt	55	1	Chain
8	8	Weight	56	1	Nylon Strap
9	1	5/16" x 1 3/4" Bolt	57	4	Cable Clip
10	3	1/4" x 2 1/2" Screw	58	2	Weight Guide
11	9	1/4" Flat Washer	59	1	Press Frame Upright
12	1	1/4" x 2 1/2" Carriage Bolt	60	1	Press Base
13	8	1/4" x 3/4" Screw	61	1	Butterfly Base
14	3	Long Cable Trap	62	1	Butterfly Upright
15	2	3/8" x 1" Bolt	63	1	Press Top Frame
16	4	1/4" Nylon Locknut	64	1	Butterfly Top Frame
17	14	3/8" Flat Washer	65	2	10" Pad
18	9	3/8" Jam Nut	66	1	Backrest
19	10	5/16" Flat Washer	67	1	Left Butterfly Arm
20	6	5/16" x 2 3/4" Bolt	68	1	Right Butterfly Arm
21	3	"V" Pulley	69	1	Curl Pad
22	3	3/8" x 1 3/4" Bolt	70	1	Curl Post
23	1	3/8" x 4 3/4" Bolt	71	1	Short Cable
24	1	3/8" x 3 1/2" Bolt	72	1	Medium Cable
25	4	1" Retainer	73	1	Long Cable
26	2	1" Round Cap	74	1	Seat Bar
27	2	1 1/8" x 2 1/2" Plastic Bushing	75	1	Seat Brace
28	3	3/8" x 3 1/4" Bolt	76	1	Weight Tube Bumper
29	2	1" x 7/8" Plastic Bushing	77	1	Weight Tube
30	1	3/8" x 8" Bolt	78	1	Top Weight
31	4	Hand Grip	79	3	1 1/2" Square Inner Cap
32	1	#10 x 1" Screw	80	2	1" Inner Cap
33	1	Bumper	81	1	5/16" x 2 1/4" Bolt
34	1	4 1/2" Pulley	82	1	1/4" x 1 1/2" Carriage Bolt
35	6	3/8" x 2" Bolt	83	1	3/8" x 2 1/2" Eye Bolt
36	1	Double "U" Bracket	84	2	Weight Bumper
37	6	1 3/4" Square Inner Cap	85	1	1/4" x 2" Carriage Bolt
38	6	2" Square Inner Cap	86	1	1/4" x 2" Bolt
39	12	Cable Trap	87	1	Weight Pin
40	4	3/4" Round Inner Cap	88	1	1/4" x 1 1/2" Screw
41	2	1" Round Inner Cap	89	1	Press Backrest
42	3	Seat Plate	90	1	5/16" Jam Nut
43	1	Small "U" Bracket	#	1	User's Manual
44	2	Adjustable Pulley Plate	#	1	Exercise Poster
45	1	Adjustment Knob			
46	2	Top Plate			
47	4	Foam Pad			
48	2	Pad Tube			

Note: "#" indicates a non-illustrated part. Specifications are subject to change without notice.

Note: "#" indicates a non-illustrated part. Specifications are subject to change without notice.

Exploded Drawing—Model No. 831.159720

R0999A

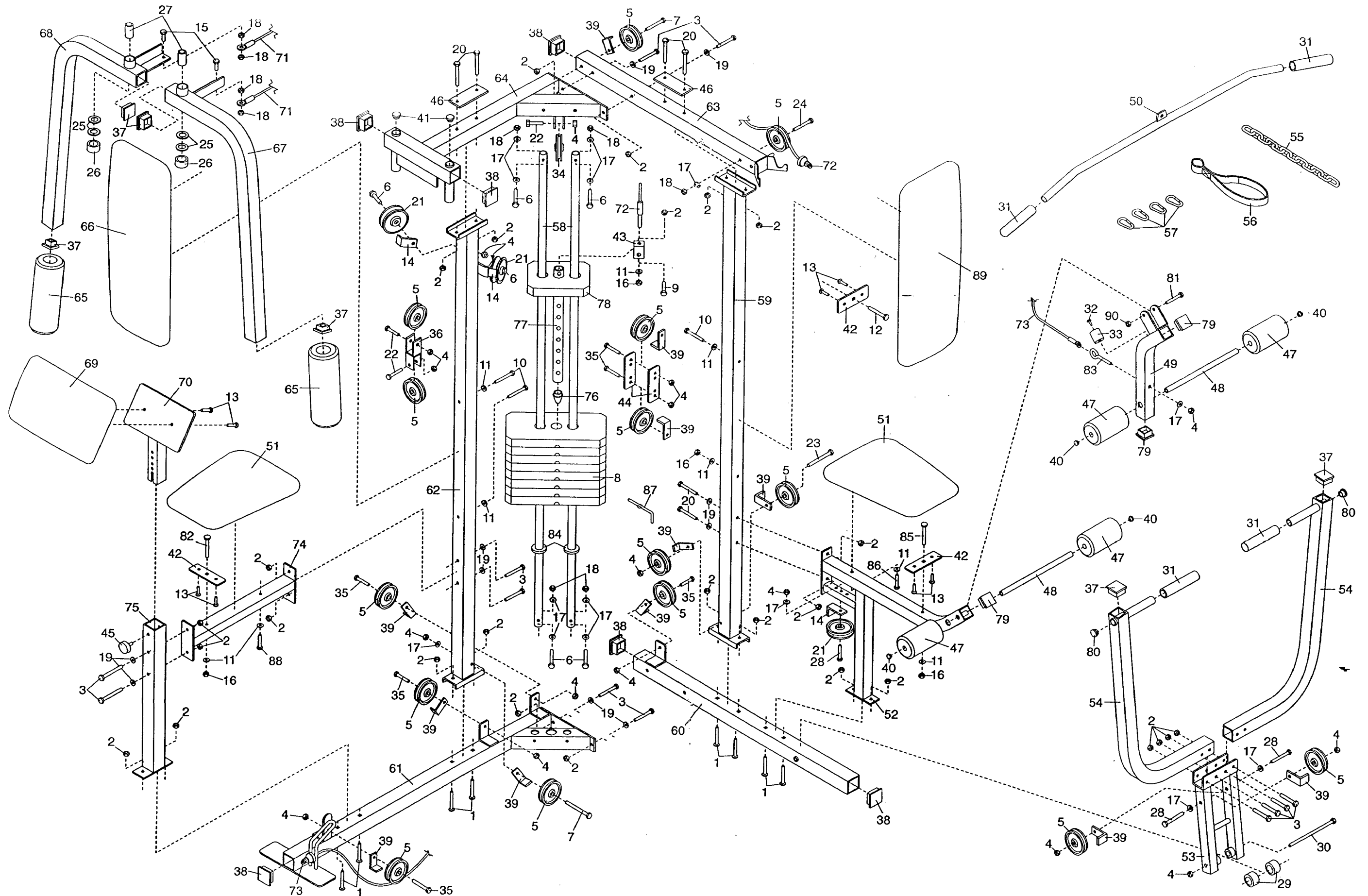

REMOVE THIS PART IDENTIFICATION CHART FROM THE MANUAL

This chart is provided to help you identify the small parts used in assembly. The number in parenthesis below each part refers to the key number of the part. **Important: Some parts may have been pre-assembled for shipping purposes. If you cannot find a part in the parts bags, check to see if it has been pre-assembled.**

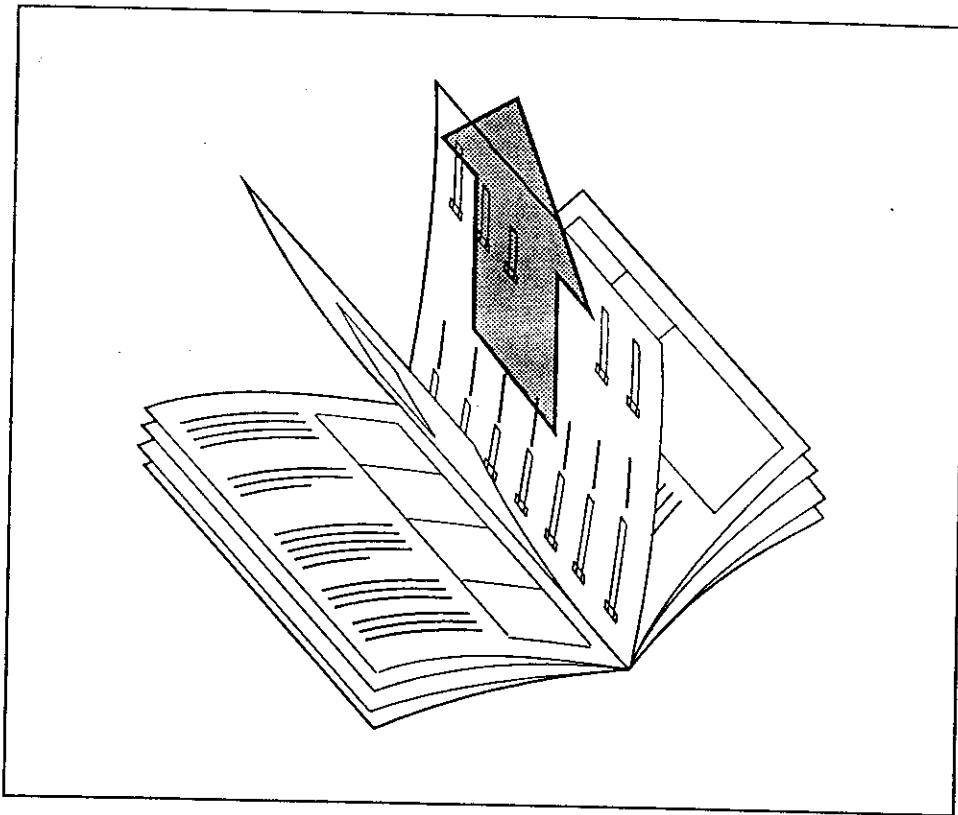

Note: Assembly is divided into four stages: 1) frame assembly; 2) arm assembly; 3) cable and pulley assembly; and 4) seat assembly. The hardware for each assembly stage is packaged separately. Wait until you begin each stage to open that parts bag.

Part Identification Chart—Model No. 831.159720

R0999A

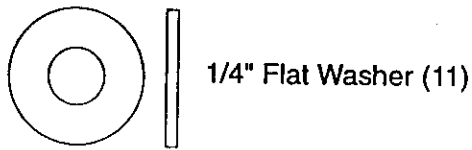

1/4" Flat Washer (11)

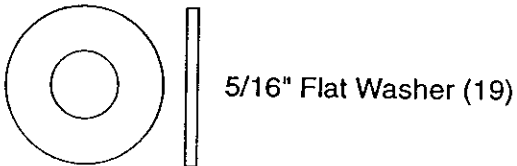

5/16" Flat Washer (19)

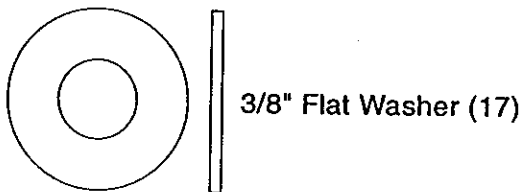

3/8" Flat Washer (17)

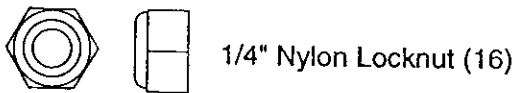

1/4" Nylon Locknut (16)

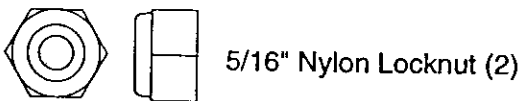

5/16" Nylon Locknut (2)

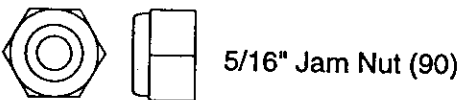

5/16" Jam Nut (90)

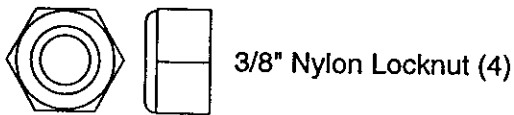

3/8" Nylon Locknut (4)

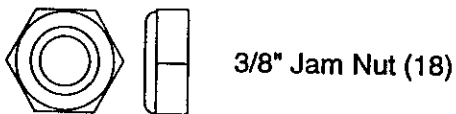

3/8" Jam Nut (18)

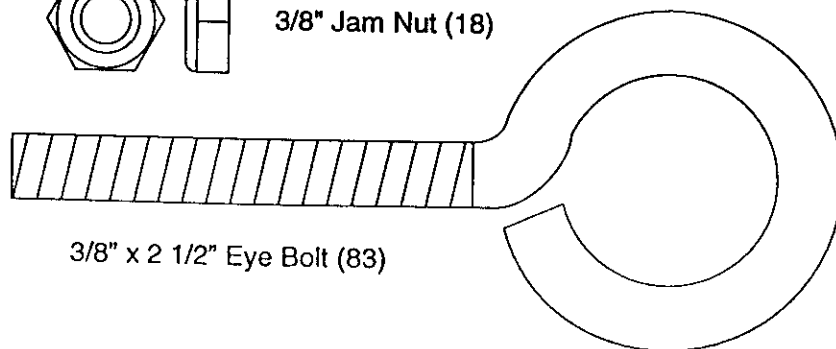

3/8" x 2 1/2" Eye Bolt (83)

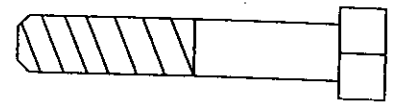

5/16" x 1 3/4" Bolt (9)

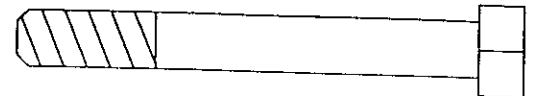

5/16" x 2 1/2" Bolt (3)



5/16" x 2 3/4" Bolt (20)

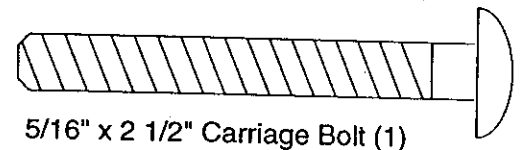

5/16" x 2 1/2" Carriage Bolt (1)

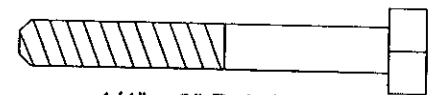

1/4" x 2" Bolt (86)

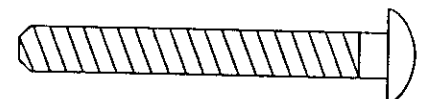

1/4" x 2" Carriage Bolt (85)

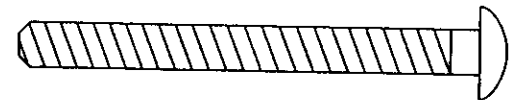

1/4" x 2 1/2" Carriage Bolt (12)

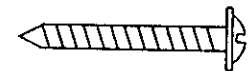

#10 x 1" Screw (32)



1/4" x 3/4" Screw (13)

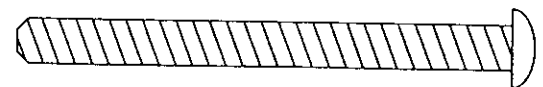

1/4" x 2 1/2" Screw (10)

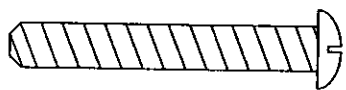

1/4" x 1 1/2" Screw (88)

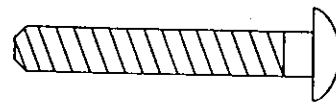

1/4" x 1 1/2" Carriage Bolt (82)

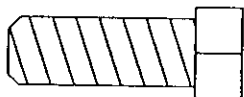

3/8" x 1" Bolt (15)



"V" Pulley (21)
(Not shown to scale)

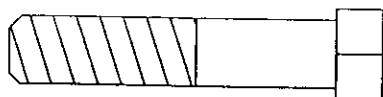

3/8" x 1 3/4" Bolt (22)



3 1/2" Pulley (5)
(Not shown to scale)

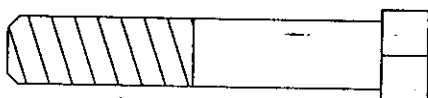

3/8" x 2" Bolt (35)

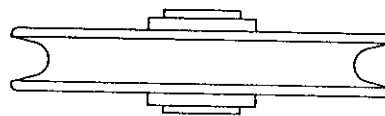

4 1/2" Pulley (34)
(Not shown to scale)

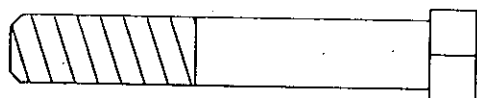

3/8" x 2 1/4" Bolt (81)

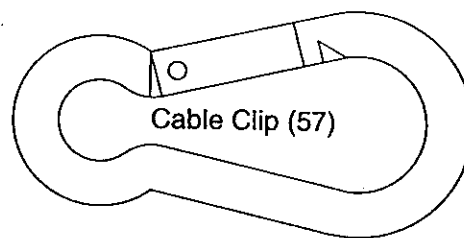

Cable Clip (57)

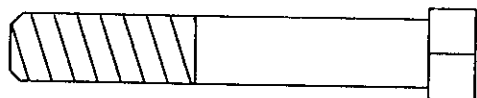

3/8" x 2 1/2" Bolt (6)

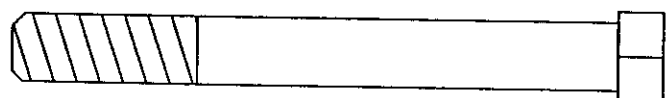

3/8" x 3 1/4" Bolt (28)

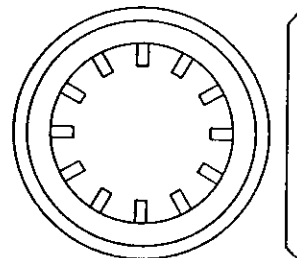

1" Retainer (25)

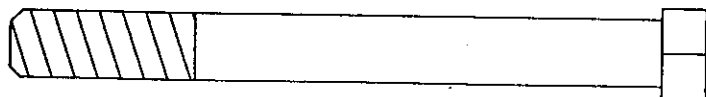

3/8" x 3 1/2" Bolt (24)

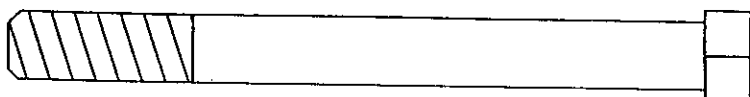

3/8" x 3 3/4" Bolt (7)

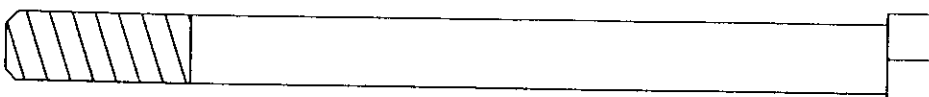

3/8" x 4 3/4" Bolt (23)

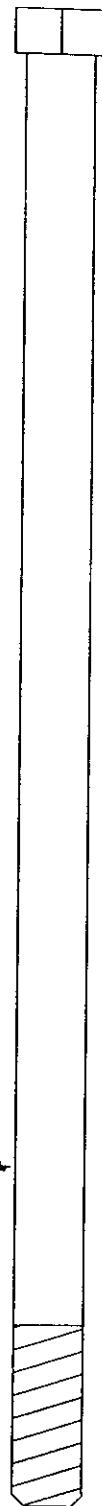

3/8" x 8" Bolt (30)

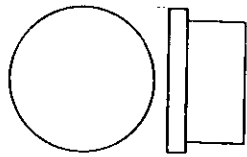

3/4" Round Inner Cap (40)

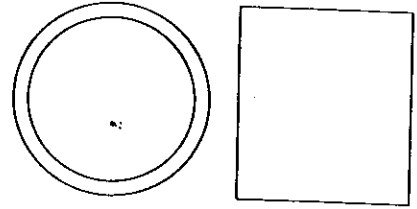

1" x 7/8" Plastic Bushing (29)

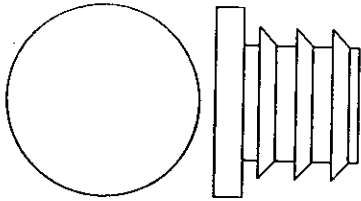

1" Round Inner Cap (41)

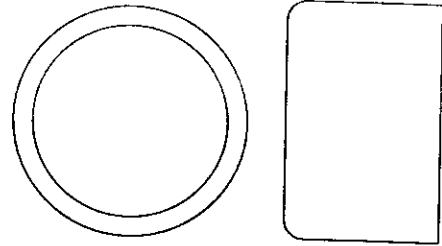

1" Round Cap (26)

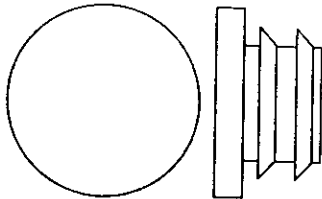

1" Inner Cap (80)

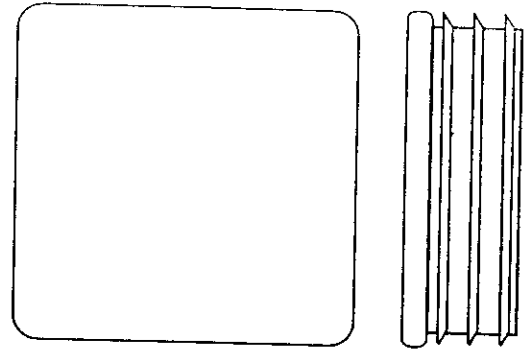

1 3/4" Square Inner Cap (37)

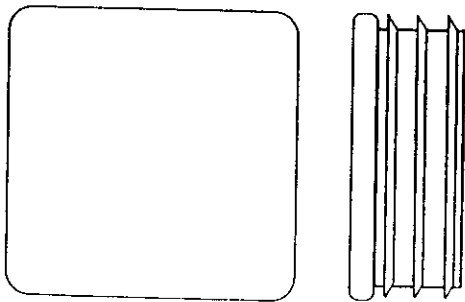

1 1/2" Square Inner Cap (79)

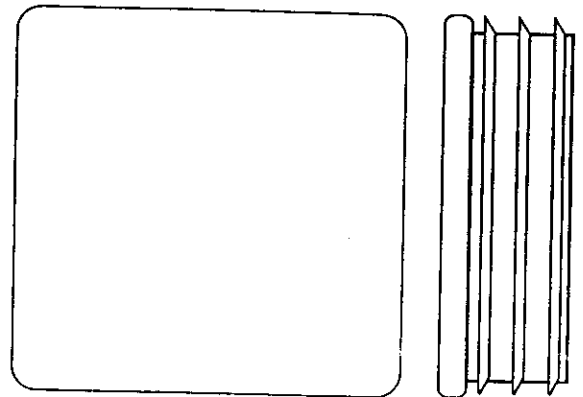

2" Square Inner Cap (38)

SEARS

Model No. 831.159720

QUESTIONS?

If you find that:

- you need help assembling or operating the WEIDER® PRO 9930 Home Gym
- a part is missing
- or you need to schedule repair service

call our toll-free HELPLINE

1-800-736-6879

Monday-Saturday, 7 am-7 pm
Central Time (excluding holidays)

ORDERING REPLACE- MENT PARTS

If parts become worn and need to be replaced, call the following toll-free number

1-800-FON-PART

(1-800-366-7278)

The model number and serial number of your WEIDER® PRO 9930 Home Gym are listed on a decal attached to the frame. See the front cover of this manual to find the location of the decal.

All replacement parts are available for immediate purchase or special order when you visit your nearest SEARS Service Center. To request service or to order parts by telephone, call the toll-free numbers listed at the left.

When requesting help or service, or ordering parts, please be prepared to provide the following information:

- The MODEL NUMBER of the product (831.159720)
- The NAME of the product (WEIDER® PRO 9930 Home Gym)
- The KEY NUMBER and DESCRIPTION of the PART (see the PART LIST/EXPLODED DRAWING in the center of this manual).

SEARS, ROEBUCK AND CO., HOFFMAN ESTATES, IL 60179

FULL 90 DAY WARRANTY

For 90 days from the date of purchase, if failure occurs due to defect in material or workmanship in this SEARS WEIGHT SYSTEM EXERCISER, contact the nearest SEARS Service Center throughout the United States and SEARS will repair or replace the WEIGHT SYSTEM EXERCISER, free of charge.

This warranty does not apply when the WEIGHT SYSTEM EXERCISER is used commercially or for rental purposes.

This warranty gives you specific legal rights, and you may also have other rights which vary from state to state.

SEARS, ROEBUCK AND CO., DEPT. 817WA, HOFFMAN ESTATES, IL 60179