

AP-6511 SERIES ACCESS POINT INSTALLATION GUIDE

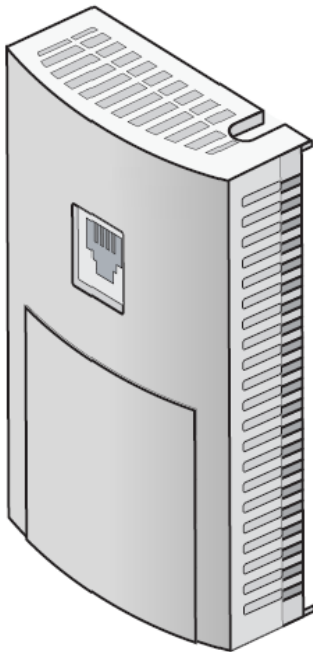

Zebra and the Zebra head graphic are registered trademarks of ZIH Corp. The Symbol logo is a registered trademark of Symbol Technologies, Inc., a Zebra Technologies company.

© 2015 Symbol Technologies, Inc.

1.0 Introduction	5
1.1 Document Conventions	5
1.2 Warnings	6
1.3 Site Preparation	6
1.4 Package Contents	6
1.5 Features	6
2.0 Hardware Installation	8
2.1 Installation Instructions	8
2.2 Precautions	9
2.3 Access Point Placement	9
2.4 Power Injector System	9
2.5 Wall Mount Installation	10
2.6 Telco Box Installation	13
2.7 Antennas	17
2.8 LED Indicators	17
3.0 Basic Access Point Configuration	18
4.0 Specifications	29
4.1 Electrical Characteristics	29
4.2 Physical Characteristics	29
4.3 Radio Characteristics	30
5.0 Regulatory Information	31
5.1 Regulatory Overview	31
5.2 Wireless Device Country Approvals	31
5.2.1 Country Selection - Note for AP & Wireless Controller	31
5.2.2 Frequency of Operation - FCC and IC	32
5.3 Health and Safety Recommendations	32
5.3.1 Warnings for the use of Wireless Devices	32
5.3.2 Potentially Hazardous Atmospheres - Fixed Installation	32
5.3.3 Safety in Hospitals	32

5.4 RF Exposure Guidelines	33
5.4.1 Safety Information	33
5.5 International	33
5.6 EU	33
5.7 US and Canada	33
5.8 Power Supply	34
5.9 Radio Frequency Interference Requirements - FCC	34
5.10 Radio Frequency Requirements - Canada	34
5.10.1 Radio Transmitters	34
5.11 CE Marking and European Economic Area (EEA)	35
5.12 Mexico	35
5.13 Statement of Compliance	35
5.14 Waste Electrical and Electronic Equipment (WEEE)	36
5.15 Turkish WEEE Statement of Compliance	37
5.16 Japan (VCCI) - Voluntary Control Council for Interference Class B ITE	38
5.17 Korea Warning Statement for Class B ITE	38
5.17 Other Countries	38
6.0 Support	41
6.1 Customer Support Web Sites	41
6.2 Manuals	41
6.3 General Information	41
7.0 AP-6511 Series Access Point China ROHS Agreement	42

1 Introduction

An AP-6511 Series Access Point is an enterprise class 802.11n Access Point, installed in minutes anywhere a CAT-5 (or better) cable is located. The Access Point's mechanical design is optimized for installation over a standard CAT-5 (or better) wall jack. The AP does not protrude into the wall cavity, allowing for an efficient heat transfer and a universal installation over a standard Telco wiring plate. The Access Point's modular design allows the end-user to add switched Ethernet ports as-needed, and attach a standard keystone or Leviton QuickPort® modular connector to the wall plate.

The Access Point ships with a single dual-band radio supporting the 802.11a/b/g/n radio bands.

The Access Point receives all power and transfers data through the same CAT-5 or better Ethernet cable. There is no additional power supply required. An 802.3af PoE Ethernet switch or mid span power injector is required.

The Access Point can be ordered for US deployment (AP-6511-60010-US or AP-6511E-60010-US), deployment in Europe (AP-6511-60010-EU or AP-6511E-60010-EU) or deployment outside of the US or Europe (AP-6511-60010-WR or AP-6511E-60010-WR).

1.1 Document Conventions

The following graphical alerts are used in this document to indicate notable situations:



NOTE Tips, hints, or special requirements that you should take note of.



CAUTION Care is required. Disregarding a caution can result in data loss or equipment malfunction.



WARNING! Indicates a condition or procedure that could result in personal injury or equipment damage.

1.2 Warnings

- Read all installation instructions and site survey reports, and verify correct equipment installation before connecting the Access Point.
- Remove jewelry and watches before installing this equipment.
- Verify the unit is grounded before connecting it to the power source.
- Verify any device connected to this unit is properly wired and grounded.
- Verify there is adequate ventilation around the device, and that ambient temperatures meet equipment operation specifications.

1.3 Site Preparation

- Consult your site survey and network analysis reports to determine specific equipment placement, power drops, and so on.
- Assign installation responsibility to the appropriate personnel.
- Identify and document where all installed components are located.
- Ensure adequate, dust-free ventilation to all installed equipment.
- Prepare Ethernet port connections.
- Verify cabling is within the maximum 100 meter allowable length.

1.4 Package Contents

The Access Point is available in integrated antenna and external antenna models. Contents differ depending on the model ordered.

- Access Point
- Mounting plate (used for both wall mount and Telco Box installations)
- Mounting plate lock screw
- Installation Guide (*This Guide*)
- RJ-45 double plug interconnect cable
- Fast Ethernet port 1 interconnect cable

1.5 Features

- One RJ-45 PoE Ethernet port (built into the Access Point)
- Optional second RJ-45 Ethernet port utilizing a pass through (keystone) cable (included)
- Optional three port Ethernet expansion module (sold separately)
- 2 LED indicators

The pass through (keystone) cable provides an option to add a second Ethernet port before installing the Access Point.

An AP-6511 Series Access Point has one RJ-45 connector supporting an 10/100 Ethernet port and requires 802.3af compliant power from an external source.

An AP-6511 Series Access Point ships with a single dual-band radio supporting the 802.11a/b/g/n radio bands.

The Access Point contains runtime firmware which enables the unit to boot after either a power up or a watchdog reset. The runtime firmware on the Access Point can be updated via the Ethernet interface.

The front of the Access Point has an access cover that can be removed to expose an additional connector. A three port RJ-45 Ethernet expansion module connects to the hidden header and snaps onto the Access Point in place of the access cover.

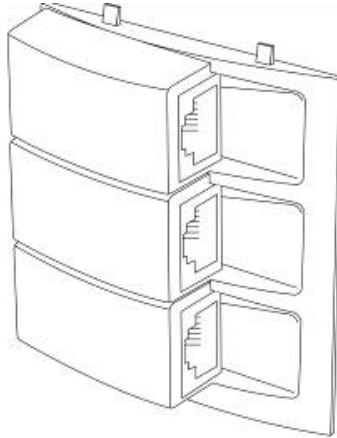

Remove the access cover by inserting a long pointed tool into the circular hole (opening) on the bottom of the Access Point. Pull the access cover up and away from the Access Point. Reverse the procedure to install the expansion module.

The Ethernet expansion module has three ports labeled FE2, FE3 and FE4.

The expansion module (KT-6511-0000D-WR) is a separately orderable component.

2 Hardware Installation

2.1 Installation Instructions

An AP-6511 Series Access Point mounts either on a wall, under a table or over a Telco Box. An AP-6511 Series Access Point is not plenum rated.



NOTE The provided metal mounting plate is fastened to an existing standard Telco in-wall box. The box is customer provided within the customer building structure, and can be either plastic or metal in composition. Screws and other mounting hardware are not include.

An AP-6511 Series Access Point is mounted to a wall or Telco Box so the mounting plate is flush with the mounting surface.

An AP-6511 Series Access Point snaps on to the mounting plate without the use of tools or fastening hardware. Removal of the Access Point from the mounting plate can be accomplished without the use of a tool. A mounting lock screw is provided to help ensure a tamper resistant installation.



NOTE Once installed onto the mounting plate, the assembly can resist a minimum of 10 lbs of force before unit breakage or accidental disassembly.

To prepare for the installation, perform the following:

1. Verify the contents of the box includes the intended Access Point model and accessory hardware.
2. Review site survey and network analysis reports to determine the location and mounting position for the Access Point.
3. Connect a CAT-5 or better Ethernet cable to a PoE compatible device and run the cable to the installation site. Ensure there is sufficient cable slack to perform the installation steps.

2.2 Precautions

Before installing an AP-6511 Series Access Point:

- Verify the intended deployment location is not prone to moisture or dust.
- Verify the environment has a continuous temperature range between 0° C to 40° C.

2.3 Access Point Placement

For optimal performance, install the Access Point away from transformers, heavy-duty motors, fluorescent lights, microwave ovens, refrigerators and other industrial equipment. Signal loss can occur when metal, concrete, walls or floors block transmission. Install the Access Point in an open area or add Access Points as needed to improve coverage.

To maximize the Access Point's radio coverage area, Conduct a site survey to define and document radio interference obstacles before installing the Access Point.

2.4 Power Injector System

When users purchase a WLAN solution, they often need to place Access Points in obscure locations. In the past, a dedicated power source was required for each Access Point in addition to the Ethernet infrastructure. This often required an electrical contractor to install power drops at each Access Point location. The Power Injector merges power and Ethernet into one cable, reducing the burden of installation and allowing optimal Access Point placement in respect to the intended coverage area.

A Power Injector (AP-PSBIAS-2P2-AFR) is recommended as the 802.3af compatible power supply for the AP-6511 Series Access Point. The Power Injector is capable of providing 12.95 Watts up to 100 meters. The Power Injector is separately ordered and not shipped with the AP-6511 Series Access Point. A separate Power Injector is required for each Access Point comprising the network.

The Power Injector has no On/Off power switch. The Injector receives power and is ready for device connection and operation as soon as AC power is applied. Refer to the Installation Guide shipped with the Power Injector for a description of the device's LEDs. The Power Injector can be installed free standing, on an even horizontal surface or wall mounted using the Power Injector's wall mounting key holes.

The following guidelines should be adhered to before cabling the Power Injector to an Ethernet source and an Access Point:

- Do not block or cover airflow to the Power Injector.
- Keep the Power Injector away from excessive heat, humidity, vibration and dust.
- The Power Injector isn't a repeater, and does not amplify the Ethernet signal. For optimal performance, ensure the Power Injector is placed as close as possible to the Ethernet switch. This will allow an AP-6511 Series Access Point to be deployed away from power drops.

- Ensure the cable length from the Ethernet source (host) to the Power Injector and Access Point does not exceed 100 meters (333 ft).



CAUTION To avoid problematic performance and restarts, disable POE from a wired controller port connected to an Access Point if mid-span *power sourcing equipment* (PSE) is used between the two, regardless of the manufacturer.



CAUTION Ensure AC power is supplied to the Power Injector using an AC cable with an appropriate ground connection approved for the country of operation.

2.5 Wall Mount Installation

Ceiling mount requires holding the Access Point up against a T-bar of a suspended ceiling grid and twisting the case onto the T-bar.



NOTE Use the following customer supplied mounting accessories:

- 2, screws, #6 x 2.00 inch pan head
- 2, wall anchors suitable for the #6 screws

To install an AP-6511 Series Access Point to a wall surface:

1. Attach the metal mounting plate (shipped with the Access Point) to a wall surface at the desired deployment location.

The screws used to mount the bracket are customer provided and should be #6, with a 2.00 inch length.

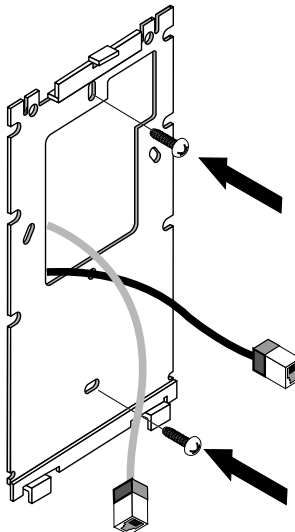

2. Connect one end of an RJ-45 cable into the wall mount connector on the Access Point as illustrated below.

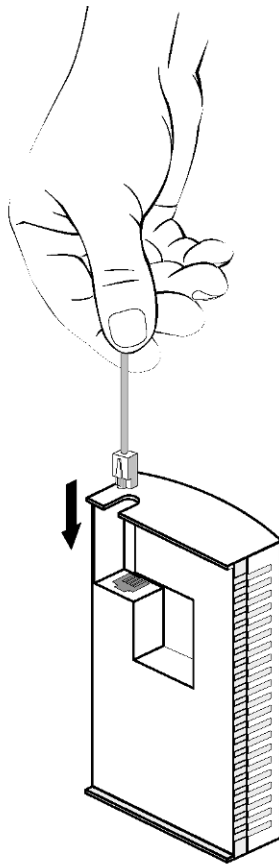

3. If using the optional second RJ-45 Ethernet port (utilizing a pass through keystone cable), ensure the following steps are completed:
 - a. Bend the cable into a “U” shape so the mini pin connector and the RJ-45 keystone cable are in close proximity to one another.
 - b. Install the mini pin connector into the pin socket on the back of the Access Point. The connector is keyed and can only be installed one way. Ensure the mini pin connector is connected securely.
 - c. Remove the blank plug from the keystone hole by gently pushing it out from the back.
 - d. Orient the RJ-45 keystone connector so the flexible keystone tab is away from the mini pin connector. Tip the keystone RJ-45 while installing in the keystone opening so the solid locking tabs engage, then rotate the RJ-45 forward until the tab snaps securely.

4. Snap the Access Point on to the mounted wall plate. Use the locking screw to secure the unit. This connection does not require the use of tools or fastening hardware.

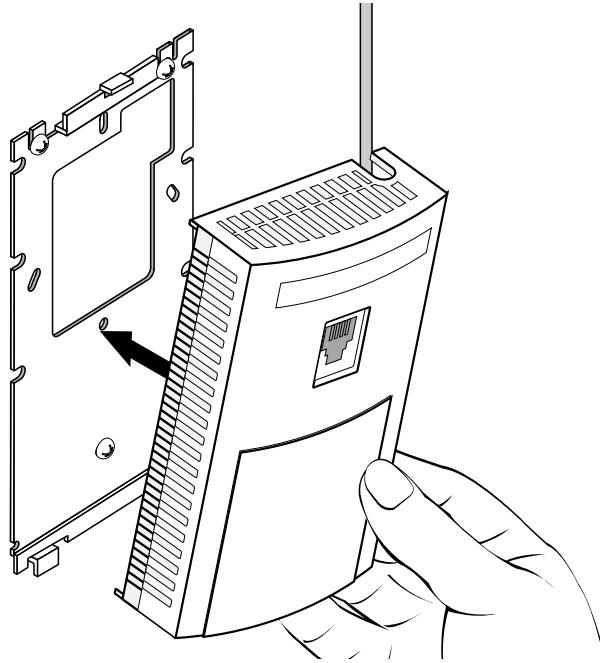

Once installed, connections are hidden from forward view, with only the physical infrastructure cables (Ethernet and power) extending from the Access Point.

5. Cable the Access Point using a Power Injector solution (AP-PSBIAS-2P2-AFR) as described in the following:
 - a. Connect an RJ-45 CAT5 Ethernet cable between the network data supply (host) and the Power Injector's **Data In** connector.
 - b. Connect an RJ-45 CAT5 Ethernet cable between the Power Injector's **Data & Power Out** connector and the Access Point.
 - c. Ensure the cable length from the Ethernet source (host) to the Power Injector and Access Point does not exceed 100 meters (333 ft). The Power Injector has no On/Off power switch. The Power Injector receives power as soon as AC power is applied. For more information, see [Power Injector System](#).
6. Verify the behavior of the Access Point LEDs. For more information, see [LED Indicators](#).
7. The Access Point is ready to configure. For information on basic Access Point device configuration, see [Basic Access Point Configuration](#).

2.6 Telco Box Installation

For Telco Box installations, the Access Point is installed directly over the standard wall plate supplying Ethernet. All cabled electrical connections are made within a recessed well in the housing of the Access Point.

To install the Access Point over a Telco box:

1. Remove the cover of the CAT5 wall plate.

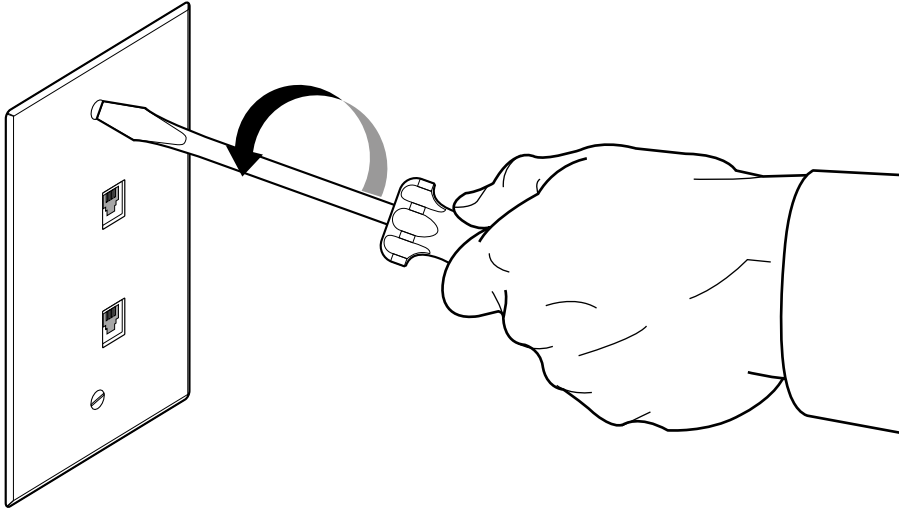

NOTE The example above assumes the Telco Box has a 1 RJ11 phonejack and 1 RJ-45 10/100 Ethernet connection.

2. Snap out keystone connectors from existing plate.
3. Gently pull some cable out of the wall so it can be used with the Access Point.
4. Attach the metal mounting plate (shipped with the Access Point) to an existing standard Telco in-wall box.

The screws used to mount the bracket to the Telco Box are customer provided. You can use the same screws that covered the existing wall plate if necessary.

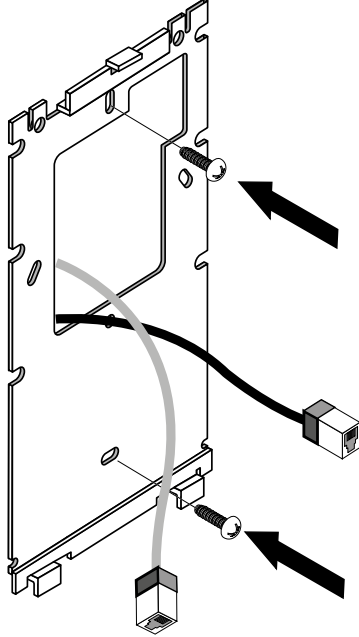

Mount the bracket to the wall so the Telco Box is ready available behind the mounting plate.

5. Remove the blank plug before installing the RJ11 into the snap-in port.

6. Install the RJ11 (keystone style) connector into the snap-in port.

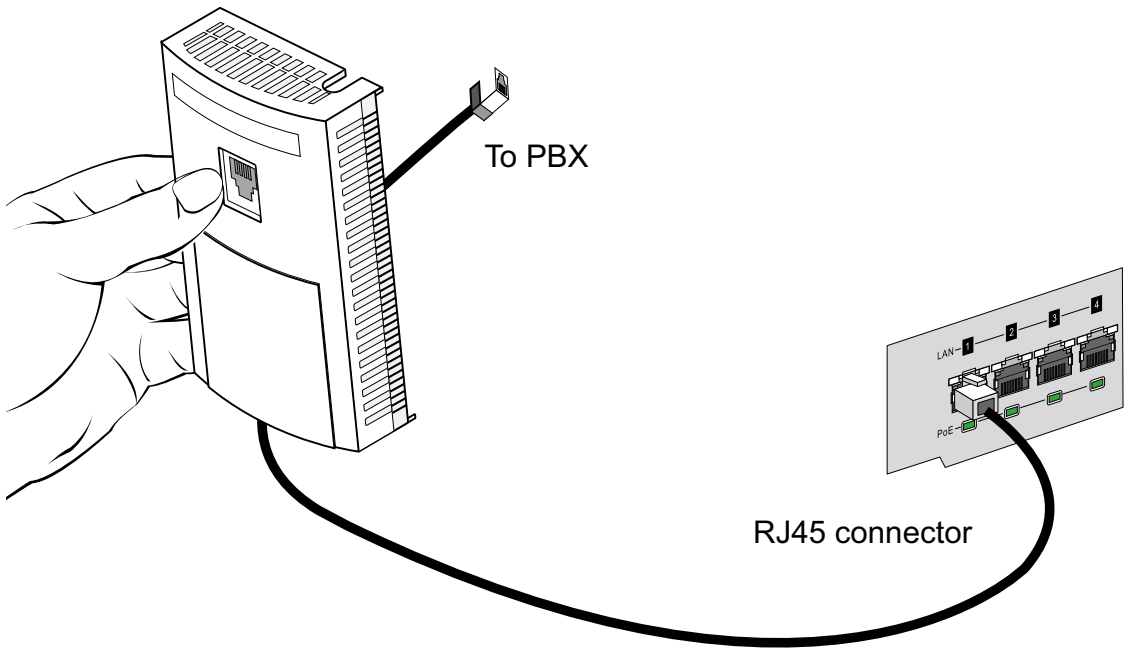

7. If using the optional second RJ-45 Ethernet port (utilizing a pass through keystone cable), ensure the following steps are completed:
 - a. Bend the cable into a "U" shape so the mini pin connector and the RJ-45 keystone cable are in close proximity to one another.
 - b. Install the mini pin connector into the pin socket on the back of the Access Point. The connector is keyed and can only be installed one way. Ensure the mini pin connector is connected securely.
 - c. Remove the blank plug from the keystone hole by gently pushing it out from the back.
 - d. Orient the RJ-45 keystone connector so the flexible keystone tab is away from the mini pin connector. Tip the keystone RJ-45 while installing in the keystone opening so the solid locking tabs engage, then rotate the RJ-45 forward until the tab snaps securely.
8. Install the RJ-45 double plug uplink jumper into the UP1/POE jack and connect it into the RJ-45 Ethernet connector.

9. Snap the Access Point on to the mounted wall plate and secure the Access Point using the mounting plate lock screw. This connection does not require the use of tools or fastening hardware.

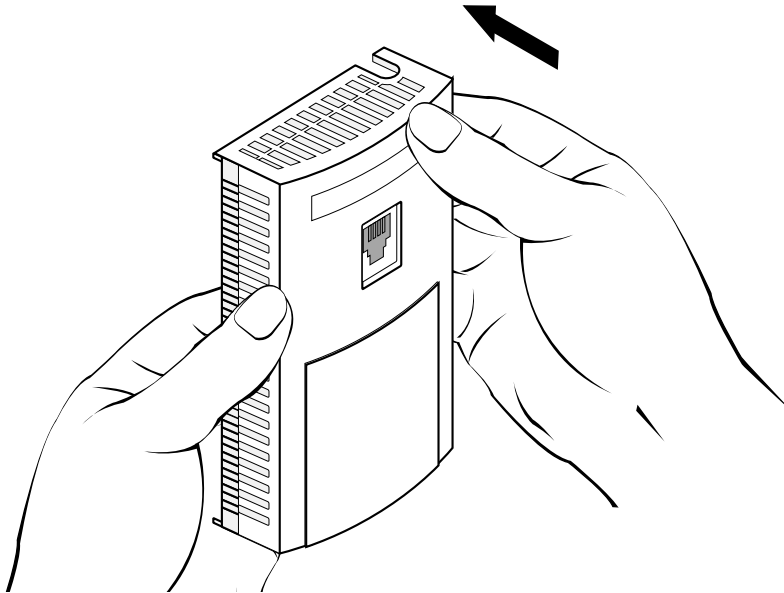

10. Cable the Access Point using a Power Injector solution (AP-PSBIAS-2P2-AFR) as described in the following:
 - e. Connect an RJ-45 CAT5 Ethernet cable between the network data supply (host) and the Power Injector's **Data In** connector.
 - f. Connect an RJ-45 CAT5 Ethernet cable between the Power Injector's **Data & Power Out** connector and the Access Point.
 - g. Ensure the cable length from the Ethernet source (host) to the Power Injector and Access Point does not exceed 100 meters (333 ft). The Power Injector has no On/Off power switch. The Power Injector receives power as soon as AC power is applied. For more information, see [Power Injector System](#).
11. Verify the behavior of the Access Point LEDs. For more information, see [LED Indicators](#).
12. The Access Point is ready to configure. For information on basic Access Point device configuration, see [Basic Access Point Configuration](#).

2.7 Antennas

An AP-6511 Series Access Point contains two internal (embedded) dual-band antennas supporting both the 802.11bgn (2.4 GHz) and 802.11an (5.0 GHz) bands. No customer assembly or antenna orientation is required.

The radio can transmit on one or two antennas depending on the operating modes. The radio can receive on one or two antennas as well. The data rates supported are different in each case.

2.8 LED Indicators

An AP-6511 Series Access Point has two LED activity indicators on the front of the unit.

The LEDs provide a status display indicating error conditions, transmission, and network activity for the 5 GHz 802.11a/n (amber) radio or the 2.4 GHz 802.11b/g/n (green) radio.

Task	5 GHz Activity LED (Amber)	2.4 GHz Activity LED (Green)
Unadopted	On	On
Normal Operation	<ul style="list-style-type: none"> • If this radio band is enabled: Blink at 5 second interval • If this radio band is disabled: Off • If there is activity on this band: Blink at a 1Hz 	<ul style="list-style-type: none"> • If this radio band is enabled: Blink at 5 second interval • If this radio band is disabled: Off • If there is activity on this band: Blink at a 1Hz
Firmware Update	On	Off
Locate AP Mode	Blink at 5Hz (Out of Phase with Activity LED)	Blink at 5Hz (Out of Phase with Activity LED)

3 Basic Access Point Configuration

Once the Access Point is installed and powered on, complete the following steps to get the device up and running and access management functions:

1. Attach an Ethernet cable from the Access Point to a controller with an 802.3af compatible power source or use the PWRS-14000-148R power supply to supply power to the Access Point (once fully cabled).

If your host system is a DHCP server, an IP address is automatically assigned to the Access Point and can be used for device connection. However, if a DHCP server is not available, you'll need to derive the IP address from the MAC address. Using this method, the last two bytes of the MAC address become the last two octets of the IP address. For example:

MAC address - 00:C0:23:00:F0:0A

Zero-Config IP address - 169.254.240.10

To derive the Access Point's IP address using its MAC address:

- a. Open the Windows calculator by selecting *Start > All Programs > Accessories > Calculator*. This menu path may vary slightly depending on your version of Windows.
 - b. With the Calculator displayed, select *View > Scientific*. Select the **Hex** radio button.
 - c. Enter a hex byte of the Access Point's MAC address. For example, F0.
 - d. Select the **Dec** radio button. The calculator converts F0 into 240. Repeat this process for the last Access Point MAC address octet.
2. Point the Web browser to the Access Point's IP address. The following login screen displays:

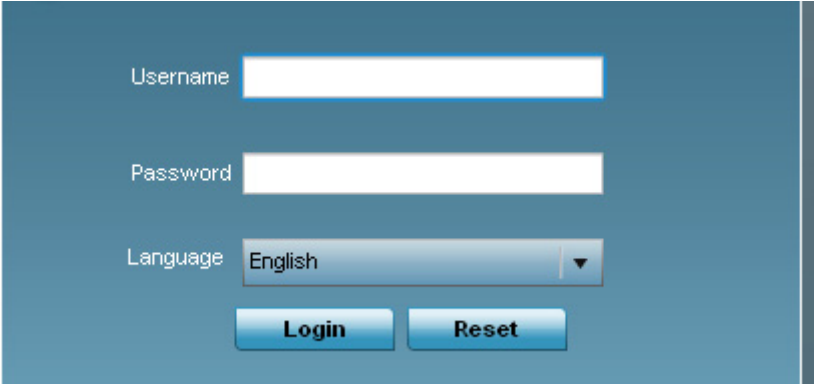

The image shows a login interface for an Access Point. It has a blue background. There are three input fields: 'Username', 'Password', and 'Language'. The 'Language' dropdown menu is currently set to 'English'. Below the input fields are two buttons: 'Login' and 'Reset'.

3. Enter the default username *admin* in the **Username** field.
4. Enter the default password *admin123* in the **Password** field.
5. Click the **Login** button to load the management interface.



NOTE When logging in for the first time, you're prompted to change the password to enhance device security in subsequent logins.



NOTE If you get disconnected when running the wizard, you can connect again with the Access Point's actual IP address (once obtained) and resume the wizard.

6. If this is the first time the management interface has been accessed, the Initial Setup Wizard automatically displays.



Function Highlight

- Access Point Types: Virtual Controller AP, Standalone AP, or Dependent AP
- Networking Mode: Bridge or Router Operation
- LAN Configuration
- Radio Configuration
- WAN Configuration
- Wireless LAN Setup
- Location, Country Code, Time Zone, Date and Time
- Summary and Save/Commit

Choose One Type to Setup the Access Point

- Typical Setup (Recommended)
 - The wizard uses as many default parameters as possible to simplify the configuration process.
- Advanced Setup
 - With this selection, you may configure the access point's LAN, WAN, Radio Mapping, Radius Server, WLAN, etc.



NOTE The Initial Setup Wizard displays the same content for each Access Point model supported. The only difference being the number of radios configurable by model.

The Introduction screen displays the various actions that can be performed using the wizard under the **Function Highlight** field.

Use the **Choose One type to Setup the Access Point** field options to select the type of wizard to run. The **Typical Setup** is the recommended wizard. This wizard uses the default parameters for most of the configuration parameters and sets up a working network with the least amount of manual configuration.

The **Advanced Setup** wizard is for administrators who prefer more control over the different configuration parameters. A few more configuration screens are available for customization when the Advanced Setup wizard is used.

The first page of the *Initial Setup Wizard* displays the **Navigation Panel** and **Function Highlights** for the configuration activities comprising the Access Point's initial setup. This page also displays options to select the typical or advanced mode for the wizard.

The Navigation Panel for the Typical Setup Wizard displays the basic configuration options.



A green checkmark to the left of an item in the **Navigation Panel** defines the task as having its minimum required configuration set correctly. A red X defines a task as still requiring at least one parameter be defined correctly.

7. Select **Save/Commit** within each page to save the updates made to that page's configuration. Select **Next** to proceed to the next page listed in the Navigation Panel without saving your updates.



NOTE While you can navigate to any page in the navigation panel, you cannot complete the Initial AP Setup Wizard until each task in the Navigation Panel has a green checkmark.

For the purposes of this guide, use the **Typical Setup (Recommended)** option to simplify the process of getting the Access Point up and running quickly with a minimum number of changes to the Access Point's default configuration.

For information on using the Access Point's Advanced Setup option, refer to the *WiNG Access Point System Reference Guide* to familiarize yourself with the feature set supported by the WiNG operating system. The guide is available at: www.zebra.com/support.

To configure the Access Point using the Typical Setup Wizard:

8. Select **Typical Setup** from the **Choose One type to Setup the Access Point** field on the Initial Setup Wizard.
9. The Typical Setup Wizard displays the **Access Point Settings** screen to define the Access Point's Standalone versus Virtual Controller AP functionality. This screen also enables selection of the country of operation for the Access Point.

Access Point Type Selection

- Virtual Controller AP - When more than one access point is deployed, a single access point can function as a Virtual Controller AP and manage Dependent mode access points. The Virtual Controller AP can adopt and configure other like APs in a 24-cell deployment.
- Standalone AP - Select this option to deploy this access point as an autonomous "fat" access point. A standalone AP isn't managed by a Virtual Controller AP, or adopted by a controller.

Country

10. Select an **Access Point Type** from the following options:
 - *Virtual Controller AP* - When more than one Access Point is deployed, a single Access Point can function as a Virtual Controller AP. Up to 24 Access Points can be connected to, and managed by, a single Virtual Controller AP of the same Access Point model. These connected Access Points must be the same model as the Virtual Controller AP.
 - *Standalone AP* - Select this option to deploy this Access Point as an autonomous fat Access Point.

A Standalone AP isn't managed by a Virtual Controller AP, or adopted by a controller.



NOTE If wanting to adopt the Access Point to a controller or service platform, use the controller or service platform's resident UI to connect to the Access Point, provision its configuration and administrate the Access Point's configuration.



NOTE If designating the Access Point as a Standalone AP, the Access Point's UI should be used to define its device configuration, and not the CLI. The CLI provides the ability to define more than one profile and the UI does not. Consequently, the two interfaces cannot be used collectively to manage profiles without an administrator encountering problems.

11. Select the **Country Code** of the country where the Access Point is deployed. Selecting a proper country is a critical task while configuring the Access Point, as it defines the correct channels of operation and ensures compliance to the regulations of the selected country. This field is only available for the Typical Setup Wizard.

12. Select **Next** to set the Access Point's network mode.

13. The Typical Setup Wizard displays the **Network Topology** screen to define how the Access Point handles network traffic.

Network Topology

- Router Mode - the access point routes traffic between the wireless network and the Internet or corporate network (WAN).

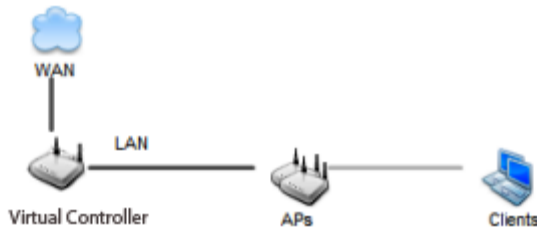

- Bridge Mode - In Bridge Mode, the access point depends on an external router for routing LAN and WAN traffic. Routing is generally used on one device, whereas bridging is typically used in a larger density network. Thus, select Bridge Mode when deploying this access point with numerous peer APs supporting clients on both the 2.4 and 5GHz radio bands.

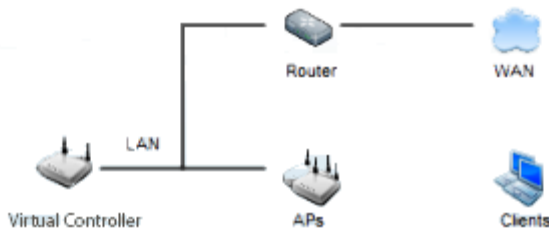

14. Select an Access Point Mode from the available options.

- *Router Mode* - In Router Mode, the Access Point routes traffic between the local network (LAN) and the Internet or external network (WAN). Router mode is recommended in a deployment supported by just a single Access Point.
- *Bridge Mode* - In Bridge Mode, the Access Point depends on an external router for routing LAN and WAN traffic. Routing is generally used on one device, whereas bridging is typically used in a larger density network. Select Bridge Mode when deploying this Access Point with numerous peer Access Points supporting clients on both the 2.4GHz and 5GHz radio bands.



NOTE When Bridge Mode is selected, WAN configuration cannot be performed and the Typical Setup Wizard does not display the WAN configuration screen.

15. Select **Next**. The Typical Setup Wizard displays the **LAN Configuration** screen to set the Access Point's LAN interface configuration.

LAN Configuration

Please configure interface settings for LAN (VLAN 1) which will be used by wireless clients

Use DHCP [What is this?](#)

Static IP Address/Subnet [What is this?](#) *

DHCP Server

Use on-board DHCP server to assign IP addresses to wireless clients

Range --

Default Gateway

Domain Name Server (DNS)

DNS Forwarding

Primary DNS

Secondary DNS

16. Set the following DHCP and Static IP Address/Subnet information for the LAN interface:
- *Use DHCP* - Select the checkbox to enable an automatic network address configuration using the Access Point's DHCP server.
 - *Static IP Address/Subnet* - Enter an IP Address and a subnet for the Access Point's LAN interface. If *Use DHCP* is selected, this field is not available. When selecting this option, define the following *DHCP Server* and *Domain Name Server (DNS)* resources, as those fields will become enabled on the bottom portion of the screen.
 - *Use on-board DHCP server to assign IP addresses to wireless clients* - Select the checkbox to enable the Access Point's DHCP server to provide IP and DNS information to clients on the LAN interface.
 - *Range* - Enter a starting and ending IP Address range for client assignments on the LAN interface. Avoid assigning IP addresses from x.x.x.1 - x.x.x.10 and x.x.x.255, as they are often reserved for standard network services. This is a required parameter.
 - *Default Gateway* - Define a default gateway address for use with the default gateway. This is a required parameter.

- *DNS Forwarding* - Select this option to allow a DNS server to translate domain names into IP addresses. If this option is not selected, a primary and secondary DNS resource must be specified. DNS forwarding is useful when a request for a domain name is made but the DNS server, responsible for converting the name into its corresponding IP address, cannot locate the matching IP address.
 - *Primary DNS* - Enter an IP Address for the main Domain Name Server providing DNS services for the Access Point's LAN interface.
 - *Secondary DNS* - Enter an IP Address for the backup Domain Name Server providing DNS services for the Access Point's LAN interface.
17. Select **Next**. The Typical Setup Wizard displays the **Wireless LAN Setup** screen to set the Access Point's Wireless LAN interface configuration.

WLAN 1
WLAN 2

 **WLAN 1 Configuration**

SSID [What is this?](#) *

WLAN Type No Authentication and No Encryption [What is this?](#)

Captive Portal Authentication and No Encryption [What is this?](#)

PSK authentication, WPA2 encryption [What is this?](#)

18. Set the following WLAN1 Configuration parameters:
- *SSID* - Configure the SSID for the WLAN.
 - *WLAN Type* - Configure the encryption and authentication to use with this WLAN.
 - *No Authentication and No Encryption* - Configures a network without any authentication. This option also configures the network without encryption. This means that any data transmitted through the network is in plain text. Any device between end points can see the information transmitted. This is the least secure of all network configurations.
 - *Captive Portal Authentication and No Encryption* - Configures a network that uses a RADIUS server to authenticate users before allowing them on to the network. Once on the network, no encryption is used for the data being transmitted through the network. Select this option to use a Web page (either internally or externally hosted) to authenticate users before access is granted to the network.
 - *PSK authentication, WPA2 encryption* - Configures a network that uses PSK authentication and WPA2 encryption. Select this option to implement a pre-shared key that must be correctly shared between the Access Point and requesting clients using this WLAN.

21. Select **Add User** to display the dialog to enter user information to add to the RADIUS server user database.

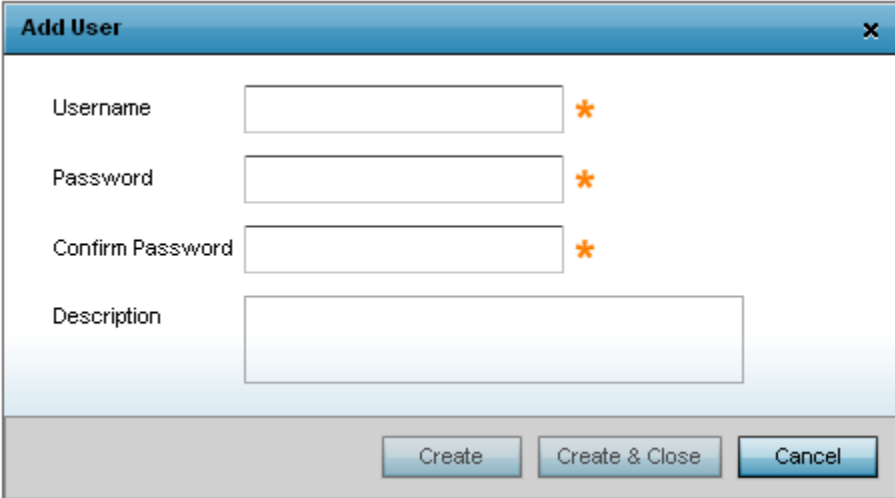

The screenshot shows a dialog box titled "Add User" with a close button (X) in the top right corner. The dialog contains four input fields: "Username", "Password", "Confirm Password", and "Description". Each of the first three fields has a red asterisk to its right, indicating they are required. At the bottom of the dialog, there are three buttons: "Create", "Create & Close", and "Cancel".

22. Enter the following user information:
 - *Username* - Provide a user name used to authenticate the user.
 - *Password* - Provide a password used to authenticate the user.
 - *Confirm Password* - Confirm the password by entering the same password as entered in the Password field.
 - *Description* - Provide a description to identify the user created in the RADIUS server database.
23. To create the entry in the RADIUS server database and add another user, select **Create**. To create the entry in the RADIUS server database and close the Add User dialog, select **Create & Close**.
24. Select **Modify User** on the RADIUS Server Configuration screen to modify information for an existing user from the RADIUS database. Highlight the user entry then select **Modify User**.



NOTE The *Username* cannot be modified with this dialog.

25. Select **Delete User** on the RADIUS Server Configuration screen to remove information for an existing user from the RADIUS database. Highlight the user entry and select **Delete User**.
26. Select **Confirm** on the dialog displayed. The entry for the user is removed from the RADIUS database.
27. To dismiss the dialog without adding, modifying or removing entries in the RADIUS server database, select **Cancel**.

28. Select **Next**. The Typical Setup Wizard displays the **Summary and Commit** screen to summarize the screens (pages) and settings updated using the Typical Setup Wizard.



Access Point Type Page

Access Point Type Standalone AP



Networking Mode Page

Networking Mode Router Mode



LAN Configuration Page

LAN Configuration Type Static IP Address/Subnet

VLAN ID for the LAN Interface 1

Static IP Address/Subnet 192.168.13.23/24



WAN Configuration Page

WAN Configuration Type Use DHCP

Port to External GE1 Port



WLAN Configuration

No user intervention or additional settings are required. Its an additional means of validating the Access Point's updated configuration before it's deployed. However, if a screen displays settings not intended as part of the initial configuration, then any screen can be selected again from within the Navigation Panel and its settings modified accordingly.

29. If the configuration displays as intended, select **Save/Commit** to implement these settings to the Access Point's configuration. If additional changes are warranted based on the summary, either select the target page from the **Navigation Panel**, or use the **Back** and **Next** buttons to scroll to the target screen.

4 Specifications

4.1 Electrical Characteristics

An AP-6511 Series Access Point has the following electrical characteristics:

Operating Current & Voltage 250mA@48VDC

4.2 Physical Characteristics

An AP-6511 Series Access Point has the following physical characteristics:

<i>Dimensions</i>	2.75 width x 5 height x 1.25 deep (Inches) 6.985 width x 12.7 height x 3.175 deep (centimeters)
<i>Housing</i>	Plastic and metal
<i>Weight</i>	0.5 lbs (with mounting plate)
<i>Operating Temperature</i>	32°F to 104°F/0°C to 40°C
<i>Storage Temperature</i>	-40°F to 158°F/-40°C to 85°C
<i>Operating Humidity</i>	5 to 95% Relative Humidity non-condensing
<i>Storage Humidity</i>	95% Relative Humidity non-condensing
<i>Operating Altitude (max)</i>	8,000 ft @ 28°C
<i>Storage Altitude (max)</i>	30,000 ft @ 12°C
<i>Electrostatic Discharge</i>	+/-8kV Air and +/-8kV Contact @ 50% Relative Humidity

4.3 Radio Characteristics

An AP-6511 Series Access Point has the following radio characteristics:

<i>Operating Channels</i>	2.4 GHz - Channels 1-13 5 GHz - Channels 36-64; channels 100 - 165 Actual operating frequencies depend on regulatory approval for the country of use.
<i>Data Rates Supported</i>	802.11b: 1Mbps, 2Mbps, 5.5Mbps and 11Mbps 802.11g: 6Mbps, 9Mbps, 12Mbps, 18Mbps, 24Mbps, 36Mbps, 48Mbps and 54Mbps 802.11n: MCS0 through MCS15, HT20 and HT40
<i>Wireless Medium</i>	<i>Direct Sequence Spread Spectrum</i> (DSSS), <i>Orthogonal Frequency Division Multiplexing</i> (OFDM) <i>Spatial multiplexing</i> (MIMO)
<i>Network Standards</i>	802.11a, 802.11b, 802.11g, 802.3, 802.11n (Draft 2.0)
<i>Maximum Available Transmit Power</i>	Maximum available conducted transmit power per chain: 2.4 GHz: 21dBm Maximum available conducted transmit power all chains: 2.4 GHz: 24dBm Maximum available conducted transmit power per chain: 5 GHz: 19dBm Maximum available conducted transmit power all chains: 5 GHz: 22dBm
<i>Transmit Power Adjustment</i>	1dB increments

5 Regulatory Information

5.1 Regulatory Overview

This guide applies to Model Number AP-6511.

All Zebra devices are designed to be compliant with rules and regulations in locations they are sold and will be labeled as required.

Local language translations are available at the following website: www.zebra.com/support.

Any changes or modifications to Zebra equipment, not expressly approved by Zebra, could void the user's authority to operate the equipment.

Zebra Access Points must be professionally installed and configured so that the Radio Frequency Output Power will not exceed the maximum allowable limit for the country of operation.

Antennas: Use only the supplied or an approved replacement antenna. Unauthorized antennas, modifications, or attachments could cause damage and may violate regulations. Use of an unapproved antenna is illegal under FCC regulations subjecting the end user to fines and equipment seizure.

5.2 Wireless Device Country Approvals

Regulatory markings, subject to certification, are applied to the device signifying the radio(s) is/are approved for use in the following countries: United States, Canada, Japan, China, S. Korea, Australia, and Europe.

Please refer to the *Declaration of Conformity* (DoC) for details of other country markings. This is available at www.zebra.com/doc

Note: For 2.4GHz or 5GHz Products: Europe includes, Austria, Belgium, Bulgaria, Czech Republic, Cyprus, Denmark, Estonia, Finland, France, Germany, Greece, Hungary, Iceland, Ireland, Italy, Latvia, Liechtenstein, Lithuania, Luxembourg, Malta, Netherlands, Norway, Poland, Portugal, Romania, Slovak Republic, Slovenia, Spain, Sweden, Switzerland and the United Kingdom.



Operation of the device without regulatory approval is illegal.

5.2.1 Country Selection – Note for AP & Wireless Controller

Select only the country in which you are using the device. Any other selection will make the operation of this device illegal. The US version of the Access Point will only have US listed in the country selection table. The US version will be sold / used in the US protectorates: American Samoa, Guam, Puerto Rico, US Virgin Islands.

5.2.2 Frequency of Operation – FCC and IC

5 GHz Only

The use on UNII (Unlicensed National Information Infrastructure) Band 1 5150-5250 MHz is restricted to indoor use only, any other use will make the operation of this device illegal.

Industry Canada Statement:

Caution: The device for the band 5150-5250 MHz is only for indoor usage to reduce potential for harmful interference to co-Channel mobile satellite systems. High power radars are allocated as primary users (meaning they have priority) of 5250-5350 MHz and 5650-5850 MHz and these radars could cause interference and/or damage to LE-LAN devices.

Avertissement: Le dispositif fonctionnant dans la bande 5150-5250 MHz est réservé uniquement pour une utilisation à l'intérieur afin de réduire les risques de brouillage préjudiciable aux systèmes de satellites mobiles utilisant les mêmes canaux. Les utilisateurs de radars de haute puissance sont désignés utilisateurs principaux (c.-à-d., qu'ils ont la priorité) pour les bands 5250-5350 MHz et 5650-5850 MHz et que ces radars pourraient causer du brouillage et/ou des dommages aux dispositifs LAN-EL.

2.4 GHz Only

The available channels for 802.11 b/g operation in the US are Channels 1 to 11. The range of channels is limited by firmware.

5.3 Health and Safety Recommendations



5.3.1 Warnings for the use of Wireless Devices

Please observe all warning notices with regard to the usage of wireless devices

5.3.2 Potentially Hazardous Atmospheres – Fixed Installations

You are reminded of the need to observe restrictions on the use of radio devices in fuel depots, chemical plants etc. and areas where the air contains chemicals or particles (such as grain, dust, or metal powders).

5.3.3 Safety in Hospitals

Wireless devices transmit radio frequency energy and may affect medical electrical equipment. When installed adjacent to other equipment, it is advised to verify that the adjacent equipment is not adversely affected.

Pacemakers

Pacemaker manufacturers recommended that a minimum of 15cm (6 inches) be maintained between a handheld wireless device and a pacemaker to avoid potential interference with the pacemaker. These recommendations are consistent with independent research and recommendations by Wireless Technology Research.

Persons with Pacemakers:

- Should ALWAYS keep the device more than 15cm (6 inches) from their pacemaker when turned ON.
- Should not carry the device in a breast pocket.
- Should use the ear furthest from the pacemaker to minimize the potential for interference.
- If you have any reason to suspect that interference is taking place, turn OFF your device.

Other Medical Devices

Please consult your physician or the manufacturer of the medical device, to determine if the operation of your wireless product may interfere with the medical device.

5.4 RF Exposure Guidelines

5.4.1 Safety Information

Reducing RF Exposure—Use Properly

Only operate the device in accordance with the instructions supplied.

5.5 International

The device complies with internationally recognized standards covering human exposure to electromagnetic fields from radio devices. For information on “International” human exposure to electromagnetic fields refer to the *Declaration of Conformity* (DoC) at www.zebra.com/doc.

5.6 EU

Remote and Standalone Antenna Configurations

To comply with EU RF exposure requirements, antennas that are mounted externally at remote locations or operating near users at stand-alone desktop of similar configurations must operate with a minimum separation distance of 20 cm from all persons.

5.7 US and Canada

Co-located statement

To comply with FCC RF exposure compliance requirement, the antennas used for this transmitter must not be co-located or operating in conjunction with any other transmitter/antenna except those already approved in this filling.

Remote and Standalone Antenna Configurations

To comply with FCC RF exposure requirements, antennas that are mounted externally at remote locations or operating near users at stand-alone desktop of similar configurations must operate with a minimum separation distance of 20 cm from all persons.

5.8 Power Supply

This device is powered from a 802.3af compliant power source which is UL approved and certified by the appropriate agencies.

5.9 Radio Frequency Interference Requirements—FCC



This equipment has been tested and found to comply with the limits for a Class B digital device, pursuant to Part 15 of the FCC rules. These limits are designed to provide reasonable protection against harmful interference in a residential installation. This equipment generates, uses and can radiate radio frequency energy and, if not installed and used in accordance with the instructions, may cause harmful interference to radio communications. However there is no guarantee that interference will not occur in a particular installation. If this equipment does cause harmful interference to radio or television reception, which can be determined by turning the equipment off and on, the user is encouraged to try to correct the interference by one or more of the following measures:

- Increase the separation between the equipment and receiver
- Connect the equipment into an outlet on a circuit different from that to which the receiver is connected
- Consult the dealer or an experienced radio/TV technician for help

Radio Transmitters (Part 15)

This device complies with Part 15 of the FCC Rules. Operation is subject to the following two conditions: (1) this device may not cause harmful interference, and (2) this device must accept any interference received, including interference that may cause undesired operation.

Restricted Band 5.60 – 5.65 GHz

5.10 Radio Frequency Interference Requirements – Canada

This Class B digital apparatus complies with Canadian ICES-003.

Cet appareil numérique de la classe B est conforme à la norme NMB-003 du Canada.

5.10.1 Radio Transmitters

For RLAN Devices:

The use of 5 GHz RLAN's, for use in Canada, have the following restrictions:

- Restricted Band 5.60 – 5.65 GHz

L'utilisation de RLAN de 5 GHz, pour utilisation au Canada est soumise aux restrictions suivantes:

- Bande Restreinte de 5,60 à 5,65 GHz

This device complies with RSS 210 of Industry & Science Canada. Operation is subject to the following two conditions: (1) this device may not cause harmful interference and (2) this device must accept any interference received, including interference that may cause undesired operation.

Ce dispositif est conforme à la norme CNR-210 d'Industrie Canada applicable aux appareils radio exempts de licence. Son fonctionnement est sujet aux deux conditions suivantes: (1) le dispositif ne doit pas produire de

brouillage préjudiciable, et (2) ce dispositif doit accepter tout brouillage reçu, y compris un brouillage susceptible de provoquer un fonctionnement indésirable

Label Marking: The Term "IC" before the radio certification only signifies that Industry Canada technical specifications were met.

5.11 CE Marking and European Economic Area (EEA)



The use of 2.4 GHz RLAN's, for use through the EEA, have the following restrictions:

- Maximum radiated transmit power of 100 mW EIRP in the frequency range 2.400 -2.4835 GHz.
- France, outside usage is restricted to 2.4 – 2.454 GHz.
- Italy requires a user license for outside usage.

5.12 Mexico

"La operación de este equipo está sujeta a lassiguientes dos condiciones: (1) es posible que este equipo o dispositivo no cause interferencia perjudicialy (2) este equipo o dispositivo debe aceptar cualquierinterferencia, incluyendo la que pueda causar suoperación no deseada."

5.13 Statement of Compliance

Zebra hereby declares that this device is in compliance with the essential requirements and other relevant provisions of Directive 1999/5/EC. A Declaration of Conformity may be obtained from www.zebra.com/doc.

5.14 Waste Electrical and Electronic Equipment (WEEE)



English: For EU Customers: All products at the end of their life must be returned to <https://portal.Zebra> for recycling. For information on how to return product, please go to: www.zebra.com/weee.

Français: Clients de l'Union Européenne: Tous les produits en fin de cycle de vie doivent être retournés à <https://portal.Zebra> pour recyclage. Pour de plus amples informations sur le retour de produits, consultez : www.zebra.com/weee.

Español: Para clientes en la Unión Europea: todos los productos deberán entregarse a <https://portal.Zebra> al final de su ciclo de vida para que sean reciclados. Si desea más información sobre cómo devolver un producto, visite: www.zebra.com/weee.

Български: За клиенти от ЕС: След края на полезния им живот всички продукти трябва да се връщат на <https://portal.Zebra> за рециклиране. За информация относно връщането на продукти, моля отидете на адрес: www.zebra.com/weee.

Deutsch: Für Kunden innerhalb der EU: Alle Produkte müssen am Ende ihrer Lebensdauer zum Recycling an <https://portal.Zebra> zurückgesandt werden. Informationen zur Rücksendung von Produkten finden Sie unter www.zebra.com/weee.

Italiano: per i clienti dell'UE: tutti i prodotti che sono giunti al termine del rispettivo ciclo di vita devono essere restituiti a <https://portal.Zebra> al fine di consentirne il riciclaggio. Per informazioni sulle modalità di restituzione, visitare il seguente sito Web: www.zebra.com/weee.

Português: Para clientes da UE: todos os produtos no fim de vida devem ser devolvidos a <https://portal.Zebra> para reciclagem. Para obter informações sobre como devolver o produto, visite: www.zebra.com/weee.

Nederlands: Voor klanten in de EU: alle producten dienen aan het einde van hun levensduur naar <https://portal.Zebra> te worden teruggezonden voor recycling. Raadpleeg www.zebra.com/weee voor meer informatie over het terugzenden van producten.

Polski: Klienci z obszaru Unii Europejskiej: Produkty wycofane z eksploatacji należą i zwrócić do firmy <https://portal.Zebra> w celu ich utylizacji. Informacje na temat zwrotu produktów znajdują się na stronie internetowej www.zebra.com/weee.

Čeština: Pro zákazníky z EU: Všechny produkty je nutné po skončení jejich životnosti vrátit společnosti <https://portal.Zebra> k recyklaci. Informace o způsobu vrácení produktu najdete na webových stránkách: www.zebra.com/weee.

Eesti: EL klientidele: kõik tooted tuleb nende eluea lõppedes tagastada taaskasutamise eesmärgil <https://portal.Zebra> ile. Lisainformatsiooni saamiseks toote tagastamise kohta külastage palun aadressi: www.zebra.com/weee.

Magyar: Az EU-ban vásárlóknak: Minden tönkrement termékét a <https://portal.Zebra> vállalathoz kell eljuttatni újrahasznosítás céljából. A termék visszajuttatásának módjával kapcsolatos tudnivalóért látogasson el a www.zebra.com/weee weboldalra.

Svenska: För kunder inom EU: Alla produkter som uppnått sin livslängd måste returneras till <https://portal.Zebra> för återvinning. Information om hur du returnerar produkten finns på www.zebra.com/weee.

Suomi: Asiakkait Euroopan unionin alueella: Kaikki tuotteet on palautettava kierrätettäväksi <https://portal.Zebra>-yhtiöön, kun tuotetta ei enää käytetä. Lisätietoja tuotteen palauttamisesta on osoitteessa www.zebra.com/weee

Dansk: Til kunder i EU: Alle produkter skal returneres til <https://portal.Zebra> til recirkulering, når de er udtjent. Læs oplysningerne om returnering af produkter på: www.zebra.com/weee.

Ελληνικά: Για πελάτες στην Ε.Ε.: Όλα τα προϊόντα, στο τέλος της διάρκειας ζωής τους, πρέπει να επιστρέφονται στην <https://portal.Zebra> για ανακύκλωση. Για περισσότερες πληροφορίες σχετικά με την επιστροφή ενός προϊόντος, επισκεφθείτε τη διεύθυνση www.zebra.com/weee στο Διαδίκτυο.

Malti: Għal klijenti fl-UE: il-prodotti kollha li jkunu waslu fl-aħħar tal-fajja ta' l-użu tagħhom, iridu jiġu rritornati għand <https://portal.Zebra> għar-riċiklaġġ. Għal aktar tagħrif dwar kif għandek tirritorna l-prodott, jekk jogħġbok żur: www.zebra.com/weee.

Românesc: Pentru clienții din UE: Toate produsele, la sfârșitul duratei lor de funcționare, trebuie returnate la <https://portal.Zebra> pentru reciclare. Pentru informații despre returnarea produsului, accesați: www.zebra.com/weee.

Slovenski: Za kupce v EU: vsi izdelki se morajo po poteku življenjske dobe vrniti podjetju <https://portal.Zebra> za reciklažo. Za informacije o vračilu izdelka obiščite: www.zebra.com/weee.

Slovenčina: Pre zákazníkov z krajín EU: Všetky výrobky musia byť po uplynutí doby ich životnosti vrátené spoločnosti <https://portal.Zebra> na recykláciu. Bližšie informácie o vrátení výrobkov nájdete na: www.zebra.com/weee.

Lietuvių: ES vartotojams: visi gaminiai, pasibaigus jų eksploatacijos laikui, turi būti gražinti utilizuoti į kompaniją „<https://portal.Zebra>“. Daugiau informacijos, kaip gražinti gaminių, rasite: www.zebra.com/weee.

Latviešu: ES klientiem: visi produkti pēc to kalpošanas mūža beigām ir jānogādā atpakaļ <https://portal.Zebra> otrreizējai pārstrādei. Lai iegūtu informāciju par produktu nogādāšanu <https://portal.Zebra>, lūdzu, skatiet: www.zebra.com/weee

Türkçe: AB Müşterileri için: Kullanım süresi dolan tüm ürünler geri dönüşürme için <https://portal.Zebra>'ya iade edilmelidir. Ürünlerin nasıl iade edileceği hakkında bilgi için lütfen şu adresi ziyaret edin: www.zebra.com/weee.

Turkish WEEE Statement of Compliance

EEE Yönetmeliğine Uygundur

5.15 Japan (VCCI) - Voluntary Control Council for Interference Class B ITE

この装置は、情報処理装置等電波障害自主規制協議会（VCCI）の基準に基づくクラスB情報技術装置です。この装置は、家庭環境で使用することを目的としています。この装置がラジオやテレビジョン受信機に近接して使用されると、受信障害を引き起こすことがあります。取扱説明書に従って正しい取り扱いをして下さい。

This is a Class B product based on the standard of the Voluntary Control Council for Interference from Information Technology Equipment (VCCI). If this is used near a radio or television receiver in a domestic environment, it may cause radio interference. Install and use the equipment according to the instruction manual.

5.16 Korea Warning Statement for Class B ITE

기종별	사용자안내문
B 급 기기 (가정용 방송통신기기)	이 기기는 가정용 (B 급) 으로 전자파적합등록을 한 기기로서 주로 가정에서 사용하는 것을 목적으로 하며, 모든 지역에서 사용할 수 있습니다.
Class B (Broadcasting Communication Device for Home Use)	This device obtained EMC registration mainly for home use (Class B) and may be used in all areas.

5.17 Other Countries

Australia

Use of 5 GHz RLAN's in Australia is restricted in the following band 5.50 – 5.65 GHz.

Brazil

Regulatory declarations for AP-6511 - BRAZIL

Note: The certification mark applied to the AP-6511 is for Restrict Radiation Equipment. This equipment operates on a secondary basis and does not have the right for protection against harmful interference from other users including same equipment types. Also this equipment must not cause interference to systems operating on primary basis.

For more information consult the website <http://www.anatel.gov.br>

Declarações Regulamentares para AP-6511 - Brasil

Nota: "A marca de certificação se aplica ao Transceptor, modelo AP-650. Este equipamento opera em caráter secundário, isto é, não tem direito a proteção contra interferência prejudicial, mesmo de estações do mesmo tipo, e não pode causar interferência a sistemas operando em caráter primário."

Para maiores informações sobre ANATEL consulte o site: <http://www.anatel.gov.br>

Chile

"Este equipo cumple con la Resolución No 403 de 2008, de la Subsecretaria de telecomunicaciones, relativa a radiaciones electromagnéticas."

"This device complies with the Resolution Not 403 of 2008, of the Undersecretary of telecommunications, relating to electromagnetic radiation."

Mexico

Restrict Frequency Range to: 2.450 – 2.4835 GHz.

Taiwan

NOTICE!

According to: Administrative Regulations on Low Power Radio Waves Radiated Devices

Article 12

Without permission granted by the DGT, any company, enterprise, or user is not allowed to change frequency, enhance transmitting power or alter original characteristic as well as performance to an approved low power radio-frequency devices.

Article 14

The low power radio-frequency devices shall not influence aircraft security and interfere legal communications; If found, the user shall cease operating immediately until no interference is achieved.

The said legal communications means radio communications is operated in compliance with the Telecommunications Act.

The low power radio-frequency devices must be susceptible with the interference from legal communications or ISM radio wave radiated devices Wireless device operate in the frequency band of 5.25-5.35 GHz, limited for Indoor use only.

臺灣

低功率電波輻射性電機管理辦法

第十二條

經型式認證合格之低功率射頻電機，非經許可，公司、商號或使用者均不得擅自變更頻率、加大功率或變更原設計之特性及功能。

第十四條

低功率射頻電機之使用不得影響飛航安全及干擾合法通信；經發現有干擾現象時，應立即停用，改善至無干擾時方得繼續使用。

前項合法通信，指依電信規定作業之無線電通信。

低功率射頻電機須忍受合法通信或工業、科學及醫療用電波輻射性電機設備之干擾。

在 5.25–5.35 赫頻帶內操作之無線資訊傳輸設備，限於室內使用。

Korea

For radio equipment using 2400~2483.5MHz or 5725~5825MHz, the following expressions should be displayed:

1. "This radio equipment can be interfered with during operation."

당해 무선설비는 운용 중 전파혼신 가능성이 있음

2. "This radio equipment cannot provide a service relevant to human life safety, as it can be crossed" through the user manual, etc.

당해 무선설비 는전파혼 신 가능성이 있으므로 인명안전과 관련된 서비스는 할 수 없습니다

6 Support

If you have a problem with your equipment, contact support for your region.

Contact information is available at: www.zebra.com/support

When contacting support, please provide the following information:

- Serial number of the unit
- Model number or product name
- Software type and version number

Support responds to calls by e-mail, telephone, or fax within the time limits set forth in support agreements. If you purchased your product from a business partner, contact that business partner for support.

6.1 Customer Support Web Sites

Support located at: www.zebra.com/support provides information and online assistance including developer tools, software downloads, product manuals and online repair requests.

6.2 Manuals

Documentation is available at: www.zebra.com/support.

7 AP-6511 Series Access Point China ROHS Compliance

部件名称 (Parts)	有害物质 					
	铅 (Pb)	汞 (Hg)	镉 (Cd)	六价铬 (Cr(VI))	多溴联苯 (PBB)	多溴二苯醚 (PBDE)
金属部件 (Metal Parts)	○	○	○	○	○	○
电路模块 (Circuit Modules)	X	○	○	○	○	○
电缆及电缆组件 (Cables and Cable Assemblies)	○	○	○	○	○	○
塑料和聚合物部件 (Plastic and Polymeric Parts)	○	○	○	○	○	○
光学和光学组件 (Optics and Optical Components)	○	○	○	○	○	○
电池 (Batteries)	○	○	○	○	○	○

本表格依据 SJ/T 11364 的规定编制。

○: 表示该有害物质在该部件所有均质材料中的含量均在 GB/T 26572 规定的限量要求以下。

X: 表示该有害物质至少在该部件的某一均质材料中的含量超出 GB/T 26572 规定的限量要求。(企业可在此处, 根据实际情况对上表中打“x”的技术原因进行进一步说明。)

This table was created to comply with China RoHS requirements for the AP-6511 Access Point.



Zebra Technologies Corporation
Lincolnshire, IL 60069 USA

Zebra and the Zebra head graphic are registered trademarks of ZIH Corp. The Symbol logo is a registered trademark of Symbol Technologies, Inc., a Zebra Technologies company.

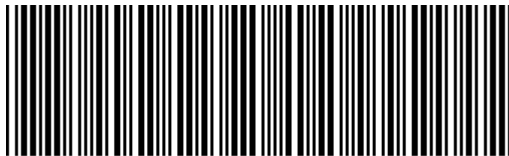

MN001363A01 Revision B April 2015

