



Quality Refrigeration

# OWNER'S MANUAL

Instructions for the installation  
and maintenance of most Traulsen models as well as  
instructions to operate the following special models:

**Blast Freezer Models**

RBF134HUT-FHS (formerly RIF134HUTBF) & RBF234HUT-FHS (formerly RIF234HUTBF)

**Fish File Models**

RFS126NUT, RFS226NUT & RFC232WSC

This Traulsen unit is built to our highest quality standards. We build our refrigerators, freezers and heated cabinets this way as a matter of pride. This philosophy has made Traulsen the leader in commercial refrigeration since 1938. We thank you for your choice and confidence in Traulsen equipment and we know you will receive many years of utility from this equipment.

All Traulsen units are placed on a permanent record file with the service department. In the event of any future questions you may have, please refer to the model and serial number found on the name tag affixed to the unit. Should you need service, however, call us on our toll free number, 800-825-8220 between 7:30 am and 4:30 pm CST, Monday thru Friday. It is our pleasure to help and assist you in every possible way.

**INSTALLER**

**COMPLETE THE FOLLOWING INFORMATION PRIOR TO UNIT INSTALLATION**

INITIAL START DATE: \_\_\_\_\_ SERIAL NO. \_\_\_\_\_

MODEL TYPE: \_\_\_\_\_

COMPANY/INDIVIDUAL NAME: \_\_\_\_\_

INSTALLER: \_\_\_\_\_

# TABLE OF CONTENTS



<b>I. THE SERIAL TAG</b>	Page 1	<b>VII. FISH FILE MODELS</b>	
<b>II. RECEIPT INSPECTION</b>	Page 2	a-Fish File Application	Page 6
<b>III. INSTALLATION</b>		b-Special Installation Note	Page 6
a-Location	Page 2	c-Drawer Pans	Page 6
b-Packaging	Page 2	d-Product Loading	Page 6
c-Installing Legs or Casters	Page 2	e-Cleaning	Page 6
d-Shelf Pins	Page 2	<b>VIII. BLAST FREEZER MODELS</b>	
e-Roll-In Model Installation	Page 3	a-Blast Freezer Application	Page 7
f-Installing The Condensate Evaporator	Page 3	b-Special Installation Note	Page 7
g-Remote Installation	Page 3	c-Interior Arrangements	Page 7
h-Cord & Plug	Page 3	d-Blast Freezing vs. Blast Chilling	Page 7
i-Power Supply	Page 4	e-Normal Operation	Page 7
j-Wiring Diagram	Page 4	f-Defrost	Page 7
k-Compressor Hold Down Provisions	Page 4	g-Blast Chill Operation	Page 7
l-Clearance	Page 4	h-Proper Packaging	Page 7
<b>IV. CARE &amp; MAINTENANCE</b>		<b>IX. STAINLESS STEEL OVERVIEW</b>	
a-Cleaning The Condenser	Page 4	a-Introduction	Page 8
b-Hinge Replacement	Page 4-5	b-Stainless Steel, How It Works	Page 8
c-Replacing The Gaskets	Page 5	c-Understanding The Causes of Corrosion	Page 8
d-Cleaning The Exterior	Page 5	<b>X. CARE OF STAINLESS STEEL</b>	
e-Cleaning The Interior	Page 5	a-Using The Proper Tools	Page 8
<b>V. MISC. OPERATIONS</b>		b-Using The Right Cleanser	Page 8
a-Adjusting The Shelves	Page 5	c-Cleaning Do's and Don'ts	Page 9
<b>VI. OTHER</b>		<b>XI. CORROSION REMEDIES</b>	
a-Service Information	Page 5	a-Dealing With Rust After The Fact	Page 9
b-Spare Parts	Page 5	b-Dealing With Extreme Rust Situations	Page 9
c-Warranty Registration	Page 5	c-Restoring The Protective Layer	Page 9
		<b>XII. TROUBLE SHOOTING GUIDE</b>	Page 10
		<b>XIII. WARRANTY INFORMATION</b>	Back Cover



FORT WORTH, TX.

<b>SERIAL</b>	<b>MODEL</b>	
<b>VOLTS</b>	<b>Hz</b>	<b>PH</b>
<b>TOTAL CURRENT</b>	<b>AMPS</b>	
<b>MINIMUM CIRCUIT</b>	<b>AMPS</b>	
<b>MAXIMUM OVERCURRENT PROTECTION</b>		<b>AMPS</b>
<b>LIGHTS</b>	<b>WATTS</b>	
<b>HEATERS</b>	<b>AMPS</b>	
<b>REFRIGERANT</b>		<b>TYPE</b>
<b>DESIGN PRESSURE</b>		<b>HIGH</b>
<b>REFRIGERANT</b>		<b>TYPE</b>
<b>DESIGN PRESSURE</b>		<b>HIGH</b>
		<b>OZ</b>
		<b>LOW</b>
		<b>OZ</b>
		<b>LOW</b>

370-60294-00 REV (A)

## I. THE SERIAL TAG

The serial tag is a permanently affixed sticker on which is recorded vital electrical and refrigeration data about your Traulsen product, as well as the model and serial number. This tag is located in the upper right interior compartment on all reach-in/pass-thru and roll-in/roll-thru refrigerator, freezer and dual-temp models. For hot food and proofer models, this tag is located on the top of the unit behind the louvers to protect it from the heat.

### READING THE SERIAL TAG

- Serial = The permanent ID# of your Traulsen
- Model = The model # of your Traulsen
- Volts = Voltage
- Hz = Cycle
- PH = Phase
- Total Current = Maximum amp draw
- Minimum Circuit = Minimum circuit ampacity
- Lights = Light wattage
- Heaters = Heater amperage (Hot Food units only)
- Refrigerant = Refrigerant type used
- Design Pressure = High & low side operating pressures and refrigerant charge
- Agency Labels = Designates agency listings

## II. RECEIPT INSPECTION

All Traulsen products are factory tested for performance and are free from defects when shipped. The utmost care has been taken in crating this product to protect against damage in transit. All interior fittings have been carefully secured and the legs or casters are boxed and strapped inside to prevent damage. Door keys will be attached to the handle with a nylon strip. The handle is protected by an easily removable nylon netting.

You should carefully inspect your Traulsen unit for damage during delivery. If damage is detected, you should save all the crating materials and make note on the carrier's Bill Of Lading describing this. A freight claim should be filed immediately. If damage is subsequently noted during or immediately after installation, contact the respective carrier and file a freight claim. Under no condition may a damaged unit be returned to Traulsen without first obtaining written permission (return authorization).

## III. INSTALLATION

### III. a - LOCATION:

Select a proper location for your Traulsen unit, away from extreme heat or cold. Allow enough clearance between the unit and the side wall in order to make use of the door stay open feature at 120° (self-closing feature operates up to 90°). The door(s) must be able to open a minimum of 90° in order to make use of the maximum clear door width available.

### III. b - PACKAGING:

All Traulsen units are shipped from the factory bolted to a sturdy wooden pallet and packaged in a durable cardboard container. The carton is attached to the wooden skid with the use of large staples. These should first be removed to avoid scratching the unit when lifting off the crate.

Most exterior stainless steel surfaces have a protective vinyl covering to prevent scratching during manufacturing, shipping and installation. After the unit is installed in place of service, remove and discard the covering from all surfaces.

To remove the wooden pallet, first if at all possible, we suggest that the cabinet remain bolted to the pallet during all transportation to the point of final installation. The bolts can then be removed with a 3/4" socket wrench. Avoid laying the unit on its front, side or back for removal of the pallet.

**NOTE:** Traulsen does not recommend laying the unit down on its front, side or back. However, if you must please be certain to allow the unit to remain in an upright position afterwards for 24 hours before plugging it in so that the compressor oils and refrigerant may settle.

## III. INSTALLATION (continued)

### III. c - INSTALLING LEGS OR CASTERS:

6" high stainless steel legs are supplied standard for all Traulsen reach-in and pass-thru units. Casters in lieu of legs are available as an optional accessory for the same models. These are shipped from the factory packed inside a cardboard box which is strapped to one of the shelves. Remove the nylon strap and open the box, it should contain either four (4) legs or four (4) casters and sixteen (16) bolts.

**WARNING: THE CABINET MUST BE BLOCKED AND STABLE BEFORE INSTALLING LEGS OR CASTERS.**

To install the legs or casters, first raise and block the reach-in a minimum of 7" from the floor. For installing legs, thread the legs into the threaded holes on the bottom of the cabinet (see figure 1). Be certain that all legs are tightly secured (legs and casters should be tightened to 300 inch/pounds, max). When the unit is set in its final position, it is important for proper operation that the unit be level. The legs are adjustable for this purpose, turn the bottom of the leg counter-clockwise to raise it, clockwise to lower it. Level the unit from front to back as well as side to side in this manner, using a level placed in the bottom of the cabinet.

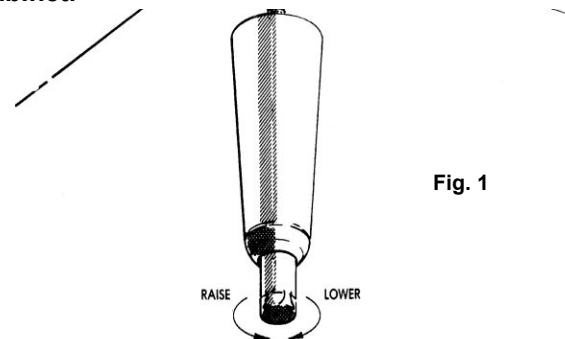

Fig. 1

Please note that Traulsen units are not designed to be moved while on legs. If the unit requires moving, a pallet jack or forklift should be used to prevent damage. For installing casters, the casters are "plate" type, and require the use of four (4) bolts each to secure them firmly to the cabinet bottom at each corner (see figure 2). The caster bolts are tightened using a 1/2" socket wrench.

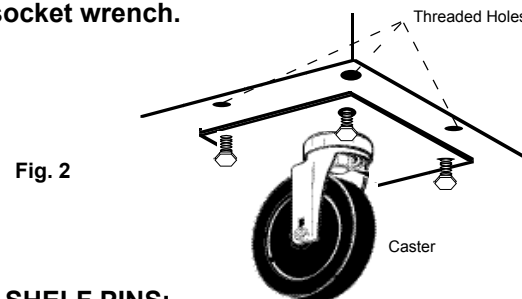

Fig. 2

### III. d - SHELF PINS:

The unit is supplied with shelves and shelf pins installed. Check all shelf pins to assure they are tightened down as they may have come loose during shipping. Rotate the pins clockwise until they are secured against the side of the cabinet.

### III. INSTALLATION (continued)

#### III. e - ROLL-IN MODEL INSTALLATION:

Roll-In cabinets set on the floor require the floor area to be flat and level. In addition, after the cabinet is set in place, sealant should be used around the perimeter of the base to comply with National Sanitation Foundation requirements (see figure 3). After sealing the unit, the enclosed ramp should then be installed.

SEALING BASE OF ROLL-IN MODELS

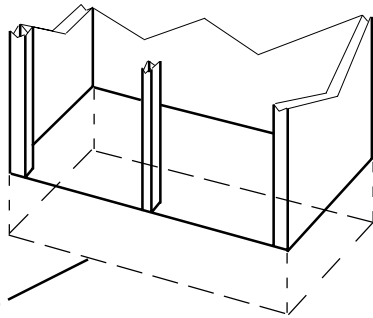

A SEALANT MUST BE USED AROUND THE PERIMETER OF THE BASE OF CABINET AS SHOWN TO FULLY COMPLY WITH SANITARY REQUIREMENTS.

A RECOMMENDED SEALANT IS DOW CORNING SILASTIC RTV #732

Fig. 3

A stainless steel threshold ramp(s) is included to facilitate rolling in racks. It is shipped wrapped in brown paper and secured to the rack guides inside the cabinet. To secure it in place, remove the two thumb screws in the breaker strip near the bottom door opening. Next, loosen the thumb screws located along the floor at the threshold. Place the ramp(s) on top of the loosened thumb screws and secure tabs on each end to breaker strips with thumb screws previously removed. After installing the ramp(s), it too should be sealed to the floor.

Bumper strips are secured to the back of Roll-In models with thumb screws. Loosen these and make them finger-tight to conform with the requirements of the National Sanitation Foundation (NSF).

#### III. f - INSTALLING THE CONDENSATE EVAPORATOR:

A condensate evaporator is normally supplied on all self-contained models (remote models require provision of either a floor drain or an optional condensate evaporator). On those models with the evaporator coil compartment located on the top of the unit, the condensate evaporator is also secured to the top of the cabinet. Check that the condensate pan is under the drain tube.

Some models, such as one-section dual-temperature reach-in refrigerator/freezers, are supplied with a bottom-mounted electric condensate evaporator. This is shipped in a cardboard carton secured to the cabinet interior, and must be installed prior to use.

After the cabinet has been uncrated and the legs/casters attached, you must install the bottom-mounted electric condensate evaporator. Locate the four (4)

#### III. f - INSTALLING THE CONDENSATE EVAP (cont'd):

holes on the exterior bottom towards the rear of the cabinet. Then, using the four (4) screws provided, attach the mounting rails to the cabinet bottom (the end flange is to be up and be facing towards the cabinet rear). Next, place the heater into the heater bracket (note the enclosed springs are only to be used when the heater is placed on the floor). Slide heater and bracket into the mounting rails. Plug the supplied cord into both the heater on one end, and the electrical outlet provided on the cabinet exterior bottom towards the front (see figure 4). Screw the "U-Trap" on to the drain line located on the rear of the cabinet and then screw the drain extension into the "U-Trap."

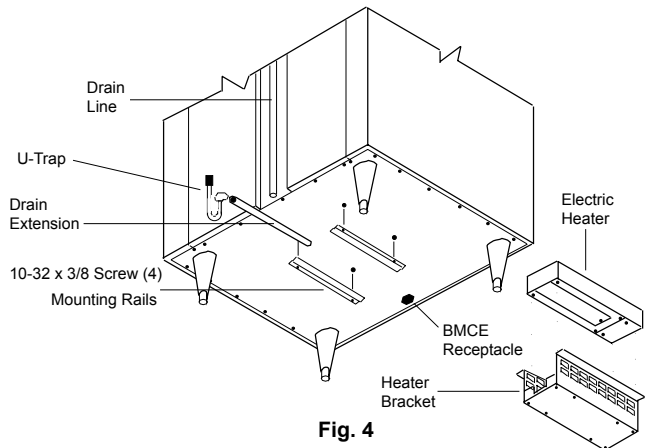

Fig. 4

A remote model is normally supplied configured for condensate to be run to a floor drain unless purchased with a condensate evaporator. The installer is responsible for making the required extension to the floor drain in accordance with good practice and local regulations.

#### III. g - REMOTE INSTALLATION:

Remote models are supplied without compressors, solenoid valves, etc. The correct voltage, amp listing and refrigerant are listed on the unit's serial tag. It is the responsibility of the installer to specify and supply the correct size compressor(s) based upon this information and on-site requirements. Refrigerant line installation must be done in accordance with good practice and local regulations. See section "III. g" for information concerning condensate removal for remote models.

#### III. h - CORD & PLUG:

Most self-contained models are supplied with a cord & plug attached. It is shipped coiled at the top of the cabinet, secured by a nylon strip. For your safety and protection, all units supplied with a cord and plug include a special three-prong grounding plug on the service cord. Select only a dedicated electrical outlet with grounding plug for power source. NOTE: Do not under any circumstances, cut or remove the round grounding prong from the plug, or use an extension cord.

### III. INSTALLATION (continued)

#### III. i - POWER SUPPLY:

The supply voltage should be checked prior to connection to be certain that proper voltage for the cabinet wiring is available (refer to the serial tag to determine correct unit voltage). Make connections in accordance with local electrical codes. Use qualified electricians.

Use of a separate, dedicated circuit is required. Size wiring to handle indicated load and provide necessary overcurrent protector in circuit (see amperage requirements on the unit's serial tag).

#### III. j - WIRING DIAGRAM:

Refer to the wiring diagram for any service work performed on the unit. Should you require one, please contact Traulsen Service at (800) 825-8220, and provide the model and serial number of the unit involved.

#### III. k - COMPRESSOR HOLD DOWN PROVISIONS:

To protect the compressor during transit, some self-contained Traulsen models have compressors tightened down at the factory. The hold down bolts used to tighten these must be loosened before operation to allow the vibration eliminators to function properly. Failure to loosen the hold down bolts could result in refrigerant line leakage, vibration and noise. Check the top to be sure all factory installed blocking (if used) is also removed. Likewise, check the compressor enclosure of bottom mounted units (RFD models) to be sure all packing is removed and that compressors secured to the base of condensing unit are free to operate on their vibration eliminators.

#### III. l - CLEARANCE:

In order to assure optimum performance, the condensing unit of your Traulsen unit **MUST** have an adequate supply of air for cooling purposes. Therefore, the operating location must either have a minimum of 12" clearance overhead of the condensing unit or allow for unrestricted air flow at the back of the unit. Clearance of at least 12" above is required in order to perform certain maintenance tasks.

### IV. CARE & MAINTENANCE

#### IV. a - CLEANING THE CONDENSER:

The most important thing you can do to insure a long, reliable service life for your Traulsen is to regularly clean the condenser coil.

The condensing unit requires regularly scheduled cleaning to keep the finned condenser clean of lint and dust accumulation. Keeping the condenser clean allows the cabinet to operate more efficiently and use less energy. To clean the condenser, first disconnect electrical power to the cabinet and lift up the front louver assembly. To lift this, remove the

### V. CARE & MAINTENANCE (cont'd)

#### IV. a - CLEANING THE CONDENSER (cont'd):

two screws located on both sides at the bottom of the louver assembly (see figure 6). Once the screws are removed, the panel can be pivoted upwards allowing full access to the front facing condenser (see figure 7). Vacuum or brush any dirt, lint or dust from the finned condenser coil, the compressor and other cooling system parts. If significant dirt is clogging the condenser fins, use compressed air to blow this clear.

Lower louver assembly and replace the screws to hold it in place.

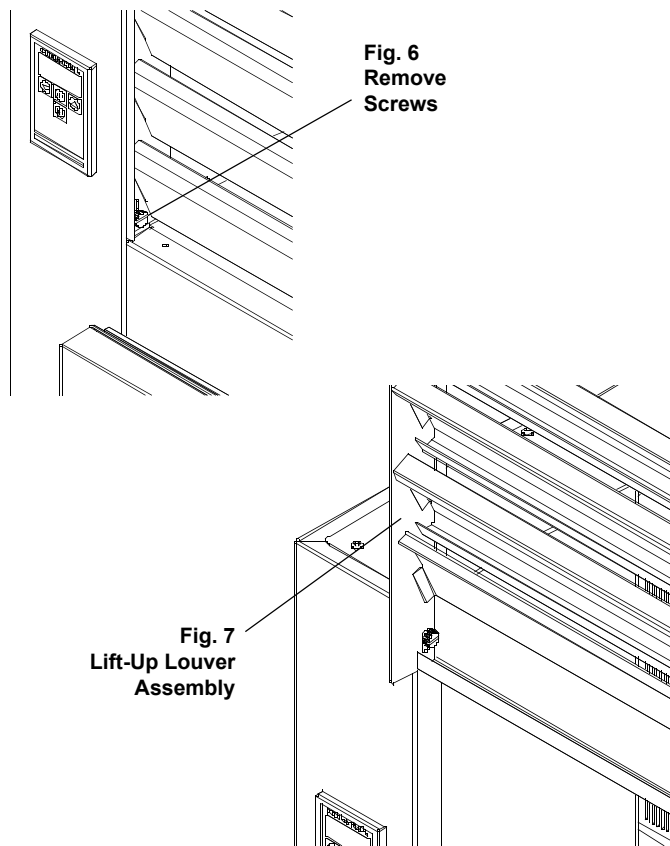

**WARNING: DISCONNECT ELECTRICAL POWER SUPPLY BEFORE CLEANING ANY PARTS OF THE UNIT.**

#### IV. b - HINGE REPLACEMENT:

Both the door and hinge can be easily removed from the cabinet. To remove the door, remove the plug at the bottom of the top hinge. Inside the hinge there is a small screw which secures the door in place. Remove this with a flat head screwdriver and the door can then be lifted off the hinge. To remove the door portion of the hinge from the door, lift off the hinge cover and then remove the three Phillips head screws which secure the hinge in place on the door. To remove the cabinet portion of the hinge, remove the three Phillips head screws which hold it in place. On solid

## IV. CARE & MAINTENANCE (cont'd)

### IV. b - HINGE REPLACEMENT:

door units, the top hinge(s) contains a microswitch for controlling the interior lighting.

To reassemble the hinge reverse the previous procedure.

### IV. c - REPLACING THE GASKETS:

To remove the gasket to be replaced, grasp it firmly by one corner and pull it out. Before attempting to install a new gasket, both the unit and the gasket itself must be at room temperature. Insert the four corners first by using a rubber mallet (or hammer with a block of wood). After the corners are properly inserted, work your way towards the center from both ends by gently hitting with a mallet until the gasket is completely seated in place (see figure 8 for proper gasket placement).

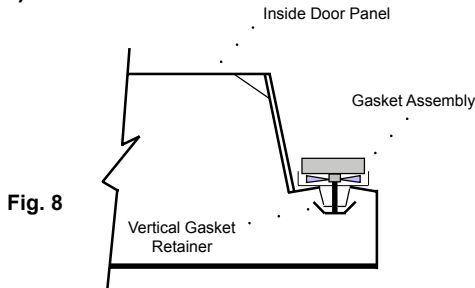

**NOTE:** The gasket may appear too large, but if it is installed as indicated above it will slip into place.

### IV. d - CLEANING THE EXTERIOR:

Exterior stainless steel should be cleaned with warm water, mild soap and a soft cloth. Apply with a dampened cloth and wipe in the direction of the metal grain.

Avoid the use of strong detergents and gritty, abrasive cleaners as they may tend to mar and scratch the surface. Do NOT use cleansers containing chlorine, this may promote corrosion of the stainless steel.

Care should also be taken to avoid splashing the unit with water, containing chlorinated cleansers, when mopping the floor around the unit.

For stubborn odor spills, use baking soda and water (mixed to a 1 TBSP baking soda to 1 pint water ratio).

### IV. e - CLEANING THE INTERIOR:

For cleaning both stainless steel and anodized aluminum interiors, the use of baking soda as described in section "IV. d" is recommended. Use on breaker strips as well as door gaskets. All interior fittings are removable without tools to facilitate cleaning.

## V. MISC. OPERATIONS

### V. a - ADJUSTING THE SHELVES:

For shelves mounted on pins, first select the desired location and remove the white plastic covers in the interior back and sides by rotating them counter-clockwise. Remove the shelf pins by rotating them counter-clockwise. Install the pins in the desired location by rotating clockwise. Make sure the pin is securely tightened down. Do not over tighten. Slide the shelf into its new position, and replace the white plastic covers into the holes vacated by the shelf pins.

## VI. OTHER

### VI. a - SERVICE INFORMATION:

Before calling for service, please check the following:

- Is the electrical cord plugged in?
- Is the fuse OK or circuit breaker on?
- Is the power switch "ON"?

If after checking the above items and the unit is still not operating properly, please contact an authorized Traulsen service agent. A complete list of authorized service agents was provided along with your Traulsen unit. If you cannot locate this, you may also obtain the name of a service agent from the Tech Service page of our website: [www.traulsen.com](http://www.traulsen.com).

If service is not satisfactory, please contact our in-house service department at:

Traulsen  
4401 Blue Mound Road  
Fort Worth, TX 76106  
(800) 825-8220

Traulsen reserves the right to change specifications or discontinue models without notice.

### VI. b - SPARE PARTS:

Spare or replacement parts may be obtained through a parts supplier or one of our authorized service agents. A complete list of authorized service agents accompanies this manual and is also posted on our company's official website @ [www.traulsen.com](http://www.traulsen.com).

### VI. c - WARRANTY REGISTRATION:

For your convenience, the warranties on your new Traulsen unit may be registered with us by one of two methods. Completing the enclosed warranty card (shipped with the unit), or by filling out the on-line warranty registration form located on the Technical Service page of our website ([www.traulsen.com](http://www.traulsen.com)).

## VII. SPECIALTY PRODUCTS - FISH FILE MODELS

### VII. a - FISH FILE APPLICATION:

Traulsen fish file models are specifically designed for the storage of fresh fish or poultry in a moist refrigerated environment, packed in crushed ice, thereby preventing dehydration and bacteria growth. For best results, product should be layered between ice starting and ending with a layer of ice. The normal operating temperature should be approximately 36° F, just right to prevent the ice from melting away too quickly. For temperature monitoring a digital thermometer is included (dial thermometer on model RFC232WSC).

### VII. b - SPECIAL INSTALLATION NOTE:

Installation should be performed as typical with any other model, see "Section III." However, a fish file requires provision of a floor drain for removing water resulting from the melted ice. The drain line should be located at the bottom of the cabinet. Connect this drain line to the floor drain using a 3/4" FPT connector (furnished) or equivalent depending on location. Close proximity of a hose reel or hose connection is helpful to wash out the unit.

**CAUTION:** An electric condensate evaporator cannot be used to dispose of water from melted ice.

### VII. c - DRAWER PANS:

Each fish file drawer is supplied with one (1) 16" wide by 18-7/8" long by 6-1/2" deep plastic pan, each pan contains a plastic perforated insert. When the ice melts, the resulting water drains through the perforated insert at the bottom of the pan into the drain port of the pan.

### VII. d - PRODUCT LOADING:

Product should be layered in ice, starting and ending with a layer of ice. The ice cools the product, keeping its surface moist and cleansing it as it slowly melts.

Fish and poultry should be held in separate units to avoid transferring odors.

Product should be removed for off hours storage.

### VII. e - CLEANING:

This unit should be cleaned on a daily basis. The entire interior should be sprayed with water. Both drawer pans and inserts should be thoroughly cleaned and sanitized each day.

The weep hole in the bottom of the drawer liner should be checked to make sure it remains clear, to drain excess moisture. Product should not be set in water.

Both drawer pans and inserts should be thoroughly cleaned and sanitized each day.

## VIII. SPECIALTY PRODUCTS - BLAST FREEZER MODELS

### VIII. a - BLAST FREEZER APPLICATION:

The roll-in blast freezer models were specifically designed for batch processing, where quick freezing of cooked product is required to help prolong shelf life.

### VIII. b - SPECIAL INSTALLATION NOTE:

Installation should be performed as typical with any other model, see "Section III." However, a blast freezer also requires provision of a floor drain for removing condensate. A floor mounted electric condensate evaporator is available from Traulsen as an optional accessory.

Additionally, these models do not include a cord and plug. Actual wiring to the power supply should be provided by a qualified electrician.

### VIII. c - INTERIOR ARRANGEMENTS:

Traulsen blast freezers are designed to accommodate 27" wide by 29" deep by 66" high roll-in racks (measurements with wheels inboard of frame). One section model accommodates one (1) roll-in rack. Two section model accommodates two (2) roll-in racks.

### VIII. d - BLAST FREEZING vs. BLAST CHILLING:

The Traulsen blast freezer models were designed to quickly freeze, and then hold, up to 200 lbs. of cooked product per batch. Length of a blast freeze cycle is preset by the operator using an manual timer.

By contrast, all Traulsen Blast chiller models are equipped with food probes and a microprocessor control, and designed to chill their respective capacity of product from 135° F down to 40° F in approximately 90 minutes.

These models do include a FREEZE CHILL feature, however this requires that product be removed at the end of this cycle as there are no provisions for holding frozen product (i.e. at the end of a FREEZE CHILL batch, the blast chiller reverts back to normal refrigerated storage temperatures).

### VIII. e - NORMAL OPERATION:

The blast freezer operates as a conventional freezer, maintaining temperatures of 0° to -5° F, when not in BLAST FREEZE MODE (i.e. with the blast freeze timer in the "OFF" position).

### VIII. f - DEFROST:

The cabinet has been shipped from the factory with three (3) timeclock defrost settings (12 midnight, 8 a.m. and 4 p.m.). For proper operation of the defrost system it is imperative that the timeclock be set to the correct time of day when the electrician makes the original installation. Similarly, if a power failure should occur, the timeclock must be reset after resumption of normal operation.

### The Blast Freezer Control

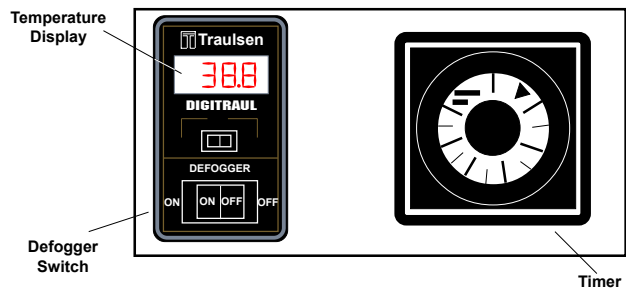

### VIII. g - BLAST FREEZE OPERATION:

To operate in BLAST FREEZE MODE, the blast freeze timer must be turned to the appropriate time period desired. In this mode, two (2) additional fans will operate in order to promote rapid freezing of the product and a secondary control assumes command of the condensing units so as to maintain cabinet air temperatures of -20° F.

Selecting the correct length of time required for blast freezing a particular product must be calculated by the operator. Freezing times will vary as a result of many factors, such as:

- Product Density
- Product Water/Fat Content
- Product Temperature
- Product Load
- Product Packaging & Spacing

All these factors need to be taken into account when determining the length of a blast freeze batch. We suggest that the operator begin a chart to record their own operational experience with frequently used loads and their respective freezing times.

### VIII. h - PROPER PACKAGING:

Packaging of food product is necessary to prevent dehydration, inhibit oxidation and allow accelerated heat transfer. This is due to the combination of high air velocities and cold temperatures required for blast freezing.

The particular type of packaging chosen should meet the following requirements:

- It **MUST** have the ability to withstand the temperature range through which it will pass (-20° F through to 400° F if also used for reheating).
- It **MUST** be protected against oxidation.
- It **MUST** have the ability to prevent dehydration.
- It **MUST** allow for rapid heat transfer to the food during freezing and reheating.



## IX. STAINLESS STEEL OVERVIEW

### IX. a - INTRODUCTION:

Most Traulsen models are constructed with a high quality 430 series, 20 gauge stainless steel exterior finish (front, sides and doors). The interior finish on these same models are constructed using 300 series stainless steel.

The stainless steel finish on Traulsen products should retain its appearance throughout the products usable life-time. However, some care is required to maintain this appearance. The following paragraphs will provide a guideline on proper care of the exterior/interior finish, as well as some suggestions on how to repair a finish which has been marred due to adverse environmental conditions or improper jobsite care.

### IX. b - STAINLESS STEEL, HOW IT WORKS:

The process by which stainless steel retains its appearance is a result of its type of metal alloy. Steel is a composite of metals combined in a specific industrial process. Stainless steel contains a high percentage of chromium, the addition of which provides both its appearance, and a microscopic surface layer protecting the steel underneath from corrosion. This external layer acts as a barrier, preventing typical oxidation of the steel. Remove this barrier, and the environment will eventually corrode the metal, marring its appearance.

### IX. c - UNDERSTANDING THE CAUSES OF CORROSION:

Corrosion to stainless steel can only be caused in one of four specific ways:

#### 1) **ABRASION**

Abrasion can be caused during routine cleaning of the metal, either by use of an abrasive cleanser, or use of an abrasive device, such as a metal scouring pad. Abrasion can also be caused by contact with other hard surfaces, such as nearby equipment, walls or tools. Special care should be taken to position your unit properly to prevent accidental dents and scratches.

#### 2) **WATER**

Water everywhere contains various deposits, or solids, which as the water dries or evaporates, can leave spots behind. The spots may eventually cause corrosion if not removed.

#### 3) **CHEMICALS OR WATER CONTAINING CHLORIDES**

Chlorides, such as found in water or many cleaning materials are especially corrosive to stainless steel. Daily janitorial duties, such as floor mopping, can splash water containing chlorinated cleansers against the front and sides of a Traulsen refrigeration product, resulting in corrosion. Avoid use of these on or around a Traulsen refrigeration product if at all possible.

#### 4) **PROLONGED CONTACT WITH FOOD PRODUCT**

Many food products, such as milk and carbonated sodas,

### IX. c - UNDERSTANDING THE CAUSES OF CORROSION:

contain acids which may damage the protective layer of stainless steel. All food and beverage spills should be cleaned up promptly to avoid possible stains and corrosion.

## X. CARE OF STAINLESS STEEL

### X. a - USING THE PROPER TOOLS:

Use of proper cleaning materials will do much to prolong the appearance of your Traulsen refrigeration product. We particularly encourage the use of either plastic scouring pads or soft cloths for cleaning stainless steel.

Soft nylon scouring pads can also be used, however care has to be used to insure that all scrubbing is done in the direction of the metals "GRAIN." Because metals are crystalline in nature, when they are in a solid state the individual ions line up to form visible grain lines. Use of a soft nylon scouring pad in a direction opposite of the grain will mar its luster. Always do so "PARALLEL" to the grain.

There are several types of tools which should **NEVER BE USED** when cleaning stainless steel, these include:

- WIRE BRUSHES
- METAL SCOURING PADS
- SANDPAPER
- SCRAPERS & PUTTY KNIVES

Use of any of these tools will result in scratches or removal of the stainless steel's protective layer, which will eventually lead to corrosion and rust.

### X. b - USING THE RIGHT CLEANSER:

Avoid all cleaning products containing chloride ingredients. Use of a cleanser specifically designed for stainless steel is highly recommended. You may find yourself in a situation where you are uncertain if a particular cleaning product contains any chlorides. If unsure, it's probably best to just assume that it does and avoid its use in cleaning a Traulsen refrigeration product.

Also to be avoided are cleaning products which contain "QUATERNARY SALTS." These salts can literally attack the stainless steel's protective layer, leading to corrosion and pitting of the steel's surface.

After cleaning, it is important to always rinse the cleaned area thoroughly with cool, clean water (do not use hot water) and wipe completely dry using a paper towel or soft absorbent cloth.

Use of cleaning products designed for use on stainless steel, in conjunction with the proper tools, as outlined above will help retain the appearance of your Traulsen refrigeration product for years and years.

## X. CARE OF STAINLESS STEEL (cont'd)

### X. c - CLEANING SUMMARY - DO'S & DONT'S:

To summarize the proper cleaning of Traulsen refrigeration products, always follow the below guidelines.

- DO use only cleaning products designed for stainless steel, or cleaning products which do not contain chlorides.
- DO use only non-abrasive cleaning materials, such as soft cloths or plastic scouring pads.
- DO clean-up food and beverage spills ASAP.
- DO scrub only in the direction of the grain when using soft nylon scouring pads.
- DON'T use chlorinated cleansers or cleansers containing quaternary salts.
- DON'T use abrasive cleaning materials or tools which can scratch the stainless steel's surface.

### X. d - DEALING WITH ACCIDENTAL CHLORIDE CONTACT:

In the daily routine of a busy foodservice operation, your Traulsen refrigeration product may occasionally come in contact with chlorinated cleaners, such as when being splashed during mopping. Stain and corrosion problems resulting from this can be avoided by prompt action to remove this cleanser. Rinse the affected area(s) thoroughly with cool, clean water (do not use hot water) and wipe completely dry using a paper towel or soft absorbent cloth.

### X. e - PROTECTING THE STAINLESS STEEL SURFACE:

Occasional use of a commercial stainless steel polish, such as "Sheila Shine," will help protect the surface of stainless steel. Follow the directions on the spray can for proper use.

## XI. CORROSION REMEDIES

### XI. a - DEALING WITH RUST AFTER THE FACT:

Although Traulsen strongly recommends proper care and cleaning of stainless steel finishes in order to avoid rust and corrosion before it occurs, we recognize that it may occur occasionally as a result of the causes described in section one of this booklet.

To remove small quantities of rust from the surface of stainless steel, it is far preferable to deal with this when it first becomes visible. When rust occurs, do not allow it to remain for any period of time, and remove it using the following method:

**STEP ONE** - Use a lightly abrasive compound (free of harmful chlorides), such as "Bon Ami," on a soft cloth, to remove the rust. Care must be taken to rub this on the area of rust only in the direction of the stainless steel's grain.

## XI. CORROSION REMEDIES

### XI. a - DEALING WITH RUST AFTER THE FACT (cont'd):

**STEP TWO** - Once the rust is removed, clean the affected area thoroughly with a stainless steel cleaner (see sections II. a & b).

**STEP THREE** - Apply a preservative polish, such as "Sheila Shine," to the affected area (see section II. e).

### XI. b - DEALING WITH EXTREME RUST SITUATIONS:

In the event that rust and corrosion were not dealt with promptly, more acute situations can be remedied as follows:

**NOTE: PROCEDURE REQUIRES USE OF AN ACID BASED SOLUTION - USE OF PROTECTIVE GLOVES AND EYEWEAR ARE REQUIRED BEFORE PROCEEDING**

**STEP ONE** - In a clean spray bottle combine water with "Zep FS Lime Remover" to make a 5 parts to 1 solution.

**STEP TWO** - Apply this solution to the affected area with either a clean cloth or sponge.

**STEP THREE** - After application, wipe the same area thoroughly clean with water only to remove any residue.

**STEP FOUR** - Once cleaned, apply a light coat of "Zep Restore" to the surface area. This will serve to preserve the metal and help prevent future rust from occurring.

**STEP FIVE** - Restore the remaining stainless steel surfaces to their original shine using "Zep Stainless Steel Polish."

Repeat steps one thru five if necessary for stubborn rust and corrosion areas.

### XI. c - RESTORING THE PROTECTIVE LAYER:

There are several products available on the market today which can actually help restore the "PASSIVATION" of stainless steel. "PASSIVATION" refers to the protective qualities of the non-reactive surface layer of stainless steel which prevents oxidation. Contact your cleaning supplier for product recommendations and more information.

## XI. TROUBLE SHOOTING GUIDE

FIND YOUR PROBLEM HERE	REMEDY
1. Condensing unit fails to start.	a. Check if cord & plug has been disconnected.
2. Condensing unit operates for prolonged periods or continuously.	a. Are doors closing properly? b. Dirty condenser or filter. Clean properly. c. Evaporator coil iced. Needs to defrost. d. Shortage of refrigerant, call service.
3. Food compartment is too warm.	a. Check door(s) and gasket(s) for proper seal b. Perhaps a large quantity of warm food has recently been added or the door was kept open for a long period of time, in both cases, allow adequate time for the cabinet to recover its normal operating temperature.
4. Food compartment is too cold.	a. Perhaps a large quantity of very cold or frozen food has recently been added. Allow adequate time for the cabinet to recover its normal operating temperature.
5. Condensation on the exterior surface.	a. Check door alignment and gaskets for proper seal. b. Condensation on the exterior surface of the unit is perfectly normal during periods of high humidity.
6. Compressor hums but does not start.	a. Call for service.

## XII. WARRANTY INFORMATION

### STANDARD DOMESTIC WARRANTY

TRAULSEN & CO., INC. warrants new equipment to the original purchaser, when installed within the United States against defective material and workmanship for one (1) year from the date of original installation. Under this warranty, TRAUlsen & CO., INC. will repair or replace, at its option, including service and labor, all parts found to be defective and subject to this warranty. The compressor part is warranted for an additional four (4) years. During this period TRAUlsen & CO., INC. will supply replacement compressor(s) if deemed defective, however, all installation, recharging and repair costs will remain the responsibility of the owner.

**This warranty does not apply to damage resulting from fire, water, burglary, accident, abuse, misuse, transit, acts of God, terrorism, attempted repairs, improper installation by unauthorized persons, and will not apply to food loss.**

THERE ARE NO ORAL, STATUTORY OR IMPLIED WARRANTIES APPLICABLE TO TRAUlsen, INCLUDING BUT NOT LIMITED TO, ANY IMPLIED WARRANTY OF MERCHANTABILITY OR FITNESS FOR ANY PARTICULAR PURPOSE WHICH EXTEND BEYOND THE DESCRIPTION ON THE FACE HEREOF. TRAUlsen SHALL HAVE NO OBLIGATION OR LIABILITY FOR CONSEQUENTIAL OR SPECIAL DAMAGES, GROWING OUT OF OR WITH RESPECT TO THE EQUIPMENT OR ITS SALE, OPERATION OR USE, AND TRAUlsen NEITHER ASSUMES NOR AUTHORIZES ANYONE ELSE TO ASSUME FOR IT ANY OBLIGATION OR LIABILITY IN CONNECTION WITH THE EQUIPMENT OR ITS SALE, OPERATION OR USE OTHER THAN AS STATED HEREIN.

### INTERNATIONAL COMMERCIAL WARRANTY

(for Canadian warranties see domestic US warranty)

TRAULSEN & CO., INC. warrants to the original purchaser the Refrigeration Equipment manufactured and sold by it to be free from defects in material and workmanship under normal use and service for a period of one (1) year from date of shipment. Under this warranty, TRAUlsen & CO., INC. will reimburse the purchaser for the replacement of any part of said equipment (excluding dryers & refrigerant gas) which then proves to be defective. **This warranty does not apply to damage resulting from fire, water, burglary, accident, abuse, misuse, transit, acts of God, terrorism, attempted repairs, improper installation by unauthorized persons, and will not apply to food loss.**

TRAULSEN'S standard warranty does not apply to Export Sales. Rather, for a period of one (1) year from date of original installation not to exceed Fifteen (15) months from date of shipment from factory, TRAUlsen:

will replace, F.O.B. factory, any defective parts normally subject to warranty.

will not cover the cost of packing, freight or labor such costs being the sole responsibility of the dealer.

**THIS WARRANTY IS IN LIEU OF ALL OTHER WARRANTIES EITHER EXPRESSED OR IMPLIED AND CONSTITUTES TRAUlsen'S FULL OBLIGATION AND LIABILITY. WARRANTIES NOT AVAILABLE ON REMOTE MODELS.**

#### HOURS OF OPERATION:

Monday thru Friday 7:30 am - 4:30 pm CST



Quality Refrigeration

**Traulsen**  
4401 Blue Mound Road Fort Worth, TX 76106  
Phone: (800) 825-8220 Fax-Svce: (817) 740-6757  
Website: [www.traulsen.com](http://www.traulsen.com)