

Ultra-Lite and Lite Qseven Carrier Boards

User Manual

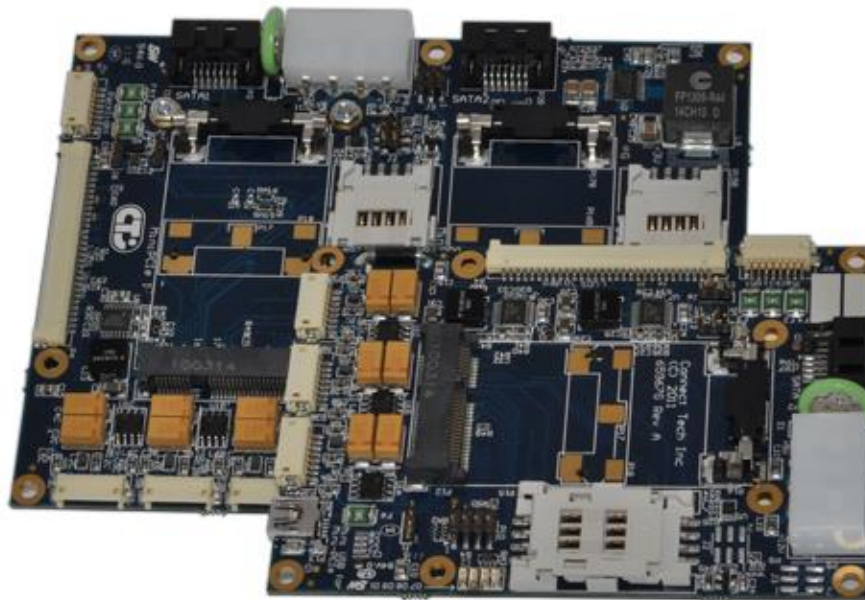

Connect Tech Inc.
42 Arrow Road
Guelph, Ontario
N1K 1S6

Tel: 519-836-1291
Toll: 800-426-8979 (North America only)
Fax: 519-836-4878
Email: sales@connecttech.com
support@connecttech.com
Web: www.connecttech.com

Table of Contents

Customer Support Overview	5
Contact Information.....	5
Limited Lifetime Warranty.....	6
Copyright Notice	6
Trademark Acknowledgment	6
Revision History	6
Introduction	8
What is Qseven?	8
ESD Warning.....	8
Product Features.....	9
System Block Diagram	10
Hardware Description.....	11
Ultra Lite Qseven Carrier Board Connector Locations	11
QCG005	11
QCG0011	11
QCG0015	12
Lite Connector and Jumper Summary.....	12
Lite Qseven Carrier Board Connector Locations	13
Lite – Bottom	13
Lite Connector and Jumper Summary.....	14
Ultra-Lite Carrier Connector Descriptions	15
Qseven Module Interface	15
Description.....	15
Connector.....	15
Video.....	15
HDMI	15
LVDS	16
Description.....	16
LVDS Video Header.....	16
LVDS Backlight.....	17
LVDS Backlight connector.....	17
LVDS Backlight Power Jumper	17
Power for LVDS Panel Circuits	17
LVDS backlight enable polarity.....	18
USB Operations	19
User USB Ports	19
Connector.....	19
USB Ports on MiniPCIe connectors	19
RS232 Serial	20
Description.....	20
Connector & Jumper	20
SATA.....	21
Description.....	21
Connector & LEDs	21
miniPCIe	22
miniPCIe SIM Card	22
miniPCIe WiFi Status LEDs	23

miniPCIe WiFi Jumpers	23
Off board status LEDs.....	23
Ultra Lite Version	23
<i>Note: Odd pins are connected to 3.3V or 5V with a 470ohm resistor</i> Micro SD Card.....	23
Description.....	24
Power	25
Description.....	25
Power Connectors	25
+5VSB Jumper (QCG005 Only, QCG011/QCG015 permanently connect +5V SB to +5V)	26
Power Good Jumper.....	26
Module Current Requirements	26
Current Consumption information	26
J3 Miscellaneous Functions	27
UltraLite Carrier Hardware Installation	28
Lite Carrier Connector Descriptions.....	29
Qseven Module Interface	29
Description.....	29
Connector.....	29
Video.....	29
HDMI.....	29
LVDS	30
Description.....	30
LVDS Video Header.....	30
LVDS Backlight.....	31
LVDS Backlight connector.....	31
LVDS Backlight Power Jumper	31
Power for LVDS Panel Circuits	31
LVDS backlight enable polarity.....	32
USB Operations	32
User USB Ports	32
Connector.....	32
USB Client/Host Port Mode.....	33
USB Client Host Operation.....	33
USB Ports on MiniPCIe connectors.....	33
RS232 Serial	34
Description.....	34
Connector & Jumper	34
SATA.....	35
Description.....	35
Connector & LEDs	35
miniPCIe.....	36
miniPCIe SIM Card	36
miniPCIe WiFi Status LEDs	37
Off board status LEDs.....	37
Battery and I2C Interface	38
Partial Schematic.....	38
Debug JTAG and RS232 on Lite Version	39
Circuit Schematic	39
Micro SD Card	40
Description.....	40
Power	41
Description.....	41
Power Connectors	41

+5VSB Jumper.....	41
Power Good Jumper.....	42
Module Current Requirements.....	42
Current Consumption information.....	42
J3 Miscellaneous Functions.....	42
Lite Carrier Hardware Installation.....	43
Software Installation & Configuration.....	44
Operating System Notes.....	44
Linux.....	44
US15W Specific.....	44
Windows.....	44
US15W Specific.....	44
Cables & Interconnect.....	45
Dimensions Ultra Lite Qseven Carrier Boards.....	46
Dimensions Lite Qseven Carrier Board.....	47
Part Numbers.....	48

Customer Support Overview

If you experience difficulties after reading the manual and/or using the product, contact the Connect Tech reseller from which you purchased the product. In most cases the reseller can help you with product installation and difficulties.

In the event that the reseller is unable to resolve your problem, our highly qualified support staff can assist you. Our support section is available 24 hours a day, 7 days a week on our website at: www.connecttech.com/sub/support/support.asp. See the contact information section below for more information on how to contact us directly. Our technical support is always free.

Contact Information

We offer three ways for you to contact us:

Mail/Courier

You may contact us by letter at:
Connect Tech Inc.
Technical Support
42 Arrow Road
Guelph, Ontario
Canada N1K 1S6

Email/Internet

You may contact us through the Internet. Our email and URL addresses on the Internet are:

sales@connecttech.com
support@connecttech.com
www.connecttech.com

Note:

Please go to the [Download Zone](#) or the [Knowledge Database](#) in the [Support Center](#) on the Connect Tech website for product manuals, installation guides, device driver software and technical tips. Submit your technical support questions to our customer support engineers via the [Support Center](#) on the Connect Tech website.

Telephone/Facsimile

Technical Support representatives are ready to answer your call Monday through Friday, from 8:30 a.m. to 5:00 p.m. Eastern Standard Time. Our numbers for calls are:

Toll Free: 800-426-8979 (North America only)
Telephone: 519-836-1291 (Live assistance available 8:30 a.m. to 5:00 p.m. EST, Monday to Friday)
Facsimile: 519-836-4878 (on-line 24 hours)

Limited Lifetime Warranty

Connect Tech Inc. provides a Lifetime Warranty for all Connect Tech Inc. products. Should this product, in Connect Tech Inc.'s opinion, fail to be in good working order during the warranty period, Connect Tech Inc. will, at its option, repair or replace this product at no charge, provided that the product has not been subjected to abuse, misuse, accident, disaster or non-Connect Tech Inc. authorized modification or repair.

You may obtain warranty service by delivering this product to an authorized Connect Tech Inc. business partner or to Connect Tech Inc. along with proof of purchase. Product returned to Connect Tech Inc. must be pre-authorized by Connect Tech Inc. with an RMA (Return Material Authorization) number marked on the outside of the package and sent prepaid, insured and packaged for safe shipment. Connect Tech Inc. will return this product by prepaid ground shipment service.

The Connect Tech Inc. Lifetime Warranty is defined as the serviceable life of the product. This is defined as the period during which all components are available. Should the product prove to be irreparable, Connect Tech Inc. reserves the right to substitute an equivalent product if available or to retract Lifetime Warranty if no replacement is available.

The above warranty is the only warranty authorized by Connect Tech Inc. Under no circumstances will Connect Tech Inc. be liable in any way for any damages, including any lost profits, lost savings or other incidental or consequential damages arising out of the use of, or inability to use, such product.

Copyright Notice

The information contained in this document is subject to change without notice. Connect Tech Inc. shall not be liable for errors contained herein or for incidental consequential damages in connection with the furnishing, performance, or use of this material. This document contains proprietary information that is protected by copyright. All rights are reserved. No part of this document may be photocopied, reproduced, or translated to another language without the prior written consent of Connect Tech, Inc.

Copyright © 1997 - 2013 by Connect Tech, Inc.

Trademark Acknowledgment

Connect Tech, Inc. acknowledges all trademarks, registered trademarks and/or copyrights referred to in this document as the property of their respective owners.

Not listing all possible trademarks or copyright acknowledgments does not constitute a lack of acknowledgment to the rightful owners of the trademarks and copyrights mentioned in this document.

Revision History

Rev	Date	Change
0.00	June 3, 2011	Original Document
0.01	Oct 3, 2012	Updated features for QCG006 including GBE, JTAG, USB Client/Host, and RS232.
0.02	April 3, 2013	Added information on QCG011/12
0.03	Oct 24, 2013	Split Ultra Lite and Lite Carrier information, added QCG015

Introduction

Connect Tech's Ultra Lite and Lite Qseven Carrier Boards are small low cost, feature rich carriers that integrate with any industry standard Qseven module. These bus-independent carrier boards offer easy connection to SATA, USB, Ethernet, LVDS and VGA video, and RS-232 with Mini-PCIe and SIM-card expansion capability. Mini-PCIe peripherals such as WiFi, GPS, Bluetooth, or storage are optional. Ultra Lite and Lite Qseven Carrier Boards offer several processor options including Intel® Atom™, Freescale i.MX51, TI OMAP, and NVIDIA Tegra, which are easily upgradable to accommodate future generations.

Connect Tech's Qseven carrier boards are ideal for compact computing applications in mobile entertainment, kiosks, digital signage, soldier wearable systems and gaming.

What is Qseven?

Qseven is an off-the-shelf, multi-vendor, computer-on-module that integrates the core components of a common PC. The Qseven standard allows upgrading to the latest processor and memory technology with ease, while maintaining the I/O interfaces.

To learn more about Connect Tech's Qseven carrier, visit <http://www.connecttech.com/Qseven>.

ESD Warning



Electronic components and circuits are sensitive to ElectroStatic Discharge (ESD). When handling any circuit board assemblies including Connect Tech Qseven carrier assemblies, it is recommended that ESD safety precautions be observed. ESD safe best practices include, but are not limited to:

- Leaving circuit boards in their antistatic packaging until they are ready to be installed.
- Using a grounded wrist strap when handling circuit boards, at a minimum you should touch a grounded metal object to dissipate any static charge that may be present on you.
- Only handling circuit boards in ESD safe areas, which may include ESD floor and table mats, wrist strap stations and ESD safe lab coats.
- Avoiding handling circuit boards in carpeted areas.
- Trying to handle the board by the edges, avoiding contact with components.

Product Features

Feature	Ultra Lite Qseven Carrier			Lite Qseven Carrier
	QCG005	QCG011	QCG015	QCG006
Part Number	QCG005	QCG011	QCG015	QCG006
Size	Pico ITX, 72x100mm	Pico ITX, 72x100mm	Pico ITX, 72x100mm	128x100mm
Mini-PCIe Expansion	1	1	-	2
mSATA Expansion	-	-	1	-
SIM Card Connector	1	1	-	2
USB on MiniPCIe	-	Yes	-	Yes
LVDS Video & Backlight controls	Yes	Yes	Yes	Yes
HDMI Video/Audio	-	-	Yes	Yes
JTAG/RS232 Debug	-	-	-	Yes
Battery I2C Interface	-	-	-	Yes
Giga Bit Ethernet	-	Yes	Yes	Yes
USB Client Port	-	Yes	Yes	Yes ^[1]
USB Ports	4	4	4	4 ^[1]
SATA Ports	1	1	1	2
RS232 Serial Port	-	-	Yes	Y ^[1]
SD Card	-	-	MicroSD	MicroSD
RTC 3.3V Battery	Yes	Yes	Yes	Yes
Power Connectors • Molex HDD • Screw Terminal	Yes Optional	Yes Optional	Optional Yes	Yes Optional
Accessories	Optional cable kit	Optional cable kit	Optional cable kit	Optional cable kit

^[1]The RS232 serial port and the USB Client/Host port are shared with the USB Ports.

System Block Diagram

Atom based Qseven modules implement the core processing features including: processor, memory, and system physical interfaces via the south bridge.

Many of the Qseven modules are based on the mobile Intel® Atom™ architecture (Z series processor + SCH US15W chipset), shown in the block diagram below.

This document will generally refer to the features of the US15W.

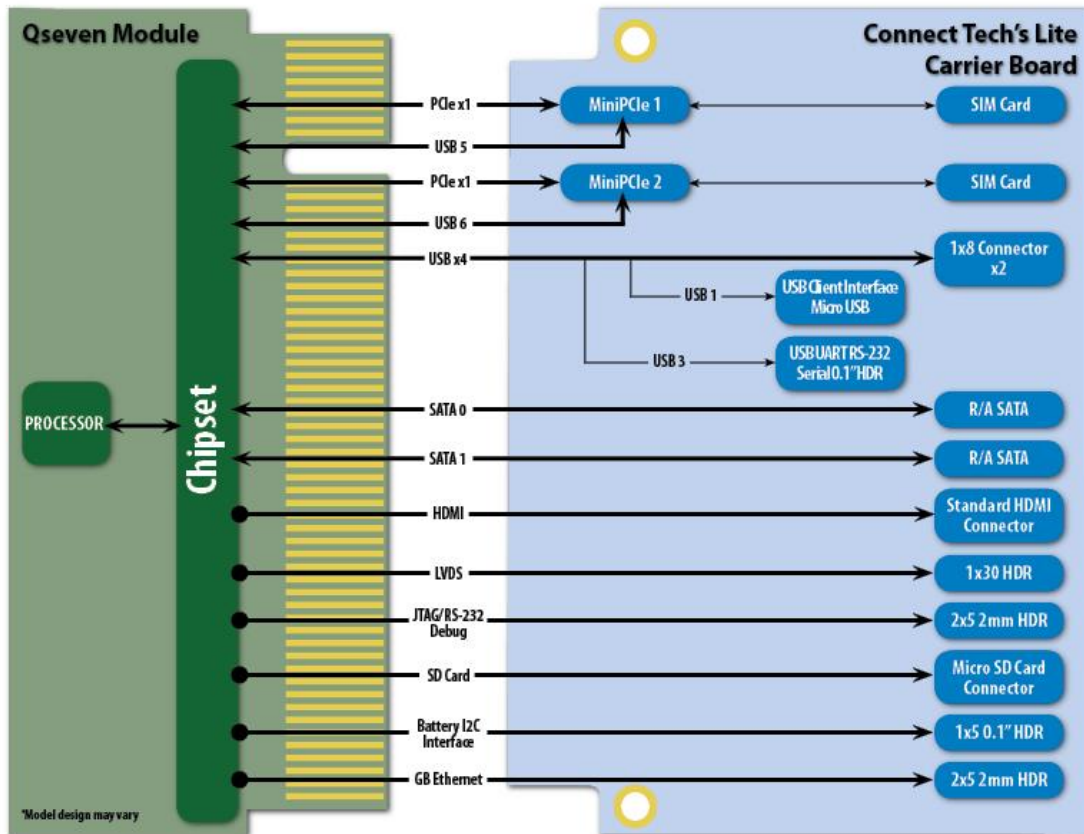

Note: Some features shown above may not be present on all part numbers.

Hardware Description

Ultra Lite Qseven Carrier Board Connector Locations

QCG005

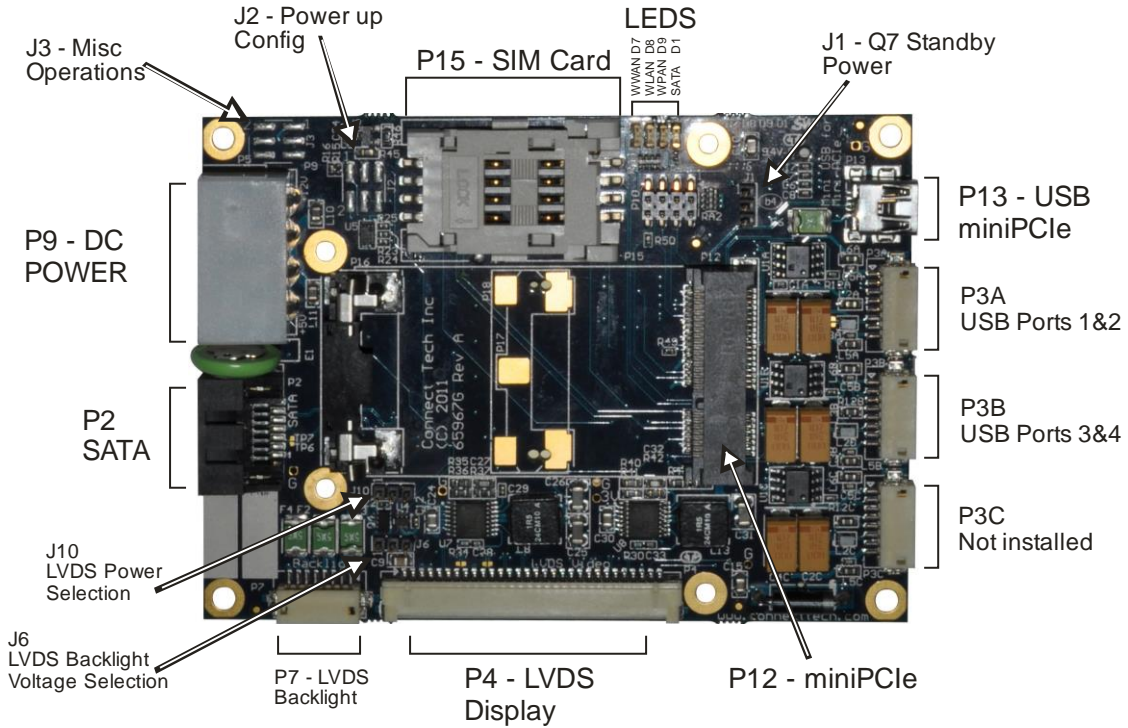

QCG0011

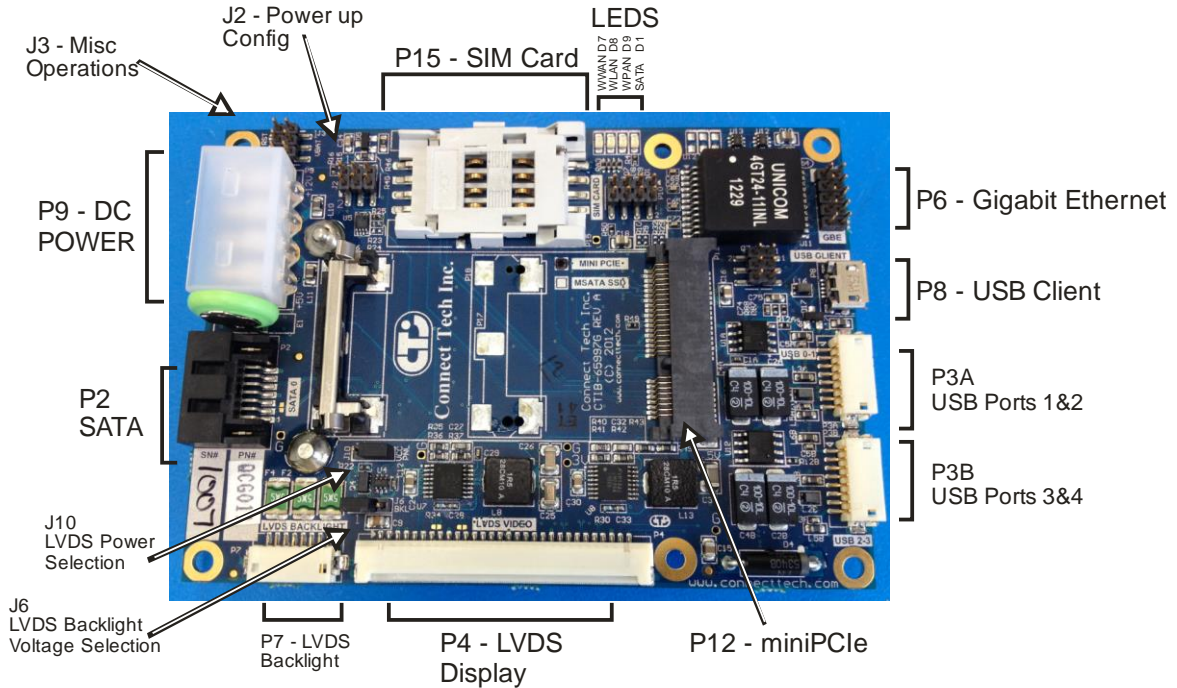

QCG0015

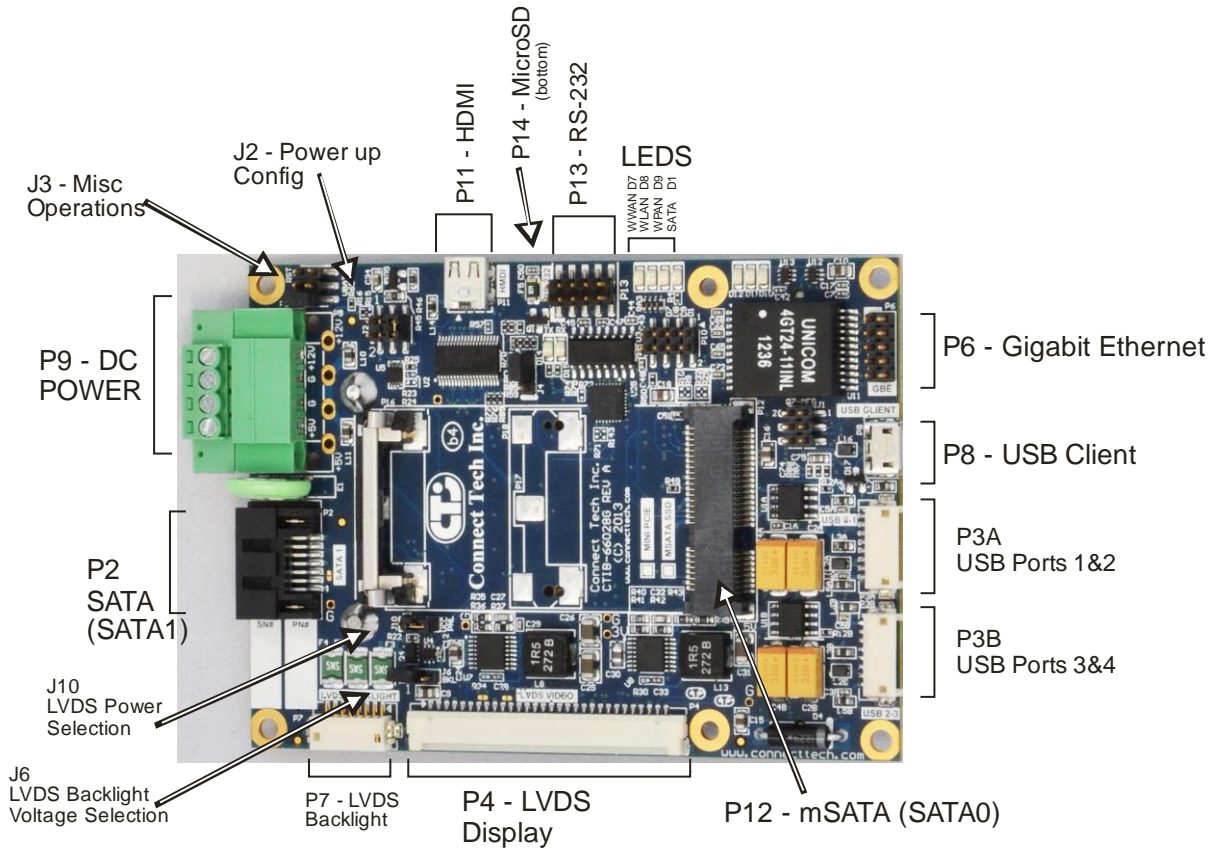

Lite Connector and Jumper Summary

Connector Summary

QCG005	QCG011	QCG015	Connection
P1	P1		Q7
P2	P2	mSATA (P12)	SATA 0
-	-	P2	SATA 1
P3A	P3A	P3A	USB Ports 1 and 2
P3B	P3B	P3B	USB Ports 3 and 4
P4	P4	P4	LVDS Display
P7	P7	P7	LVDS Backlight Power
P9	P9	-	Molex 4 position DC Power
-	-	P5	Screw Term DC Power
P12	P12	-	miniPCle
P15	P15	-	SIMCard
-	-	P11	HDMI
-	P6	P6	GB Ethernet
-	P8	P8	USB Client Port
-	-	P13	RS-232
-	-	P14	Micro SD Card

Jumper Summary

Jumper	Function
J6	LVDS Backlight voltage selection
J10	LVDS Power selection
J2	Power-UP Configuration
J3	Misc. Operations

Lite Qseven Carrier Board Connector Locations

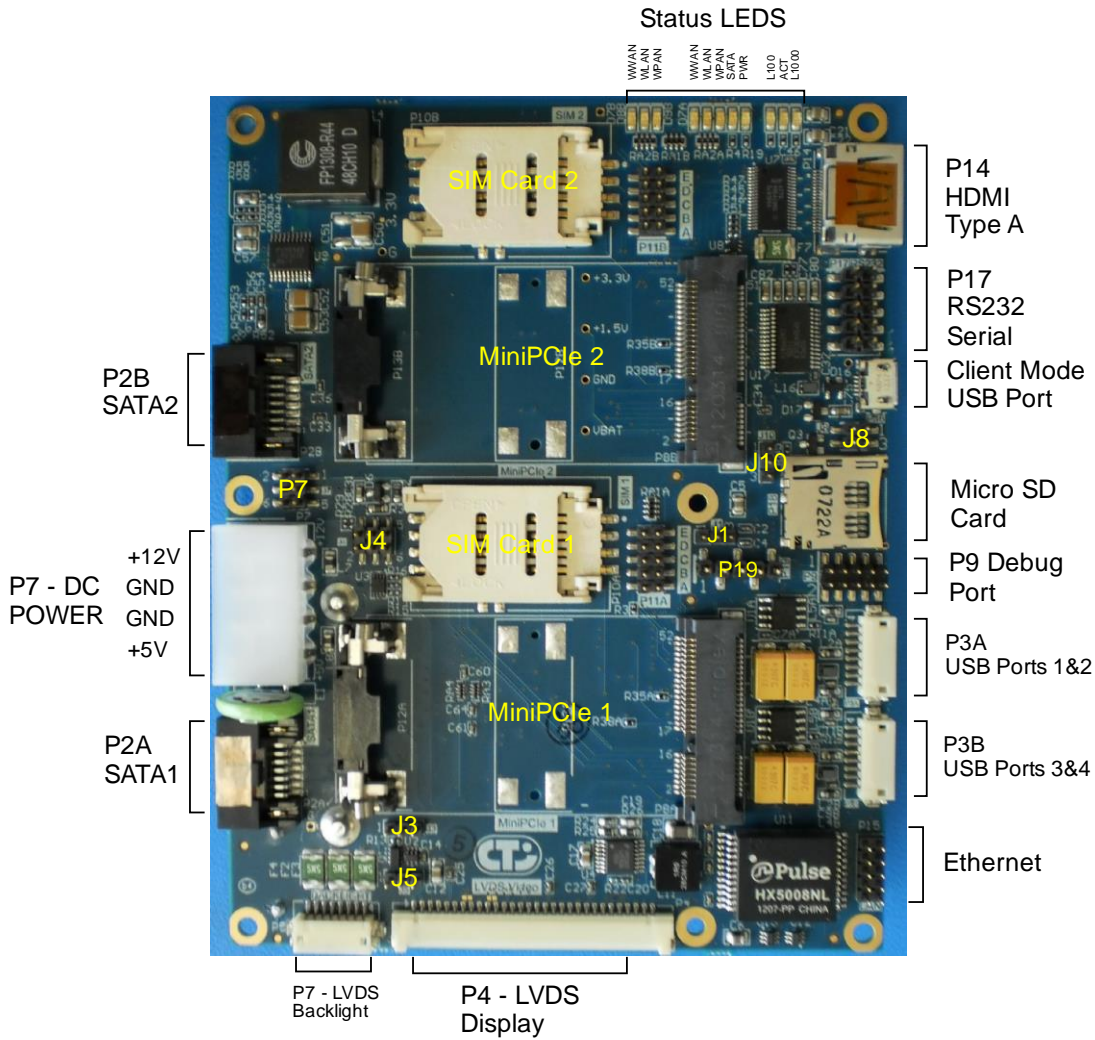

Lite Connector and Jumper Summary

Connector Summary

Location	Connection
P1	Q7
P2A	SATA 1
P2B	SATA 2
P3A	USB Ports 1 and 2
P3B	USB Ports 3 and 4
P4	LVDS Display
P5	LVDS Backlight Power
P6	Molex 4 position DC Power
P7	Optional Screw Term DC Power
P8A	miniPCle 1
P8B	miniPCle 2
P9	JTAG/RS232 Debug
P10A	SIMCard 1
P10B	SIMCard 2
P11A	LED header for miniPCle 1 + SATA
P11B	LED header for miniPCle 2 + Power
P14	HDMI
P15	GB Ethernet
P16	USB Client Port
P17	RS232
P18	Micro SD Card
P19	I2C Battery Interface

Jumper Summary

Jumper	Function
J1	Qseven +5V Standby power
J3	LVDS Power selection
J7	Miscellaneous operations
J5	LVDS Backlight voltage selection
J4	Power up configuration
J8	USB Client/Host and RS232 Mux

Ultra-Lite Carrier Connector Descriptions

Qseven Module Interface

Description

The processor and chipset are implemented on the Qseven CPU module, which connects to the Qseven carrier via a MXM connector. Many of the existing Qseven modules use the Intel® Atom™ mobile architecture, Z series processor SCH US15W chipset. The Qseven carrier implements a subset of the Qseven features, as described in the introduction.

For a list of Qseven module vendors, visit <http://www.qseven-standard.org/>

Connector

Function	Qseven interface
Location	P1
Type	MXM Foxconn AS0B326-S78N-7F (or equivalent)
Pinout	Refer to Qseven specification

Video

The availability of the graphics interfaces depends on the Qseven module selected.

US15W: The US15W chipset provides GMA 500 graphics sub-system and provides two display interfaces: SDVO (serial digital video output) and LVDS (low voltage differential signalling). The resolution generated by the GMA 500 is limited 1280x1024.

ARM: Many of the ARM based Qseven modules support LVDS and HDMI interfaces.

The configuration of either interface as the primary or secondary display depends on the Qseven module's BIOS capabilities and settings. Refer to the Qseven module's documentation for more details.

HDMI

A micro HDMI connector is provided on the QCG015 carrier.

Function	HDMI	
Location	P14	
Type	Micro HDMI Type D	

LVDS

LVDS Video is provided on all of the *Ultra Lite* Qseven Carrier Boards.

Description

The Qseven carrier provides dual 18 or 24 bit LVDS display channels via P4, which are connected directly from the Qseven module. LVDS panel supply power is selected with jumper J104 and backlight power is selected with jumper J6. Both are current limited to 500 mA.

US15W: The US15W provides only a single 18 or 24 bit display channel. Each LVDS data pair carries two bits, each channel has four data pairs.

LVDS Video Header

Function	LVDS Graphics		
Location	P4		
Type	Hirose DF14-30P-1.25H connector		
Pinout	Pin	Signal	Description
		1	VCC_PNL
	2	VCC_PNL	Panel Power
	3	GND	Digital ground
	4	GND	Digital ground
	5	LVDS_A3_N	Channel A Data
	6	LVDS_A3_P	Channel A Data
	7	LVDS_CLK_N	Channel A Clock
	8	LVDS_ACLK_P	Channel A Clock
	9	GND	Digital ground
	10	LVDS_A2_N	Channel A Data
	11	LVDS_A2_P	Channel A Data
	12	LVDS_A1_N	Channel A Data
	13	LVDS_A1_P	Channel A Data
	14	LVDS_A0_N	Channel A Data
	15	LVDS_A0_P	Channel A Data
	16	GND	Digital ground
	17	LVDS_B3_N	Channel B Data
	18	LVDS_B3_P	Channel B Data
	19	LVDS_BCLK_N	Channel B Clock
	20	LVDS_BCLK_P	Channel B Clock
	21	GND	Digital ground
	22	LVDS_B2_N	Channel B Data
	23	LVDS_B2_P	Channel B Data
	24	LVDS_B1_N	Channel B Data
	25	LVDS_B1_P	Channel B Data
	26	LVDS_B0_N	Channel B Data
	27	LVDS_B0_P	Channel B Data
	28	GND	Digital ground
	29	LVDS_DID_CLK	Display ID Clock (3.3V)
	30	LVDS_DID_DATA	Display ID Data (3.3V)



LVDS Backlight

LVDS Backlight connector

Function	LVDS backlight power		
Location	P7		
Type	Hirose DF13-8P-1.25H connector		
Pinout	Pin	Signal	Description
	1	+12V	+12 V DC, max. 1A
	2	+12V	+12 V DC, max. 1A
	3	+5V	+5 V DC, max. 1A
	4	+5V	+5 V DC, max. 1A
	5	LVDS_BLEN	Backlight enable, level selected with J4
	6	VCC_BKL	Back light power, selected with J6
	7	GND	Digital ground
8	GND	Digital ground	



LVDS Backlight Power Jumper

Function	LVDS backlight power select Selects either +12V or +5V. Refer to the display panel's documentation for proper configuration.								
Location	J6								
Type	1x3 0.100" jumper block								
Pinout	<table border="1"> <thead> <tr> <th>Position</th> <th>Description</th> </tr> </thead> <tbody> <tr> <td>1-2</td> <td>+5V</td> </tr> <tr> <td>2-3</td> <td>+12V</td> </tr> <tr> <td>off</td> <td>floating</td> </tr> </tbody> </table>	Position	Description	1-2	+5V	2-3	+12V	off	floating
	Position	Description							
	1-2	+5V							
	2-3	+12V							
off	floating								
Default	+12V								



Power for LVDS Panel Circuits

Function	LVDS panel power select Selects either +3.3V or +5V. Refer to the display documentation for proper configuration.								
Location	J10								
Type	1x3 0.100" jumper block								
Pinout	<table border="1"> <thead> <tr> <th>Position</th> <th>Description</th> </tr> </thead> <tbody> <tr> <td>1-2</td> <td>+5V</td> </tr> <tr> <td>2-3</td> <td>+3.3V</td> </tr> <tr> <td>off</td> <td>floating</td> </tr> </tbody> </table>	Position	Description	1-2	+5V	2-3	+3.3V	off	floating
	Position	Description							
	1-2	+5V							
	2-3	+3.3V							
off	floating								
Default	+3.3V								

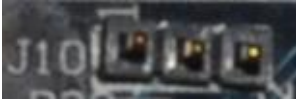

LVDS backlight enable polarity

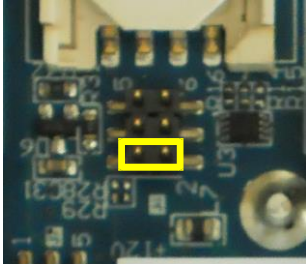
Function	LVDS backlight enable polarity Selects either positive or negative. Refer to the inverter power supply documentation for proper configuration.								
Location	J5								
Type	1x2 2mm jumper block								
Pinout	<table border="1"> <thead> <tr> <th>Position 1-2</th> <th>Description</th> </tr> </thead> <tbody> <tr> <td>Off</td> <td>Positive polarity</td> </tr> <tr> <td>On</td> <td>Negative polarity</td> </tr> </tbody> </table>			Position 1-2	Description	Off	Positive polarity	On	Negative polarity
Position 1-2	Description								
Off	Positive polarity								
On	Negative polarity								
Default	Positive polarity								

USB Operations

User USB Ports

The UltraLite carriers implement 4 of the available USB 2.0 connections via two connectors. Over current protection and power supply filtering is provided. Assume USB Port numbering starts at USB Port 0.

Connector

Function	USB 2.0 x2		
Locations	P3A, P3B		
Type	Hirose DF13-8P		
Pinout	Pin	Signal	Description
	1	VCC_USB_0	Port 0 Filtered +5V
	2	USB_0_N	Port 0 Data
	3	USB_0_P	Port 0 Data
	4	USB_GND_0	Port 0 Filtered Digital Ground
	5	USB_GND_1	Port 1 Filtered Digital Ground
	6	USB_1_N	Port 1 Data
	7	USB_1_P	Port 1 Data
	8	VCC_USB_1	Port 1 Filtered +5V

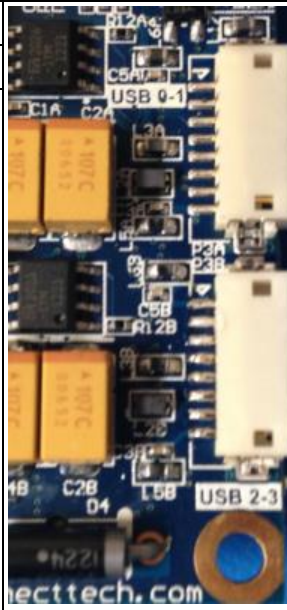

USB Ports on MiniPCIe connectors

On the QCG005 the USB from Mini PCIe is brought out to a Mini USB connector.

On the QCG011 Host USB Port 5 is wired to the MiniPCIe connector.

Note: Assume USB Port numbering starts at 0.

RS232 Serial

Description

The QCG015 UltraLite carrier provides an RS-232 serial port on P13. The serial port is facilitated with a FTDI (FT232RQ) USB to serial IC.

Connector & Jumper

Function	RS232 Serial Port	
Locations	P13	
Type	2x5 2mm vertical header	
Pinout	P17	
	Pin	RS232 Signal
	1	NC
	2	RXD
	3	TXD
	4	NC
	5	GND
	6	NC
	7	RTS
	8	CTS
	9	NC
10	NC	

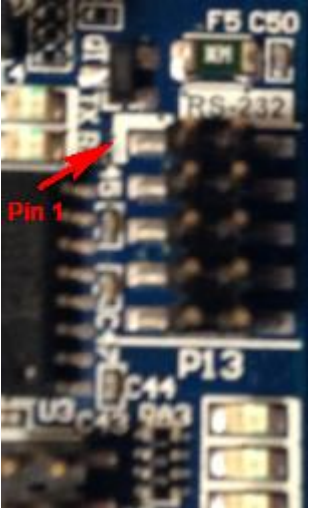

Note 1: A standard 9D RS232 pinout can be achieved using a Connect Tech CBG127 cable.

Note 2: Your operating system will require driver support for this USB UART. Some Operating System come equipment with built in support for this part, others you will have to install the appropriate drivers.

Connect Tech **does not provide** driver support for this part. You can download driver support from the FTDI website at www.ftdichip.com. The part number of the IC is the FT232RQ



SATA

Description

The Qseven carrier provides 1 SATA host connection. On the **QCG005** and **QCG011** carriers this is connected to SATA0, on the **QCG015** it is connected to SATA1

US15W: Some Qseven modules based on the US15W, convert the US15W's IDE interface to one SATA connection (as IDE master) and one built-in NAND based flash drive (as IDE slave). In these configurations only SATA0 is brought out to the carrier. Consult the Qseven module's documentation for more information.

Connector & LEDs

Function	SATA host	QCG005/QCG011	QCG015																
Locations	P2																		
Type	Industry standard right angle SATA host connector Molex 0470804005 (or equivalent)																		
Pinout	<table border="1"> <thead> <tr> <th>Pin</th> <th>Signal</th> </tr> </thead> <tbody> <tr> <td>1</td> <td>GND</td> </tr> <tr> <td>2</td> <td>SATA_TX_P</td> </tr> <tr> <td>3</td> <td>SATA_TX_N</td> </tr> <tr> <td>4</td> <td>GND</td> </tr> <tr> <td>5</td> <td>SATA_RX_N</td> </tr> <tr> <td>6</td> <td>SATA_RX_P</td> </tr> <tr> <td>7</td> <td>GND</td> </tr> </tbody> </table>	Pin	Signal	1	GND	2	SATA_TX_P	3	SATA_TX_N	4	GND	5	SATA_RX_N	6	SATA_RX_P	7	GND		
	Pin	Signal																	
	1	GND																	
	2	SATA_TX_P																	
	3	SATA_TX_N																	
	4	GND																	
	5	SATA_RX_N																	
	6	SATA_RX_P																	
7	GND																		

Function	SATA Status LEDs	Ultra Lite
Location	D1	

miniPCIe

The QCG005 and QCG011 Qseven carriers have 1 miniPCIe connectors.

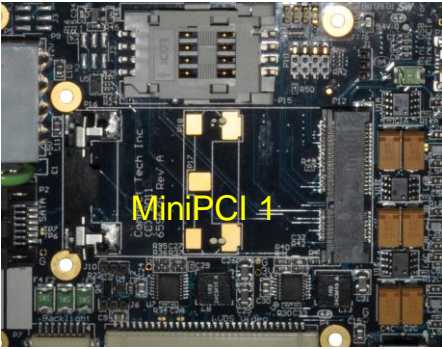
Function	miniPCIe	
Locations	Ultra Lite: P12	
Type	Molex miniPCIe	

miniPCIe SIM Card

The QCG005 and QCG011 Qseven carriers also have 1 miniPCIe SIM Card connector.

Function	SIM Card																			
Locations	P15																			
Type	FCI Hinged, PN: 7112S0825X01LF																			
Pinout	<table border="1"> <thead> <tr> <th>Pin</th> <th>Signal</th> </tr> </thead> <tbody> <tr> <td>1</td> <td>3.3V</td> </tr> <tr> <td>2</td> <td>Reset</td> </tr> <tr> <td>3</td> <td>CLK</td> </tr> <tr> <td>4</td> <td>C4</td> </tr> <tr> <td>5</td> <td>GND</td> </tr> <tr> <td>6</td> <td>VPP</td> </tr> <tr> <td>7</td> <td>DATA</td> </tr> <tr> <td>8</td> <td>C8</td> </tr> </tbody> </table>	Pin	Signal	1	3.3V	2	Reset	3	CLK	4	C4	5	GND	6	VPP	7	DATA	8	C8	
Pin	Signal																			
1	3.3V																			
2	Reset																			
3	CLK																			
4	C4																			
5	GND																			
6	VPP																			
7	DATA																			
8	C8																			

miniPCIe WiFi Status LEDs

The QCG005 and QCG011 Qseven carriers have a set of status LEDs.

Function	Status LEDs	
Locations	Ultra Lite: D7, D8, D9	
	LED	Function
	D7	WWAN
	D8	WLAN
	D9	WPAN

miniPCIe WiFi Jumpers

Function	W_DISABLE	
Locations	P10D	
	Jumper	Function
	IN	Radio Disabled
	OUT	Radio Enabled

Off board status LEDs

The QCG005 and QCG011 Qseven carriers feature a 2mm header which can be used to power off board LEDs.

Ultra Lite Version

Function	Off Board LEDs	
Locations	P10	
	Odd=Anode +V, Even = Cathode	
	Header Pins	Function
	P10-A	WWAN#
	P10-B	WLAN#
P10-C	WPAN#	

Note: Odd pins are connected to 3.3V or 5V with a 470ohm resistor

Micro SD Card

Description

A standard MicroSD card slot is provided on the **QCG015** UltraLite carrier.

Function	Micro SD Card
Locations	P14
Type	Micro SD Card slot
Pinout	

Power

Description

The Ultra Lite Qseven carriers are designed to be powered from a +5V and +12V power supply. The **QCG011** and **QCG011** carrier boards feature a standard Molex HDD power style connector; the **QCG015** features a screw terminal style connector. Both connector styles are available for all carriers, for more information on modifying the power input connector to suit your requirements please [contact sales](#). A Panasonic BR1225A/FA Lithium battery provides the VBAT for the Qseven module.

The Qseven carrier generates 3.3V and 1.5V on board for the miniPCIe connectors and other circuits.

+5V only operation is possible if +12V is not required for the LVDS display backlight.

Power Connectors

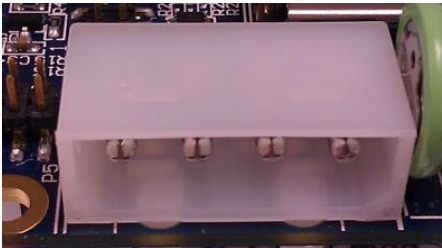
Function	Molex HDD input power(QCG005/QCG011)			QCG005 / QCG011	
Location	P9			 <p>Mating connector Molex: 0015244048 or equivalent</p>	
Type	Molex: 15244441, R/A PCB Connector				
Pinout	Pin	Signal	Description		
	1	+5V	Main Power		
	2	GND	Main Return		
	3	GND	Main Return		
4	+12V	Used for LVDS backlights that require 12VDC			

Function	Screw Terminal Input Power			QCG015	
Location	P5			 <p>Mating connector FCI 20020000-C041B01LF or equivalent</p>	
Type	FCI 20020111-C041A01LF or equivalent				
Pinout	Pin	Signal	Description		
	1	+5V	Main Power		
	2	GND	Main Return		
	3	GND	Main Return		
4	+12V	Used for LVDS backlights that require 12VDC			

+5VSB Jumper (QCG005 Only, QCG011/QCG015 permanently connect +5V SB to +5V)

Function	+5V SB									
Location	J1									
Type	1x3 2 mm									
Pinout	<table border="1"> <thead> <tr> <th>Position</th> <th>Description</th> </tr> </thead> <tbody> <tr> <td>1-2</td> <td>+5V SB powered with 5V</td> </tr> <tr> <td>3-4</td> <td>+5V SB floating. Pins 2-3 have no function</td> </tr> <tr> <td>Off</td> <td>Floating</td> </tr> </tbody> </table>	Position		Description	1-2	+5V SB powered with 5V	3-4	+5V SB floating. Pins 2-3 have no function	Off	Floating
Position	Description									
1-2	+5V SB powered with 5V									
3-4	+5V SB floating. Pins 2-3 have no function									
Off	Floating									

Power Good Jumper

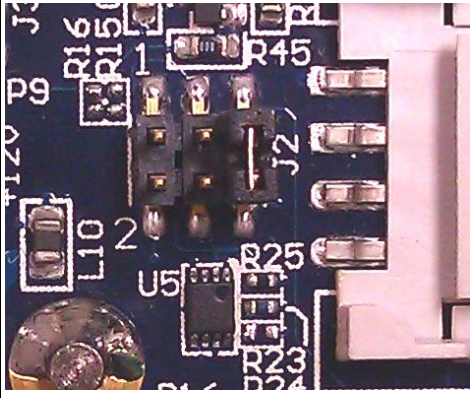
Function	Power Up Control									
Location	J2									
Type	2x3 2 mm									
Pinout	<table border="1"> <thead> <tr> <th>Position</th> <th>Description</th> </tr> </thead> <tbody> <tr> <td>1-2</td> <td>See LVDS backlight</td> </tr> <tr> <td>3-4</td> <td>PWGRIN 10k pullup to 5.0V</td> </tr> <tr> <td>5-6</td> <td>PWGRIN to Q7 module*</td> </tr> </tbody> </table>	Position		Description	1-2	See LVDS backlight	3-4	PWGRIN 10k pullup to 5.0V	5-6	PWGRIN to Q7 module*
Position	Description									
1-2	See LVDS backlight									
3-4	PWGRIN 10k pullup to 5.0V									
5-6	PWGRIN to Q7 module*									

* The Power Good signal is delayed 200mS after the +5V, +3.3V and +1.5V rails are at their stable nominal values. Jumper 5-6 installed is recommended.

Module Current Requirements

Voltage	Current - Ultra Lite	Current - Lite
+5V	Up to 5A	Up to 6.8A
+5V Fuse	5A	7A
+12V	200mA	200mA

Current Consumption information

The majority of the current consumption is from the Qseven and/or the miniPCIe modules.

Module	Current
Qseven Module V1.2	900mA to 1500mA max from 5V rail
MiniPCIe	2750mA max @3.3V / 2020mA from 5V rail

J3 Miscellaneous Functions

Function	Miscellaneous Functions	
Location	J3	
Type	2x3 2 mm	
Pinout	Position	Description
	1-2	Momentary in will generate a reset pulse via PWGRIN signal on Q7 Module. PWGRIN will be pulsed.
	3-4	Connection for external battery
	5-6	QCG015 only: Passive level translation for the HDMI video output. It is recommended that this jumper be left installed.

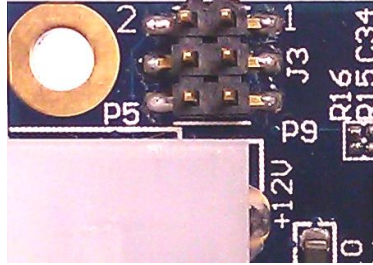

UltraLite Carrier Hardware Installation

1. Ensure all external system power supplies are off.
2. Install the Qseven module into P1. Be sure to follow the manufacturer's direction for proper heatsink/heatspreader installation and any other cooling instructions from the manufacturer.
3. Connect Tech Qseven carriers are equipment with two ECM00870-L standoffs, height 5mm, thread M2.5 for the purpose of securing the Qseven module and head spreader to the Qseven carrier.
4. Verify all jumper settings from the relevant sections, paying special attention the power selection jumpers. Some typical settings are outlined below.

Jumper UltraLite	Function	Selection	Position
J1	Qseven Standby Power (QCG005 only)	+5VSB	1-2
J2	Power Up Control	Power Good Delay	4-6
J2	LVDS backlight enable polarity	positive	1-2 Off
J6	LVDS Backlight Power	+12V	2-3
J10	LVDS panel power	+3.3V	2-3

5. Install the necessary cables for the application. At a minimum, this would include:
 - a) Power cable
 - b) Video display cable LVDS and/or HDMI.
 - c) Keyboard and mouse via USB

For the relevant cables, see the Cables & Interconnect section of this manual

6. Connect the appropriate I/O peripherals to the interface cables: keyboard, mouse, LVDS Display, SATA Disk, USB boot disk, etc.
7. Connect the power cable to power supply
8. Switch on the power supply. DO NOT power up your Qseven system by plugging in live power.

Lite Carrier Connector Descriptions

Qseven Module Interface

Description

The processor and chipset are implemented on the Qseven CPU module, which connects to the Qseven carrier via a MXM connector. Many of the existing Qseven modules use the Intel® Atom™ mobile architecture, Z series processor SCH US15W chipset. The Qseven carrier implements a subset of the Qseven features, as described in the introduction.

For a list of Qseven module vendors, visit <http://www.qseven-standard.org/>

Connector

Function	Qseven interface
Location	P1
Type	MXM Foxconn AS0B326-S78N-7F (or equivalent)
Pinout	Refer to Qseven specification

Video

The availability of the graphics interfaces depends on the Qseven module selected.

US15W: The US15W chipset provides GMA 500 graphics sub-system and provides two display interfaces: SDVO (serial digital video output) and LVDS (low voltage differential signalling). The resolution generated by the GMA 500 is limited 1280x1024.

The configuration of either interface as the primary or secondary display depends on the Qseven module's BIOS capabilities and settings. Refer to the Qseven module's documentation for more details.

HDMI

Function	HDMI	
Location	P14	
Type	Standard HDMI Type A	

LVDS

Description

The Qseven carrier provides dual 18 or 24 bit LVDS display channels via P4, which are connected directly from the Qseven module. LVDS panel supply power is selected with jumper J104 and backlight power is selected with jumper J6. Both are current limited to 500 mA.

US15W: The US15W provides only a single 18 or 24 bit display channel. Each LVDS data pair carries two bits, each channel has four data pairs.

LVDS Video Header

Function	LVDS Graphics		
Location	P4		
Type	Hirose DF14-30P-1.25H connector		
Pinout	Pin	Signal	Description
	1	VCC_PNL	Panel Power
	2	VCC_PNL	Panel Power
	3	GND	Digital ground
	4	GND	Digital ground
	5	LVDS_A3_N	Channel A Data
	6	LVDS_A3_P	Channel A Data
	7	LVDS_CLK_N	Channel A Clock
	8	LVDS_ACLK_P	Channel A Clock
	9	GND	Digital ground
	10	LVDS_A2_N	Channel A Data
	11	LVDS_A2_P	Channel A Data
	12	LVDS_A1_N	Channel A Data
	13	LVDS_A1_P	Channel A Data
	14	LVDS_A0_N	Channel A Data
	15	LVDS_A0_P	Channel A Data
	16	GND	Digital ground
	17	LVDS_B3_N	Channel B Data
	18	LVDS_B3_P	Channel B Data
	19	LVDS_BCLK_N	Channel B Clock
	20	LVDS_BCLK_P	Channel B Clock
	21	GND	Digital ground
	22	LVDS_B2_N	Channel B Data
	23	LVDS_B2_P	Channel B Data
	24	LVDS_B1_N	Channel B Data
	25	LVDS_B1_P	Channel B Data
	26	LVDS_B0_N	Channel B Data
	27	LVDS_B0_P	Channel B Data
	28	GND	Digital ground
	29	LVDS_DID_CLK	Display ID Clock (3.3V)
30	LVDS_DID_DATA	Display ID Data (3.3V)	



LVDS Backlight

LVDS Backlight connector

Function	LVDS backlight power		
Location	P5		
Type	Hirose DF13-8P-1.25H connector		
Pinout	Pin	Signal	Description
	1	+12V	+12 V DC, max. 1A
	2	+12V	+12 V DC, max. 1A
	3	+5V	+5 V DC, max. 1A
	4	+5V	+5 V DC, max. 1A
	5	LVDS_BLEN	Backlight enable, level selected with J4
	6	VCC_BKL	Back light power, selected with J6
	7	GND	Digital ground
	8	GND	Digital ground



LVDS Backlight Power Jumper

Function	LVDS backlight power select Selects either +12V or +5V. Refer to the display panel's documentation for proper configuration.								
Location	J5								
Type	1x3 0.100" jumper block								
Pinout	<table border="1"> <thead> <tr> <th>Position</th> <th>Description</th> </tr> </thead> <tbody> <tr> <td>1-2</td> <td>+5V</td> </tr> <tr> <td>2-3</td> <td>+12V</td> </tr> <tr> <td>off</td> <td>floating</td> </tr> </tbody> </table>	Position	Description	1-2	+5V	2-3	+12V	off	floating
	Position	Description							
	1-2	+5V							
	2-3	+12V							
off	floating								
Default	+12V								



Power for LVDS Panel Circuits

Function	LVDS panel power select Selects either +3.3V or +5V. Refer to the display documentation for proper configuration.								
Location	Ultralite J10, Lite J3								
Type	1x3 0.100" jumper block								
Pinout	<table border="1"> <thead> <tr> <th>Position</th> <th>Description</th> </tr> </thead> <tbody> <tr> <td>1-2</td> <td>+5V</td> </tr> <tr> <td>2-3</td> <td>+3.3V</td> </tr> <tr> <td>off</td> <td>floating</td> </tr> </tbody> </table>	Position	Description	1-2	+5V	2-3	+3.3V	off	floating
	Position	Description							
	1-2	+5V							
	2-3	+3.3V							
off	floating								
Default	+3.3V								

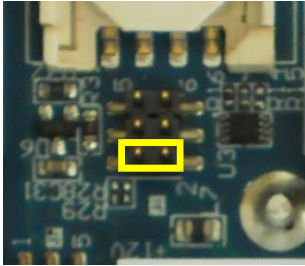

LVDS backlight enable polarity

Function	LVDS backlight enable polarity Selects either positive or negative. Refer to the inverter power supply documentation for proper configuration.								
Location	J4								
Type	1x2 2mm jumper block								
Pinout	<table border="1"> <thead> <tr> <th>Position 1-2</th> <th>Description</th> </tr> </thead> <tbody> <tr> <td>Off</td> <td>Positive polarity</td> </tr> <tr> <td>On</td> <td>Negative polarity</td> </tr> </tbody> </table>	Position 1-2		Description	Off	Positive polarity	On	Negative polarity	
Position 1-2	Description								
Off	Positive polarity								
On	Negative polarity								
Default	Positive polarity								

USB Operations

User USB Ports

The Lite Qseven carrier implements 4 of the available USB 2.0 connections via two connectors. Over current protection and power supply filtering is provided. Assume USB Port numbering starts at USB Port 0.

Connector

Function	USB 2.0 x2																														
Locations	P3A, P3B																														
Type	Hirose DF13-8P																														
Pinout	<table border="1"> <thead> <tr> <th>Pin</th> <th>Signal</th> <th>Description</th> </tr> </thead> <tbody> <tr> <td>1</td> <td>VCC_USB_0</td> <td>Port 0 Filtered +5V</td> </tr> <tr> <td>2</td> <td>USB_0_N</td> <td>Port 0 Data</td> </tr> <tr> <td>3</td> <td>USB_0_P</td> <td>Port 0 Data</td> </tr> <tr> <td>4</td> <td>USB_GND_0</td> <td>Port 0 Filtered Digital Ground</td> </tr> <tr> <td>5</td> <td>USB_GND_1</td> <td>Port 1 Filtered Digital Ground</td> </tr> <tr> <td>6</td> <td>USB_1_N</td> <td>Port 1 Data</td> </tr> <tr> <td>7</td> <td>USB_1_P</td> <td>Port 1 Data</td> </tr> <tr> <td>8</td> <td>VCC_USB_1</td> <td>Port 1 Filtered +5V</td> </tr> </tbody> </table>	Pin	Signal		Description	1	VCC_USB_0	Port 0 Filtered +5V	2	USB_0_N	Port 0 Data	3	USB_0_P	Port 0 Data	4	USB_GND_0	Port 0 Filtered Digital Ground	5	USB_GND_1	Port 1 Filtered Digital Ground	6	USB_1_N	Port 1 Data	7	USB_1_P	Port 1 Data	8	VCC_USB_1	Port 1 Filtered +5V		
Pin	Signal	Description																													
1	VCC_USB_0	Port 0 Filtered +5V																													
2	USB_0_N	Port 0 Data																													
3	USB_0_P	Port 0 Data																													
4	USB_GND_0	Port 0 Filtered Digital Ground																													
5	USB_GND_1	Port 1 Filtered Digital Ground																													
6	USB_1_N	Port 1 Data																													
7	USB_1_P	Port 1 Data																													
8	VCC_USB_1	Port 1 Filtered +5V																													

Note1: The USB Host Port 1 is multiplexed with the USB Client mode. See **USB Client/Host Mode** for more information.

Note 2: USB Port 3 is multiplexed with the USB UART to provide a RS232 serial port.

USB Client/Host Port Mode

Port 1 of the Qseven Lite carrier can be configured for either Client mode or Host mode:

- Host mode is the typical mode of operation. It is used to connect items like keyboards and USB memory sticks.
- Client mode is used to provide an application specific USB connection to the Qseven CPU.
- Refer to your Qseven module vendor for Client mode software support and operations instructions.

USB Client Host Operation

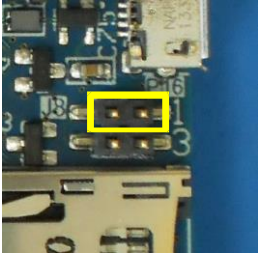
Function	Select USB Client Host Operation							
Location	J8 pins 1-2							
Type	2x2 2mm jumper block							
Pinout	<table border="1"> <thead> <tr> <th>Position 1-2</th> <th>Description</th> </tr> </thead> <tbody> <tr> <td>Off</td> <td>Host Mode</td> </tr> <tr> <td>On</td> <td>Client Mode</td> </tr> </tbody> </table>	Position 1-2		Description	Off	Host Mode	On	Client Mode
Position 1-2	Description							
Off	Host Mode							
On	Client Mode							

USB Ports on MiniPCIe connectors

USB Port 4 and USB Port 5 are wired to the MiniPCIe connectors as follows:

- USB Port 4 = MiniPCIe 1
- USB Port 5 = MiniPCIe 2

Note: Assume USB Port numbering starts at 0.

RS232 Serial

Description

The Lite version of Qseven carrier provides one RS232 serial port on P17. The serial port is facilitated with a FTDI (FT232RQ) USB to serial IC.

The USB to Serial IC is multiplexed with USB Port 3.

Connector & Jumper

Function	RS232 Serial Port																						
Locations	P17 and J8 (3-4)																						
Type	2x5 0.1" vertical header and 2x2 2mm header																						
Pinout	P17																						
	<table border="1"> <thead> <tr> <th>Pin</th> <th>RS232 Signal</th> </tr> </thead> <tbody> <tr><td>1</td><td>DCD</td></tr> <tr><td>2</td><td>DSR</td></tr> <tr><td>3</td><td>RXD</td></tr> <tr><td>4</td><td>RTS</td></tr> <tr><td>5</td><td>TXD</td></tr> <tr><td>6</td><td>CTS</td></tr> <tr><td>7</td><td>DTR</td></tr> <tr><td>8</td><td>RI</td></tr> <tr><td>9</td><td></td></tr> <tr><td>10</td><td>NC</td></tr> </tbody> </table>	Pin	RS232 Signal	1	DCD	2	DSR	3	RXD	4	RTS	5	TXD	6	CTS	7	DTR	8	RI	9		10	NC
Pin	RS232 Signal																						
1	DCD																						
2	DSR																						
3	RXD																						
4	RTS																						
5	TXD																						
6	CTS																						
7	DTR																						
8	RI																						
9																							
10	NC																						
	J8																						
	<table border="1"> <thead> <tr> <th>Jumper</th> <th>USB Mode</th> </tr> </thead> <tbody> <tr><td>In</td><td>USB Host Port</td></tr> <tr><td>Out</td><td>USB to UART</td></tr> </tbody> </table>	Jumper	USB Mode	In	USB Host Port	Out	USB to UART																
Jumper	USB Mode																						
In	USB Host Port																						
Out	USB to UART																						
	<i>Note: Jumper should not be installed with power on.</i>																						

Note 1: A standard 9D RS232 pinout can be achieved using a Connect Tech CAG104 cable.

Note 2: Your operating system will require driver support for this USB UART. Some Operating System come equipment with built in support for this part, others you will have to install the appropriate drivers.

Connect Tech **does not provide** driver support for this part. You can download driver support from the FTDI website at www.ftdichip.com. The part number of the IC is the FT232RQ

Note3: The RS232 transceiver is the Exar SP3243. It is configured to use the “Auto-Online” mode of operation. This means that it will off and not driving signals until any of the inputs (RXD, CTS, RI, DSR or DCD) detect a voltage. This voltage will be provided when you connect the port to your RS232 device.

SATA

Description

The Qseven carrier provides 1 or 2 SATA host connections.

US15W: Some Qseven modules based on the US15W, convert the US15W's IDE interface to one SATA connection (as IDE master) and one built-in NAND based flash drive (as IDE slave). Consult the Qseven module's documentation for more information.

In this case only P10A connector is active.

Connector & LEDs

Function	SATA host																	
Locations	Lite: P2A, P2B																	
Type	Industry standard right angle SATA host connector Molex 0470804005 (or equivalent)																	
Pinout	<table border="1" style="width: 100%; border-collapse: collapse;"> <thead> <tr> <th style="width: 15%;">Pin</th> <th style="width: 85%;">Signal</th> </tr> </thead> <tbody> <tr> <td>1</td> <td>GND</td> </tr> <tr> <td>2</td> <td>SATA_TX_P</td> </tr> <tr> <td>3</td> <td>SATA_TX_N</td> </tr> <tr> <td>4</td> <td>GND</td> </tr> <tr> <td>5</td> <td>SATA_RX_N</td> </tr> <tr> <td>6</td> <td>SATA_RX_P</td> </tr> <tr> <td>7</td> <td>GND</td> </tr> </tbody> </table>			Pin	Signal	1	GND	2	SATA_TX_P	3	SATA_TX_N	4	GND	5	SATA_RX_N	6	SATA_RX_P	7
Pin	Signal																	
1	GND																	
2	SATA_TX_P																	
3	SATA_TX_N																	
4	GND																	
5	SATA_RX_N																	
6	SATA_RX_P																	
7	GND																	

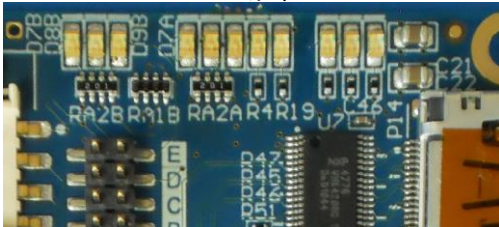
Function	SATA Status LEDs	Lite
Location	D1	

miniPCIe

The Qseven carrier has 2 miniPCIe connectors.

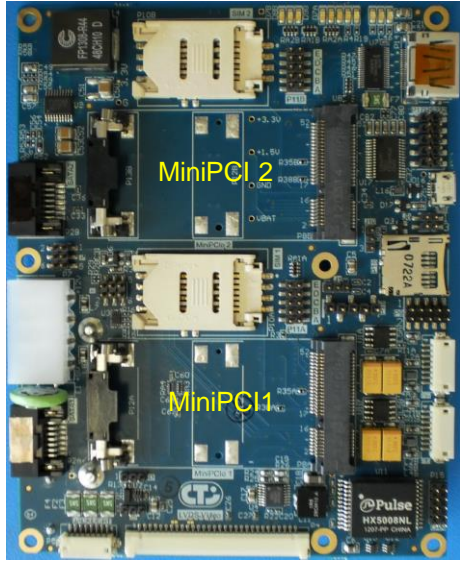
Function	miniPCIe	Lite
Locations	P8A, P8B	
Type	Molex miniPCIe	

miniPCIe SIM Card

The Qseven carrier has 2 miniPCIe SIM Card connectors.

Function	SIM Card																			
Locations	P10A, P10B																			
Type	FCI Hinged, PN: 7112S0825X01LF																			
Pinout	<table border="1"> <thead> <tr> <th>Pin</th> <th>Signal</th> </tr> </thead> <tbody> <tr> <td>1</td> <td>3.3V</td> </tr> <tr> <td>2</td> <td>Reset</td> </tr> <tr> <td>3</td> <td>CLK</td> </tr> <tr> <td>4</td> <td>C4</td> </tr> <tr> <td>5</td> <td>GND</td> </tr> <tr> <td>6</td> <td>VPP</td> </tr> <tr> <td>7</td> <td>DATA</td> </tr> <tr> <td>8</td> <td>C8</td> </tr> </tbody> </table>	Pin	Signal	1	3.3V	2	Reset	3	CLK	4	C4	5	GND	6	VPP	7	DATA	8	C8	
Pin	Signal																			
1	3.3V																			
2	Reset																			
3	CLK																			
4	C4																			
5	GND																			
6	VPP																			
7	DATA																			
8	C8																			

miniPCIe WiFi Status LEDs

The Qseven carrier has 2 sets of status LEDs.

Function	Status LEDs	
Locations	D7A, D8A, D9A, D7B, D8B, D9B	
	LED	Function
	D7A, D7B	WWAN
	D8A, D8B	WLAN
	D9A, D9B	WPAN

Off board status LEDs

The Qseven carrier features 2mm headers which can be used to power off board LEDs.

Function	Off Board LEDs	
Locations	P11A and P11B	
	Odd=Anode +V, Even = Cathode	
	Header Pins	Function
	P11(A/B)-A	SATA Activity / 5V Pwr
	P11(A/B)-B	NC / 3.3V Pwr
	P11(A/B)-C	WWAN#
	P11(A/B)-D	WLAN#
P11(A/B)-E	WPAN#	

Note: Odd pins are connected to 3.3V or 5V with a 470ohm resistor.

Debug JTAG and RS232 on Lite Version

The Lite carrier brings out the Qseven MFG(0..4) pins for JTAG and RS232 debug purposes features on ARM and Tegra based models.

Function	Debug Interface			
Locations	P9			
Type	2x5 2mm Header 1x3 2mm Jumper			
Pinout	2x5 Header			
	Pin	Signal	Pin	Signal
	1	TRST#	2	+3.3V
	3	TMS	4	NC
	5	TDI / RX	6	TX_232
	7	TDO / TX	8	RX_232
	9	TCK	10	GND
	1x3 Jumper			
	Pin	Signal		
	1	RX_Out		
	2	TDI/RX from Q7		
	3	TDI signal to Header		

Circuit Schematic

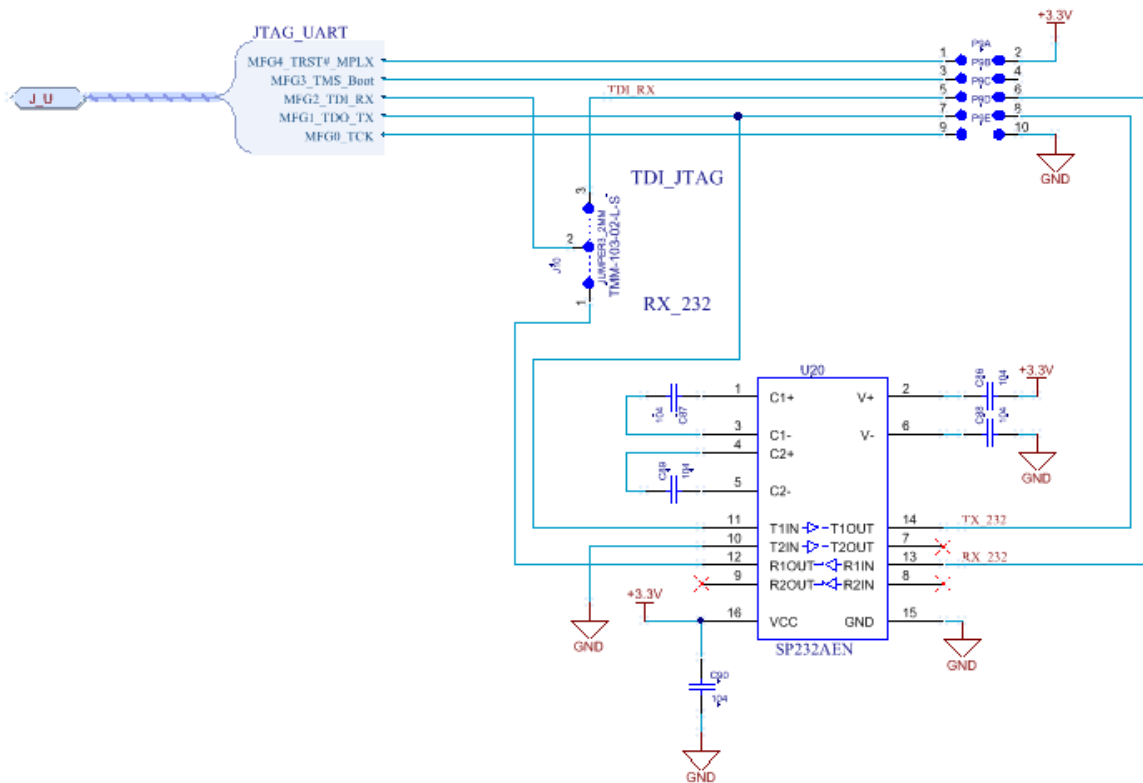

Micro SD Card

Description

Function	Micro SD Card
Locations	P18
Type	Micro SD Card slot
Pinout	

Power

Description

The Lite Qseven carrier is designed to be powered from a +5V and +12V power supply. The carrier board feature a standard Molex HDD power style connector, or optional screw terminal style connectors (contact sales@connecttech.com for more about screw terminal connectors).

A Panasonic BR1225A/FA Lithium battery provides the VBAT for the Qseven module.

The Qseven carrier generates 3.3V and 1.5V on board for the miniPCIe connectors and other circuits.

+5V only operation is possible if +12V is not required for the LVDS display backlight.

Power Connectors

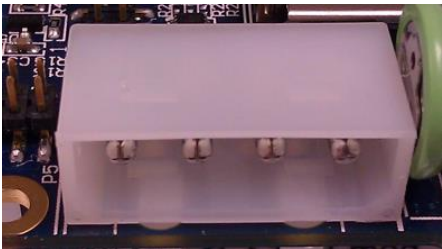
Function	Molex HDD input power			 <p>Mating connector Molex: 0015244048</p>
Location	P6			
Type	Molex: 15244441, R/A PCB Connector			
Pinout	Pin	Signal	Description	
	1	+5V	Main Power	
	2	GND	Main Return	
	3	GND	Main Return	
	4	+12V	Used for LVDS backlights that require 12VDC	

+5VSB Jumper

Function	+5V SB		
Location	J1		
Type	1x3 2 mm		
Pinout	Position	Description	
	1-2	+5V SB powered with 5V	
	3-4	+5V SB floating. Pins 2-3 have no function	
	Off	Floating	

Power Good Jumper

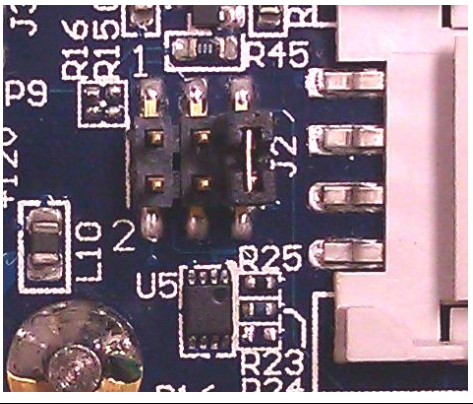
Function	Power Up Control									
Location	J4									
Type	2x3 2 mm									
Pinout	<table border="1"> <thead> <tr> <th>Position</th> <th>Description</th> </tr> </thead> <tbody> <tr> <td>1-2</td> <td>See LVDS backlight</td> </tr> <tr> <td>3-4</td> <td>PWGRIN 10k pullup to 5.0V</td> </tr> <tr> <td>5-6</td> <td>PWGRIN to Q7 module*</td> </tr> </tbody> </table>	Position		Description	1-2	See LVDS backlight	3-4	PWGRIN 10k pullup to 5.0V	5-6	PWGRIN to Q7 module*
Position	Description									
1-2	See LVDS backlight									
3-4	PWGRIN 10k pullup to 5.0V									
5-6	PWGRIN to Q7 module*									

* The Power Good signal is delayed 200mS after the +5V, +3.3V and +1.5V rails are at their stable nominal values. Jumper 5-6 installed is recommended.

Module Current Requirements

Voltage	Current - Ultra Lite	Current - Lite
+5V	Up to 5A	Up to 6.8A
+5V Fuse	5A	7A
+12V	200mA	200mA

Current Consumption information

The majority of the current consumption is from the Qseven and the miniPCIE modules.

Module	Current
Qseven Module V1.2	900mA to 1500mA max from 5V rail
MiniPCIE	2750mA max @3.3V / 2020mA from 5V rail

J3 Miscellaneous Functions

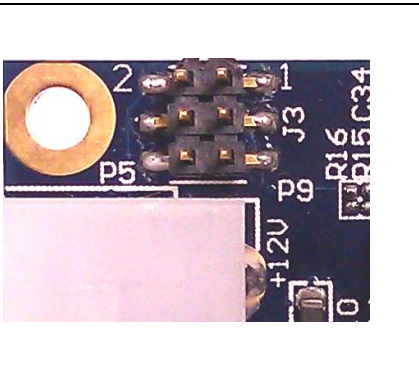
Function	Miscellaneous Functions									
Location	J7									
Type	2x3 2 mm									
Pinout	<table border="1"> <thead> <tr> <th>Position</th> <th>Description</th> </tr> </thead> <tbody> <tr> <td>1-2</td> <td>Momentary in will generate a reset pulse via PWGRIN signal on Q7 Module. PWGRIN will be pulsed.</td> </tr> <tr> <td>3-4</td> <td>Connection for external battery</td> </tr> <tr> <td>5-6</td> <td>Ultralite No function, Lite PWRBTN to Q7 module.</td> </tr> </tbody> </table>	Position		Description	1-2	Momentary in will generate a reset pulse via PWGRIN signal on Q7 Module. PWGRIN will be pulsed.	3-4	Connection for external battery	5-6	Ultralite No function, Lite PWRBTN to Q7 module.
Position	Description									
1-2	Momentary in will generate a reset pulse via PWGRIN signal on Q7 Module. PWGRIN will be pulsed.									
3-4	Connection for external battery									
5-6	Ultralite No function, Lite PWRBTN to Q7 module.									

Lite Carrier Hardware Installation

9. Ensure all external system power supplies are off.
10. Install the Qseven module into P1. Be sure to follow the manufacturer's direction for proper heatsink/heatspreader installation and any other cooling instructions from the manufacturer.
11. Connect Tech Qseven carriers are equipment with two ECM00870-L standoffs, height 5mm, thread M2.5 for the purpose of securing the Qseven module and head spreader to the Qseven carrier.
12. Verify all jumper settings from the relevant sections, paying special attention the power selection jumpers. Some typical settings are outlined below.

Jumper	Function	Selection	Position
J1	Qseven Standby Power	+5VSB	1-2
J7	Power Up Control	Power Good Delay	4-6
J7	LVDS backlight enable polarity	positive	1-2 Off
J5	LVDS Backlight Power	+12V	2-3
J3	LVDS panel power	+3.3V	2-3

13. Install the necessary cables for the application. At a minimum, this would include:
 - d) Power cable
 - e) Video display cable LVDS and/or HDMI.
 - f) Keyboard and mouse via USB

For the relevant cables, see the Cables & Interconnect section of this manual

14. Connect the appropriate I/O peripherals to the interface cables: keyboard, mouse, LVDS Display, SATA Disk, USB boot disk, etc.
15. Connect the power cable to power supply
16. Switch on the power supply. DO NOT power up your Qseven system by plugging in live power.

Software Installation & Configuration

In general, always refer to the Qseven module's manual for proper installation of software drivers and configuration software; as well as for appropriate BIOS settings.

The following sections provides some specific notes and hints for successful module integration

Operating System Notes

Linux

US15W Specific

Graphics: Intel Driver support for the Poulsbo / GMA500 is limited to several distributions (Redhat, Fedora). See IEGD (Intel Embedded Graphics Driver) website for details
<http://edc.intel.com/Software/Downloads/IEGD/#compatibility>

Other distributions, such as Linux, are supported through the open source community.

Windows

US15W Specific

Graphics: In some cases, the secondary LVDS display will appear washed out, to avoid this ensure the correct version of the IEGD is installed.

Cables & Interconnect

The following table summarizes the Qseven carrier's headers and lists the matching cables included with the optional cable kit CKG001.

PCB Connector	Cable Part Number	Drawing Number	Description	PCB End	Interface End
Hirose DF13-8P-1.25H(50)	CBG071	CTIC-00182	USB (dual)	Hirose DF13A-8S-1.25C	USB 2.0 Type A female
Hirose DF14-30P-1.25H(25)	CBG076	CTIC-00196	LVDS un-terminated	Hirose DF14-30S-1.25C	N/A
Hirose DF13-8P-1.25H(50)	CBG078	CTIC-00198	Backlight un-terminated	Hirose DF13A-8S-1.25C	N/A
Molex 470804005	CBG079	CTIC-00199	SATA	SATA	SATA
Samtec TMM-102-02-L-S	CBG080	CTIC-00200	Reset Button	1x2 2mm socket	Momentary Pushbutton
10-pin 2mm Pitch Header	CBG065	CTIC-00181	Gigabit Ethernet Cable	10-pin 2mm Pitch Header	RJ-45
HDMI Type A	NA	NA	Standard HDMI cable, not provided by Connect Tech Inc.	HDMI Type A	HDMI Type A

Other cables:

PCB Connector	Cable Part Number	Drawing Number	Description	PCB End	Interface End
2x5 0,1" header	CAG104	CTIC-00048	10 CCT 0.1" to DB9M	10 CCT 0.1"	DB9 Male

Cable drawings are available upon request. Send an email to: support@connecttech.com.

Dimensions Ultra Lite Qseven Carrier Boards

100mm

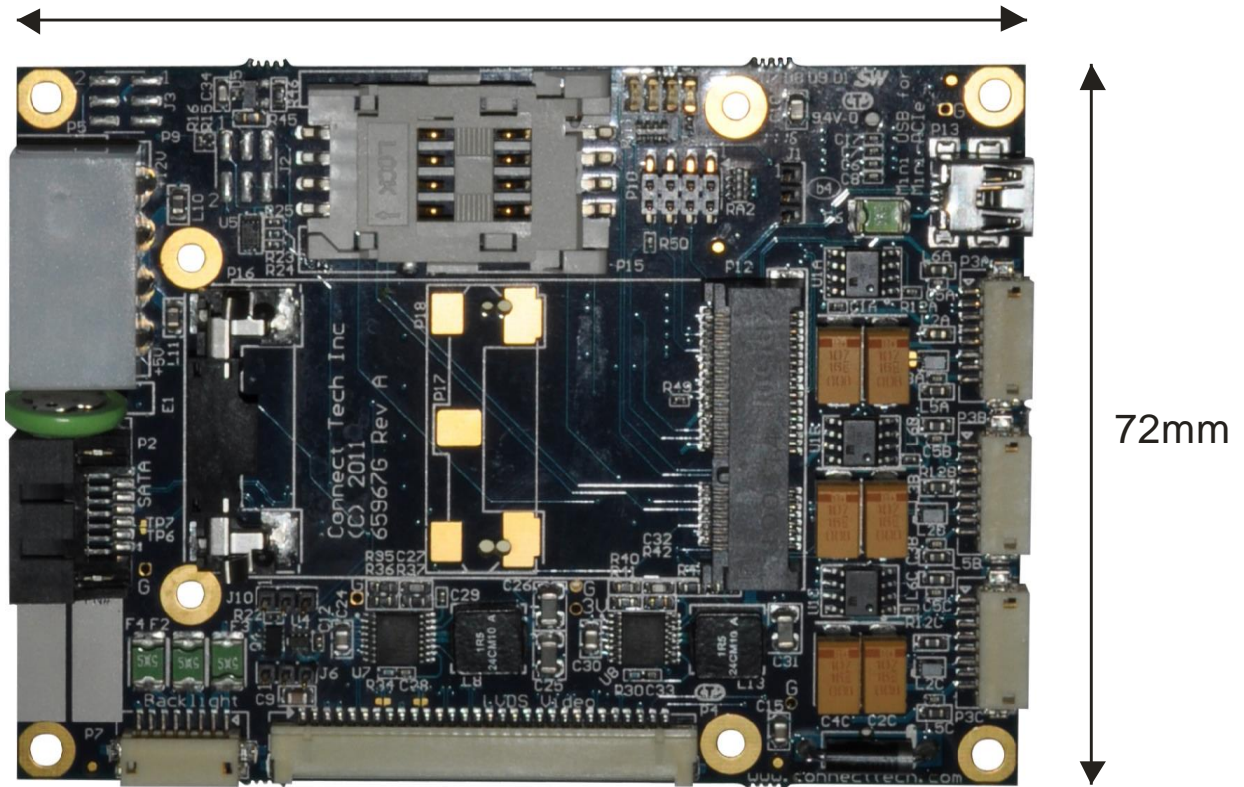

PicoITX Form factor

Dimensions Lite Qseven Carrier Board

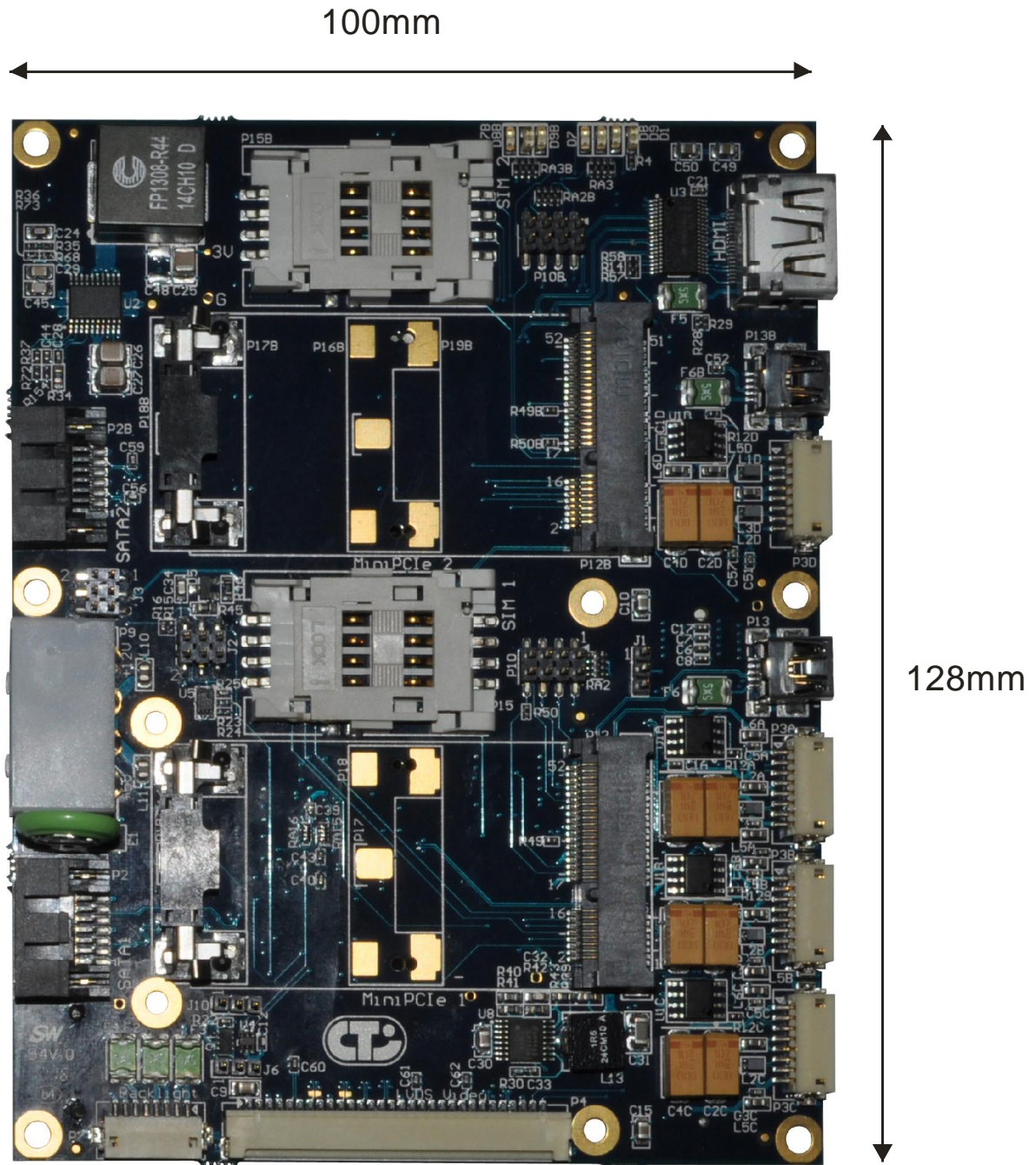

Part Numbers

The following are the base model part numbers for the Ultra Lite and Lite Qseven Carrier Boards:

Part Number	Description	Size
QCG005	Ultra Lite Qseven Carrier Board	PicoITX 100x72mm
QCG006	Lite Qseven Carrier Board	100x128mm
QCG011	Ultra Lite Qseven Carrier Board w/ GBE and USB Client	PicoITX 100x72mm
QCG015	Ultra Lite Qseven Carrier Board w/ HDMI, mSATA, GBE, microSD, RS-232 and USB Client	PicoITX 100x72mm