



This Datasheet for the

[IC697BEM731](#)

Series 90-70 Genius I/O Bus Controller.

<http://www.qualitrol.com/shop/p-14755-ic697bem731.aspx>

Provides the wiring diagrams and installation guidelines for this GE Series 90-30 module.

For further information, please contact Qualitrol Technical Support at

1-800-784-9385

support@qualitrol.com

Bus Expansion Modules

IC697BEM731/734

GFK-0165G
August 1997

Bus Controller Module

Features

- Thirty Drops per channel
- IC66* (IC660 or IC661) I/O Diagnostics
- Redundant blocks, cables and CPUs supported
- Global Communications
- Hand Held Monitor Port
- IC66* LAN Communications
- Soft configuration by CPU
- Operation augmented by IC697 PLC Alarm Processor function

Functions

The IC66* Bus Controller (GBC/NBC) is available as a single channel controller. It occupies a single IC66* PLC slot. The bus controller is configured by the MS-DOS® or Windows® programming software configurator function. IC66* Input/Output blocks are scanned asynchronously by the bus controller and I/O data is transferred to the CPU once per scan over the backplane of the IC697 PLC rack.

The bus controller also supports directed communications initiated by a PLC CPU Communication Service Request. In addition, it may be configured to perform global communications.

Faults reported by the bus controller are managed by the PLC Alarm Processor Function which time stamps and queues faults in a table.

For applications requiring peer to peer information transfer, the Bus Controller can serve as a communications node linking other devices (Bus Controllers, PCIMs, and other IC66* devices) via the IC66* bus. Such a network can provide communications between multiple PLCs and host computers.

These communications include transmitting global data from one CPU to another. The global data area is identified by MS-DOS or Windows configuration. After initialization, the specified data area is transferred between devices automatically and repetitively.

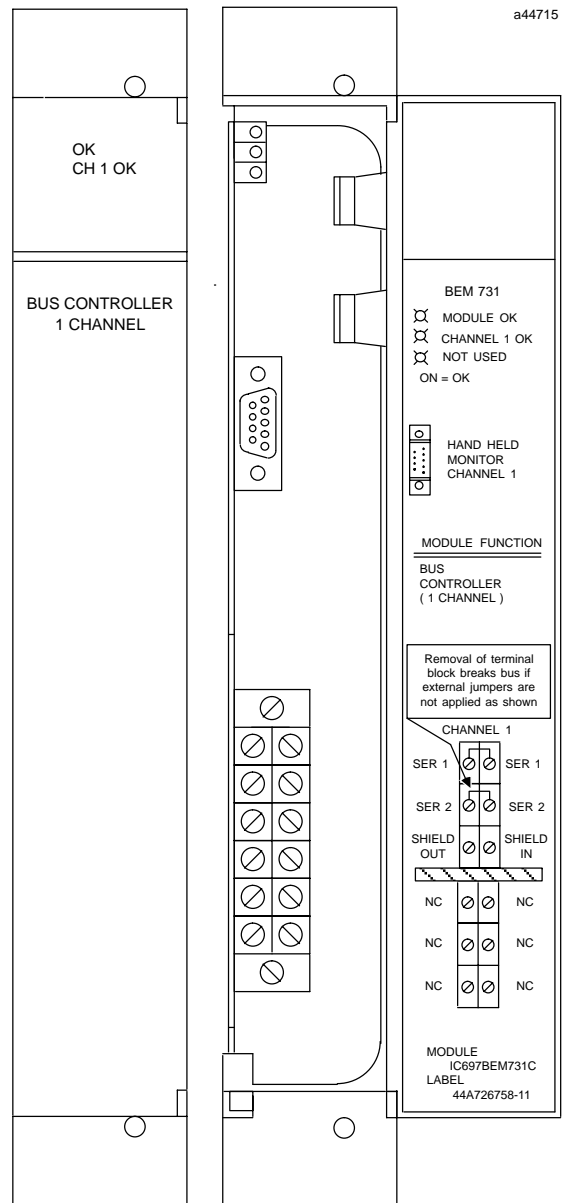

In addition, messages called Datagrams can be transmitted in response to individual commands in the ladder logic. Datagrams can be sent from one device on the network to another, or broadcast to all devices on the bus. IC66* LAN communications are supported throughout the IC69* PLC family.

© MS-DOS and Windows are registered trademarks of Microsoft Corporation.

GFK-0165G
August 1997

Bus Controller Module

Installation

- Installation should not be attempted without referring to the applicable *PLC Installation Manual*.
- Make sure rack power is off.
- Install in rack. (See figure 1)
- Turn on power.

The module should power up and blink the top LED for about 5 seconds. When the diagnostics have completed successfully the top LED stays. The middle LED is turned ON when a valid configuration for the module has been received from the CPU, and the IC66* I/O bus operation has been verified. The bottom LED is OFF under all conditions.

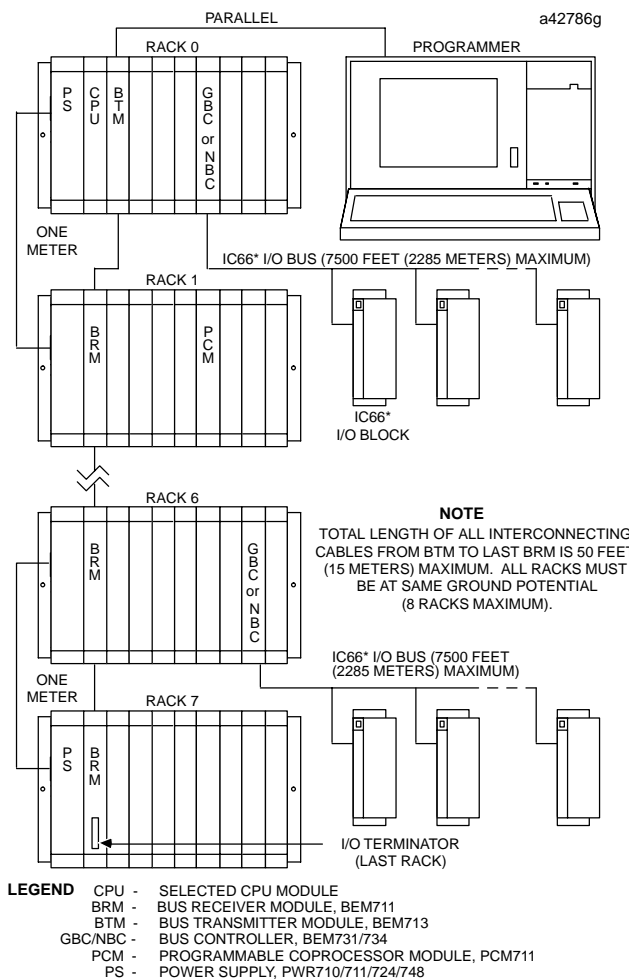

Figure 1. Typical PLC System Configuration

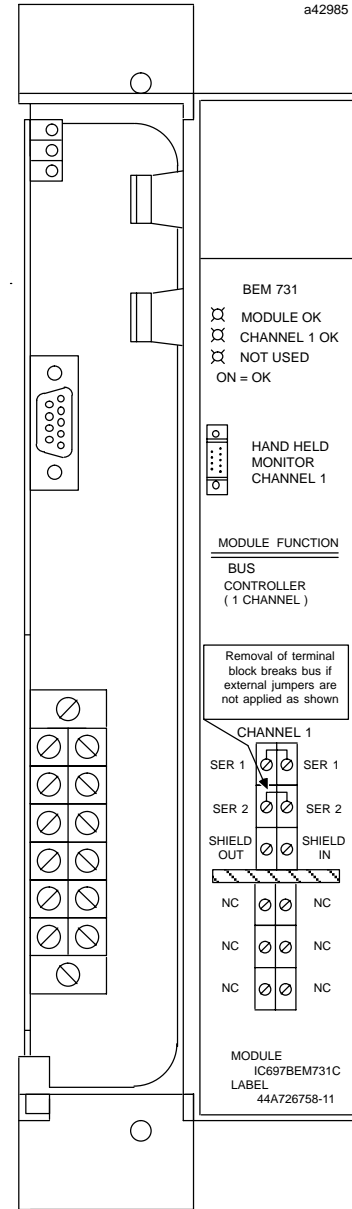

Figure 2. IC66 * Bus Controller Module User Details

Note

Refer to Figure 1, Bus Transmitter Module version IC697BEM713A must be installed to the right of the GBC/NBC or any other IC697 I/O modules. BTM version IC697BEM713B can be installed as shown in the figure (next to the CPU).

Bus Controller Module

GFK-0165G
August 1997

Removing a Module

The instructions below should be followed when removing a module from its slot in a rack.

- Grasp the board firmly at the top and bottom of the board cover with your thumbs on the front of the cover and your fingers on the plastic clips on the back of the cover.
- Squeeze the rack clips on the back of the cover with your fingers to disengage the clip from the rack rail and pull the board firmly to remove it from the backplane connector.
- Slide the board along the card guide and remove it from the rack.

Bus Controller Operation

Each IC66* I/O serial bus conveys data by passing a "token" among the devices on the bus.

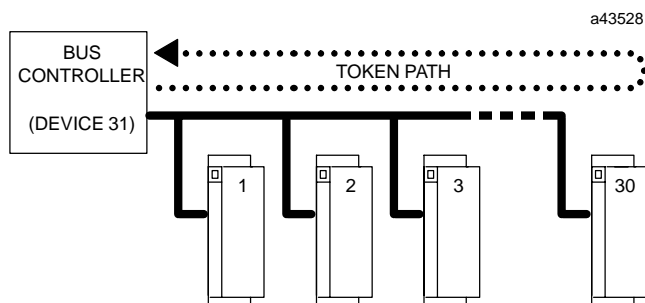

Figure 3. Bus Scan Cycle

During the bus scan, the Bus Controller:

- Receives all inputs from the I/O blocks.
- Receives any faults and sets diagnostic status references for use of the PLC CPU when it is accessed once each scan.

- Updates all outputs on the I/O blocks.
- Sends any command received from the CPU (for example, Clear Circuit Fault) to the appropriate device.

The IC66* I/O bus scan is independent of the IC697 PLC CPU sweep. The PLC CPU sweep is shown below.

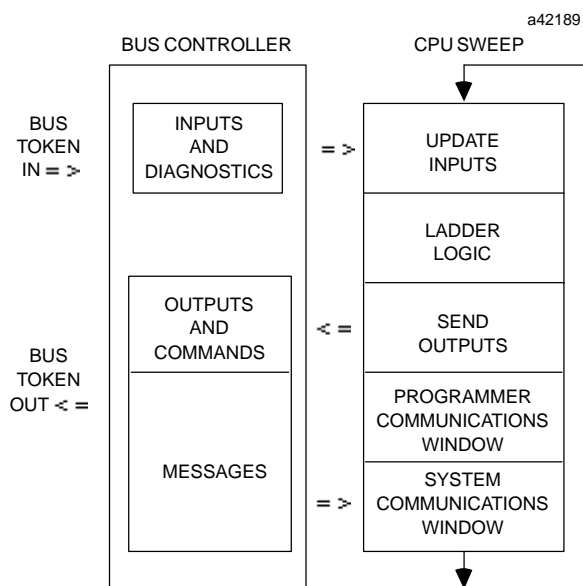

Figure 4. CPU Sweep

During the I/O service portions of the CPU sweep, the Bus Controller:

- Makes available to the CPU all discrete inputs and analog inputs.
- Receives current outputs and new commands from the CPU.
- Reports its status and that of the serial bus.

Communications Window

The Bus Controller can communicate with the CPU via the Communications window using these commands:

- 1 Pulse Test Outputs
- 2 ReadConfiguration
- 3 WriteConfiguration
- 4 ReadDiagnostics
- 5 Clear Circuit Fault
- 6 Clear All Circuit Faults
- 7 AssignMonitor
- 8 Enable/DisableOutputsGlobal
- 9 Enable/DisableData
- 10 Switch BSM
- 11 ReadDevice
- 12 Write Device
- 13 DequeueDatagram
- 14 SendDatagram
- 15 RequestDatagramReply

labeled 44A730116-G02 for those cables with 75 ohm impedance. Also supplied with each board are two prefabricated plugs for termination of both 75 ohm and 150 ohm cables at the last IC66* I/O block on the Serial bus. These plugs are labeled 44A713909-004 for 75 ohm termination and 44A713909-003 for 150 ohm termination.

Using shielded, twisted pair cable, create a serial bus connecting the Bus controller, I/O blocks, and other permanently-installed devices as shown in figure 5.

Caution

All cable used for one serial bus must be of the same type, or the bus will not work.

Other busses connected to the same CPU may use different types of cable (unless joined by a Bus Switching Module, as shown in figure 6). Cable specifications are found in Table 2 . For applications using Belden 9182 type cable, prefabricated cables are available in 15 inch and 36 inch lengths for interconnection of IC66* I/O blocks (not compatible with IC697 PLC IC66* Bus Controllers). One 75 ohm and one 150 ohm plug is included with each IC66* Bus Controller. See the Ordering Information on page 7 .

Hand Held Monitor Port (1PL)

Port 1 PL is for the Hand Held Monitor Connection.

IC66* Bus Field Terminal Connections (3PL)

Connector 3 PL contains the necessary connection points for the IC66* bus.

The serial bus must be terminated at each end by its characteristic impedance. If the Bus Controller is at the end of the bus, select the correct impedance for the cable length and type, as shown in table 2.

Included with each board are two small packages containing two resistors each. Use the resistors in the package labeled 44A730116-G01 for those cables with 150 ohm impedance. Use the resistors in the package

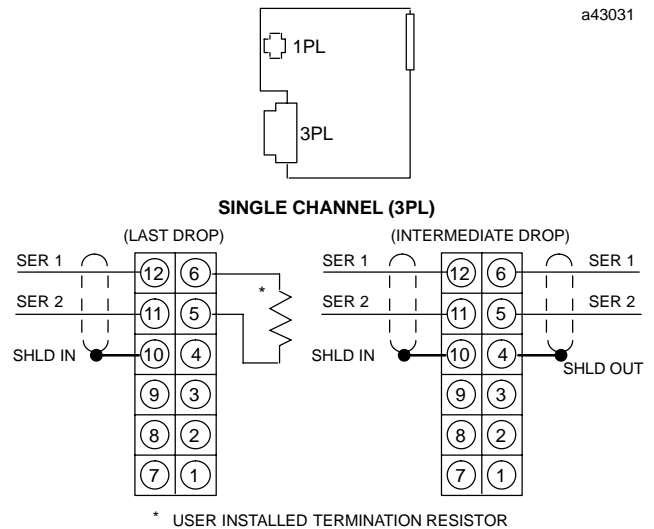

Figure 5. Wiring Diagram

Bus Controller Module

GFK-0165G
August 1997

Configuration

The module powers up with no assumed baud rate or serial bus address. The MS-DOS or Windows programming software configurator function defaults these to 153.6K baud standard and serial bus address of 31. After a valid configuration has been stored to the system, the PLC CPU transfers the configured baud rate and serial bus address to the module at the conclusion of the store and each time the Bus Controller is power cycled.

Setting the Bus Controller Baud Rate

The default baud rate is set at 153.6 Kbaud (standard). This rate supports an IC66* I/O bus up to 2000 feet in length. For greater distances the baud rate may be selected from the table below to support an IC66* I/O bus up to 7500 feet in length. (153.6 Kbaud Extended has additional delays between messages to support a longer bus length.)

Caution

Select the same baud rate for the Bus Controller as that used for other devices on the bus. *The bus will not operate unless all devices are set to the same baud rate.*

Table 1. IC66* Bus Length vs. Baud Rate

Baud Rate (K baud)	Maximum IC66* I/O Bus Length (Feet)
153.6 Standard	2000
153.6 Extended	3500
76.8	4500
38.4	7500

Other baud rates may be configured with the MS-DOS or Windows configuration software.

Setting the Serial Bus Address

The default serial bus address is 31. Other serial bus addresses may be assigned with the MS-DOS or Windows programming software configuration function.

Dual Serial Busses with a BSM

For some applications, a dual serial bus may be used to provide a backup communications path. Bus Switching Modules (BSMs) connect bus stubs containing a few IC66* I/O blocks with two serial busses, each with its own Bus Controller(s) or PCIM module(s). Blocks on a stub are connected using short lengths of non-terminated cable.

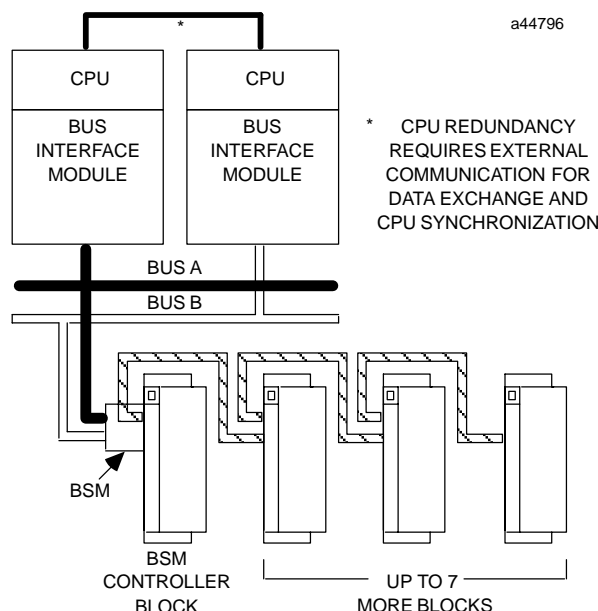

Figure 6. Dual Bus System

See Reference 4 for other redundant configurations.

Monitoring Bus Status

To display serial bus status, set the Hand Held Monitor to Monitor mode and attach to PL1. From the Block/Bus Status screen, press F4 (Bus).

```

S E R I A L B U S S T A T S
A C T V D E V I C E S =
S C A N T I M E =           mS
    
```

In a dual bus system, cable length and block placement should be planned well. Before installing blocks or cabling for a system using BSMs, read the Bus Switching Module Data Sheet (GFK-0072).

Dual busses are supported by two busses in different CPUs. The IC697 PLC will not support redundant busses in separate bus controllers in the same CPU.

GFK-0165G
August 1997

Bus Controller Module

Table 2. IC66* Bus Cable Specifications

Cable # & Make	Outer Diameter	Terminating Re- sistor -10% to +20% .5 Watt	Installation	Number of Conductors /AWG	Dielectric Voltage Rating	Ambient Temp. Rating	Maximum Length Cable Run, feet/meters at baud rate			
							153.6s	153.6e	76.8	38.4
(B)9182 (A)9B23 (C)4596	.350in. 8.89mm	150 ohms	In conduit	2 / #22 (.329mm ²)	30v	60°C	2000ft 606m	3500ft 1061m	4500ft 1364m	7500ft 2283m*
(B)89128	.322in 8.18mm	150 ohms	In plenum Noconduit	2 / #22 (.329mm ²)	150v	200°C	2000ft 606m	3500ft 1061m	4500ft 1364m	7500ft 2283m*
(B)	.270in 6.86mm	120 ohms	Double Shields	2 / #24 (.199mm ²)	30v	80°C	1000ft 303m	1500ft 455m	2500ft 758m	3500ft 1061m*
(B)9207	.330in 8.38mm	100 ohms	In conduit	2 / #20 (.519mm ²)	300v	80°C	1500ft 455m	2500ft 758m	3500ft 1061m	6000ft 1818m*
(B)89207 (A)4794	.282in 7.16mm	100 ohms	In plenum Noconduit	2 / #20 (.519mm ²)	150v	200°C	1500ft 455m	2500ft 758m	3500ft 1061m	6000ft 1818m*
(B)9815	.330in 8.38mm	100 ohms	Direct burial	2 / #20 (.519mm ²)			1500ft 455m	2500ft 758m	3500ft 1061m	6000ft 1818m*
(B)9855	.315in 8.00mm	100 ohms	In conduit	4 (2 pair) #22 (.329 mm ²)	150v	60°C	1200ft 364m	1700ft 516m	3000ft 909m	4500ft 1364m*
(B)89696 (B)89855	.274in 6.96mm	100 ohms	In plenum No con- duit fire re- sist	4 (2 pair) #22 (.329 mm ²)	150v	200°C	1200ft 364m	1700ft 516m	3000ft 909m	4500ft 1364m*
(B)9463 (A)9814	.243in 6.17mm	75ohms	In conduit	2 / #20 (.519mm ²)	150v	60°C	800ft 242m	1500ft 455m	2500ft 758m	3500ft 1061m
(B)9302	.244in 6.20mm	75 ohms	In conduit	4 (2 pair) #22 (.329 mm ²)	300v	80°C	200ft 30m	500ft 152m	1200ft 333m	2500ft 758m

Notes: A = Alpha, B = Belden, C = Consolidated
• Limited to 16 taps at 38.4 K baud.

Table 3. References

Reference	Title
1	ProgrammingSoftware User's Manual
2	ProgrammableControllerReferenceManual
3	ProgrammableControllerInstallationManual
4	Bus Controller User's Manual

Bus Controller Module

GFK-0165G
August 1997

Table 4. Specifications for IC697BEM731/734 †

Current required from 5V Bus VME	1.3 amps System designed to support the VME standard C.1
-------------------------------------	---

† Refer to GFK-0867B, or later for product standards and general specifications. For installations requiring compliance to more stringent requirements (for example, FCC or European Union Directives), refer to *Installation Requirements for Conformance to Standards*.

Table 5. Ordering Information

Description	Catalog Number
IC660/IC66 Bus Controller	IC697BEM731 IC697BEM734
Communications Cable (Belden 9182 type) 15 inch, qty. 3 36 inch, qty. 1	IC660BLC001 IC660BLC003
Bus Terminator Plugs 150 ohm, qty. 4 75 ohm, qty. 4	IC660BLM506 IC660BLM508

Note: For Conformal Coat option, or Low Temperature Testing option please consult the factory for price and availability.

