

# User Manual WEB

## Charger for Lead Acid Batteries

### **EN** User Manual

Language specific user manuals are available on  
[www.mascot.no/downloads/usermanuals](http://www.mascot.no/downloads/usermanuals)

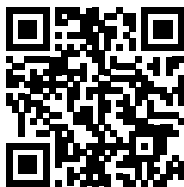

Bruksanvisning  
Käyttöohjeet  
Bedienungsanleitung  
Mode d'emploi  
Manual de instrucciones  
Istruzioni per l'uso



**MASCOT ELECTRONICS AS**  
P.O.Box 177, N-1601 Fredrikstad, NORWAY  
Phone: +47 69 36 43 00 • Telefax: +47 69 36 43 01  
E-mail: [sales@mascot.no](mailto:sales@mascot.no) • Web: [www.mascot.no](http://www.mascot.no)



## IMPORTANT SAFETY INSTRUCTIONS!



**TO REDUCE THE RISK OF FIRE AND ELECTRIC SHOCK:**

**READ THROUGH THESE INSTRUCTIONS PRIOR TO USING THE PRODUCT.**

**CAREFULLY FOLLOW THESE INSTRUCTIONS WHEN USING THE PRODUCT.**

**RETAIN THESE INSTRUCTIONS FOR FUTURE REFERENCE.**



**CAUTION! DOUBLE POLE / NEUTRAL FUSING!**



This product is designed for indoor use.  
(Not applicable to products marked "IP67")

### **IP41    IP44    ☉IP67**

A version of this product marked "IP41" may be available. This version is protected against ingress of solid objects larger than 1.0 mm and the effects of vertically falling drops of water according to standard EN/IEC 60529.

A version of this product marked "IP44" may be available. This version is protected against ingress of solid objects larger than 1.0 mm and the effects of water splashed against the enclosure from any direction according to standard EN/IEC 60529.

A version of this product, marked with a symbol with two drops of water and/or "IP67", may be available. This version is filled with a potting compound and is dust-tight and protected against the effects of temporary immersion in water accor-

ding to standard EN/IEC 60529, but must not be immersed in water for longer periods of time.



Products marked with the "double square symbol" are double insulated (Insulation Class II). Products without this mark are Class I (relies on safety earth for protection).

**WARNING:** To avoid risk of electric shock, Class I products must only be connected to a supply mains with protective earth.



At the end of their service life electric and electronic equipment and their accessories shall not be discarded with the municipal waste but be disposed of using separate collection, treatment, recovery/recycling and environmentally sound disposal. This also applies to any potentially bio hazardous parts and accessories. If in doubt; contact your local authorities to determine the proper method.

Technical specifications for your product:  
See tables, the marking on the product or [www.mascot.no](http://www.mascot.no)

## Cautions to observe prior to use

- The intended use for this product is to charge a battery or a battery powered electrical accessory (NiCd/NiMH, Lead-Acid, Lithium-Ion or LiFePO<sub>4</sub> batteries) or to be used as a Power Supply to power an electrical accessory. Please see the marking on the product you have to verify the type of product you have and read the applicable instructions and technical specifications included with this manual.
- This product may be used by unskilled operators, under the condition that these instructions are followed.
- Unskilled operators may contact the supplier or manufacturer for assistance, if needed, in setting up, using or maintaining this product and to report unexpected operation or events.
- This appliance can be used by children aged from 8 years and above and persons with reduced physical, sensory or mental capabilities or lack of experience and knowledge if they have been given supervision or instruction concerning use of the appliance in a safe way and understand the hazards involved. Children shall not play with the appliance.
- Do not allow animals to come into contact with this product. Some animals are known to cause damage to cables etc which may be a potential for risk of electric shock and excessive temperatures. Also, cables and small parts may represent a strangulation risk for the animal.
- If the product is equipped with a mains cord, please check that the cord is not damaged. If the cord is damaged, the product must not be used until the cord is replaced. Replacement should be carried out by qualified personnel.
- The mains socket outlet used should always be easily accessible to facilitate immediate removal of the products mains supply should an operational error occur during use. If the product has a detachable mains cord the appliance coupler may be used as a disconnect device.
- The product is “switched on” by inserting the mains plug into the mains socket and “switched off” by disconnecting the mains plug from the mains socket.
- The product may be connected to an IT type mains supply.
- For use in U.S.A.:
  - Be sure to use 125V 15A receptacle configuration before plugging in.
  - Use a UL817-standard compliant mains cord (plug type NEMA 1-15, cord type SJT or SVT).
- For use outside U.S.A.:
  - Use a mains cord compliant with the country specific requirements.
- The time from powering this product until its full function starts may exceed 15 seconds.
- Should an operational error or unexpected change in the performance occur during use; disconnect the product from the mains immediately by disconnecting the mains plug from the mains socket and contact the supplier
- When not in use please think about disconnecting the product from the mains. This will reduce the risk of hazards, reduce the products environmental impact and save electricity costs.
- To avoid overheating make sure there is sufficient room for the circulation of air around the product when in use. Do not cover it up.
- Even though this product complies with relevant safety standards it should not be in contact with human skin for long periods as some people may get allergies or injuries from long-term contact with moderate temperatures and/or plastic materials.
- Prior to using this product with accessories and/or interconnected equipment please carefully read its respective User Manuals.
- If the product is supplied with exchangeable output plugs, please see separate page for assembly.

- Output cables having a modular plug ( similar to a telephone connector) must never be connected to a telephone outlet.
  - Products with a welded plastic housing are not repairable. Please contact your supplier for replacement part.
  - This product contains hazardous voltages and there are no user replaceable parts inside the product. Never attempt to remove the cover.
  - **WARNING:** No modification of this equipment is allowed. Any repair/service should be carried out by qualified personnel who may get assistance by contacting the manufacturer or the manufacturer's agent.
  - Products specified to have automatic polarity protection must be switched off if a battery is connected with reverse polarity. The protection will be automatically reset when the polarity has been corrected.
  - In chargers specified to have a replaceable fuse as polarity protection the fuse must be replaced if the battery has been connected with reverse polarity. When replacing the fuse; a fuse of the same type and rating must be used.
  - If the product is specified to comply with the standard for Medical Electrical Equipment (standards based on IEC60601-1) it complies with some of the requirements for medical electrical equipment and may be used in medical applications and hospital environments.
  - The product must not be used in the vicinity of flammable anesthetic gases or in other environments with flammable or explosive atmosphere.
  - If the product is specified to comply with the standard for Medical Electrical Equipment for Home Healthcare Environment (standard IEC60601-1-11) it may be used in medical applications used in a home healthcare environment.
- NOTE: Products relying on safety earth for protection (Class I) may not be used in home healthcare environment unless they are permanently wired to the building installation: Installation must only be carried out by qualified service personnel, following the below instructions:
- The protective earth conductor must be min. 0.75 mm<sup>2</sup>.
  - Connect the protective earth conductor to the external protective earthing system.
  - Verify that the protective earth terminal used is connected to the external protective earthing system.
  - Verify the integrity of the external protective earthing system.
- This product converts the mains voltage to a safety extra low voltage. Some products may be treated as Applied Part (Type BF) according to standard EN/IEC 60601-1 and may come in physical contact with a patient.
  - This product must be operated in an environment within temperature range +5 to +40°C, humidity 15 - 93 % RH and atmospheric pressure 70 - 106 kPa (700 - 1060 hPa).
  - Expected service life of this product and accessories delivered with this product is three (3) years, if operated as indicated above. However; the guarantee times indicated in document "TERMS OF SALES AND DELIVERY FOR MASCOT AS" apply (available at [www.mascot.com](http://www.mascot.com)).
  - Environmental parameters during transport and storage between uses: temperature range -25 to +85 °C, humidity 15 - 93% RH NC and atmospheric pressure 70 - 106 kPa (700 - 1060 hPa).
  - If stored for longer periods of time the environmental parameters should be within the temperature range +5 to +35°C, humidity range 10 - 75% RH NC and atmospheric pressure 70 - 106 kPa (700 - 1060 hPa) to maintain the products expected service life.
  - Expected shelf life of this product is one (1) year, if stored as indicated above.
  - This product complies with the requirements to electromagnetic compatibility for medical electric equipment and for use in residential, office or light industrial environment but all

electric products imply a potential for electromagnetic or other interference between the product and other devices. If such interference is suspected please disconnect the product from the mains and consult a qualified technician, your supplier or the manufacturer.

- No special maintenance procedure is required but if the product gets dusty or dirty it should be wiped clean using a dry cloth while the product is disconnected from the mains. No other maintenance should be necessary.
- For products having a plastic casing, please avoid any contact with lotions, oils, grease and solvents as most types of plastic may be

degraded by such chemicals. Also make sure to position, operate and store such products away from UV-light and direct sunlight.

- Position, operate and store this product only under reasonable foreseeable environmental conditions with respect to magnetic fields, EM-fields, electrostatic discharges, pressure or variations in pressure, acceleration etc.
- If this product is used with or mounted in a vehicle it may only be used when the vehicle is not in use.
- When in use, position this product so that the label can be read – within 40 cm of the operator.

## **Cautions to observe prior to charging Lead-Acid batteries**

- Lead-Acid chargers are designed for charging Lead-Acid batteries only.
- Make sure you have the correct battery charger for the Lead-Acid battery you wish to charge. For safety reasons, individual battery types should have a minimum capacity - please refer to the specifications at the end of this manual.
- Do not attempt to charge batteries that are not rechargeable.
- Please check that the specifications for your battery allows for the maximum charge current indicated on the charger.
- Please check that the specifications for your battery allows for the environmental conditions present during charging.
- If in doubt; contact the battery manufacturer for the specific battery.
- Before charging flooded lead-acid batteries, check the electrolyte level. If necessary top up with distilled water up to 5-10 mm over the lead-plates.
- Old, sulfated Lead-Acid batteries usually have a reduced capacity and are difficult to charge. The charge current will fall rapidly as if the battery had received a full charge. Even though a battery in this condition should be replaced, it will retain a small charge.
- As explosive gases may arise during charging lead-acid batteries the charger and the battery should be placed in a well-ventilated area during charging. Avoid sparks and open flames.
- Make sure the charger is disconnected from the mains. Connect the charger to the battery before connecting it to the mains (to avoid possible sparks).
- Please ensure correct polarity when connecting to the battery terminals. Reverse polarity connection may, in some chargers, result in a fuse blowing, leaving the charger useless.
- When charging batteries other than vehicle batteries, it is recommended that you connect the charger to the mains before connection is made to the battery. This will reduce the sparks

that may occur due to difference in potential between charger terminals and battery terminals. Note! Make sure the charger terminals are not short-circuited and ensure that the polarity is correct.

- If the charger is equipped with battery clips; first connect the positive clip (RED) to the positive battery pole, then connect the other clip (BLACK) to the battery's negative pole.
- To charge batteries in vehicles; first connect the positive clip (RED) to the positive battery pole (The one not connected to the vehicles chassis), then connect the other clip (BLACK) to the vehicle's chassis - a good distance from the battery and fuel system (fuel hoses, fuel pump etc.).
- The charge cycle starts when the charger is connected to the mains.
- If the charger is disconnected from the mains voltage during a charge cycle the charger will start a new charge cycle when it is reconnected to the mains.
- When charging is complete, disconnect the charger from the mains before removing battery connections.

If the charger is equipped with battery clips:

first disconnect the clip from the battery's positive pole then the other from the negative battery pole/vehicle chassis, in this order.

- The recommended minimum battery capacity for which the specific charger can be used vary from battery to battery. Some do not have a capacity restriction at the specified boost voltage level while others have restrictions. Please follow the datasheet and recommendations from the battery manufacturer. In our tables we use typical C/5 as a maximum charge current for Lead Acid cells. C/5 means that charge current for a 10Ah battery should be max 2A. Thus the typical minimum capacity recommendation is then 10Ah for a 2A charger. For max battery capacity we have used 50 times charge current for chargers with timer (and/or uC) and 50 times current detection levels for chargers using only this termination method. For a 2A charger with 0.25A current detection level the max capacity recommended will be  $50 \times 0.25A = 12.5Ah$ . Again this is just typical recommendations. Please read recommendations and datasheets from battery manufacturer.

# Explanation of Lead-Acid charge cycle

(See tables for methods for each charger model)

## Charging method A

### STEP 1 - BOOST CHARGE

To start a charge cycle; connect the charger to the mains.

The charger is in constant current mode, charging with the maximum current indicated on the charger, the LED-indication on the charger is ORANGE. This step allows rapid charging of your battery until the battery reaches typically 80 - 95% of its capacity.



### STEP 2 – TOP-UP CHARGE

The charger is in constant voltage mode, charging with a decreasing current until the current is below the chargers charge termination level (indicated on the charger).

The LED-indication on the charger is ORANGE. The battery is charged to its full capacity at the end of this step



### STEP 3 – FLOAT CHARGE

The LED-indication on the charger is GREEN and the battery is fully charged.

The charger is in standby mode. The charge voltage is at standby level and the charger may remain connected to the battery.

The charger will return to boost charging if the battery is used.

A load larger than the cut-off current will initiate a new charge cycle.

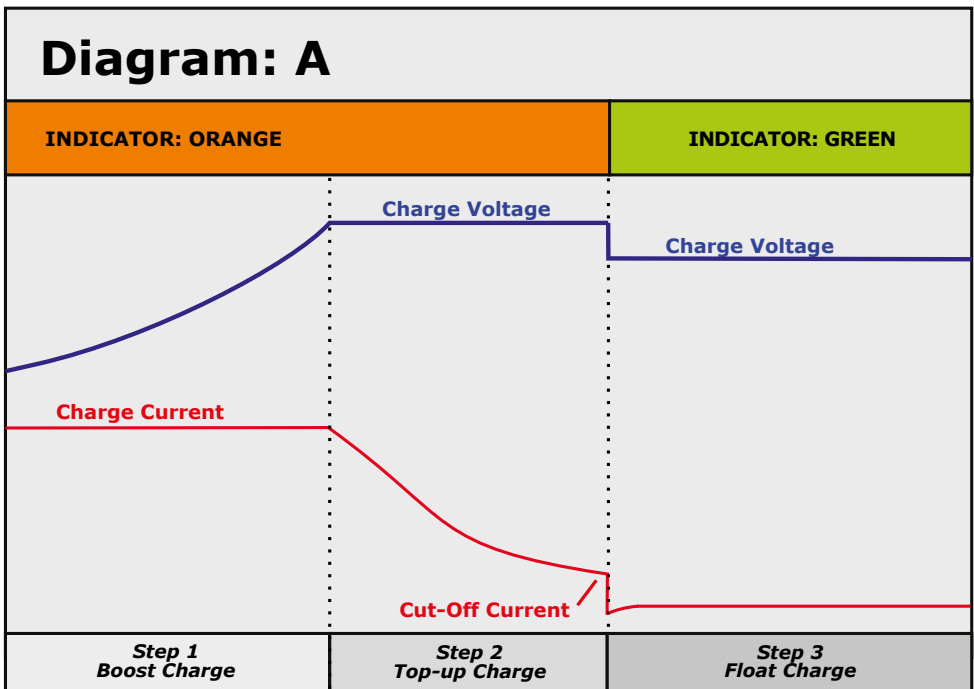

## Charging method B

### STEP 1 - BOOST CHARGE

To start a charge cycle; connect the charger to the mains.

The charger is in constant current mode, charging with the maximum current indicated on the charger, the LED-indication on the charger is ORANGE.



### STEP 2 – TOP-UP CHARGE

The charger is in constant voltage mode, charging with a decreasing current until the current is below the chargers charge termination level (indicated on the charger). The LED-indication will turn to YELLOW during Top-up charge. The battery is typically 90-95% fully charged when the LED indicator changes to yellow. The charger stays in this mode until the charge current decreases to charge termination level. The battery is charged to its full capacity at the end of this step

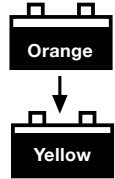

### STEP 3 – FLOAT CHARGE

The LED-indication on the charger is GREEN and the battery is fully charged.

The charger is in standby mode. The charge voltage is at standby level and the charger may remain connected to the battery

The charger will return to boost charging if the battery is used.

A load larger than the cut-off current will initiate a new charge cycle.

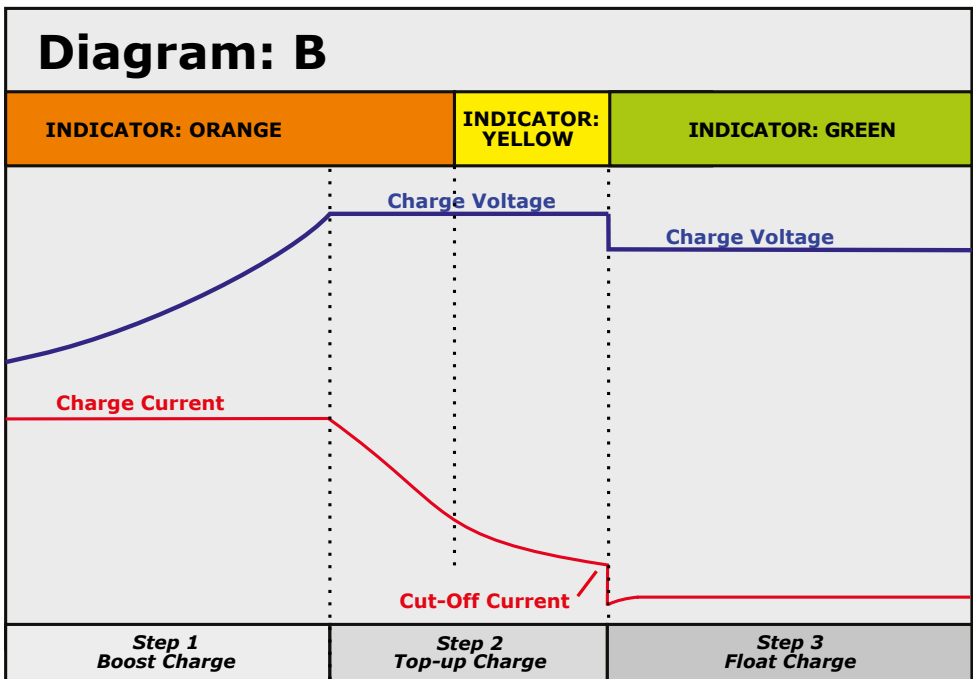



## Charging method C

### STEP 1 - BOOST CHARGE

To start a charge cycle; connect the charger to the mains.

The charger is in constant current mode, charging with the maximum current indicated on the charger, the LED-indication on the charger is ORANGE (or RED 9640). This step allows rapid charging of your battery until the battery reaches typically 80 - 95% of its capacity.



### STEP 2 – TIMER CHARGE

The charger is in constant voltage mode, charging with a decreasing current.

The LED-indication on the charger is YELLOW. The charger is now in timer mode indicated by the YELLOW LED and will remain in this mode until time interval is completed. The battery is charged to its full capacity at the end of this step



### STEP 3 – FLOAT CHARGE

The LED-indication on the charger is GREEN and the battery is fully charged.

The charger is in standby mode. The charge voltage is at standby level which means that the charger can continue to be connected to the battery.

The charger will return to boost charging if the battery is used. A load current equal to the constant current level will initiate a new charge cycle.

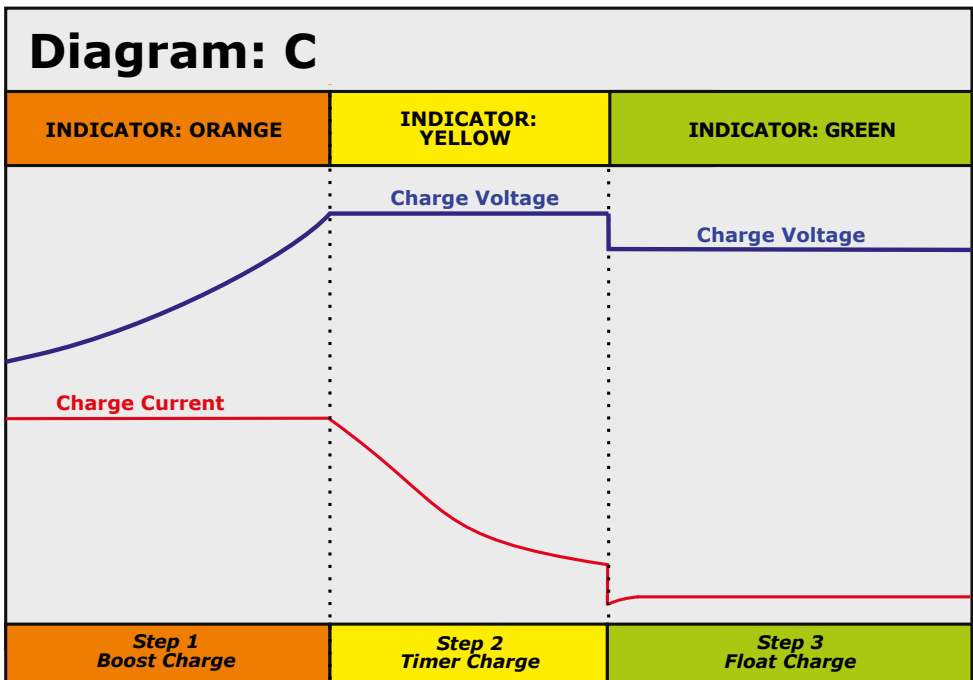

## Charging method D

### STEP 1 - BOOST CHARGE

LED-indicator: YELLOW

The charger is in constant current mode (CC), charging with the maximum current until battery voltage reach Top-Up level.

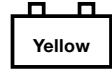

### STEP 2 – TOP-UP CHARGE

The charger is in constant voltage mode. The LED-indication will be FLASHING YELLOW during Top-up charge. The charger stays in this mode until the charge current decreases to charge termination level or the Top-Up Charge Timer runs out. The battery is charged to its full capacity at the end of this step



### STEP 3 – FLOAT CHARGE

The LED-indication on the charger is GREEN and the battery is fully charged.

The charger is in standby mode. The charge voltage is at standby level and the charger may remain connected to the battery.

The charger will return to boost charge if the battery is used.

A load larger than the cut-off current will initiate a new charge cycle.

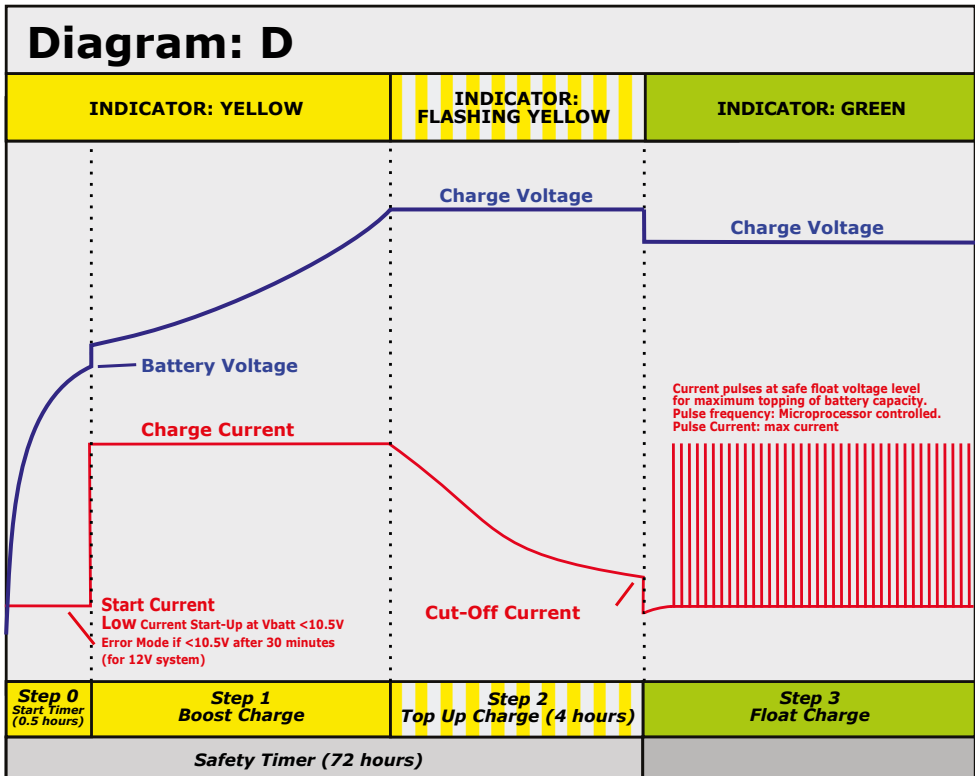

## How to connect exchangeable DC-output plugs

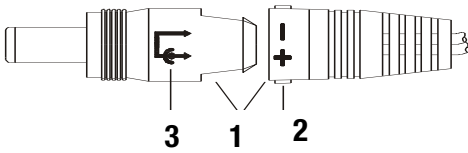

1. To connect for desired polarity, both plug ends are clearly marked.
2. When connected, the female plug is also marked on each side to identify plug polarity.
3. Shows the center polarity of the plug.

## How to connect exchangeable AC-plugs

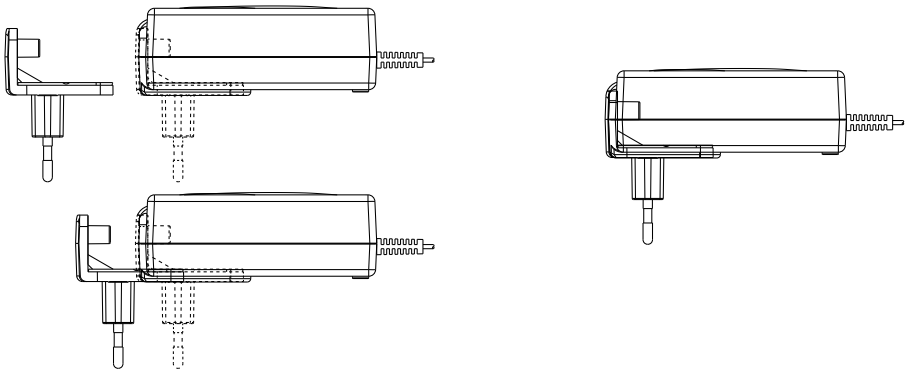

### The following exchangeable AC plugs are available:

Type 018110 - "EURO"	250V 2.5A (EN50075/IEC83 C5 II)
Type 018111 - "US"	125V 2.5A (NEMA 1-15 / CSA-C22.2 No.42)
Type 018112 - "UK"	250V 13A (BS 1363)
Type 018114 - "AUS"	250V 10A (AS/NZS 3112)

Mains Cord Set is available on request if you wish your product to be "DeskTop"

## Charge diagram A

	Input voltage	Charge LED indicator	6V	12V	24V	36V	48V
<b>2240</b> <b>2241</b>	100-240Vac 50-60Hz	Orange CC ch.: Orange CV ch.: Green Float ch.: Rec. batt. capacity:	1.3A < 7.35V 7.35V > 250mA 6.85V < 250mA 6.5Ah – 12.5Ah	1A < 14.7V 14.7V > 250mA 13.7V < 250mA 5Ah – 12.5Ah	0.5A < 29.4V 29.4V > 250mA 27.4V < 250mA 2.5Ah – 12.5Ah	0.35A < 44.1V 44.1V > 150mA 41.1V < 150mA 1.7Ah – 7.5Ah	0.27A < 58.8V 58.8V > 100mA 54.8V < 100mA 1.4Ah – 5Ah
<b>2740</b>	100-240Vac 50-60Hz	Orange CC ch.: Orange CV ch.: Green Float ch.: Rec. batt. capacity:	1.0A < 7.35V 7.35V > 200mA 6.85V < 200mA 5Ah – 10Ah	0.7A < 14.7V 14.7V > 200mA 13.7V < 200mA 3.5Ah – 10Ah	0.35A < 29.4V 29.4V > 100mA 27.4V < 100mA 1.8Ah – 5Ah	0.24A < 44.1V 44.1V > 100mA 41.1V < 100mA 1.2Ah – 5Ah	0.18A < 58.8V 58.8V > 50mA 54.8V < 50mA 0.9Ah – 2.5Ah

## Charge diagram B

	Input voltage	Charge LED indicator	6V	12V	24V	36V	48V
<b>2541</b> <b>2542</b>	100-240Vac 50-60Hz	Orange CC ch.: Orange CV ch.: Yellow CV ch.: Green Float ch.: Rec. batt. capacity:	2.7A < 7.35V 7.35V > 1.2A 7.35V < 1.2A 6.85V < 250mA 11Ah – 12.5Ah	2.2A < 14.7V 14.7V > 1A 14.7V < 1A 13.7V < 250mA 11Ah – 12.5Ah	1.2A < 29.4V 29.4V > 0.5A 29.4V < 0.5A 13.7V < 250mA 6Ah – 12.5Ah	0.8A < 44.1V 44.1V > 0.4A 44.1V < 0.4A 41.1V < 250mA 4Ah – 12.5Ah	0.6A < 58.8V 58.8V > 0.25A 58.8V < 0.25A 54.8V < 100mA 3Ah – 5Ah

<b>2544</b>	10-30Vdc	Orange CC ch.: Orange CV ch.: Yellow CV ch.: Green Float ch.: Rec. batt. capacity:	2.7A < 7.35V 7.35V > 1.15A 7.35V < 1.15A 6.85V < 250mA 12Ah – 12.5Ah	2A < 14.7V 14.7V > 0.85A 14.7V < 0.85A 13.7V < 250mA 10Ah – 12.5Ah	1.2A < 29.4V 29.4V > 0.5A 29.4V < 0.5A 27.4V < 250mA 6Ah – 12.5Ah	0.8A < 44.1V 44.1V > 0.4A 44.1V < 0.4A 41.1V < 250mA 4Ah – 12.5Ah	0.6A < 58.8V 58.8V > 0.25A 58.8V < 0.25A 54.8V < 100mA 3Ah – 5Ah
<b>3044</b>	10-30Vdc	Orange CC ch.: Orange CV ch.: Yellow CV ch.: Green Float ch.: Rec. batt. capacity:	4A < 7.35V 7.35V > 2A 7.35V < 2A 6.85V < 500mA 20Ah – 25Ah	4A < 14.7V 14.7V > 2A 14.7V < 2A 13.7V < 500mA 20Ah – 25Ah	2A < 29.4V 29.4V > 0.85A 29.4V < 0.85A 27.6V < 250mA 10Ah – 12.5Ah	1.5A < 44.1V 44.1V > 0.7A 44.1V < 0.7A 41.4V < 250mA 7.5Ah – 12.5Ah	1A < 58.8V 58.8V > 0.5A 58.8V < 0.5A 54.8V < 250mA 5Ah – 12.5Ah
<b>2641 per chan- nel</b>	100-240Vac 50-60Hz	Orange CC ch.: Orange CV ch.: Yellow CV ch.: Green Float ch.: Rec. batt. capacity:	2.7A < 7.35V 7.35V > 1.15A 7.35V < 1.15A 6.85V < 250mA 12Ah – 12.5Ah	2A < 14.7V 14.7V > 0.8A 14.7V < 0.85 13.7V < 250mA 10Ah – 12.5Ah	1.0A < 29.4V 29.4V > 0.4A 29.4V < 0.4A 27.4V < 250mA 5Ah – 12.5Ah	0.6A < 44.1V 44.1V > 0.35A 44.1V < 0.35A 41.1V < 250mA 3Ah – 12.5Ah	0.5A < 58.8V 58.8V > 0.35A 58.8V < 0.35A 54.8V < 250mA 2.5Ah – 12.5Ah
<b>2840 3140</b>	220-240Vac 50-60Hz	Orange CC ch.: Orange CV ch.: Yellow CV ch.: Green Float ch.: Rec. batt. capacity:	8.5A < 7.35V 7.35V > 4.25A 7.35V < 4.25A 6.85V < 1.6A 42.5Ah – 80Ah	7A < 14.7V 14.7V > 3.5A 14.7V < 3.5A 13.7V < 1.6A 35Ah – 80Ah	3.5A < 29.4V 29.4V > 1.7A 29.4V < 1.7A 27.4V < 0.8A 17.5Ah – 40Ah	2.3A < 44.1V 44.1V > 1.1A 44.1V < 1.1A 41.1V < 0.5A 11.5 – 40Ah	1.7A < 58.8V 58.8V > 0.9A 58.8V < 0.9A 54.8V < 0.4A 8.5Ah – 20Ah
<b>3240</b>	115Vac/ 230Vac 50-60Hz	Orange CC ch.: Orange CV ch.: Yellow CV ch.: Green Float ch.: Rec. batt. capacity:	8.5A < 7.35V 7.35V > 4.25A 7.35V < 4.25A 6.85V < 1.6A 42.5Ah – 80Ah	7A < 14.7V 14.7V > 3.5A 14.7V < 3.5A 13.7V < 1.6A 35Ah – 80Ah	3.5A < 29.4V 29.4V > 1.7A 29.4V < 1.7A 27.4V < 0.8A 17.5Ah – 40Ah	2.3A < 44.1V 44.1V > 1.1A 44.1V < 1.1A 41.1V < 0.5A 11.5 – 40Ah	1.7A < 58.8V 58.8V > 0.9A 58.8V < 0.9A 54.8V < 0.4A 8.5Ah – 20Ah
<b>3340</b>	220-240Vac 50-60Hz	Orange CC ch.: Orange CV ch.: Yellow CV ch.: Green Float ch.: Rec. batt. capacity:	N.A.	N.A.	N.A.	N.A.	11A < 58.8V 58.8V > 6A 58.8V < 6A 54.8V < 4A 55Ah – 200Ah

## Charge diagram C

	Input voltage	Charge LED indicator	6V	12V	24V	36V	48V
<b>9640</b> <b>9641</b>	220-240Vac (115Vac) 50-60Hz	Red/Orange CC ch.: Yellow Timer CV ch.: Green Float ch.: Rec. batt. capacity:	2.7A < 7.35V 7.35V < 2.7A (2h) 6.9V 13.5Ah – 135Ah	2.7A < 14.7V 14.7V < 2.7A (2h) 13.8V 13.5Ah – 135Ah	1.5A < 29.5V 29.5V < 1.5A (2h) 27.6V 7.5Ah – 75Ah	1.0A < 44.1V 44.1V < 1A (2h) 41.1V 5Ah – 50Ah	N.A.
<b>9940</b> <b>9941</b>	100-240Vac 50-60Hz	Orange CC ch.: Yellow Timer CV ch.: Green Float ch.: Rec. batt. capacity:	N.A.	2.3A < 14.7V 14.7V < 2.0A (2h) 13.8V 11.5Ah – 115Ah	1.3A < 29.5V 29.5V < 1.3A (2h) 27.6V 6.5Ah – 65Ah	0.9A < 44.1V 44.1V < 0.9A (2h) 41.4V 4.5Ah – 45Ah	N.A.
<b>2040</b> <b>2041</b> <b>2042</b> <b>2140</b>	100-240Vac 50-60Hz	Orange CC ch.: Yellow Timer CV ch.: Green Float ch.: Rec. batt. capacity:	N.A.	4A < 14.7V 14.7V < 4A (2h) 13.8V 20Ah – 200Ah	2A < 29.5V 29.5V < 2A (2h) 27.6V 10Ah – 100Ah	1.4A < 44.1V 44.1V < 1.4A (2h) 41.4V 7Ah – 70Ah	1A < 58.8V 58.8V < 1A (4h) 54.8V 5Ah – 50Ah
<b>9840</b>	220-240Vac 50-60Hz	Orange CC ch.: Yellow Timer CV ch.: Green Float ch.: Rec. batt. capacity:	5A < 7.35V 7.35V < 5A (2h) 6.85V 25Ah – 250Ah	5A < 14.7V 14.7V < 5A (2h) 13.7V 25Ah – 250Ah	2.5A < 29.4V 29.4V < 2A (2h) 27.4V 12.5Ah – 125Ah	1.7A < 44.1V 44.1V < 1.7A (2h) 41.1V 8.5Ah – 85Ah	1.3A < 58.8V 58.8V < 1.3A (4h) 54.8V 6.5Ah – 65Ah
<b>9740</b> <b>2047</b>	220-240Vac 50-60Hz	Orange CC ch.: Yellow Timer CV ch.: Green Float ch.: Rec. batt. capacity:	10A < 7.35V 7.35V < 10A (4h) 6.85V 50Ah – 500Ah	10A < 14.7V 14.7V < 10A (4h) 13.7V 50Ah – 500Ah	5A < 29.4V 29.4V < 5A (4h) 27.4V 25Ah – 250Ah	3.3A < 44.1V 44.1V < 5A (4h) 40.8V 16.5Ah – 165Ah	2.5A < 58.8V 58.8V < 2.5A (4h) 54.8V 12.5Ah – 125Ah

<b>2043</b>	100-240Vac 50-60Hz	Orange CC ch.: Yellow Timer CV ch.: Green Float ch.: Rec. batt. capacity:	10A < 7.35V 7.35V < 10A (4h) 6.85V 50Ah – 500Ah	10A < 14.7V 14.7V < 10A (4h) 13.7V 50Ah – 500Ah	5A < 29.4V 29.4V < 5A (4h) 27.4V 25Ah – 250Ah	3.3A < 44.1V 44.1V < 5A (4h) 40.8V 16.5Ah – 165Ah	2.5A < 58.8V 58.8V < 2.5A (4h) 54.8V 12.5Ah – 125Ah
<b>2044</b> <b>2045</b>	220-240Vac 50-60Hz	Orange CC ch.: Yellow Timer CV ch.: Green Float ch.: Rec. batt. capacity:	20A(25A) < 7.35V 7.35V < 20A/25A (4h) 6.85V 100Ah – 1000Ah	20A/25A < 14.7V 14.7V < 20A/25A (4h) 13.7V 100Ah – 1000Ah	10A < 29.4V 29.4V < 10A (4h) 27.4V 50Ah – 500Ah	6.7A < 44.1V 44.1V < 6.7A (4h) 41.1V 33.5Ah – 335Ah	5A < 58.8V 58.8V < 5A (4h) 54.8V 25Ah – 250Ah
<b>2640</b> <b>per</b> <b>chan-</b> <b>nel</b>	220-240Vac 50-60Hz	Orange CC ch.: Yellow Timer CV ch.: Green Float ch.: Rec. batt. capacity:	10A < 7.35V 7.35V < 10A (4h) 6.85V 50Ah – 500Ah	10A < 14.7V 14.7V < 10A (4h) 13.7V 50Ah – 500Ah	5A < 29.4V 29.4V < 5A (4h) 27.4V 25Ah – 250Ah	3.3A < 44.1V 44.1V < 5A (4h) 41.1V 16.5Ah – 165Ah	2.5A < 58.8V 58.8V < 2.5A (4h) 54.8V 12.5Ah – 125Ah
<b>9541</b> <b>per</b> <b>chan-</b> <b>nel</b>	220-240Vac 50-60Hz	Orange CC ch.: Yellow Timer CV ch.: Green Float ch.: Rec. batt. capacity:	25A < 7.35V 7.35V < 25A (4h) 6.85V 125Ah – 1250Ah	25A < 14.7V 14.7V < 25A (4h) 13.7V 125Ah – 1250Ah	10A < 29.4V 29.4V < 10A (4h) 27.4V 50Ah – 500Ah	6.7A < 44.1V 44.1V < 6.7A (4h) 41.1V 33.5Ah – 335Ah	5A < 58.8V 58.8V < 5A (4h) 54.8V 25Ah – 250Ah

## Charge diagram D

	Input voltage	Charge LED indicator	6V	12V	24V	36V	48V
<b>2745</b>	115Vac/ 230Vac 50-60Hz	Yellow CC ch.: Flash Yellow CV ch.: Green Float ch.: Rec. batt. capacity:	20A < 7.35V 7.35V 2.5 – 20A, <4h 6.85V 0 – 20A 100Ah – 1000Ah	20A < 14.7V 14.7V 2.5 – 20A, <4h 13.7V 0 – 20A 100Ah – 1000Ah	10A < 29.4V 29.4V 1.4 – 10A, <4h 27.4V 0 – 00A 50Ah – 500Ah	6.7A < 44.1V 44.1V 1 – 6.7A, <4h 41.1V 0 – 6.7A 33.5Ah – 335Ah	5A < 58.8V 58.8V 0.7 – 5A <4h 54.8V 0 – 5A 25Ah – 250Ah
<b>2944</b> <b>2945</b>	220-240Vac 50-60Hz	Yellow CC ch.: Flash Yellow CV ch.: Green Float ch.: Rec. batt. capacity:	20A < 7.35V 7.35V 2.5 – 20A, <4h 6.85V 0 – 20A 100Ah – 1000Ah	20A < 14.7V 14.7V 2.5 – 20A, <4h 13.7V 0 – 20A 100Ah – 1000Ah	10A < 29.4V 29.4V 1.4 – 10A, <4h 27.4V 0 – 10A 50Ah – 500Ah	6.7A < 44.1V 44.1V 1 – 6.7A, <4h 41.1V 0 – 6.7A 33.5Ah – 335Ah	5A < 58.8V 58.8V 0.7 – 5A <4h 54.8V 0 – 5A 25Ah – 250Ah
<b>2841</b> per channel	220-240Vac 50-60Hz	Yellow CC ch.: Flash Yellow CV ch.: Green Float ch.: Rec. batt. capacity:	5A < 7.35V 7.35V 1.5 – 5A, <4h 6.85V 0 – 5A 25Ah – 250Ah	5A < 14.7V 14.7V 1.5 – 5A, <4h 13.7V 0 – 5A 25Ah – 250Ah	2.5A < 29.4V 29.4V 0.6 – 2.5A, <4h 27.6V 0 – 2.5A 12.5Ah – 125Ah	1.7A < 44.1V 44.1V 0.4 – 1.7A, <4h 41.1V 0 – 1.6A 8.5Ah – 85Ah	1.2A < 58.8V 58.8V 0.3 – 1.2A <4h 54.8V 0 – 1.2A 6Ah – 60Ah
<b>2245</b>	220-240Vac (115Vac) 50-60Hz	Yellow CC ch.: Flash Yellow CV ch.: Green Float ch.: Rec. batt. capacity:	40A < 7.35V 7.35V 5 – 40A, <4h 6.85V 0 – 40A 200Ah – 2000Ah	40A < 14.7V 14.7V 5 – 40A, <4h 13.7V 0-40A 200Ah – 2000Ah	20A < 29.4V 29.4V 2.5 – 20A, <4h 27.4V 0-20A 100Ah – 1000Ah	N.A.	N.A.
<b>2440</b>	100-240Vac 50-60Hz	Yellow CC ch.: Flash Yellow CV ch.: Green Float ch.: Rec. batt. capacity:	4.5A < 7.35V 7.35V 1.2 – 4.5A <4h 6.85V 0 – 4.5A 22.5Ah – 225Ah	4A < 14.7V 14.7V 1.2 – 4A, <4h 13.7V 0 – 4A 20Ah – 200Ah	2.5A < 29.4V 29.4V 0.6 – 2.5A, <4h 27.6V 0 – 2.5A 12.5Ah – 125Ah	1.6A < 44.1V 44.1V 0.4 – 1.6A, <4h 41.1V 0 – 1.6A 8Ah – 80Ah	1.2A < 58.8V 58.8V 0.3 – 1.2A <4h 54.8V 0 – 1.2A 6Ah – 60Ah