

M
E
B
E
M
S
G



OWNER'S MANUAL

OCEANREEF[®]
connecting divers

Warnings.....	4
Introduction.....	5
Attaching the CUBE ³ to a full face mask.....	7
Installing the microphone.....	8
Procedure for the assembling of a PTT & D-mic microphone.....	9
Installing the battery.....	9
Checking before use.....	11
Functioning of the GSM CUBE ³ with the ALPHA-PRO X-DIVERS.....	12
Functioning of the GSM CUBE ³ with the VHF system.....	13
Instructions for underwater communication.....	14
Precautions.....	15
Warranty.....	17
Troubleshooting.....	18

WARNINGS, CAUTIONS, NOTES

Pay special attention when accompanied by these symbols:



A **WARNING** indicates a procedure or situation that, if not avoided, could result in serious injury or death to the user.



A **CAUTION** indicates any situation or technique that could cause damage to the product, and could subsequently result in injury to the user.



A **NOTE** is used to emphasize important points, tips, and reminders.

WARNING



Continue to breathe while surfacing from a dive even if you are listening to the communications unit. Lung expansion injuries may result if you ascend while holding your breath. **DO NOT STOP BREATHING WHILE SURFACING FROM A DIVE.**

If you are going to speak while diving you should take in a larger than normal breath. **ALWAYS MONITOR YOUR PRESSURE GAUGE.**

Before attempting to use this device in open water you must practice using the unit in confined water (such as a pool).

INTRODUCTION

The GSM CUBE³ is an underwater communication unit capable of operating wireless, hardwired or interfaced with a VHF radio. Three units in one!

If the unit is connected to the ALPHA PRO X-DIVERS surface unit via cable, then communication is on full duplex with the surface unit (no need to press the transceiver button to communicate). At the same time the unit is capable of communicating with other wireless underwater units such as the OCEAN REEF GSM, GSM DC, GSM G POWER, GSM G POWER SL, M105 and M100. By pressing the button of the PTT the unit is transmitting on channel 1 of ultrasonic frequency (channel 1 - 31.768 kHz).

The GSM CUBE³ can be connected to a VHF radio (see page 13) through the waterproof carrying bag and other relevant connectors and interfaces.

The GSM CUBE³ is equipped with a special plug for the six pin connector which can be used when the cable is not connected. You can also connect and disconnect the unit to/from the cable while diving.

GSM CUBE³ PARTS

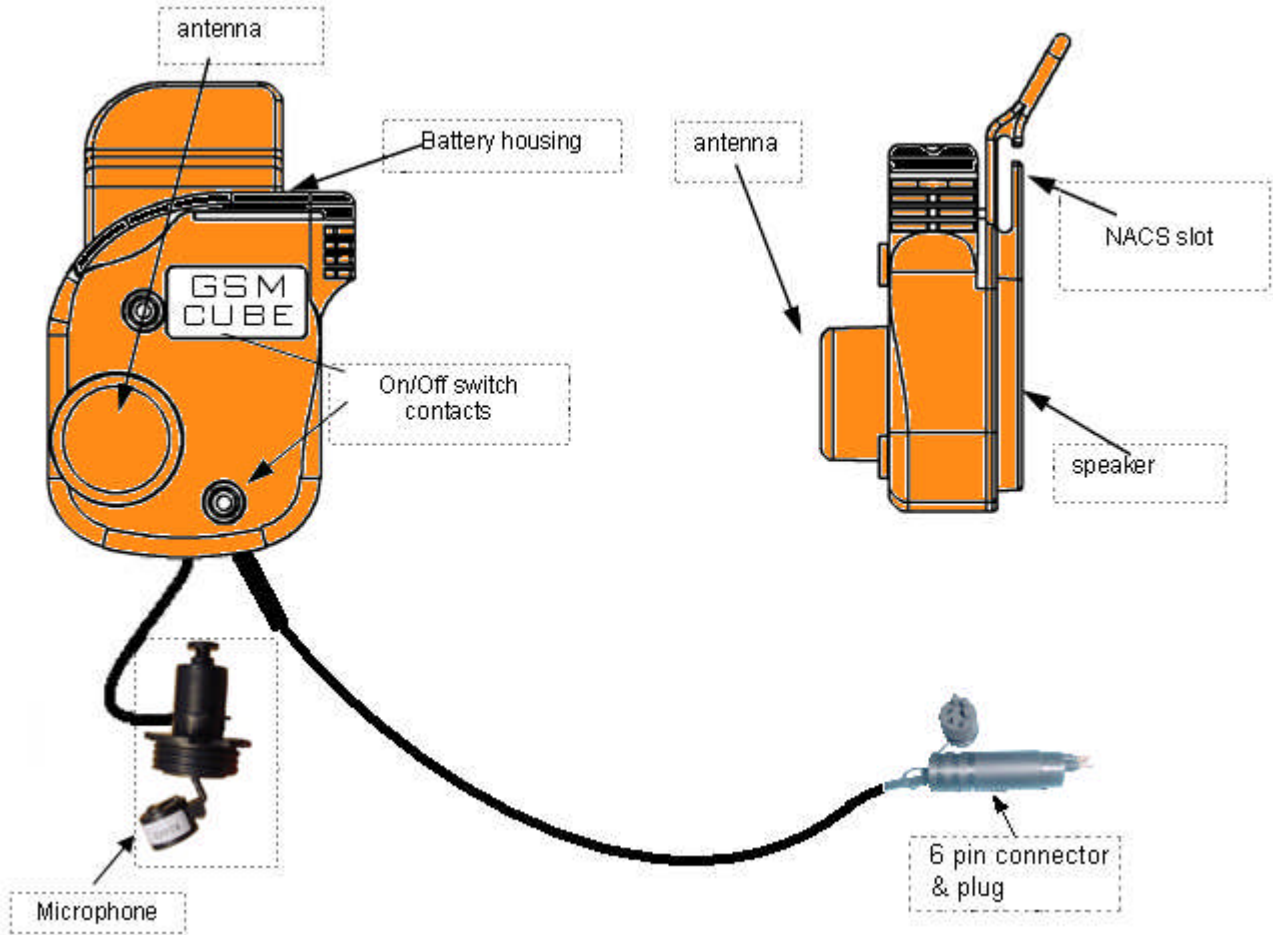

Attaching the CUBE³ to a full face mask

The CUBE³ can be attached to any full-face mask equipped with a female DIN connection for the transmission and microphone button and two quick connections. For optimum functioning we recommend using the unit on OCEAN REEF Space masks, as the unit's acoustic characteristics are designed to suit these masks.

How to install the NACS[™] (neptune adjustable communication support)

Hold the NACS[™] as pictured with the transparent stationary part to the left and the black rotating part to the right.

Remove the o-ring from the notch at the end of the black rotating part of the NACS[™] (see drawing).

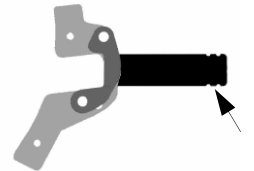

Slide the CUBE³ onto the NACS[™]

Replace the o-ring on the notch at the end of the black rotating support. The left middle strap (of the octopus strap) must be positioned over the rotating support.



Attach the NACS[™] to the mask by positioning the holes of the transparent part over the black buttons of the clamping band and pressing. These buttons are the same ones that hold the protective shield when the mask is not in use. Make sure the protective shield is removed prior to attaching the NACS[™] to the mask.

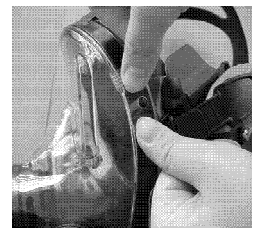

The black rotating part of the NACS[™] has a vertical rotation angle of 25°. After wearing the mask you will find the most comfortable angle for you. If you prefer to move the CUBE³ closer or farther away from your face, simply slide the CUBE³ over to the selected position and move the o-ring to a different notch.

The use of the NACS[™] allows for a more comfortable wearing of the mask and best strap adjustment.

The CUBE³ must always be used with the NACS.

NACS[™] is a patented product of OCEAN REEF.

Installing the microphone

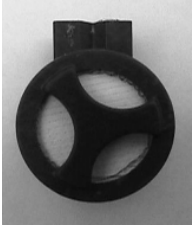

The CUBE³ uses a dynamic microphone, "**D-Mic**" encapsulated and protected by a hydrophobic membrane.

The microphone allows dependable clear reproduction of the human voice. It removes unnecessary noise such as the noise of bubbles being exhaled from the mask.

The D-Mic uses a hydrophobic membrane that allows air to pass through while protecting the microphone from water. This membrane also reduces the "muffling" effect allowing a phonic performance that is very high.

Another characteristic of the hydrophobic membrane is its mechanical strength. The D-Mic, shown in figure 4, is fitted with a membrane that is designed to handle pressure of more than 14.7 PSI. If the membrane ruptures, the microphone will flood causing transmission to cease. Remember, the Neptune masks are designed to operate under "balanced" pressure. If the mask is removed underwater the microphone WILL NOT suffer any damage. However, continuing to dive WITHOUT the mask sealed on the face the microphone may be damaged if the limits, indicated above, are exceeded in relation to the depth at which the mask was removed. Ascending must be done in accordance with the dive tables or dive computer to avoid decompression problems. The communicator and microphone should be rinsed with fresh water (immersed, not a strong "jet" of water) after each dive and should be placed in a well ventilated area that is not exposed to direct sunlight to dry.

Procedure for assembling the PTT & D-mic

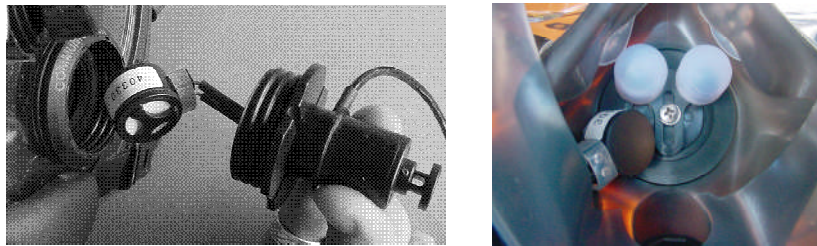

- Unscrew the communication port plug (labelled COMMUNICATION), insert the PTT & microphone through the mask into the “communication” port with the hydrophobic membrane facing the visor.
- If the membrane is turned the wrong way, facing the mouth, phonic performance will be diminished. Check that the microphone is in the position shown in pictures. Move the microphone so that it does not interfere with the diver’s lips or the pressure compensation bracket.

Installing the battery

GSM CUBE³ (when used via wireless) works with a conventional 9V alkaline battery.

Do not use manganese batteries.

- (1) Unscrew the two screws on the cover and remove the cover and cap with its O-ring.
- (2) Remove the dead battery from the main compartment.
- (3) Install a new battery in the compartment, making sure that the polarity is correct (see label on the inside).
- (4) Clean and lubricate the O-ring. Reposition the cap. The cap **MUST** face the right direction. The flat side of the battery cap must be on the front side in order to get a good seal.



When the battery has been installed, check that the battery housing and O-ring are clean. The O-ring must always be lubricated with a thin layer of silicone lubricant.

(5) Holding the cap in position, position the cover and screw the two screws in place until they are tight. Do not over-tighten the screws!

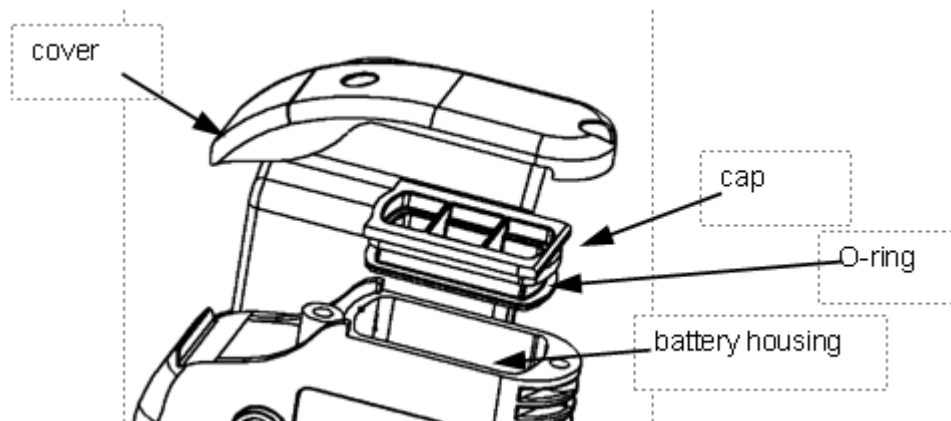

A screwdriver for GSM CUBE³ assembling/disassembling is provided in the com unit package.



If the CUBE³ is not going to be used for a while, the battery should be removed. The cap must be stored in the battery compartment. This will ensure that the unit will work properly for a longer period of time.

Checking before use

Once the battery has been installed and you have checked that the cap and cover have been closed properly, dampen your fingers and touch the two screws (On/Off switch contacts) and activate the polarity circuit. You will hear a “beep” indicating activation.



If you hear a repeated “beep”, about every 30 seconds, this means that the battery is running low. Change it.

Run another finger along the antenna. You will hear a “zzzzzz” type sound coming from the speaker. Try to bring the antenna transducer near the antenna on a Digital M105 unit, or the antenna on a GSM unit (about 5 cm / 2 inches), keeping your fingers on the On/Off contacts. You should also be able to hear the communication when the unit is not immersed in water.

Begin speaking while holding the button down. Any units near your CUBE³ should pick up your voice.

Put on a full-face mask so that it seals properly.

Check that there are no leaks between the edges and your face.

The CUBE³ speaker should be very close to your ear. Check that the reception device is not too far from your ear.



Check that the microphone is installed correctly, following the instructions above. Handle the microphone carefully.

Functioning of the GSM CUBE³ with the ALPHA-PRO X-DIVERS

The GSM CUBE³ is made to allow the connection to the ALPHA-PRO X-DIVERS.

You can connect the CUBE³ to the cable outside or inside the water; simply take away the plug from the 6 pin connector and plug it into the ALPHA-PRO X-DIVERS cable.

If you are using the unit via wireless, your communication will continue to function and you will be able to communicate via cable too.

Keeping the PTT button pressed you will be able to speak wireless and via cable at the same time, without pressing the PTT button you will talk only to the surface via cable.

Receiving mode will always be simultaneous.

If the battery of your CUBE³ has run down (or you are not using the battery) you will still be able to communicate via cable.

On the ALPHA-PRO X-DIVER surface unit the recall light will turn on as soon as the battery no longer functions!



Functioning of the GSM CUBE³ with the VHF system

The GSM CUBE³ can also become a GSM-VHF by interfacing it with the appropriate VHF interface and radio.



The GSM VHF is a very unique communication system with the integration of Ultrasonic / Underwater communication features and the VHF long distance communication requirements. It is mainly dedicated to Rescue Team Divers and was developed thanks to the collaboration with the Italian Red Cross.

The unit is comprised of a complete GSM standard hardwired to a specially modified waterproof radio carrying bag in which a number of different models of VHF radios may be inserted and interfaced. It is necessary to specify the kind of radio used and OCEAN REEF will customize the required interface cabling.

For more information about the GSM-VHF please refer to the GSM-VHF manual.

Instructions for underwater communication

- When speaking to other divers, remember that they are diving. It is best to attract their attention before sending a message.
- Talking and listening while underwater requires practice. With experience, divers will become more proficient in the use of the communications system.
- Speak slowly, and pronounce each word clearly. Only speak after having sent a call impulse by pressing the button on the microphone. It is advisable to practice in a swimming pool before using the device in open water.
- Bubbles, and especially, small air bubbles, that are in contact with or near those communicating reduce the transmitting power. When using the unit in swimming pools or in highly oxygenated water, coat your antenna with silicone lubricant. This will make it more difficult for the air bubbles to adhere to it.
- Obstacles such as rocks may reduce your communication range.
- When exhaling, reduce the emission of bubbles as far as possible (WITHOUT STOPPING EXHALING WHEN SURFACING). Bubbles cause noise or ultrasonic base signals.
- It is normal to receive a background signal like clutter. Movement of sand and pebbles on the seabed, marine motors, cetaceans, and other sources can create vibrations in the water that give rise to a range of ultrasonic waves that can be picked up by the GSM.
- When using the device in shallow water, you may experience difficulty communicating because:
 - (1) The surface is full of air bubbles formed by the waves.
 - (2) The sand under water is causing ultrasonic noise due to the waves.

PRECAUTIONS

- Do not use solvents (such as diluents) to clean the unit. They can cause irreparable damage. Only use neutral detergents. Use running water to remove the seawater from your GSM CUBE³ after use. The system must be kept completely dry and in good condition.

- Do not twist the microphone cable.
- Do not expose the unit to direct sunlight.
- Do not leave the unit in your car.
- Do not keep the unit in places that are too hot or too cold, such as near air conditioners.
- Do not keep the unit near magnetic fields.
- Do not allow it to fall or be knocked around.
- Replace the battery when it is running low. When not using the unit for extended periods of time, remove the battery from its housing to prevent damage.
- Only use 9V alkaline batteries. Install them in the battery housing, ensuring that they are of the correct charge and polarity. Do not activate the polarity circuit using metal wires or pieces of metal.
- Make sure there is no dirt, debris or water in any part of the unit, especially in the battery housing or under the O-ring. If any dirt, debris or water is found, remove it.
- When replacing the battery check the O-ring for damage. If it is damaged, replace it. The O-ring must be lubricated with a thin layer of silicone lubricant.
- Do not dismantle or repair this unit by yourself.
- Follow the instructions for correct maintenance of the microphone and battery housing, given in previous chapters.
- If the battery compartment should be flooded, remove the battery, rinse the compartment with fresh water and leave to dry. Remove any debris, and clean the spring contacts, then install a new battery. If the unit does not function, check the state of the microphone.

- Routinely clean the microphone contacts and check the integrity of the hydrophobic membrane and the case. If the microphone is flooded, it CANNOT be recovered and must be replaced.
- Do not touch the hydrophobic membrane with any sharp objects that may damage it.

Warranty

(1) OCEAN REEF communication units are guaranteed to be free of material or manufacturing defects for a period of 24 months from the time the unit is purchased. For the duration of the guarantee, the Company's responsibility is limited to replacement of any parts that are defective in our opinion, and that have not been used incorrectly or handled negligently. The unit must be returned to the outlet from which it was bought, along with the warranty card. The cost of transport is to be prepaid by the customer.

(2) Even during the guarantee period, this guarantee shall not be valid where:

- Damage was caused by incorrect handling or carelessness.
- Damage was caused by the unit falling after it was purchased.
- Damage caused by fire, earthquake, floods, lightning, or other natural disasters, pollution or electrical charges.
- The warranty card is not produced.
- Warranty not registered

(3) Additional warranty cards cannot be issued. Keep your certificate in a safe place where it cannot be lost.

TROUBLESHOOTING

Problem	Possible cause	action
The unit does not switch on (it still works via cable)	The battery is missing, the contacts are isolated, the battery is dead	Insert a charged battery. Remove isolation caps
	The polarity is inverted.	Insert the battery correctly
	The contacts are broken	Send for servicing.
	Battery compartment flooded	Remove water, rinse with fresh water, leave to dry. Lubricate the O-ring. Clean Contacts. Insert new battery.
Battery compartment flooded	O-ring dirty, incorrectly positioned or broken	Clean the O-ring, lubricate With silicone lubricant. If broken, replace. Proceed as per previous point
	Cap broken	Replace the cap.
	Seating for cover screws broken	Send for servicing
The unit switches on and receives but does not transmit both ways.	Microphone flooded or defective	Change the microphone
	Microphone contacts disconnected or dirty	Clean the contacts with fresh water
	Cable between microphone and casing broken	Send for servicing

The unit does not receive via wireless.	The transmission unit is not working	Try another transmission unit
	Speaker or internal components defective	Send for servicing
The unit does not receive via cable	Broken cable	Send for servicing
	Surface unit out of power	Recharge surface unit
The unit transmits continually via wireless	Call button defective	Send for servicing



MESTEL SAFETY S.r.l.
Via Arvigo 2, 16010 Genova (Italia)
Phone +39 010 6598 611 Fax +39 010 6598 622
e-mail ocean.reef@oceanreefgroup.com

OCEAN REEF, Inc.
1699 La Costa Meadows Dr. Suite 101 San Marcos, CA 92078
Phone +1 760 744 9430 Fax +1 760 744 9525

OCEAN REEF on the Internet
<http://www.oceanreefgroup.com>

© OCEAN REEF 2008