



**Miniature Ionization Vacuum Gauge
IGM-401 Module
*The "Hornet"***



User's Manual

May 2007

Rev. 1.06

1475 S. Fordham St.

Longmont, CO 80503

Phone 303-651-0551

Fax 303-678-1754

E-mail info@instrutechinc.com

Table of Contents

Introduction / General Information	Page
Description	3
Specifications	3
Safety	
General	4
Service and Operation	4
Electrical	5
Overpressure	6
Installation	
Mechanical	6
Position	6
Vibration	6
Dimensions	7
Electrical	8
Analog Connector & Pinouts	9
RS485 Connector & Pinouts	10
Setup & Operation	
Turning on Power to IGM	11
Gas Sensitivity Correction Factor	11
Emission Current	12
Overpressure Shut down	12
Degas	12
Bakeout	14
Analog Output	15
Activating the IGM	16
User Interface	
User Interface Basics	17
Factory-set Default Parameters	18
Menu Item Explanations	19
SETUP DISP	19
SETUP UNIT	20
SETUP IG	21
SETUP COMMS	22
SERVICE MENU	22
RS485 Interface	
RS485 Commands	23
Service & Maintenance	
Calibration	26
Troubleshooting	26
Sensor Replacement	27
Factory Service and Support	28
Warranty	28
Trademarks & Acknowledgements	28

Introduction / General Information

Description

The InstruTech IGM-401 module provides the basic signal conditioning required to turn a Ionization vacuum gauge into a complete measuring instrument. The module provides a log-linear analog output, RS485 interface, and one setpoint relay. In addition, a built-in display provides a convenient user interface for setup and operation of the vacuum gauge.

Specifications

measurement range (signal)	1×10^{-9} to 5×10^{-2} Torr / 1.3×10^{-9} to 6.7×10^{-2} mbar / 1.3×10^{-7} to 6.7 Pa
display	OLED Graphical Display, 3 digits plus 2 digits exponent, bright yellow
materials exposed to gases	Dual Filaments: Yttria Coated Iridium Ion Collector: Tungsten Grid: Tantalum Enclosure: 316/304 stainless steel
sensitivity	Factory pre-set. Also user adjustable between 2 to 99 using the display
X ray limit	$< 5 \times 10^{-10}$
emission current	0.1, 4 mA
degas	4 Watts e-beam
overpressure protection	Gauge turns off at factory default setting of 5×10^{-2} Torr
internal gauge volume	1.0 in^3 (16.4 cm^3)
operating temperature	0 to + 40° C
bakeout temperature	200° C (sensor only - electronics removed)
humidity	0 to 95% RH non-condensing
weight	0.6 Lbs (0.27 kg) with NW25 KF flange
mounting Orientation	Any
digital Interface	RS-485
output signals	
analog Output	Log-linear 0 to 9 Vdc, 1V/decade
filament & Degas	Degas & Filament on/off status are determined by an open collector transistor or via RS-485 digital communications protocol
setpoint relay	Single-pole, double-throw (SPDT), 1A at 30 Vdc resistive, or ac non-inductive
adjustment	Adjust value using the front panel push buttons or RS-485 commands
input signal	Degas and Filament on/off & emission current are set by continuity to ground using digital inputs, via RS-485 commands or by using the front panel push buttons
filament selection	User selectable between filament 1 or 2 using the front panel push buttons or via RS-485 commands
Connector	9-pin D

Safety

Instrutech has designed and tested this product to provide safe and reliable service, provided it is installed and operated within the *strict safety guidelines provided in this manual*. **Please read and follow all warnings and instructions. Failure to comply with these safety procedures may result in serious bodily harm, including death, and/or property damage.** Failure to comply with these warnings violates the safety standards of the installation and intended use of the instrument. Instrutech, Inc. disclaims all liability for the customer's failure to comply with these requirements.

Although every attempt has been made to consider most possible installations, Instrutech cannot anticipate every contingency that arises from various installations, operation, or maintenance of the module. If you have any questions about the safe installation and use of this product, please contact Instrutech at the address shown on page 1 of this manual.

Service and Operation

Do not modify this product or substitute any parts without authorization from a qualified InstruTech technician.

Return the product to an Instrutech qualified service and repair center to ensure that all safety features are maintained. Do not use this product if unauthorized modifications have been made.

Do not use this device in an explosive atmosphere or in the presence of flammable gases or fumes.

Do not use this device to measure the pressure of explosive or combustible gases or mixtures. The sensor filaments operate at incandescent temperatures and could become an ignition source.

InstruTech gauges and modules are calibrated for Nitrogen. See page 8 for explanation.

Ensure the IGM is properly connected to earth ground.

Do not turn on Filaments when pressure exceeds 1.30×10^{-3} Torr at 4ma emission current.

Do not turn on Filaments when pressure exceeds 5.0×10^{-2} Torr at 0.1 ma (100uA) emission current.

Ensure vacuum level is at or less than 5.0×10^{-5} Torr before attempting to initiate Degas.

Use the appropriate power source of 20 to 28 Vdc, at 14 W

Turn off power to the IGM before attempting to service the module. Do not touch any of the gauge tube pins when under vacuum

Turn off power to the IGM before detaching the electronics from the sensor for sensor replacement or bakeout purposes.

Turn off power to the IGM if a cable or plug is damaged or the product is not operating normally according to this instruction manual. Contact a qualified InstruTech technician for any service or troubleshooting condition that may not be covered by this instruction manual.

Do not use if IGM has been dropped or the enclosure has been damaged. Contact a qualified InstruTech technician for possible return to InstruTech for evaluation.

It is highly recommended to periodically alternate operating Filaments 1 and 2. An inactive Filament not operating for an extended length of time can cause failure of that Filament. This will be more problematic in dirty applications.

After servicing this product, ensure that all safety checks are made by a qualified service person.

Replacement Parts: When replacement parts are required, ensure that the parts are specified by Instrutech Inc. Unauthorized substitutions or non-qualified parts may result in fire, electric shock, or other hazards, and will void the warranty.

To reduce the risk of fire or electric shock, do not expose this product to rain or moisture. This product is not waterproof and careful attention must be paid to not spill any type of liquid onto this product.

Due to the possibility of corrosion under certain environmental conditions, it is possible that the product's safety could be compromised over time. It is important that the product be periodically inspected for sound electrical connections and grounding. Do not use if the grounding or electrical insulation has been compromised.

The most common cause of all vacuum gauge failures is contamination of the sensor. Noisy or erratic readings and total gauge failures are all possible indications of gauge contamination. Contaminations can generally be characterized as either: A) a reaction of process gases with sensor elements, or B) an accumulation of material on the sensor elements. Sensors that fail due to contamination are not covered under warranty.

Electrical conditions

Danger: When high voltage is present in any vacuum system, a life threatening electrical shock hazard may exist unless all exposed conductors are maintained at earth ground. This applies to all products that come in contact with the gas.

Danger: An electrical discharge through a gas may couple dangerous high voltage directly to any ungrounded conductor. A person may be seriously injured or killed by coming in contact with an exposed ungrounded conductor at a high voltage potential. This applies to all products that may come in contact with the gas.

Proper Grounding: Verify that the vacuum port on which the module is mounted on is electrically grounded. This is essential for safety as well as proper operation. The gauge and/or case of the module must be connected to earth ground. Use a ground lug on the flange if necessary.

Danger: In order to protect personnel from electric shock and bodily harm, shield all conductors which are subject to potential high voltage electrical discharges in or around the vacuum system.

Danger: The power supply used in the IGM is subject to high voltages which could cause severe injury or death. In order to prevent electric shock and bodily harm, user should wait for at least 5 minutes after power is removed before touching IGM's power supply components.

Danger: When the IGM is turned on, 180 V is present at the power supply and other components such as the ion gauge and the cable. Furthermore, voltages as high as 480 V are present during Degas.

It is the user's responsibility to ensure that the electronic signals from the device (Analog, relays, etc) are used in a safe manner. Always double check the system set up before using these signals to automate your process.

Overpressure

Warning: Install suitable protective devices such as relief valves or rupture disks that will limit the level of the pressure to less than what the vacuum system can withstand.

In cases where an equipment failure could cause a hazardous situation, always implement a fail-safe operation. An example is the use of a pressure relief valve in an automatic backfill operation where a malfunction could result in high internal pressures.

The gauge should not be exposed to pressures above 1000 Torr.

Installation - Mechanical

The IGM is intended for indoor use only and it can be mounted anywhere in the system in any physical attitude. Mount the IGM as close as possible to the pressure you want to measure. Long or restricted tubing will create a pressure difference (error) between your process and the gauge, and cause a delay in response to pressure changes. Mounting the IGM too close to a gas source or pump will also cause errors in the readings.

Note. You can install the IGM in the upside-down mounting position if desired. The data can be flipped on the display screen by selecting the FLIP SCREEN option from the SETUP DISP menu discussed later in this manual.

Don't mount the IGM near a source of heating or cooling, such as heaters or air conditioning vents.

Don't mount the IGM above evaporation source, as the vapors could result in sensor contamination, measurement error or sensor failure.

Don't mount the IGM where it will be subjected to excessive vibration, such as on mechanical pumps. Vibrations may cause 'noisy' readings, and reading errors due to induced cooling of the sensor.

Shield the IGM near ion or electron sources such as an electron beam or in a sputtering system. Don't mount the IGM near strong magnetic fields. These conditions can result in measurement error.

Fittings - follow the fitting manufacturer's recommendations and note the following:

The IGM is available with the following flanges:

- NW 16KF, NW25KF, NW40KF
- 1.33" Mini Conflat, 2.75" Conflat (rotatable)

For safety purposes the housing of the gauge must be grounded to the vacuum chamber. When using the KF flanges, metal clamps must be used to ensure proper grounding. Do not attempt to modify your flange in order to use non-metallic type of flange clamps.

Use all metal vacuum fittings when operating pressures are expected to be below 1×10^{-7} Torr (1.33×10^{-7} mbar, 1.33×10^{-5} Pascals)

IGM Dimensions

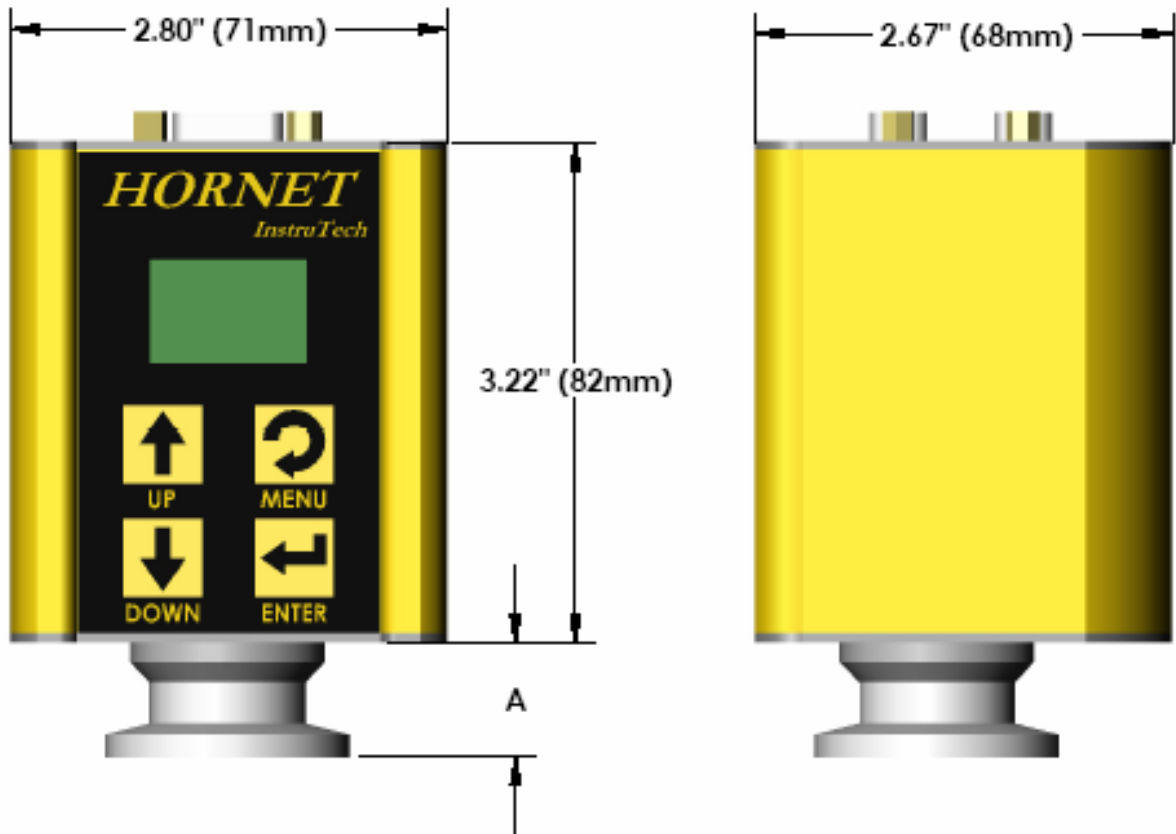

<u>Fitting</u>	<u>dimension A</u>
NW16KF	1.45" (37mm)
NW25KF	1.45" (37mm)
NW40KF	1.45" (37mm)
1-1/3" MiniConflat®	1.85" (47 mm)
2-3/4" Conflat®	1.70" (43 mm)

Figure 1 - IGM401 Dimensions

Installation – Electrical

Grounding: Be aware that some vacuum fittings, especially those with O-rings, do not produce a good electrical connection between the gauge and the chamber it is connected to. Be sure the vacuum gauge and the rest of your vacuum system are properly grounded to protect personnel from shock and injury. Good recommended practice is to remove power from any cable prior to connecting or disconnecting it.

The InstruTech IGM will directly replace most GP Micro-Ion[®] modules using existing cables and electronics. The IGM offers the user the choice to operate the unit using the Front panel push buttons, the Analog interface or an RS485 Interface. There are two 9-pin D connectors located on the IGM of which one should be used according to user's interface requirements. Selection of one interface overrides the other interface. **(See INPUT CNTL under SETUP UNIT on page 20 for more details.)**

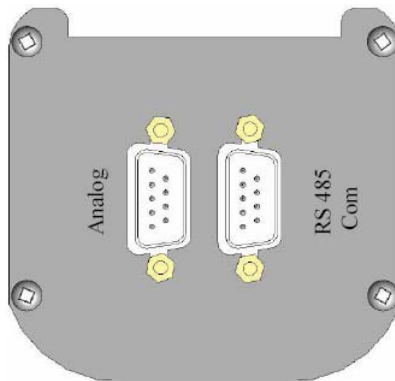

Figure 2. IGM I/O Interface

When using the InstruTech's power Supply PS501A, connect the power supply only to the Analog connector. **Do not connect the InstruTech PS501A power supply to the RS485 Com connector. Caution: Use only one InstruTech power Supply PS501A. Do not connect two Instrutech PS501A power supplies to the IGM Simultaneously. This will result in power supply and instrument damage.**

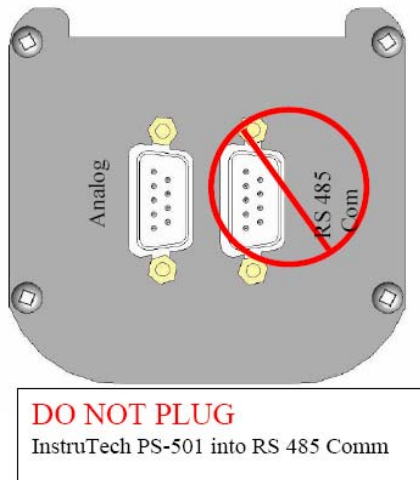

Figure 3. InstruTech Power Supply PS501A Connection

The IGM allows for operation of the unit including turning the gauge/filaments on/off, selecting emission current and turning Degas on/off using digital inputs, RS485 communication commands or the front panel push buttons.

Digital Inputs using the Analog Connector

When using the Analog I/O connector, fabricate a cable to 9-pin D connector, according to digital input signals and pin assignments as described below:

Table 1 – IGM401 I/O Analog Connector

PIN NUMBER	PIN DESCRIPTION
1	Gauge On/Off input signal. The gauge/filament is activated (Operational) by applying a continuous ground. This will activate the IGM and will turn on the Filament. The gauge is turned off by removing the ground.
2	Power ground.
3	Analog Output. (log-linear 0 to 9 Vdc, 1V/decade)
4	Power Input (20-28 Vdc at 14 Watts). Protected against power reversal, transients, and over-voltages.
5	Degas Status output signal. This is an output signal to other external instruments to confirm Degas is on or off. Signal: Open collector transistor (ground emitter) rated at 40 V max. VCE, 50 mA max. Transistor off = degas off, transistor on = degas on.
6	Degas On/Off Input signal. The Degas is initiated by applying a ground. The degas cycle will last for 2-10 minutes (based on user setting) even if ground is removed. The ground must be removed to start cycle again.
7	Analog Signal Ground. Use only as analog output ground
8	Emission Current. Applying ground changes emission current from 0.1 ma (100uA) to 4 ma.
9	Gauge Status. This is an output signal to other external instruments to confirm Gauge/Filament is on or off. Signal: Open collector transistor (ground emitter) rated at 40 V max. VCE, 50 mA max. Transistor off = Gauge off, transistor on = Gauge on.

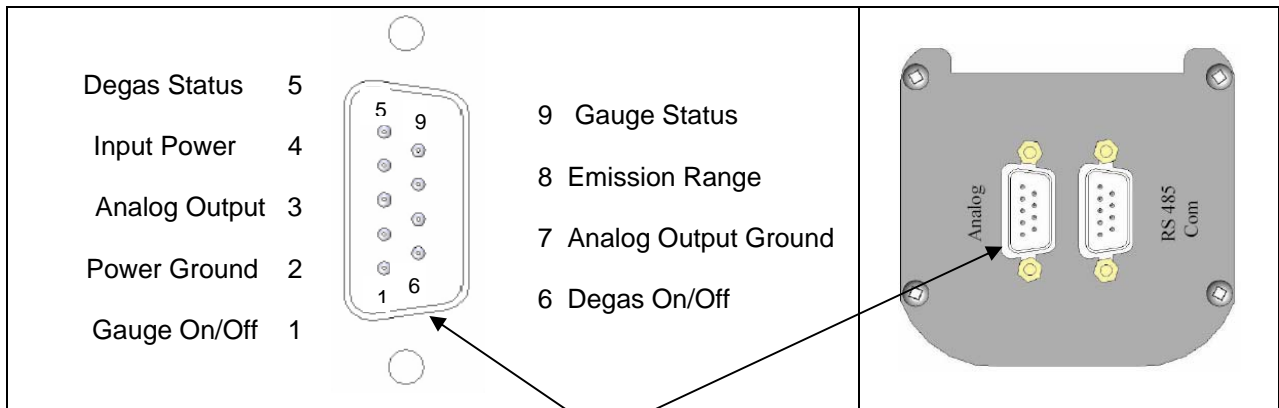

Figure 4 – IGM401 Analog 9-Pin male I/O Connector

Note: If you are replacing a GP Micro-Ion[®] module, first **determine if you are using the Analog Output or the RS485 Digital version of Micro-Ion[®] module**. Then simply plug your existing cable into **one of the two** appropriate 9-pin connectors on the end of the InstruTech module.

RS485 Interface

When using the RS-485 I/O connector, fabricate a cable to 9-pin D connector, according to signals and pin assignments as described below:

Table 2 – IGM401 RS485 I/O Connector

PIN NUMBER	PIN DESCRIPTION
1	Setpoint relay – Normally Open
2	Power Input (20-28 Vdc at 14 Watts). Protected against power reversal, transients, and over-voltages. (Caution: Do not connect InstruTech’s power supply PS501-A to the RS485 Com Connector. PS501-A must be connected to the Analog connector shown in page 9.)
3	No connection.
4	Power ground.
5	Setpoint relay – Normally Closed
6	RS-485 (-) Input.
7	Setpoint Relay – Common.
8	No connection..
9	RS-485 (+) Input.

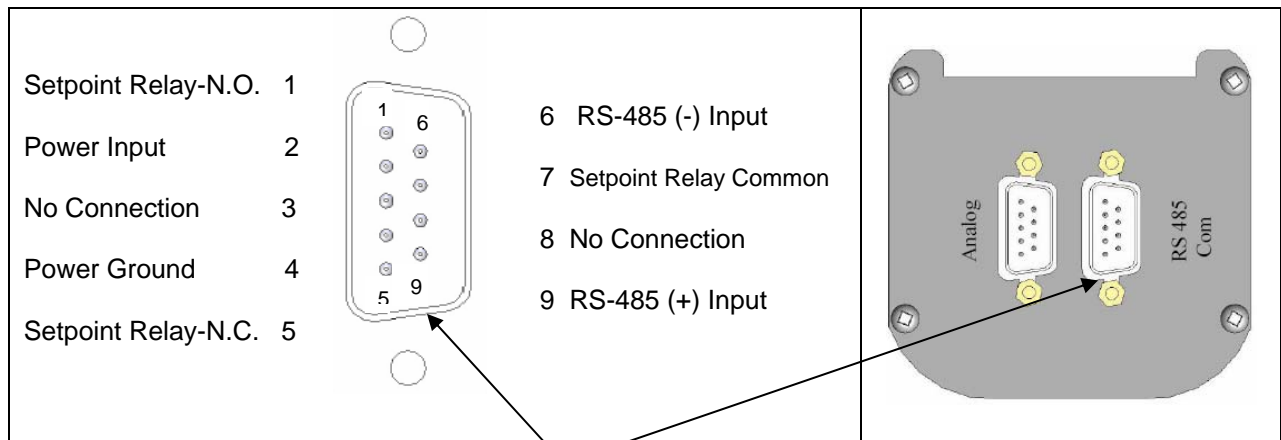

Figure 5 – IGM401 RS-485 Comm 9-Pin female I/O Connector

Note: The RS-485 version of Granville-Phillips Micro-Ion[®] is provided with a 9-pin male connector. The InstruTech’s RS-485 connector is a 9-pin female connector. If you are replacing an RS-485 version of Granville-Phillips Micro-Ion[®] and would like to use your existing cable, a 9-pin female to male gender changer is required. Please can contact InstruTech or your local connector suppliers to obtain this part.

Setup and Operation

Turning On Power to IGM

Connect power to IGM using the designated pins 4 and 2 as shown in Table 1. The display will show "Unit Status Off". This indicates the display is on but the gauge/filaments have not been activated and operational yet.

Read this instruction manual in its entirety before activating the gauge/filaments. Refer to [Activating the IGM](#) section for further instructions on activating/operating the gauge/filaments.

Gas Sensitivity Correction Factor :

InstruTech gauges and modules are calibrated for N₂.

Warning: Read the following information very carefully if you intend to use a gas other than Nitrogen or air:

The IGM offers the user the choice to use the factory default N₂ or select from a table of 16 most commonly used gases in the menu.

Using Nitrogen as the default gas

If you intend to use Nitrogen as the default gas even though the gas in use is not Nitrogen, you can select N₂ from the menu but you must manually apply a gas sensitivity correction factor to the displayed measurement and outputs. The following table provides some typical correction factors. To correct the measurements, divide the measured pressure by the correction factors:

Table 3 – Gas Sensitivity Correction Factors

Gas	Sensitivity Correction Factor	Gas	Sensitivity Correction Factor
He	0.18	H ₂ O	1.12
Ne	0.30	NO	1.16
D ₂	0.35	Ar	1.29
H ₂	0.46	CO ₂	1.42
N ₂	1.00	Kr	1.94
Air	1.00	SF ₆	2.50
O ₂	1.01	Xe	2.87
CO	1.05	Hg	3.64

Example:

A) The IGM is selected for Nitrogen. The gas in use is helium. The measured pressure is displayed at 4×10^{-7} . Then the actual pressure of Helium is $4 \times 10^{-7} / 0.18 = 2.22 \times 10^{-6}$ Torr of Helium

Selecting a specific gas other than Nitrogen

If a specific gas other than N₂ is selected from the menu, the IGM will automatically apply the conversion factor to the measurement. The specific gas symbol will also be displayed along with its measurement value. In this case no correction factor needs to be applied to IGM's measurements.

The user must ensure all operators are aware the display measurement represents the true measurement value specific to the selected gas.

Emission Current

IGM provides a choice of 4 ma or 100uA (0.1 ma) emission current. As a general rule, in clean applications and operating at higher pressure ranges (5×10^{-6} Torr to 2.5×10^{-2} Torr) the 100uA (0.1 ma) emission is preferred. At lower operating pressures (1×10^{-9} Torr to 1×10^{-4} Torr) the 4 ma emission should be used. The emission current can be selected by one of the following three methods:

- 1) Front Panel push buttons. This is achieved by first selecting Front Panel in the INPUT CNTL submenu of the SETUP UNIT menu. Then select EMISSION SELECT in the FP OPERATE submenu of the SETUP UNIT.
- 2) Digital Input. This is achieved by first selecting DIGI/RS485 in the INPUT CNTL submenu of the SETUP UNIT menu. Then applying ground to pin 8 of the Analog 9 pin D connector located at the top of the module will change emission current from 100uA (0.1 ma) to 4 ma.
- 3) By RS-485 commands. This is achieved by first selecting DIGI/RS485 in the INPUT CNTL submenu of the SETUP UNIT menu. Then sending an RS485 command to change emission current will automatically switch the module to the RS485 mode.

Note: When using diffusion pumps there is a possibility of the oil vapors entering the gauge sensor tube. This can form an insulator on the internal components of the sensor which can lead to instability in controlling the emission. In this case, the 4 ma emission current should be selected.

Overpressure shut down

The IGM is provided with factory set default values for overpressure shut down. The gauge will shut off automatically should the pressure reach or rise above the pressure shut down value. Refer to table 4 below for overpressure shut down values:

Table 4 – Factory set overpressure shut down values

Emission Current	Overpressure Shut Down (Torr)	Overpressure Shut Down (mbar)	Overpressure Shut Down (Pascals)
4 ma	1.30×10^{-3}	1.73×10^{-3}	1.73×10^{-1}
100uA (0.1 ma)	5.00×10^{-2}	6.66×10^{-2}	6.66

Degas

Degas is used to rid the gauge sensor tube of contaminants. Degas is achieved by applying Electron Bombardment (EB) to the grid. The intervals at which Degas should be applied vary for each application. The sensor's performance will normally improve after each Degas cycle.

Degas must be applied while the gauge/filament is activated and operating.
Ensure vacuum level is at or less than 5.0×10^{-5} Torr before attempting to initiate Degas.
Power during Degas is about 4 watts higher than the normal operating pressure.

Degas can be selected by one the of the following three methods:

- 1) Front Panel push buttons. This is achieved by first selecting Front Panel in the INPUT CNTL submenu of the SETUP UNIT menu. Then select DEGAS ON/OFF in the FP OPERATE submenu of the SETUP UNIT.

- 2) Digital Input. This is achieved by first selecting DIGI/RS485 in the INPUT CNTRL submenu of the SETUP UNIT menu. Then Degas can be initiated by applying a continuous ground to pin 6 of the Analog 9-Pin D connector located on the top the IGM Then sending an.
- 3) By RS-485 commands. This is achieved by first selecting DIGI/RS485 in the INPUT CNTRL submenu of the SETUP UNIT menu. Then sending an RS485 command to degas will automatically switch the module to the RS485 mode.

Degas will automatically turn off after 2 minutes when using factory default settings. The user can however reprogram the IGM for a Degas cycle to last anywhere between 2 to 10 minutes.

The IGM will continue to display the measured operating pressure while Degas is proceeding.

Degas will automatically turn off if the pressure exceeds 3.0×10^{-4} Torr during the Degas cycle.

Degas can be interrupted by turning off the Filament.

It is not recommended to run Degas for more than 30 minutes every 4 hours.

Bakeout

A chamber bake may be performed for new systems or after routine maintenance. The sensor can be baked out to 200 °C as long as the sensor fitting uses Metal O-rings. (For sensor fittings using elastomer O-rings, the maximum bakeout temperature is limited to the maximum temperature rating of the elastomer O-ring). Ensure the temperature of the sensor tube and the vacuum fitting to the sensor is at the same or above the chamber temperature. The electronic module must be removed from the sensor if the bake-out temperature is to exceed 70 °C. To bake out the sensor use the following procedure:

1. Turn off power to the IGM.
2. Disconnect the cable from the IGM.
3. Use 3/32 size Allen Wrench to remove the #4-40 socket head cap screws as shown below.
4. Detach the metal enclosure and the electronic from the sensor.
5. The black plastic cap attached to the gauge tube and the end plate does not have to be removed for Bakeout.

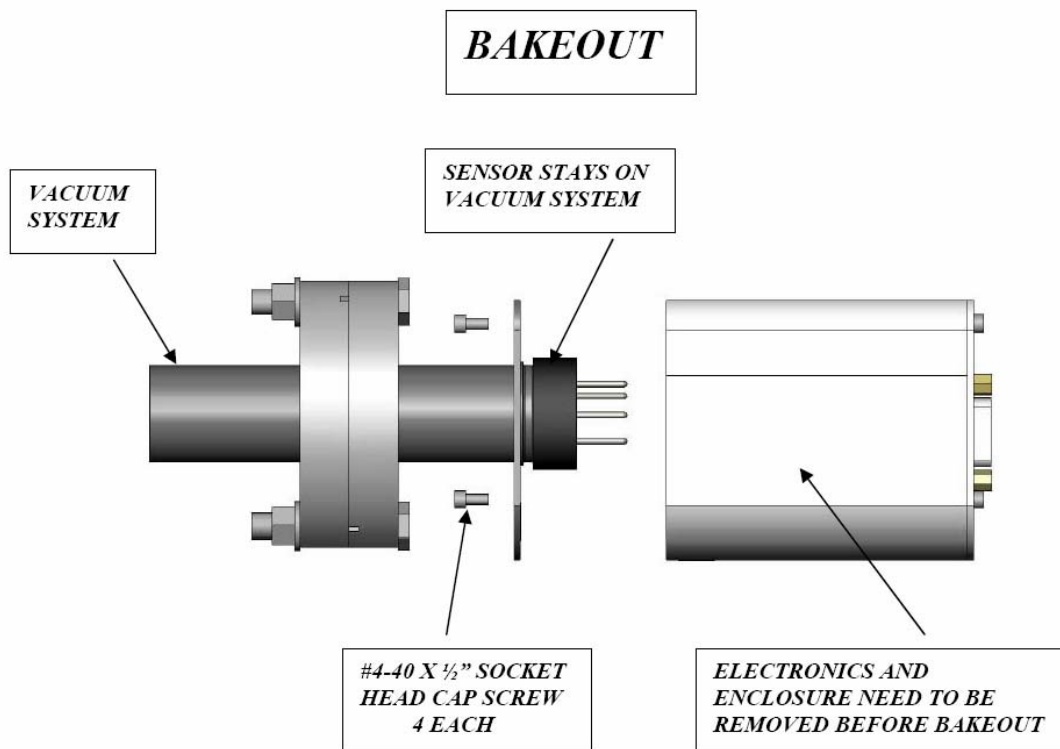

Figure 6 – Bakeout

Analog Output

The log-linear output signal and pressure are related by the following formulas:

$$P = 10^{(volts - 10)} \quad V = \log_{10}(P) + 10$$

where P is the pressure in Torr, and V is the output signal in Volts.

The output voltage is zero when pressure is at 1.0E-10.

The output voltage will switch to above +10 Vdc under the following conditions:

- 1)The gauge is turned off.
- 2)The pressure exceeds 1.30 x10⁻³ Torr at 4ma emission current.
- 3)The pressure exceeds 5.0 x10⁻² Torr at 0.1 ma (100uA) emission current.
- 4) The pressure exceeds 3.0 x10⁻⁴ Torr during Degas.

Table 5 - Log-Linear Analog Output

Pressure (Torr)	Voltage
1.0E-10	0.0
1.0E-09	1.0
1.0E-08	2.0
1.0E-07	3.0
1.0E-06	4.0
1.0E-05	5.0
1.0E-04	6.0
1.0E-03	7.0
1.0E-02	8.0
5.0E-02	8.698
Filament if off	≥10

The following chart shows the graphical results of table 5 and formulas above. Pressure is plotted on the X-axis with a log scale; the output signal is plotted on the Y-axis on a linear scale.

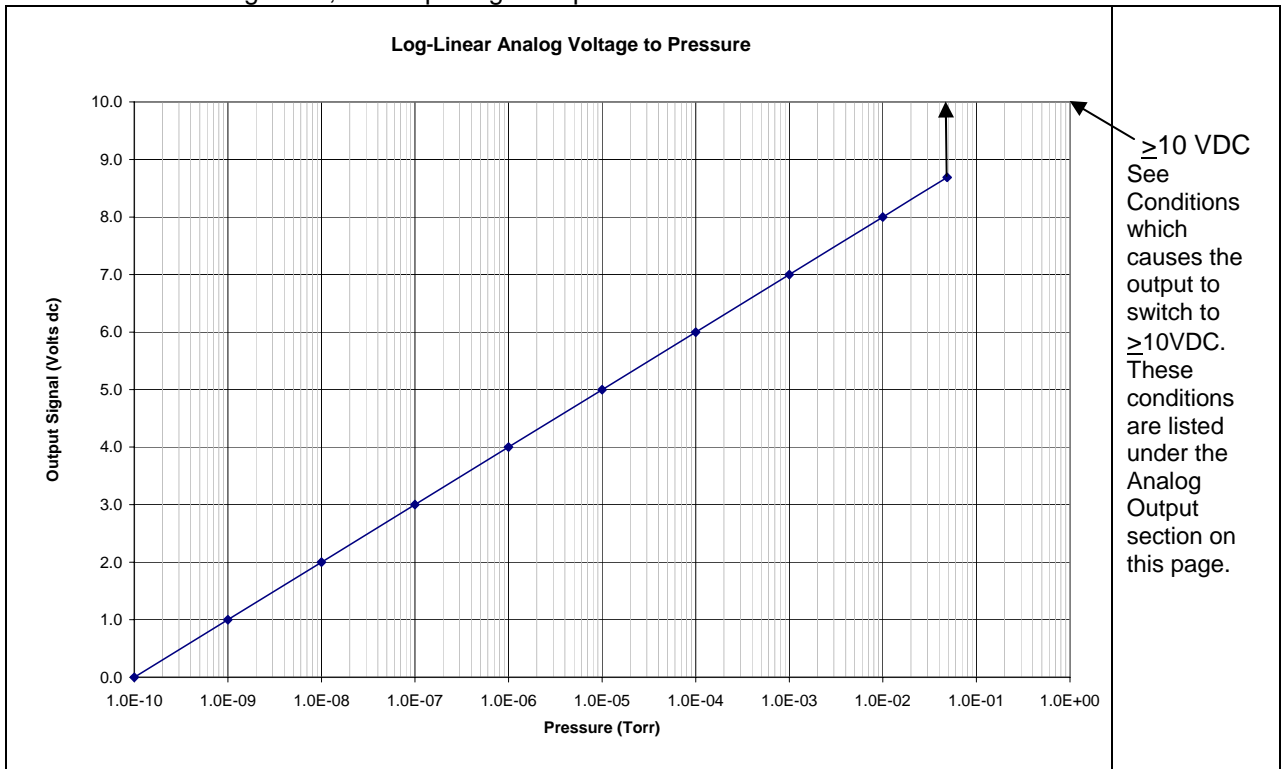

Figure 7. Plot of the formulas and data for the log-linear output signal

Activating the IGM (Turning the Filaments on)

Before you activate the gauge/filament, make sure you understand all instructions and information provided in this manual.

You can activate the IGM (gauge/filaments turned on and operating) by one of the following three methods:

- 1) Front Panel push buttons. This is achieved by first selecting Front Panel in the INPUT CNTRL submenu of the SETUP UNIT menu. Then access the UNIT ON/OFF in the FP OPERATE submenu of the SETUP UNIT and select On to turn the gauge/filament on.
- 2) Digital Input. This is achieved by first selecting DIGI/RS485 in the INPUT CNTRL submenu of the SETUP UNIT menu. Then apply a continuous ground to pin 1 of the Analog 9-Pin D connector located on the top the module.
- 3) By RS-485 commands. This is achieved by first selecting DIGI/RS485 in the INPUT CNTRL submenu of the SETUP UNIT menu. Then sending an RS485 command to turn filament on will automatically switch the module to the RS485 mode.

Initiating filament to turn on will result in only one attempt to activate the gauge/filament operational. If this is unsuccessful, the input must be reset back to off before another attempt is made to turn it on again. See messages on display for possible causes. If the problem persists consider the following possible causes:

- Insufficient power if ITI's power supply is not used.
- System pressure exceeding the overpressure shut down limit or pressure is at a value at which the emission can not be achieved.
- Contamination.
- See messages on display for other possible causes.

Note: The filament/gauge is turned off by one of the following three methods:

- 1) Front Panel push buttons. If this mode was selected previously for operating the module, then simply turn off the gauge/filament by accessing the UNIT ON/OFF in the FP OPERATE submenu of the SETUP UNIT.
- 2) Digital Input. If this mode was selected previously for operating the module, then turn off the gauge/filament by removing the ground from pin 1 of the Analog 9-Pin D connector,
- 3) By RS-485 commands. If this mode was selected previously for operating the module, then initiate send RS0485 command to turn off filament.

User Interface

The menus within the IGM user interface have been designed for easy operation and a natural progression of setup parameters. The following sections give a brief explanation of the features for added clarity.

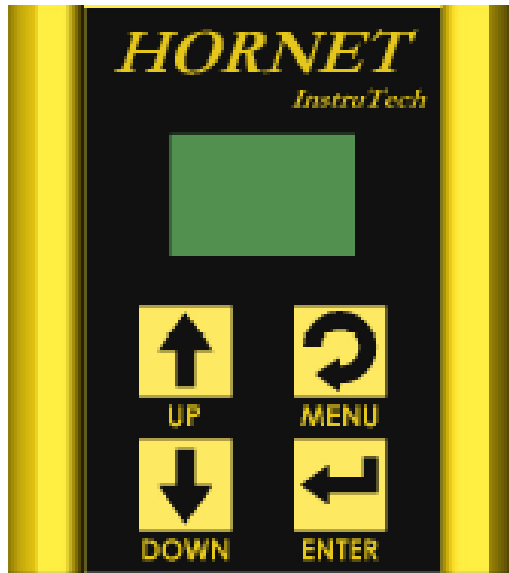

Figure 8 – IGM401 Interface

The four buttons below the display are the programming buttons. During programming of the IGM, the display will identify what function each button represents.

To begin programming, press the MENU key. Press the Enter key to access the parameters and save the new settings. Press the UP and DOWN key to select the desired menu and change the parameters. Press the MENU Key to return to the previous menu or press repeatedly to return to the main screen. To continue setting additional parameters, scroll with the UP and DOWN keys until you reach the desired parameter.

Factory-Set Default Parameters

The following is a summary of all factory-set default values in IGM's display menu.

SETUP DISP

- CONTRAST [Factory default = 51]
- MODE [Factory default = *NORMAL*]
- FLIP SCREEN [Factory default = *NORMAL*]

SETUP UNIT

- UNITS [Factory default = *TORR*]
- DEFAULTS [Factory default = *MENU TO EXIT*]
- GAS TYPE [Factory default = *N2*]
- INPUT CNTL [Factory default = *DIGI/RS485*, (Factory default is Digital Input)]
- FP OPERATE {Appears only when FRONT PANEL is selected in INPUT CNTL above.)
 - UNIT ON/OFF*: [Factory default = *OFF*]
 - EMISSION SEL*: [Factory default = *100UA*]
 - DEGAS ON/OFF*: [Factory default = *OFF*]

SETUP IG

- DEGAS TIME [Factory default = 2]
- OVER PRES 4 [Factory default = *1.30E-03 TORR*]
- OVER PRESS 100 [Factory default = *5.00E-02 TORR*]
- SENSITIVITY [Factory default = *Actual Sensor sensitivity (nominal = 8-12)*]
- FILAMENT NUM [Factory default = *FILAMENT 1*]
- RLY1 LO TRIP [Factory default = *1.00E-06 TORR*]
- RLY1 HI TRIP [Factory default = *5.00E-06 TORR*]
- RELAY 1 TEST [Factory default = *OFF*]
- VENT DETECT Factory default = *ON*
- FIL USAGE [Factory default = *all at 0M (zero minutes)*]

SETUP COMMS

- BAUD RATE [Factory default = *19200,8,N,1*]
- ADDR [Factory default = *1*]
- ADDER OFFSET [Factory default = *0*]

SERVICE MENU

- INFO [Factory default = *FIRMWARE VERSION*]
- OP TIME [Factory default = *TOTAL TIME OPERATIONAL <MINUTES> 0*]

Note:

The above correspond to the GP Micro-Ion[®] modules factory setting. If you are replacing a GP Micro-Ion[®] module you do not need to change any of the parameters programmed in the factory. If you wish to make any changes refer to the next section for menu item explanations.

Menu Item Explanations

SETUP DISP

- SET CONTRAST: [Factory default = 51]

This function sets the display contrast. Use the ENTER KEY to access the CONTRAST menu and use the UP and DOWN Keys to select a number between 1 and 120. The contrast setting of 120 provides the highest contrast (brightest) and 1 the lowest. Select the ENTER KEY again to save the value selected. (Note: Factory default setting optimizes display life.)

- MODE: [Factory default = NORMAL]

Use the ENTER KEY to access the MODE menu and use the UP and DOWN Keys to select a NORMAL or a RESEARCH mode. Select the ENTER KEY again to save the desired mode.

Normal:

This mode displays the most commonly used variables. These are the measured pressure, the pressure unit, the gas symbol, and filament and relay status. All these variables will be displayed on the main screen simultaneously. In the following example, the measure pressure is 6.45×10^{-9} Torr, Filament #1 is on, gas is Nitrogen and Relay #1 is on.

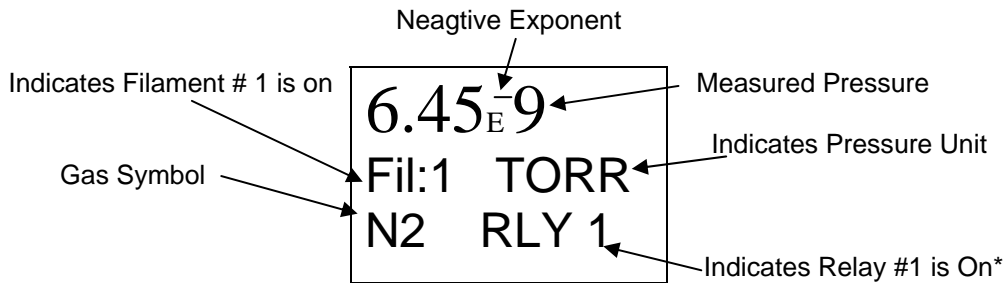

***Note: "RLY 1" disappears from the screen in its entirety when relay is turned off.**

RESEARCH:

This mode displays the measured pressure, emission current, ion current, filament Voltage and filament current. In the following example, the measure pressure is 1.00×10^{-9} Torr, (Pressure unit is based on selected units in SETUP UNIT menu). Emission current is 4.00×10^{-3} amps, Ion current is 4.00×10^{-11} amps, Filament Voltage is 1.5 Vdc and Filament current is 1.9 amps.

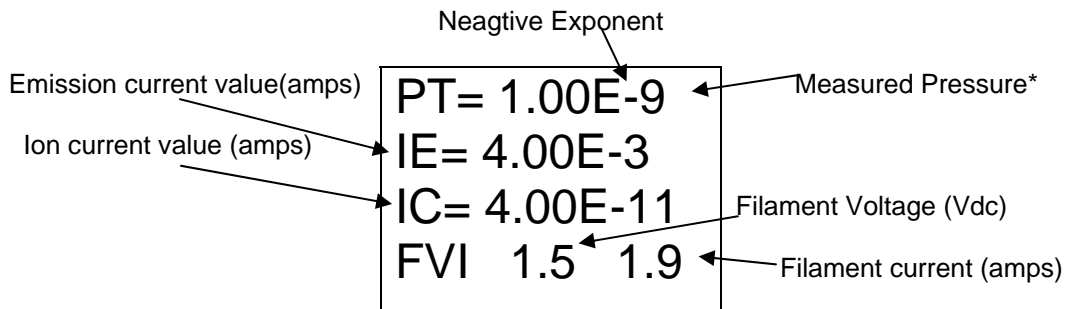

-FLIP SCREEN [Factory default = *NORMAL*]

This allows the user to select a *NORMAL* display or have the data displayed UPSIDE DOWN. When the IGM is mounted upside down, this is used to invert the display screen 180 degrees for user convenience. Note: When Upside Down is selected, the user has to save the setting and exit the menu before the measured values are displayed upside down.

SETUP UNIT

- UNITS: [Factory default = *TORR*]

Select from Torr, mbar or Pascal. Units selected are used for all other settings.

- DEFAULTS: [Factory default = *MENU TO EXIT*]

The module can be returned to the original factory settings by using the ENTER Key to set factory defaults. Note: You must re-enter the actual sensor sensitivity value marked on the sensor tube.

- GAS TYPE: [Factory default = *N2*]

Use the UP and DOWN Keys to select from a table of 16 common gases. Gas choices are as follow:

N₂, Air, O₂, CO, H₂O, NO, Ar, CO₂, Kr, SF₆, Xe, Hg, He, Ne, D₂, H₂

Caution: If you intend to use Nitrogen as the default gas even though the gas in use is not Nitrogen, you can select N2 from the menu but you must manually apply a gas sensitivity correction factor to the displayed measurement and outputs. (Refer to section on Gas Sensitivity Correction Factor).

- INPUT CNTL [Factory default = *DIGI/RS485*]

This allows the user to turn the filaments on/off, select emission current and turn Degas on/off using digital inputs, RS485 communication commands or the front panel push buttons.

DIGI/RS485: The DIGI/RS485 allows the application of actual digital inputs or RS485 communication to operate the IGM. The default state of the DIGI/RS485 selection is Digital inputs. This requires application of digital inputs to pins 1, pin 6 and pin 8 of the **Analog DSUB** (Analog 9 pin connector) to operate the IGM. (see table 1) User should verify the DIGI/RS485 is selected in the INPUT CNTRL submenu of the SETUP UNIT menu. When operating in the *Digital Input* mode, all other inputs are ignored.

To change from Digital Input to RS485 communication mode use the **RS485 DSUB** (RS485 9 pin connector). (see table 2) User should verify DIGI/RS485 is selected in the INPUT CNTRL submenu of the SETUP UNIT menu. In order to operate in the RS-485 mode, the user must send an RS485 **set command** which will cause the IGM to automatically switch to RS-485 mode. (Note: A set command such as turn filament on/off must be sent to the IGM in order for the gauge to auto switch to RS485. Sending **read commands** such as read gauge pressure will not accomplish this task). When operating in the *RS485* mode, all other inputs are ignored.

Note: To turn off RS-485 interface, the reset command must be sent to the IGM or power must be turned off and on. This will reset INPUT CNTL to DIGI/RS485 factory default setting with the default state of this selection being the Digital inputs again.

FRONT PANEL: This allows the user to turn the filaments on/off, select emission current and turn Degas on/off using the front panel push buttons. This is achieved by selecting Front Panel in the INPUT CNTRL submenu of the SETUP UNIT menu. In this case the FRONT PANEL overrides any other input and the *DIGI/RS485* inputs are ignored. If Front Panel is selected the FP OPERATE submenu will appear in the SETUP UNIT menu. Access FP Operate submenu next.

- FP OPERATE {Appears in the SETUP UNIT menu only after FRONT PANEL is selected in the *INPUT CNTL menu*. The following screen will appear if FP OPERATE is selected:

UNIT ON/OFF: [Factory default = OFF] Access setting to turn the gauge/filament on or off.

EMISSION SEL: [Factory default = 100UA] Access setting to change emission current to 4 ma or 100 UA.

DEGAS ON/OFF: [Factory default = OFF] Access setting to turn Degas on or off.

SETUP IG

- DEGAS TIME: [Factory default = 2]

The length of time in minutes degassing will run after it is initiated. Degas cycle can be selected from 2 to 10 minutes.

- OVER PRESS 4: [Factory default = $1.30E-03$ TORR]

This allows the user to set the pressure at which the gauge will turn off when the emission current is running at 4 ma. Any value higher than $1.30E-03$ TORR can not be set.

- OVER PRESS 100: [Factory default = $5.00E-02$ TORR]

This allows the user to set the pressure at which the gauge will turn off when the emission current is running at 0.1 ma (100uA). Any value higher than $5.00E-02$ TORR can not be set.

- SENSITIVITY: [Factory default = *Actual Sensor sensitivity*]

Factory pre-set based on individual tube calibration. All sensor tubes are marked with their specific sensitivity value. Also user adjustable between 2 to 99 using the display commands.

Caution: User assumes all risks if sensitivity is set to a value not matching the actual sensor sensitivity marked on the sensor tube.

- FILAMENT NUM: [Factory default = *FILAMENT 1*]

Allows user to select which filament to operate:

Filament 1 or Filament 2

(Note: It is highly recommended to periodically alternate operating Filaments 1 and 2. An inactive Filament not operating for an extended length of time can cause failure of that Filament. This will be more problematic in dirty applications.)

- RLY LO TRIP: [Factory default = $1.00E-06$ TORR]

This setpoint corresponds to the turn on points for the relay. The relay will turn on when the pressure drops below this setting.

- RLY HI TRIP: [Factory default = $5.00E-06$ TORR]

This setpoint corresponds to the turn off points for the relay. The relay will turn off when the pressure rises above this setting.

- RELAYTEST: [Factory default = ON]

This allows the user to manually turn the relay on and off to test wiring and ensure polarity is as desired.

- VENT DETECT [Factory default = *OM*]

When VENT DETECT is ON it provides a quick vent protection of the filaments in the event of a system dump to atmosphere. In **rare** cases this protection could cause the filament not to start properly after filaments have been shut down. If such is the case, you can change the VENT DETECT setting to Off so the filament can receive full power in spite of conditions. NOTE: User should turn VENT DETECT OFF only if vent to atmosphere can either be prevented or the gauge can be turned off by external means

- FIL USAGE: [Factory default = *all at zero*]

This allows the user to view how many hours each filament has been turned on and how many minutes degassing has been applied to each Filament. The Display in this screen provides the following data"

F1: # H (Number of hours Filament 1 has been in use).

F2: # H (Number of hours Filament 2 has been in use).

D1: # M (Number of minutes Filament 1 has been degassed).

D2: # M (Number of minutes Filament 2 has been degassed).

The usage numbers are non-resetable. The user should record the usage time when replacing the Ion gauge sensor.

SETUP COMMS

- BAUD RATE: [Factory default = *19200, 8 , N , 1*]

This sets the baud rate for the RS485 communications. The baud rate can be set to many other values through the serial interface command set. The parity can also be changed. When this occurs, the current setting will be shown in the list of choices and can be re-selected if changed.

- ADDR: [Factory default = *1*]

This is the lower nibble of the one byte RS485 device address. (e.g. Setting this to a 5 would make the address be 0x05 in hex; a 15 would be 0x0F in hex; if the address offset is equal to 0.)

- ADDR OFFSET [Factory default = *0*]

This is the upper nibble of the one byte RS485 address. (e.g. Setting this to a 5 (with ADDR = 0) would make the address 0x50, a 15 would be 0xF0.)

SERVICE

-INFO

Provide Software Version number

-OP TIME

Provides information on how long the unit has been on regardless of Filament operation.

RS485 Interface

RS485 Command Protocol Summary

Note: Note: This protocol was designed to be 100% compatible with the Micro-Ion[®].

COMMAND	BRIEF DESCRIPTION	COMMAND SYNTAX	RESPONSE
READ	Read the current pressure in Torr	#xxRD<CR> (eg: #01RD<CR>)	*xx_y.yyEzyy<CR> (eg: *01_7.60E+02<CR>)
SET ADDR OFFSET	Set the communications (RS485) address offset (upper nibble) *	#xxSAxx<CR> (eg: #01SA04<CR>)	*xx_PROGM_OK<CR>
TOGGLE MODULE STATUS	Power up the filament and start reading pressure.	#xxlGy<CR> (eg: #01lG1<CR>) y=1 Turn ON;y=0 Turn OFF	*xx_PROGM_OK<CR>
TOGGLE DEGAS STATUS	Start a degas cycle or turn off.	#xxDGy<CR> (eg: #01DG1<CR>) Y=1 Turn ON;y=0 Turn OFF	xx_PROGM_OK<CR>
SET EMISSION STATUS	Choose 4mA or 100uA emission current.	#xxSEy<CR> (eg: #01SE1<CR>) y=1 4mA; y=0 100uA	xx_PROGM_OK<CR>
SET FILAMENT	Choose Filament 1 or 2.	#xxSFy<CR> (eg: #01SF1<CR>) y=1 for F1;y=2 for F2	xx_PROGM_OK<CR>
SET OVER PRESSURE SETPOINT	Set 100uA overpressure turn-off point.	#xxSOy.yyE-yy<CR> (eg: #01SO4.00E-02<CR>)	xx_PROGM_OK<CR>
SET TRIP POINT #1	Set the 'turns on below' pressure point for relay #1 and set the 'turns off above' pressure point for relay #1.	#xxSLzy.yyEzyy<CR> (eg: #01SL+4.00E+02<CR>) (eg: #01SL-5.00E+02<CR>)	*xx_PROGM_OK<CR>
READ MODULE STATUS	Find out if filament is powered up and gauge is reading.	#xxlGS<CR> (eg: #01lGS<CR>)	*xx_0_IG_OFF<CR> *xx_1_IG_ON<CR>
READ TRIP POINT #1	Read the 'turns on below' pressure point for relay #1 and read the 'turns off above' pressure point for relay #1.	#xxRLz<CR> (eg: #01RL+<CR>) (eg: #01RL-<CR>)	*xx_y.yyEzyy<CR> (eg: *01_7.60E+02<CR>)
READ DEGAS STATUS	Find out if the module is currently degassing.	#xxDGS<CR> (eg: #01DGS<CR>)	*xx_0_DG_OFF<CR> *xx_1_DG_ON<CR>
READ EMISSION STATUS	Find out emission current level.	#xxSES<CR> (eg: #01SES<CR>)	*xx_0.1MA_EM<CR> *xx_4.0MA_EM<CR>
READ MODULE STATUS	Finds out the cause of the controller shutdown.	#xxRS<CR> (eg: #01RS<CR>)	*xx_00_ST_OK *xx_01_OVPRS *xx_02_EMISS

COMMAND	BRIEF DESCRIPTION	COMMAND SYNTAX	RESPONSE
READ SW VERSION	Read the revision number of the firmware.	#xxVER<CR> (eg: #01VER<CR>)	*xx_mmmnv-vv (eg: *0105041-00)
SET FACTORY DEFAULTS	Force unit to return ALL settings back to the way the factory programmed them before shipment.	#xxFAC<CR> (eg: #01FAC<CR>)	*xx_PROGM_OK<CR>
SET BAUD RATE	Set the communications baud rate for RS485 and RS232.*	#xxSByyyyy<CR> (eg: #01SB19200<CR>)	*xx_PROGM_OK<CR>
SET NO PARITY	Set the communications to NO parity, 8 bits for the RS485 and RS232.*	#xxSPN<CR> (eg: #01SPN<CR>)	*xx_PROGM_OK<CR>
SET ODD PARITY	Set the communications to ODD parity, 7 bits for the RS485 and RS232.*	#xxSPO<CR> (eg: #01SPO<CR>)	*xx_PROGM_OK<CR>
SET EVEN PARITY	Set the communications to EVEN parity, 7 bits for the RS485/ RS232.*	#xxSPE<CR> (eg: #01SPE<CR>)	*xx_PROGM_OK<CR>
UNLOCK COMM PROGRAMMING (UNL)	If the UNL command is enabled by the TLU command, the UNL command must be executed in sequence prior to the SB, SPN, SPO, and SPE commands. Not sending the UNL will yield a response of ?xx_COMM_ERR<CR>. If UNL is not enabled, then a response would be ?xx_SYNTAX_ER<CR>.	#xxUNL<CR> (eg: #01UNL<CR>)	*xx_PROGM_OK<CR>
TOGGLE UNL FUNCTION (TLU)	The TLU command will toggle the state of the UNL function. When the response is UL_ON, then UNL is required to execute SB, SPN, SPO, and SPE. When response is UL_OFF, then UNL is not required and sending a UNL will generate a ?xx_SYNTAX_ER<CR>.	#xxTLU<CR> (eg: #01TLU<CR>)	*xx_1_UL_ON<CR> *xx_0_UL_OFF<CR>
RESET	Reset the device as if power was cycled. (required to complete some of the commands.)	#xxRST<CR> (eg: #01RST<CR>)	No response

* Commands marked with an asterisk will not take effect until after RESET command is sent or power is cycled.

NOTES:

1. All Responses are 13 characters long.
2. xx is the address of the device. (00 thru FF)
3. <CR> is a carriage return.
4. _ is a space.
5. All commands sent to the module start with a '#' character, and all responses from the module start with a '*' or a "?" character.
6. This protocol was designed to be 100% compatible with the Micro-Ion[®].

Service & Maintenance**Calibration:**

Every InstruTech module is calibrated prior to shipment using Nitrogen. Care should be exercised when using gases other than nitrogen N₂ (See Section on Gas Sensitivity Correction Factor).

Troubleshooting

<i>Indication</i>	<i>Possible Cause</i>	<i>Possible Solution</i>
Display is off / blank	No power The connector may not be wired correctly	check cable connections and verify that power is being supplied. check cable connections and verify that power is being supplied.
Readings appear very different from expected pressure	Sensor not in the proper location to measure system pressure The process gas is different from the gas (Nitrogen) used to calibrate the IGM. Sensor has been dropped causing mechanical damage The gauge sensor tube is contaminated Leak in the vacuum system	ensure the sensor is located in appropriate location apply Gas sensitivity correction factor if applicable. See Table 3 or select the appropriate gas from the IGM display menu replace the Ion gauge sensor tube degas the sensor Re-check for leak in the system Re-check that all metal O-rings are used when operating below 1.0E-07 TORR
Ion gauge can not be turned on	Pressure exceeds 1.30E-03 TORR at 4 ma emission Pressure exceeds 5.0E-02 TORR at 0.10 ma (100uA) emission Emission Control not functioning	decrease pressure below required value decrease pressure below required value switch to the other filament replace Ion gauge sensor tube due to possible filament failure or contamination
Research Screen shows filament Voltage is present but filament current stays at 0	Filament is open	switch to the other filament or replace sensor
Research Screen shows filament Voltage and filament current are present but gauge is shutting off	Filament is contaminated or burned out	switch to the other filament or replace sensor
Unable to initiate Degas	System pressure above 5.0×10^{-5}	decrease pressure below the required value
Voltage to Filament too high	Filament contaminated or near end of its life	switch to the other filament or replace sensor
Setpoint does not actuate	Incorrect setup	check setpoint setup

Sensor Replacement

The IGM module is factory calibrated for the specific Ion gauge sensor tube installed in it. If the gauge sensor fails for any reason, it can be replaced with a new one. The sensitivity of the new sensor must be re-programmed in the IGM electronics. Follow all instructions below in order to replace the sensor tube in the field. If you prefer, you can contact the factory for return authorization, and the replacement of the sensor can be done at the factory.

Sensor/Filament Functionality:

The IGM Electronics detects whether or not the Filaments are functional. Should any of the Filaments fail, the IGM display will show the following:

F1 Open (indicating Filament number 1 has failed.)

F2 Open (indicating Filament number 2 has failed.)

Sensor Replacement:

To replace the sensor use the following procedure:

1. Turn off power to the IGM.
2. Disconnect the cable from the IGM.
3. Remove the IGM401 from the vacuum system.
4. Use 3/32 size Allen Wrench to remove the #4-40 socket head cap screws as shown below.
5. Detach the metal enclosure and the electronics from the sensor.
6. Replace sensor.
7. Reprogram new sensor's sensitivity.

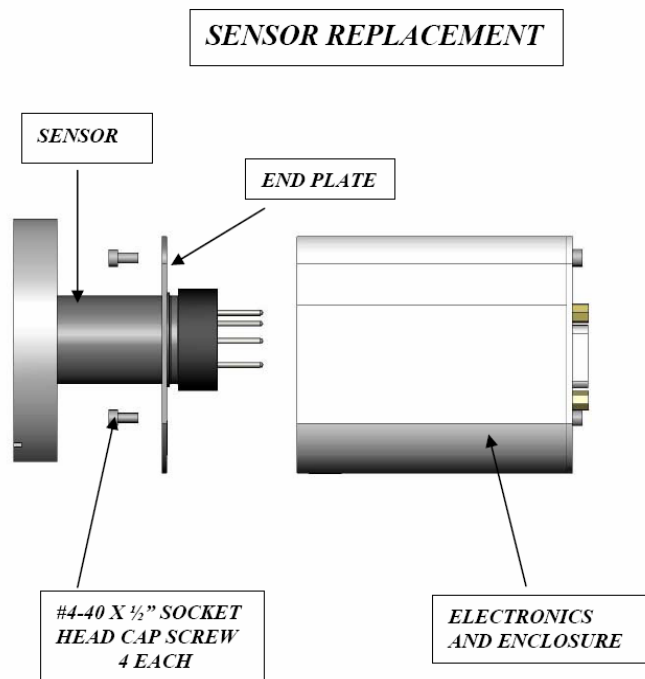

Figure 9 – IGM401 Sensor Replacement

Factory Service and Support

If you need help setting up, operating, or troubleshooting your module, you are welcome to call us during normal business hours (8:00am to 5:00pm Mountain time) Monday through Friday, at 303-651-0551 or e-mail us at info@instrutechinc.com.

If it becomes necessary to return the module to InstruTech for service or calibration, please call or e-mail us for a return authorization number. For the safety of our employees, you must download a material disclosure form from our website at www.instrutechinc.com. Please use this form to provide a history of the gauge detailing what gases have been used. We cannot work on gauges that have been exposed to hazardous materials.

Warranty

SELLER warrants that its products, are free of defects in workmanship and material and fit for the uses set forth in SELLER's catalog or product specifications, under the normal use and service for which they are intended.

The entire warranty obligation of SELLER is for the repair or replacement, at SELLER's option, of products or parts (examination of which shall disclose to SELLER's satisfaction that it is defective) returned, to SELLER's plant, properly identified within eighteen (18) months (unless otherwise noted) after the date of shipment from InstruTech Plant. BUYER must obtain the approval of SELLER and a return authorization number prior to shipment.

Alteration or removal of serial numbers or other identification marks renders this warranty void. The warranty does not apply to products or components which have been abused, altered, operated outside of the environmental specifications of the product, improperly handled or installed, or units which have not been operated in accordance with SELLER's instructions. Furthermore the warranty does not apply to products that have been contaminated, or when the product or part is damaged during the warranty period due to causes other than ordinary wear and tear to the product including, but not limited to, accidents, transportation, neglect, misuse, use of the product for any purpose other than that for which it was designed.

THIS WARRANTY IS EXCLUSIVE AND IN LIEU OF ALL OTHER WARRANTIES, EXPRESS OR IMPLIED, INCLUDING ANY IMPLIED WARRANTY OF MERCHANTABILITY OR FITNESS FOR A PARTICULAR PURPOSE. THIS WARRANTY EXTENDS ONLY IN FAVOR OF THE ORIGINAL BUYER. THE BUYER'S SOLE REMEDY SHALL BE THE REPAIR OR REPLACEMENT, AS IS EXPRESSLY PROVIDED HEREIN, OF ANY WARRANTED DEFECTIVE PRODUCT OR PART, AND UNDER NO CIRCUMSTANCE SHALL SELLER BE LIABLE TO BUYER OR ANYONE ELSE FOR ANY CONSEQUENTIAL DAMAGES TO PERSONS OR PROPERTY, FOR INCIDENTAL DAMAGES OR LOSS OF TIME, FOR ANTICIPATED OR LOST PROFITS, OR ANY OTHER LOSS INCURRED BY THE BUYER RELATED TO THE PRODUCT COVERED BY THIS WARRANTY. THIS EXCLUSIVE REMEDY SHALL NOT BE DEEMED TO HAVE FAILED OF ITS ESSENTIAL PURPOSE SO LONG AS SELLER IS WILLING AND ABLE TO REPAIR OR REPLACE DEFECTIVE PARTS IN THE PRESCRIBED MANNER. THIS LIMITED WARRANTY MAY NOT BE MODIFIED BY SELLER UNLESS SUCH MODIFICATION OR WAIVER IS IN WRITING, EXECUTED BY AN AUTHORIZED OFFICER OF SELLER.

Trademarks & Acknowledgements

These trademarks, used throughout this manual, are the property of the following companies: Micro-Ion[®] are registered trademarks of Brooks Automation/Helix Technology Corp/Granville Phillips. Conflat[®] and Mini-Conflat[®] are registered trademarks of Varian Vacuum Technology. Cajon[®] and VCR[®] are registered trademarks of the Swagelok Company. Teflon[®] is a registered trademark of DuPont.