

SuperLogic[®]

Professional Commercial Reverse Osmosis



SuperLogic 1500 Installation and Operation Manual



- **SuperLogic®** 1,500 gpd system.
- High flow, low energy membrane
- **Automated** TDS controller and monitor with simultaneous feed and product readout
- Carbon fiber face plate
- Rinsable sediment and **Eco-Green Carbon** block prefiltration
- Anti-scalant cartridge for use in hard water applications
- Brine and product flowmeters
- Prefilter In/Out gauges
- Membrane In/Out gauges
- Stainless steel waste water recirculation valve
- Stainless steel heavy duty commercial pump
- Low pressure cut-off switch
- Non-petroleum bioplastic fittings
- Manufactured in the USA
- All systems QC tested and verified

Introduction

Congratulations on the purchase of your SuperLogic commercial reverse osmosis system. This is professional water purification equipment which, with proper care and maintenance can last you for many years.

Feed water conditions can vary drastically as well as fluctuate at your specific site. In order retain your warranty, the provided operating log must be maintained and available for our review.

Prior to starting up the SuperLogic reverse osmosis systems this user manual must be fully read and understood. Keep this manual in a safe place for future reference. A copy of this manual can be found at www.hydrologicsystems.com.

System Specifications

HL Model Number	31043
Capacity (gpd)¹	1,500
Membrane Type	4" x 21" high flow, low energy, thin-film
Number of Membranes	1
Membrane TDS Rejection¹	96%+
Prefilters	10" rinsable sediment (5 micron) 10" Green Carbon block (10 micron)
Pretreatment	Anti-scalant cartridge
Pump	325 gph
Motor	3/4 Hp
Minimum Feed (GPM)	4 GPM
Feed Connection	Female garden hose
Brine Connection	3/8" tube
Product Connection	3/8" tube
Dimensions	18"W x 26"D x 30"H
Weight	100 lbs

¹Based on membrane performance after 24 hours, 77°F (25°C), 500 ppm TDS, 120 psi and 66% recovery. Membrane performance may vary ±15%.

Feed Water and Operating Specifications

Important Note: Feed water quality has a great effect on the performance of your reverse osmosis. It is very important to meet the minimum feed water requirements. Failure to do so will cause the membranes to foul and void the warranty.

Feed Pressure	40-80 psi
Max Operating Pressure	150 psi
Temperature	40° - 100°F
Max Chlorine (continuous)	<0.3 ppm
Max Total Dissolved Solids	5,000 ppm
Hardness	<15 grains
Silt Density Index	<5 SDI
Turbidity	<1 NTU
pH Range	2-11
Silica	< 1 ppm
Iron, Hydrogen Sulfide or Manganese	0 ppm

Please Note:

Higher TDS and/or lower temperatures will reduce the systems performance

Detailed water analysis available. All levels of pre and post filtration available to match source water.

Call HydroLogic directly for assistance (888) 426.5644

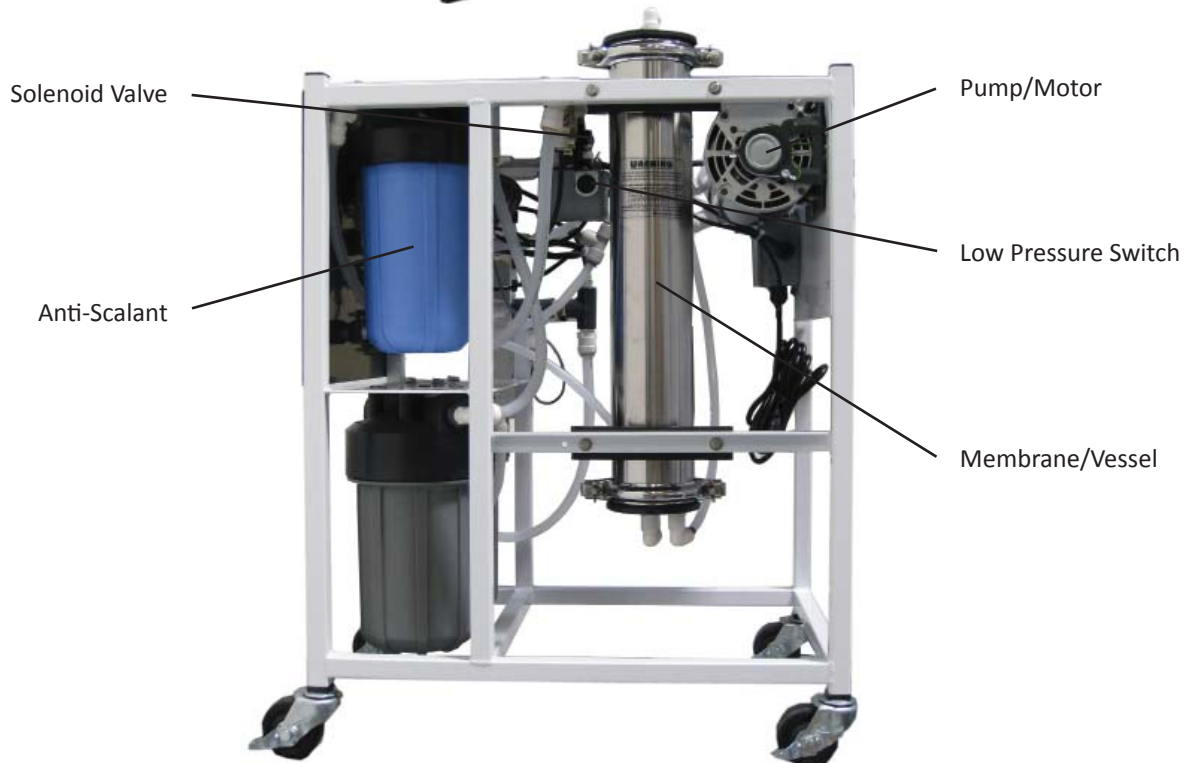
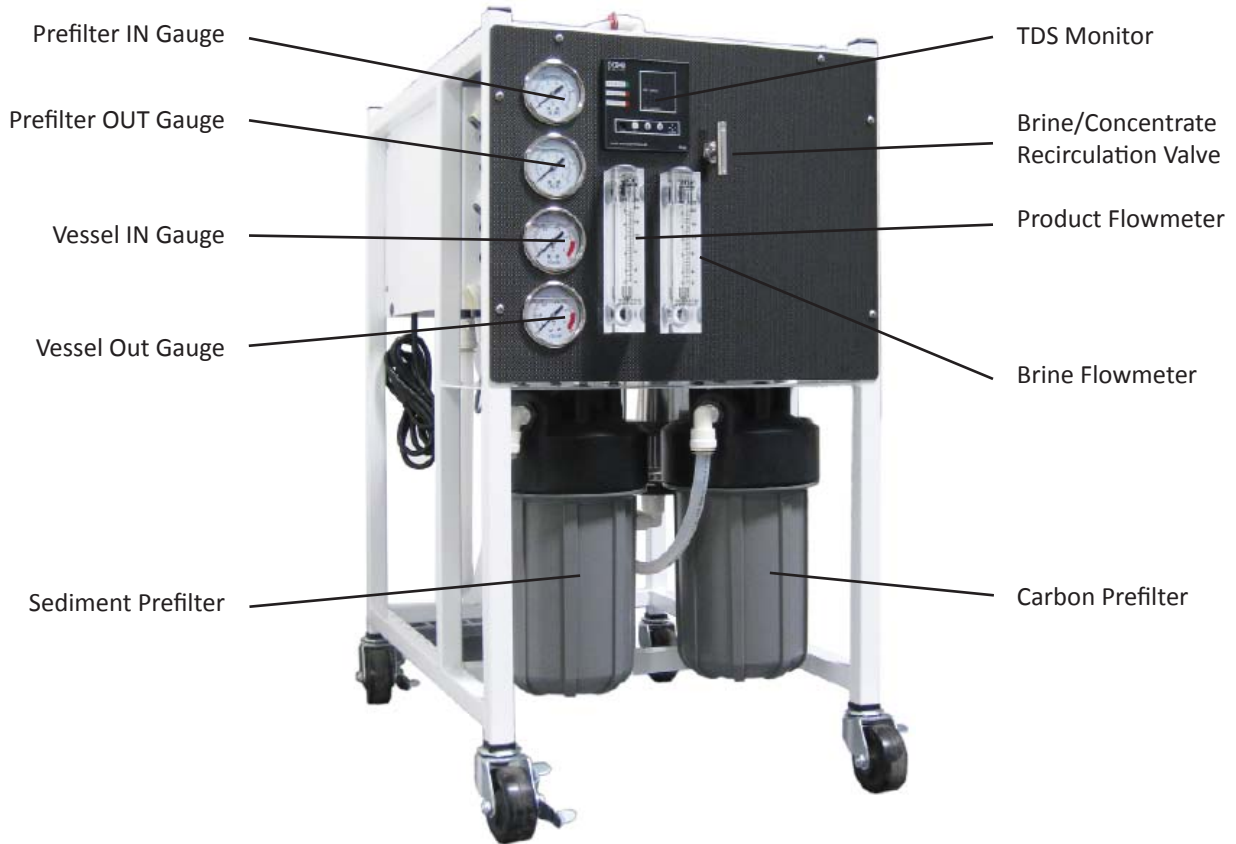

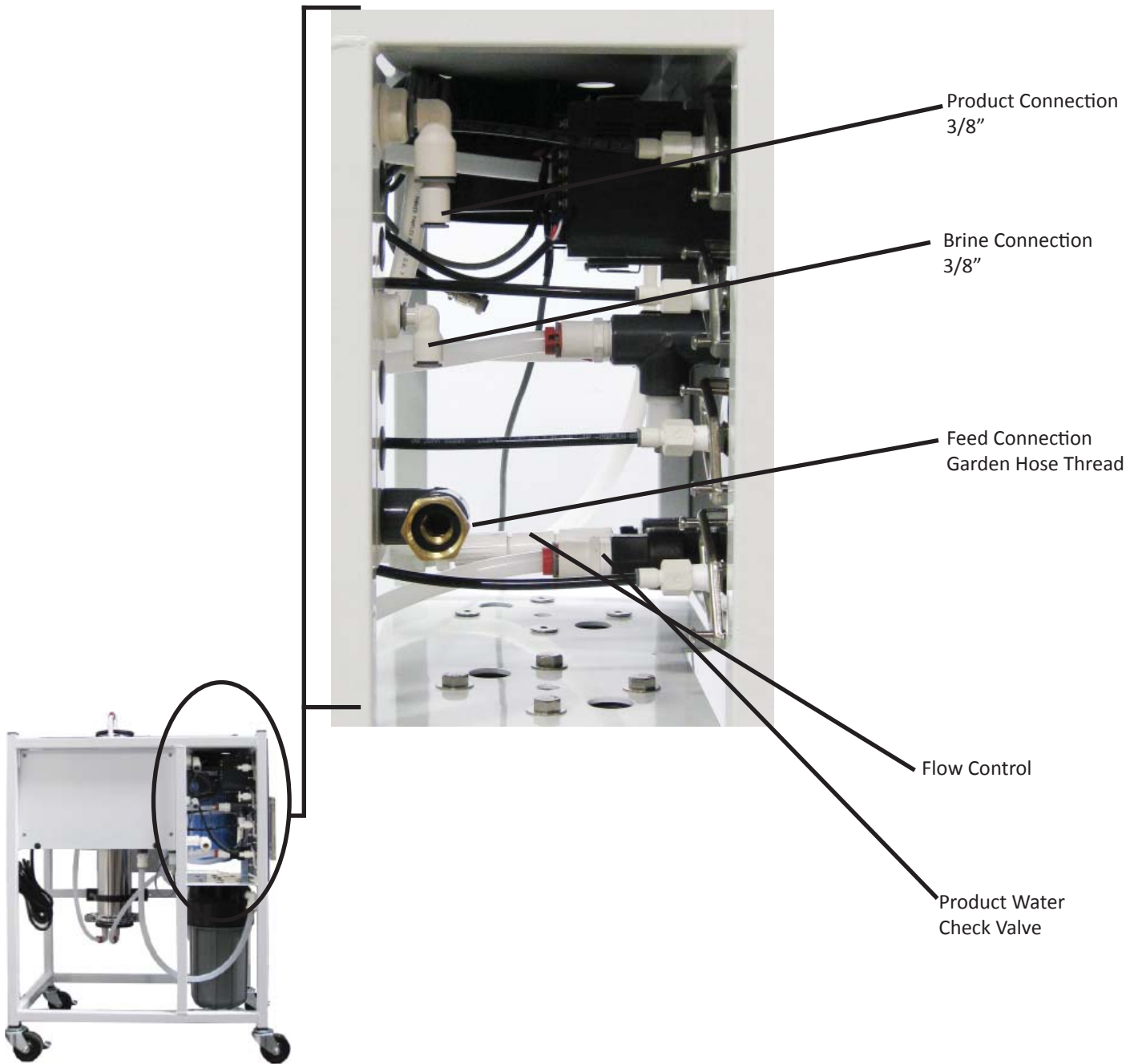

Anti-Scalant Cartridge: Allows the system to be operated at a 2:1 product to brine recovery ratio by preventing membrane fouling due to hardness in the feed water. The system can also be specified for a 4:1 product to brine ratio if a proper water softener or anti scalant system is installed prior to the SuperLogic. Contact us for details @ (888) 426-5644.

Brine/Concentrate Recirculation Valve: A needle valve that controls the amount of brine from the membrane to be recirculated back into the feed stream. This feature allows for higher recovery rates (lower waste water ratios). Additionally, adjustment of this valve regulates the pump discharge pressure.

Filter IN/OUT Pressure Gauges: Gauges that display the water pressure before and after the sediment prefilter. Used to observe the pressure drop through the sediment prefilter (a means of detecting filter clogging or loading).

Flow Control: A fixed orifice that controls the amount of water flowing across the membrane to drain. This controls the ratio for product water to waste water and either comes at a 4:1 or 2:1 ratio depending on how the system was specified.

Low Pressure Switch: An electrical switch that shuts off the unit in the event of low feed water pressure. This is used as a pump protection device. This is factory set to cut off at 12 psi (0.8 bar).

Membrane/Vessel (Desalinators): Separates dissolved solids from the feed water. This assembly consists of a stainless steel pressure vessel that houses the thin-film, reverse osmosis (RO) membrane.

Prefilter, Carbon: A 10 micron Eco-Green carbon block prefilter that removes chlorine prior to entering the membrane.

Prefilter, Sediment: A pleated filter that prevents undissolved particles larger than 5 micron, from entering the system.

Product Water Check Valve: A one-way valve that prevents pressurized product water from flowing back into the desalinators (and possibly damaging the membrane) when the system is off.

Pump/Motor: The rotary positive displacement pump boosts water pressure in the desalinators up to 150 psi (10.3 bar) for low energy membranes to ensure high solids rejection and high flow rates.

Solenoid Valve: Electrically operated valve that prevents water from flowing through the system when it is not in operation.

Vessel Pressure IN/OUT Gauges: Gauges that display the operating pressure before and after the RO membrane (used to observe drop in membrane pressure indicating fouling or clogging).

TDS Monitor: Simultaneously reports the feed and product water TDS in ppm. Includes optional alarm function. A low PPM limit can be programmed so the system shuts down if PPM's go above set point.

Pre-Installation Procedures

PLEASE READ CAREFULLY. FAILURE TO FOLLOW THESE PROCEDURES CAN RESULT IN DAMAGE TO YOUR SYSTEM AND VOID YOUR WARRANTY.

Packaging

Upon delivery, inspect packaging and report any damage to your carrier immediately. After unpacking the system, inspect it carefully for signs of damage. All damage claims should be made to the delivery carrier.

Operating Parameters

The SuperLogic 1500 system may only be used on potable water. The user must be sure that water to be treated is both microbiologically safe and non-toxic. Ensure that the operating parameters outlined on page 3 are met at the installation site. Items of most importance are TDS, feed water pressure, flow rate, chlorine level and temperature range. A water analysis is helpful in determining if any pre-treatment is needed. If your water analysis shows levels of substances in excess of the maximums, contact HydroLogic for pre-treatment recommendations. Contact HydroLogic to inquire about a detailed water analysis.

Installation/Start up Procedure

PLEASE READ CAREFULLY. FAILURE TO FOLLOW THESE PROCEDURES CAN RESULT IN DAMAGE TO YOUR SYSTEM AND VOID YOUR WARRANTY.

Location

Locate the system where it will be protected from harsh conditions such as rain, snow, direct sunlight and extreme temperatures (both hot and cold). The SuperLogic 1500 system can be located just about anywhere there is a water supply and electrical outlet. This system is equipped with casters and may be rolled to different locations for operation. Keep in mind, however, that the system should be out of normal traffic patterns yet accessible for daily monitoring and service.

Plumbing

(Figure 1 - Flow Diagram)

Always abide by local plumbing codes when installing the system.

Water Supply Connection

Connect feed water supply line to the female garden hose connector. Many other inlet fitting options are available through HydroLogic. If the supply water is being drawn from a non-pressurized source (gravity feed), contact HydroLogic for additional information. Minimum inlet pressure is 40 psi. If your inlet psi is below 40 contact HydroLogic for further information.

Drain Connection

Connect a 3/8" line from the quick connect elbow marked DRAIN to an appropriate drain point. A quick connect drain saddle is available as an option from HydroLogic and can be plumbed directly into the main train of a sink. Be sure to check your local plumbing codes to see if an air gap between the system and the drain is required.

Product Connection

The product water connection to the storage tank should not be made until the system is flushed and tested as outlined below.

Tank Connection (For Non-Pressurized Tanks Only)

When using a non-pressurized storage tank, connect the 3/8" tubing marked PRODUCT to the tank. Use an optional electronic float switch to shut down the system when the tank is full and start the system when water level is low. Quick connect bulk head fittings are available to connect the product line to your tank. Contact HydroLogic for this and other options available.

Figure 1 - Flow Diagram

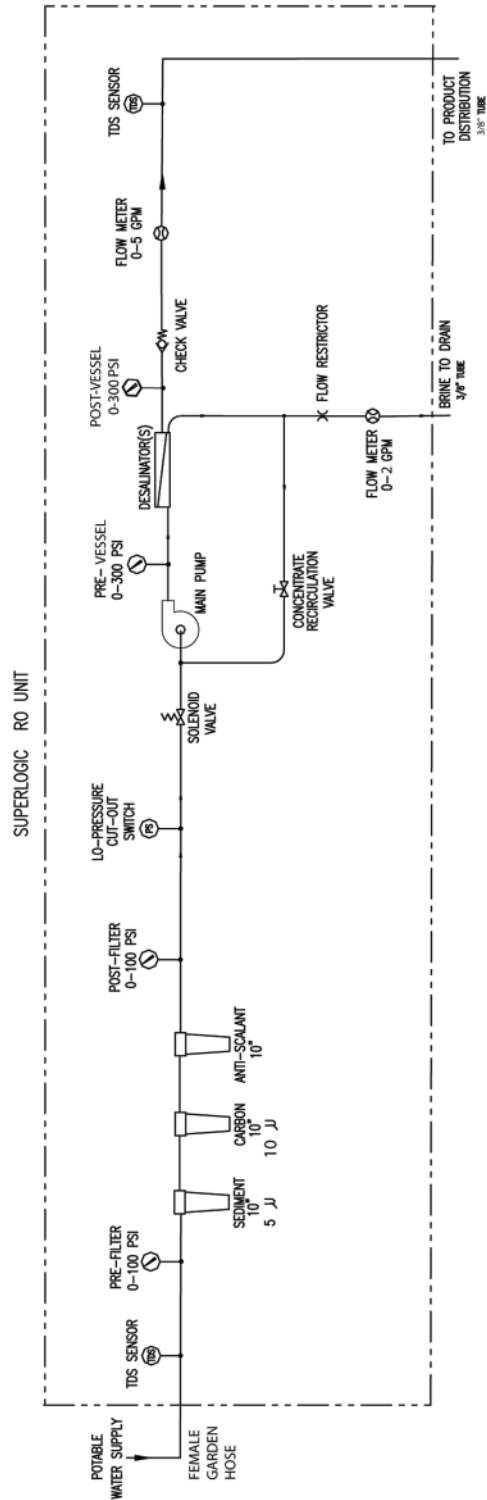

Electrical

(Figure 2 - Electrical Diagram)

WARNING! THE SYSTEM CAN START AT ANY TIME WHEN POWER IS CONNECTED. DO NOT CONNECT POWER UNTIL THE SYSTEM IS COMPLETELY INSTALLED AND READY TO RUN.

The SuperLogic 1500 system is built with a standard 115v three-prong plug. Be sure the receptacle you use is on a circuit that has a Ground Fault Interrupter (GFCI) and has sufficient capacity for the operating current as listed in the system specifications. It is recommended that the system be installed on a dedicated circuit to prevent overloading on system start-up.

Optional External Float Switch Wiring (For non-pressurized tanks only)

A piggy-back connector is supplied with the system. Please see additional installation information included with the float switch.

Figure 2 - Electrical Diagram

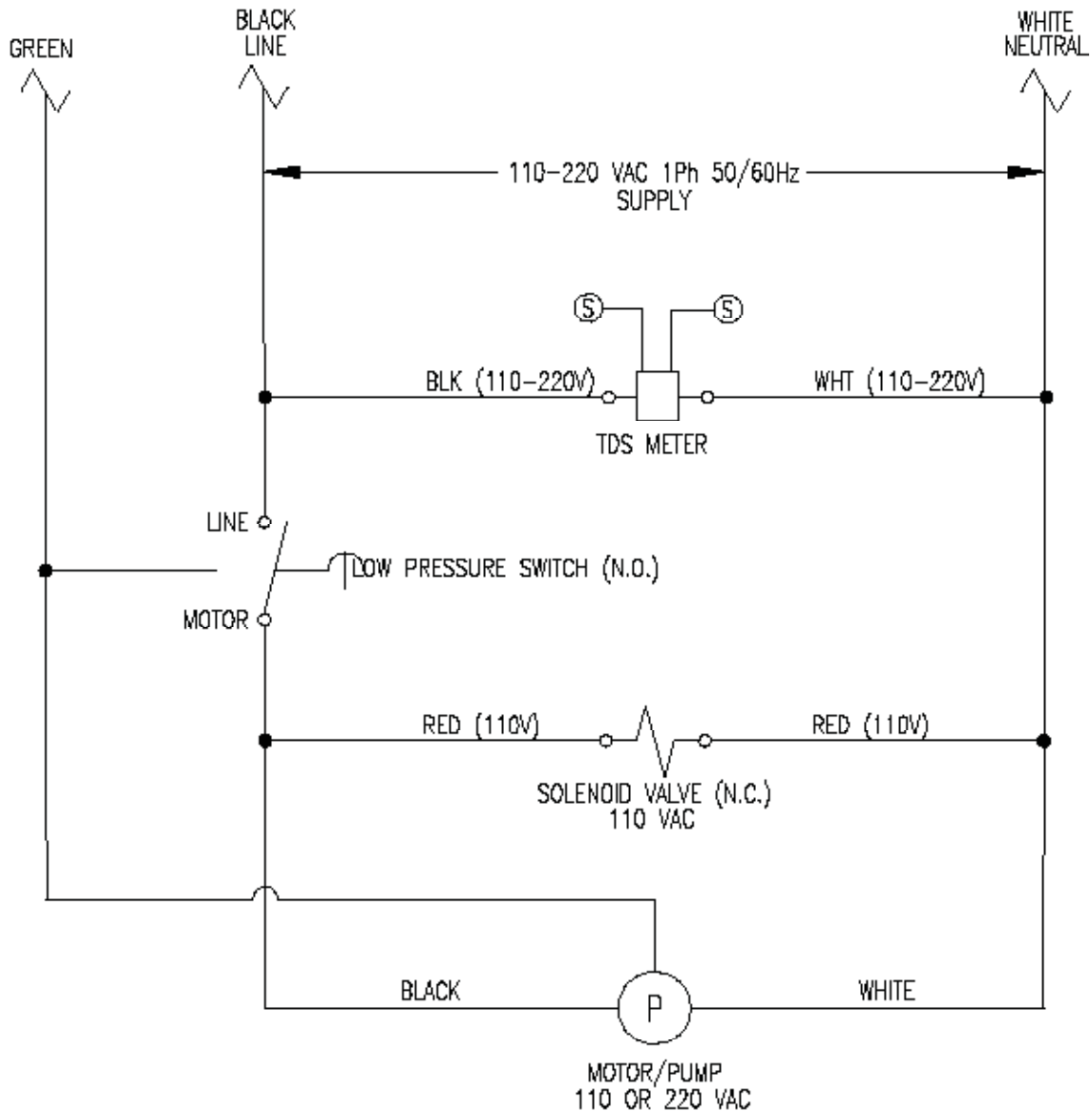

System Flush and Performance Verification

Although SuperLogic 1500 systems are fully tested at the factory prior to shipping, it is recommended to flush and verify your system's performance on-site.

Flushing

New membranes are shipped with a preservative that needs to be flushed out before use. Run the product line to drain while flushing the system.

- Fully open the brine/concentrate recirculation valve by turning the knob counterclockwise.
- Turn on water supply to the unit and check for leaks at the pre filter housings and the feed connections.
- Plug the system into a compatible electrical outlet. CAUTION! THE SYSTEM WILL START and rapidly cycle, starting and stopping until the membrane vessels are full of water and water starts flowing out of the product and brine ports.
- After the system has run for a few minutes to clear any air, turn the brine/concentrate recirculation valve clockwise until the "vessel in" pressure gauge reads 120 psi (8.3 bar).
- Allow the system to flush for one hour with all water discharged to drain. Periodically check for leaks and check the "vessel in" pressure gauge. It is likely that the vessel pressure will drift from 120 psi (8.3 bar) during the flushing. If it does, turn brine/concentrate recirculation valve clockwise to increase pressure and counterclockwise to decrease pressure.
- The recirculation valve will need to be adjusted when membranes are replaced or if there are seasonal changes in water temperature that cause the pump pressure to drift by 10 psi or more.
- The 120 psi pressure provides the best compromise of membrane performance and lifetime while maintaining pump and motor longevity. The system can operate above 120 psi and up to a maximum of 150 psi. Inlet water temperature and TDS can effect the flow rate of purified water and in situations with low water temperatures and/or high TDS increased pressure may be necessary to achieve desired flow rates of purified water.

*** DO NOT LET SYSTEM PRESSURE RISE ABOVE 150 PSI (10.3 BAR) AS DAMAGE TO THE SYSTEM CAN OCCUR***

Performance Verification

Factory test data is supplied with the system. To ensure optimal performance, on-site data should be taken and compared to the factory test data. This data should be taken after the system has been flushed for one hour. Some deviations may be seen due to differences in feed water TDS and temperature between the site and factory. If you have already connected the product line to the tank, you will need to disconnect it to take product samples.

Flow Tests

Determine the flow rates for both product and brine. Put the product line into a container and measure the volume of water that flows into it in one minute. Repeat the process with the brine (drain) line. These values should be in either gallons per minute or milliliters per minute. Product flow rates (at 77°F, 25°C) should be within 15% of the production rates given in the system specifications.

Product to Brine/Concentrate Ratio

Compute the product to brine ratio by dividing the brine flow rate by the product flow rate. This ratio should be either 4:1 or 2:1 ± 30%. The 30% variation can be due to inlet water temperature being above or below 77 degrees fahrenheit as well as inlet TDS being above or below 500 PPM.

Total Dissolved Solids (TDS) rejection

Using the TDS monitor, note the TDS in both the feed water and the product water.

Calculate percent rejection using the formula: $(\text{Feed TDS} - \text{Product TDS}) \div (\text{Feed TDS}) \times 100 = \% \text{ Rejection}$

Rejection should be 85% or better. For example, where the feed TDS is 600 and the product TDS is 24, the percent rejection is: $(600 - 24) \div 600 \times 100 = 96\%$

Low Pressure Switch Test

While the system is running, shut off the water supply to the system. The system should shut off. If the system does not shut off after ten seconds, either unplug the system or restore the water supply to the system. Call HydroLogic to diagnose problem.

DO NOT LET THE SYSTEM RUN WITHOUT THE WATER SUPPLY TURNED ON. PUMP DAMAGE WILL OCCUR.

Tank Connection

Make the tank connection as outlined on page 8.

Optional Float Switch Test (for non-pressurized tanks)

The system should run when the float is hanging down by the power cord. Tilt float up so the power cord is at the bottom of the float. The unit should shut off. If unit does not shut off, re-check installation procedure.

Operation and Maintenance

SuperLogic 1500 systems are designed for simple operation with little user intervention. We recommend keeping accurate performance records and following a regular preventative maintenance schedule to maximize the life of your system.

Daily System Checks

Your water supply pressure can vary from time to time. This can also affect your system operating pressure. Check and adjust your vessel pressure daily to ensure maximum water production rates and quality. Check both the prefilter in pressure gauge and pre filter out pressure gauge. Under normal conditions, there should be a 3-5 psi difference between the two gauges. When the difference reaches 10 psi it is recommended to change your pre-filters.

Monthly System Checks

In addition to the daily checks, it is recommended to repeat the procedure in the section on Performance Verification and record all data on a performance record sheet.

Semi-Annual Service

It is recommended to change both sediment and carbon filter cartridges at least every six months. Carbon cartridges should be changed more often if bad taste and/or odor becomes evident. Sediment cartridge should be changed more often if water supply pressure and filter pressure gauges differ by 10 psi or more.

Peripheral Equipment

Peripheral equipment such as tanks also have periodic maintenance requirements. It is essential to maintain these as they can have a dramatic effect on the performance of your system. Refer to their specific manuals for proper maintenance procedures.

Filter/Membrane Replacement Schedule

Sediment pre-filter - The 5 micron sediment filter is pleated and can be rinsed with a garden hose. You can rinse as often as needed but it is recommended to replace this filter every 6 months. If you observe a 10 psi drop in the pre-filter out gauge from the psi in the pre-filter in gauge this indicates a clog in the sediment filter and you should either rinse it or replace it.

Carbon Pre-Filter - The 10 micron carbon filter is rated at 2 PPM chlorine removal and should be changed according to the schedule below:

@ 4:1 ratio replace every 25,000 gallons of product water

@ 2:1 ratio replace every 15,000 gallons of product water

Anti-Scale Pre-Filter - Should be replaced every time the carbon filter is replaced

Membrane - Upon startup the vessel in gauge should read 120 while the vessel out gauge will always read approximately 10 psi less or 110 psi. When the vessel out gauge reads 20 psi lower than the vessel in gauge, or 100 psi, this indicates when to change your membrane.

Limited Warranty

This Limited Warranty extends to the original purchaser of the unit. This warranty covers all parts and factory labor needed to repair any manufacturer supplied item that proves to be defective material, workmanship or factory preparation. The above-mentioned warranty applies for the first full calendar year from the date of purchase. These defective items are subject to the following exclusions: membranes, filters, O-rings, and all other parts or components that require regular replacement as a result of ordinary usage.

Disclaimers: This Warranty applies only if the unit is installed and used in compliance with the instructions enclosed with the unit.

The Warranty does not cover any unauthorized parts or parts not included on the original unit. This Warranty does not cover the costs of repairs or adjustments to the unit that may be needed because of the use of improper parts, equipment or materials. This Warranty does not cover repairs required due to use of unauthorized parts, unauthorized alterations of the unit, failure of a unit caused by such alterations or by unauthorized repairs.

The Warranty does not cover malfunctions of the unit due to tampering, misuse, alteration, lack of regular maintenance, misapplication, fouling due to hydrogen sulfide or iron, scaling from excessive hardness, or excessive membrane hydrolysis due to chlorine levels in excess of 1.0 mg/L, or operating at too high a recovery. In addition, damage to the unit due to fire, accident, negligence, act of god, or events beyond the control of the manufacturer are not covered by this warranty.

The manufacturer warrants the membranes per the original manufacturers warranty. These warranties generally cover faulty material and workmanship for anywhere from one to three years. Membrane fouling is not covered.

The manufacturer warrants all items supplied by outside vendors, per the manufacturers warranties. These warranties generally cover faulty material and workmanship for one year.

Incidental and Consequential Damages: The manufacturer does not assume responsibility for payment of incidental damages as a result of the failure of this unit to comply with express or implied warranties, such as lost time, inconvenience, damage to personal property, loss of revenue, commercial losses, postage, travel, telephone expenditures, or other losses of this nature. Some states do not allow the exclusion or limitation of incidental or consequential damages, so this exclusion may not apply to you.

Owner's Warranty Responsibilities: Under the provisions of this Warranty, the owner is expected to perform timely maintenance, as described in this Manual. Neglect, improper maintenance, abuse, or unapproved modifications may invalidate the Warranty. Should your unit develop a defect or otherwise fail to perform in accordance with this warranty, you should contact HydroLogic.

Implied Warranties: Implied at-law warranties of merchantability and fitness for a particular purpose shall terminate on the date one year after the date of purchase. Note: some states do not allow limitations on how an implied warranty lasts, so the above limitations may not apply to you.

Other Rights This Warranty gives you specific legal rights and you may also have other rights that vary from state to state.

Returned Goods Authorization In order to process a return, a Returned Goods Authorization (RGA) number will be assigned. Include the RGA number with an explanation of the defect with the item being returned. Items returned under the RGA process will be reviewed and/or forwarded to the original manufacturer for evaluation. Items returned must be sent prepaid.

