

COLORrail™ IRC IP

User Manual

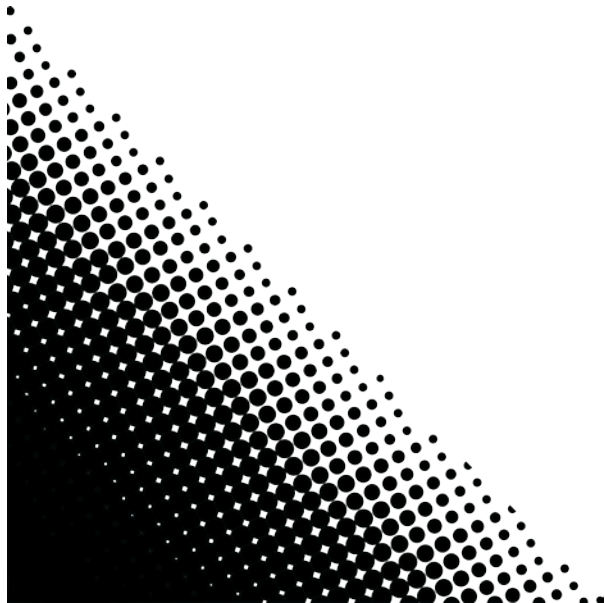
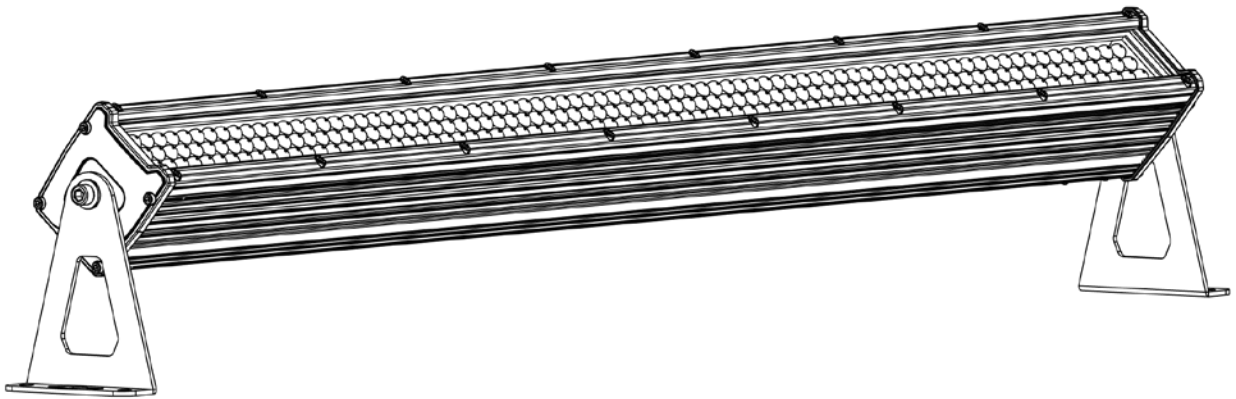

CHAUVET®
Value · Innovation · Performance
It's **Green** Thinking.™

TABLE OF CONTENTS

1. Before You Begin	3
What Is Included	3
Unpacking Instructions	3
Claims	3
Text Conventions	3
Icons	3
Disclaimer	3
Product at a Glance	4
Safety Notes	4
2. Introduction	5
Product Overview	5
Product Dimensions	5
3. Setup	6
AC Power	6
Power Linking	6
Mounting	6
Orientation	6
Rigging	6
4. Operation	7
Control Panel Operation	7
Configuration (DMX)	7
DMX Personalities and Starting Address	7
Menu Map	8
DMX Channel Assignments and Values	9
2-CH	9
3-CH	9
4-CH	9
7-CH	9
14-CH	10
26-CH	11
Configuration (Standalone)	12
Auto Run Mode	12
Auto Programs	12
Master/Slave Mode	12
Infrared Control	12
IRC (Infrared Remote Control) Operation	13
5. Technical Information	14
Product Maintenance	14
6. Technical Specifications	15
Contact Procedure	16
Returning Products to CHAUVET®	16
CHAUVET® Contact Information	16

1. BEFORE YOU BEGIN

What Is Included

- COLORrail™ IRC IP
- DMX In Adapter
- DMX Out Adapter
- Power Cord
- Warranty Card
- Quick Reference Guide

Unpacking Instructions

Immediately upon receipt, carefully unpack the product and check the box to make sure you have received all the parts indicated above in good condition.

Claims



If the box or the contents (the product and included accessories) appear damaged from shipping, or show signs of mishandling, upon receipt notify the carrier immediately, not CHAUVET®. Failure to do so in a timely manner may invalidate your claim with the carrier. In addition, keep the container and all the packing material for inspection.

For other issues such as missing components or parts, damage not related to shipping, or concealed damage, file a claim with CHAUVET® within 7 days of receiving the merchandise.

Text Conventions

Convention	Meaning
1–512	A range of values
50/60	A set of values of which only one can be chosen
Settings	A menu option not to be modified
Menu > Settings	A sequence of menu options to be followed
<ENTER>	A key to be pressed on the product's control panel
ON	A value to be entered or selected

Icons

Icon	Meaning
	Critical installation, configuration, or operation information. Failure to comply with this information may render the product partially or completely inoperative, cause damage to the product, or cause harm to the user.
	Important installation or configuration information. Failure to comply with this information may prevent the product from functioning correctly.
	Useful information.

Disclaimer

The information and specifications contained in this document are subject to change without notice. CHAUVET® assumes no responsibility or liability for any errors or omissions that may appear in this manual. CHAUVET® reserves the right to update the existing document or to create a new document to correct any errors or omissions.

You can download the latest version of this document from www.chauvetlighting.com.

© Copyright 2013 CHAUVET®. All rights reserved.

Electronically published by CHAUVET® in the United States of America.

Author	Date	Editor	Date
A. Leon	06/07/13	T. Yeago	06/17/13

Product at a Glance

Use on Dimmer	X	Auto Programs	P
Outdoor Use	P	Auto-ranging Power Supply	P
Sound-Activated	X	Replaceable Fuse	X
DMX	P	User-Serviceable	X
Master/Slave	P		

Safety Notes

Please read the following Safety Notes carefully before working with the product. The Notes include important safety information about installation, usage, and maintenance.



- Always connect the product to a GFI (ground fault interrupter) circuit to avoid the risk of electrocution.
- Always disconnect the product from the power source before cleaning.
- Avoid direct eye exposure to the light source while the product is on.
- Make sure the power cord is not crimped or damaged.
- Never disconnect the product from power cord by pulling or tugging on the cord.
- If mounting the product overhead, always secure to a fastening device using a safety cable.
- Make sure there are no flammable materials close to the product when operating.
- Do not touch the product's housing when operating because it may be very hot.



- Always make sure that the voltage of the outlet to which you are connecting the product is within the range stated on the decal or rear panel of the product.
- The product is for indoor or outdoor use (IP65). Do not submerge the product.
- Always install the product in a location with adequate ventilation, at least 20 in (50 cm) from adjacent surfaces.
- Never connect the product to a dimmer.
- Never carry the product from the power cord or any moving part. Always use the hanging/mounting bracket or the handles.
- The maximum ambient temperature (Ta) is 104° F (40° C). Do not operate the product at higher temperatures.
- In the event of a serious operating problem, stop using the product immediately.
- Never try to repair the product. Repairs carried out by unskilled people can lead to damage or malfunction. Please contact the nearest authorized technical assistance center.



- Keep this User Manual for future consultation. If you sell the product to another user, be sure that they also receive this document.

2. INTRODUCTION

Product Overview

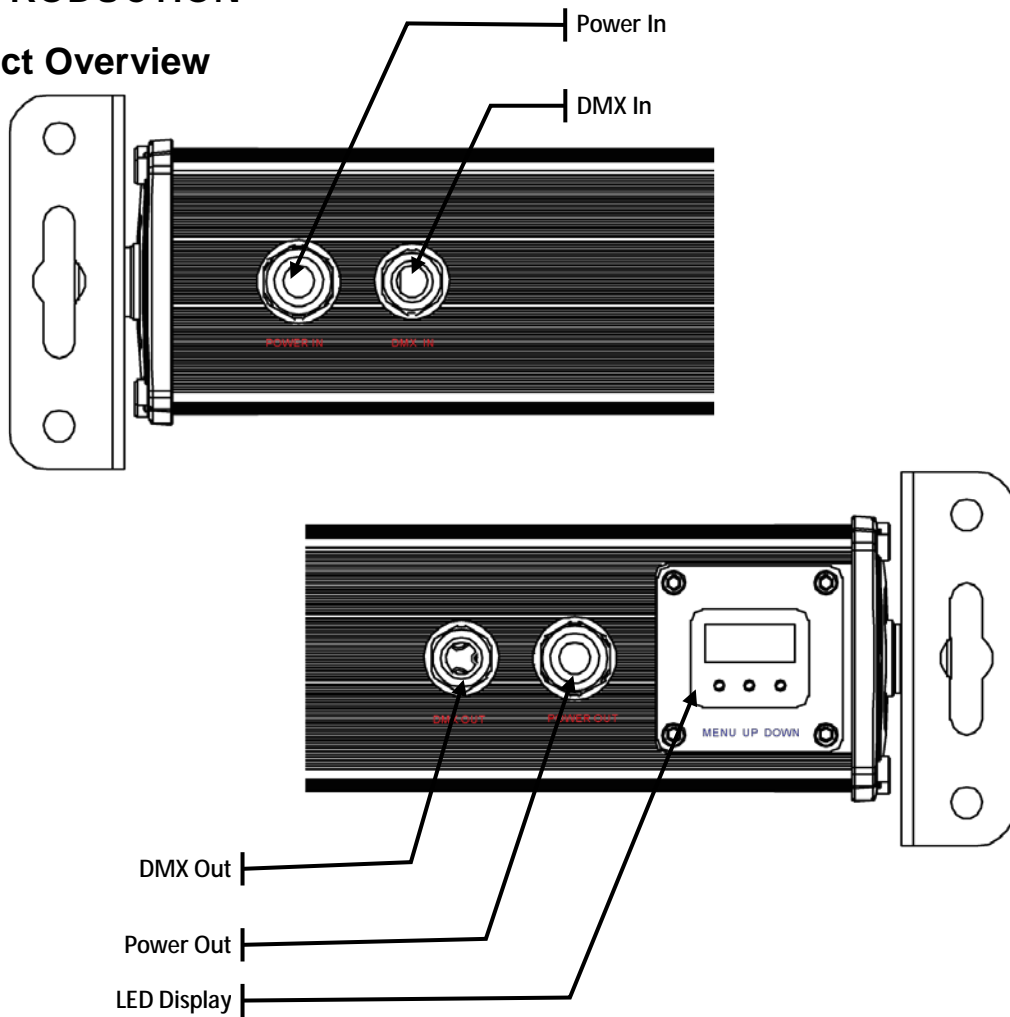

Product Dimensions

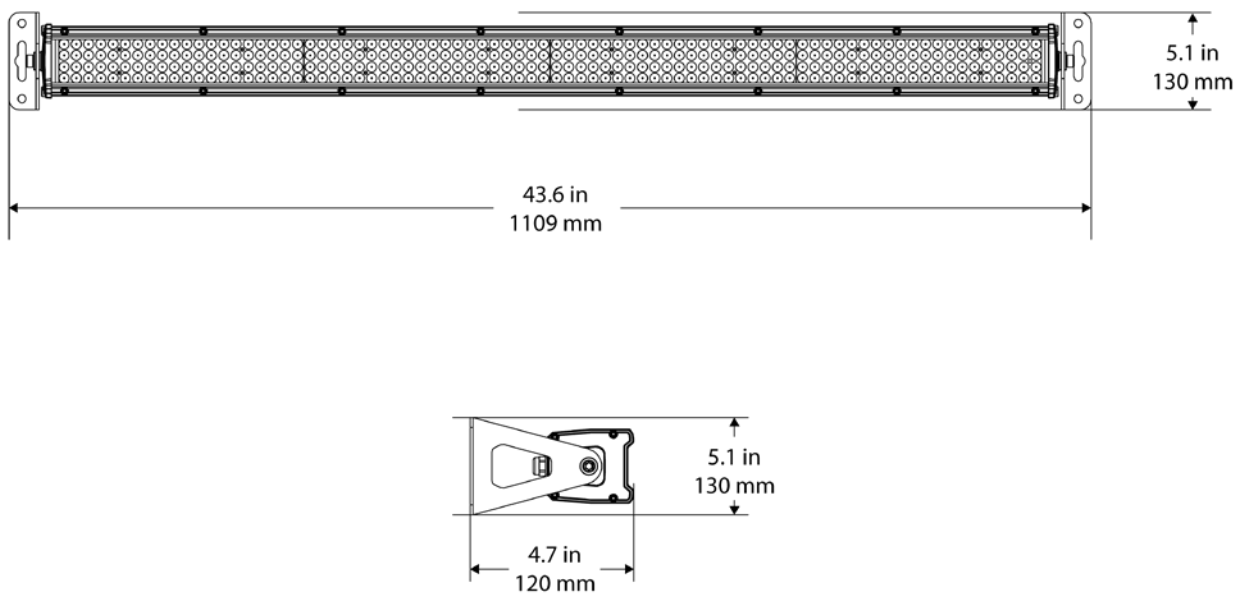

3. SETUP

AC Power The COLORrail™ IRC IP has an auto-ranging power supply and it can work with an input voltage range of 100–240 VAC, 50/60 Hz.

To determine the product's power requirements (circuit breaker, power outlet, and wiring), use the current value listed on the label affixed to the product's back panel, or refer to the product's specifications chart. The listed current rating indicates the product's average current draw under normal conditions.



Always connect the product to a GFI protected circuit (circuit breaker or fuse). Make sure the product has an appropriate electrical ground to avoid the risk of electrocution or fire.



Never connect the product to a rheostat (variable resistor) or dimmer circuit, even if the rheostat or dimmer channel serves only as a 0 to 100% switch.

Power Linking The product provides a power linking option via the pigtails located on the back of the unit.

You can daisy chain up to 15 units on 120 VAC or up to 28 units on 230 VAC.

If you choose not to use the power linking feature, be sure to use the included screw on cap to prevent any water from getting into the power cords.



The power linking diagram shown above corresponds to the North American version of the product ONLY! If using the product in other markets, you must consult with the local CHAUVET® distributor as power linking connectors and requirements may differ in your country or region.

Mounting Before mounting the product, read and follow the safety recommendations indicated in the Safety Notes.

Orientation The COLORrail™ IRC IP may be mounted in any position; however, make sure adequate ventilation is provided around the product.

- Rigging**
- Before deciding on a location for the product, always make sure there is easy access to the product for maintenance and programming purposes.
 - Make sure that the structure or surface onto which you are mounting the product can support the product's weight. Please see the *Technical Specifications* section of this manual for weight information.
 - When mounting the product overhead, always use a safety cable. Mount the product securely to a rigging point, whether an elevated platform or a truss.
 - When rigging the product onto a truss, you should use a mounting clamp of appropriate weight capacity. The bracket has a 13 mm hole, which is appropriate for this purpose.
 - When power linking multiple products, you must always consider the length of the power linking cable and mount the products close enough for the cable to reach.
 - The bracket adjustment knobs allow for directional adjustment when aiming the product to the desired angle. Only loosen or tighten the bracket knobs manually. Using tools could damage the knobs.

Mounting Diagram

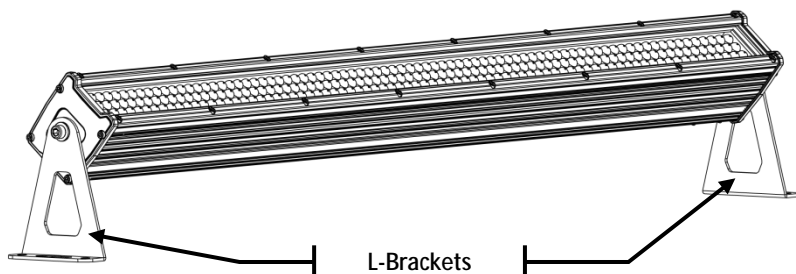

4. OPERATION

Control Panel Operation

To access the control panel functions, use the four buttons located underneath the display. Please refer to the Product Overview to see the button locations on the control panel.

Button	Function
<MENU>	Press to find an operation mode or to back out of the current menu option
<UP>	Press to scroll up the list of options or to find a higher value
<DOWN>	Press to scroll down the list of options or to find a lower value
<ENTER>	Press to activate a menu option or a selected value

Configuration (DMX)

Set the product in DMX mode to control with a DMX controller.

1. Connect the product to a suitable power outlet.
2. Turn the product on.
3. Connect a DMX cable from the DMX output of the DMX controller to the DMX input socket on the product.

DMX Personalities and Starting Address

The COLORrail™ IRC IP has six DMX personalities, a 2-channel mode for basic control and a 26-channel mode with more advanced control over the lights.

The COLORrail™ IRC IP uses up to 26 DMX channels in its 26-channel DMX mode, which defines the highest configurable address to **487**.

When selecting a starting DMX address, always consider the number of DMX channels the selected DMX mode uses. If you choose a starting address that is too high, you could restrict the access to some of the product's channels.

If you are not familiar with the DMX protocol, you may refer to the DMX Primer at www.chauvetlighting.com.

To select the DMX personality, do the following:

1. Press <MENU> repeatedly until **__c** shows on the display.
2. Press <ENTER>.
3. Press <MENU> repeatedly until **2-c, 3-c, 4-c, 7-c, 14c** or **26c** shows on the display
4. Press <ENTER> to choose your DMX personality when it appears on the display.

To then choose your starting address:

1. Press <MENU> repeatedly until **001** shows on the display.
2. Press <ENTER>.
3. Use <UP> or <DOWN> to select the starting address.
5. Press <ENTER>.

Menu Map

Mode	Programming Steps		Description		
Auto Run	AUR	n__	01-99, FL Number of loops		
		S.__	01-99, FL Run speed (slow to fast)		
		F.__	00-99 Strobe speed (slow to fast)		
DMX Channels and Personalities	001	001-512	Sets DMX address		
	__c	2-c	Sets DMX personality		
		3-c			
		4-c			
		7-c			
		14c			
26c					
Slave Mode	SLA		Sets Slave functionality		
IR Controller	ir-		IRC functionality		
Auto Programs	P.01	1.-r	Red		
		2.r9	Yellow		
		3.-9	Green		
		4.9b	Cyan		
		5.-b	Blue		
		6.rb	Magenta		
		7.FL	White		
		8.OF	Off		
		F.01-F.99	Strobe speed (slow to fast)		
	P.02-P.20	S.01-S.99, S.FL	Run speed (slow to fast)		
		F.00-F.99	Strobe speed (slow to fast)		
	P.__	S.01-S.99, S.FL	Run speed (slow to fast)		
			F.00-F.99	Strobe speed (slow to fast)	
		P.21-P.22	1.-r	Red	Foreground Color
			1.r9	Yellow	
			1.-9	Green	
			1.9b	Cyan	
			1.-b	Blue	
			1.rb	Magenta	
			1.FL	White	
			1.FF	Off	
		P.21-P.22	2.-r	Red	Background Color
			2.r9	Yellow	
			2.-9	Green	
2.9b			Cyan		
2.-b			Blue		
2.rb	Magenta				
2.FL	White				
2.FF	Off				

DMX Channel Assignments and Values

2-CH	Channel	Function	Value	Setting
1	Color Macros	000 ◊ 008	No function	
		009 ◊ 017	Red	
		018 ◊ 026	Yellow	
		027 ◊ 035	Green	
		036 ◊ 044	Cyan	
		045 ◊ 053	Blue	
		054 ◊ 062	Magenta	
		063 ◊ 071	White	
		072 ◊ 242	Auto Programs	
		243 ◊ 255	Reserved	
2	Auto Program Speed	000 ◊ 255	Slow to fast (when Ch. 1 is 072–255)	

3-CH	Channel	Function	Value	Setting
1	Red	000 ◊ 255	0–100%	
2	Green	000 ◊ 255	0–100%	
3	Blue	000 ◊ 255	0–100%	

4-CH	Channel	Function	Value	Setting
1	Master Dimmer	000 ◊ 255	0–100%	
2	Red	000 ◊ 255	0–100%	
3	Green	000 ◊ 255	0–100%	
4	Blue	000 ◊ 255	0–100%	

7-CH	Channel	Function	Value	Setting
1	Master Dimmer	000 ◊ 255	0–100%	
2	Red	000 ◊ 255	0–100%	
3	Green	000 ◊ 255	0–100%	
4	Blue	000 ◊ 255	0–100%	
5	Color Macros	000 ◊ 008	No function	
		009 ◊ 017	Red	
		018 ◊ 026	Yellow	
		027 ◊ 035	Green	
		036 ◊ 044	Cyan	
		045 ◊ 053	Blue	
		054 ◊ 062	Magenta	
		063 ◊ 071	White	
072 ◊ 255	Auto Programs			
6	Auto Program Speed	000 ◊ 255	Program speed slow to fast (when Ch. 5 is 072–255)	
7	Strobe	000 ◊ 255	Slow to fast	

14-CH	Channel	Function	Value	Setting
	1	Master Dimmer	000 ó 255	0-100%
	2	Red	000 ó 255	0-100%
	3	Green	000 ó 255	0-100%
	4	Blue	000 ó 255	0-100%
	5	Red	000 ó 255	0-100%
	6	Green	000 ó 255	0-100%
	7	Blue	000 ó 255	0-100%
	8	Red	000 ó 255	0-100%
	9	Green	000 ó 255	0-100%
	10	Blue	000 ó 255	0-100%
	11	Red	000 ó 255	0-100%
	12	Green	000 ó 255	0-100%
	13	Blue	000 ó 255	0-100%
	14	Strobe	000 ó 255	Slow to fast

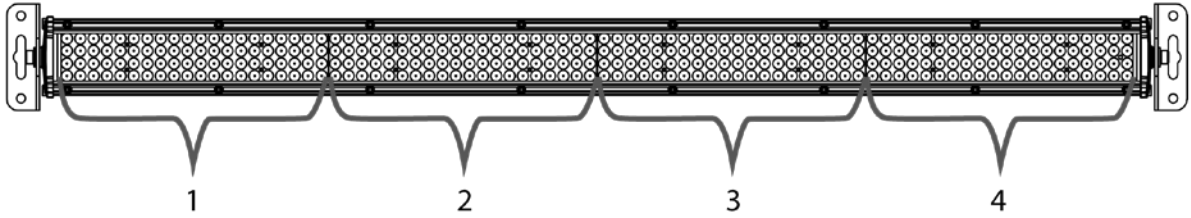

26-CH	Channel	Function	Value	Setting
	1	Master Dimmer	000 ◊ 255	0-100%
	2	Red	000 ◊ 255	0-100%
	3	Green	000 ◊ 255	0-100%
	4	Blue	000 ◊ 255	0-100%
	5	Red	000 ◊ 255	0-100%
	6	Green	000 ◊ 255	0-100%
	7	Blue	000 ◊ 255	0-100%
	8	Red	000 ◊ 255	0-100%
	9	Green	000 ◊ 255	0-100%
	10	Blue	000 ◊ 255	0-100%
	11	Red	000 ◊ 255	0-100%
	12	Green	000 ◊ 255	0-100%
	13	Blue	000 ◊ 255	0-100%
	14	Red	000 ◊ 255	0-100%
	15	Green	000 ◊ 255	0-100%
	16	Blue	000 ◊ 255	0-100%
	17	Red	000 ◊ 255	0-100%
	18	Green	000 ◊ 255	0-100%
	19	Blue	000 ◊ 255	0-100%
	20	Red	000 ◊ 255	0-100%
	21	Green	000 ◊ 255	0-100%
	22	Blue	000 ◊ 255	0-100%
	23	Red	000 ◊ 255	0-100%
	24	Green	000 ◊ 255	0-100%
	25	Blue	000 ◊ 255	0-100%
	26	Strobe	000 ◊ 255	Slow to fast

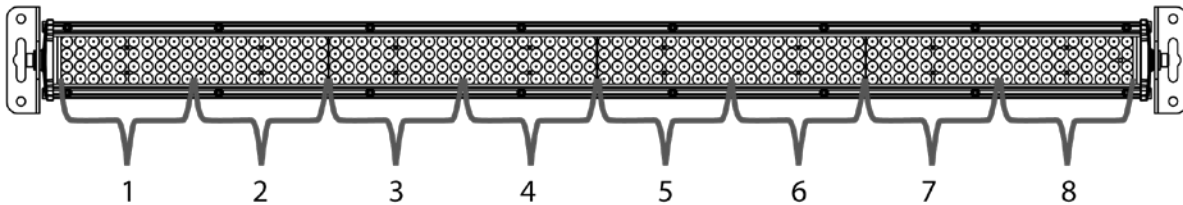

Configuration (Standalone)

Set the product in one of the standalone modes to control without a DMX controller.

1. Connect the product to a suitable power outlet.
2. Turn the product on.



Never connect a product that is operating in any standalone mode to a DMX string connected to a DMX controller. Products in standalone mode may transmit DMX signals that could interfere with the DMX signals from the controller.

Auto Run Mode

To enable the Automatic Mode, follow the instructions below:

1. Press <MENU> repeatedly until **AUR** shows on the display.
2. Press <ENTER>.
3. Use <UP> or <DOWN> to choose between programming levels.
 - a. To adjust the number of loops in the program, press <MENU> until **n__** shows, press <ENTER>, then <UP> or <DOWN> to adjust the loop numbers (**01-99, FL**).
 - b. To adjust the run speed in the program, press <MENU> until **S.__** shows, press <ENTER>, then <UP> or <DOWN> to adjust the run speed from slow to fast (**01-99, FL**).
 - c. To adjust the strobe speed in the program, press <MENU> until **F.__** shows, press <ENTER>, then <UP> or <DOWN> to adjust the strobe speed from slow to fast (**01-99, FL**).

Auto Programs

To enable the Automatic Mode, follow the instructions below:

1. Press <MENU> repeatedly until **P.__** shows on the display.
2. Press <ENTER>.
3. Use <UP> or <DOWN> to choose between auto programs (**P.01-P.22**).
4. Press <ENTER>.

Master/Slave Mode

The Master/Slave mode allows a single COLORrail™ IRC IP unit (the “master”) to control the actions of one or more COLORrail™ IRC IP units (the “slaves”) without the need of a DMX controller. The master unit will be set to operate in any standalone mode, while the slave units will be set to operate in Slave Mode. Once set and connected, the slave units will operate in unison with the master unit.

Configure the units as indicated below.

Slave units:

1. Press <MENU> repeatedly until **SLA** shows on the display.
2. Press <ENTER> to accept.
3. Set the DMX address to **001**.
4. Connect the DMX input of the first slave unit to the DMX output of the master unit.
5. Connect the DMX input of the subsequent slave units to the DMX output of the previous slave unit.
6. Finish setting and connecting all the slave units.

Master unit:

1. Set the master unit to operate in any standalone mode.
 2. Make the master unit the first unit in the daisy chain.
- **Configure all the slave units before connecting the master unit to the daisy chain.**
 - **Never connect a DMX controller to a DMX string configured for Master/Slave operation because the controller may interfere with the signals from the master unit.**
 - **Do not connect more than 31 slave units to the master unit.**



Infrared Control

The COLORrail™ IRC IP is fully compatible with the Infrared Remote Control from CHAUVET® (sold separately). To enable the IRC, follow the instructions below:

1. Press <MENU> repeatedly until **ir-** shows on the display.
2. Press <ENTER>.

IRC (Infrared Remote Control) Operation

Note: Make sure to point the IRC directly at the receiver on the product.

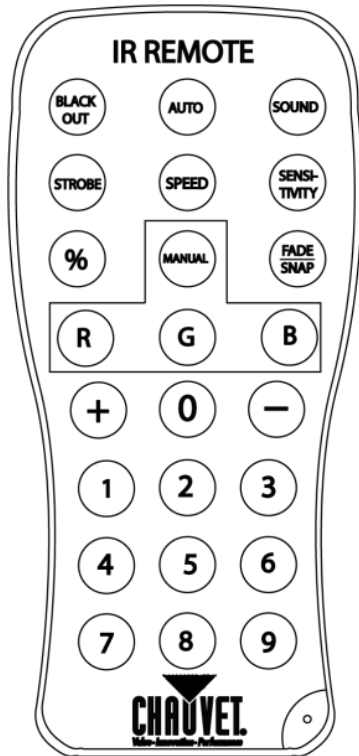

Automatic Mode

Automatic Mode will enable you to run the automatic programs on the product.

To turn on Automatic Mode:

1. Press AUTO on the IRC.
2. Press + or – to choose between the different auto programs.

To adjust the speed of the automatic program:

1. Press SPEED on the IRC.
2. Press %.
3. Press + or – to either increase or decrease the speed of the program.

Sound Active Mode (if available)

Sound Active Mode will enable the product to respond to the music.

To turn on Sound Active mode:

1. Press SOUND on the IRC.

To adjust sound sensitivity in Sound Active mode:

1. Press SENSITIVITY on the IRC.
2. Press %.
3. Press + or – to either increase or decrease sound sensitivity.

Manual Color Control

To choose a specific color with the IRC:

1. Press MANUAL on the IRC.
2. Press any number between 0-9 to choose your color.

To manually control the RGB percentage:

1. Press MANUAL on the IRC.
2. Press R, G, or B to choose your color.
3. Press + or – to increase or decrease the percentage of each color.

Miscellaneous Operation

To adjust the strobe rate of the program:

1. Press STROBE on the IRC.
2. Press + or – to increase or decrease the strobe rate.
3. Press STROBE again to turn off the strobe.

To change the switching effect of the program:

Press FADE/SNAP on the IRC.

Fade will slowly switch the effect. Snap will rapidly switch the effect.

To black out the lights:

Press BLACK OUT on the IRC.

This will turn off all the lights until the button is pressed again.

Note: The IRC will not respond to any inputs when Black Out is activated. If the remote does not respond when a button is pressed, try pressing BLACK OUT. You may have inadvertently activated BLACK OUT.

5. TECHNICAL INFORMATION

Product Maintenance

Dust build up reduces light output performance and can cause overheating. This can lead to reduction of the light source's life. To maintain optimum performance and minimize wear, you should clean your lighting products at least twice a month. However, be aware that usage and environmental conditions could be contributing factors to increase the cleaning frequency.

To clean the product, follow the instructions below:

- Unplug the product from power.
- Wait until the product is at room temperature.
- Use a vacuum (or dry compressed air) and a soft brush to remove dust collected on the external surface/vents.
- Clean all external optics and glass/transparent surfaces with a mild soap solution, ammonia-free glass cleaner, or isopropyl alcohol.
- Apply the solution directly to a soft, lint free cotton cloth or a lens cleaning tissue.
- Softly drag any dirt or grime to the outside of the external optics or glass/transparent surface.
- Gently polish the external optics and glass/transparent surfaces until they are free of haze and lint



Always dry the external optics and glass/transparent surfaces carefully after cleaning them.

6. TECHNICAL SPECIFICATIONS

Dimensions and Weight	Length	Width	Height	Weight
	43.6 in (1109 mm)	4.7 in (120 mm)	5.1 in (130 mm)	12.4 lbs (5.6 kg)
Note: Dimensions in inches rounded to the nearest decimal digit.				
Power	Power Supply Type	Range	Voltage Selection	
	Switching (internal)	100–240 V, 50/60 Hz	Auto-ranging	
	Parameter	120 V, 60 Hz	230 V, 50 Hz	
	Consumption	60 W	65 W	
	Operating	0.5 A	0.3 A	
Light Source	Power I/O	US/Worldwide	UK/Europe	
	Power input connector	Proprietary	Proprietary	
	Power output connector	Proprietary	Proprietary	
	Power Cord plug	Edison (US)	Local plug	
Photo Optic	Type	Lifespan		
	LED	50,000 hours		
	Color	Quantity		
Thermal	Red	128		
	Green	96		
	Blue	96		
	Parameter			
Illuminance @ 2 m	1140 lux			
Beam angle	28° x 12°			
Field angle	40° x 21°			
DMX	Maximum External Temp.	Minimum Startup Temp.	Cooling System	
	113° F (45° C)	-4° F (-20° C)	Convection	
Ordering	I/O Connectors	Connector Type	Channel Range	
	3-pin XLR	Proprietary	2, 3, 4, 7, 14, 26	
Ordering	Product Name	Item Code	Item Number	
	COLORrail™ IRC IP	03030121	COLORRAILIRCIP	

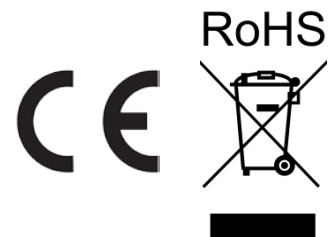

Contact Procedure

In case you need to return a product or request support, follow the procedure below:

- If you live in the U.S., contact CHAUVET® World Headquarters (see below).
- If you live in the UK or Ireland, contact CHAUVET® Europe Ltd. (see below).
- If you live in any other country, DO NOT contact CHAUVET®. Instead, contact your distributor of record. See www.chauvetlighting.com for distributors outside the U.S., United Kingdom, or Ireland.



If you live outside the U.S., United Kingdom, or Ireland, contact your distributor of record and follow their instructions on how to return CHAUVET® products to them. Visit our website for contact details.

Returning Products to CHAUVET®

Call the corresponding CHAUVET® Tech Support office and request a Return Merchandise Authorization (RMA) number before shipping the product. Be prepared to provide the model number, serial number, and a brief description of the cause for the return.

You must send the merchandise prepaid, in its original box, and with its original packing and accessories. CHAUVET® will not issue call tags.

Clearly label the package with the RMA number. CHAUVET® will refuse any product returned without an RMA number.



Write the RMA number on a properly affixed label. DO NOT write the RMA number directly on the box.

Before sending the product, clearly write the following information on a piece of paper and place it inside the box:

- Your name
- Your address
- Your phone number
- RMA number
- A brief description of the problem

Be sure to pack the product properly. Any shipping damage resulting from inadequate packaging will be your responsibility. As a suggestion, proper UPS packing or double-boxing is always a safe method to use.



CHAUVET® reserves the right to use its own discretion to repair or replace returned product(s).

CHAUVET® Contact Information

World Headquarters CHAUVET® General Information

Address: 5200 NW 108th Avenue
Sunrise, FL 33351
Voice: (954) 577-4455
Fax: (954) 929-5560
Toll free: (800) 762-1084

Technical Support

Voice: (954) 577-4455 (Press 4)
Fax: (954) 756-8015
Email: tech@chauvetlighting.com

World Wide Web

www.chauvetlighting.com

United Kingdom & Ireland CHAUVET® Europe Ltd. General Information

Address: Unit 1C
Brookhill Road Industrial Estate
Pinxton, Nottingham, UK
NG16 6NT
Voice: +44 (0)1773 511115
Fax: +44 (0)1773 511110

Technical Support

Email: uktech@chauvetlighting.com

World Wide Web

www.chauvetlighting.co.uk