

- D Montageanweisung**
- bitte aufbewahren - Änderungen vorbehalten
- GB Installation Instructions**
- please don't throw it away - subject to modification
- F Instructions de montage**
- à conserver - tous droits de modification réservés
- NL Montage-aanwijzing**
- bewaren a. u. b. - wijzigingen voorbehouden
- I Istruzioni per il montaggio**
- Attenzione: conservare - salvo variazioni
- E Instrucciones de montaje**
- pore favor guardarlas - reservado el derecho de introducir modificaciones
- P Instruções de montagem**
- e favor guardar - reservado o direito de fazer alterações
- DK Montageanvisning**
- bedes opbevaret - ret til ændringer forbeholdes
- S Monteringsanvisning**
- bewara för senare bruk - rätt till tekniska förändringar förbehålles
- N Monteringsanvisning**
- ta godt vare på denne - endringer forbeholders
- SF Asennusohje**
- Säilytä huolella - oikeus muutoksiin plätään

* falls vorhanden
only supplied with certain models
si le cas
niet bij alle apparaten aanwezig
se esistente

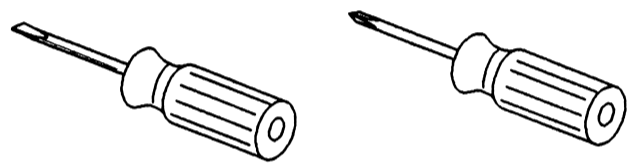

9/10/12 M SETMO QUICK 05/00 5019 106 00230

1

! Wichtig: Belüftungsquerschnitt durchgehend
! Important: Open air inlet aperture
! Important: Ouverture de circulation d'air
! Belangrijk: Vrije beluchtingsdoorsnede
! Importante: Apertura per presa d'aria

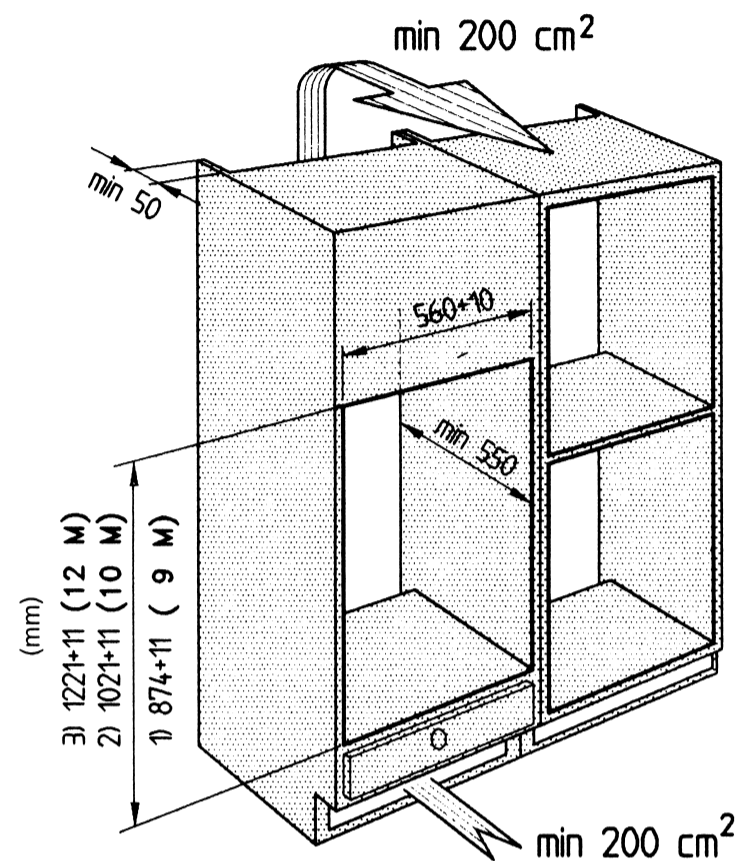

2

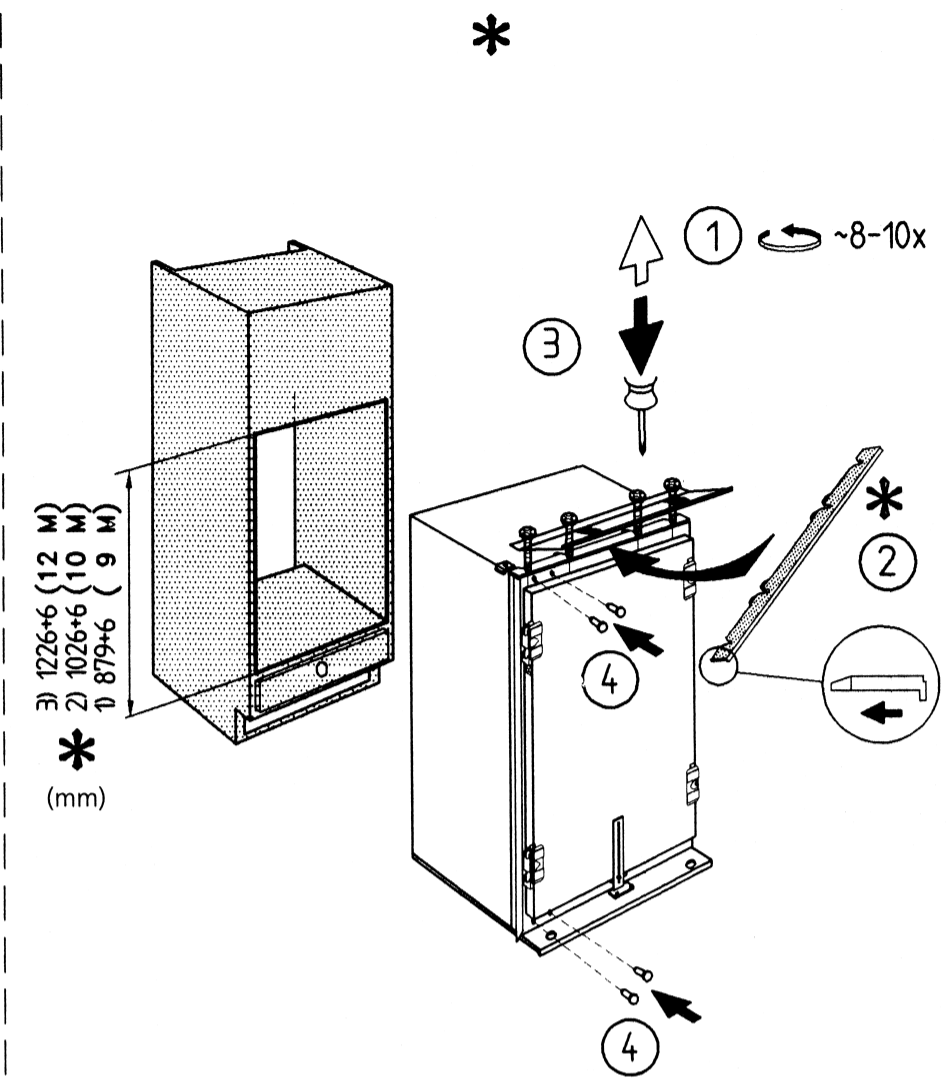

3

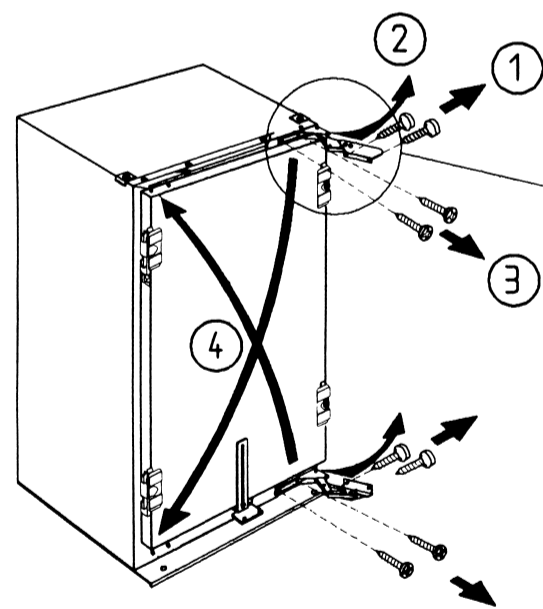

Türanschlagwechsel vor dem Geräteeinbau

Change over door hinging before installation of appliance

Changement de côté des charnières de porte avant la mise en place de l'appareil

De draairichting van de deur wijzigen vóór het inbouwen

Il cambio della cerniera della porta prima del montaggio dell'apparecchio

4

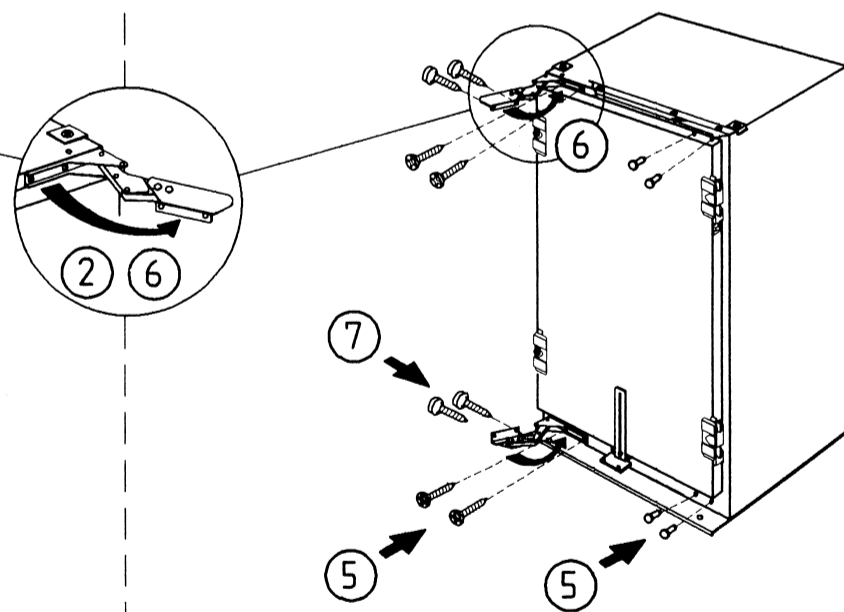

5

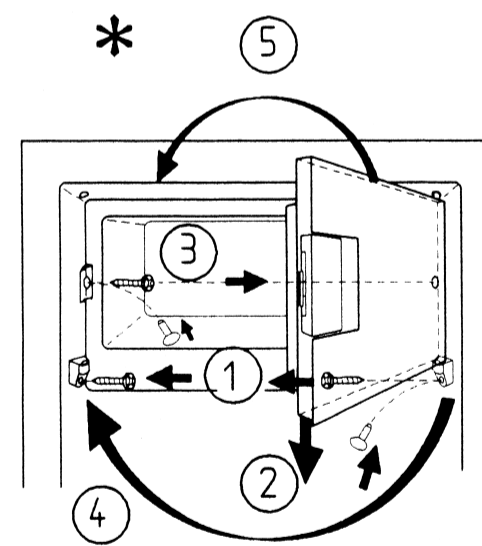

Bei Türanschlagwechsel auch Sternfachtür wechseln

Change over of star compartment flap

Inversion de la droite vers la gauche du portillon du compartiment

Verwisselen van de draairichting van de sterrenvriesvakdeur

Reversibilità della porta comparto congelatore

6

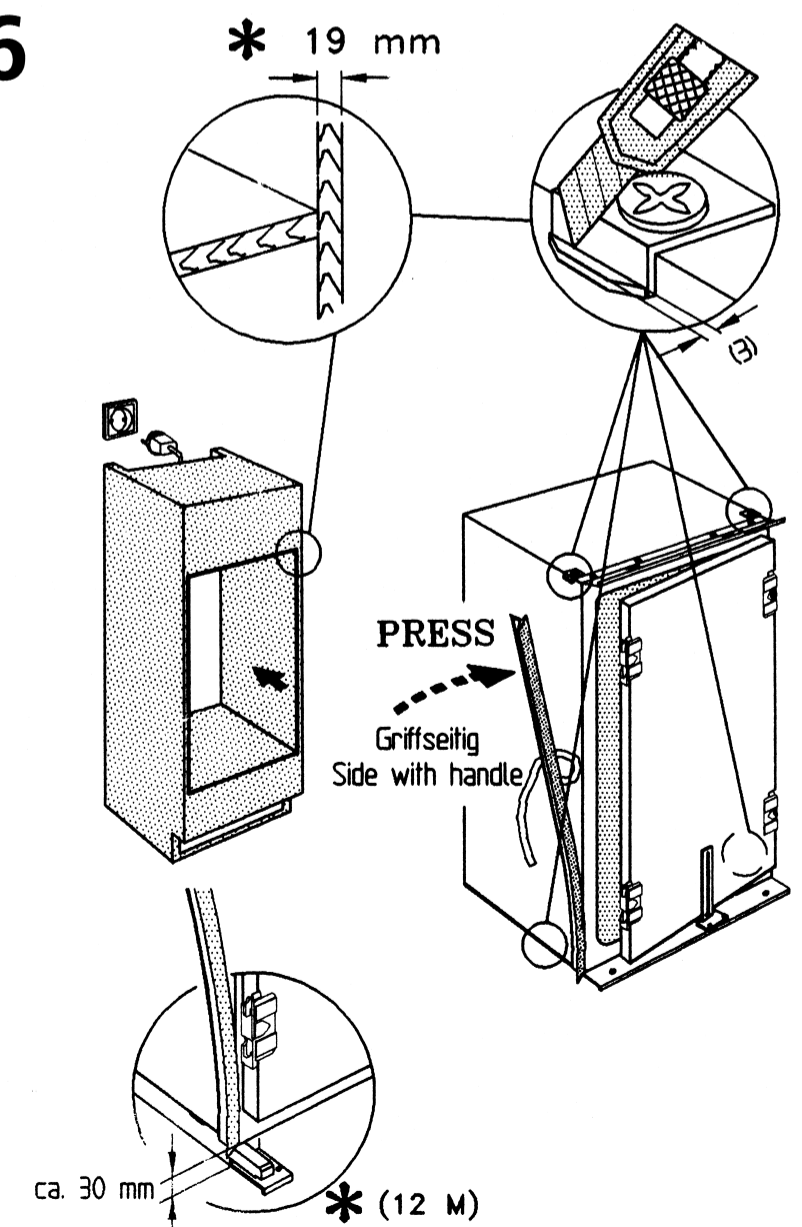

7

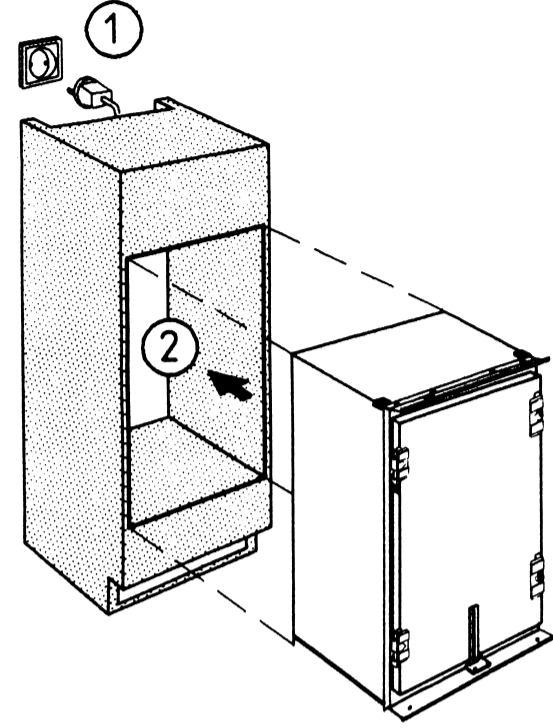

8

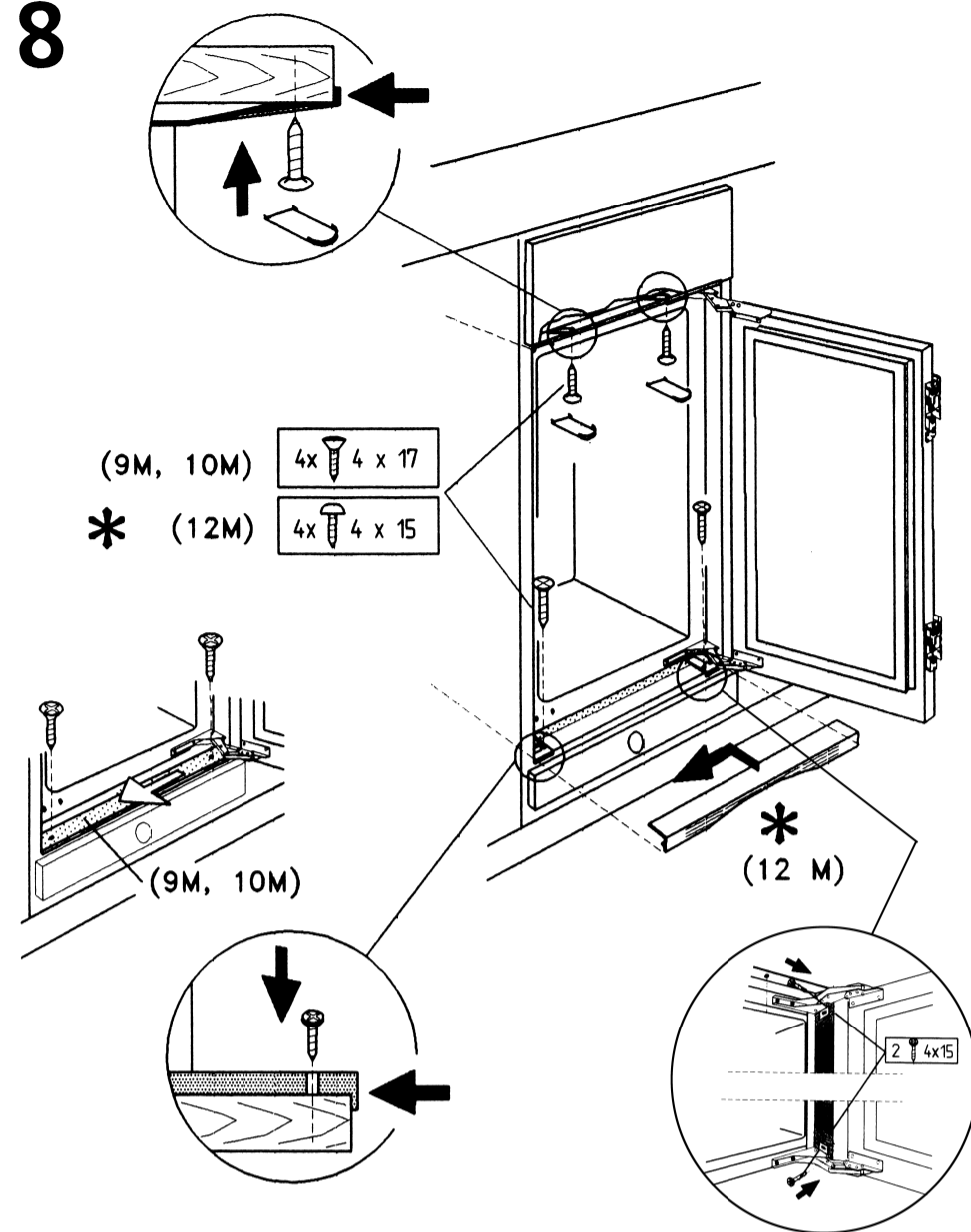

9

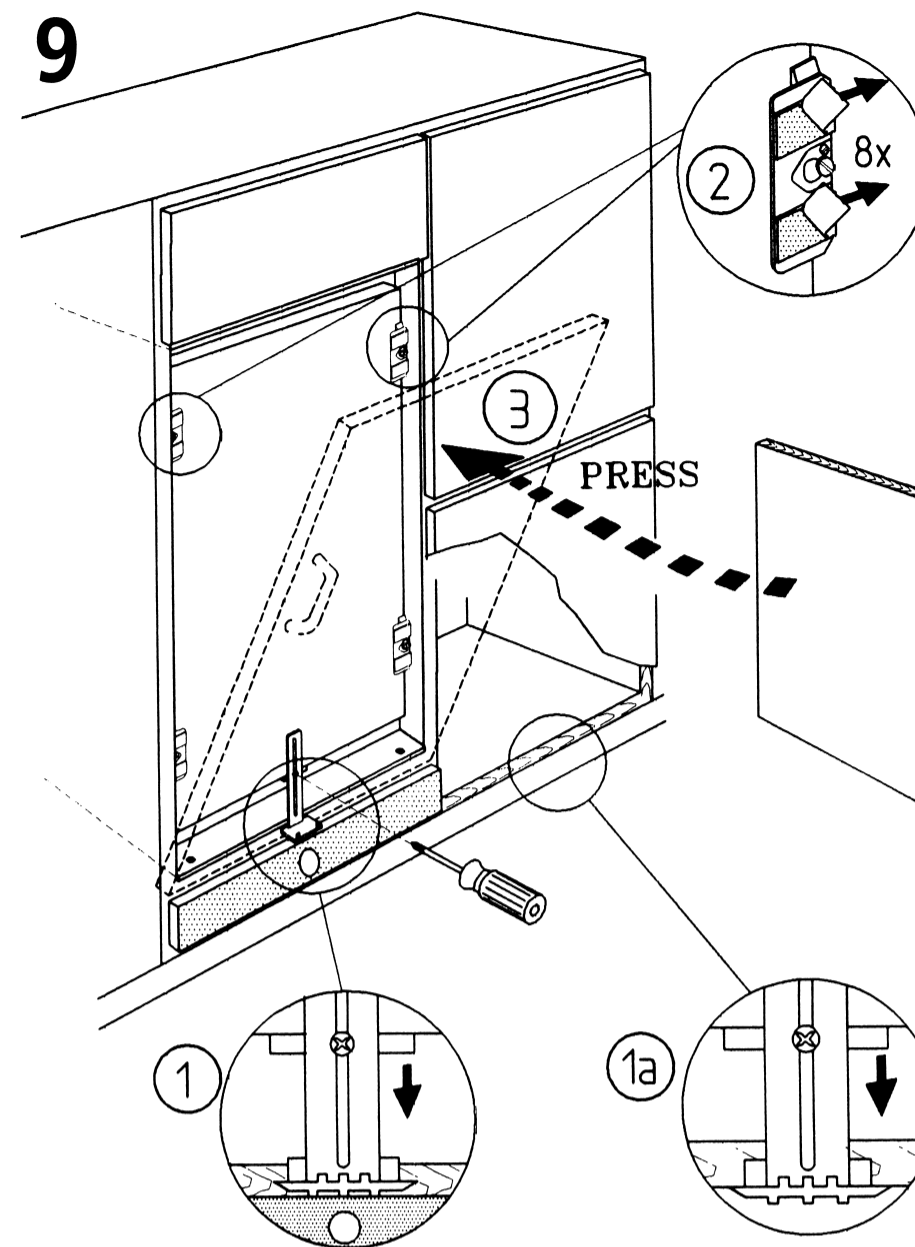

10

(9M,10M) 8x 4 x 17
 *(12M) 8x 4 x 15

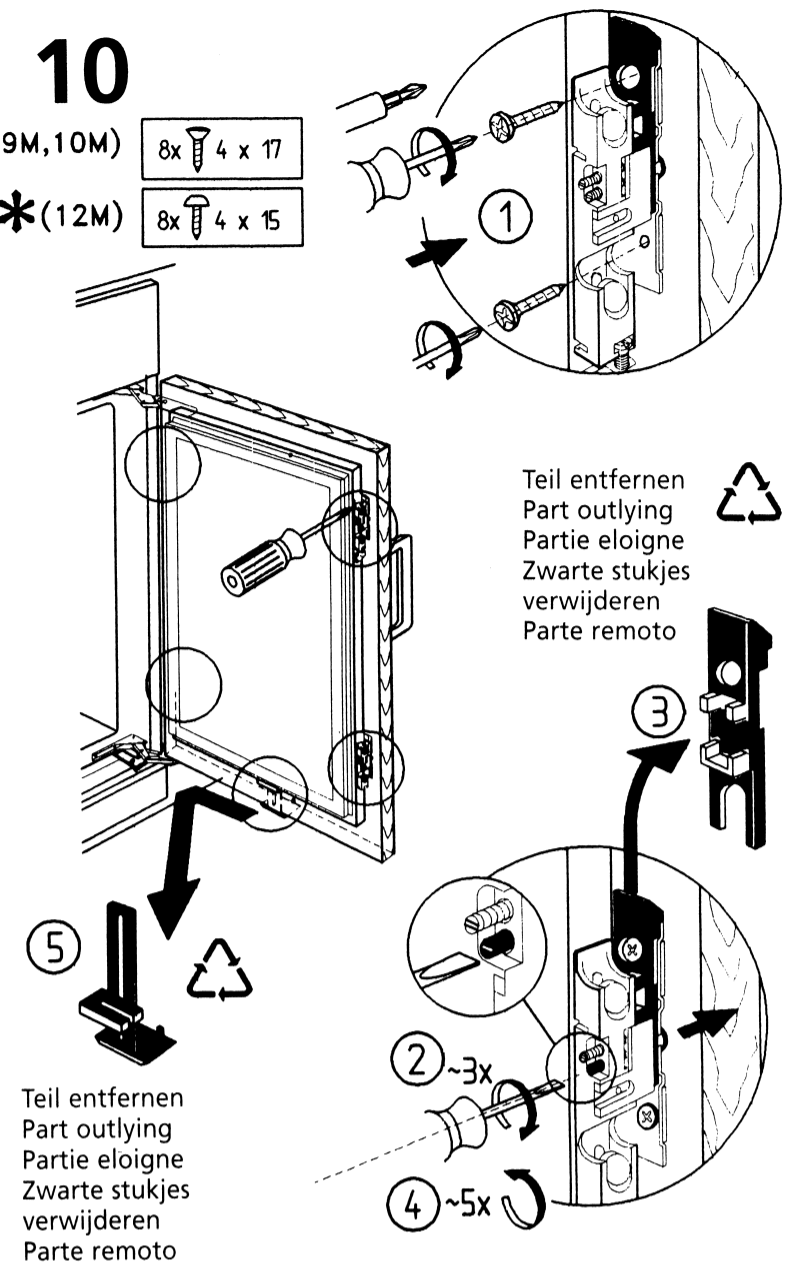

11

Möbeltür justieren
 Adjust wooden door
 Centrage de la porte de meuble
 Meubeldeur richten
 Allineamento la porta del mobile

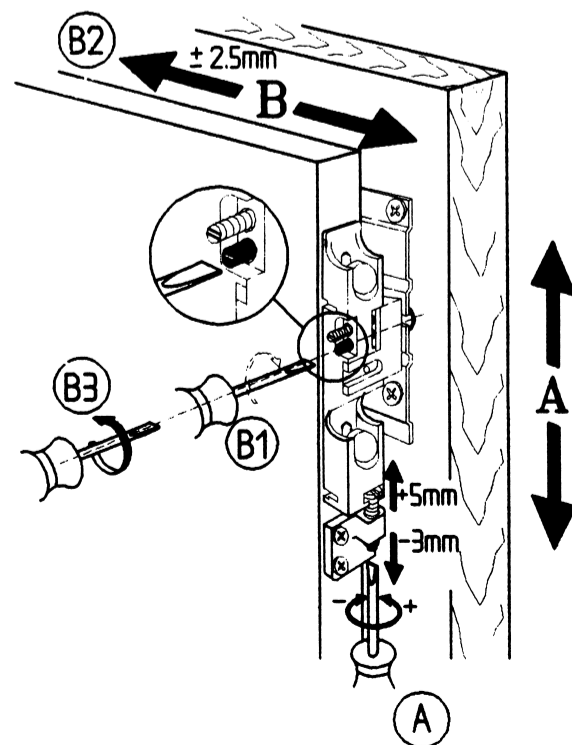

12

PRÜFEN
 CHECK
 CONTROLER
 CONTROLEREN
 CONTROLLARE

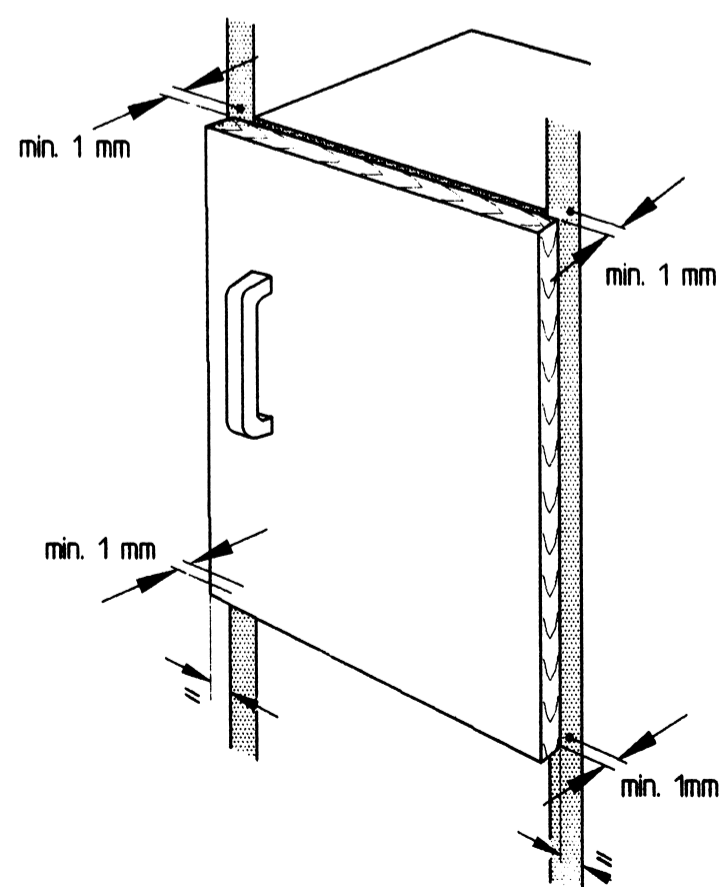

13

Möbeltür bei Bedarf nachjustieren
 Readjust if necessary
 Resserrer au besoin
 Indien noodzakelijk nastellen
 Se necessario, regolare

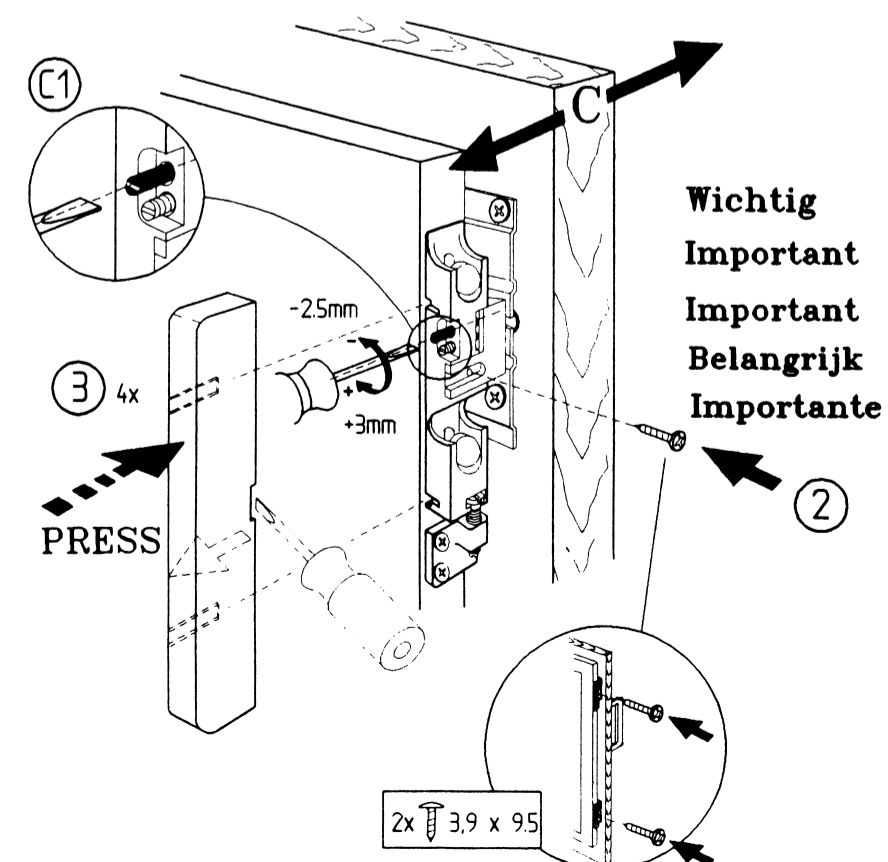

14

*(12 M)

Nur für geteilte Möbeltür
 Only for wooden door realised in two pieces
 Uniquement pour portes a plusieurs éléments
 Alleen voor dubbele meubeldeur
 Solo per portinr in legno realizzate in due pezzi

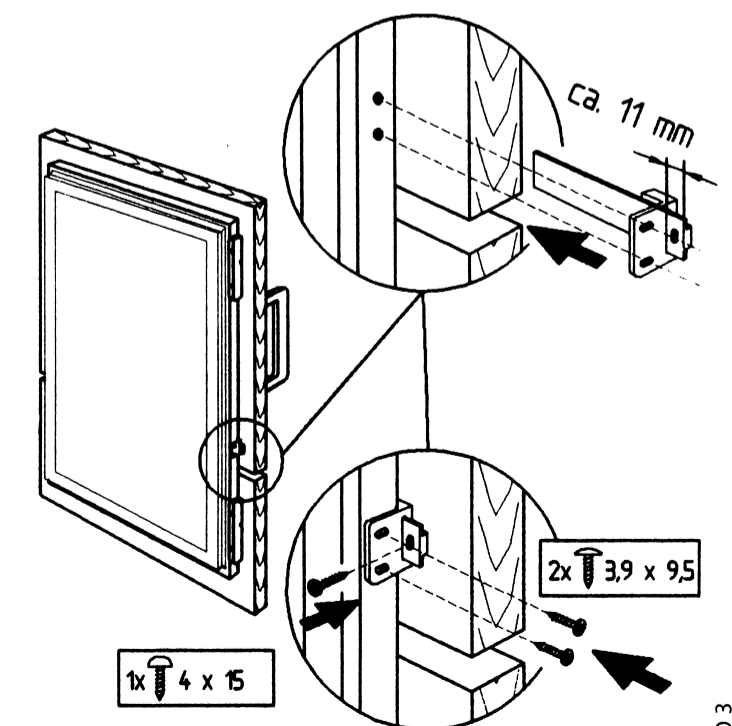

Congratulations!

This appliance offers you top technical features combined with maximum comfort and performance.

This new appliance is designed to the highest technical standards. Your appliance is equipped with energy-saving devices that allow you to behave in an environment-friendly way.

Good reading and

Thanks!



“Warning - this appliance must be earthed”

Fuse replacement.

If the mains lead of this appliance is fitted with a BS 1363A 13 amp fused plug, to change a fuse in this type of plug use an A.S.T.A. approved fuse to BS 1362 type and proceed as follows:

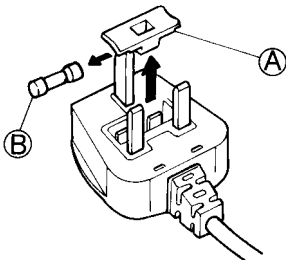

1. Remove the fuse cover (A) and fuse (B).
2. Fit replacement 13A fuse into fuse cover.
3. Refit both into plug.

Important: The fuse cover must be refitted when changing a fuse and if the fuse cover is lost the plug must not be used until a correct replacement is fitted.

Correct replacement are identified by the colour insert or the colour embossed in words on the base of the plug.

Replacement fuse covers are available from your local electrical store.

Connection to a rewireable plug

If the fitted plug is not suitable for your socket outlet, then it should be cut off and disposed of in order to avoid a possible shock hazard should it be inserted into a 13A socket elsewhere.

A suitable alternative plug should then be fitted to the cable.

The wires in this mains lead are coloured in accordance with the following code;

BLUE - “NEUTRAL” (“N”)

BROWN - “LIVE” (“L”)

GREEN AND YELLOW - “EARTH” (“E”)

1. The GREEN AND YELLOW wire must be connected to the terminal in the plug which is marked with the letter “E” or by the Earth symbol 4 or coloured green or green and yellow.
2. The BLUE wire must be connected to the terminal which is marked with the letter “N” or coloured black.
3. The BROWN wire must be connected to the terminal which is marked with the letter “L” or coloured red.

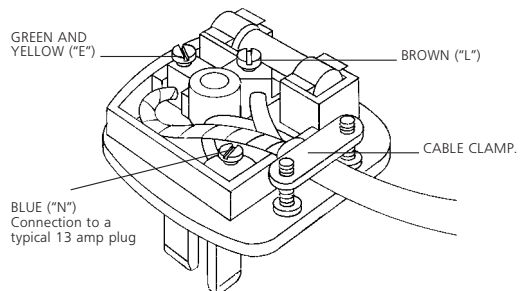

For the Republic of Ireland only

The information given in respect of Great Britain will frequently apply, but a third type of plug and socket is also used, the 2-pin, side earth type. In this case, the wire which is coloured GREEN AND YELLOW must be connected to the EARTH contact, and the other two wires to the two pins, irrespective of colour. The supply to the socket must be fitted with a 16 amp fuse.

DESCRIPTION OF THE APPLIANCE	Page 14
CONTROLS	Page 15
BEFORE USING THE APPLIANCE	Page 16
PRECAUTIONS AND GENERAL SUGGESTIONS	Page 16
HOW TO USE THE REFRIGERATOR COMPARTMENT	Page 17
HOW TO USE THE FREEZER COMPARTMENT	Page 18
HOW TO DEFROST AND CLEAN THE APPLIANCE	Page 19
TROUBLE-SHOOTING GUIDE	Page 19
AFTER-SALE SERVICE	Page 20
INSTALLATION	Page 20

DESCRIPTION OF THE APPLIANCE

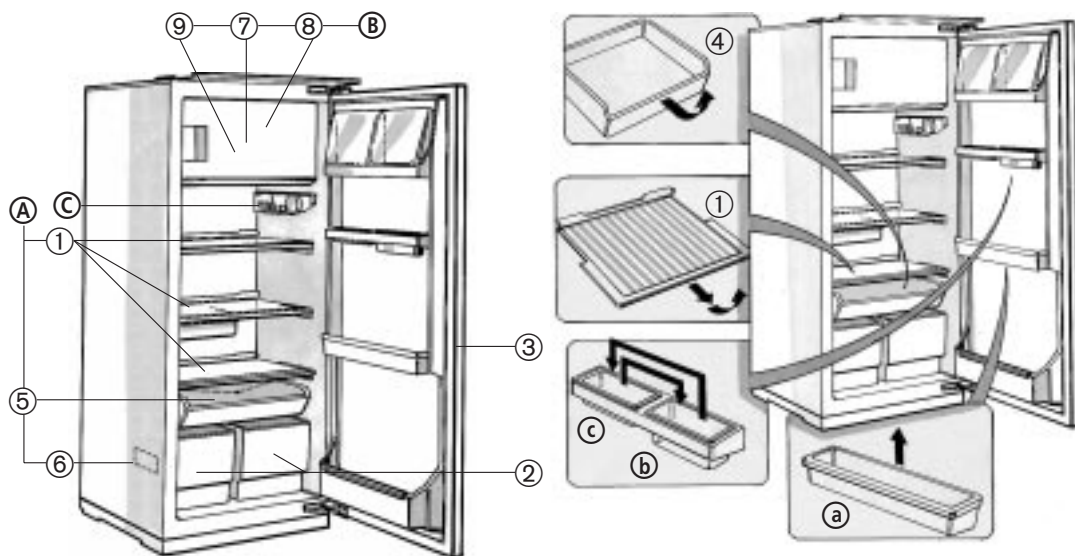

A) Refrigerator Compartment

(for storing fresh food)

1. Shelves (partially adjustable in height)
2. Fruit and vegetables drawers
3. Inside of the door with (if available):
 - a. Adjustable containers
 - b. Door box - top
 - c. Door box - bottom
4. Pull-out drawer (telescopic)
5. Defrost water run-off
6. Rating plate

B) Freezer Compartment (if available)

(with the ❄️ or ❄️❄️❄️ symbol, for freezing and/or storing fresh and frozen food, storing deep-frozen food and making ice cubes).

7. Freezer rack (not shown in the drawing, if available).
8. Freezing section
9. Ice cube trays

C) Control unit

CONTROLS

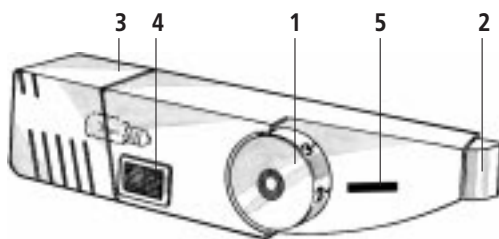

1. Thermostat knob
2. Light switch
3. Light shield
4. Pilot light switch: press the **pilot light switch** (if available) only when room temperature drops below 16°C - and / or 12 hours before freezing.
(see Instructions for Use).
turn the switch off after its utilization!
5. Setting mark

BEFORE USING THE APPLIANCE

- After unpacking, make sure that the appliance is undamaged and that the door closes tightly. Any damage must be reported to your retailer within 24 hours after delivery of the appliance.
- **Wait at least 2 hours without moving the appliance before connecting it to the power supply.**
- The appliance is built with recyclable material. Follow local disposal regulations.
- Make sure appliance installation and electrical connection are carried out by a qualified technician according to the Manufacturer's instructions and local safety regulations.

PRECAUTIONS AND GENERAL SUGGESTIONS

- Use the refrigerator compartment only for the storage of fresh food and the freezer compartment only for the storage of frozen food, the freezing of fresh food and to make ice cubes.
- Do not cover or close the air vents.
- Do not store liquids in glass containers. Glass containers holding liquids can burst in the freezer.
- Do not eat ice cubes or ice lollies immediately after taking them out of the freezer. Risk of "cold" burns.
- Before cleaning or servicing, always unplug the appliance or switch the power supply off.
- Do not allow children to play or hide inside the freezer: risk of becoming trapped inside and suffocating.
- If the appliance is to be scrapped, make it unusable by cutting off the power cord.
- Dispose of the appliance at an authorised collection centre for refrigerant gas.
- Do not ingest the contents of the ice packs!

Declaration of conformity

- This appliance is designed to store food products and conforms to EEC directive n.89/109.
- The appliance has been tested for leaks and it conforms to VBG 20 safety standards for refrigerating units.
- Perform electrical connection, installation and assembly exactly as indicated by the manufacturer. If you are in doubt, call a qualified technician. The electrical system in your home must conform to the electrical supply data shown on the rating plate.
- All repairs or service operations must be carried out by a qualified technician.

Information

- This appliance is free of CFC's (refrigerant circuit contains R134a) or free of HFC's (refrigerant circuit contains R600a - Isobutane). For more details, please refer to the rating plate on the appliance.

For appliances with Isobutane (R600a)

- The refrigerant Isobutane is a natural gas of high environmental compatibility but which is inflammable. Therefore, it is essential to ensure that the ducts of the refrigerant circuit do not get damaged.

HOW TO USE THE REFRIGERATOR COMPARTMENT

This appliance is either a refrigerator, or a refrigerator with a **(****)** compartment, or a refrigerator with a **(***)** compartment.

The appliance has been designed to run at a room temperature ranging from +10°C to +38°C. For appliances with a **(****)** compartment without pilot light (4), from +16°C to +38°C.

① Getting started

After the appliance has been connected to the power supply, the inside light turns on when the refrigerator door is opened and the thermostat knob is not on position ●. After the temperature has been set, as described below, the appliance is ready for use.

② To set the temperature:

- Thermostat knob (1) on ●: no cooling and light off.
- Thermostat knob (1) on 1: minimum cooling
- Thermostat knob (1) on 3-4: average cooling
- Thermostat knob (1) on 7: maximum cooling

Important:

- Press the pilot light switch (4) when you freeze food and/or when room temperature drops **below 16°C**. The pilot light (4) turns on.
- When room temperature rises **above 16°C** turn the pilot light switch (4) off.
- Inside temperatures are affected by the position of the appliance, room temperature and frequency of door openings. Thermostat setting (1) may have to be changed depending on these factors.

How to store food in the refrigerator compartment

③ We suggest to arrange food as shown in the figure on the side:

1. Cooked food
2. Dairy products, tinned products, cheese, butter
3. Fish, meat
4. Sliced food
5. Fruit and vegetables
6. Small tins, eggs
7. Tubes, small tins
8. Sausage
9. Bottles

Notes:

- Do not store food in an open container since it would dry up.
- Do not store food that is still warm in the refrigerator compartment.
- Make sure that air circulates freely between stored food.

Defrosting of the refrigerator compartment is completely automatic.

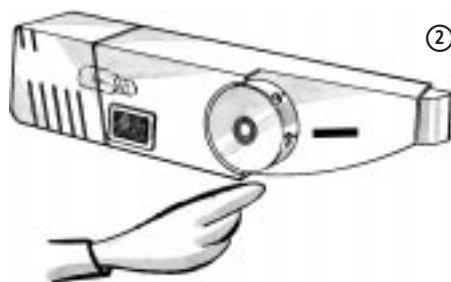

HOW TO USE THE FREEZER COMPARTMENT

Only for appliances with ******* compartment or ****** compartment:

④ In the ******* freezing compartment it is possible to store frozen food.

In the ****** freezing compartment it is possible to store food for several months. Furthermore, it is possible to freeze foods. The quantity in kilos of fresh food that can be frozen within 24 hours is indicated on the plate (6).



Freezing of foods

⑤ Press the pilot light switch (4) 12 hours before introducing the food. The pilot light turns on.

- Set the thermostat (1) 12 hours before introducing the food.
- Remove the rack (if available) (7) from the ****** compartment.
- For freezing put the food in the middle of the ****** compartment (at the back).



Important:

- Wrap and seal food in aluminium foil, cling film, air- and watertight plastic bags, polyethylene containers with lids, containers suitable for freezers.

When buying frozen food, make sure that:

- Wrapper or package is intact as the food may deteriorate. If it bulges or has spots of moisture on it, it means that it has not been stored in adequate conditions and that the contents may have started to thaw.
- Always use thermal bags or cold boxes for transport.
- Frozen food should always be purchased last.
- When at home, immediately store it in the freezer.
- Any food, even if partially thawed, cannot be re-frozen but must be eaten within 24 hours.
- Any rise in temperature of frozen food should be avoided or kept as short as possible. Frozen food should not be kept beyond the date indicated on the package.
- Always follow the instructions on how to store frozen food written on the packaging.

Making ice cubes



- Fill the ice cube trays (9) 3/4 full of water and place them on the bottom of the freezer compartment.
- Use the handle of a spoon to free the ice cube trays if they are stuck.

Do not use sharp or pointed tools.

HOW TO DEFROST AND CLEAN THE APPLIANCE

Before carrying out any cleaning or maintenance, always unplug the appliance.

You should defrost the freezer compartment when frost build-up reaches 3 mm in thickness.

- Remove all food from the  or  compartment and turn the thermostat knob to ●.
 - Wrap the food in paper or a blanket and put it in a cool place.
 - Periodically clean the inside of the appliance with a sponge dampened in a solution of warm water and neutral pH detergent.
 - Rinse and dry.
 - Defrosting of the refrigerator compartment is completely automatic.
- ⑥ Regularly clean the defrost water run-off with a brush so that the defrost water will flow down unhindered. After having cleaned the appliance, plug it in.

Do not use abrasives.

Long vacation

- Empty the appliance.
- Unplug the appliance.
- Defrost and clean the inside.
- Leave the door open to prevent odour from setting in.



⑥

TROUBLE-SHOOTING GUIDE

1. The temperature is not cold enough

- Is the food preventing the door from closing properly?
- Is the thermostat on the correct setting?
- Is air circulation blocked?

2. The temperature in the refrigerator compartment is too cold

- Is the thermostat on the correct setting?

3. The appliance is excessively noisy

- Has the appliance been properly installed?
- Do the pipes on the back touch and rattle?
- Gurgling noises inside the refrigerating circuit are normal.

4. The appliance does not work

- Is there a power failure?
- Is the plug properly inserted in the socket?
- Has the fuse blown?
- Is the appliance switched on?

5. There is water on the bottom of the refrigerator compartment

- Is the thermostat on the correct setting?
- Is the defrost water run-off clogged?

6. The inside light does not work ⑦.

First check point 4, then:

- Unplug the appliance.
- 1. Press the light shield (3).
- 2. Remove the light shield (3).
- Replace the bulb (220 ÷ 240 V, 15 W).



⑦

AFTER-SALE SERVICE

- ⑧ If the freezer does not work correctly even after you have consulted the trouble shooting guide, contact after sales Service.



⑧

INSTALLATION

- ⑨ Do not install the appliance close to any heat source. High room temperatures, direct sunlight, or location near heating or stoves increase the power consumption and should be avoided. If it is not possible to avoid placing the appliance next to a source of heat, note that the following spacings should be maintained:

to coal oil ovens or heaters 30 cm

to electric cookers/Hotplates 3 cm

- The appliance must be placed in a dry and well-ventilated room.
- Clean the interior (see "DEFROSTING AND CLEANING THE APPLIANCE").
- Assemble the accessories.
- Check the efficiency of the door seal, especially after the appliance has been built in and the door opening direction has been changed.



⑨

Electrical connection

- Check that the voltage shown on the rating plate corresponds to the voltage in your home.
- The appliance must be earthed in accordance with the law. The Manufacturer cannot be held liable for any injury to persons or damage to property resulting from the failure to comply with this requirement.
- If the appliance plug and the wall socket are incompatible, the socket must be replaced by a qualified electrician.
- Do not use adapters, multiple sockets or extension cables.