

# **INSTRUCTIONS FOR USE**

**PRODUCT DESCRIPTION**

**CONTROLS**

**BEFORE USING THE APPLIANCE**

**SAFEGUARDING THE ENVIRONMENT**

**PRECAUTIONS AND GENERAL  
RECOMMENDATIONS**

**HOW TO OPERATE THE REFRIGERATOR  
COMPARTMENT**

**HOW TO OPERATE THE FREEZER  
COMPARTMENT**

**HOW TO DEFROST AND CLEAN THE  
APPLIANCE**

**TROUBLESHOOTING GUIDE**

**AFTER-SALES SERVICE**

**INSTALLATION**

**ELECTRICAL CONNECTION**

# PRODUCT DESCRIPTION

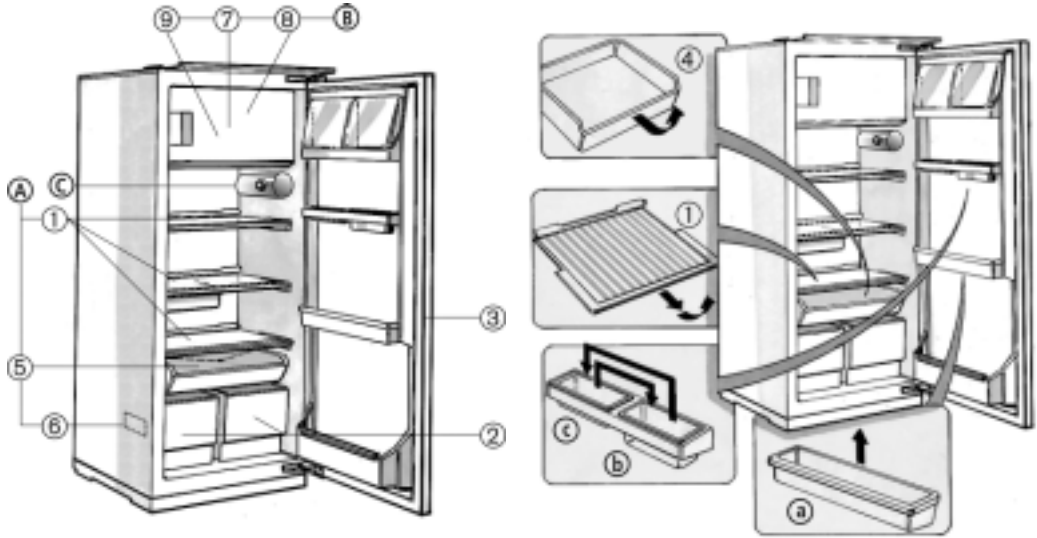

## A) Refrigerator compartment (for storage of fresh food and beverages)

1. Shelves (partly height adjustable)
2. Crisprs
3. Refrigerator inner door with:  
(if supplied)
  - a. Adjustable door trays
  - b. Top door tray
  - c. Bottom door tray
4. Drawer (telescopic extraction)
5. Pull-out defrost water drain
6. Rating plate

## B) Freezer compartment (if supplied) (marked with the symbol for storing fresh food, frozen food and making ice cubes)

7. Grid (not shown in the figure, if available)
  8. Freezer section
  9. Ice cube trays
- ## C) Controls

# CONTROLS

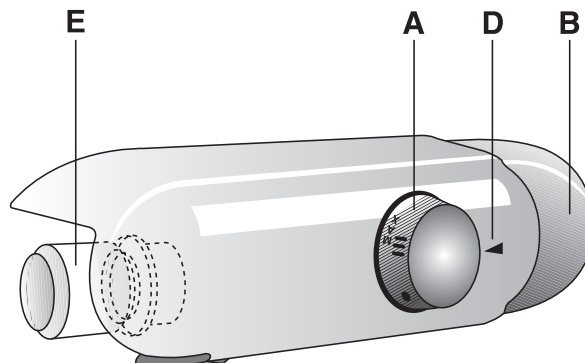

- A. Thermostat knob
- B. Light switch

- D. Thermostat control reference
- E. Light bulb (max 15 W)

# BEFORE USING THE APPLIANCE

- Your new appliance is designed exclusively for domestic use

**To get the most out of your new appliance, read the user handbook thoroughly. The handbook contains a description of the appliance and useful tips for storing food. Keep this handbook for future consultation.**

1. After unpacking, make sure that the appliance is undamaged and that the door closes properly. Any damage must be reported to your dealer within 24 hours after delivery of the appliance.
2. Wait at least two hours before switching the appliance on in order to ensure the refrigerant circuit is fully efficient.
3. Installation of the appliance and electrical connections must be carried out by a qualified electrician, in accordance with the manufacturer's instructions and local safety regulations
4. Clean the inside of the appliance before using it.

# SAFEGUARDING THE ENVIRONMENT

## 1. Packing

The packaging material is entirely recyclable, and marked with the recycling symbol. Follow local regulations for scrapping. Keep the packaging materials (plastic bags, polystyrene parts, etc.) out of reach of children, as they are potentially dangerous.

## 2. Scrapping

The appliance is manufactured using recyclable material.

This appliance is marked according to the European directive 2002/96/EC on Waste Electrical and Electronic Equipment (WEEE). By ensuring this product is disposed of correctly, you will help prevent potential negative consequences for the environment and human health, which could otherwise be caused by inappropriate waste handling of this product.

The symbol  on the product, or on the documents accompanying the product, indicates that this appliance may not be treated as household waste. Instead it shall be handed over to the applicable collection point for the recycling of electrical and electronic equipment.

Before scrapping, make the appliance unusable by cutting off the power cable and removing the doors and shelves so that children cannot easily climb inside the appliance.

Disposal must be carried out in accordance with local environmental regulations for waste disposal. Deliver the appliance immediately to an authorized dump; do not leave it unattended even for a few days, since it is potentially dangerous for children. For more detailed information about treatment, recovery and recycling of this product, please contact your local city office, your household waste disposal service or the shop where you purchased the product.

## Information:

This appliance does not contain CFCs (replaced with R134a) or HFCs (replaced with R600a).

Appliances with Isobutane (R600a): isobutane is a naturally occurring, low environmental impact gas. Caution is required, however, because isobutane is flammable. Therefore, it is essential to ensure that refrigerant pipelines are not damaged.

## Declaration of conformity

- This appliance is designed to store food and is manufactured in conformity with European Directive 90/128/EEC, 02/72/EEC and Regulation (EC) No. 1935/2004



- This appliance is designed, manufactured, and retailed in compliance with:
  - the safety objectives of the Low Voltage Directive 73/23/EEC;
  - the protection requirements of the "EMC" Directive 89/336/EEC, amended by Directive 93/68/EEC.
- The electrical safety of the appliance can only be guaranteed if the product is connected to an approved earth connection.



# PRECAUTIONS AND GENERAL RECOMMENDATIONS

- Use the refrigerator compartment only for storing fresh food and beverages and use the freezer compartment only for storing frozen food, freezing fresh food and making ice cubes.
- After installation, make sure that the appliance is not standing on the power supply cable.
- Do not store glass containers with liquids in the freezer since they may burst.
- Do not eat ice cubes or ice lollies immediately after taking them out of the freezer since they may cause cold burns.
- Before servicing or cleaning the appliance, unplug it from the mains or disconnect the electrical power supply.
- Make sure that the appliance is not near a heat source.
- Do not store or use gasoline or other flammable vapours and liquids in the vicinity of this or any other appliance. The fumes can create a fire hazard or explosion.
- To ensure proper ventilation leave a space on both sides and at the top of the refrigerator.
- Ensure that the vent outlets on the appliance casing or housing unit are unobstructed in order to allow correct air circulation.
- All appliances equipped with an ice maker or water dispenser must be connected to a mains water supply that delivers potable water only (with water pressure between 1.7 and 8.1 bar (25 and 117 PSI)). Ice makers and/ or water dispensers not directly connected to a mains water supply must be filled with potable water only.
- Install and level the appliance on a floor strong enough to take its weight and in an area suitable for its size and use.

- Install the appliance in a dry and well-ventilated place. The appliance is set for operation at specific ambient temperature ranges, according to the climatic class indicated on the data plate: The appliance may not work properly if it is left for a long period at a temperature above or below the indicated range.

Climatic class	Amb. T. (°C)	Amb. T. (°F)
SN	From 10 to 32	From 50 to 90
N	From 16 to 32	From 61 to 90
ST	From 18 to 38	From 64 to 100
T	From 18 to 43	From 64 to 110

- Be careful not to damage the floors when you move the appliance (e.g. parquet flooring).
- Do not use mechanical devices or any means other than those recommended by the manufacturer to speed up the defrosting process.
- Do not damage the refrigerant circuit.
- Do not use electrical appliances inside the freezer compartments, unless such appliances are specifically recommended by the manufacturer.
- This appliance is not designed for use by young children or the infirm.
- To avoid the risk of children being trapped and therefore suffocating, do not allow them to play or hide inside the appliance.
- The power cable may only be replaced by an authorized person.
- Do not use extension leads or adapters.
- It must be possible to disconnect the appliance from the mains by unplugging it or by means of a two-pole switch fitted upline of the socket.
- Ensure that the voltage indicated on the appliance data plate corresponds to the domestic supply voltage
- Do not swallow the contents (non-toxic) of the ice packs (if provided).

# HOW TO OPERATE THE REFRIGERATOR COMPARTMENT

This appliance is a refrigerator with a  star freezer compartment.

OR is a refrigerator with a  star freezer compartment.

Optimal appliance performance is obtained at ambient temperatures between +10°C and +38°C.

## ① Switching on the appliance

Once the power plug is inserted in the mains socket, unless the thermostat (1) is set to symbol ● the inside light switches on each time the door is opened.

Once the temperature has been set – see next chapter – the appliance is ready for use.

## Adjusting the temperature

- To adjust the temperature in the compartment, turn the thermostat control knob:
  - to lower numbers 1-2/MIN for the **LEAST COLD** internal temperatures;
  - to 3-4/MED for a **MEDIUM** temperature;
  - to 5-7/MAX for the **COLDEST** temperature.

Thermostat setting on ●: no operation, no light.

### Note:

The ambient air temperature, frequency of door opening and the position of the appliance can affect internal temperatures. These factors must be taken into account when setting the thermostat.

### Important

- Thermostat adjustment (1) will depend on where the appliance is installed, ambient temperature and frequency of door opening.

## How to use the refrigerator compartment:

③ Position the food as illustrated in the figure:

1. Cooked food
2. Dairy products, preserves, cheese, butter
3. Fish, meat
4. Sliced cold meat
5. Fruit, vegetables, salad
6. Small jars, eggs
7. Tubes, small jars
8. Small bottles
9. Bottles

### Note:

- Cover food to prevent it drying out.
- Hot food must be allowed to cool properly before being placed in the refrigerator.
- Make sure sufficient space is left for air to circulate around the food.

Defrosting of the refrigerator compartment is completely automatic.



# HOW TO OPERATE THE FREEZER COMPARTMENT

Only for  or  appliances:

④ Appliances with the symbol  can be used to store already frozen food.

Appliances with the symbol  can be used to store food for months and also to freeze food. The amount of fresh food (in kg) that can be frozen in 24 hours is indicated on the appliance rating plate (see paragraph "Product description", point 6).

## Freezing food

- Set the thermostat knob (1) to 3-4.
- Arrange the food to be frozen centrally in the  freezer compartment.
- Avoid contact between already frozen food and food that has yet to be frozen (approx. 20 mm distance).
- After 24 hours turn the thermostat knob (1) back to the normal position.

## Important:

Wrap and seal the food in:

- Aluminium foil, cling film, watertight plastic bags, polythene containers with lids or special freezer containers.

## When purchasing frozen food products:

- Ensure that the packaging is not damaged (frozen food in damaged packaging may have deteriorated). If the package is swollen or has damp patches, it may not have been stored under optimal conditions and defrosting may have already begun.
- Transport products in a thermally insulated cool bag.
- When shopping, leave frozen food purchases until last.
- Once at home, place the frozen foods immediately in the freezer.
- If food has defrosted even partially, do not re-freeze it. Consume within 24 hours.
- Avoid subjecting foods to temperature variations. Observe the "best before" date on the package.
- Always observe the storage information on the package.

## Making ice cubes



- Fill the ice cube trays (9)  $\frac{3}{4}$  with water and place them at the bottom of the freezer compartment.
- Use a spoon handle to remove ice cube trays which stick to the compartment.

**Do not use sharp or pointed instruments.**



# HOW TO DEFROST AND CLEAN THE APPLIANCE

Before carrying out any maintenance or cleaning operations, unplug the appliance from the mains socket. Defrost the freezer compartment when the ice on the walls reaches a thickness of 3 mm.

- Remove foodstuffs from the  or  freezer and turn the thermostat knob to ●.
  - The frozen food must be wrapped in sheets of newspaper (or a cover) and kept in a cool place.
  - Clean the freezer compartment using a sponge dampened in a solution of lukewarm water and/or neutral detergent.
  - Rinse and dry carefully.
  - Defrosting of the refrigerator compartment is fully automatic.
- ⑤ Clean the defrost water drain outlet regularly in order to ensure that defrost water is removed correctly.

After cleaning, reconnect the appliance to the power supply.

**Do not use abrasive products.**

**Prolonged disuse.**

- Empty the compartments.
- Disconnect the appliance from the mains power supply.
- Defrost and clean.
- Leave the doors open to prevent formation of unpleasant odours.



# TROUBLESHOOTING GUIDE

When you hear these noises

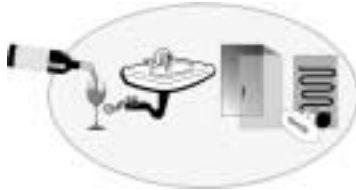
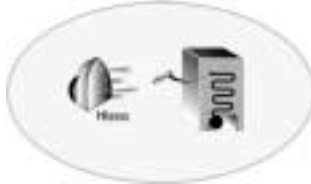

..your appliance is alive!!!

- 1. Temperature inside the compartments is not low enough.**
  - Is food preventing the doors from closing properly?
  - Is the thermostat setting correct?
  - Are the air circulation vents blocked?
- 2. Temperature inside the refrigerator compartment is too low.**
  - Is the thermostat setting correct?
- 3. The appliance is excessively noisy.**
  - Has the appliance been installed correctly?
  - Are the pipes at the back touching or vibrating?
  - It is normal to hear the noise of the refrigerant liquid in circulation.
- 4. The appliance is not working?**
  - Is there a power failure?
  - Is the plug properly inserted in the socket?
  - Has the fuse blown?
  - Is the power cord damaged?
- 5. Water collects at the bottom of the refrigerator compartment.**
  - Is the thermostat setting correct?
  - Is the defrost water drain blocked?
- 6. The inside light is not working. ⑥ Perform the checks for point 4, and then:**
  - Disconnect the appliance from the mains power supply.
  - If necessary replace the bulb with a new one (220 ÷ 240V, 15 Watt).
  - Removing the light bulb: Unscrew the bulb anticlockwise as shown in the figure



⑥



# AFTER-SALES SERVICE

## Before contacting After-Sales Service:

1. See if you can solve the problem yourself with the help of the "Troubleshooting guide".
2. Switch the appliance on again to see if the problem has been solved. If it has not, disconnect the appliance from the power supply and wait for about an hour before switching on again.
3. If the problem persists after this course of action, contact After-sales Service.

## Specify:

- the nature of the problem,
- the model,
- the Service number (the number after the word SERVICE on the rating plate on the inside of the appliance),
- your full address,
- your telephone number and area code.

**SERVICE** 0000 000 00000



## Note:

The direction of door opening can be changed. If this operation is performed by After-sales Service it is not covered by the warranty.

# INSTALLATION

- ⑧ Install the freezer away from heat sources. Installation in a hot environment, direct exposure to the sun or installation near heat sources (heaters, radiators, cookers) will increase power consumption and should therefore be avoided. If this is not possible, the following minimum distances must be respected:  
30 cm from coal or paraffin stoves  
3 cm from electric stoves.
- Install the appliance in a dry, well-ventilated place.
  - Clean the interior (see "How to defrost and clean the appliance").
  - Fit the accessories.
  - Check the door seal is not damaged or deformed, especially after installation or reversal of door opening.

## Electrical connection

- Ensure that the voltage indicated on the appliance rating plate corresponds to the domestic supply voltage.
- Regulations require that the appliance is earthed. The Manufacturer declines all liabilities for injury to persons or damage to property resulting from failure to observe these regulations.
- If the plug and socket are not of the same type, have the socket replaced by a qualified electrician.
- Do not use extension cables, multiple sockets or adapters.



⑧

# ELECTRICAL CONNECTION

## 1) For Great Britain only

**Warning - this appliance must be earthed**

### Fuse replacement

If the mains lead of this appliance is fitted with a BS 1363A 13amp fused plug, to change a fuse in this type of plug use an A.S.T.A. approved fuse to BS 1362 type and proceed as follows:

1. Remove the fuse cover (A) and fuse (B).
2. Fit replacement 13A fuse into fuse cover.
3. Refit both into plug.

### Important:

The fuse cover must be refitted when changing a fuse and if the fuse cover is lost the plug must not be used until a correct replacement is fitted.

Correct replacement are identified by the colour insert or the colour embossed in words on the base of the plug.

Replacement fuse covers are available from your local electrical store.

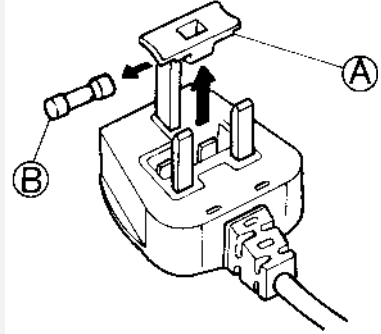

## 2) For the Republic of Ireland only

The information given in respect of Great Britain will frequently apply, but a third type of plug and socket is also used, the 2-pin, side earth type.

## 3) Socket outlet / plug (valid for both countries)

If the fitted plug is not suitable for your socket outlet, please contact Whirlpool Service for further instruction. Please do not attempt to change plug yourself. This procedure needs to be carried out by a qualified Whirlpool technician in compliance with the manufactures instructions and current standard safety regulations.