

WYZER⁵

www.mywyzer.com

Customer Support:
support@globewyze.com

Designed by GlobeWyze Inc., Richmond Hill, ON Canada.
Assembled in China.
Copyright 2009 GlobeWyze Inc. All rights reserved.
Wyzer, WYZER⁵ are trademarks or registered trademarks
of GlobeWyze Inc.

TABLE OF CONTENTS

INTRODUCTION TO WYZER ⁵	2
WYZER ⁵ PROFILES	2
CHARGING.....	3
USE.....	3
POWERING ON/OFF	3
PAIRING	4
VOLUME ADJUSTMENT.....	5
OPERATION AND INDICATION CHART	5
INDICATOR LIGHT CHART.....	6
TROUBLE SHOOTING	6
CAUTION.....	7
MAINTENANCE	7
TECHNICAL SPECIFICATIONS.....	8

INTRODUCTION TO WYZER⁵

The beauty of WYZER⁵ is expressed in the simplicity of its form factor outside, while employing the latest in the world chipset and components inside. When you wear the headset, it returns the favor by giving you comfort, quality conversation and functionality, expected in a classy brand.

Please read this manual carefully before using WYZER⁵. In addition, please keep your mobile phones' instruction manuals handy for reference.

BLUETOOTH TECHNOLOGY

What is Bluetooth technology?

Bluetooth technology enables devices to communicate without wires, using built-in radio transceivers, which operate on a globally available radio frequency to ensure worldwide compatibility. Your WYZER⁵ headset can communicate with other Bluetooth devices within a range of approximately 10 meters (33 ft).

NOTE. Bluetooth signals can be interfered by obstructions, such as a wall, body, etc.

How to use Bluetooth wireless headsets?

With Bluetooth technology, WYZER⁵ is able to connect with any Bluetooth enabled devices freely, for example, iPhone and Nokia N72. You can:

- Make calls with hands-free profile and adjust volume using your mobile phone.
- Reject calls via headset.
- Make calls with the voice-dialing function.

NOTE. To meet different user habits, WYZER⁵ supports both HSP (Headset Profile) and HFP (Hands-free Profile). Please refer to your user manual for more operation instruction.

WYZER⁵ PROFILES

1. Multi-Function Button (MFB) & Indicator Light
2. Charging socket
3. Speaker
4. Microphone
5. Ear-loop

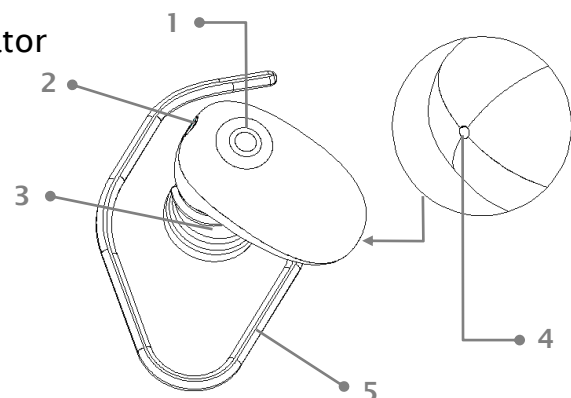

CHARGING

1. Please fully charge the headset before using.
2. While in use or in standby state, please charge the headset if you hear 1 alert tone every 10 seconds, along with red indicator light flashing every 5 seconds.
3. When the charger is plugged in, the red indicator light flashes twice and then shine steadily, meaning the headset has entered charging state. When the charging is complete, the red light turns blue

TIP. The headset can be charged via:

- a. Computer with its original USB charging cable plugged into computer's USB port;
- b. Wall plug with the USB cable into the wall charger.

NOTE. After fully charged, the battery offers:

- Talk time: approximately 3.5 hours
- Standby time: 85 hours

Battery life may vary depending on your phone settings and your usage pattern.

CAUTION. Do not charge the headset with non-original charger or charging cable. Any damage caused by non-Wyzer accessories will void the warranty.



USE

1. The headset is fit for wearing on either ear. Simply adjust the ear loop direction as shown in the diagram.
2. Firmly put the speaker into your ear.
3. Rotate the ear loop to turn the microphone in the direction of your mouth.

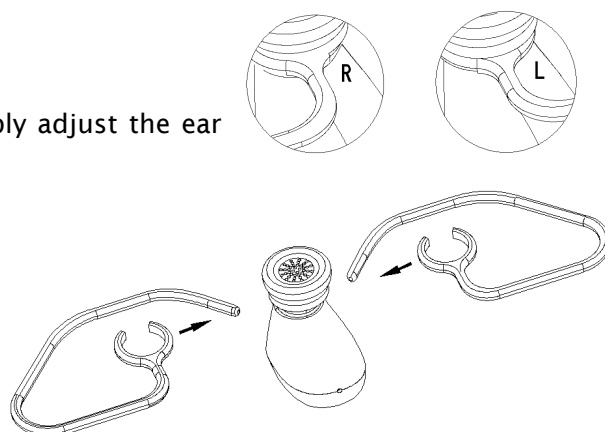

POWERING ON/OFF

Powering ON

1. Press and hold WYZER⁵ MFB for about 5 seconds.
2. Release as soon as the indicator lights (both blue and red) shine for 1 second. Now the headset has been turned on along with an indication tone and the flashing indicator light turns red.

NOTE. When the headset has not been connected to any Bluetooth devices, only the red indicator light flashes.

Powering OFF

1. When the headset is ON, press and hold its MFB for about 5 seconds.
2. Release the button when its indicator lights (both blue and red) shine for 1 second and then disappear along with indication tone. Now the headset has been turned off.

PAIRING

Please make sure your phone is Bluetooth-enabled before you start the pairing process. Follow your phone instructions. Place the phone and headset together (less than 1 meter) for smooth pairing.

Pairing with One Phone

1. Turn on both the headset and the phone.
2. Hold the headset's MFB for 8 seconds until its blue and red indicator light flashes alternately, which means the headset is entering pairing mode.
3. Activate Bluetooth function of the cell-phone to get into search mode and search for Bluetooth devices (please refer to your phone's manual for more instruction).
4. Select "WYZER⁵" among the found devices list, then confirm according to phone instructions.
5. Input pin code "0000" to confirm and finish pairing. When the headset's blue indicator light flashes, it means the headset and mobile phone have completed the pairing and are now connected.

Pairing with Two Phones

Bluetooth headset WYZER⁵ has a dual-link function for connection with two mobile phones simultaneously.

1. Pair the first phone by following the "Pairing with one phone" steps stated above.
2. Turn off the first connected phone's Bluetooth function temporarily.
3. Repeat steps you used to pair the first phone to finish pairing with the second phone.
4. After successful pairing, you can reach the dual-link function in two ways:
 - I. After pairing with the second phone, hold the headset's MFB for 2 seconds and then release. Meanwhile, activate the first paired phone's Bluetooth function and choose "WYZER⁵" in its paired Bluetooth devices list to complete connection.
 - II. After pairing with the second phone, turn off the headset. Then power on the first paired phone's Bluetooth function, and restart the headset. The headset will connect to both paired phones automatically.

NOTE. While the headset is connected with two mobile phones, if the headset is used to make calls with one of them, the headset will temporarily disconnect from the other one automatically, and reconnect after the call ends.

The headset's dual-link function is also dependent on hand-set capabilities and may not be compatible with certain phone brands or models.

VOLUME ADJUSTMENT

WYZER⁵ supports both HSP (Headset Profile) and HFP (Hands-free Profile) profiles. Its call function depends on the type of phones you use.

You can adjust your headset's volume level during calls using your handset.

NOTE. To ensure ergonomics, reduce complexity and size of WYZER⁵, the headset is designed without volume control button.

OPERATION AND INDICATION CHART

Function	Button	Tone Indication	Indicator Light Status
Power ON	Hold the MFB for 5 seconds	2 tones	Both blue and red lights shine 1 second
Power OFF	Hold the MFB for 5 seconds	2 tones	Both blue and red lights shine 1 second, and then go out
Answer a call	Short press the MFB once	1 short tone	Blue light flashes
End a call	Short press the MFB once	1 short tone	Blue light flashes
Reject call	Hold the MFB for 2 seconds	1 short tone	Blue light flashes

Function	Button	Tone Indication	Indicator Light Status
Last call redial	Quick press the MFB twice	1 long tone	Blue light flashes
Voice dialing	Press the MFB once	1 short tone	Blue light flashes
NOTE. Upon hearing the indication tone, please speak clearly the voice dialing signs recorded/stored in the mobile phone.			
Call waiting	Quickly press the MFB twice during calls		Blue light flashes
NOTE. This function must also be supported by your mobile service provider.			

ATTENTION. The above listed functions may be different when used with various mobile phones. Please refer to your mobile phone instruction manual for more information.

INDICATOR LIGHT CHART

With charger plugged in:

Red light flashes twice and then shines steadily	Charging in progress
Red light goes out, blue light shine steadily	Charge complete

Without charger plugged in:

Indicator Light Indication	Headset State
Blue light and red light flash alternately	Pairing
Blue light flashes 3 times quickly	Connected, standby
Red light flashes 3 times quickly	Standby
During connected standby, red light flashes 3 times quickly	Low battery alert

ATTENTION. The headset will be powered off automatically to save power when there is no operation for 5 minutes.

TROUBLE SHOOTING

If you hear noise from the headset during calls:

- Check if the Bluetooth headset and mobile phone are in operating range (10 meters in open space).
- In order to get the best voice quality, we suggest wearing the headset at the same side as the mobile phone.
- Check your headset light indicator. Charge the headset if you see red light indicator.

Nothing can be heard from the headset:

- Check if the headset is on and charged.
- Check whether the headset is paired with the mobile phone successfully.
- Check if the headset is connected with the mobile phone; if not, please connect according to your phone instructions.

Mobile phone failed to connect to the headset:

- Check if the headset is on and has been charged properly.
- Check whether the headset has completed pairing with the mobile phone.
- If the headset fails to connect automatically to the first or the latest used phone, please recharge it, turn it off and then restart, or pair them again.

- Make sure that there is no hindrance, such as a wall or other electronic equipment, between the headset and mobile phone, and that their distance is not over 10 meters.

If the steps above cannot solve the problem, please turn off your mobile phone or its Bluetooth function and then restart.

CAUTION

- Please use your mobile phone and Bluetooth headset WYZER⁵ according to your local laws. Please concentrate on the road when using the headset while driving. Safety comes first.
- Please do not put the headset in places where the ballonet may unfold. The strong unfold power may cause serious injury.
- Please keep the headset away from children (small parts may cause suffocation if put in the mouth or swallowed).
- Please turn off your Bluetooth headset in places that forbid the use of electronic devices.
- The Bluetooth headset is forbidden for use during flight, please turn it off before boarding the airplane.
- To prevent injury to your hearing, do not use the headset at excessively loud levels.

DISCLAIMER. GlobeWyze Inc. will not be liable to any damage, injury or accident due to inappropriate or misuse of the headset, directly or indirectly. It is users' responsibility to abide by pertinent usage laws and regulations.

MAINTENANCE

- Keep the headset dry. Rainwater, humidity and all types of liquids or moisture may corrode its electronic circuits. If the headset does get wet, do not use it until it is completely dry.
- Do not use harsh chemicals, cleaning solvents or strong detergents to clean the device.
- Do not use or store the device in dusty, dirty places. Its moving parts and electronic components may get damaged.
- Do not store the device in very hot places. High temperatures will shorten the talk or standby time of electronic devices, damage batteries, and warp or melt certain plastic components.
- Do not store the headset in very cold areas. When the device returns to its normal temperature, moisture formed inside may damage its electronics.
- Do not drop, knock or shake the device. Rough handling will damage its inside circuit board and delicate structure.
- Do not paint the device - painting may prevent proper operation or operating range.
- When the device is not used for a long time, please fully charge the headset before using it again.

NOTE. The above suggestions are applicable to your headset, battery, charger and spare parts/accessories.

TECHNICAL SPECIFICATIONS

Model No	WYZER ⁵
Bluetooth Standard	Bluetooth V 2.1, CLASS 2
Supported Profiles	HSP (Headset Profile) and HFP (Hands-free Profile)
Radio Frequency Range	2402MHz ~ 2481MHz
Distance	10 meters
Charge Time	1.5 hours
Talk Time	Approx. 3.5 hours
Standby Time	Approx. 85 hours
Size	29 (L) × 17 (W) × 28.5 (H) mm
Weight	7 g

NOTE. The battery life may vary, depending upon your usage pattern or mobile phone settings.