

WOLFVISION[®] *Visualizer*

INSTRUCTIONS VZ-17 / VZ-37



ENGLISH

Precautions

Vorsichtmassnahmen



WARNING!

Risk of electric shock
Dangerous voltage inside

ACHTUNG!

Elektroschockrisiko -
Gefährliche Netzspannung
im Gerätinneren



Please follow these precautions:

USE THIS MACHINE ONLY WITH THE CORRECT VOLTAGE AS SHOWN ON THE TYPE LABEL !

DO NOT EXPOSE THE UNIT TO EXTREME HEAT OR MOISTURE !

DO NOT CARRY THE VISUALIZER HOLDING IT ONLY BY ITS MIRROR ARM (#1) !

DURING TRANSPORTATION PROTECT THE UNIT FROM EXCESSIVE SHOCKS !

Make sure that sufficient air circulation for cooling the unit is possible (ventilation slots on the left and right side of the unit)

If there is any abnormality (abnormal noise, smell, smoke etc.) turn the power off immediately and contact your Visualizer dealer!

Do not use a damaged power cord.
This may cause short circuits or electrical shocks!

Do not modify the Visualizer or operate it without the cover panel firmly in place, to prevent danger!

Do not expose the Visualizer to water, metallic objects or any flammable material. Do not place liquids or wet objects on the working surface! Put them in front of or behind the unit and use it as a camera. If you work with wet hands, cover the remote control with plastic wrap!

Avoid installing the Visualizer in environments where there is radiation.

Avoid installing the Visualizer in locations exposed to strong magnetic fields or electrical currents.
This could cause monitor image distortion or damage to the CCD camera.

If the Visualizer is not used for a long time turn off the main power switch (#34)!

Angeführte Vorsichtsmassregeln unbedingt beachten:

DAS GERÄT NUR MIT DER AUF DEM TYPENSCHILD ANGEgebenEN NETZSPANNUNG VERWENDEN!

DAS GERÄT VOR FEUCHTIGKEIT SCHÜTZEN!

DAS GERÄT NIEMALS AM ABTASTKOPF BZW. ARM AUFHEBEN ODER BEWEGEN!

BEIM TRANSPORT DAS GERÄT VOR ERSCHÜTTERUNG SCHÜTZEN!

Es ist darauf zu achten, dass eine ausreichende Luftzirkulation zur Kühlung des Gerätes möglich ist (Lüftungsschlitze links und rechts unbedingt freihalten!)

Bei jeder Art von Störungsanzeichen (abnormale Geräusche, Geruch, Rauchentwicklung etc.) das Gerät abschalten. Setzen Sie sich bitte in solchen Fällen umgehend mit Ihrem Visualizer-Händler in Verbindung!

Niemals ein beschädigtes Netzkabel verwenden.
Andernfalls kann es zu Kurzschlüssen und zu elektrischen Schlägen kommen!

Am Gerät keinerlei Umbauten vornehmen und das Gerät niemals ohne Gehäusedeckel in Betrieb nehmen!

Keine entflammaren oder metallischen Gegenstände oder Flüssigkeiten in das Geräteinnere dringen lassen! Flüssigkeiten oder nasse Gegenstände nicht auf die Arbeitsplatte, sondern vor oder hinter das Gerät stellen. Bei Arbeiten mit nassen Händen gegebenenfalls das Bedienfeld mit einer Folie abdecken!

Das Gerät nicht im Bereich von starken Magnetfeldern und elektrischen Feldern verwenden.

Das Gerät nicht im Wirkungsbereich von Röntgenstrahlung betreiben. Dadurch können Teile der Kamera beschädigt werden.

Wird das Gerät längere Zeit nicht benutzt, Netzauptschalter (34) abschalten!

Precautions for built-in laser center marker:

Vorsichtsmaßregeln für den eingebauten Laserpositionierpunkt:

CAUTION

LASER RADIATION - DO NOT STARE INTO BEAM

650nm, P<1mW, tp<6ms

CLASS II LASER PRODUCT

AVOID EXPOSURE -
Laser radiation is emitted
from this aperture.

LASER RADIATION
DO NOT STARE INTO BEAM
CLASS 2 LASER PRODUCT
OUTPUT POWER <1mW
WAVELENGTH 650nm
EN 60825-1 March 1997

FDA accession number:
9912688-00

This device complies with
21 CFR 1040.10 and 1040.11

CE

ETL

FCC

This product is built according to Directive EMC and to Directive electrical equipment.

This equipment has been tested and found to comply with the limits for a Class A digital device, pursuant to Part 15 of the FCC Rules. These limits are designed to provide reasonable protection against harmful interference when the equipment is operated in a commercial environment. This equipment generates, uses, and can radiate radio frequency energy and, if not installed and used in accordance with the instruction manual, may cause harmful interference to radio communications. Operation of this equipment in a residential area is likely to cause harmful interference in which case the user will be required to correct the interference at his own expense.

Contents:

Precautions	page 2
Connections	page 5 IMPORTANT
Switchable outputs	page 6
How the Visualizer works	page 6
Basic preparations	page 6
Working on the working surface	page 7
Focusing	page 7
Working outside the working surface	page 7
Synchronized Light field	page 7
Bottom light / Laser center marker	page 8
Working with transparencies	page 8
Macro mode	page 8
Preset function	page 9
Reset function / Power-on preset	page 9
Autoiris / manual iris	page 9
Video recording	page 9
Connecting a computer or video conferencing system	page 9
Text enhancement	page 10 IMPORTANT
Special adjustment of LCD- or DLP projectors	page 10
Infrared remote control	page 11
Automatic lamp changer	page 11
Exchanging lamps	page 11
Thermostat	page 11
Exchanging a fuse	page 12
Mirror cleaning	page 12 IMPORTANT
White balance adjustment	page 12 IMPORTANT
Transportation	page 13 IMPORTANT
Dimensions	page 15
Technical data	page 16
Troubleshooting	page 17+18

Additional chapters for experienced:

On-screen menu / Camera menu	page 13
Reset of on-screen menu settings / menu-presets	page 13
Positive / Negative switching	page 14
Software upgrades	page 14
External synchronization	page 14
Control Connectors (Serial and parallel)	page 14

Detailed settings of the on-screen menu

See on-screen HELP menu of the Visualizers

Contacts:

Manufacturer:

Wolf Vision GmbH
 Vlb. Wirtschaftspark
 A-6840 Götzis / AUSTRIA
 Phone: ++43-5523-52250
 Fax: ++43-5523-52249
 E-Mail: wolfvision@wolfvision.com

Australian distribution:

WolfVision Pty Ltd.
 P.O.Box 59, West Lindfield
 NSW 2070, Australia
 Phone: (02) 9410 3388
 Fax: (02) 9410 3388
 E-mail: wolfvision.australia@wolfvision.com

Asian distribution:

WolfVision Rep office
 27 Woodlands Ind. Park E1
 #01-04 Hiang Kie Ind. Bldg. IV
 Singapore 757718
 Phone: ++65 - 366 9288
 Fax: ++65 - 366 9280
 E-mail:
 wolfasia@mbox2.singnet.com.sg

American distribution:

Wolf Vision Inc.
 655 Sky Way, Suite 119
 San Carlos, CA 94070 / USA
 Phone: (650)802-0786 or 1-800-356WOLF
 Fax: (650)802-0788
 E-Mail: wolfvision.usa@wolfvision.com

Canadian distribution:

WolfVision Canada Inc.
 140 Route 202, Noyan QC JOJ 1B0
 Phone: (450)294-9999
 Tollfree: 1-877-513-2002
 Fax: (450)294-2228
 E-Mail: wolfvision.canada@wolfvision.com

The professional WolfVision Visualizer system was developed and designed by WolfVision in Austria.
 The units are "MADE IN AUSTRIA", Patents (examples): US 5027219, FRG 3833908, CH 678576

Internet Homepage: <http://www.wolfvision.com> / Technical support by E-mail: support@wolfvision.com

ATTENTION: Check which Visualizer model you have!

This is a combined user manual for the professional WolfVision Visualizer models: VZ-17 and VZ-37.

It is noted in the headline if the following chapter applies just to one of these models. Therefore it is important that you check which Visualizer model you have!

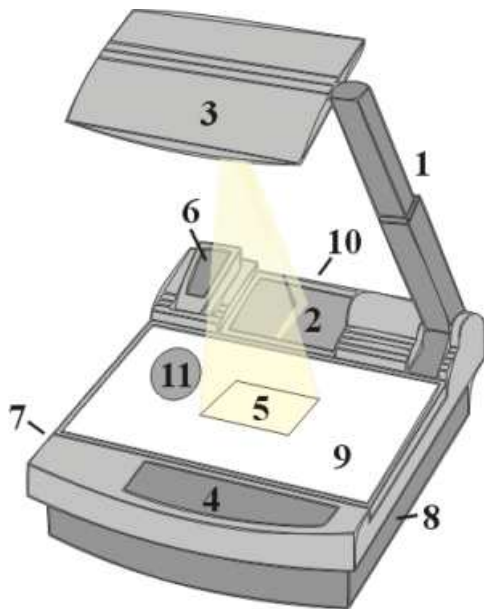

- #1 Arm
- #2 Base mirror
- #3 Top mirror
- #4 Control panel
- #5 Synchronized lightfield (Top light)
- #6 Remote Control
- #7 Ventilation
- #8 Air extraction
- #9 Working surface with built-in Bottom light (removable)
- #10 Connectors (on the back)
- #11 Lamp exchange cover (under the removable bottom light)

CONTROL PANEL

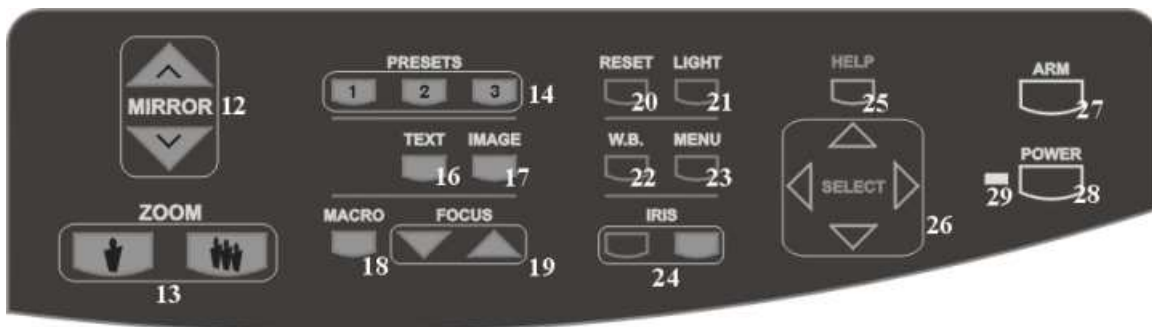

- #12 Upper **MIRROR** up and down (for scrolling) (Can also be moved by hand! This does not cause any harm to the motor of this mirror!)
- #13 **ZOOM** keys (enlargement)
- #14 Three user programmable **PRESETS** (stored by pressing one of the keys for 4 seconds, recalled by pressing quickly)
- #16 **TEXT** Enhancement key (improves the contrast for better readability)
- #17 **IMAGE** (switches the output image on and off)
- #18 **MACRO** (for bigger enlargements - see page 8)
- #19 Manual **FOCUS** adjustment (see page 7)
- #20 **RESET** (activates the Power-on preset)
- #21 **LIGHT** (switches between "Top light", "Bottom light" and "Light off")
- #22 Manual **WHITE BALANCE** adjustment (see page 12)
- #23 **MENU** (activates the on-screen menu - see page 13)
- #24 Manual **IRIS** (brighter and darker picture)
- #25 **HELP** (activates the on-screen help for the on-screen menu - This key is only visible after pressing MENU #23)
- #26 **SELECT** keys for on-screen menu (only visible after pressing MENU #23)
- #27 Motorized **ARM** up and down
- #28 (Standby) **POWER** on and off
- #29 Power **LED** light (red=off, green=on)

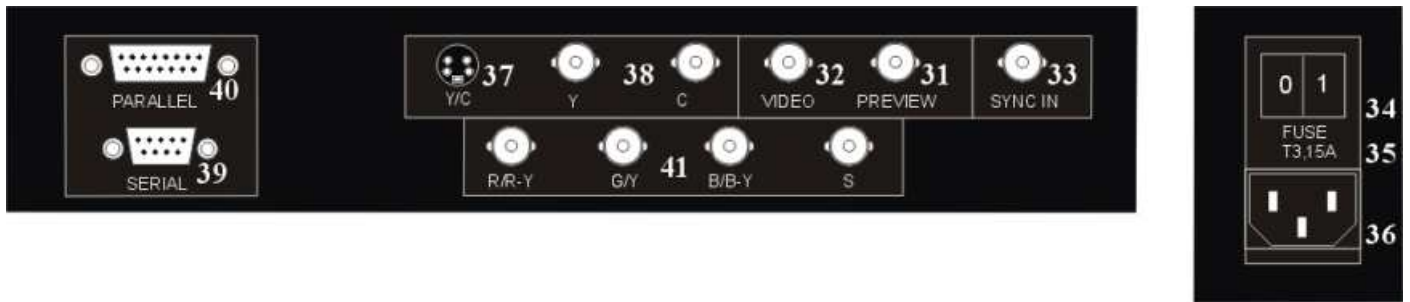

- #31 **PREVIEW** video output (*details see below*)
- #32 Composite **VIDEO** output (*details see below*)
- #33 External **SYNC IN**put (Genlock)
- #34 Main **POWER** switch
- #35 **FUSE** (*see page 12*)
- #36 **POWER** connection
- #37 **Y/C** (S-VHS) output (*details see below*)
4-pin connector
- #38 **Y/C** (S-VHS) output (*details see below*)
2 x BNC connectors
- #39 **SERIAL** port for external remote controlling
- #40 **PARALLEL** port for external remote controlling
- #41 **RGBS** output (*can be switched to YUV on VZ-37 - details see below*)

CHOOSING THE RIGHT VIDEO OUTPUT

IMPORTANT

Y/C output (S-VHS - #37 and #38)

For live image projection it is recommended to use the Y/C output as the signal passes a sharpness enhancer. It even looks better than with the RGBS output of the VZ-37. Only the Component output (YUV) of the VZ-37 offers a better quality than the Y/C-output.

RGBS output (#41)

VZ-37:

The VZ-37 offers a true RGBS-signal. Red, Green and Blue are directly connected to each of the 3 chips of the camera. As a result this output offers the best color reproduction. This signal is also recommended for image processing as it is the original (unprocessed) signal.

(On the VZ-37 this output can be switched to YUV - see below)

VZ-17:

On the VZ-17 the RGBS-signal is actually only a converted Y/C-signal. (As the VZ-17 has a 1-chip camera and no 1-chip camera has a true RGBS output). This output is intended for units which do not have Y/C-input. The quality is better than composite video but not better than Y/C !

Most RGB-monitors or projectors use a separate Sync connection. For units without a separate Sync connection the Sync Signal can be added to the Green-signal.

The "**Sync on green**" function can be switched on and off by simultaneously pressing the following three keys: IMAGE (#17), FOCUS near (#19), FOCUS far (#19). The factory setting is "Sync on green - off".

If "Sync on green" is switched on, make sure that no separate sync cable is connected - the result could be a picture with too much green!

Component output (#41 - VZ-37 only)

The RGBS output of the VZ-37 can be switched to Component output (YUV) by simultaneously pressing the following three keys: IMAGE (#17), IRIS dark (#24), IRIS bright (#24).

The connections are the following: Red=R-Y, Green=Y, Blue=B-Y

Composite video output (#32)

Only use this output if the display device does not have Y/C or RGBS input. This is the oldest standard with the lowest bandwidth the quality is not as good as with the other outputs.

Preview video output (#31)

This is a composite video output for a control monitor. It's the only output that is not switched off, when the IMAGE key (#17) is used. **Do not use this output for the audience's monitor or projector!**

SWITCHABLE OUTPUTS



All outputs of the WolfVision Visualizers - except the Preview output (#31 or #43) - are switchable. Use the IMAGE key (#17) to switch the signal supplied from these outputs on and off. Independently an image is always output by the Preview output (#31 or #43). This output can be used for a control monitor.

A constant sync signal is supplied to all switchable outputs (even in the image off mode) eliminating monitor image distortions when switching.

When the output signal is switched off the IMAGE key on the control panel is illuminated red.

HOW THE VISUALIZER WORKS

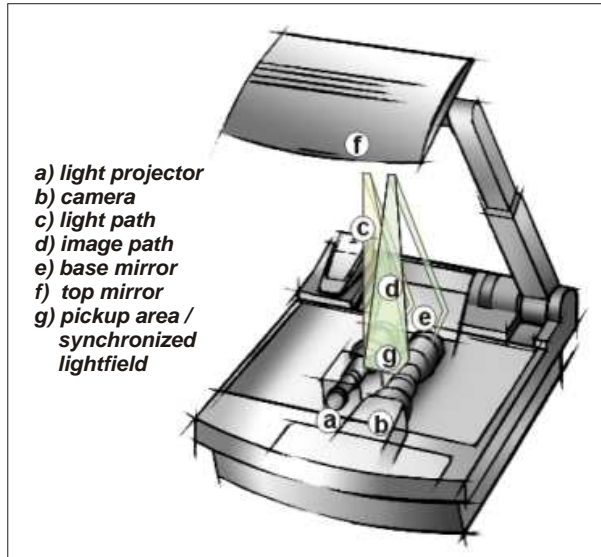

How it works:

A **light projector (a)** inside the unit projects a **lightfield (g)** the same size as the pick-up area of the built-in camera via the **base mirror (e)** and the **top mirror (f)** onto the working surface. The image is recorded by the **camera (b)** using the same path.

The lenses of the **light projector (a)** and the **camera (b)** are synchronized. Thus the size of the light field on the working surface changes when the user changes the zoom range of the camera.

This scanning and illumination system is a worldwide patent from WolfVision.

BASIC PREPARATIONS

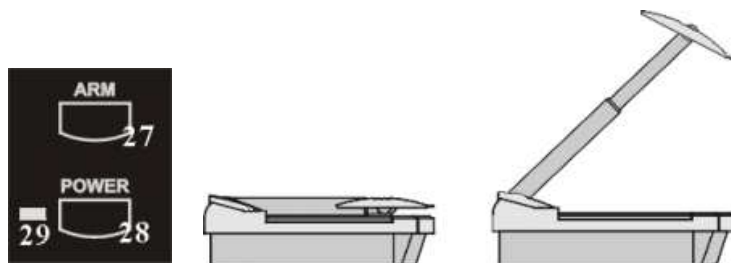

1. Connect the power cable to the unit (#36) and plug it in.
2. Connect a control monitor (if required) to the Preview output (#31 or #43).
3. Connect a large viewing monitor or a projector to one of the outputs of the Visualizer.
For choosing the right output please read the previous pages!
4. Turn the main power switch (#34, on the back of the unit) to "I". The red power indicator (#29) on the control panel indicates that power is supplied.
5. If the arm is folded down press the ARM key (#27) on the control panel, then the arm comes up **automatically**.
6. Press the POWER key (#28) on the control panel. The Visualizer now runs the "power-on preset" (=automatic focusing of an A5 format on the working surface) during which the green LED light (#30) is flashing. As soon as the green LED light stays illuminated you can start working with the Visualizer.

(The behaviour of the unit once that power is supplied to the unit or after the POWER key is pressed can be changed in the unit's menu - see page 13 and on-screen help menu)

WORKING ON THE WORKING SURFACE

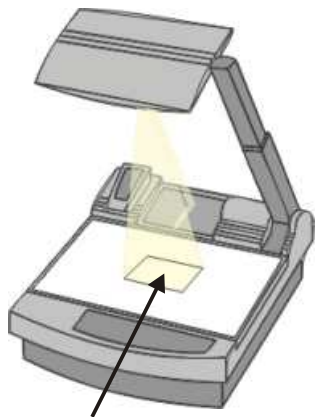

Synchronized lightfield

1. Place your subject material on the working surface. A **synchronized lightfield** on the working surface marks the pick-up area of the built-in camera! Just place your subject material in the illuminated area.
2. Select the enlargement required with the ZOOM keys (#13).
3. Use the MIRROR keys (#12) on the control panel or the remote control to change the vertical position of the pick-up area. The upper mirror can also be moved by hand! This does not cause any harm to the motor of this mirror!

DO NOT TOUCH THE MIRROR SURFACE, AS FINGERPRINTS CAUSE BRIGHT AND HAZY SPOTS ON THE PICTURE! ALWAYS KEEP THE MIRROR CLEAN! CAUTION: SENSITIVE FRONT COATED MIRROR!

4. Adjust the sharpness with the FOCUS keys (#19)

FOCUSING



When the Visualizer is turned on the focus automatically adjusts to the working surface level. As a result it is not necessary to readjust the focus if you are only working with flat material (text, photos etc.).

Furthermore, due to the great depth of focus of the Visualizer it is rarely necessary to readjust the focus. **Only very high objects require a focus adjustment.**

If you have misadjusted the focus and want to set it back for working with flat objects just press both focus keys (#19) on the control panel of the unit (not on the remote control!) simultaneously. This activates the **Auto focus for flat objects**. (With this function the Visualizer checks the mirror position and optimizes the focus for the working surface level.)

WORKING OUTSIDE THE WORKING SURFACE

For showing 3-dimensional objects with the WolfVision Visualizer, just place them on the working surface and adjust ZOOM and FOCUS (as mentioned). Due to a special WolfVision lens the object can be up to 25 cm (9.7") in height. If the object is too big for the working surface or if you want to show it from the side just place it behind or in front of the unit and tilt the top mirror by hand or using the MIRROR keys (#12).

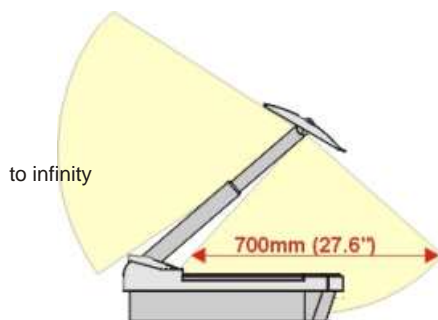

In this way it is also possible to make recordings of subjects in the room or surrounding area, as with a video camera by just tilting the reflector head.

Due to the great focal range it is possible to show details in every distance to the unit.

If you want to record people you should turn off the light with the LIGHT key (#21), so that they are not blinded by the light.

SYNCHRONIZED LIGHTFIELD



If the top light of the Visualizer is used (normal working condition) a synchronized lightfield always marks the pick-up area of the built-in camera on the working surface. The alignment of this lightfield is made for working on the working surface.

Because of the oblique mounting of the camera and the light projector of the Visualizer the lightfield shifts to the left when the distance between the Visualizer and the scanned object is increased (when capturing images outside of the working surface). This means that the lightfield no longer exactly shows the recorded area. In this case switch off the Visualizer's top light with the LIGHT key (#21) and work with room light.

BOTTOM LIGHT / LASER CENTER MARKER

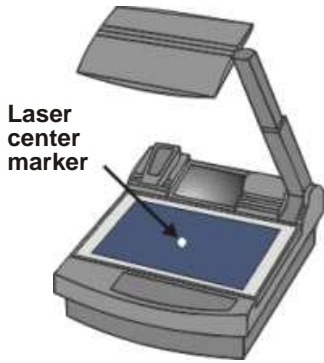

The LIGHT key (#21) can be used to switch between:

- "Top light" (with Synchronized Lightfield)
- "Bottom light" (with Laser Center Marker) and
- "Light off"

The bottom light should be used for dark transparent materials such as **x-rays** or for very small transparent materials such as **slides**.

Using the bottom light has the disadvantage that the Synchronized Lightfield of the top light no longer marks the pick-up area of the built-in camera. However as a substitute the Visualizers have a built-in Laser Center Marker, which marks the center of the pick-up area. This can also be used for quick positioning of objects (especially with big enlargements, like when picking up a slide)

This Laser Center Marker is only visible on the working surface and **NOT on the picture the audience sees**. For safety reasons the Laser Center Marker is automatically switched off when the top mirror is tilted to record outside of the working surface. If required the Laser Center Marker can also be switched off completely in the unit's menu (see page 13 and on-screen help menu).

Please note that for technical (optical) reasons the laser center marker can not show the exact middle center of the pickup area in every position of the arm. This is not a failure of the unit! However it is always very close to the center.

WORKING WITH TRANSPARENCIES



The working surface of the Visualizer (#9) has a special crystalline white color, which is especially designed for perfect reproduction of transparencies.

Even though the professional Visualizers have a built-in bottom light it is **recommended to use the top light for transparencies**, because of the better color reproduction and the advantage that the Synchronized Lightfield still shows the pickup-area of the built-in camera.

However in these situations it is recommended to use the bottom light:

- If the transparency is very dark
- If the transparency is very wavy and causes reflections
- If the room light causes reflections on a transparency

MACRO MODE

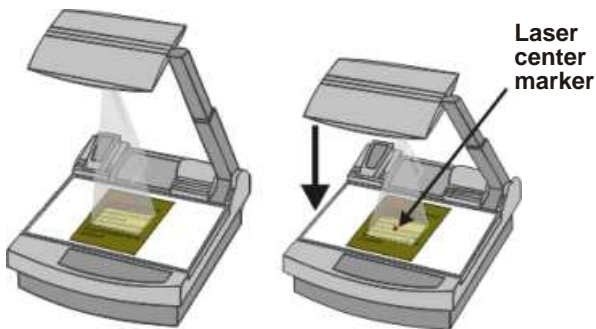

In the fully extended position of the arm, the smallest pick-up area is **42 x 33mm (1.6" x 1.3")**. When pressing the MACRO key (#18) the length of the arm is automatically reduced, this allows for greater enlargements. In the macro mode the smallest pick-up area is: **30 x 22mm (1.2" x 0.9")**.

There is no loss of resolution in the macro mode, as this is an optical and **not** a digital zoom extension.

When the macro mode is activated the MACRO key on the control panel is illuminated red.

Please note that the macro mode has the following limitations:

- The **depth of focus** is not as large as in the fully extended position of the arm.
- The **largest** pick-up size is only about 42 x 33 mm (1.6" x 1.3").
- When zooming the **Synchronized Lightfield** stays at a larger size and no longer marks the pick-up area of the built-in camera. As a substitute the **Laser Center Marker** (see above chapter) is activated.

If sufficient depth of focus in the macro mode is more important than big enlargements, it is possible to switch the Visualizer from 12x zoom to 11x zoom in the Visualizer's menu (see page 14). The smallest pick-up size in the 11x macro mode is only 33 x 25mm (1.3" x 1"), but the depth of focus is larger than in the 12x macro mode.

PRESET FUNCTION



WolfVision Visualizers offer the possibility of programming three presets for the functions: Zoom, Focus, Iris, Light, Image, Text, Macro and Mirror position*. They can be recalled by pressing one of the three PRESET keys (#14) on the control panel or the remote control.

This function is very useful for example if a user requires one preset for papers on the working surface, one for working with slides (bottom light) and one for an object placed in front of the unit. During his presentation the user just has to press one of the PRESET keys when he changes from one object to the other.

For programming a preset just adjust every function as required and then keep one of the PRESET keys pressed for more than 4 seconds. The on-screen menu tells you when the preset is stored.

Less than 4 seconds: Recalling a preset
More than 4 seconds: Saving a new preset

* You can select in the unit's on-screen menu if the mirror position should be stored in a preset or not (see page 13). Default is: YES.

RESET FUNCTION / POWER-ON PRESET



When switching on the unit the "Power-on Preset" is activated (=Top light on, Zoom at 210 x 148mm, Focus on the working surface level, Mirror center). This function can be switched off in the units menu (#23) if required - see help menu (#25).

This "Power-on Preset" can also be recalled during operation of the unit by pressing the RESET key (#20)

AUTOIRIS / MANUAL IRIS



WolfVision Visualizers are equipped with autoiris. That means that the brightness of the camera image adjusts automatically. Using the IRIS keys (#24) the autoiris function is switched off. In this mode the Iris can be adjusted manually.

When using the ZOOM keys (#13) the autoiris function is switched on again. Before the iris closes completely, the Visualizer automatically dims the light.

The standard auto iris level can be set brighter or darker in the unit's menu (#23) - see help menu (#25).

VIDEO RECORDING

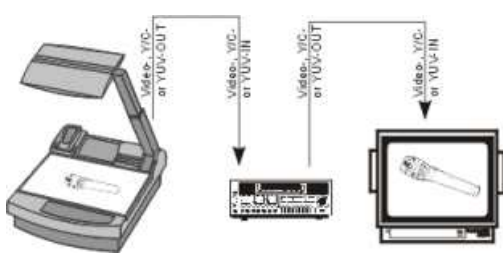

For video recording simply connect the Composite video output (#32) or the Y/C output (#37) of the Visualizer to the according input of your video recorder.

Please note that the Y/C output offers the better picture quality than the Composite video output. Connect a control monitor to the output of the video recorder. The RGBS output (#40) of the VZ-37 can be switched to YUV for professional videorecorders with component input by simultaneously pressing the following keys: IMAGE (#17), IRIS dark (#19) and IRIS bright (#19).

CONNECTING A COMPUTER OR VIDEO CONFERENCING SYSTEM

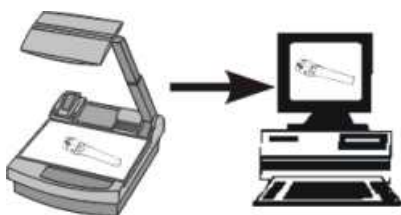

A Visualizer can be used as document- and object-camera for video conferencing systems. Furthermore it can be used as a 3-D scanner for computers in order to digitize Visualizer images for image processing etc. The computer has to be equipped with a frame grabber card or another video INPUT device.

In order to archive the best picture quality please read the chapter "Choosing the right video output" (page 5).

TEXT ENHANCEMENT



For improving the readability of text, sketches and x-rays press the TEXT-key (#16). This mode enhances the contrast of the picture. Please note that in this mode the colors are darker than usual. To switch off the text enhancement mode press the TEXT key again. While the text mode is activated the TEXT key on the control panel is illuminated red.

SPECIAL ADJUSTMENT OF LCD/DLP-PROJECTORS



Please note that LCD- or DLP-projectors require some special adjustments for perfect projection of a Visualizer image:

DETAIL / SHARPNESS Enhancers

Nearly all LCD- or DLP-projectors have a built-in sharpness enhancer for video signals. The level of this sharpness enhancement is adjustable with a setting called DETAIL (on most projectors). Please note that for the readability of small characters a LOW detail setting for Visualizer images is better!

CONTRAST / BRIGHTNESS

With the standard setting of many LCD- or DLP-projectors the picture is too bright if black text on a white background is being projected. There are 3 possible ways of correcting this problem:

- Option 1: Close the Visualizer's iris slightly with the IRIS dark key (#19). This is the quickest solution but it is only temporarily, because once you press a zoom key the unit switches back to autoiris and the picture will be as bright as before.
- Option 2: Reduce the standard auto iris level in the units menu (#23) - see help menu (#25) for details. This will keep the iris level permanently lower than usual. However this has the disadvantage that the output picture may be too dark for other units connected to the Visualizer (e.g. monitor, video recorder, computer)
- Option 3: Reduce the brightness of your LCD- or DLP-projector. Better projectors can store individual brightness settings for each input. So an ideal setting for the Visualizer input can be made, while keeping the setting for the other inputs (e.g. computer, video recorder).

To make the ideal LCD-/DLP-projector adjustment for Visualizer projection, we recommend to put a white sheet of paper with text and some objects with different colors on the working surface. Keep an eye on the readability of the text and the accuracy of the colors.

In order to check how the actual output signal of a Visualizer looks, we recommend to connect a CTR monitor (not an LCD monitor!) to the Visualizer and use the monitor picture as reference image.

WINDOW Function (only for certain projectors)

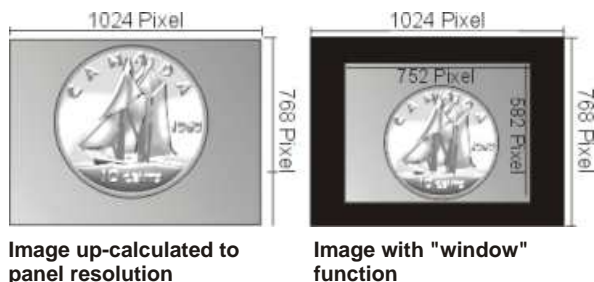

The Visualizers output a picture of approx 752x582 pixels (depending on model). Most modern LCD-/DLP-projectors have a NATIVE RESOLUTION of 1024x768 pixels. In order to display the Visualizer image on the full screen size the projectors up-calculate the image to their panels pixel size. Most projectors do this conversion perfectly, however with some projectors some picture quality is lost in this process. That is why some projectors have a "Window"-function. With this function only as many pixels of the display as required for the video picture are used and the image is not "blown up" to the full panel size.

INFRARED REMOTE CONTROL

Please note that an infrared remote control can only be used up to a certain distance to the unit. Objects situated between the Visualizer and the infrared remote control and a weak battery may interfere with the reception.

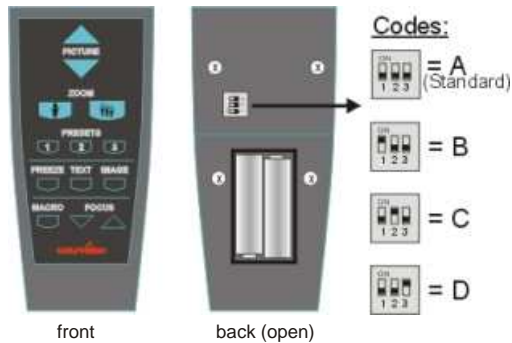

If the Visualizer can only be controlled from a close distance or if it cannot be controlled at all with the infrared remote control you may have to change the batteries.

Open the cover on the back of the remote control by hand and replace the two 1.5 V AA batteries with new ones.

If a user works with a number of WolfVision Visualizers simultaneously each unit can be set to a different infrared code, so up to 4 units can be controlled individually with their remote controls.

In order to change the infrared codes, first open the 4 screws on the back of the remote control and set the DIP-switches to the required code A, B, C or D (see graphic above). Then press the MENU key (#23) on the control panel of the Visualizer for one second until the on-screen menu appears. Then go into the "Misc. Settings" menu and set the "IR Code" to A, B, C or D.

AUTOMATIC LAMP CHANGER



WolfVision Visualizers are fitted with an automatic lamp changer. If one lamp fails, there is no need to replace it immediately, as the automatic lamp changer automatically switches to the second lamp. When the unit changes lamps there is an on-screen message saying: "Changing lamp".

When switching on the unit the Visualizer checks if both lamps are working. If one lamp fails there will be an on screen message for a couple of seconds displaying "Change lamp". This prevents a user from forgetting to change a defective lamp.

If a lamp is not fully defective but worn out and as a result the light output is quite weak, you can switch manually to the second lamp by pressing the LIGHT key (#21) for 1 second.

EXCHANGING LAMPS

1. Turn the unit off (#28) and disconnect the power cord!
2. Remove the bottom light (#9) by pulling the two black bolts (situated left and right of the control panel) to the front and lift up the bottom light plate.
3. Remove the lamp exchange cover (#11) by turning it to the right and lifting.
4. Change the lamp (or both lamps)

Before changing the lamp allow it to cool or use a cloth to avoid burning a finger! When pressing a new lamp into the socket use a cloth to prevent fingerprints on the lamp!

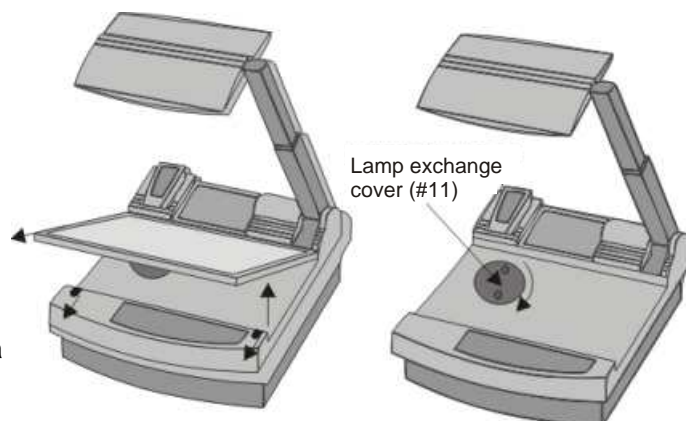

Only use 12 V/100 W halogen lamps (socket: GY 6,35), types: Philips 7023, Osram HLX 64625, Ansi FCR, LIF A1/215 etc. These are relatively inexpensive standard OHP lamps.

THERMOSTAT

If the unit gets too hot (improper ventilation or air extraction) a built in thermostat will switch off the light of the Visualizer. Verify that proper ventilation and air extraction is available and allow the unit to cool.

EXCHANGING A FUSE

Before changing a fuse disconnect the power cable. The fuse (#35) is situated behind a small lid between the power socket and the main power switch. It can easily be opened with a small screwdriver etc.

Please make sure that the fuse is put in the right way round (An arrow on the socket indicates the right direction of the fuse).

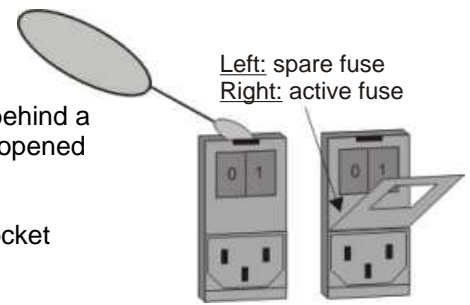

The type of fuse is: T 3.15A. Do not use any other type !

Change the fuse for a new one and switch the unit on again. If the fuse fails again contact your Visualizer dealer! With most Visualizers the fuse never fails during the whole lifetime of the unit.

CLEANING

IMPORTANT

Mirror: Please note that dust on the base mirror (#2) inside the unit has little effect on the picture quality (as it is out of the focal range). However the top mirror (#3) always has to be kept clean! Wipe the mirror gently with the WolfVision Visualizer cleaning cloth.

Please note: Switch off the power before cleaning a mirror in order to make sure that the Laser Center Marker is off. (The Laser Center Marker is automatically switched off anyway, when the mirror is turned to the outside)

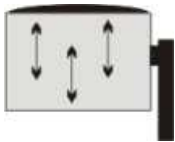

CAUTION: Sensitive front coated mirror!
Move the tissue in vertical direction only ! (Horizontal scratches would cause ugly reflections) Avoid high pressure !

DO NOT USE ORDINARY GLASS CLEANER OR ALCOHOL
- THE RESULT WOULD BE A SLIGHTLY BLUE MIRROR SURFACE !

The glass covering the mirror inside the unit should also be kept clean.

Cabinet: Clean the cabinet by gently wiping it with a soft cloth. Never use strong cleaning agents such as benzine or alcohol!

WHITE BALANCE ADJUSTMENT

IMPORTANT

Each time the lighting condition changes, the user should adjust the white balance of the Visualizer's camera, in order to optimize the color reproduction. The Visualizer's top- and bottom light have the same color temperature so normally a new white balance adjustment is not necessary when changing from one light to the other, but if there is also **room light** or **sun light** shining on the working surface, the white balance should be adjusted.

Top light: First, zoom in on a white object (for example a white paper) until there is only white on the screen. Then press the W.B. key (#22).

Bottom light: Turn on the bottom light with the LIGHT key (#21). Remove everything from the working surface. Zoom to the smallest picture. Then press the W.B. key (#22).

You can adjust the white balance either for the top or for the bottom light and it works well with both lights.

When the white balance adjustment is finished successfully the message "WHITE OK" appears on the monitor after a few seconds. The new white balance is stored automatically and is preserved even if the power supply is interrupted.



TRANSPORTATION

IMPORTANT

Please make sure that you pack up the Visualizer in the supplied box as explained in this graphic. This is very important to avoid damage to mirror, arm and other sensitive parts of the unit!

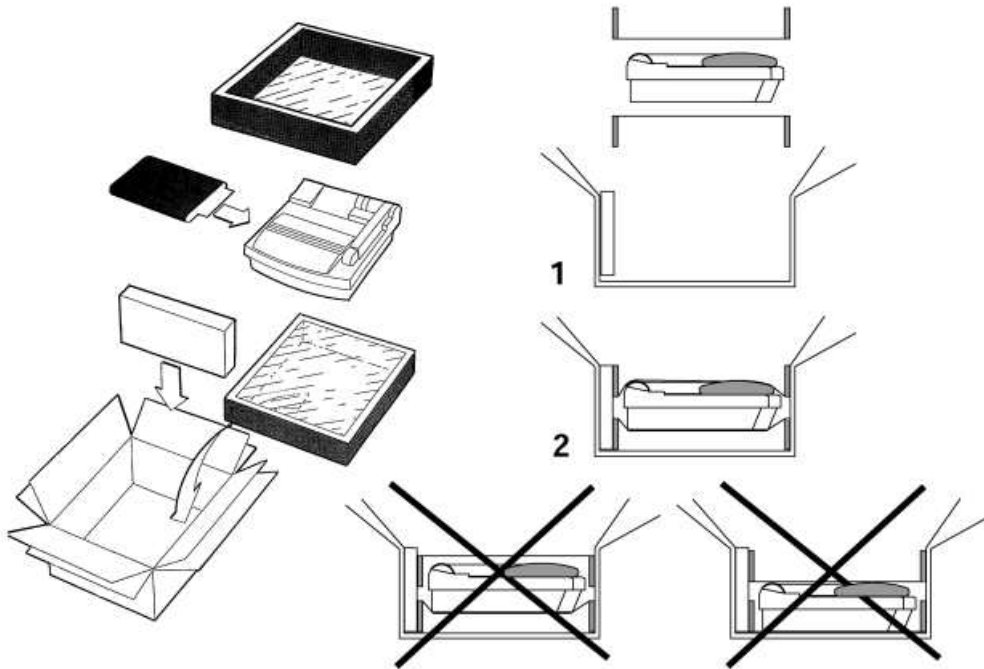

The following chapters are for experienced users only:

ON-SCREEN MENU / CAMERA MENU



For standard use of the WolfVision Visualizer it is NOT necessary to go into the Visualizer's menu and change settings. Inexperienced users should not try to make any adjustments there. That is why the keys for the camera menu (#25 and #26) are dark on the control panel and not easy accessible.

These keys and the on-screen menu only become visible after pressing the MENU key (#23) **for 1 second!** This is to prevent that the menu key is pushed by accident by an inexperienced user.



When the menu appears on the screen, settings of the Visualizer's basic functions can be made using the 4 select keys (#26). On the Visualizers VZ-37 is also possible to change a great number of settings of the built-in camera.

If you require more information on a function in the on-screen menu just set the cursor in the respective line and press the HELP key (#25). A detailed description of this function appears on the screen.

The functions of the on-screen menu are not described in this user manual as the help menu is an integrated part of the Visualizer's software and checking this information on your Visualizer assures that you get the right information for your unit.

RESET OF ON-SCREEN MENU SETTINGS / PRESETS

The settings in the on-screen menu can be set back to the factory defaults. "Reset" is one item in the on-screen menu. In case you can not read the menu on a screen you can also set the unit back to the factory defaults by simultaneously pressing the keys: RESET (#20) + MENU (#23).

Please note that this reset-function does not reset the sync settings of the RGBS outputs or the RGBS / YUV setting of the VZ-37! (To reset those settings use the key combinations listed on the back of this manual)

The on-screen menu also offers the possibility to store three different menu settings as Menu-presets.

POSITIVE/NEGATIVE SWITCHING (VZ-37)

The output image of the Visualizers can be switched from positive to negative in the on-screen menu.

TIP: If you require negative images often, you can store a Preset with these settings (see page 9). This saves you from entering the on-screen menu for switching.

SOFTWARE UPGRADE

The software of your Visualizer (including the on-screen help menu) can easily be upgraded to the latest version. It can be done by connecting a computer or a modem to the RS232 port of your Visualizer. Please consult your WolfVision dealer or check our website (<http://www.wolfvision.com/wolf/techinfo.html>).

EXTERNAL SYNCHRONIZATION

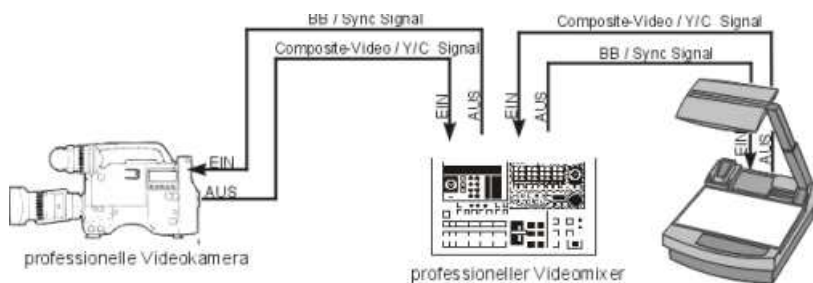

If Visualizer images are mixed and processed (fade-in, fade-out, mix/wipe) with images from one or more video cameras (or Visualizers) using a special effect unit without TBC (time base corrector), all units connected must be genlocked.

Genlocking is achieved by supplying the same composite video signal (VBS) or black burst (BB) signal to the Extern Sync input (=Genlock input) of each unit connected.

In order to genlock the WolfVision Visualizer with another video signal, simply connect this signal to the Sync input (#33) of the Visualizer where a composite video or a black burst signal can be connected.

With a VZ-37 fine adjustment of color-phase (SC) and H-phase can be made in the unit's on-screen menu.

With a VZ-17 it is necessary to open the unit and adjust the settings with a screwdriver on the camera itself. Please leave this to a technically experienced person, as there is sensitive and potentially dangerous electronics inside the unit!

Start with H-phase adjustment, followed by rough adjustment of "0/180" followed by fine adjustment with SC.

Genlock operation with a playback signal of a video recorder is only possible if the signal is time base corrected via a TBC device.

CONTROL CONNECTORS

Serial port

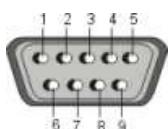

9-pin D-Sub connector on unit, male, front side

Pins: 2:RX, 3:TX, 5:GND

Serial protocol

A detailed description of the serial protocol (including status report and position setting) is available on request from your WolfVision dealer or can be downloaded from our website: <http://www.wolfvision.com/wolf/techinfo.html>.

Parallel port (15-pin D-Sub, 12-24 V)

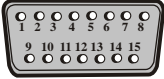

15-pin D-Sub connector, 12-24V on unit, male, front side

First Function, Shift key is not activated

1. Relay-Out (closed if the arm is complete down) **
2. Lock Arm (if activated, no arm function is possible)
3. Power ON
4. Power Off
5. Arm Up
6. Arm Down
7. Parallel GND *
8. DC +12 V
9. Light On/Off
10. Zoom Tele
11. Zoom Wide
12. Mirror Up
13. Mirror Down
14. Shift inactive
15. GND

Second Function, Shift key is activated

1. Relay-Out (closed if the arm is complete down) **
2. Focus near
3. Focus far
4. Iris open
5. Iris close
6. Image On/Off
7. Parallel GND *
8. DC +12 V
9. Preset1
10. Preset 2
11. Preset 3
12. Text Enhancement
13. Macro On/Off
14. Shift active
15. GND

* Parallel GND is the ground for the opto-isolated control inputs. DC GND is the ground for DC + 12 V and also for Video out. If you want to use DC + 12 V for the control inputs make a connection between DC GND and Parallel GND.

** If the relay is open: Resistor value at least 3k3.

DIMENSIONS

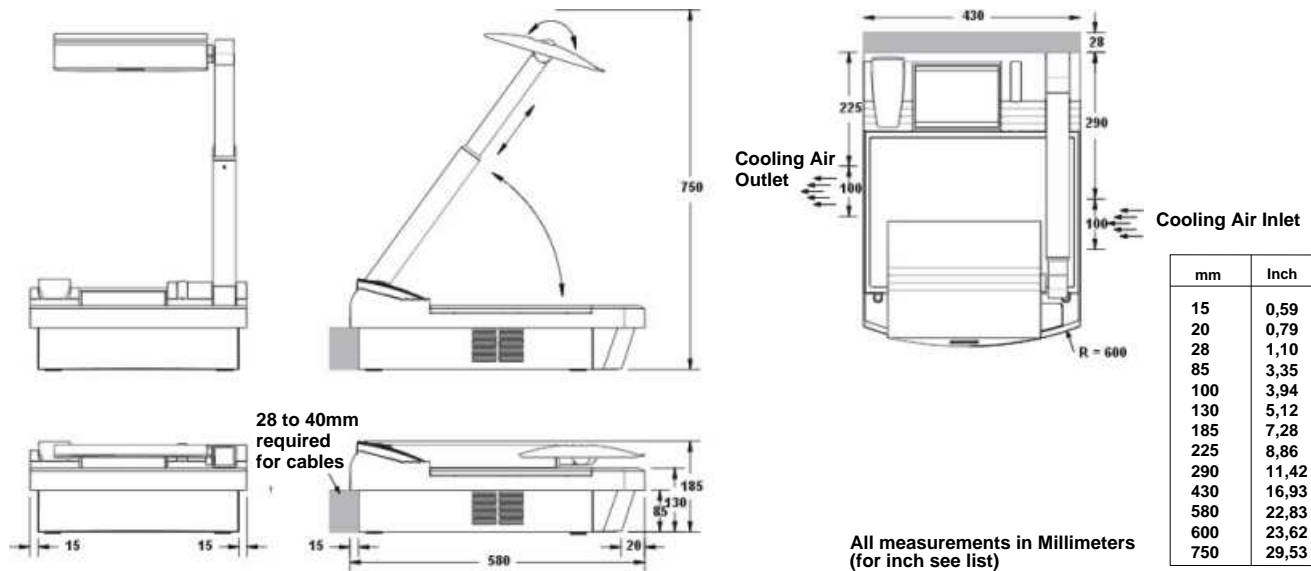

TECHNICAL DATA:

	VZ-37	VZ-17
Camera	1/3" 3-CCD Video	1/2" 1-CCD Video
Output signals	PAL or NTSC	
Pictures per second (as picked up by the camera)	PAL: 50 half-pictures / NTSC: 60 half-pictures	
Horizontal resolution	800 lines	470 lines
Vertical resolution	420 lines (PAL) / 370 lines (NTSC)	420 lines (PAL) / 350 lines (NTSC)
Effective Pixel (=pixels which are actually used for the image information)	3 x 752 x 582 (PAL) / 3 x 768 x 494 (NTSC)	752 x 582 (PAL) / 768 x 494 (NTSC)
Color reproduction	100% lifelike colors	very good colors
Vertical image-frequency	PAL: 50 Hz / NTSC: 60 Hz	
Horizontal image-frequency	15.7 kHz	
Signal format	interlaced	
Iris	automatic and manual	
White balance adjustment	automatic and manual	manual
Synchronized lightfield	yes (in size of the pick-up area of the built-in camera - for easy positioning of objects)	
Laser center marker	yes	
Text enhancement function	yes (in color)	
On screen menu	yes, for operation functions, camera settings and on-screen help	yes, for operation functions
Menu reset function	yes	-
Lens / Zoom	two telezoom lenses (12 x optical zoom, incl. Macro), f = 2.0	
Max. pick-up area	360 x 270 mm (14.4" x 10.8") on working surface, outside of working surface unlimited	
Min. pick-up area on working surface	30 x 22 mm (1.2" x 0.9")	
Max object height on working surface	250mm (9.7")	
Depth of focus	70mm (2.75") on small object (42 x 33 mm) / 250mm (9.7") on large object (360 x 270 mm)	
Shadow free illumination	yes	
Illumination of hollow objects	yes	
Disturbing stray light	none at all	
Blinding of audience or speaker	none at all	
Infrared remote control	yes	
Light source	standard halogen lamp (12V/100W), 3200 Kelvin (constant light spectrum)	
Automatic lamp changer	yes (with built-in spare lamp)	
Reflection free area	whole working surface	
Motorized top mirror	yes - for scrolling text with remote control	
Motorized arm	yes - for up/down position and macro zoom function	
User programmable presets	3 (plus 8 fixed presets through RS232)	
Special working surface for transparencies	yes	
Bottom light	yes, built-in, size: 380 x 280 (15" x 11") = whole working surface, light source: 4 x CCFL	
Image on/off switch	yes (with constant sync signal)	
Positive/Negative switch (in menu)	yes*	-
Outputs	RGB(S) (<i>true RGB, BNC plugs</i>), Component Video (<i>YUV - BNC plugs</i>), S-Video (<i>4-pin and BNC plugs</i>), 2x Composite Video (<i>BNC plugs</i>)	RGB(S) (<i>converted Y/C, BNC plugs</i>), S-Video (<i>4-pin and BNC plugs</i>), 2x Composite Video (<i>BNC plugs</i>)
Inputs	Genlock (<i>Sync in</i>), Serial control input (<i>RS232</i>)	
Weight	17 kg (36 lbs)	
Made in	Austria (European Community)	

* Units produced after October 2000

Specifications and availability subject to change!

TROUBLESHOOTING

Symptoms:	Check points:
No power	<ul style="list-style-type: none"> - Is a power cord connected? - Is the main power switch (# 34, on the back of the unit) switched to "I"? - Check fuse! (#35)! (see page 12)
Bright and hazy spots in the picture	<ul style="list-style-type: none"> - Is the top mirror (#3) or the glass over the base mirror (#2) dirty? If yes clean it BUT BE CAREFUL - (see page 13)
Low light	<ul style="list-style-type: none"> - Is the lamp worn out? - Are you using the Visualizer with the correct voltage? - Is the lamp correctly placed in the socket?
No light	<ul style="list-style-type: none"> - Is the light switched off (LIGHT keys #21)? - Is the lamp burned out? - Is the light slot covered?
The left edge of the picture is black / the right edge of an object isn't illuminated (using the Visualizer as a video camera)	<ul style="list-style-type: none"> - Switch off the light with the LIGHT off key (#21) and work with room light. (This is not a failure of the unit, see page 7 - "Synchronized Lightfield")
No monitor picture	<ul style="list-style-type: none"> - If the IMAGE key (#17) is illuminated red on the control panel, then the switchable outputs are switched off? - Switch on with the IMAGE key - Is the IRIS closed? Press the IRIS bright key (#24) - Check cable connection and input of monitor/projector! - When using an RGBS output check if the correct Sync-Mode is selected (see page 5)
Reflections / Glare	<ul style="list-style-type: none"> - The working surface of the Visualizer is reflection free (provided that the material is not very wavy). If there are reflections in the picture it must be due to room light. Switch off the room light!
Poor picture quality on the projection screen (using the Visualizer together with a projector)	<ul style="list-style-type: none"> - This is mostly due to bad adjustment of the projector. Connect a monitor to the Visualizer. If the picture quality is good on the monitor check the adjustment of the projector.
Picture is too bright (when using an LCD video projector)	<ul style="list-style-type: none"> - An LCD projector should be adjusted for Visualizer projection see page 10 for details.
Autoiris does not work	<ul style="list-style-type: none"> - The autoiris function is switched off when using the IRIS keys (#24). It is switched on again when using the ZOOM keys (#13)
Bad picture quality	<ul style="list-style-type: none"> - Check the set-ups and quality of your monitor or projector. - On VZ-37 check the camera set-ups in the on-screen menu. If you are unsure about the settings use the "reset" function in the menu or use the key combination: RESET (#20) + MENU (#23).
False colors	<ul style="list-style-type: none"> - Adjust the white balance (see page 12) - NTSC: adjust color phase of monitor or projector
Too much green in the picture (when using the RGBS output)	<ul style="list-style-type: none"> - Use either SYNC ON GREEN or SEPARATE SYNC but not both at the same time! (see page 5).
No color (B/W only)	<ul style="list-style-type: none"> - Check the TV standard of the monitor or projector (PAL/Secam/NTSC) - Check color adjustment of the monitor or projector - Check the Y/C cable (if there is color when using the composite video output, the Y/C cable may be defective)
<u>VZ-37</u> : Wrong colors or bad picture quality (using the RGBS / YUV output of VZ-37)	<ul style="list-style-type: none"> - Check if the Visualizer and the monitor or video projector are both switched to either RGBS or YUV. The VZ-37 can be switched to the other standard by simultaneously pressing: IMAGE, IRIS open and IRIS close.
No stable picture (Sync problems)	<ul style="list-style-type: none"> - RGBS-output: Check Sync connection. Use either SYNC ON GREEN or SEPARATE SYNC (see page 5). - Adjust V-Hold on monitor or H/V-frequencies on projector or monitor
Infrared remote control does not work	<ul style="list-style-type: none"> - Change the battery! - If the unit cannot be controlled with the infrared remote control even from a close distance and with a new battery it may be due to a wrong frequency (see page 11).

Symptoms:	Check points:
<p>The lightfield on the working surface is much larger than the recorded area.</p>	<p>Please note that the lightfield has to be a little bit larger than the recorded area, otherwise it would not fit in all positions (on the working surface). However if it is much too big check the following:</p> <ul style="list-style-type: none"> - First check if it is possible to adjust your monitor. Many monitors do not display the whole picture. Some show more of the right side, some more of the left side etc. Check if there is an UNDERSCAN function - with this function you can display 100% of the Visualizer picture. - If you are working with a projector (CTR) check the "blanking" of the projector - If you are sure that the lightfield is still much larger than the recorded area and it is not due to a wrong adjustment of your monitor or your projector, consult your WolfVision dealer. The size of the lightfield can be adjusted electronically using a special WolfVision service software.
<p>The Laser Center Marker is slightly right or slightly left of the middle of the pick-up area.</p>	<p>- This is <u>not</u> a failure of the unit. It is optically impossible that the Laser Center Marker is 100% in the horizontal middle of the picture with every length of the arm (macro mode on or off). But it is adjusted to be very close to the middle with every length of the arm.</p>
<p>The size of the lightfield does not change when zooming in and out</p>	<p>You are in the MACRO mode - press the MACRO key (#18) - <i>see page 8</i></p>
<p>It is not possible to record the whole working surface. The zoom stops at a largest picture of approx. 42 x 33mm (1.6" x 1.3").</p>	<p>You are in the MACRO mode - press the MACRO key (#18) - <i>see page 8</i></p>
<p>Depth of focus is not as large as usual</p>	<p>You are in the MACRO mode - press the MACRO key (#18) - <i>see page 8</i></p>
<p>Depth of focus in the macro mode is too low for my application.</p>	<p>You can change the macro mode from 12x macro to 11x macro in the unit's menu. The enlargements are not as big as before but the depth of focus is higher in the 11x macro mode - <i>see page 14 and on-screen help menu.</i></p>
<p>Projection picture is frozen</p>	<p>Check if the projector has frozen the picture (search for a FREEZE key on the projector or its remote control)</p>

WOLFVISION® Visualizer

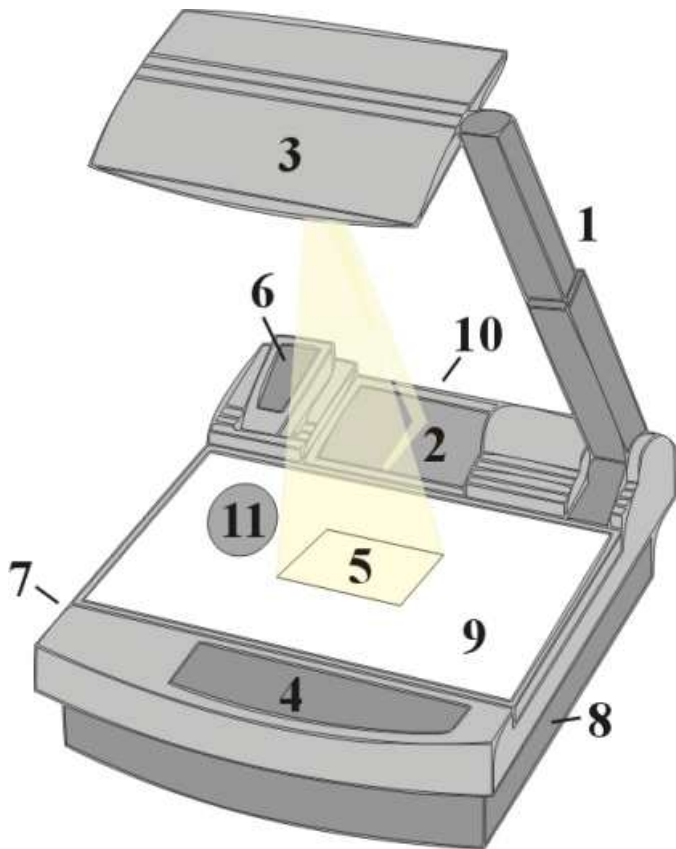

CODES:

Storing presets:

Press a Preset key for 4 seconds

Activating the camera menu:

Press MENU key for 1 second

Auto focus for flat objects:



Sync on green switching:



VZ-37: RGBS / YUV switching

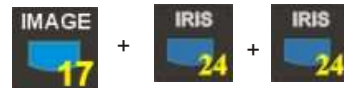

Manual change to second lamp:

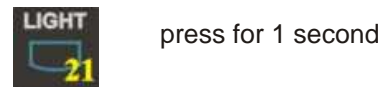

Demo mode:

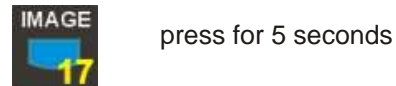

Resetting the Visualizer's menu:



Text enhancement (in color)

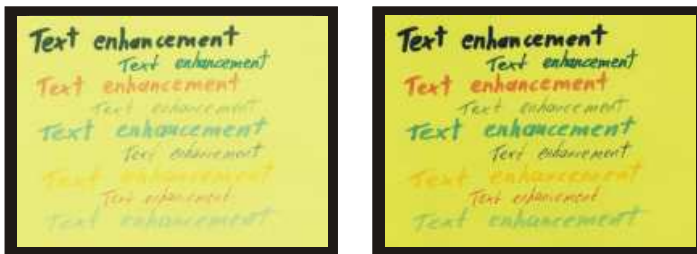

TEXT 16 By pressing the "TEXT" button, the contrast of the picture is improved dramatically, resulting in much better readability of text, sketches and x-rays.

Control panel on the Visualizer:

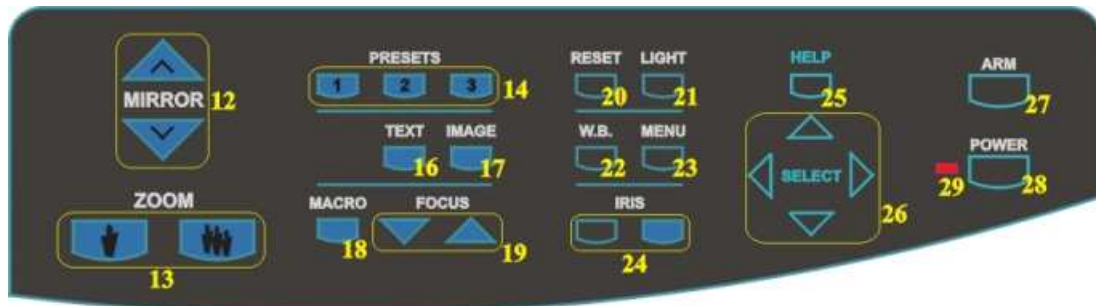

Remote control:

