

DP159RGZ Evaluation Module

This document describes how to use and configure the DP159RGZEVM along with recommendations for system hardware implementation. These recommendations are only guidelines and it is the designer's responsibility to consider all system characteristics and requirements. Engineers should refer to the datasheet for technical details such as device operation, terminal description, and so forth.

Contents

1	Overview	2
	1.1 What is the DP159?	2
	1.2 What is the DP159RGZEVM?.....	2
	1.3 What is Included in the DP159RGZEVM?.....	2
	1.4 DP159RGZEVM Board	3
2	Hardware Description	3
	2.1 Video Connectors for DP159 Ports.....	4
	2.2 Enable/Reset	4
	2.3 Power.....	4
	2.4 Jumper Configuration	5
	2.5 Component Population Configuration	6
	2.6 Local I ² C Access Through J5	7
	2.7 Local I ² C Access Through USB Interface via TUSB3410	7
	2.8 Rsdj Potentiometer.....	9
3	Quick Start Guide.....	9
4	References	9
5	EVM Bill of Materials.....	10
6	EVM Schematics	12
7	EVM Layout	19

List of Figures

1	DP159RGZEVM Board	3
2	DP159RGZEVM Block Diagram	3
3	Register Status / Control Tab	8
4	Eye Scan Tab	9
5	HDMI Input Connectors	12
6	DP159RGZ.....	13
7	HDMI TX Connector	14
8	DP159RGZEVM Select Options.....	15
9	Reset	16
10	1.1- and 3.3-V Regulators	17
11	TUSB3410.....	18
12	Layer 1 (Top)	19
13	Layer 2 (GND)	19
14	Layer 3 (Power)	20
15	Layer 4 (Power)	20
16	Layer 5 (GND)	21

I²C is a trademark of NXP.

All other trademarks are the property of their respective owners.

17	Layer 6 (Bottom).....	21
----	-----------------------	----

List of Tables

1	Jumper Settings.....	5
2	Aardvark I ² C (J5) Pin-Out.....	7
3	DP159 Target I ² C Address	7
4	DP159RGZEVM Bill of Materials	10

1 Overview

1.1 What is the DP159?

The DP159 is a Dual-Mode DisplayPort to Transition Minimized Differential Signal (TMDS) retimer supporting Digital Video Interface (DVI) 1.0 and High Definition Multimedia Interface (HDMI) 1.4b and 2.0 output signals. The DP159 supports the Dual-Mode Standard version 1.1 type 1 and type 2 through the DDC link. The DP159 supports data rates up to 6 Gbps per data lane to support UltraHD (4K x 2K / 60 Hz) 8 bits per color high resolution video and HDTV with 16-bit color depth at 1080p (1920 x 1080 / 60 Hz). The DP159 can automatically configure itself as a redriver at data rates < 1.0 Gbps or as a retimer above this data rate.

1.2 What is the DP159RGZEVM?

The DP159RGZEVM is a PCB created to help customers evaluate the DP159 device for video applications. This EVM can also be used as a hardware reference design for implementation of the DP159 in the RSB package. PCB design/layout files can be provided upon request to provide PCB design illustrations of the routing/placement rules.

Please note that the EVM design supports both the standard DP159 application and a DP159-thru-HDMI application, so it contains many components that would not be needed by a typical DP159 application. A separate reference design specific to the DP159 is available for customers.

1.3 What is Included in the DP159RGZEVM?

The major components of the EVM are as follows:

- DP159RGZ
- Standard DP sink connector (connects to source)
- Standard HDMI source connector (connects to sink)
- DC power regulators
- I²C™ programming interface for external I²C host connection
- USB interface (I²C utility available)

1.4 DP159RGZEVM Board

Figure 1 illustrates the DP159RGZEVM board.

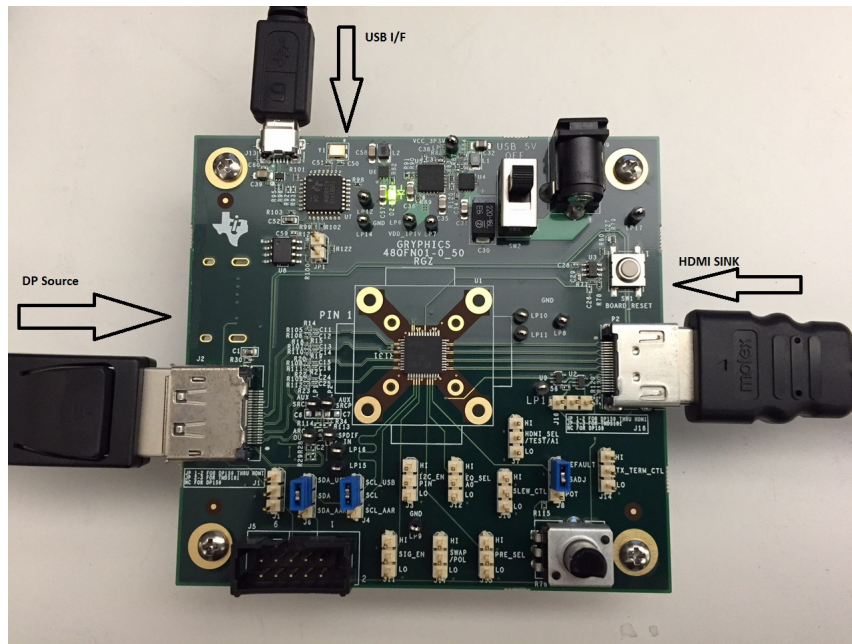
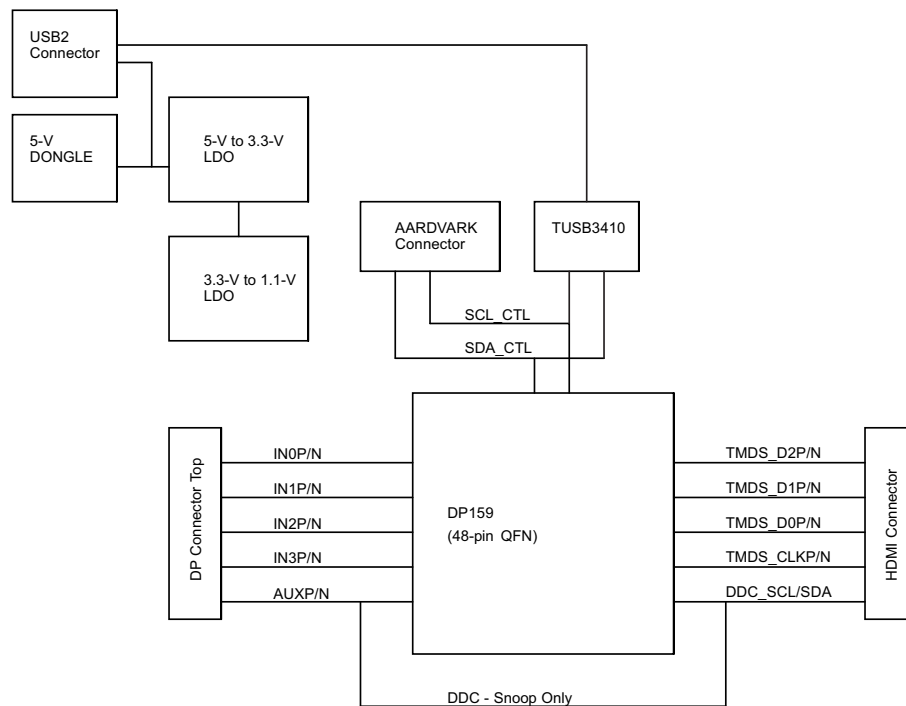

Figure 1. DP159RGZEVM Board

2 Hardware Description

Figure 2 shows the DP159RGZEVM block diagram.



100-Ω differential impedance for HDMI differential pairs.

Figure 2. DP159RGZEVM Block Diagram

2.1 Video Connectors for DP159 Ports

The EVM has a DP connection for the source and a HDMI connection for the sink. J2 is a standard DP connector (Molex 47272-0001). P2 is a standard HDMI connector (Molex 4715-10001). There is a third video connection on the board for a HDMI source (P1), this function is not installed on the DP159RGZEVm.

2.2 Enable/Reset

There are three device enable/reset options to use with the EVM:

(A) Supervisor circuitry option

This is the default configuration on the DP159RGZEVm. The enable (EN) signal is held low until the power good (PG) from the 3.3-V voltage regulator reaches a stable high-voltage level then released high.

(B) RC timing option

C26 external capacitor and internal resistor are used to control the EN ramp time after the device is powered on. C26 is a Do Not Install (DNI option) by default. C26 needs to be installed and R77 needs to be uninstalled to enable this option.

(C) External control option

A push button (SW1) is provided for manual control of the DP159's EN/OE input.

2.3 Power

A DC power jack (J9) to accept a 5-V wall power adapter is provided on the EVM. The DC power jack (CUI Inc. PJ-202AH) has an inner diameter of 2.1 mm and an outer diameter of 5.5 mm. The tip of the +5-V power supply must be positive. A +5-V power supply of at least 1.5 A that meets the given requirements can be used to power the DP159RGZEVm. Power is provided to the EVM from the 5-V wall power adapter when SW2 is set to position 1.

CAUTION

Care should be taken to not plug in any power source higher than the configured voltage (5 V).

Alternately, it is possible to power the EVM by connecting a USB Micro cable from J13 to a USB host and setting SW2 to position 3.

2.4 Jumper Configuration

Jumpers are provided to operate the device/EVM in different configurations. [Table 1](#) lists the jumper settings.

Table 1. Jumper Settings

Jumper	Signal Name	Description	Default Config
J1	HPD_SRC	JP 1-2 for DP159 thru HDMI JP 2-3 for NOT USED NC for DP159	NC
J3	I2C_EN_PIN	JP 1-2 for I ² C ENABLE JP 2-3 for PIN STRAP NC – PIN STRAP (internal pulldown)	NC: Enables device configuration from I ² C or pin straps.
J4	SCL	JP 1-2 for USB IF TO I ² C JP 2-3 for EXT IF TO I ² C NC – N/A	JP 1-2: USB I ² C Interface
J6	SDA	JP 1-2 for USB IF TO I ² C JP 2-3 for EXT IF TO I ² C NC – N/A	JP 1-2: USB I ² C Interface
J7	HDMI_SEL_TEST_A1	JP 1-2 for: <ul style="list-style-type: none"> • I²C Addr bit A1 = 1, when I2C_EN = H • DVI mode, when I2C_EN = L JP 2-3 for: <ul style="list-style-type: none"> • I²C Addr bit A1 = 0, when I2C_EN = H • Normal mode, when I2C_EN = L NC for weak internal pulldown (HDMI mode)	NC
J8	VSADJ	JP 1-2 for 7.0 kΩ JP 2-3 for adjustable resistance NC – N/A	JP 1-2: Default of 7.0 kΩ
J10	SLEW_CTL	JP 1-2 for fastest data rate JP 2-3 for 20 ps slow NC for 40 ps slow	NC
J11	SIG_EN	JP 1-2 for Signal Detect Enabled	NC
		JP 2-3 for Signal Detect Disabled	
		NC for weak internal pullup (Detect Disabled)	
J12	EQ_SEL_A0	JP 1-2 for: <ul style="list-style-type: none"> • I²C Addr bit A0 = 1, when I2C_EN = H • Fixed EQ at 14 dB, when I2C_EN = L JP 2-3 for: <ul style="list-style-type: none"> • I²C Addr bit A0 = 0, when I2C_EN = H • Fixed EQ at 7.5 dB, when I2C_EN = L NC for adaptive EQ	NC
J14	TX_TERM_CTL	JP 1-2 for No TX termination	NC
		JP 2-3 for TX termination 75–100 Ω	
		NC for auto termination set	
J15	PRE_SEL	JP 1-2 for –5 dB JP 2-3 for –2.5 dB NC for 0 dB	NC

Table 1. Jumper Settings (continued)

Jumper	Signal Name	Description	Default Config
J16	CEC_EN	JP 1-2 for DP159 thru HDMI	NC
		JP 2-3 for NOT USED	
		NC for DP159	
J17	SWAP/POL	JP 1-2 for Polarity Swap	NC
		JP 2-3 for Lane Swap	
		NC for No Swap	

2.5 Component Population Configuration

To allow the DP159RGZEVMM to support both the default DP input as well as a HDMI test input, there are many components that need to be removed, placed, or modified depending on the board configuration. Here's a summary of the default component configuration for the DP159RGZEVMM. In addition, the unused HDMI receptacle is depopulated.

Function	Reference Designator	DP159RGZEVMM
Differential Pair - IN	C11, C12, C13, C14, C15, C16, C24, C25	populated with 0.1 μ F
Differential Pair - HDMI IN	R14, R15, R18, R19, R20, R21, R22, R23	not populated
SDA / SCL - HDMI	R16, R17, R24, R25, R123, R124	not populated
Differential Pair - DP IN	R112, R109, R111, R108, R110, R107, R106, R105	populated with 0 Ω
SDA / SCL / HPD - DP	R33, R31, R32 (R126, R135, R132, R133 - snoop)	populated with 0 Ω
Pullup Differential Pair HDMI IN	R1, R2, R3, R4, R6, R7, R8, R9	populated, but not connected

2.5.1 HPD Snoop Option

To accommodate systems that do not properly resend DDC commands after HPD goes low, we have implemented a HPD snoop mode on the DP159RGZEVMM. This mode allows the HPD line to be routed around the DP159, but remain connected to the DP159 on the sink side to allow the DP159 to snoop its state. This snoop mode is disabled by default on the DP159RGZEVMMs.

- Pop R131, no pop R129, R130, R139 for HPD on
- No pop R131, pop R129, R130, R139 for HPD snoop only

2.5.2 DDC Snoop Option – not Available for DP159RGZ REV B

To accommodate systems that do not properly support clock stretching on the DDC lines, we have implemented a snoop mode on the DP159RGZEVMM. This mode allows the DDC lines to be routed around the DP159RGZ, but remain connected to the DP159RGZ on the sink side to allow the DP159RGZ to snoop the DDC traffic. This snoop mode is enabled by default on the DP159RGZ REV B1 EVMs.

- Pop R126, R125, R132, R133. No pop R31, R32 – DP159RGZ, DDC snoop only
- Pop R31, R32. No pop R126, R125, R132, R133 – DP159RGZ, DDC on

2.6 Local I²C Access Through J5

Access to DP159's local I²C signals is provided via the J5 input connector. Note that I²C signal levels should be at 3.3 V when I²C interface is accessed through the connector.

A standalone external I²C host can be connected via J5 for debug and control purposes. An example of an external I²C Host controller is the Total Phase Aardvark I²C/SPI Host Adapter (Total Phase Part#: [TP240141](#)). Sample scripts for this I²C Host controller are provided by request.

Table 2. Aardvark I²C (J5) Pin-Out

J5 pin #	Description	J5 pin #	Description
1	SCL_CTL	2	GND
3	SDA_CTL	4	NC
5	NC	6	NC
7	NC	8	NC
9	NC	10	GND

Table 3. DP159 Target I²C Address⁽¹⁾

DP159 I ² C Target Address							
Bit 7 (MSB)	Bit 6	Bit 5	Bit 4	Bit 3	Bit 2	Bit 1	Bit 0 (W/R)
A6	A5	A4	A3	A2	A1	A0	
1	0	1	1	1	1	0	0/1

⁽¹⁾ The target I²C address for DP159 can be modified by the EVM jumper settings.

2.7 Local I²C Access Through USB Interface via TUSB3410

Access to DP159's local I²C signals is also provided through the TUSB3410 on the DP159RGZEVm using a USB TI Utility called Eye Scan. To use the utility:

- Install the Eye Scan software from Texas Instruments
- J6 must be set to SDA – SDA_USB
- J4 must be set to SCL – SCL_USB
- Attach USB micro cable to J13 and to the host computer

NOTE: The USB connection should be made prior to installing any DP or HDMI cables.

- Start the Eye Scan software

Figure 3 shows the Register Status / Control tab.

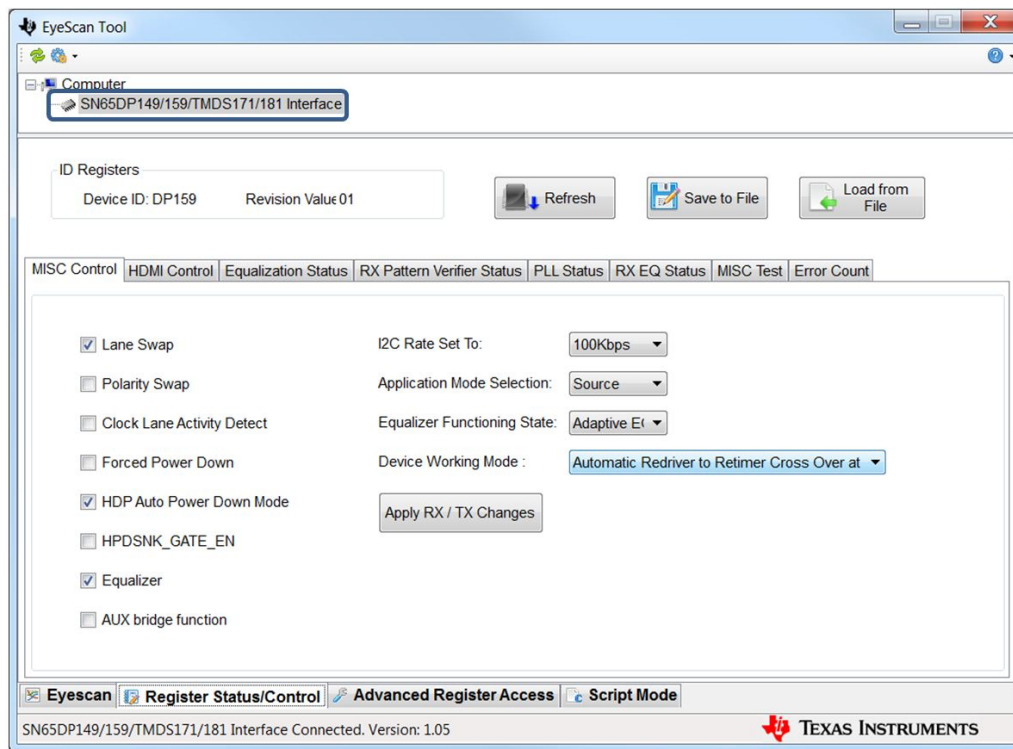

Figure 3. Register Status / Control Tab

Confirm that the SN65DP149/159/TMDS171/181 Interface is present and selected at the top. If it is not, check the USB connection and confirm that the driver is loaded in Device Manager. It may take a moment for the USB driver to load, if the DP159RGZ does not appear, hit the Refresh button. This tab can be used to read and write the status and control registers of the device.

Figure 4 shows the Eye Scan tab.

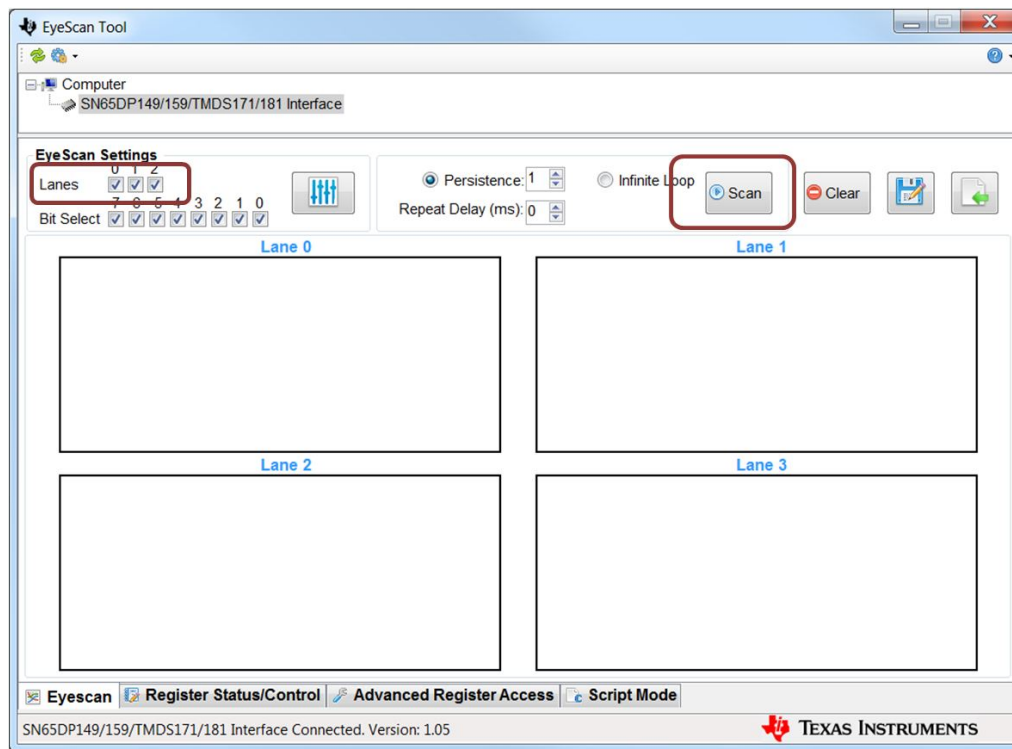

Figure 4. Eye Scan Tab

To run an Eye Scan, select the Eye Scan tab, select the relevant lanes, and press scan. Please note that Eye Scan cannot be performed when the device is in retimer mode, it does not function in redriver mode.

2.8 Rsadj Potentiometer

The default Rsadj value on the DP159RGZEM is 7.0 k Ω . The optimal value for an application may vary from 4.7 k Ω to 7 k Ω . To allow customers to test the effects of various Rsadj values, there is a potentiometer on the EVM at R76. The Rsadj value can be varied by turning the knob and setting J8 to [2,3].

3 Quick Start Guide

The following steps provide quick start instructions:

1. Connect USB cable from J13 to a USB host, set SW2 to 3. LED D2 should light up.
Option: Apply 5-V power to J9, set SW2 to 1. LED D2 should light up.
2. If using external I²C adapter instead of pin straps, please configure the DP159 at this step using J5 or through the USB interface.
3. Plug in a DP source using a standard DP cable into J2 (Standard DP connector).
4. Plug in an HDMI video sink device into P2 (standard HDMI connector) using a standard HDMI cable.
5. Video output on HDMI sink should be observed.

4 References

1. DP159 Data Sheet
2. [Aardvark Adapter User Manual](#)
3. High-Definition Multimedia Interface Specification Version 1.4b.
4. High-Definition Multimedia Interface Specification Version 2.0.

5 EVM Bill of Materials

Table 4 lists the DP159RGZEVMBOM.

Table 4. DP159RGZEVMBill of Materials

Item	Qty	Reference	Part	PCB Footprint	Manufacturer	Part Number
1	2	C1,C52	1 uF	603	Taiyo Yuden	LMK107B7105KA-T
2	12	C9,C10,C17,C18,C19,C21,C23,C29,C40,C46,C59,C60	0.1uF	402	Yageo	CC0402KRX5R6BB104
3	5	C8,C20,C35,C36,C57	10uF	805	TDK	C2012X5R1A106K125AB
68	1	C31	10uF	805	TDK	C2012X5R1C106K085AC
4	8	C11,C12,C13,C14,C15,C16,C24,C25	0.1uF	201	TDK	C0603X5R0J104M
5	5	C22,C37,C41,C42,C47	0.01uF	402		
6	1	C26 - DNI	DNI_200nF	402		
7	1	C27	18pF	402	AVX	04025A180JAT2A
8	1	C28	220pF	402		
9	1	C30	220uF	7343	Kemet	T491D227K016AT
10	1	C34	3.3 nF	402		
11	1	C32	22uF	805		
12	2	C39,C58	2.2uF	805		
13	35	C2,C3,C4,C5,C6,C7,C38,R14,R15,R16,R17,R18,R19,R20,R21,R22,R23,R24,R25,R35,R87,R92,R93,R104,R113,R114,R120,R123,R124,R125,R126,R129,R130,R132, R133	DNI	402 / 201		
14	2	C45,C49	22pF	402		
15	2	C50,C51	33pF	402		
16	1	D1	Zener 6V	SOT23	Diodes Inc.	MMBZ5233B-FDICT-ND
17	1	D2	LED Green 0805	805	Lite On	LTST-C171GKT
18	1	JP1	JUMPER	HDR_THVT_1x2_100		
19	13	J1,J3,J4,J6,J7,J8,J10,J11,J12,J14,J15,J16,J17	HDR3X1 M .1	HDR_THVT_1x3_100	3M	961103-6404-AR
20	1	J2	Display_Port_Connector_Sink_0	DISPLAYPORT	Molex	47272-0001
21	1	J5	Header 5x2 0.1" thru-hole	con_thvt_shrd_2x5_100_m	3M	N2510-6002-RB
22	1	J9	2.1mm x 5.5mm	PJ-202AH	CUI Inc.	PJ-202AH (PJ-002AH)
23	1	J13	USB Micro B	USB Micro B	FCI	10103592-0001LF
24	17	LP1,LP2,LP3,LP4,LP5,LP6,LP7,LP8,LP9,LP10,LP11,LP12,LP13,LP14,LP15,LP16,LP17	LP	TESTLOOP	KOBIKONN	151-103-RC
25	1	L1	2.2 uH	1008	TDK	VLS252010ET-2R2M
26	1	L2	1 uH	1008	TDK	NLCV25T-1R0M-EFR
27	4	L3, L4, L5, L6	CHOKE	805	Murata	DLW21SN900HQ2L
28	1	P1 - DNI	HDMI_IN	CON_HDMI_RT_19_0p50mm	Molex	471510001
29	1	P2	HDMI_OUT	CON_HDMI_RT_19_0p50mm	Molex	471510001
30	2	Q1,Q2	FDV301N_NFET_8V	SOT23	Fairchild Semiconductor	FD301N
31	8	R1,R2,R3,R4,R6,R7,R8,R9	50	201		
32	1	R5	100	402		
33	6	R10,R11,R99,R100,R101,R121	1K	402		
34	3	R12,R27,R81	100K	402		
35	1	R13	10	402		
36	12	R31,R32,R33,R34,R105,R106,R107,R108,R109,R110,R111,R112	0	201		

Table 4. DP159RGZ EVM Bill of Materials (continued)

Item	Qty	Reference	Part	PCB Footprint	Manufacturer	Part Number
37	6	R28,R29,R58,R59,R45,R46	2K	402		
38	7	R77,R80,R83,R84,R89,R122, R131	0	402		
39	1	R30	1M	402		
40	1	R127	500K	402		
41	1	R36	75	402		
42	1	R56	27K	402		
43	16	R57,R60,R61,R62,R63,R64, R65,R66,R67,R68,R69,R70, R71,R72,R73,R74	65K	402		
44	1	R75	7.06K (6.98K OK)	402		
45	1	R76	PTV09 10K POT	THRUHOLE	BOURNS	PTV09A-4015F-B103
46	3	R78,R98,R102	10K	402		
47	2	R79,R88	4.7K	402		
48	1	R82	500	402		
49	1	R85	750K	402		
50	1	R86	240K	402		
51	1	R90	1.87K	402		
52	1	R91	4.99K	402		
53	1	R94	1.5K	402		
54	2	R95,R96	33	201		
55	1	R103	15K	402		
56	1	R115	47K	402		
57	1	SW1	PB_SWITCH	SW_MOM_2NO	OMRON	B3SN-3012P
58	1	SW2	3POS_SPDT	THRUHOLE_3POS	NKK Switches	MS13ANW03
59	1	U1	DP159RGZ	48_RGZ	TI	
60	1	U9	SN74AUP1G04	DCK	TI	SN74AUP1G04DCKR
61	1	U2	SN74CBT1G125	DCK	TI	SN74CBT1G125DCKR
62	1	U3	TPS3808G30DBVT	6DBV	TI	TPS3808G30DBVT
63	1	U4	TPS62150A	RGT16	TI	TPS62150ARGTT
64	1	U6	TPS61240	6DRV	TI	TPS61240DRVT
65	1	U5	TPS74201RGWT	RGW20	TI	TPS74201RGWT
66	1	U7	TUSB3410	LQFP32	TI	TUSB3410VF
67	1	U8	24LC256	8SOIC	ON Semiconductor	CAT24C256W
69	1	Y1	12 MHz Crystal	ECX-32	ECS Inc.	ECS-120-20-33-TR
70	1	U16	TPD2E001	drl_5pin	TI	TPD2E001

6 EVM Schematics

Figure 5 through Figure 11 show the DP159RGZEVMS schematics.

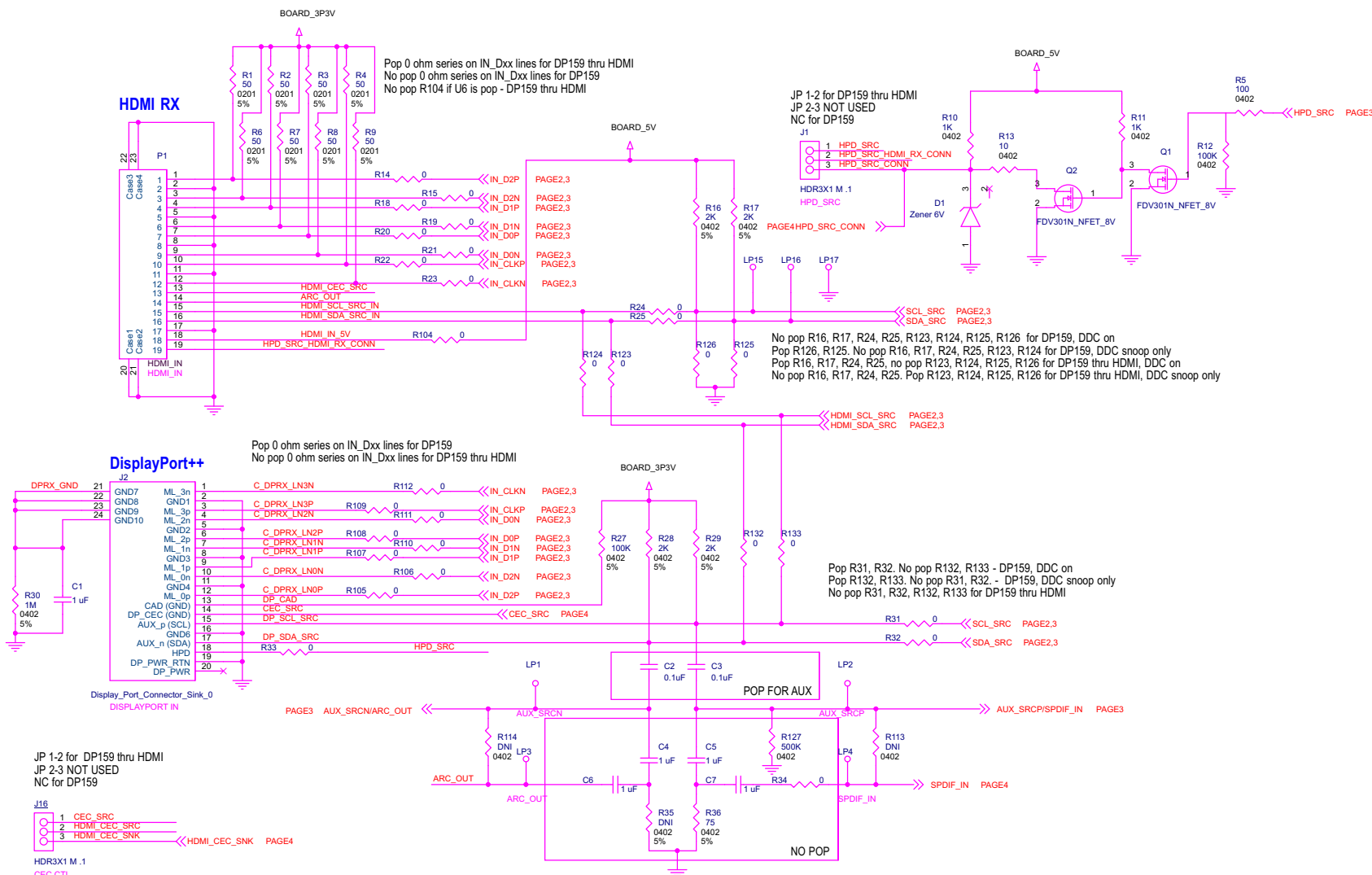

Figure 5. HDMI Input Connectors

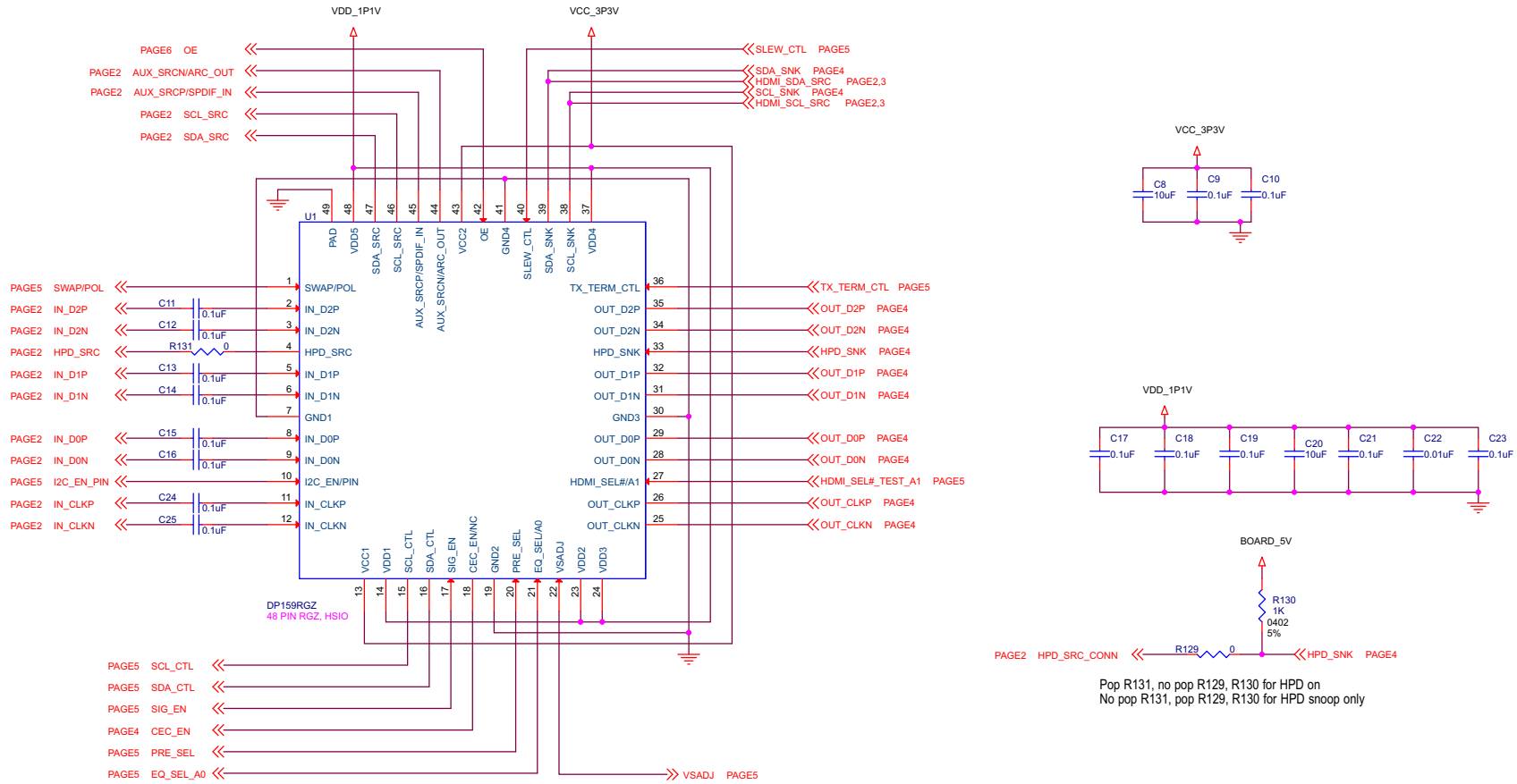

Figure 6. DP159RGZ

HDMI TX

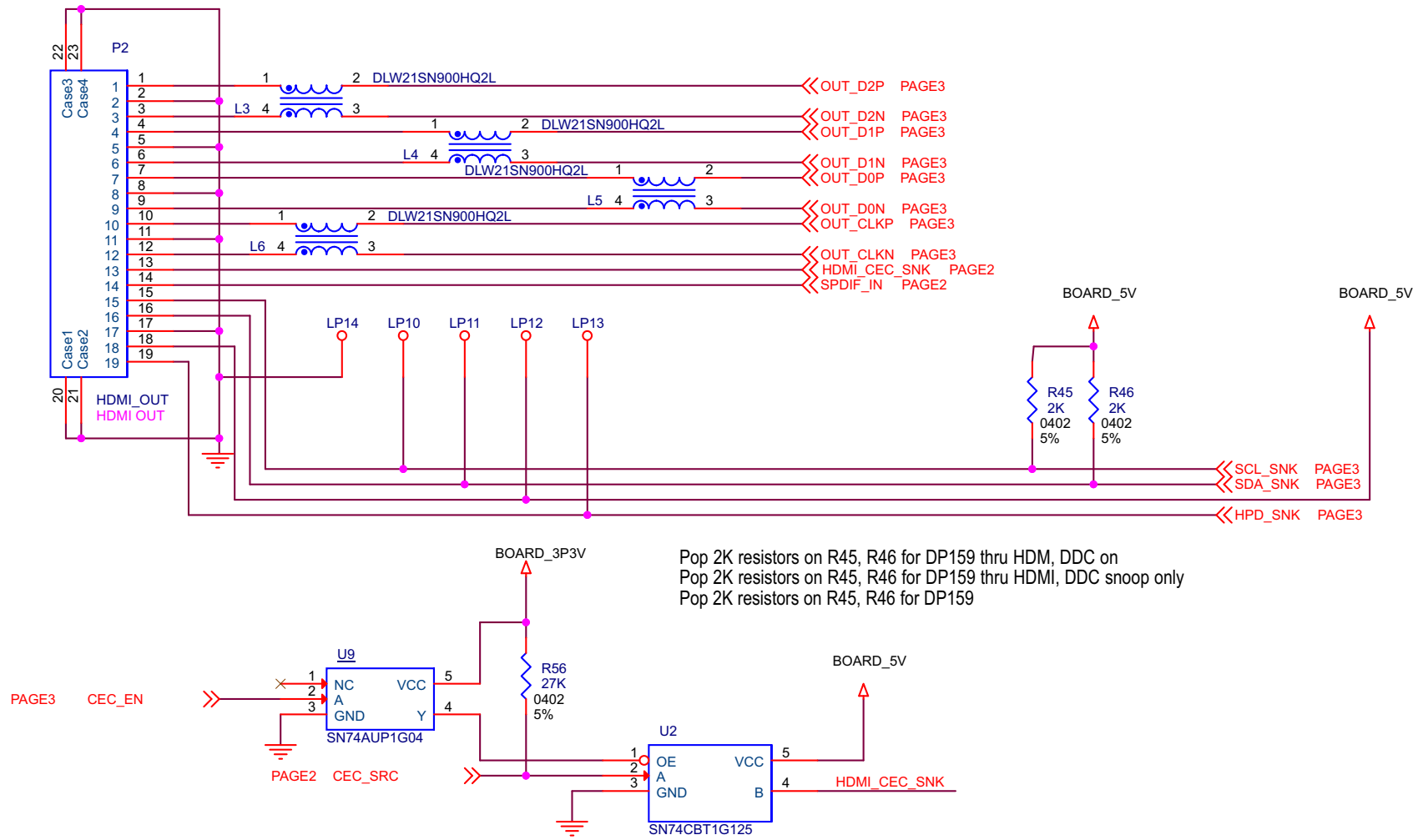

Figure 7. HDMI TX Connector

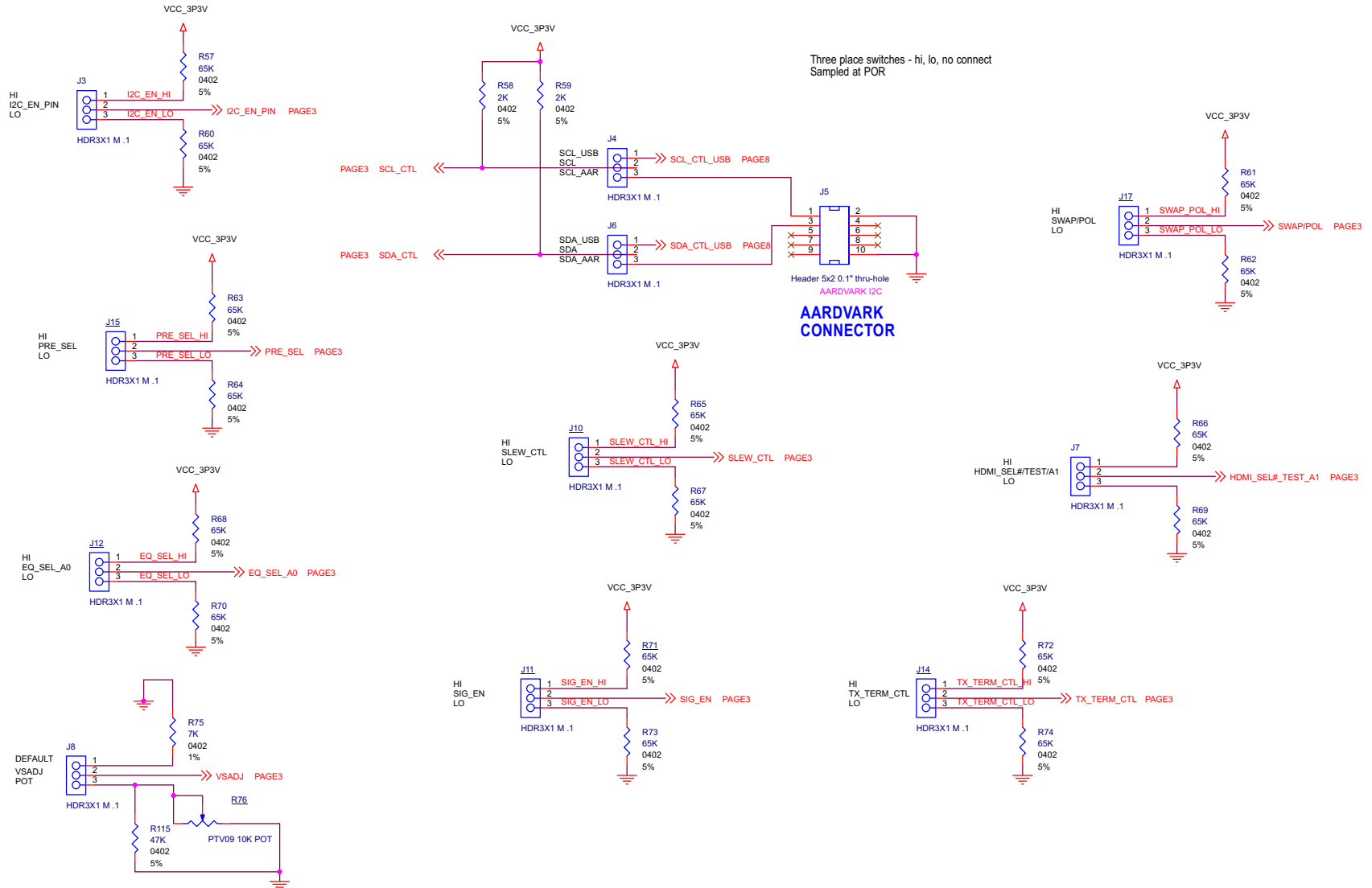

Figure 8. DP159RGZ EVM Select Options

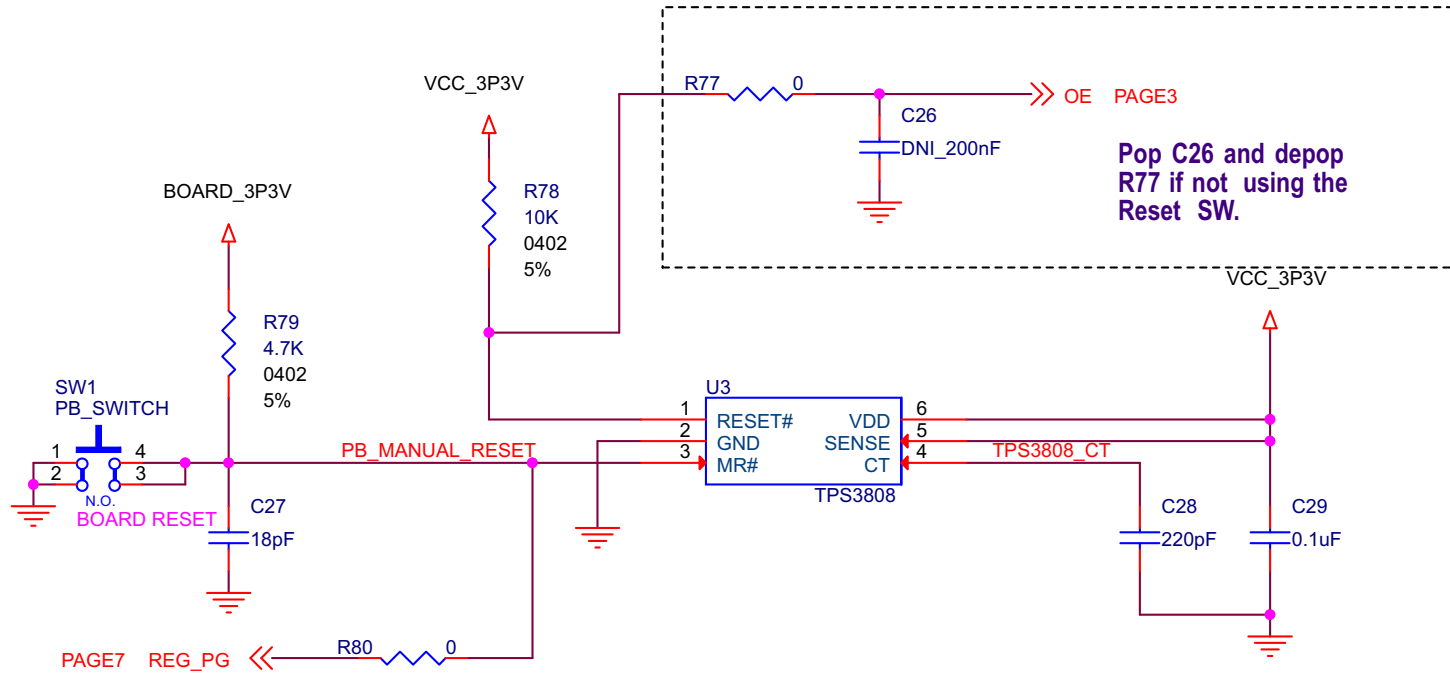

Figure 9. Reset

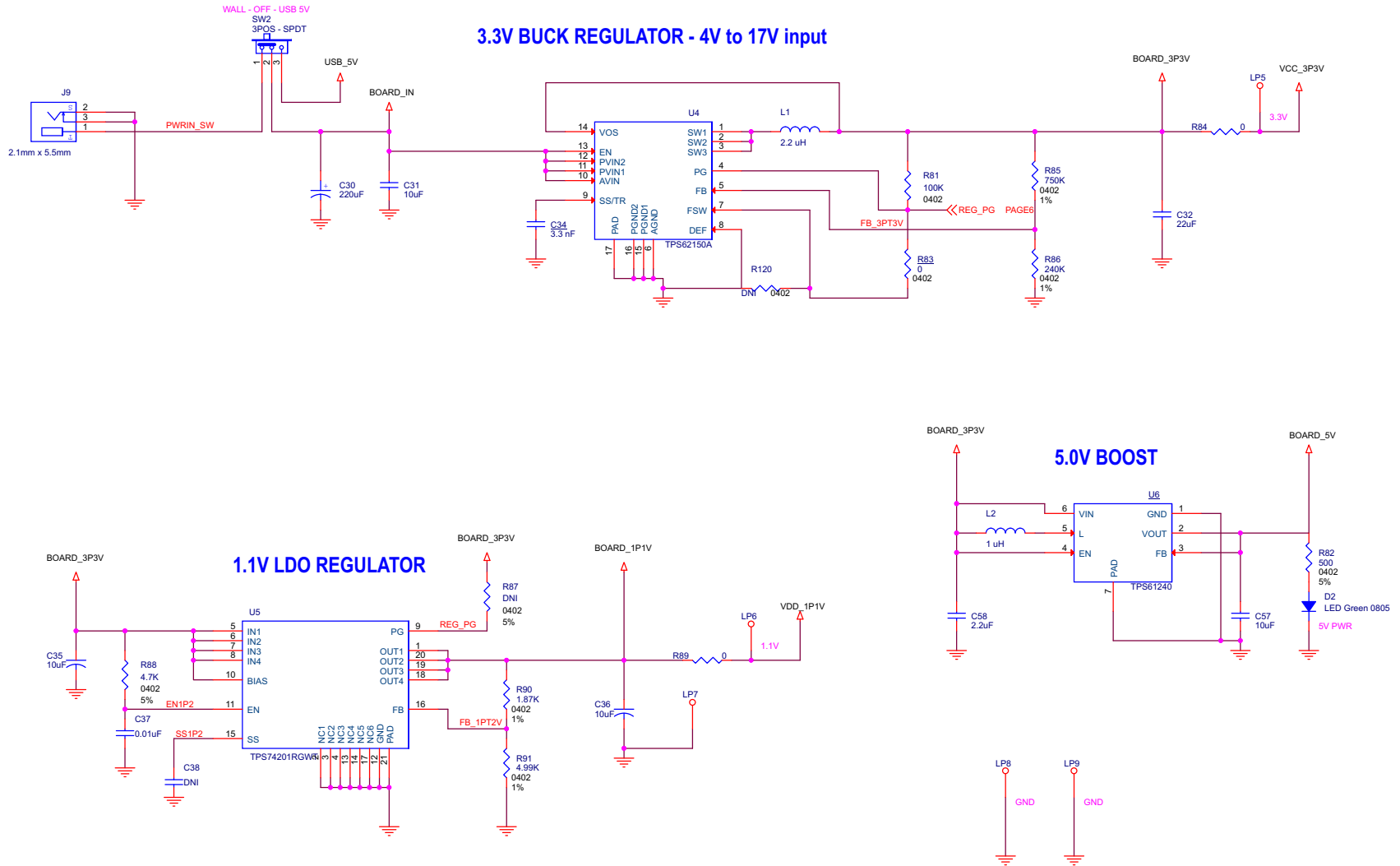

Figure 10. 1.1- and 3.3-V Regulators

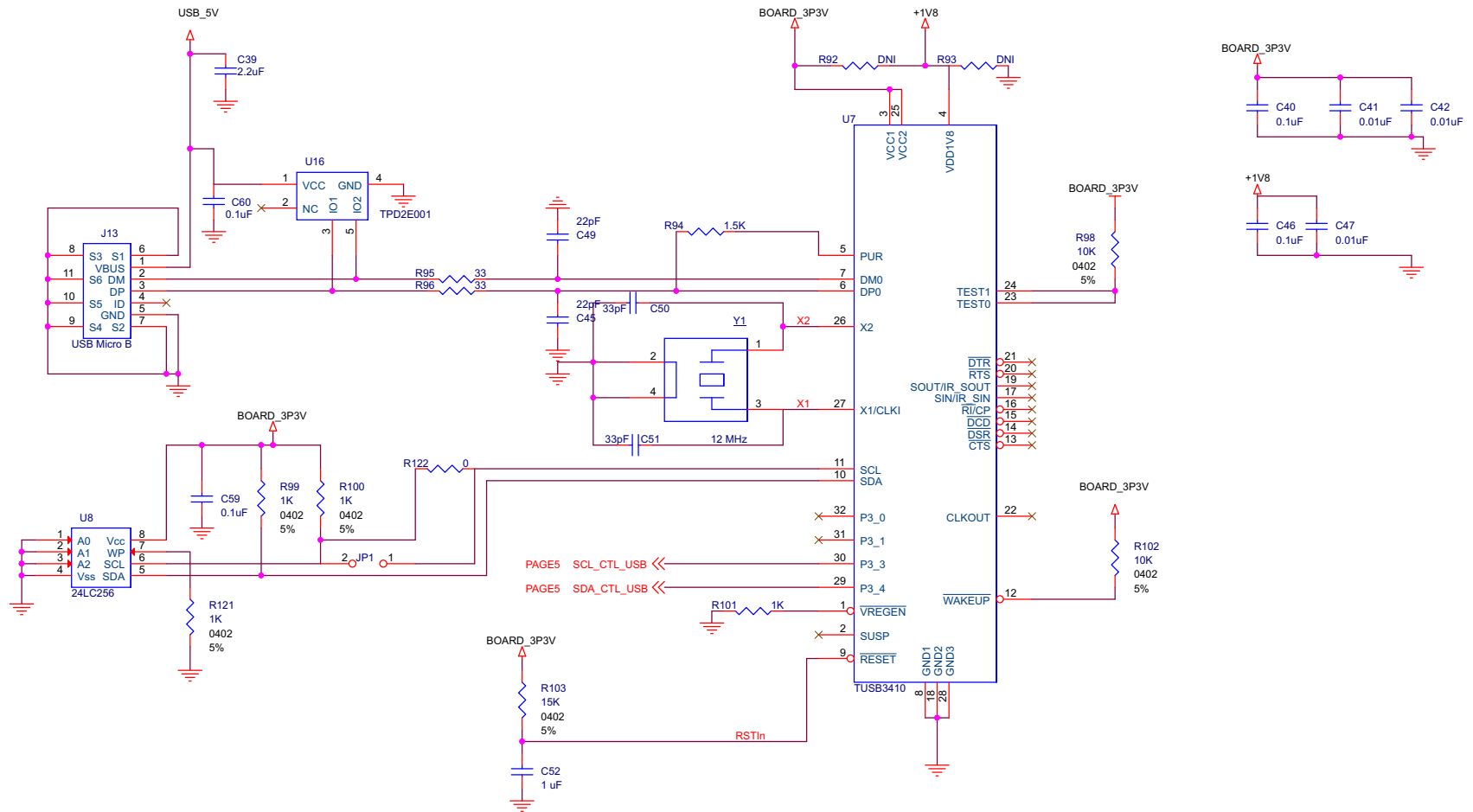

Figure 11. TUSB3410

7 EVM Layout

Figure 12 through Figure 17 illustrate the DP159RGZEVM PCB layouts.

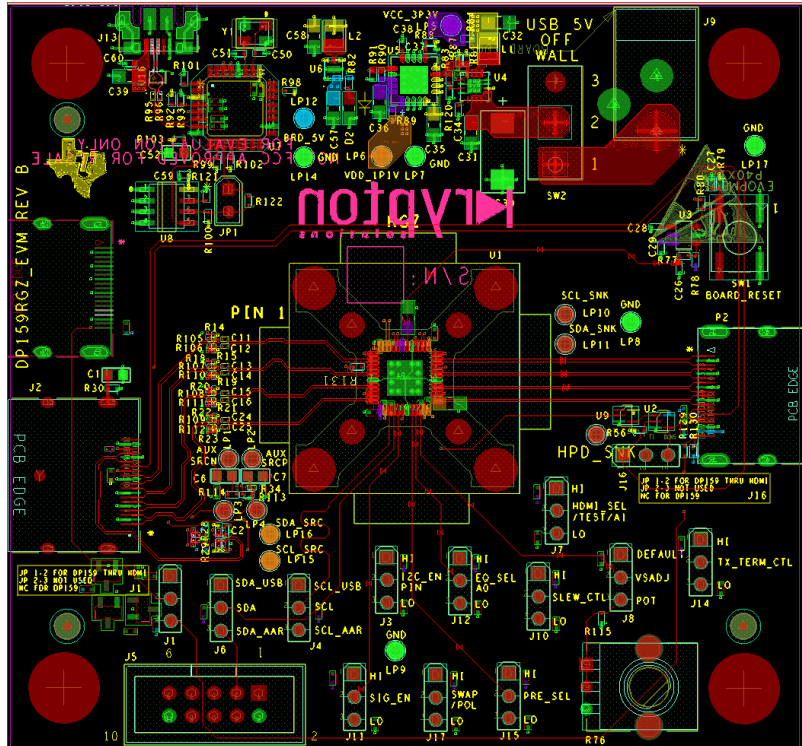

Figure 12. Layer 1 (Top)

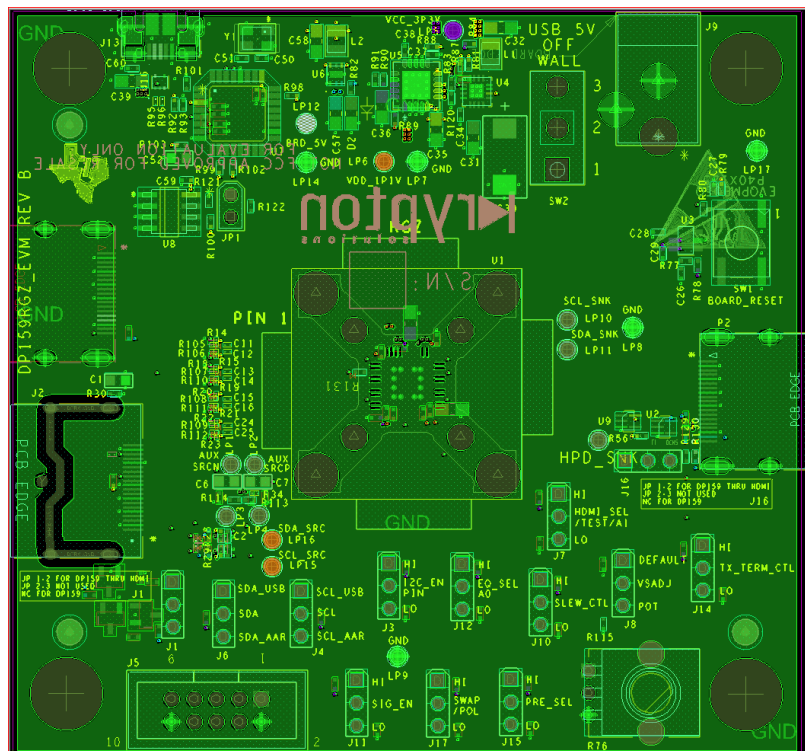

Figure 13. Layer 2 (GND)

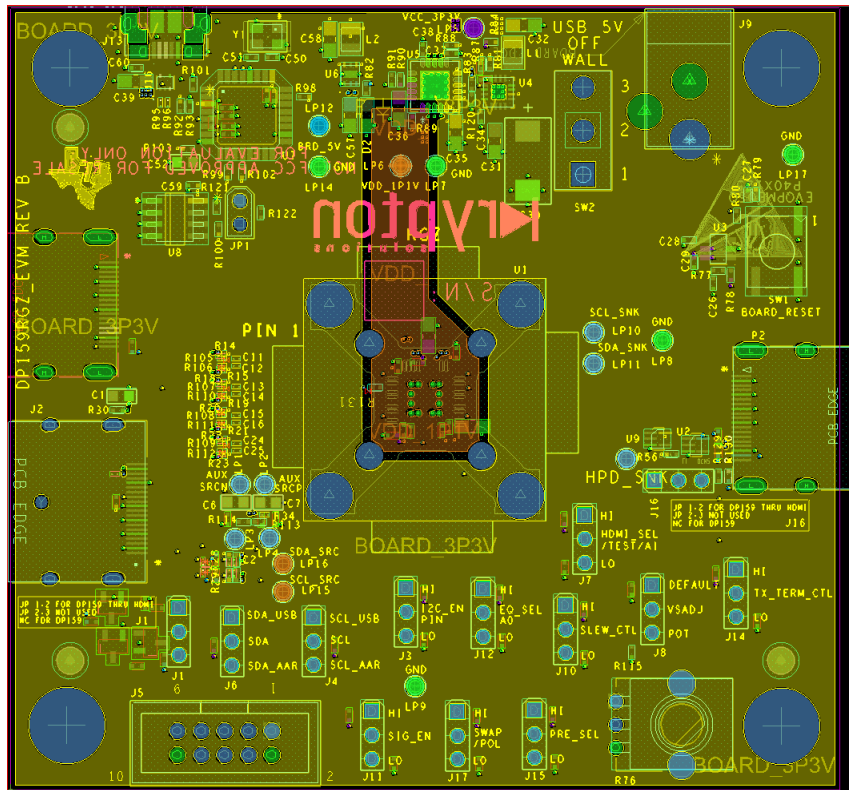

Figure 14. Layer 3 (Power)

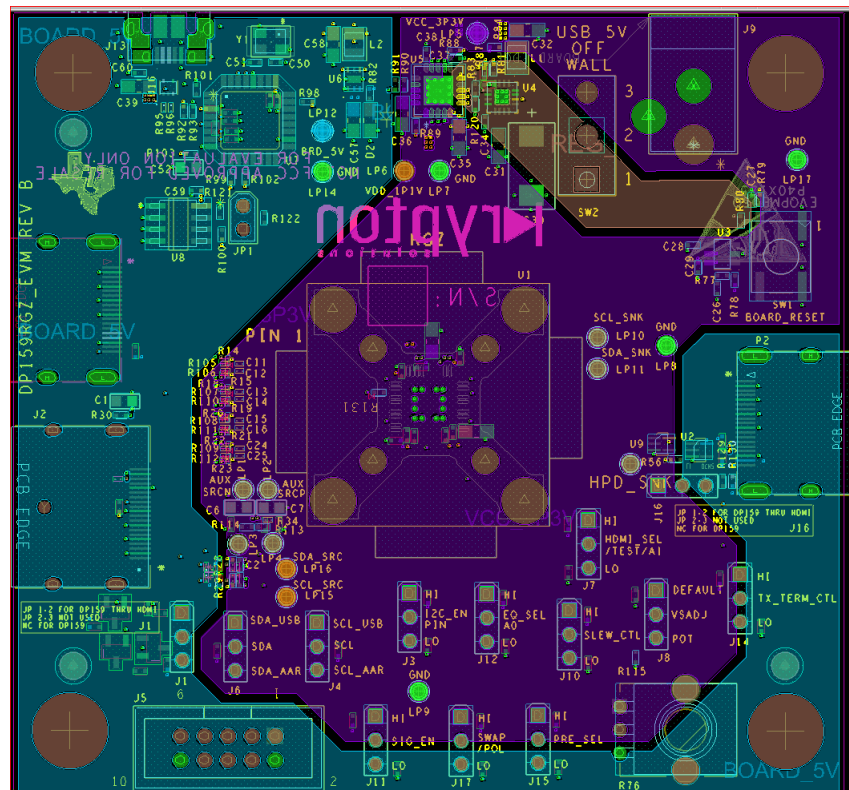

Figure 15. Layer 4 (Power)

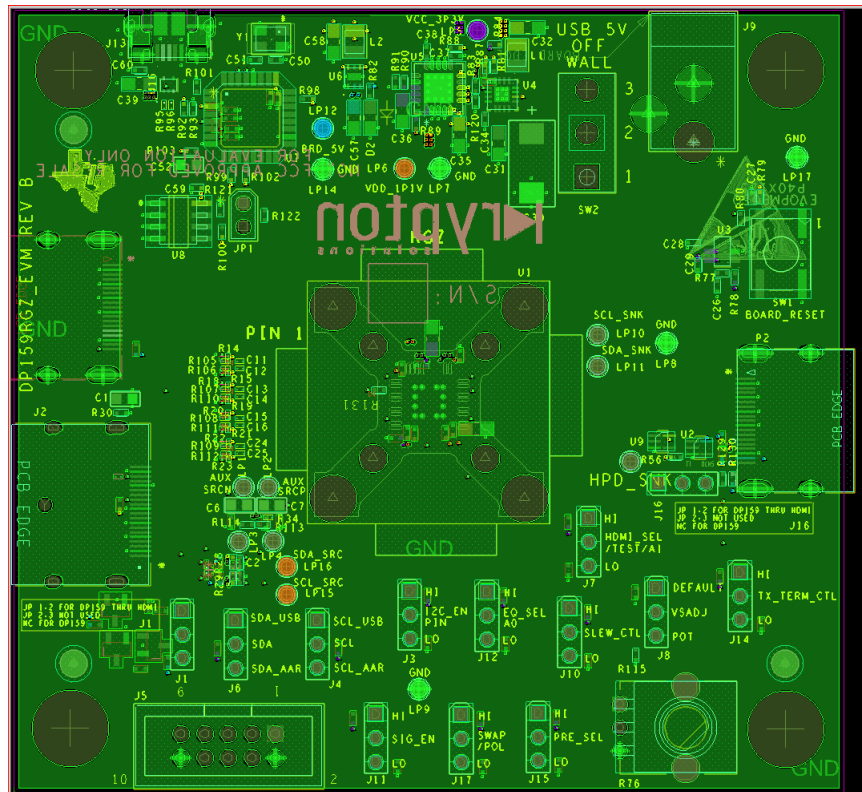

Figure 16. Layer 5 (GND)

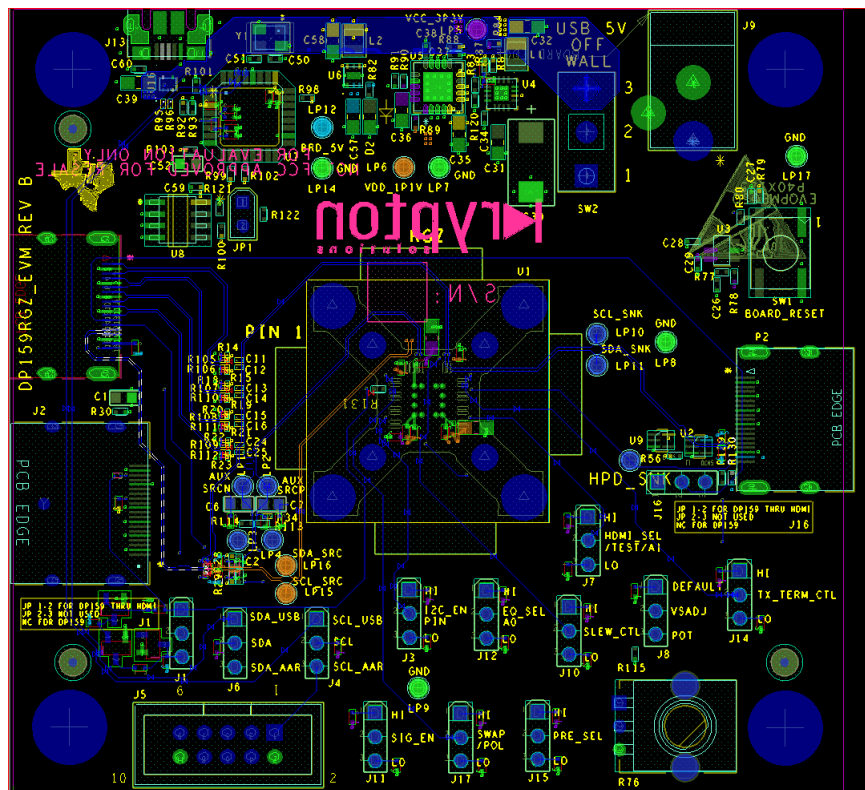

Figure 17. Layer 6 (Bottom)

STANDARD TERMS AND CONDITIONS FOR EVALUATION MODULES

1. *Delivery:* TI delivers TI evaluation boards, kits, or modules, including any accompanying demonstration software, components, or documentation (collectively, an "EVM" or "EVMs") to the User ("User") in accordance with the terms and conditions set forth herein. Acceptance of the EVM is expressly subject to the following terms and conditions.
 - 1.1 EVMs are intended solely for product or software developers for use in a research and development setting to facilitate feasibility evaluation, experimentation, or scientific analysis of TI semiconductor products. EVMs have no direct function and are not finished products. EVMs shall not be directly or indirectly assembled as a part or subassembly in any finished product. For clarification, any software or software tools provided with the EVM ("Software") shall not be subject to the terms and conditions set forth herein but rather shall be subject to the applicable terms and conditions that accompany such Software
 - 1.2 EVMs are not intended for consumer or household use. EVMs may not be sold, sublicensed, leased, rented, loaned, assigned, or otherwise distributed for commercial purposes by Users, in whole or in part, or used in any finished product or production system.
2. *Limited Warranty and Related Remedies/Disclaimers:*
 - 2.1 These terms and conditions do not apply to Software. The warranty, if any, for Software is covered in the applicable Software License Agreement.
 - 2.2 TI warrants that the TI EVM will conform to TI's published specifications for ninety (90) days after the date TI delivers such EVM to User. Notwithstanding the foregoing, TI shall not be liable for any defects that are caused by neglect, misuse or mistreatment by an entity other than TI, including improper installation or testing, or for any EVMs that have been altered or modified in any way by an entity other than TI. Moreover, TI shall not be liable for any defects that result from User's design, specifications or instructions for such EVMs. Testing and other quality control techniques are used to the extent TI deems necessary or as mandated by government requirements. TI does not test all parameters of each EVM.
 - 2.3 If any EVM fails to conform to the warranty set forth above, TI's sole liability shall be at its option to repair or replace such EVM, or credit User's account for such EVM. TI's liability under this warranty shall be limited to EVMs that are returned during the warranty period to the address designated by TI and that are determined by TI not to conform to such warranty. If TI elects to repair or replace such EVM, TI shall have a reasonable time to repair such EVM or provide replacements. Repaired EVMs shall be warranted for the remainder of the original warranty period. Replaced EVMs shall be warranted for a new full ninety (90) day warranty period.
3. *Regulatory Notices:*
 - 3.1 *United States*
 - 3.1.1 *Notice applicable to EVMs not FCC-Approved:*

This kit is designed to allow product developers to evaluate electronic components, circuitry, or software associated with the kit to determine whether to incorporate such items in a finished product and software developers to write software applications for use with the end product. This kit is not a finished product and when assembled may not be resold or otherwise marketed unless all required FCC equipment authorizations are first obtained. Operation is subject to the condition that this product not cause harmful interference to licensed radio stations and that this product accept harmful interference. Unless the assembled kit is designed to operate under part 15, part 18 or part 95 of this chapter, the operator of the kit must operate under the authority of an FCC license holder or must secure an experimental authorization under part 5 of this chapter.
 - 3.1.2 *For EVMs annotated as FCC – FEDERAL COMMUNICATIONS COMMISSION Part 15 Compliant:*

CAUTION

This device complies with part 15 of the FCC Rules. Operation is subject to the following two conditions: (1) This device may not cause harmful interference, and (2) this device must accept any interference received, including interference that may cause undesired operation.

Changes or modifications not expressly approved by the party responsible for compliance could void the user's authority to operate the equipment.

FCC Interference Statement for Class A EVM devices

NOTE: This equipment has been tested and found to comply with the limits for a Class A digital device, pursuant to part 15 of the FCC Rules. These limits are designed to provide reasonable protection against harmful interference when the equipment is operated in a commercial environment. This equipment generates, uses, and can radiate radio frequency energy and, if not installed and used in accordance with the instruction manual, may cause harmful interference to radio communications. Operation of this equipment in a residential area is likely to cause harmful interference in which case the user will be required to correct the interference at his own expense.

FCC Interference Statement for Class B EVM devices

NOTE: This equipment has been tested and found to comply with the limits for a Class B digital device, pursuant to part 15 of the FCC Rules. These limits are designed to provide reasonable protection against harmful interference in a residential installation. This equipment generates, uses and can radiate radio frequency energy and, if not installed and used in accordance with the instructions, may cause harmful interference to radio communications. However, there is no guarantee that interference will not occur in a particular installation. If this equipment does cause harmful interference to radio or television reception, which can be determined by turning the equipment off and on, the user is encouraged to try to correct the interference by one or more of the following measures:

- Reorient or relocate the receiving antenna.
- Increase the separation between the equipment and receiver.
- Connect the equipment into an outlet on a circuit different from that to which the receiver is connected.
- Consult the dealer or an experienced radio/TV technician for help.

3.2 Canada

3.2.1 For EVMs issued with an Industry Canada Certificate of Conformance to RSS-210

Concerning EVMs Including Radio Transmitters:

This device complies with Industry Canada license-exempt RSS standard(s). Operation is subject to the following two conditions: (1) this device may not cause interference, and (2) this device must accept any interference, including interference that may cause undesired operation of the device.

Concernant les EVMs avec appareils radio:

Le présent appareil est conforme aux CNR d'Industrie Canada applicables aux appareils radio exempts de licence. L'exploitation est autorisée aux deux conditions suivantes: (1) l'appareil ne doit pas produire de brouillage, et (2) l'utilisateur de l'appareil doit accepter tout brouillage radioélectrique subi, même si le brouillage est susceptible d'en compromettre le fonctionnement.

Concerning EVMs Including Detachable Antennas:

Under Industry Canada regulations, this radio transmitter may only operate using an antenna of a type and maximum (or lesser) gain approved for the transmitter by Industry Canada. To reduce potential radio interference to other users, the antenna type and its gain should be so chosen that the equivalent isotropically radiated power (e.i.r.p.) is not more than that necessary for successful communication. This radio transmitter has been approved by Industry Canada to operate with the antenna types listed in the user guide with the maximum permissible gain and required antenna impedance for each antenna type indicated. Antenna types not included in this list, having a gain greater than the maximum gain indicated for that type, are strictly prohibited for use with this device.

Concernant les EVMs avec antennes détachables

Conformément à la réglementation d'Industrie Canada, le présent émetteur radio peut fonctionner avec une antenne d'un type et d'un gain maximal (ou inférieur) approuvé pour l'émetteur par Industrie Canada. Dans le but de réduire les risques de brouillage radioélectrique à l'intention des autres utilisateurs, il faut choisir le type d'antenne et son gain de sorte que la puissance isotrope rayonnée équivalente (p.i.r.e.) ne dépasse pas l'intensité nécessaire à l'établissement d'une communication satisfaisante. Le présent émetteur radio a été approuvé par Industrie Canada pour fonctionner avec les types d'antenne énumérés dans le manuel d'usage et ayant un gain admissible maximal et l'impédance requise pour chaque type d'antenne. Les types d'antenne non inclus dans cette liste, ou dont le gain est supérieur au gain maximal indiqué, sont strictement interdits pour l'exploitation de l'émetteur.

3.3 Japan

3.3.1 *Notice for EVMs delivered in Japan:* Please see http://www.tij.co.jp/lstds/ti_ja/general/eStore/notice_01.page 日本国内に輸入される評価用キット、ボードについては、次のところをご覧ください。
http://www.tij.co.jp/lstds/ti_ja/general/eStore/notice_01.page

3.3.2 *Notice for Users of EVMs Considered "Radio Frequency Products" in Japan:* EVMs entering Japan may not be certified by TI as conforming to Technical Regulations of Radio Law of Japan.

If User uses EVMs in Japan, not certified to Technical Regulations of Radio Law of Japan, User is required by Radio Law of Japan to follow the instructions below with respect to EVMs:

1. Use EVMs in a shielded room or any other test facility as defined in the notification #173 issued by Ministry of Internal Affairs and Communications on March 28, 2006, based on Sub-section 1.1 of Article 6 of the Ministry's Rule for Enforcement of Radio Law of Japan,
2. Use EVMs only after User obtains the license of Test Radio Station as provided in Radio Law of Japan with respect to EVMs, or
3. Use of EVMs only after User obtains the Technical Regulations Conformity Certification as provided in Radio Law of Japan with respect to EVMs. Also, do not transfer EVMs, unless User gives the same notice above to the transferee. Please note that if User does not follow the instructions above, User will be subject to penalties of Radio Law of Japan.

【無線電波を送信する製品の開発キットをお使いになる際の注意事項】 開発キットの中には技術基準適合証明を受けていないものがあります。技術適合証明を受けていないものご使用に際しては、電波法遵守のため、以下のいずれかの措置を取っていただく必要がありますのでご注意ください。

1. 電波法施行規則第6条第1項第1号に基づく平成18年3月28日総務省告示第173号で定められた電波暗室等の試験設備でご使用いただく。
2. 実験局の免許を取得後ご使用いただく。
3. 技術基準適合証明を取得後ご使用いただく。

なお、本製品は、上記の「ご使用にあたっての注意」を譲渡先、移転先に通知しない限り、譲渡、移転できないものとします。

上記を遵守頂けない場合は、電波法の罰則が適用される可能性があることをご留意ください。日本テキサス・インスツルメンツ株式会社
東京都新宿区西新宿 6 丁目 2 4 番 1 号
西新宿三井ビル

3.3.3 *Notice for EVMs for Power Line Communication:* Please see http://www.tij.co.jp/llds/ti_ja/general/eStore/notice_02.page
電力線搬送波通信についての開発キットをお使いになる際の注意事項については、次のところをご覧ください。http://www.tij.co.jp/llds/ti_ja/general/eStore/notice_02.page

4 *EVM Use Restrictions and Warnings:*

4.1 EVMS ARE NOT FOR USE IN FUNCTIONAL SAFETY AND/OR SAFETY CRITICAL EVALUATIONS, INCLUDING BUT NOT LIMITED TO EVALUATIONS OF LIFE SUPPORT APPLICATIONS.

4.2 User must read and apply the user guide and other available documentation provided by TI regarding the EVM prior to handling or using the EVM, including without limitation any warning or restriction notices. The notices contain important safety information related to, for example, temperatures and voltages.

4.3 *Safety-Related Warnings and Restrictions:*

4.3.1 User shall operate the EVM within TI's recommended specifications and environmental considerations stated in the user guide, other available documentation provided by TI, and any other applicable requirements and employ reasonable and customary safeguards. Exceeding the specified performance ratings and specifications (including but not limited to input and output voltage, current, power, and environmental ranges) for the EVM may cause personal injury or death, or property damage. If there are questions concerning performance ratings and specifications, User should contact a TI field representative prior to connecting interface electronics including input power and intended loads. Any loads applied outside of the specified output range may also result in unintended and/or inaccurate operation and/or possible permanent damage to the EVM and/or interface electronics. Please consult the EVM user guide prior to connecting any load to the EVM output. If there is uncertainty as to the load specification, please contact a TI field representative. During normal operation, even with the inputs and outputs kept within the specified allowable ranges, some circuit components may have elevated case temperatures. These components include but are not limited to linear regulators, switching transistors, pass transistors, current sense resistors, and heat sinks, which can be identified using the information in the associated documentation. When working with the EVM, please be aware that the EVM may become very warm.

4.3.2 EVMs are intended solely for use by technically qualified, professional electronics experts who are familiar with the dangers and application risks associated with handling electrical mechanical components, systems, and subsystems. User assumes all responsibility and liability for proper and safe handling and use of the EVM by User or its employees, affiliates, contractors or designees. User assumes all responsibility and liability to ensure that any interfaces (electronic and/or mechanical) between the EVM and any human body are designed with suitable isolation and means to safely limit accessible leakage currents to minimize the risk of electrical shock hazard. User assumes all responsibility and liability for any improper or unsafe handling or use of the EVM by User or its employees, affiliates, contractors or designees.

4.4 User assumes all responsibility and liability to determine whether the EVM is subject to any applicable international, federal, state, or local laws and regulations related to User's handling and use of the EVM and, if applicable, User assumes all responsibility and liability for compliance in all respects with such laws and regulations. User assumes all responsibility and liability for proper disposal and recycling of the EVM consistent with all applicable international, federal, state, and local requirements.

5. *Accuracy of Information:* To the extent TI provides information on the availability and function of EVMs, TI attempts to be as accurate as possible. However, TI does not warrant the accuracy of EVM descriptions, EVM availability or other information on its websites as accurate, complete, reliable, current, or error-free.

6. *Disclaimers:*
- 6.1 EXCEPT AS SET FORTH ABOVE, EVMS AND ANY WRITTEN DESIGN MATERIALS PROVIDED WITH THE EVM (AND THE DESIGN OF THE EVM ITSELF) ARE PROVIDED "AS IS" AND "WITH ALL FAULTS." TI DISCLAIMS ALL OTHER WARRANTIES, EXPRESS OR IMPLIED, REGARDING SUCH ITEMS, INCLUDING BUT NOT LIMITED TO ANY IMPLIED WARRANTIES OF MERCHANTABILITY OR FITNESS FOR A PARTICULAR PURPOSE OR NON-INFRINGEMENT OF ANY THIRD PARTY PATENTS, COPYRIGHTS, TRADE SECRETS OR OTHER INTELLECTUAL PROPERTY RIGHTS.
- 6.2 EXCEPT FOR THE LIMITED RIGHT TO USE THE EVM SET FORTH HEREIN, NOTHING IN THESE TERMS AND CONDITIONS SHALL BE CONSTRUED AS GRANTING OR CONFERRING ANY RIGHTS BY LICENSE, PATENT, OR ANY OTHER INDUSTRIAL OR INTELLECTUAL PROPERTY RIGHT OF TI, ITS SUPPLIERS/LICENSORS OR ANY OTHER THIRD PARTY, TO USE THE EVM IN ANY FINISHED END-USER OR READY-TO-USE FINAL PRODUCT, OR FOR ANY INVENTION, DISCOVERY OR IMPROVEMENT MADE, CONCEIVED OR ACQUIRED PRIOR TO OR AFTER DELIVERY OF THE EVM.
7. *USER'S INDEMNITY OBLIGATIONS AND REPRESENTATIONS.* USER WILL DEFEND, INDEMNIFY AND HOLD TI, ITS LICENSORS AND THEIR REPRESENTATIVES HARMLESS FROM AND AGAINST ANY AND ALL CLAIMS, DAMAGES, LOSSES, EXPENSES, COSTS AND LIABILITIES (COLLECTIVELY, "CLAIMS") ARISING OUT OF OR IN CONNECTION WITH ANY HANDLING OR USE OF THE EVM THAT IS NOT IN ACCORDANCE WITH THESE TERMS AND CONDITIONS. THIS OBLIGATION SHALL APPLY WHETHER CLAIMS ARISE UNDER STATUTE, REGULATION, OR THE LAW OF TORT, CONTRACT OR ANY OTHER LEGAL THEORY, AND EVEN IF THE EVM FAILS TO PERFORM AS DESCRIBED OR EXPECTED.
8. *Limitations on Damages and Liability:*
- 8.1 *General Limitations.* IN NO EVENT SHALL TI BE LIABLE FOR ANY SPECIAL, COLLATERAL, INDIRECT, PUNITIVE, INCIDENTAL, CONSEQUENTIAL, OR EXEMPLARY DAMAGES IN CONNECTION WITH OR ARISING OUT OF THESE TERMS AND CONDITIONS OR THE USE OF THE EVMS PROVIDED HEREUNDER, REGARDLESS OF WHETHER TI HAS BEEN ADVISED OF THE POSSIBILITY OF SUCH DAMAGES. EXCLUDED DAMAGES INCLUDE, BUT ARE NOT LIMITED TO, COST OF REMOVAL OR REINSTALLATION, ANCILLARY COSTS TO THE PROCUREMENT OF SUBSTITUTE GOODS OR SERVICES, RETESTING, OUTSIDE COMPUTER TIME, LABOR COSTS, LOSS OF GOODWILL, LOSS OF PROFITS, LOSS OF SAVINGS, LOSS OF USE, LOSS OF DATA, OR BUSINESS INTERRUPTION. NO CLAIM, SUIT OR ACTION SHALL BE BROUGHT AGAINST TI MORE THAN ONE YEAR AFTER THE RELATED CAUSE OF ACTION HAS OCCURRED.
- 8.2 *Specific Limitations.* IN NO EVENT SHALL TI'S AGGREGATE LIABILITY FROM ANY WARRANTY OR OTHER OBLIGATION ARISING OUT OF OR IN CONNECTION WITH THESE TERMS AND CONDITIONS, OR ANY USE OF ANY TI EVM PROVIDED HEREUNDER, EXCEED THE TOTAL AMOUNT PAID TO TI FOR THE PARTICULAR UNITS SOLD UNDER THESE TERMS AND CONDITIONS WITH RESPECT TO WHICH LOSSES OR DAMAGES ARE CLAIMED. THE EXISTENCE OF MORE THAN ONE CLAIM AGAINST THE PARTICULAR UNITS SOLD TO USER UNDER THESE TERMS AND CONDITIONS SHALL NOT ENLARGE OR EXTEND THIS LIMIT.
9. *Return Policy.* Except as otherwise provided, TI does not offer any refunds, returns, or exchanges. Furthermore, no return of EVM(s) will be accepted if the package has been opened and no return of the EVM(s) will be accepted if they are damaged or otherwise not in a resalable condition. If User feels it has been incorrectly charged for the EVM(s) it ordered or that delivery violates the applicable order, User should contact TI. All refunds will be made in full within thirty (30) working days from the return of the components(s), excluding any postage or packaging costs.
10. *Governing Law:* These terms and conditions shall be governed by and interpreted in accordance with the laws of the State of Texas, without reference to conflict-of-laws principles. User agrees that non-exclusive jurisdiction for any dispute arising out of or relating to these terms and conditions lies within courts located in the State of Texas and consents to venue in Dallas County, Texas. Notwithstanding the foregoing, any judgment may be enforced in any United States or foreign court, and TI may seek injunctive relief in any United States or foreign court.

Mailing Address: Texas Instruments, Post Office Box 655303, Dallas, Texas 75265
Copyright © 2015, Texas Instruments Incorporated

IMPORTANT NOTICE

Texas Instruments Incorporated and its subsidiaries (TI) reserve the right to make corrections, enhancements, improvements and other changes to its semiconductor products and services per JESD46, latest issue, and to discontinue any product or service per JESD48, latest issue. Buyers should obtain the latest relevant information before placing orders and should verify that such information is current and complete. All semiconductor products (also referred to herein as "components") are sold subject to TI's terms and conditions of sale supplied at the time of order acknowledgment.

TI warrants performance of its components to the specifications applicable at the time of sale, in accordance with the warranty in TI's terms and conditions of sale of semiconductor products. Testing and other quality control techniques are used to the extent TI deems necessary to support this warranty. Except where mandated by applicable law, testing of all parameters of each component is not necessarily performed.

TI assumes no liability for applications assistance or the design of Buyers' products. Buyers are responsible for their products and applications using TI components. To minimize the risks associated with Buyers' products and applications, Buyers should provide adequate design and operating safeguards.

TI does not warrant or represent that any license, either express or implied, is granted under any patent right, copyright, mask work right, or other intellectual property right relating to any combination, machine, or process in which TI components or services are used. Information published by TI regarding third-party products or services does not constitute a license to use such products or services or a warranty or endorsement thereof. Use of such information may require a license from a third party under the patents or other intellectual property of the third party, or a license from TI under the patents or other intellectual property of TI.

Reproduction of significant portions of TI information in TI data books or data sheets is permissible only if reproduction is without alteration and is accompanied by all associated warranties, conditions, limitations, and notices. TI is not responsible or liable for such altered documentation. Information of third parties may be subject to additional restrictions.

Resale of TI components or services with statements different from or beyond the parameters stated by TI for that component or service voids all express and any implied warranties for the associated TI component or service and is an unfair and deceptive business practice. TI is not responsible or liable for any such statements.

Buyer acknowledges and agrees that it is solely responsible for compliance with all legal, regulatory and safety-related requirements concerning its products, and any use of TI components in its applications, notwithstanding any applications-related information or support that may be provided by TI. Buyer represents and agrees that it has all the necessary expertise to create and implement safeguards which anticipate dangerous consequences of failures, monitor failures and their consequences, lessen the likelihood of failures that might cause harm and take appropriate remedial actions. Buyer will fully indemnify TI and its representatives against any damages arising out of the use of any TI components in safety-critical applications.

In some cases, TI components may be promoted specifically to facilitate safety-related applications. With such components, TI's goal is to help enable customers to design and create their own end-product solutions that meet applicable functional safety standards and requirements. Nonetheless, such components are subject to these terms.

No TI components are authorized for use in FDA Class III (or similar life-critical medical equipment) unless authorized officers of the parties have executed a special agreement specifically governing such use.

Only those TI components which TI has specifically designated as military grade or "enhanced plastic" are designed and intended for use in military/aerospace applications or environments. Buyer acknowledges and agrees that any military or aerospace use of TI components which have **not** been so designated is solely at the Buyer's risk, and that Buyer is solely responsible for compliance with all legal and regulatory requirements in connection with such use.

TI has specifically designated certain components as meeting ISO/TS16949 requirements, mainly for automotive use. In any case of use of non-designated products, TI will not be responsible for any failure to meet ISO/TS16949.

Products

Audio	www.ti.com/audio
Amplifiers	amplifier.ti.com
Data Converters	dataconverter.ti.com
DLP® Products	www.dlp.com
DSP	dsp.ti.com
Clocks and Timers	www.ti.com/clocks
Interface	interface.ti.com
Logic	logic.ti.com
Power Mgmt	power.ti.com
Microcontrollers	microcontroller.ti.com
RFID	www.ti-rfid.com
OMAP Applications Processors	www.ti.com/omap
Wireless Connectivity	www.ti.com/wirelessconnectivity

Applications

Automotive and Transportation	www.ti.com/automotive
Communications and Telecom	www.ti.com/communications
Computers and Peripherals	www.ti.com/computers
Consumer Electronics	www.ti.com/consumer-apps
Energy and Lighting	www.ti.com/energy
Industrial	www.ti.com/industrial
Medical	www.ti.com/medical
Security	www.ti.com/security
Space, Avionics and Defense	www.ti.com/space-avionics-defense
Video and Imaging	www.ti.com/video

TI E2E Community

e2e.ti.com