

LEVO C³

Instruction manual



Please read the Instruction Manual carefully before attempting to use your wheelchair

Alterations in constructional and technical manner or to the electronic require the written authorisation of LEVO AG, otherwise no warranty or product liability will be accepted.

In case of difficulty contact:

Manufacturer:

LEVO AG
Anglikerstrasse 20
CH-5610 Wohlen
Tel: +41 (0)56 618 44 11
Fax: +41 (0)56 618 44 10
Internet: <http://www.levo.ch>

Agent:

Version 1.8

Dear Customer,

We would like to thank you for putting your trust in LEVO stand-up wheelchairs.

The LEVO stand-up wheelchair is a unique aid for use by those facing difficulties walking and standing up. As well as performing all the functions of an active wheelchair, the LEVO enables you to stand up on your own.

Please read these operating instructions carefully before using your LEVO. They contain important information necessary for successful operation of the wheelchair.

Whether you use your LEVO as a stand-up aid at work in everyday life, or to help with standing exercises, it guarantees you optimum independence, mobility and health.

As a LEVO customer, you have a valuable contribution to make to the on-going further development of our products. We put great store by your suggestions, which ensure that LEVO still offers the most comprehensive service available and provides for the widest possible range of needs.

Yours faithfully,

LEVO AG

Content

Declaration of Conformity	6
Warranty	8
1. Intoduction.....	9
2. Safety instructions.....	10
2.1. General safety instructions	10
2.2. Operation	11
2.3. Driving.....	11
2.4. Stand-up function	11
2.5. Safety belt system	12
2.6. Transportation	12
2.7. Servicing and maintenance.....	13
3. Preparing the wheelchair for use and operation	14
3.1. Dispatch and transport.....	14
Initial operation / Main fuse handling in case of replacement, transportation and storage.....	14
3.2. Delivery	15
3.3. Storage.....	15
3.4. First adjustments	15
4. Control unit.....	16
4.1. VR2-control	16
4.1.1. On-/ Off-button.....	16
4.1.2. Battery gauge	16
4.1.3. Joystick.....	17
4.1.4. Speed	17
4.1.5. Change of the seat position	18
4.1.6. Light kit	19
4.1.7. Horn	19
4.1.8. Locking/ unlocking the wheelchair	19
4.2. R-net control (option)	20
4.2.1. On-/ Off-button	20
4.2.2. Battery gauge	20
4.2.3. Joystick	21
4.2.4. Speed	21
4.2.5. Change of the seat position	22
4.2.6. Light Kit.....	22
4.2.7. Horn	23
4.2.8. Locking/ unlocking the wheelchair	23

5. Electromagnetic interference (EMI)	24
6. Driving the wheelchair	26
6.1. Driving in general.....	26
6.2. Obstacles	26
6.3. Permissible inclinations	27
6.4. Unlock the drive brakes	27
6.5. Charging the batteries	27
7. Safety harness	28
7.1. Knee support.....	28
7.1.1. Knee support „Pro“.....	28
7.1.2. Knee support „Integral“	28
7.2. Chest strap.....	28
8. Transfer	30
8.1. Getting into the wheelchair	30
8.2. Getting out of the wheelchair	30
8.3. Sideways transfer	30
9. Individual settings	31
9.1. Adjustment of the seat depth.....	31
9.2. Change of the seat width	32
9.3. Change the distance between the armrests	32
9.4. Adjustment of the backrest angle	32
9.5. Change of the distance footrest - seat cushion and angle adjustment of the footrest.....	33
9.6. Adjustment of the armrest height/angle.....	33
9.7. Adjustment of the armrest length.....	34
9.8. Change the position of the control unit.....	34
9.9. Adjustment of the knee support	34
9.9.1. Knee support „Pro“.....	34
9.9.2. Knee support „Integral“	35
9.10. Adjustment of the backrest height	35
10. Options	36
10.1. Tilt in space	36
10.2. Swing away holder for the Control unit.....	36
10.3. Joystick protection guard.....	36
10.4. Swing away table tray.....	37
10.5. Skirt guard	37
10.6. Upper leg support.....	37
10.7. Chest role.....	38
10.8. Foot guide	38

10.9.	Lamps for outdoor use with indicators	38
10.10.	Jostick-top	39
10.11.	Rear view mirror.....	39
11.	Transportation of your wheelchair.....	40
11.1.	Transportation in a vehicle without the person in the wheelchair	40
11.2.	Transportation in a vehicle with the person in the wheelchair	42
12.	Cleaning.....	42
13.	Maintenance	43
13.1.	Service.....	43
13.2.	Safety checks	43
13.2.1.	Daily checks.....	43
13.2.2.	Weekly checks	44
13.3.	Spare parts.....	44
14.	Disposal.....	45
15.	Trouble shooting.....	46
16.	Controller self help guide VR2	47
17.	Controller self help guide R-net	48
18.	Technical information	49
19.	Version-Management.....	50

Declaration of Conformity

As manufacturer of the LEVO Stand-up wheelchair, the company

LEVO AG

Anglikerstrasse 20
CH-5610 Wohlen, Switzerland
Tel.: +41 (0)56-618 4411
Fax: +41 (0)56-618 4410
Internet: <http://www.levo.ch>

Declares in all responsibility that the product hereby mentioned (see following list) corresponds with the valid direction of the EC instructions for medical products determined 14th June, 1993 (93/42/EWG).

This Declaration of Conformity of the LEVO C³ includes all its accessories and options available from LEVO.

ISO 7176-1:1999	Wheelchairs - Part 1: Determination of static stability
ISO 7176-2:2001	Wheelchairs - Part 2: Determination of dynamic stability of electric wheelchairs
ISO 7176-3:2003	Wheelchairs - Part 3: Determination of efficiency of brakes
ISO 7176-4:1997	Wheelchairs - Part 4: Energy consumption of electric wheelchairs and scooters for determination of theoretical distance range
ISO 7176-5:1986	Wheelchairs - Part 5: Determination of overall dimensions, mass and turning space
ISO 7176-6:2001	Wheelchairs - Part 6: Determination of maximum speed, acceleration and deceleration of electric wheelchairs
ISO 7176-8:1998	Wheelchairs - Part 8: Requirements and test methods for static, impact and fatigue strengths
ISO 7176-9:2001	Wheelchairs - Part 9: Climatic tests for electric wheelchairs
ISO 7176-10:1988	Wheelchairs - Part 10: Determination of obstacle climbing ability of electric wheelchairs
ISO 7176-11:1992	Wheelchairs - Part 11: Test dummies
ISO 7176-13:1989	Wheelchairs - Part 13: Determination of coefficient of friction of test surfaces
ISO 7176-14:1997	Wheelchairs - Part 14: Power and control systems for electric wheelchairs - Requirements and test methods
ISO 7176-15:1996	Wheelchairs - Part 15: Requirements for information disclosure, documentation and labelling
ISO 7176-16:1997	Wheelchairs - Part 16: Resistance to ignition of upholstered parts - Requirements and test methods
ISO 8191-1:1987	Furniture - Assessment of the ignitability of upholstered furniture - Part 1: Ignition source: smouldering cigarette
ISO 8191-2:1988	Furniture - Assessment of ignitability of upholstered furniture - Part 2 : Ignition source : match-flame equivalent
ISO 10993-5:1999	Biological evaluation of medical devices - Part 5: Tests for In Vitro

- ISO 14971:2007 Medical devices - Application of risk management to medical devices
- EN 12184:2004 Electrically powered wheelchairs, scooters and their chargers
- EN 12182:1999 Technical aids for disabled persons. General requirements and test methods
- ISO 7176-21:2003 Wheelchairs - Part 21: Requirements and test methods for electromagnetic compatibility
- EN 61000-3-2:2006 Limits – Limits for harmonic current emissions
- EN 61000-3-3:1995+A1:2001 +A2:2005
Electromagnetic compatibility (EMC). Limits. Limitation of voltage changes, voltage fluctuations and flicker in public low-voltage supply systems, for equipment with rated current less or equal 16 A per phase and not subject to conditional connection
- CISPR 11:2003+A1:2004
Industrial, scientific and medical (ISM) radio-frequency equipment -
Electromagnetic disturbance characteristics - Limits and methods of measurement
- EN 61000-4-11:2004 Electromagnetic compatibility (EMC). Testing and measurement techniques. Voltage dips, short interruptions and voltage variations immunity tests
- EN 61000-4-5:2006 Surge Immunity testing
- EN 61000-4-4:2004 Electrical fast transient/burst immunity test
- EN 61000-4-2:1995+A1:1998+A1:2001
Electrostatic discharge immunity test
- EN 61000-4-6:1996+A1:2001
Immunity to conducted disturbances, induced by radio-frequency fields
- EN 61000-4-3:2006 Radiated, radio-frequency, electromagnetic field immunity test
- ISO WC/Volume1:1998 Section 7:
Method of Measurement of Seating and Wheel Dimensions
- ISO WC/Volume1:1998 Section 20:
Determination of the performance of stand-up wheelchairs
- ISO WC/Volume1:1998 Section 22:
Set up procedures
- ISO WC/Volume1:1998 Section 93:
Maximum overall dimensions

Type of power stand-up wheelchair:

LEVO C³	S-XL
52Ah and 73Ah battery capacity Incl. Its options and accessories	

Wohlen, January 1, 2010

Thomas Nietlisbach

Thomas Räber

Warranty

Your **LEVO** product is guaranteed from the date of purchase for:

- **Two years** covering all material and manufacturing defects of mechanical parts.
- **One year** covering all electronic components including the motors.
- **Batteries are excluded from the warranty.**

LEVO AG will not repair or replace free of charge any part or parts found to be defective due to abuse, misuse or lack of maintenance.

The customer has no claim on warranty, if there has been any design modifications (mechanic or electronic) been made on the wheelchair without the approval from **LEVO AG**.

Warranty claims should be directed to:

- In Switzerland LEVO AG
- Other Countries To your local agent

Addresses and telephone numbers are given on the front page.

1. Introduction

Thank you to choose the **LEVO C³**.

The **LEVO C³** has been designed as a powered stand-up wheelchair for indoor and outdoor use. As such it belongs to the wheelchair category B.

The **LEVO C³** makes it possible to stand-up and to drive in a standing as well as in a sitting position. This function provides great independence to the user.

This wheelchair is made for everyone whose muscles do not support them to propel a wheelchair manually. The **LEVO C³** is a unique aid for those facing difficulties in standing and walking.

The **LEVO C³** has been designed for older children and adults who will benefit from motorised mobility and the ability to stand up at will.

The standard model of the **LEVO C³** allows comfortable sitting and standing on every stage between the sitting and the complete standing position. Driving is possible in all stages.

The front wheels are permanent powered with the same speed as the middle wheels, which offers a great maneuverability around ramps, obstacles and uneven ground (4WD). In sitting configuration, the chair is driven by the middle wheels and the front wheels are lifted up from the floor which causes a very small turning circle. In standing configuration, the chair is driven by the front wheels and the middle wheels are lifted up from the floor. This allows also a great mobility in standing position. In sitting or standing position, the driven wheels are directly in the centerline of the body.

The seat depth, the armrests and the knee support are stage less adjustable, this gives an ideal possibility to adjust the chair to the customers' needs.

The maximum load weight is 140 kilograms or 310 pounds; this includes all personal belongings carried along too.

Read the safety instructions first, to acquaint yourself with the risks and dangers that can occur by the use of the wheelchair.

The **LEVO C³** is certificated with the **CE** -sign. This product corresponds to the regulations notified as **93/42 EWG**.

If we use the male form in the following, the female form is included in this.

All information, images, pictures and specifications were made on the base of the product information we had at the point in time when we printed the manual. The images and pictures are type examples they don't claim to be exact reproductions of the various parts of the wheelchair.

We reserve ourselves the right to changes of product without previous announcement.

2. Safety instructions

2.1. General safety instructions

For your own security we recommend to read and obey all the instructions carefully in this manual.

LEVO AG is not responsible for damages to persons or property, who resulted from the fact that the user or another person ignored the recommendations, warnings and instructions specified in this manual.

Before using the **LEVO C³**, have your **LEVO** dealer explain the instructions to you. It also helps if you have a friend to listen as well. Study the instruction manual yourself or if you cannot understand it, get a friend to help you doing so. Don't hesitate to ask for any explanation.

On the **LEVO C³** you find the following symbols attached:



Warning, risk of pinching! Make sure no parts of the body, clothing or other items get jammed



Warning, read user's manual!



Anchorage point for the tie down straps.

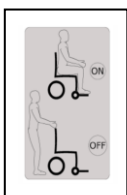

Label for the shutdown of the brake release

2.2. Operation

Never switch off the joystick module during driving. Otherwise the wheelchair will stop abrupt, so that you run the risk, to be thrown forward from the wheelchair. Just release the joystick to stop the wheelchair from moving.

Be aware of, that your wheelchair can produce electromagnetic emissions and disturb other devices

If unintended movement or brake release occurs, turn the wheelchair OFF as soon as it is safe.

2.3. Driving

The **LEVO C³** is designed for outdoor and indoor use.

- Whenever you are driving, use the knee support and the chest belt.
- LEVO** does not recommend driving the **LEVO C³** on uneven, soft or steeply sloping ground.
- Using the **LEVO C³** outdoors, switch on the lights at dawn and dusk and in the dark of course.

Don't let children drive with the wheelchair without supervision.

Avoid driving through puddles with the **LEVO C³**. The wheelchair and especially electrical components are very sensitive to too much water, some splashes of water don't harm. (There is a danger of false function regarding some electrical parts getting too wet.)

The wheelchair is not designated to take along passengers, independently from the age of the driver.

Look further ahead while driving, so that you have sufficient time to react to obstacles and avoid accidents in your way.
Pay attention to pedestrians, children, dogs etc. close to and especially in front of you, since they can stop suddenly or change the direction.

Consider the road permission regulations; these are different from country to country. It is usually prescribed by law, which kind of streets can be used for your purposes. Inquire in this regards at your road traffic licensing department.

Avoid steep edges, hillside situations or stairs if you push the chair manually (brake release lever in lower position), because there is a risk to lose the control over the wheelchair because of its weight and measurements. There is even the risk that the user can fall out of the wheelchair. To overcome an obstacle we recommend, using a ramp or an elevator.

The necessary force to push the **LEVO C³** manually is higher than you are used to with other powered wheelchairs. Depending on the floor surface and the constitution of the person which is pushing the wheelchair, it can be helpful to have a second person around, to help pushing the wheelchair if necessary.

You should under no circumstances attempt to stand up without following all safety precautions.

Standing up stresses your body in ways you may not be used to. Therefore we recommend, consulting your doctor or physical therapist before using the standing function of the **LEVO C³**.

The **LEVO C³** is only allowed to bring you into the stand-up position when the free wheel device is "ON", this guarantees the motor brakes function correctly. Do not stand-up while the chair is in "free wheel" configuration!

You should only bring the **LEVO C³** into standing position, if the chair is on even, solid ground. If this condition is not ensured, the danger of tilting exists.

It is not recommended to drive long distances in the standing position in outdoor areas. This function is meant for moving around standing indoors, as in the kitchen or in the office for examples.

We recommend to stand-up only when in company in case of sudden spasticity, convulsions and similar problems.

2.5. Safety belt system

It's absolutely essential to mount the knee support and the chest belt correct before you use the stand-up function or you are driving (see chapter 5.).

The chest belt is exclusively intended to hold the torso of the user while driving and the stand-up function. It is not used to be a protection device at collisions and/or accidents.

2.6. Transportation

Do not lift the wheelchair at mobile parts. This can lead to damages to property or person and/or damages at the wheelchair.

2.7. Servicing and maintenance

The **LEVO C³** is a complicated piece of machinery. Do not attempt to maintain it yourself. For all maintenance work, please contact an authorized dealer. It is requested that your authorized dealer is in charge to services the wheelchair once every year.

You should only use original **LEVO** spare parts at possible repairs or modifications. If you use other parts, the function and the security of the wheelchair can be influenced. This also means that the wheelchair is no longer covered under warranty.

Programming should only be conducted by healthcare professionals within depth knowledge of PG Drives electronic control systems. Incorrect programming could result in an unsafe set-up of a wheelchair for the user. **LEVO** accepts no liability for losses of any kind if the drive or stability characteristics of the wheelchair are altered without prior notification and discussion with **LEVO**.

All inappropriate changes of the wheelchair and its different systems can lead to an increased accident risk.

All changes and interventions have to be made by an authorized dealer, if you're unsecure about any issue, please ask your dealer first.

3. Preparing the wheelchair for use and operation

3.1. Dispatch and transport

For delivering **LEVO** wheelchairs they are packed in a cardboard box. The back is detached and carefully packed. Particularly delicate parts have extra protection to avoid any damage that could be caused by transportation. All wheelchairs are transported by lorry or air freight. To ensure no damage during transport the main fuse is taken / switched off.

Initial operation / Main fuse handling in case of replacement, transportation and storage

Installation of the main fuse

Fuse version since April 2011

Before shipping, the 70A main fuse is taken off. Before using the chair the main fuse has to be inserted. You shall do this also when travelling by air with this wheelchair.



The main fuse housing is under the chair cover in the rear. To get access, carefully open the cover as shown above.



Open the fuse cover, insert the fuse which is delivered in a separate plastic bag and snap the fuse cover back. Now the chair can be brought into standing position to get access to the fuse cabling. Store the fuse cabling properly above the batteries and the main fuse housing below the control system under the chairs cover.

Activating of the main fuse

Cut out version until March 2011

To activate the main fuse, push the button of the cut out in

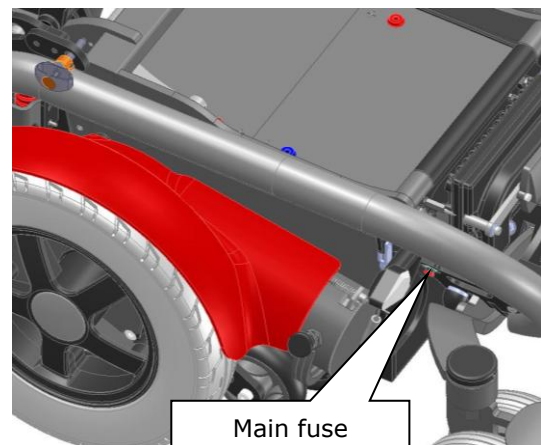

3.2. Delivery

Because of the complex nature of this wheelchair it will be delivered and demonstrated to you by your local agent.

The wheelchair comprises the following components:

	Component	Quantity
1.	Wheelchair base	1
2.	Seat unit	1
3.	Backrest unit	1
4.	Knee support	1
5.	Chest strap	1
6.	Joystick unit	1
7.	Joystick Module	1
8.	Set of batteries	1
9.	Battery charger	1
10.	Tool set	1
11.	Options and accessories	Corresponding to order form

3.3. Storage

The ideal condition to store the **LEVO C³** is a temperature between – 40° and + 60° Celsius (between -30° and +140° Fahrenheit). The humidity should not be above 90%. Please take care to guarantee these mentioned conditions to provide a long life time for the **LEVO C³**.

That the batteries don't discharge too fast, we recommend to taken respectively switch off the main fuse (see 3.1.). We also recommend charging the batteries at least every 2 months if the chair is not used.

3.4. First adjustments

Because the **LEVO C³** was ordered with your personal measurements, it should fit your personal constitution when the chair is delivered to you. If there should be any variations, please take a look at chapter 8. there you can see how the different elements can be adjusted.

Your local agent is responsible to do the final tuning of the adjustment. Therefore take your time at delivery of the chair to assure the chair fits correctly.

4. Control unit

4.1. VR2-control



On the control unit you can find a joystick, buttons and symbols, where we take a closer look at in the following.

4.1.1. On-/ Off-button

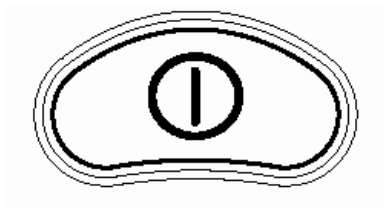

With the On-/ Off-button the chair can be turned on or switched off. Don't use this button to stop the wheelchair, unless there is an emergency.

4.1.2. Battery gauge

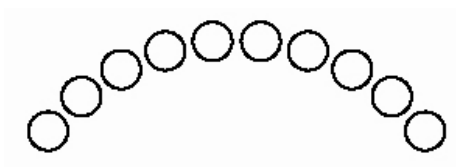

The battery gauge shows you that the wheelchair is switched on and it shows you how much power there is left in the batteries. The gauge is also used as an electronic fault detection (see chapter 16.)

4.1.3. Joystick

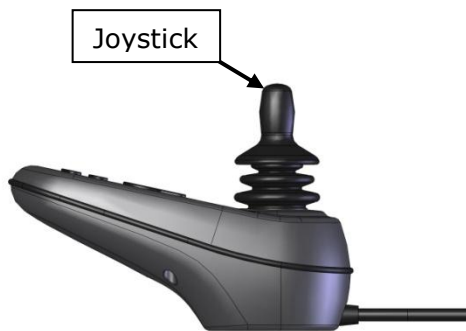

The joystick controls the direction and speed of the wheelchair.

To drive forwards push the joystick forwards. The further you push it from the centre the faster the wheelchair will move. Let go of the joystick and the wheelchair will stop and the brakes come on.

For backwards driving push the joystick backwards. Pushing the joystick to the right side means a right hand curve as a reaction. Pushing the joystick to the left then the chair will drive to the left hand side.

The joystick can be used to choose and to move the actuators as well (see chapter 4.1.5.).

4.1.4. Speed

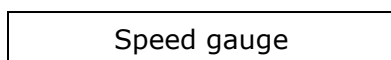

This is a gauge that shows the maximum speed setting for the wheelchair. This gauge also indicates if the speed of the wheelchair is being limited or if the control system is locked.

If one LED is illuminated, you drive with the slowest speed, 5 illuminated LED's mean that you drive with the highest programmed speed.

If the LED's are flashing, it means the speed is reduced. That happens when you go into standing position.

If the LED's are ripple up and down, it means the chair is locked.

4.1.5. Change of the seat position

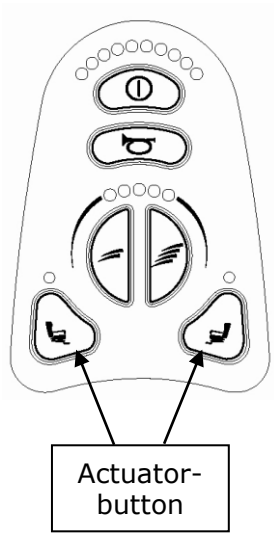

Standard chair without light:

By pressing the left actuator-button, you can activate the stand-up function. If you move the joystick forward, the chair is rising upwards, if you move the joystick backwards, the chair is moving downwards.

If your chair is equipped with the option "Tilt in space", it can be activated by pressing the right actuator-button. If you move the joystick backwards, the complete seat is tilting backwards, if you press the joystick forward, the seat is moving back to the horizontal position.

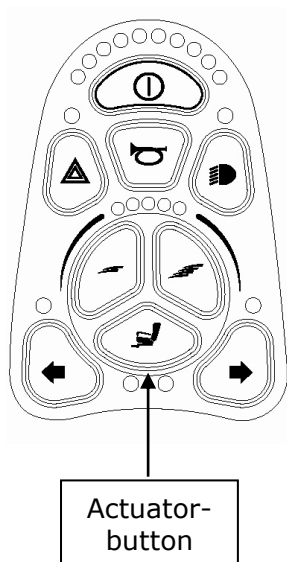

Chair with light:

If your chair is equipped with light, you just have one button to choose the actuators. To activate the stand-up function, press the actuator-button, deflect the joystick to the left, until the left LED under the actuator-button is illuminated. Now you can move the joystick forward to bring the chair into the stand-up position, to go down into the seating position, you just need to move the joystick backwards.

If you have the option "Tilt in space" on your chair, to choose this actuator, press the actuator-button and move the joystick to the right, until the right LED is illuminated. If you move the joystick backwards, the complete seat is tilting backwards, if you press the joystick forward, the seat is moving back to the horizontal position.

4.1.6. Light kit

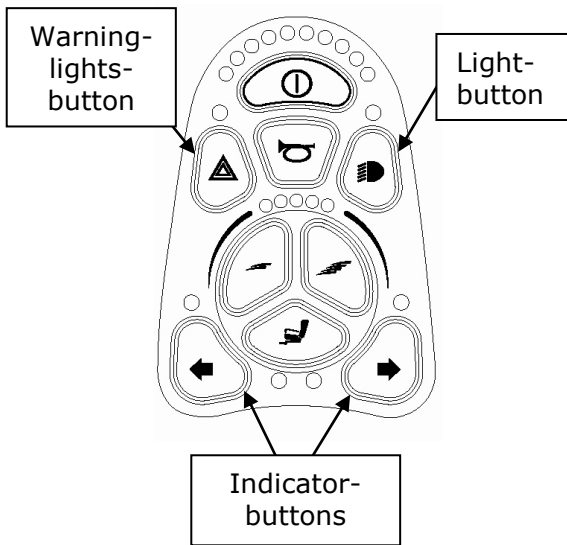

If you chose the option light for your chair, the keypad looks like it's shown on the left.

To activate the light, press the light-button, you switch on the two front and the two rear lights on your chair with this.

To notify that you like to turn to the left, press the left indicator-button, to announce that you like to turn to the right, press the right indicator-button. If you have a breakdown or you would like to call attention to you, you can activate all indicators at the same time with the warning-lights-button.

4.1.7. Horn



The horn will sound while this button is depressed.

4.1.8. Locking/ unlocking the wheelchair

The VR2 control system can be locked to prevent unauthorized use. The locking method is via a sequence of key presses and joystick movements, as detailed below:

To lock the wheelchair:

- While the control system is switched on, depress and hold the on/off button.
- After 1 second the control will beep. Now release the on/off button.
- Deflect the joystick forwards until the control system beeps.
- Deflect the joystick in reverse until the control system beeps.
- Release the joystick, there will be a long beep.
- The wheelchair is now locked.

To unlock the wheelchair:

- Use the on/off button to switch the control system on. The speed indicator will be rippling up and down.
- Deflect the joystick forwards until the control system beeps.
- Deflect the joystick in reverse until the control system beeps.
- Release the joystick, there will be a long beep.
- The wheelchair is now unlocked.

4.2. R-net control (option)



On the control unit you can find a joystick, buttons and a LCD-display, where we take a closer look at in the following.

4.2.1. On-/ Off-button



With the On-/ Off-button the chair can be turned on or switched off. Don't use this button to stop the wheelchair, unless there is an emergency.

4.2.2. Battery gauge



This gauge is only visible on the display, if the control is turned on. It shows you how much power there is left in the batteries. If the gauge starts to flash, it means the chair is still working correct, but the batteries should be charged very soon.

4.2.3. Joystick

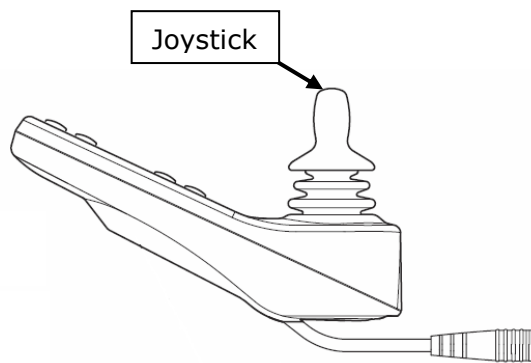

The joystick controls the direction and speed of the wheelchair.

To drive forwards push the joystick forwards. The further you push it from the centre the faster the wheelchair will move. Let go of the joystick and the wheelchair will stop and the brakes come on.

For backwards driving push the joystick backwards. Pushing the joystick to the right side means a right hand curve as a reaction. Pushing the joystick to the left then the chair will drive to the left hand side.

The joystick can be used to choose and to move the actuators as well (see chapter 4.2.5.).

4.2.4. Speed

Speed gauge



Speed buttons



4.2.5. Change of the seat position

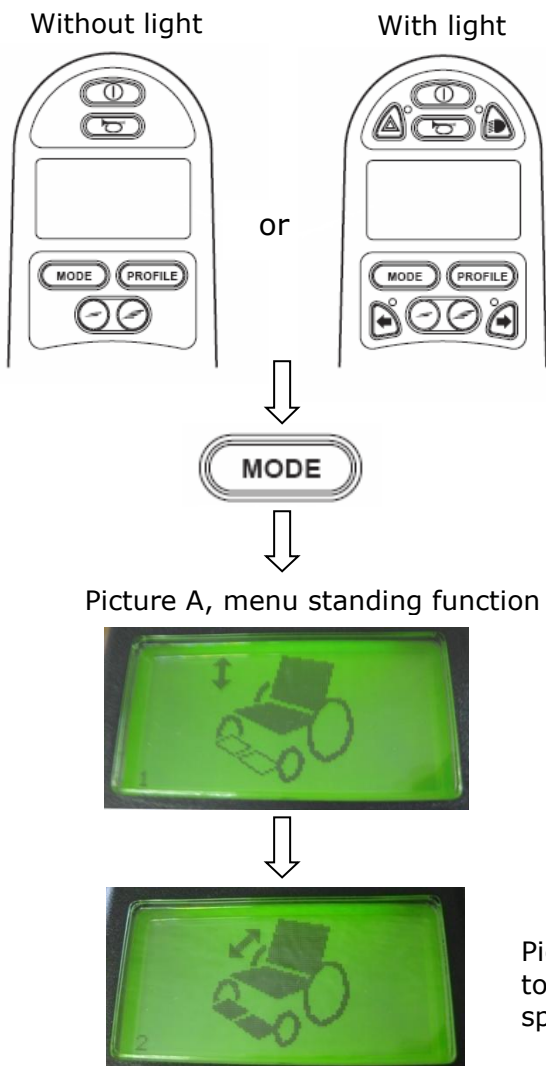

By pressing the MODE-button, you get into the standing function menu (picture A should appear on the display). If you now press the joystick forward, the seat is raising, if you press the joystick backwards, the seat is lowering.

If your chair is equipped with the option "Tilt in space", you can choose this function in the standing menu too, by pressing the joystick to the left or right (picture B should appear on the display). If you pull the joystick backwards, the complete seat is tilting backwards, if you press the joystick forward, the seat is moving back into the horizontal position.

The standing or the tilt motion can be stopped and fixed at any time.

4.2.6. Light Kit

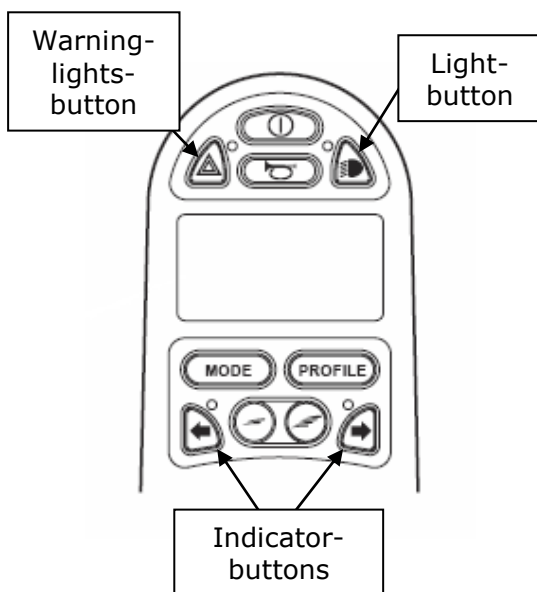

If you choose the option light for your chair, the keypad looks like it's shown on the left.

To activate the light, press the light-button, you switch on the two front and the two rear lights on your chair with this.

To notify that you like to turn to the left, press the left indicator-button, to announce that you like to turn to the right, press the right indicator-button. If you have a breakdown or you would like to call attention to you, you can activate all indicators at the same time with the warning-lights-button.

4.2.7. Horn

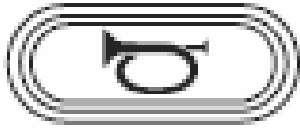

The horn will sound while this button is depressed.

4.2.8. Locking/ unlocking the wheelchair

The R-net control system can be locked to prevent unauthorized use. The locking method is via a sequence of key presses and joystick movements, as detailed below:

To lock the wheelchair:

- While the control system is switched on, depress and hold the on/off button.
- After 1 second the control will beep. Now release the on/off button.
- Deflect the joystick forwards until the control system beeps.
- Deflect the joystick in reverse until the control system beeps.
- Release the joystick, there will be a long beep.
- The wheelchair is now locked.

To unlock the wheelchair:

- Use the on/off button to switch the control system on (a lock is showed on the display).
- Deflect the joystick forwards until the control system beeps.
- Deflect the joystick in reverse until the control system beeps.
- Release the joystick, there will be a long beep.
- The wheelchair is now unlocked.

5. Electromagnetic interference (EMI)

Important: You must be aware of the effect of electromagnetic interference (EMI) regarding your LEVO C³. Please study the following facts carefully.

Electromagnetical interference of transmitter and radio wavelength

Powered wheelchairs might be influenced by strong electromagnetic interference. This interference is caused by radio and tv stations, amateur radio sets (walkie-talkie), two-way radios and mobile phones. Interference (especially of radio stations) might have an influence on the brakes of a powered wheelchair so that they get released and so the chair runs away. It could also happen that the wheelchair starts driving in a not desired direction or the stand-up function could operate non-requested. There could occur constant damages to the steering system of the powered wheelchair.

The intensity of power is measured in volt per meter (vpm). All powered wheelchairs are able to resist to a certain amount of electromagnetic interference. This is called "level of disruptive strength". The security depends on the level of disruptive strength; the higher the level the better the protection. Thanks to modern technology the capability of disruptive strength is up to 20 vpm.

The **LEVO C³** standard version (no further measures) is supplied with a disruptive strength level of 20 vpm.

The **LEVO C³** is constructed to resist to a regular level of interference as it occurs in a household. Beside that there exist a certain number of sources of relatively strong magnetic fields to which you should stay in a safe distance. Some of these magnetic fields are obvious and easy to avoid. Some other are not easy to be realized and it is hard to stay off at times. Please take knowledge of the following list of sources of interference and avoid getting close to these disruptive factors. The EMI-risk is reduced to the minimum when you follow these instructions.

The sources of radiated EMI are put in three categories:

- Portable sender and receiver on which an aerial is directly mounted. Examples: CB-radio, walkie-talkie, sender and receiver of alarming systems, fire alarm, police radio equipment, mobile phone and various private communication systems.
Please notice: Some mobile phones and similar objects transmit signals as soon as they are switched on even if they are not in use at the moment! There have not been any known incidents caused by mobile phones to date.
- Mobile sender and receiver of intermediate range, as they are installed in police cars, fire engines, ambulances and cubs. The aerial is normally fixed on the outside of the vehicle.
- Sender and receiver of a huge range, as radio and TV stations and amateur radio sets.

Be aware that wireless phones, lap tops, AM/FM-radios, TVs, CD players, recorders as well as gadgets like razors, hair dryers and so on are only small

sources of electromagnetic interference. These objects don't cause any problems regarding the functionality of the **LEVO C³**.

Electromagnetical interference in regard to a powered wheelchair

Considering that electromagnetic power reaches high intensity in just a short time as soon as you get close to the source, it is advised to take especially care carrying a sender and receiver with you. It might occur that an item as mentioned gets very close to the controller of the wheelchair and like that electromagnetic energy gets unintended too close too. In this situation the electromagnetic energy might influence negatively the function of brakes as well as the motion characteristics of the wheelchair.

Warning: Your wheelchair can produce electromagnetic emissions as well and disturb other devices.

If unintended movement or brake release occurs, turn the wheelchair OFF as soon as it is safe.

6. Driving the wheelchair

6.1. Driving in general

Before starting to drive your wheelchair take time to read all the instructions regarding the **LEVO C³** and to get to know the controls. When first learning to drive your wheelchair, practice in an area you know well. We suggest a large flat smooth area such as your living room or the driveway to your home. Do not attempt to drive the wheelchair in confined areas or where there is traffic until you are sure you can control the wheelchair safely.

Please note, that the knee support and the chest belt is correctly mounted like 7.1. and 9.9. respectively 7.2..

When driving outdoors always have the seat plate in a horizontal position or tilted backwards (in case seat angle tilt is an optional function).

Switch on the joystick module and practice driving the wheelchair slowly forwards, backwards and turning side to side. When you have more confidence increase the speed and practice until you have mastered driving the wheelchair.

It is possible to drive the wheelchair in the standing position. Speeds are cut to half the speed as soon as the seat leaves the lowest seat position. When indoors practice standing up in the wheelchair and slowly driving it across the room.

The wheelchair allows driving absolutely safely in a sitting position on slopes with a maximum gradient up to 10 degree. When driving up or down steeper slopes than this or over uneven ground, braking and steering response will be limited due to reduced traction. On a slope don't lean out of the wheelchair down the slope. Driving in a standing is no problem on an even and none angled ground.

A limit switch with some important security features programmed is a standard of the **LEVO C³**. In correlation of the current position of the chair and the inclination of the ground the speed is automatically reduced. In extreme situations the system prohibits to continuing driving for the safety of the user. It is be possible to go on as soon as the seat plate is lowered. Please read the detailed information below.

6.2. Obstacles

Avoid driving your **LEVO C³** over obstacles that are higher than 80 mm. The risk to tilt over raises during you drive over high curbs as well as the risk to damage your wheelchair.

If you like to pass an obstacle you never drove over before, **LEVO** recommends doing this with an assistant, to get used to the reactions of the wheelchair.

Because of the special drive mechanism, obstacles can be overcome in an angle of 45°.

Drive carefully if you pass an obstacle.

6.3. Permissible inclinations

The test (TUV, Germany) of the stability of the **LEVO C³** while not in motion proved the following results:

Sitting position facing downhill	13 degree
Standing position facing downhill	10 degree
Sitting position facing uphill (front wheels not touching the ground at the max., but still 100% of stability)	18 degree
Sitting position crossways direction	16 degree
Sitting position 45° to the horizontal direction	9 degree

6.4. Unlock the drive brakes

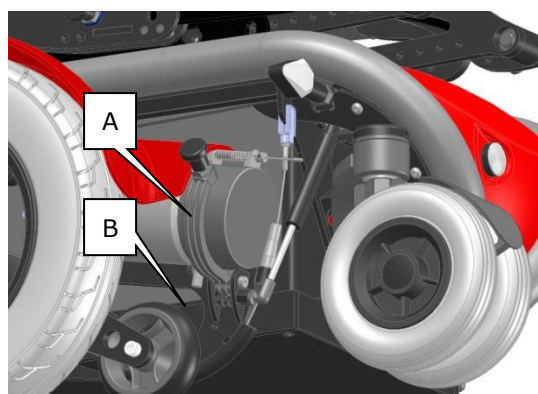

To disengage the motor brakes, to push the chair manually, switch off the control, pull the quick release knob (A) and press the lever (B) down respectively the lever from ON to OFF

Attention: The brakes are out of order in this position.

To bring the wheelchair in the standard driving mode, press the lever (B) upwards respectively from OFF to ON and take care that the quick release knob (A) snaps in.

(new break release from June 2011)

6.5. Charging the batteries

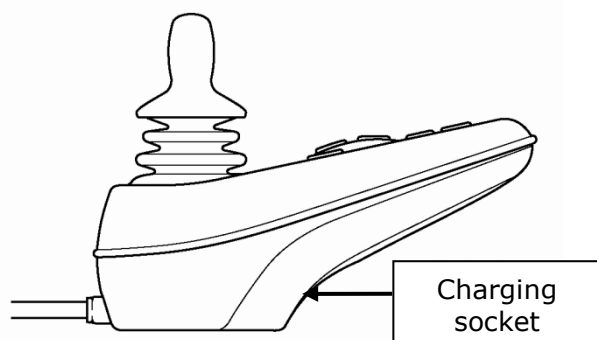

Only use the charger LEVO delivered with the chair.

To charge the batteries, switch off the control unit and plug the charger into the socket beneath the front of the joystick.

If the joystick is witted on, the batteries won't charge.

If the batteries are completely discharged, it takes at least 10 hours to fully charge them.

We recommend to load batteries every night up to the next morning.

7. Safety harness

The safety harness consists of two parts: a chest strap and a knee support.

Caution: Before attempting to stand in your wheelchair, fit and adjust the chest strap and the knee support.

7.1. Knee support

The knee support helps your knee not to bow in the standing position; you are standing with your legs totally stretched. Beside that the knee support keeps you in the perfect position during the stand-up motion.

7.1.1. Knee support „Pro“

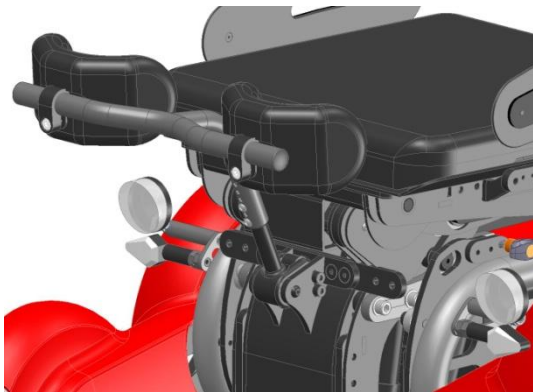

You can insert the knee support with just one hand.
To remove the knee support, pull it a bit to the back and then upwards.
If the adjustments don't fulfill your requirements, please see chapter 8.7.1. to adjust the knee support.
Adjustable knee pads are available.

7.1.2. Knee support „Integral“

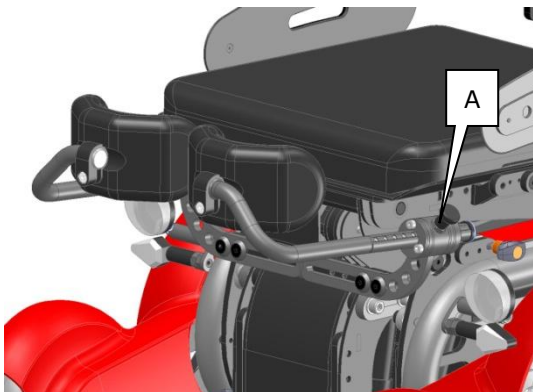

To use the knee support, make sure that it's adjusted correctly.
Pull the quick release knob (A) and bring the knee support in position, release the quick release knob and make sure that it's locked in place.
If the adjustments don't fulfill your requirements, please see chapter 8.7.2. to adjust the knee support.
Adjustable knee pads are available.



There is also a park position which provides to stay the knee support Integral in place by any transfer.

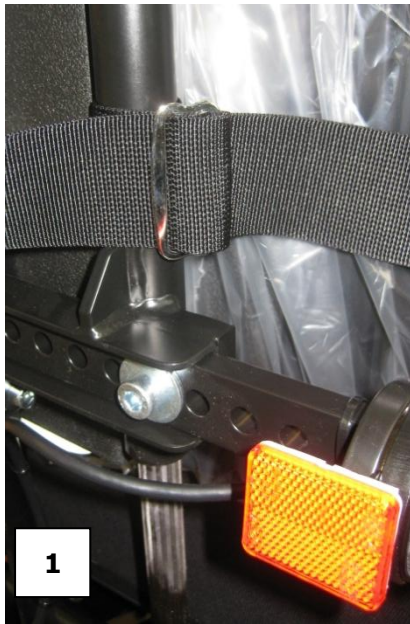

The chest strap has to be round the backrest tubes. The height of the chest strap may be changed.



Guide the chest strap around the backrest posts to the front and secure your torso by closing the buckle (picture 2). Adjust the length of the strap so that it is not too tight but fits comfortably across your chest.

The length can be adjusted in two different ways.



There is a closure at the buckle for small adjustments of the length (picture 3).

If you need to adjust the length of the chest strap more, you have to do it at the back of the chest strap.

Take off the chest strap and change the length at the two metal-buckles (picture 4).



8. Transfer

8.1. Getting into the wheelchair

- Make sure the wheelchair joystick module is switched off.
- Check if the motor disengaging lever is in the ON position for no movements of the powered wheels.
- Lift up the footplates.
- Transfer yourself onto the seat using the armrests for support or have yourself transferred onto the seat.
- Lock the footrests down and rest your feet on them.
- Fit the knee support and chest strap.

8.2. Getting out of the wheelchair

- Make sure the wheelchair joystick module is switched off.
- Check if the motor disengaging lever is in the ON position for no movements of the powered wheels.
- Remove the chest strap and knee support.
- Lift up the foot plates.
- Transfer yourself in your usual way out of the wheelchair or have yourself transferred out of the wheelchair.

8.3. Sideways transfer

- Drive as close as possible to a chair, bed or any other objects you want to transfer to.
- Make sure the joystick module is switched off.
- Check if the motor disengaging lever is in the ON position for no movements of the powered wheels.
- Flip up the footrest of the wheelchair and put your feet on the ground.
- Lift up the armrest on the side you are transferring to.
- Transfer yourself in your usual way out of the wheelchair or have yourself transferred out of the wheelchair.

9. Individual settings

The **LEVO C³** is individual adjustable to every person. Partly it is necessary to have tools for the adjustments; on some elements it is possible to adjust them simply without any tools.

Required tools:

- Allen key: from 3mm to 8 mm
- Spanner: 13 mm

9.1. Adjustment of the seat depth

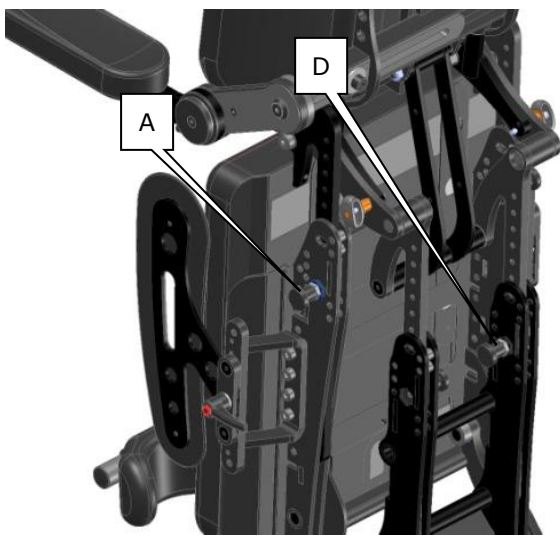

The seat depth will be adjusted with (optional w/o) tools. Adjust the lower levers first. Release the screw (pull the bolt) (C) and (D). Now you can set the levers to the necessary length. Tighten the screw (release the bolt) and lock the lever in the new position.

Now you can adjust the upper levers. Release the screw (pull the bolt) (A) and (B). Now you can adjust the lever to the **same number/length** like the lower levers. Tighten the screw (release the bolt) and lock the lever in the new position.

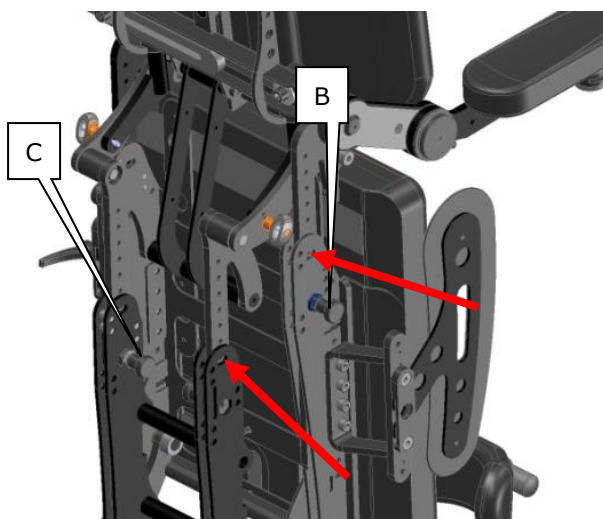

Please watch the red arrow on the picture.

Warning: Please watch the right position of the lower and the upper lever. Per example, if you choose the seat depth of 48cm, 48cm have to be shown at the small window (red arrow at the picture left).

9.2. Change of the seat width

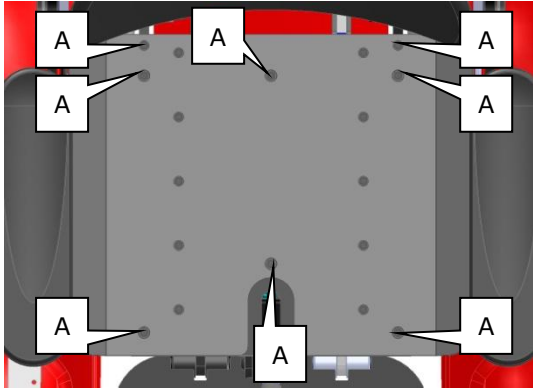

Take off the seat cushion first.
Telescope the seat plate to the first position (see chapter 9.1.)

Untighten the 8 screws (A) at the seat plate, to be able to take off the whole seat plate.

Put the new wider/smaller seat plate on the chair and tighten the 8 screws to fix the new seat plate.

The adjust the distance between the armrests to the seat plate, follow the instructions in chapter 9.3.

To adjust the knee support to the changed seat width, follow the instructions in chapter 9.7.

If the chair is equipped with the skirt guard, you have to change the bracket, to match it with the seat width.

9.3. Change the distance between the armrests



Untighten the two screws. Now you can adjust the armrests in the width.

If you have adjusted them to the desired width, tighten the screws.

9.4. Adjustment of the backrest angle

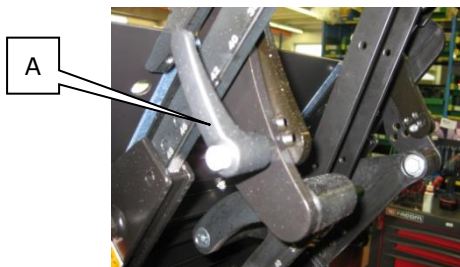

You can adjust the backrest in different angles.

Unscrew the lever-screw (A) on both sides. Now you can tilt the backrest back and forward to the desired angle. Put the lever-screw (A) into the hole where the backrest post and the plate correspond.

9.5. Change of the distance footrest - seat cushion and angle adjustment of the footrest

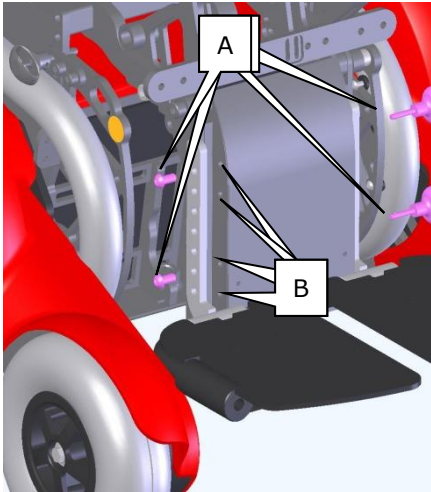

The footrest will be adjusted with (optional w/o) tools.

To change the height of the footrest, release the screw (A). Now you can set the footrest to the necessary height.

Tighten the screw back in place.

On both sides there are 4 holes (B) you can use to adjust the height.

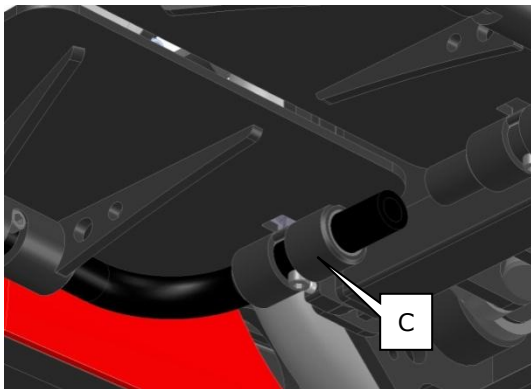

The angle of the footrest plate is adjustable by turning on the screw (C).

If you turn the screw clockwise, the plate is rising, if you turn the screw counter clockwise, the plate is lowering.

That the screw isn't becoming unscrewed, we recommend mounting the screw with thread locker.

9.6. Adjustment of the armrest height/angle

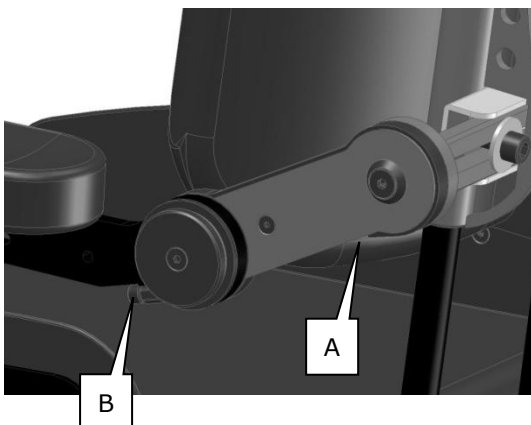

To adjust the height respectively the angle, please refer as follows:

Height adjustment

To lower the armrest unscrew screw A. To increase the height tighten the screw A.

Angle adjustment

To lower the angle unscrew screw B. To increase the angle tighten screw B.

9.7. Adjustment of the armrest length



You can adjust the position of the armrest pad. Just unscrew the two screws (A) a bit and then you're able to shift the pad forward and backwards. After you reached the necessary position, tighten the screws (A) until the pad is fixed.

9.8. Change the position of the control unit

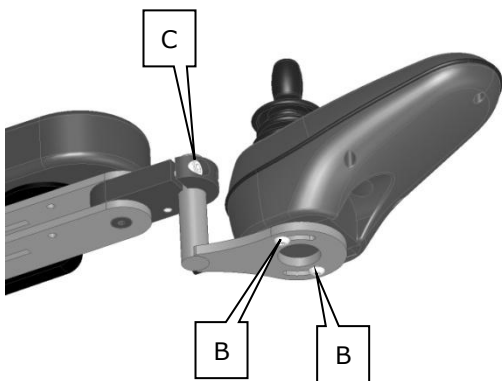

You can adjust the control unit to the inner or outer side.

Untighten the screws (B) and screw (C), now you can bring the control unit into the necessary position. If you have reached the correct position, tighten the screws.

9.9. Adjustment of the knee support

9.9.1. Knee support „Pro“

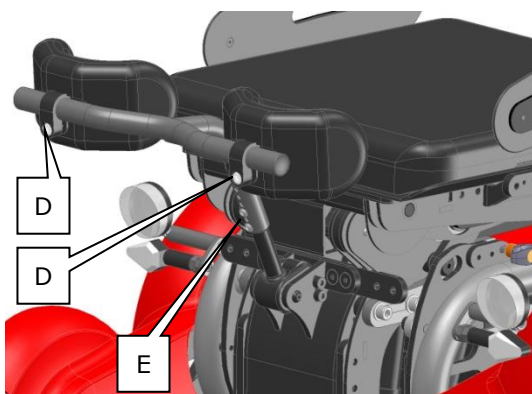

Adjusting the distance between the knee pads:

Untighten the two screws (D), adjust the knee pads to the necessary width and tighten the screws (D).

Adjusting the height of the knee support:

Untighten the two screws (E), now you can adjust the height of the knee support. If it is adjusted to the correct position, put the screws (E) back into place and tighten them. Adjustable knee pads are available.

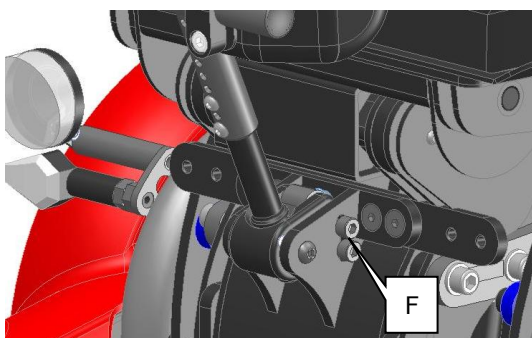

Adjustment of the angle:

Untighten the 4 screws (F), now you can adjust the angle of the knee support. If the correct position is reached, tighten the screws.

9.9.2. Knee support „Integral“

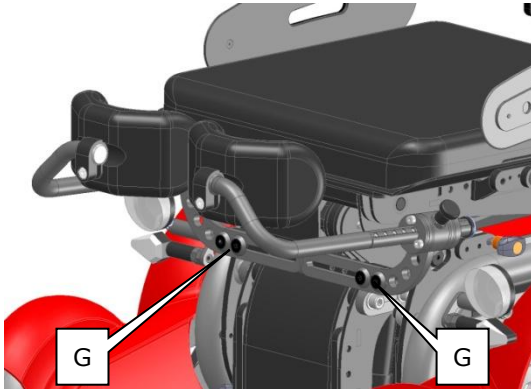

Adjusting the distance between the knee pads:

Untighten the 4 screws (G), adjust the knee support to the necessary width and tighten the screws (G). Height adjustable knee pads are available.

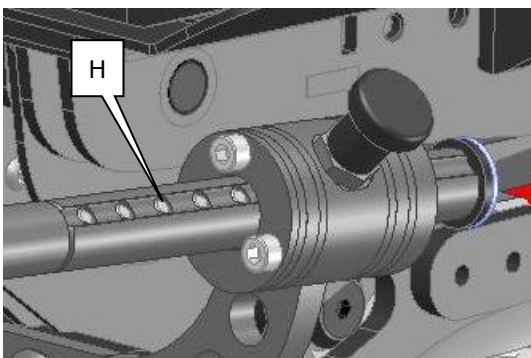

Adjusting the depth of the knee support:

Check in which hole, the quick release bolt has to lock, turn the set screw (H) counterclockwise downwards, that the quick release bolt can lock into the hole.

Check the hole that was used before, turn this set screw clockwise that the hole is blocked.

9.10. Adjustment of the backrest height

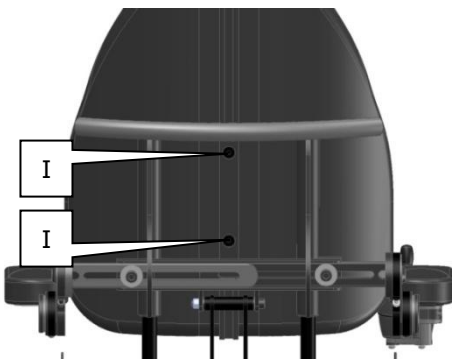

You can adjust the height of the backrest by untighten the two screws (I) a bit. Then you're able to shift the backrest up and down. If the backrest is in the desired position, tighten the screws (I).

Please check the adjustment in standing position. The back must have space to the seat cushion respectively the back must not touch the seat plate in standing position.

10. Options

The **LEVO C³** can be equipped with several options. The most options can also be mounted after the chair is delivered.

10.1. Tilt in space



With the option „Tilt in space“ it’s possible to tilt the seat to an angle of approx. 30° to the back, this leads to a more comfortable seat-/ rest-position. The “Tilt in space” is a good prevention against decubitus by the way.

In chapter 4.6. you can see how the “Tilt in space” can be adjusted.

10.2. Swing away holder for the Control unit

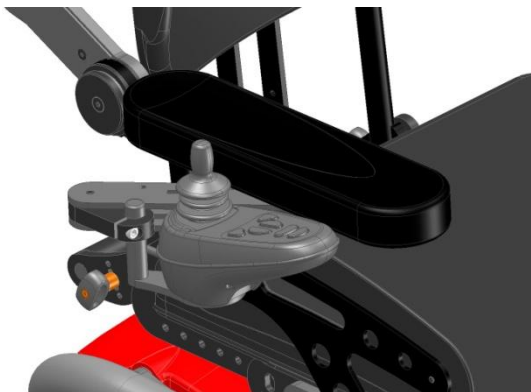

The swing away joystick holder is used to drive closer to a table for example. The transfer can also be easier, if the control unit is retractable.

With the aid of the magnet that’s mounted at the armrest, you can adjust the force, that’s needed to deviate the control unit.

10.3. Joystick protection guard

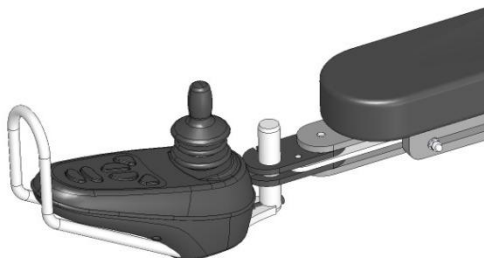

You can avoid collisions between the joystick and other objects with the joystick protection guard.

It protects the users hand on the joystick as well.

10.4. Swing away table tray

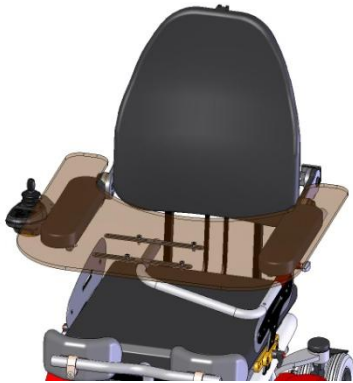

The swing away table tray is retractable to the side, if you don't need it.

10.5. Skirt guard

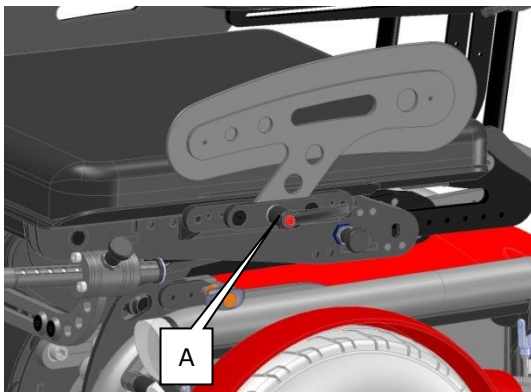

The skirt guard should prevent that the clothing is hanging beside the seat and is getting into the drive wheels or the standing mechanism. The skirt guard is easily displaceable for lateral transfers. Just untighten the stop lever (A), now you can easily lift the skirt guard upwards to remove it.

10.6. Upper leg support



Leads the thigh and stabilizes the leg axle in seating and standing position. Can be adapted individually in place, distance, angle and height. To change the position, open the zipper at the outside of the pad and untighten the screws lightly, now you can adjust the pad to the necessary position, tighten the screws afterwards.

10.7. Chest role



The chest role gives a feeling of more safety and stability, especially while standing.

Important: It does not replaces the chest strap.

It is individually adjustable in the height.

10.8. Foot guide

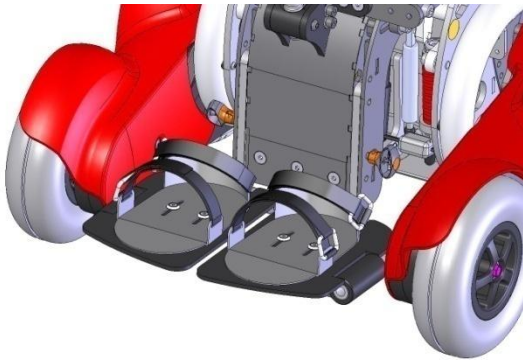

The foot guides give a better opportunity to place and stabilize the feet.

They are individually adjustable, you just have to drill two holes into the footplate at the necessary place, to mount the foot guides with the provided screws.

10.9. Lamps for outdoor use with indicators

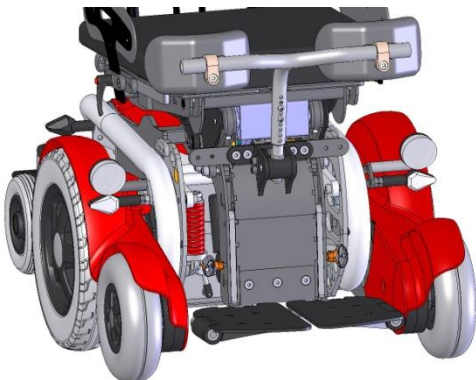

Some countries assume a fully functional light kit, to drive on public roads with the chair.

LEVO AG recommends to equip the chair with light, if you use your **LEVO C³** predominant outdoors.

If you wish to equip your chair afterwards with the light kit, your **LEVO-Dealer** /-distributor can mount it additionally.

10.10. Jostick-top



If you are not satisfied with the standard joystick knob, there are several different shapes available. To change it, just pull the knob upwards to remove it and push the new knob over the joystick post.

10.11. Rear view mirror

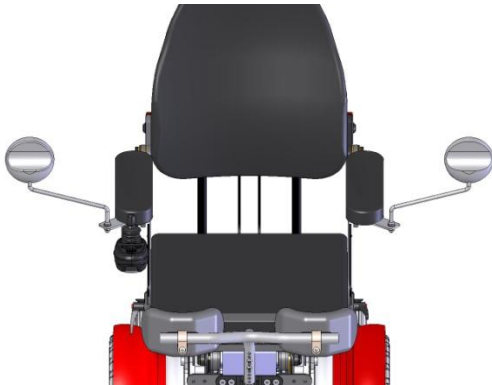

To have a better overview in the public traffic, you can have rear view mirrors on your **LEVO C³** as well.

11. Transportation of your wheelchair

To have a bit smaller dimensions of the chair, when you like to transport it, there are two things you can do:

- Flip up the footrest
- Fold down the backrest (take off the quick pin and fold it)

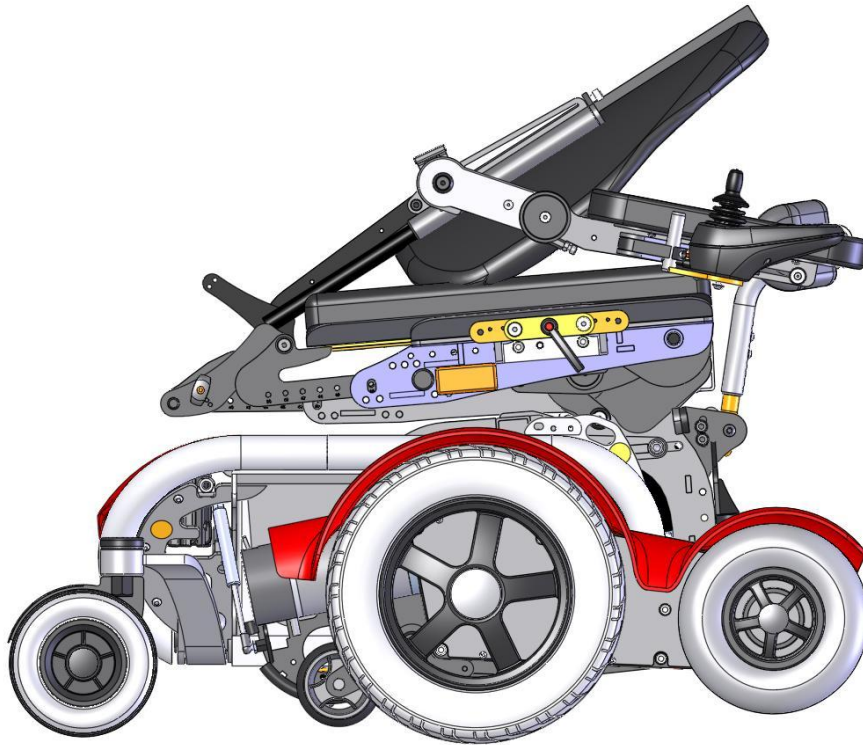

11.1. Transportation in a vehicle without the person in the wheelchair

When transporting the wheelchair in a motor vehicle, make sure that the wheelchair is so secured as to prevent it sliding about or tipping over. Just use the licensed fastening systems and secure the wheelchair at the marked anchorage points (hook sticker).



Here's an example how the chair should be strapped down in a motor vehicle:

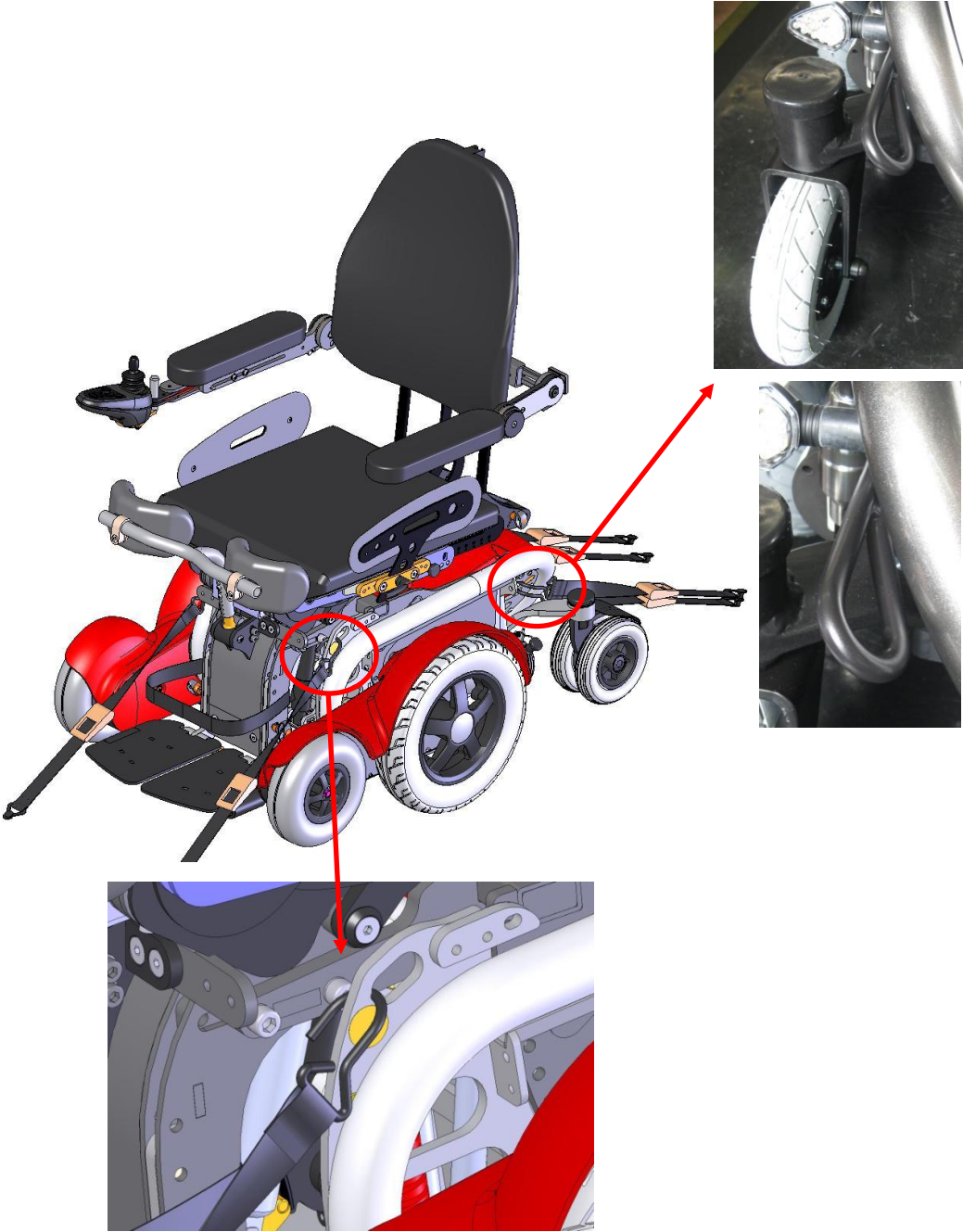

11.2. Transportation in a vehicle with the person in the wheelchair

The **LEVO C³** passed the crash test after the norms ISO 7176/19 and ANSI/RESNA WC/Vol. 1-Section 19.

The **LEVO C³** has been positively crash tested for car transportation after the norms mentioned above. Please read the information/instructions below:

Certified test centre:	Millbrook Proving Ground Ltd, Bedford MK45 2JQ, UK
Millbrook Report No.:	MBK 07/0995
Millbrook Test No.:	S10169
Restraints Wheelchair:	Q'Straint 4 Punkte Gurten mit Karabiner (http://www.qstraint.com/english/products/products.aspx)
Restraints Occupant:	Q'Straint Vehicle Anch 3-Pt
Requirements ISO 7176/19:	Pass
And ANSI/RESNA Section 19:	Pass

Preparations of the **LEVO C³** before using it for car transportation:

1. The chair has to be tight down by using the Q'Straint 4 pt with karabiners or any restraint system that has been tested and passed the ISO 10542/2 standards.
2. The occupant has to be safely secured by using the Q'Straint Vehicle Anch 3-Pt or any restraint system that has been tested and passed the ISO 10542/2 standards.

12. Cleaning

- Whenever the wheelchair gets dirty it should be cleaned using a damp cloth and then dried thoroughly.
- For more stubborn stains wipe with a damp cloth using a mild solution of warm water and a mild cleansing agent.
- Never use furniture polish, spirit or solvents to clean the frame.
- In case of dirt on the seat cushion cover or the back rest cover, you can remove both of it and wash it softly. Do not wash it warmer than **40 degree Celsius or according the cleaning instructions on the label inside the cushion cover.**

Caution: Never use high pressure water cleaner.

13. Maintenance

13.1. Service

The **LEVO C³** is designed to be maintenance free and apart from the items below does not require attention from the user.

Please note that to maintain safe and efficient operation the wheelchair should be serviced at least once per year by your LEVO agent or authorized dealer. This annual service has to be filled into the service card from the agent/dealer.

The user or their family can easily carry out the following tasks.

- Keep the wheelchair clean.
- Never store the wheelchair when damp.
- Keep the batteries charged to the maximum.
- Check if all fittings, harness, etc. are working properly (see section 6. - 8.).
- Check operation of motor disengaging lever weekly.
- Check operation of all controls daily.
- If any faults are found, report them immediately to your agent. He will advise you whether to continue using the wheelchair or not, and what action you should take to repair the wheelchair.

13.2. Safety checks

The electronic circuits in your control system have been designed to be extremely safe and reliable. The on-board microcomputer carries out safety checks at up to 100 times per second. To supplement this safety monitoring you should carry out the following periodic checks.

If the control system fails any of these checks, do not use the wheelchair and contact your service agent.

13.2.1. Daily checks

Joystick: With the control system switched off, check that the joystick is not bent or damaged and that it returns to the center when you push and release it. If there is a problem do not continue with the safety checks and contact your service agent.

13.2.2. Weekly checks

Solenoid (parking) brake:

This test should be carried out on a level floor with at least one meter clear space around the wheelchair.

- Switch on the control system.
- Check that the battery gauge remains on, or flashes slowly, after one second.
- Push the joystick slowly forwards until you hear the parking brakes operate.
The chair may start to move.
- Immediately release the joystick. You must be able to hear each parking brake operate within a few seconds.
- Repeat the test a further three times, pushing the joystick slowly backwards, left and right.

Connectors:	Make sure that all connectors are securely mated.
Cables:	Check and ensure that the condition of all cables and connectors are OK and without damage.
Joystick gaiter:	Check the thin rubber gaiter or boot, around the base of the joystick shaft, for damaged or splitting. Check visually only, do not handle the gaiter.
Mounting:	Make sure that all the components of the control system are securely mounted. Do not over tighten any securing screws.

13.3. Spare parts

LEVO AG delivers single parts or modules as spare parts. Your distributor can provide all spare parts listed for your **LEVO C³**. You have also the opportunity to order a spare part list from **LEVO AG** directly.

14. Disposal

Wheelchair:

Return the wheelchair after the product lifetime to the sales point. The dealer will dispose of it according to local regulations. Regarding the possibilities for individual adjustments your **LEVO C³** might be of use to another stand-up wheelchair user.

Batteries:

Return old batteries to the sales point of the wheelchair or of the new batteries. The dealer will dispose of them according to local regulations. Remove the batteries especially careful, if they could have a damaged casing, because there is the risk of a chemical burn.

15. Trouble shooting

If you have problems with your wheelchair check this list before calling your local agent.

ITEM	PROBLEM	Solution
Joystick Module	Battery level indicator does not light	<ul style="list-style-type: none"> • Switch on ON/OFF switch • Insert fuse / switch on safety cut out • Unplug charging plug • Replace battery • If above does not work consult LEVO agent
	Battery level indicator flashes slowly	<ul style="list-style-type: none"> • Charge Battery
	Battery level indicator blinks every 2.5 Seconds	<ul style="list-style-type: none"> • Joystick module in sleep mode. To restart switch off then on again
	Battery level indicator flashes rapidly	<ul style="list-style-type: none"> • See chapter 16
Driving	Will not drive in a straight line	<ul style="list-style-type: none"> • Consult LEVO agent
	Motors turn and battery level indicator lights up but chair does not drive	<ul style="list-style-type: none"> • Push motor disengaging lever upwards • Charge batteries
Battery charger 2412SRF	LED 1 does not light	<ul style="list-style-type: none"> • Plug in main plug • Check fuse at the charger • Check household fuse
	LED 1 lights red, but LED 2 does not light	<ul style="list-style-type: none"> • Check fuse at the charger • Consult LEVO agent
	LED 1 lights, LED 2 flashes green	<ul style="list-style-type: none"> • Check charging plug is inserted • Check safety switch is on • Consult LEVO agent
	LED 1 lights, LED 2 flashes fast green	<ul style="list-style-type: none"> • Charger has a damage • Check with your dealer to replace the charger
	Red Polarity lamp LED 2 lights	<ul style="list-style-type: none"> • Unplug charger immediately • Consult LEVO agent

16. Controller self help guide VR2

The battery indicator provides information in case a fault occurs to the wheelchair's electrical system. An appropriate number of lights flash rapidly on the display for a particular fault. Please see below.

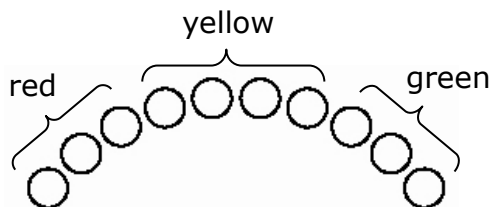

Lights flashing		
10 green	High battery voltage	An excessive voltage has been applied to the control system. This is usually caused by a poor battery connection. Check battery and power module connections. If the fault remains contact your local agent.
9 green	Solenoid brake fault	The parking brakes have a bad connection. Make sure all connectors are plugged in properly. If the fault remains contact your local agent
8 green	Possible power module fault	A Power Module fault is indicated. Make sure all the power module connections are pushed in properly.
7 yellow	Possible joystick module fault	A joystick fault is indicated. Make sure the joystick is in the rest position before switching on.
6 yellow	Charger connected	The battery charger is plugged into the wheelchair. Unplug the charger from the joystick module.
5 yellow	Right motor wiring fault	The right-hand motor has a short circuit to a battery connection. Contact your local agent.
4 yellow	Right motor disconnected	The right-hand motor has a bad connection. Make sure the motor connector is plugged in properly.
3 red	Left motor wiring fault	The left-hand motor has a short circuit to a battery connection. Contact your local agent.
2 red	Left motor disconnected	The left-hand motor has a bad connection. Make sure the motor connector is plugged in properly.
1 red	Low battery voltage	The battery needs charging or there is a bad connection in the battery. Check connections to the battery, power module and joystick module.

Please contact your local specialist in case you followed the advices but the problem still exists. Please provide your specialist with the serial number of your **LEVO C³** which is noted on the warranty card. This number might be important in case of questions to the manufacture company **LEVO AG**.

17. Controller self help guide R-net

The joystick module has its own error-management-system. If an error occurs, a message is indicated on the display, for example this could look like that:

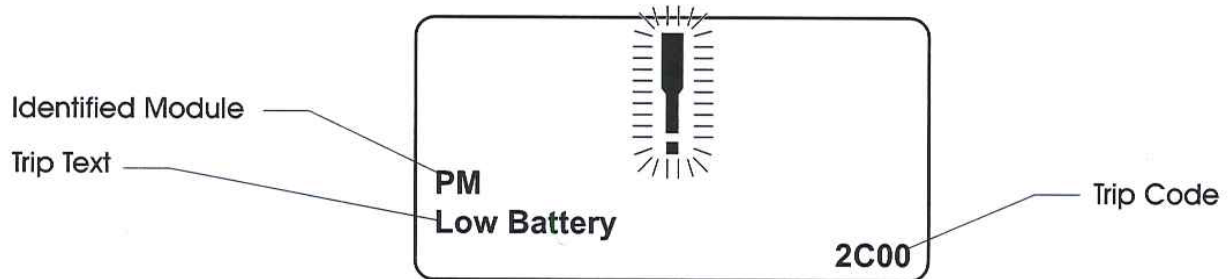

If you can't solve the problem, just with the showed message, you can enter the trip code on the PG Drives homepage (<http://www.pgdt.com/diagmob/diagnostic.asp>), there you'll get some more information about the error and how you can solve it. If you can't solve the problem, please get in touch with your **LEVO**-dealer.

18. Technical information

Model	LEVO C³			
Wheelchair category	B			
Seat width	32 – 52 cm			
Overall width	63 cm			
Overall length (without footplate)	105 cm			
Overall length (with footplate)	105 cm			
Overall height, incl. backrest	100 cm			
Backrest	V-Trak 40cm (or any other optional heights)			
Seat height (incl. Seat cushion)	48 cm			
Seat depth	38 – 66 cm			
Type of tire	breakdown safe, without air			
Size of tire	front 2.80/2.50-4"	middle 3.00-8"	back 7x1 3/4"	
Footrest	height and angle adjustable			
Max. weight	185 kg			
Max. total load	140 kg			
Speed	0-10 km/h			
Turning circle	110 cm			
Max. gradient (sitting position)	10°			
Max. gradient (standing position)	3°			
Curb climbing ability (sitting position)	8 cm			
Curb climbing ability (standing position)	2 cm			
Range (55 Ah/ 73 Ah batteries)	25 km/ 35 km			
Battery charger	Brand: MK LS24/8 E DUAL voltage 24V DC, current 8A			
Joystick module	PG Drives VR2 90A or R-net 120A			
Programming of driving characteristics	Standard for trained	Classic for newcomer	Fun for experts	
Colour	Standard: RAL-colours yellow / red / blue / black	Optional: Metallic red / green / blue / silver	Optional: 184 other colours of the RAL-offer	Optional: 3 reflex colours orange/ lemon / silver

Description	Battery 48 Ah	Battery 73 Ah
Voltage	12 V	12 V
Capacity	48 Ah	73 Ah
Dimensions in cm (L x W x H)	23x14x20.5	26x17x20.5
Quantity built in chair	2	2

19. Version-Management

Version-No.	Date	Description	Author
1.0	10.07.08	First released version	T. Meier
1.1	19.11.08	Additions for aid numbers	T. Meier
1.2	09.12.08	Additions for Handicap Institute	T. Meier
1.3	05.02.09	Miscellaneous changes in chapters	T. Meier
1.4	24.02.09	Additions for the R-net control system	T. Meier
1.5	01.01.10	Miscellaneous changes in chapters	T. Räber
1.6	23.07.10	Additional in safety instructions	H. Bögli
1.7	01.04.11	New main fuse version	H. Bögli
1.8	12.04.12	Improvements	H. Bögli