



**DISHWASHERS
WITH PULL-THROUGH RACK**

M115

**INSTRUCTIONS
MANUAL**



CE

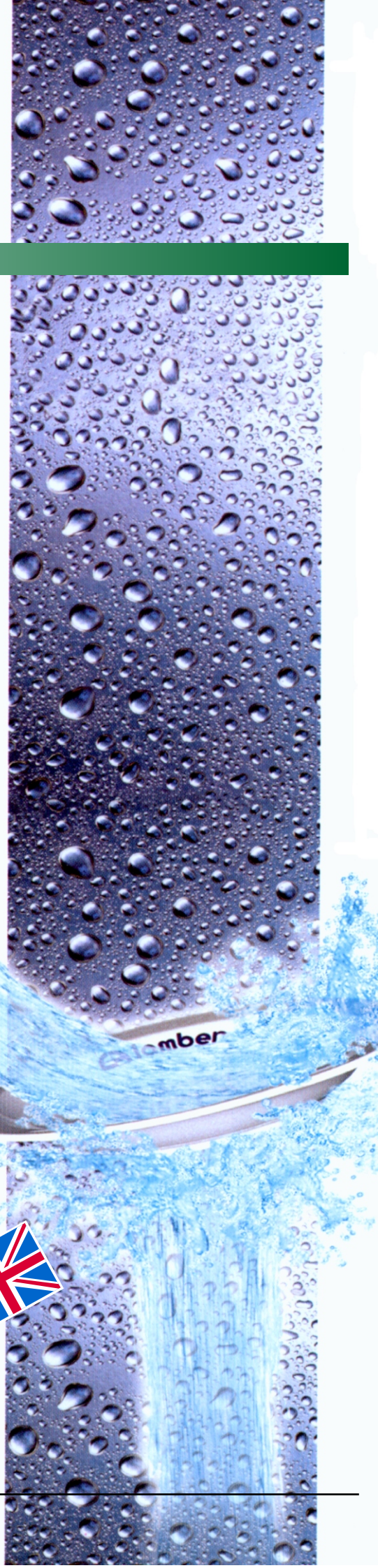

**DICHIARAZIONE DI CONFORMITA' - DECLARATION OF CONFORMITY
DECLARATION DE CONFORMITE' - KONFORMITÄTS ERKLÄRUNG**

Noi - The following - Nous soussignés - Die Unterzeichnete Fa:

LAMBER snc di Affaba F e C.

Via Italia 6

26855 Lodivecchio (LO) ITALY



dichiariamo sotto la nostra esclusiva responsabilità che il prodotto
hereby declares under full responsibility that the following product
attestons sous notre entière responsabilité que le produit suivant
erklärt unter eigener Verantwortung, dass folgende Produkte

LAVASTOVIGLIE A TRAINO - LAVE-VAISSELLE A' AVANCEMENT AUTOMATIQUE DE CASIERS -
RACK CONVEYOR DISHWASHERS - KORBTRANSPORTAUTOMATEN

mod. **M115**

al quale questa dichiarazione si riferisce è conforme alle seguenti norme:
for which this declaration refers to the conformity of the following standards:
auquel se réfère cette déclaration, est conforme aux normes suivantes:
auf welche sich diese Erklärung bezieht, folgendem Standard entsprechen:

- **EN 60335-1 (1994) + A11,A12,A13,A14,A15**
Sicurezza degli apparecchi elettrici d'uso domestico e similare. Norme generali
Safety of household and similar electrical appliances-General requirements.
- **EN 60335-2-58 (1997)**
Sicurezza degli apparecchi elettrici d'uso domestico e similare. Parte 2':Norme particolare lavastoviglie uso
collettivo.
Safety of household and similar electrical appliances-Part 2':Particular requirements for commercial electric
dishwashing machines.
- **EN 292-2 (1992) Part 1' - PART 2'**
Sicurezza del macchinario-Concetti fondamentali-Principi generali progettazione-Specifiche e principi tecnici.
Safety of machinery-Basic concepts-General principles for design-Technical principles an specification
- **EN 61770- (2000)**
Apparecchi elettrici connessi alla rete idrica. Disposizioni per evitare il ritorno d'acqua per effetto sifone e il
guasto dei complessi di raccordo
Electric appliances connected to the water mains. Avoidance of backsiphonage and failure of hose-sets

in base a quanto previsto dalle Direttive:
selon ce qui est prévu par les Directives:
on the basis of what is foreseen by the Directives:
aufgrund der vorgesehenen Richtlinien:

73/23/CEE, 89/392/CEE, 91/368CEE,92/31CEE, 93/44CEE, 93/68CEE

Decliniamo ogni responsabilità per sinistri a persone o a cose derivanti da manomissioni da parte di terzi o da carenze di manutenzione o riparazione.
Nous déclinons toute responsabilité pour sinistres à personnes ou à objets qui dérivent de l'intervention de la part de tiers non spécialistes ou de
carences de manutention ou réparation.
We decline any responsibility for injuries or damage derived from machine misuse, abuse by others or improper machine maintenance or repairs.
Wir lehnen jegliche Verantwortung für Schäden an Personen oder Dingen ab, die auf fehlerhaftes Eingreifen Dritter oder auf mangelhafte Wartung oder
Reparation zurückzuführen.

li 01/01/06

(data/date/Datum)

Ing. Affaba Roberto

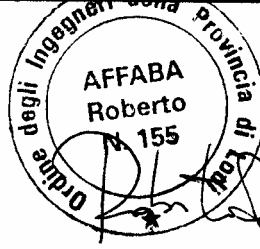

(name signature or equivalent of authorized representative)

- EMC -

Noi - The following - Nous soussignés - Die Unterzeichnete Fa:

LAMBER snc di Affaba F. e c.

Via Italia 6

26855 Lodivecchio (LO) ITALY

dichiariamo sotto la nostra esclusiva responsabilità che i prodotti
hereby declares under our responsibility that the following products
attestons sous notre entière responsabilité que le produit suivant
erklärt unter eigener Verantwortung, dass folgende Produkte

LAVASTOVIGLIE A TRAINO - RACK CONVEYOR DISHWASHERS - LAVE-VAISSELLE A'
AVANCEMENT AUTOMATIQUE DES CASIERS - KORBTRANSPORTAUTOMATEN

mod. **M115**

ai quali questa dichiarazione si riferisce sono conformi alle seguenti norme:

auquel se réfère cette déclaration, est conforme aux normes suivantes:

to which this declaration relates are in the conformity with the following standards:

auf welche sich diese Erklärung bezieht, folgendem Standard entsprechen:

- *Limits and methods of measurement of radio disturbance characteristics of electrical motor-operated and thermal appliances for households and similar purposes, electric tools and similar electric apparatus.*
EN 55014-1 - Edit. 2000 + A1
Limiti e metodi di misura delle caratteristiche di radiodisturbo degli apparecchi elettrodomestici, e similari a motore o termici, degli utensili e degli apparecchi elettrici similari. EN 55014-1 - Ediz. 2000 + A1
- Electromagnetic compatibility (EMC) – Part 3-2: Limits – Limits for harmonic current emissions (equipment input current ≤ 16 A per phase) – EN 61000-3-2 (2000)
Compatibilità elettromagnetica (EMC) – Parte 3-2: Limiti – Limiti per le emissioni di corrente armonica (apparecchiature con corrente di ingresso ≤ 16 A per fase) – EN 61000-3-2 (2000)
- Electromagnetic compatibility (EMC) – Part 3-3: Limits – Limitation of voltage fluctuations and flicker in low-voltage supply systems for equipment with rated current ≤ 16 A – EN 61000-3-3 (1995) + A1 (2001)
Compatibilità elettromagnetica (EMC) – Parte 3-3: Limiti – Limitazione delle fluttuazioni di tensione e dei flicker in sistemi di alimentazione in bassa tensione per apparecchiature con corrente nominale ≤ 16 A – EN 61000-3-3 (1995) + A1 (2001)
Only for current $> 16^\circ$ per phase
- Electromagnetic compatibility (EMC) - Part 3-11: Limits - Limitation of voltage changes, voltage fluctuations and flicker in public low-voltage supply systems – Equipment with rated current ≤ 75 A and subject to conditional connection - EN 61000-3-11 (2000)
Compatibilità elettromagnetica (EMC) – Parte 3-11: Limiti - Limitazione delle variazioni di tensione, fluttuazioni di tensione e dei flicker in sistemi di alimentazione pubblica in bassa tensione. Apparecchiature con corrente nominale ≤ 75 A e soggetti ad installazione condizionata - EN 61000-3-11 (2000)
- *Immunity requirements for household appliances, tools and similar apparatus.*
Product family standard
EN 55014-2 - Edit. 1997 + A1
Requisiti di immunità per apparecchi elettrodomestici, utensili e degli apparecchi elettrici similari.
EN 55014-2 - Ediz. 1997 + A1

in base a quanto previsto dalle Direttive:

following the provisions of the Directives:

selon ce qui est prévu par les Directives:

aufgrund der vorgesehenen Richtlinien:

EC 89/336, EC 92/31 EC 93/68

Ing. Affaba Roberto

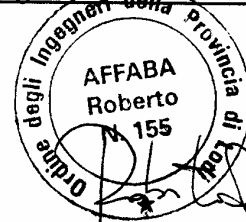

li 01/01/06
(data/date/Datum)

(name signature or equivalent of authorized representative)

MODEL DESCRIPTION

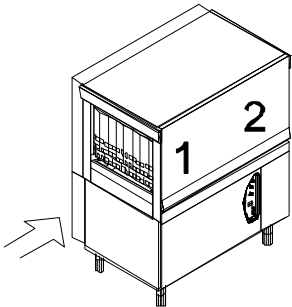
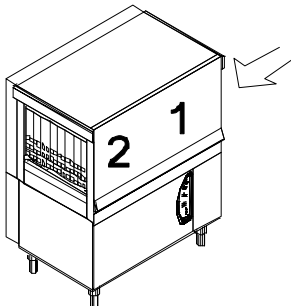
MODEL	MODEL
<input type="checkbox"/> M115 left-right  An isometric line drawing of a rectangular machine with a front-loading door. The door has a handle on the right side. The number '1' is on the left side of the door, and the number '2' is on the right side. An arrow points to the left side of the machine.	<input type="checkbox"/> M115 right-left  An isometric line drawing of a rectangular machine with a front-loading door. The door has a handle on the left side. The number '2' is on the left side of the door, and the number '1' is on the right side. An arrow points to the right side of the machine.

LEGEND

1	WASHING
2	RINSING

HEATING

<input type="checkbox"/>	ELECTRIC
<input type="checkbox"/>	STEAM

TECHNICAL DATA AND DESCRIPTION

The table reported at page 3 shows the basic models of conveyor dishwashers and identifies the single washing areas to which additional modules can be added to improve their performance.

ACCESSORIES

COLD PRE-WASHING						
STEAM CONDENSER - CVM	fan		kW			
DRYING – ASM - MVM	fan		kW	Heat element		kW
ADDITIONAL RINSING - RIS						
AUTOTIMER						
SPLASH SHIELD (PMC-PMA-PMA/R)						
BOOSTER PUMP	Motor		kW			

TECHNICAL SPECIFICATIONS

Model:

version	Left-Right		Right-Left
----------------	-------------------	--	-------------------

1st speed	baskets/hour		2nd speed	baskets/hour
-----------------------------	---------------------	--	-----------------------------	---------------------

ELECTRIC POWER	kW
ELECTRICAL INPUT	A
ELECTRIC CABLE	mm²
CIRCUIT BREAKER	A
Icc ELECTRIC INPUT	6 kA
VOLTAGE	

PRE-WASHING	TANK ELEMENTS		kW	ELECTRIC PUMP		kW
FIRST WASHING	TANK ELEMENTS		kW	ELECTRIC PUMP		kW
SECOND WASHING	TANK ELEMENTS		kW	ELECTRIC PUMP		kW
THIRD WASHING	TANK ELEMENTS		kW	ELECTRIC PUMP		kW
PRE-RINSING	TANK ELEMENTS		kW	ELECTRIC PUMP		kW
RINSING	BOILER ELEMENT		kW			
	BOILER ELEMENT		kW			
	GEARED MOTOR		kW			

DESCRIPTION

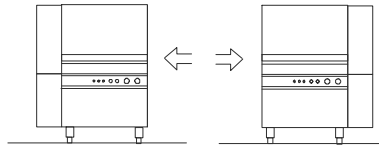

CHARACTERISTICS

- * *Body and tank in stainless steel construction 18/10 AISI 304,*
- * *Tunnel composition:*
 - **1 Wash** - **wash arms : 3 upper + 2 lower**
 - **1 Rinse** - **rinse arms : 1 upper + 1 lower**
- * *Completely automatic,*
- * *Upper and lower fixed washing (60 °C)*
- * *Upper and lower fixed rinsing (85-90 °C)*
- * *Washing and rinsing arms in **stainless steel** constructions, easy disassembly and interchangeable,*
- * ***Double skin** with thermic and acoustic insulation ;*
- * ***Slanted tank with rounded edges,***
- * ***Stainless steel autodrainng washing pump,***
- * ***Counterbalanced door***
- * *Front panel composition ::*
 - *Main ON/OFF switch;*
 - *Start pushbutton*
 - *Stop pushbutton*
 - *Emergency pushbutton*
 - *Machine ON indicator*
 - *Machine ready indicator*
- *Overload cutout indicator*
- * *Frontal maintenance*
- * *Automatic tank loading*
- * *Rinse economizer*
- * *Tank and pump filters*
- * *Insulated Boiler*

SAFETY

- * *Feet adjustable and strong*
- * *Pressure-switch protection for Heating elements*
- * *Thermic protection for washing pump*
- * *Automatic stopping of pull-through in case of foreign bodies*
- * *Low voltage control circuit (24V) for greater safety during work operation*
- * *Dishes (Stop with End Micro-switch on the exit table)*
- * *Door opening safety device*

Contents

General norms	page	07
Introduction and safety norms	page	08
Unpacking and delivery checks	page	10
1 – INSTRUCTIONS FOR THE USER	page	11
<u>First section - For the user – Operation before washing</u>	<u>page</u>	<u>12</u>
Switch-on and use of the dishwashing machine mod. M115	page	14
Switch-on and use of the dishwashing machine mod. M115-ASM	page	15
Washing of dishes – During washing operations	page	18
After washing operations	page	20
Helpful suggestions - Achievements	page	21
Safety devices	page	22
Washing flow control system	page	24
Useful hints of stainless steel maintenance	page	25
2 – INSTRUCTIONS FOR THE INSTALLER	page	26
Installation	page	27
<u>Second section - For the installer - Disposal</u>	<u>page</u>	<u>28</u>
Positioning – Electrical connection	page	30
Water connections	page	31
Water draining - Steam feeding –	page	32
Steam exhaust – Vapours suction – Testing - Working temperatures	page	33
Torque limiter	page	34
Steam condenser	page	35
Modification of parameter's programming	page	36
Possible drawbacks – causes - remedies	page	39
Table connection scheme	page	45
Wiring diagram	page	46

INSTRUCTIONS MANUAL DISHWASHING MACHINE

M115

The automatic-rack conveyor dishwashing machines of the M115 series are designed to wash any kinds of dishes .

The modular system and the various optionals available allow the make-up of dishwashing machines with the most appropriate features in order to meet your production,space saving and energy-saving requirements.



GENERAL NORMS

ENGLISH

Tank You for purchasing our Dishwashing Machine.

Perfect washing-up results as far as hygiene concerns and a correct operation of the dishwashing machine can be assured only in case the instructions reported in the present manual are carefully followed.

We hope the information reported in the present manual will be helpful to You.

They are based on data and our best updated knowledge.

Carefully read the Instructions reported in the manual, recommendations and suggestions included. Carefully read the terms of sale too, the ones limiting warranty included.

INTRODUCTION AND SAFETY NORMS

INTRODUCTION

This equipment is destined only to the use it has been conceived for: tableware washing such as dishes, glasses, cups, cutlery, trays, etc. Using it to wash machine components or objects whose dimensions are superior to the machine working passage is improper and therefore dangerous.

- Equipment in compliance with EEC89/336 directive concerning the suppression of radio interferences and electromagnetic incompatibility.

- In conformity with the EEC directives and the fulfilment laws, our dishwashers are built according to the regulations in force in Italy and abroad.

- The noise of the machine running empty, measured at the working positions (fig. 1) and at 1.6m from the floor, is the following:

	position 1	position 2	position 3
Leq A Level equivalent of sound pressure dB(A)	70	68	70

The level of peak sound pressure L_{pc} is not declared as it is much inferior to 130dB(C):

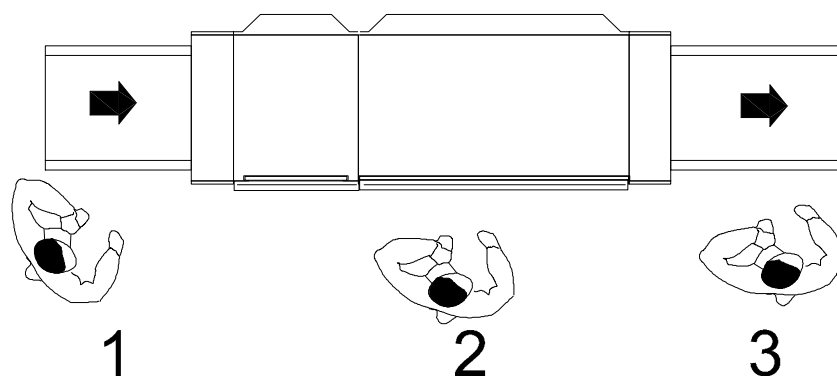

PRELIMINARY OBSERVATION

Carefully read the instructions reported in the present user manual, as it gives important indications about safety of installation, operation and maintenance:

- **carefully keep the present manual for further consultations;**
- the illustrations and drawings showing the machine are intended for general reference only and are not necessarily accurate in every particular;
- the dimensions and characteristics of the machine, given in this Manual, are not to be considered binding and may be changed without prior notice;
- having removed the packing material, check that all the equipment is present. If there is any doubt, do not use it and contact qualified personnel. The packing elements (plastic bags, nails, etc.) should be kept away from children, because they are dangerous.

GENERAL SAFETY REGULATIONS

THIS SAFETY CODE HAS BEEN COMPILED IN YOUR INTEREST. Strict adherence to these rules will reduce the risks of injury both to yourself and to others;

Personnel working with this machine must adhere strictly to all statutory safety regulations as well as the specific rules listed below. Failure to do so may result in personal injury and damage to the machine;

- DO NOT attempt to move, install, set-up or operate this machine until you have read and fully understood this Manual. If doubt persists, ask your supervisor;
- never leave tools, parts or other loose material on or in the machine;
- Before switching the equipment the equipment on, make sure that the model plate data conforms to that of the electrical and water distribution network;
- remember that even with the mains isolator in the "OFF" position, the incoming cables are still live;
- BEFORE starting machine o cycle, after any maintenance or repair work, make sure all protective are correctly installed;
- be vigilant at all times, remember that your safety and that of your fellow workers depend on you;
- when moving or lifting the machine, care must be taken to comply with all the relevant regulations governing such operations;
- installation should be carried out by qualified personnel according to the manufacturer's instructions.
- this equipment should be destined to the use which it has been conceived for. Any other application should be considered improper and consequently dangerous;
- the equipment should only be used by personnel trained for its use;

SPECIAL SAFETY REGULATIONS

- ajustement and repairs must be carried out only by personnel qualified. Repair carried out by unskilled personnel may be dangerous;
- perfect washing-up results as far as hygiene concerns and a correct operation of the washing machine can be assured only in case the instructions reported in the present handbook are carefully followed;
- the machine must be only used by authorized personnel which must comply with sanitary measures;
- do not leave the machine in environment with temperatures inferior to 0°C;
- the machine protection degree is IP55 for Control board and IP32 for machine, **therefore it should not be washed with direct high pressure jets of water;**

UNPACKING AND DELIVERY CHECKS

When the case with the machine has been received, unpack it as follows:

- Remove the upper cover and the wooden case side walls, take care not to damage the machine,
- Remove possible accessories boxes,
- Remove the protecting cellophane,
- Make sure that the machine has not been damaged during transport,
- Make sure that all covers and panels have been correctly fixed and that no loosen part is present,
- Visually inspect that all electrical components are integral.

TRANSPORT AND INSTALLATION

- To lift and transport the machine, insert the truck forks under the frame connected to the points indicated by the yellow adhesives applied on the machine front side (see draw below).

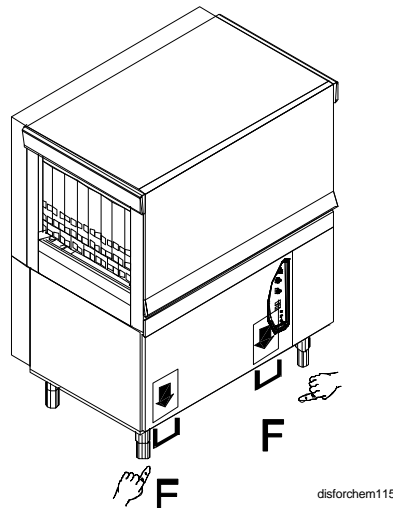

draw "A"*

- Before plugging the machine, make sure that the supply voltage of the domestic wiring system and the water supply from water connection corresponds to the ones reported on the rating plate
- Installation should be carried out by qualified personnel according to the manufacturer's indications

During instalation, it is recommended to level the machine in order to ensure a correct operation.

INSTRUCTIONS FOR THE USER

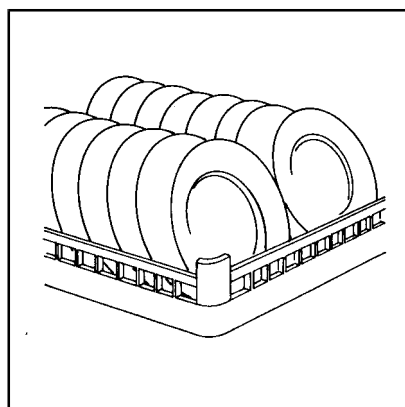

1

First Section - FOR THE USER

OPERATION BEFORE WORKING

BEFORE STARTING THE WORKING OPERATION BE SURE THAT:

- the wall-mounted on/off switch is switched on;
- the water and steam* cocks are open;
- water and steam (*) are present in the system;
- the filters and the overflow are in their housings (Check the seal by - pushing the overflow to the bottom and rotating it slightly). (Attention! The machines which are provided with built-in drain valve do not have overflow).
- curtains are correctly positioned;
- the inspection doors are closed;
- the dimensions of the dishes to be washed do not exceed the washing working dimensions;
- Check that the detergent and rinse aid containers are not empty.
- Switch the machine on . Go to the page dealing with the model selected .

(*) for steam machines only

DETERGENTS

In case the machine is not provided with an automatic dispenser, pour the detergent directly into the washing tank and uniformly distribute it on the filters in the doses indicated by the supplier.

N.B.: If you make use of chlorinated sanitizers, **it is always advisable to employ an automatic dispenser with feeler for the measurement of the detergent concentration**, because brownish spots can form on the surfaces due to chlorine reactions when pouring the detergent directly into the tank.

In any case the product shall be introduced near the pump suction pipe in the tank and at least 15 cm far from the bottom in order to avoid corrosion.

Choice of the suitable cleansing agent is an essential condition if you want to obtain extremely good washing results as concerns hygienic results. It is then important to consider some points. First of all only highly alkaline and chlorine-active antifoam products, especially made for industrial dish-washing machines, must be used and they must be produced by well known reliable Firms.

Mean concentration of the cleansing agents in powder must be 1,5÷2,5 g/l. Mean concentration of liquid cleansing agents must be 2÷4 g/l.

In order to avoid scales and corrosions, put cleansing agent above water level on the nearest area of the sucking pump filter, in this way it will immediately dilute and will not deposit on the tank bottom.

DESCALING

When hard water is used you can find, inside the machine and also on objects, calcareous sediments which must be removed both for hygienic and operating reasons by a descaling operation.

Operating process and frequency of this intervention are suggested by your cleansing agent supplier who has suitable products, generally containing phosphoric acid.

In order to avoid damage to the machine do not increase the quantities and once operations end rinse abundantly.

HYGIENE

At last each 30 days it would be useful to do this operation which guarantees the complete hygienic conditions of the machine. We suggest to contact your cleansing agent supplier who will give you quantity and name of the most suitable product you can use and that, generally, is an active chloride powder (100÷200 ppm).

In order to avoid damage to the machine do not increase the quantities and once operations end, rinse abundantly.

**SWITCH-ON AND USE OF THE DISHWASHING MACHINE
MOD. M115**

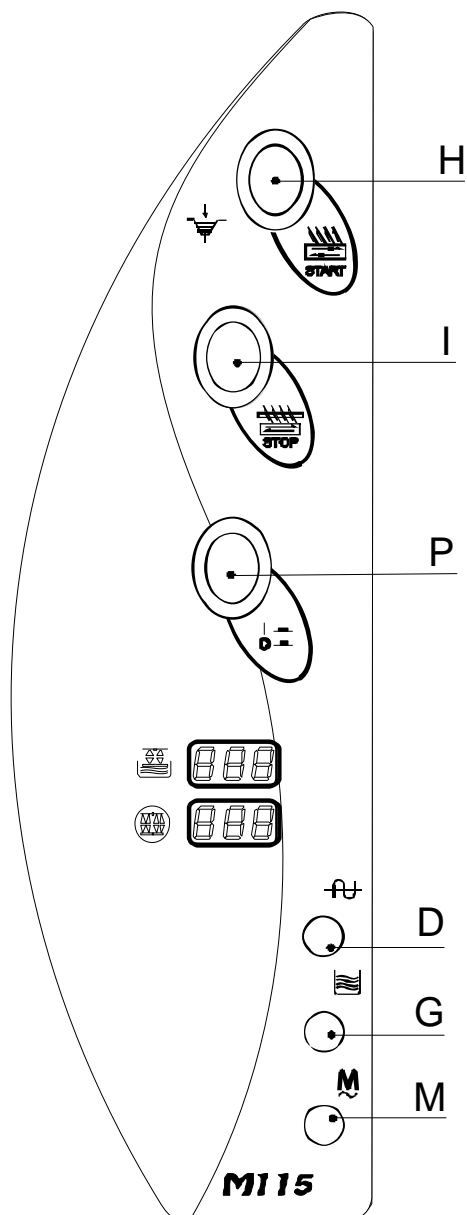

LEGEND

- M – Overload cut-out indicator
- G - Machine ready indicator
- D – Machine on indicator
- I - Stop pushbutton
- H – Start pushbutton
- P – Switch ON/off

1) Push on/off switch "P" to position "ON" . Line lamp "D" turns on and the tanks start being filled automatically . Lamp "G" turning on indicates that the appropriate level has been reached in the tank and the heater element have been switched in the circuit .

2) Wait until the washing temperature is from 55° to 60° C and the rinsing one is from 80° to 85° C. Check the thermometers on the front panel .

3) Then push the start button "H". Washing starts and the racks move. Rinsing is operated automatically in correspondence with the dishes passing through .

4) At this point the machine is ready to wash the dishes (see page 17) .

5) Should it be required to stop the washing operations, push the button "I" to stop the rack moving.

Conversely, if the dishwashing machine has to be switched off completely, set switch "P" to position "O" .

The machine is equipped with a red mushroom-shaped pushbutton "P" on yellow field, which, if pressed, stops all motors. Once the trouble has been removed, it is possible to restart the machine only after the pushbutton has been rotated and released. Subsequently press the start button "H" again.

For subsequent operations, refer to the maintenance chapter .

ELECTRONIC DISHWASHER STARTUP AND USE

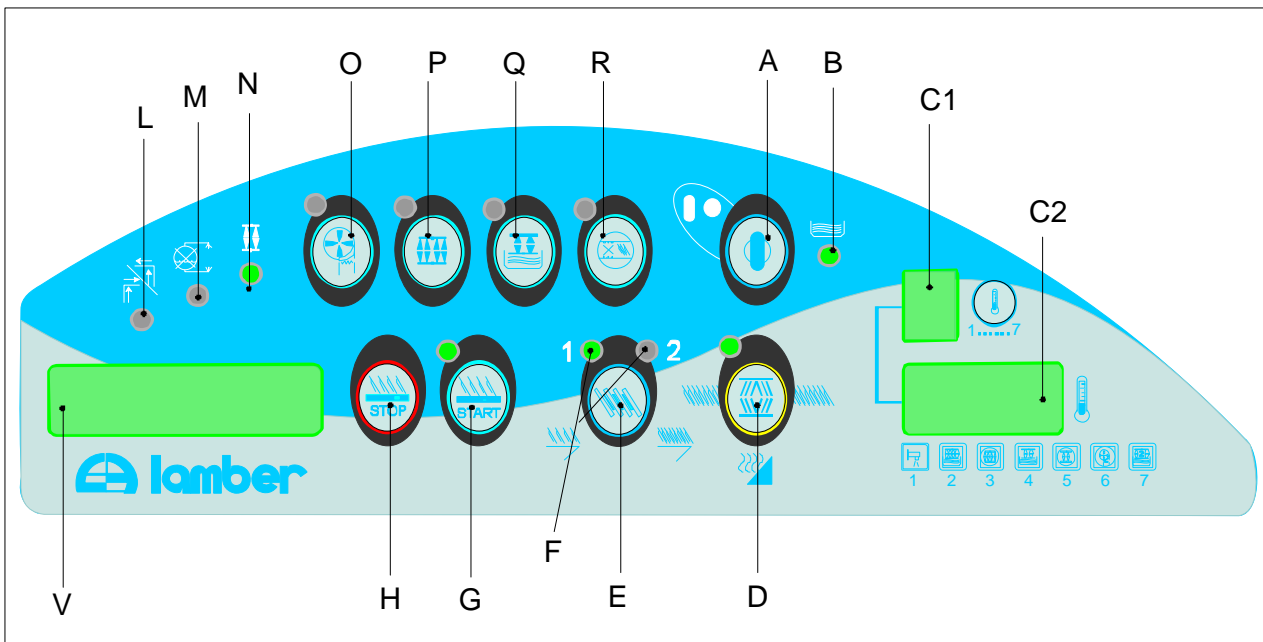

Turn the voltage on by pushing the main button located on the control panel. The thermometer display C1, C2 lights up. Then follow the instructions:

- 1) Push the line button "A".
Display information "V" will light up (ON LEVEL) and automatically start the tank loading (lamp "B" is blinking). When lamp "B" turning on indicates that the appropriate level has been reached in the tank and the heater element has been activated (the display visualizes MACHINE READY).
- 2) Wait until the washing and rinsing temperatures reach respectively 55°C to 60°C and 80°C to 85°C. Check the temperature of thermometers.
The display C1 indicates the number of the probe connected to the temperature indicated on display C2.

pos.1 : water inlet temperature;
pos.2 : washing temperature;
pos.3 : rinsing temperature;
pos.4 : pre-wash temperature;
pos.5 : pre-rinse temperature;
pos.6 : drying temperature;
pos.7 : second washing temperature.
pos.8 : option.

- 3) Then push button "D" (led on).
The machine is ready to wash the dishes (the information display visualizes now WASHING ENABLED).
- 4) Select the conveyor speed according to the objects to wash, and push button "E" (led "F" corresponding to the selected speed will light up).
- 5) Push the START button "G" to start the washing and to move the racks (the display information visualizes now IN CYCLE).
- 6) Introduce the rack in the tunnel and follow the warning instructions indicated on paragraph "washing instructions" (see pag. 17).
- 7) The rinsing operation starts automatically at the passage of the dishes (led "N" lights up) (the display visualizes now IN RINSING CYCLE).
If the lamp does not blink there is a problem at the rinsing electrovalve (call a qualified technician).

- 8) Should it be required to stop the washing operations, push button "H" to stop the rack from moving.
- 9) To stop temporarily the rack basket from moving and to interrupt the washing, push the button "D" on OFF position (led off). The other heater elements stay ON (Standby position).
- 10) To turn off the Dishwasher, push the button "A" (led "A" off).

Checking Device:

The display "V" is blinking and visualizes the writing "Door open", it indicates that one of the door was not closed correctly.
Close the door again.

The display "V" is blinking and visualizes the writing "Roller conveyor stop activated", take out the basket at roller conveyor stop.

The display "V" is blinking and visualizes the writing "motor Alarm!", it means that there is a problem at the overload cut-out indicator.
Call a qualified technician.

During the normal operation of the Dishwasher the **display "V"** will help you to understand which operation the machine is performing.

The display "V" is blinking and visualizes the writing "**CALL SERVICE!**". The display inform that the maintenance is necessary. The SERVICE function allows to program the maintenance interventions that have to be done on the machine, according to the kind of use. Call a qualified technician.

Optional Devices:

If the machine is equipped with a Drying tunnel it is possible to activate the function of

this optional device by pushing the button "O" (led on);

If the machine is equipped with a pre-rinsing device, it is possible to activate the function of this optional by pushing the button "P" (led on);

If the machine is equipped with a heat pump, it is possible to activate the function of this optional by pushing the button "Q" (led on).

WASHING AUTOTIMER (optional)

Thanks to the AUTOTIMER device it is possible to reduce water and power consumption when the machine is not used.

To activate this function, push the button "R" (led on).

HEAT PUMP (optional)

The system exploits the heat produced in the cooling cycle, which allows to constantly regenerate energy from the hot air produced in the machine, to preheat the rinsing water.

This device allows to feed the machine with cold water, so as to save a lot of energy (at least 15,5 Kw).

FLOWMETER RINSING (optional)

It checks the water flow is enough for a good final rinsing cycle. The blinking led "M" indicates a possible failure.

PREWASHING CORNER TUNNEL (optional)















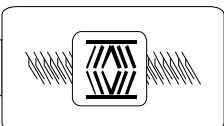
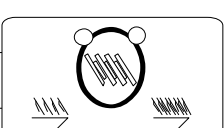

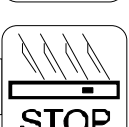
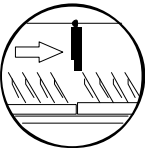
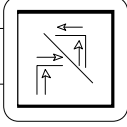
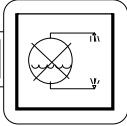
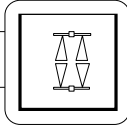
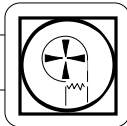
If a PRE-WASH CORNER TUNNEL is installed, the machine indicates when it is possible to insert the basket into the corner tunnel.

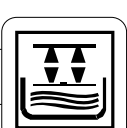
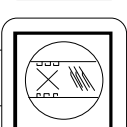
The led "L" .marked with the symbol () lights up when there is a basket inside the corner tunnel.

Once the transport slide has been completed and the tunnel is free, the led "L" goes off: this indicates that it is possible to insert another basket.

"Attention! This unit cannot be connected to any automatic basket loading system. Baskets can be introduced only by hand and by an operator."

SYMBOLS USED FOR THE CONTROLS

- | | |
|--|--|
| <p>A  MAIN ON/OFF SWITCH and MACHINE LOADING</p> <p>B  MACHINE ON LAMP</p> <p>C1  DISPLAY TEMPERATURE NUMBERS</p> <p>C2  TEMPERATURE DISPLAY</p> <p>D  CONTINUOUS WASHING</p> <p>E  SPEED BUTTON</p> <p>G  START PUSHBUTTON</p> <p>H  STOP PUSHBUTTON</p> <p> TENTS POSITION</p> | <p>L  CORNER LOADING ON</p> <p>M  FLOWMETER</p> <p>N  RINSING ON</p> <p>O  DRYING ON</p> <p>P  PRE-RINSING ON</p> <p>Q  HEAT PUMP</p> <p>R  TIMED WASHING, FOR MACHINES WITH AUTOTIMER</p> <p>1  WATER INLET THERMOMETR</p> <p>2  WASH THERMOMETER</p> <p>3  RINSING THERMOMETER</p> <p>4  PRE-WASH THERMOMETER</p> <p>5  PRE-RINSING THERMOMETER</p> <p>6  DRYING THERMOMETER</p> <p>7  SECOND WASHING THERMOMETER</p> <p>8  OPTIONAL</p> |
|--|--|

QUMA-EK-SIMB-GBR

WASHING OF DISHES

- 1) First of all, remove any food residues and any oily masses .
- 2) Knives , forks and spoons should be previously softened; the same applies to dishes, should they be washed a long time after their use .
- 3) Arrange the dishes as shown in the figures (page 18) .
- 4) Push the rack toward the inlet of the machine. The feeding system will make it step up automatically . (N.B. Insert the shelves so that dishes are faced to the inlet and trays are parallel to the machine).
- 5) If the operator is not in a position to remove the shelves from the outlet bracket, they, upon reaching the end thereof, would cause the feeding system and rinsing to stop. In order to restore the operating conditions, it is sufficient to remove that shelf that operates limit switch micro .

DURING WASHING OPERATIONS

- 1) Check that the water temperatures are in accordance with the specified values .
- 2) Monitor the levels of the detergent and the rinse agent liquid in the respective containers .
- 3) Remove the filters periodically and remove any residues therefrom; it is suggested to buy another spare filter in order not to have to stop the machine for an extended period of time .

4) Avoid dipping your naked hands into the soapy hot water present in the tanks. This can cause burns and skin irritations. In this case, immediately rinse them with plenty of water.

5) When the machine is working, do not open the inspection doors too quickly.

6) In case the conveyor belt is stopped by the safety device (limit switch), stop the machine by means of the red emergency mushroom pushbutton located near the operator before removing the obstacle causing the trouble.

7) Deactivate the equipment in case of fault or malfunction. For repairs, only address to a technical assistance center authorised by the manufacturer and impose the use of original spare parts.

The non-observance of the above could compromise the safety of the appliance and of the operators.

For possible troubles occurring during the working cycles, see the relevant chapter.

BASKETS



PP12/16



CB



G8



CVA (option)

**TAKE CARE !
BASKETS WITH DISHES
OR TRAYS MUST BE PUT
INTO THE WASHING
TUNNEL AS SHOWN
IN THE PICTURE.**

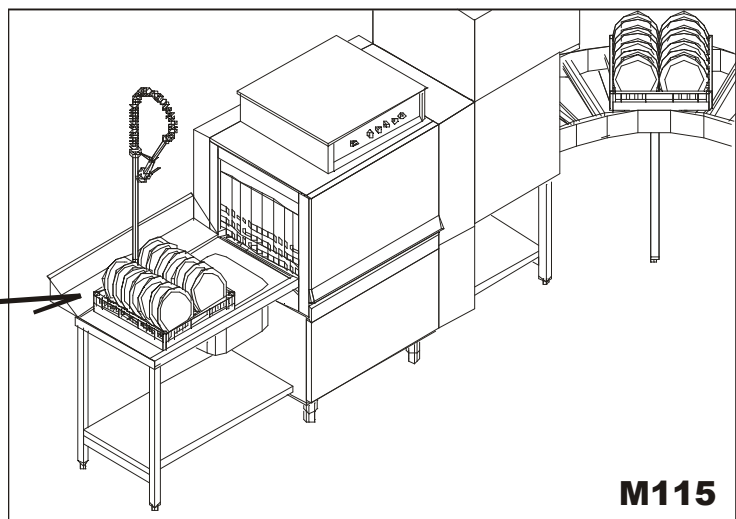

M115

AFTER WASHING OPERATIONS

PRECAUTION AND CLEANING INSTRUCTIONS

- high temperatures can be reached inside the machine (90°C). After power supply has been removed, wait until the machine has reached the room temperature, before working on it;
- never leave tools, parts or other loose material on or in the machine;
- BEFORE starting machine or cycle, after any maintenance or repair work, make sure all protective are correctly installed;

At the end of the working operations:

- 1 – Push the STOP button “I” and rotate the switch "T" to position "0".

For machines with Drying system:

Push the STOP button “H” and rotate the button "A" to switch off the machine.

Attention! For machines with Drying system it is necessary to *wait 5 minutes* before pushing the button "A" to switch off the machine;
This make Fan able to cool elements.

Tank drain by drain valve

In case of machines equipped with built-in drain valve, it is necessary to push the button “D” at the end of the working process for 3 seconds:

-The LED will flash and on the information display you will read “TANK DRAIN” (attention! The “A” button has to be on switch-off position).

-After two minutes the drain stops automatically.

2 - Take off the machine by means the disconnecting switch located on the control panel.

3 - **IMPORTANT:** Before carrying-out the cleaning and maintenance operations, disconnect the equipment from the mains voltage through the wall-mounted on/off switch and close the water and steam* supply cocks;

4 - Lift the inspection doors making sure that they are firmly linked to the apposite support.

5 - Lift the overflows to empty the tanks.

6 - Wash the inside of the machine with a water jet. When everything is clean and water is completely drained, take out and clean carefully the flat filters and that of the pre-wash (if any) and wash them carefully every day (don't beat them against the floor or others) .

7 – When the tanks are empty remove and wash the slide filters and the suction pump filters .

8 – Remove and wash the splash-guard curtains.

9 - For machines with steam condensation only, remove the steam aspiration filter (fig.5) and clean it.

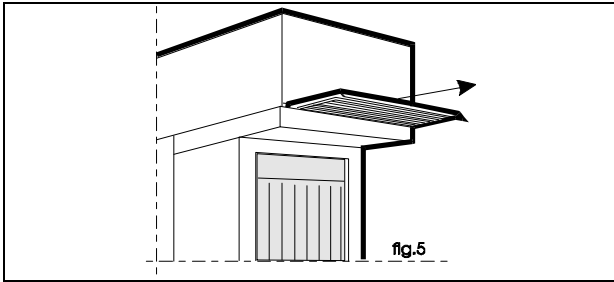

- 10 - Check that the washing nozzles are not clogged. If necessary, disassemble the nozzles and pay attention to assemble them again in the right position (twice a week).
- 11 - Remove the rinsing arms by rotating them counter-clockwise and check that the nozzles are not clogged: if otherwise, clean them using a needle (every week).
- 12 - Replace the filters taking care that: Curtains shall have their shortest side turned towards the basket inlet (see the blue signalling marks located on the doors)
- 13 - Clean the outside part of the machine using a wet sponge .Don't use water jets that, beside being dangerous, could also damage the electrical parts.
Don't use deterative, abrasives, steel-wools or steel-brushes.
- 14 – In order to avoid the formation of nasty smells, let the doors open making sure that they are firmly linked to the apposite supports.

* for steam machines only

Machine prolonged stop

In case the machine is not used for some weeks it is advisable to carry out an accurate cleaning of all components inside

to avoid the formation of unpleasant smells.

In case of a very long standstill, it is advisable to oil the stainless steel surfaces with white mineral oil.

HELPFUL SUGGESTIONS

MAINTENANCE

IMPORTANT: Before carrying out cleaning and maintenance operations disconnect the machine from the power supply source by means of the wall-mounted switch or by means of the disconnecting switch located on the control panel.

WARNING! - Do not disconnect the switch when the machine is on!

Check and frequently clean the nozzles. The frequency at which such operation shall be carried out will be suggested by the quantity of residues and scales and by the unsatisfying washing results.

To clean the machine outside and inside, never make use of corrosive products such as sodium hypochlorite (bleach) and hydrochloric acid (muriatic acid), acids in general, wire wool and steel brushes.

To avoid compromising the correct operation and to keep the appliance in optimal hygienic conditions, it is advisable to carry out periodical sanifications and scale removing operations.

ACHIEVEMENTS

Any deficiency in the washing process is apparent when dirty residuals are visible. Any halos might be caused by an insufficient rinsing: in this case, check that the rinsing jets are clean and there is

a sufficient pressure in the water distribution network (2÷4 bar) ;

In the case that residuals are present, check that:

- the washing jets are clean
- pre-washing temperature is 40 °C maximum;
- washing temperature is from 55 to 60 °C,
- rinsing temperature is from 80 to 85 °C,
- there is detergent in the right concentration;
- the filters are clean;
- washing water is not dirty;
- the positions of the objects in the rack are correct.

SAFETY DEVICES

The dishwashers are equipped with a number of devices in order to ensure the safety of the operator and of the appliance itself.

LIMIT MICROSWITCH

If dishes reach the end of the unloading area, before the operator has managed to unload the basket, the limit switch stops the drawbar motion and therefore the baskets.

DOOR MICROSWITCHES

Each inspection door is provided with two safety microswitches forming two redundant chains (safety level 2).

If one of the doors is opened accidentally, the pumps, the conveyor belt gearmotor and the rinsing area solenoid valve stop working.

This way all washing operations are stopped preventing dangerous jets of hot water from spurting out.

Operation is restored only when the door are closed again and the start button "H" pressed.

In case of appliances with more complex layouts, more pushbuttons near the operator can be necessary.

EMERGENCY STOP PUSHBUTTON

The machine is equipped with a red mushroom-shaped pushbutton on yellow field, which, if pressed, stops all motors. Once the trouble has been removed, it is possible to restart the machine only after the pushbutton has been rotated and released. Subsequently press the start button "H" again.

More pushbuttons may be necessary near the operators depending upon the appliance washing characteristics.

TORQUE LIMITER

The drawbar forward feeding system is provided with a mechanical friction torque limiter located in the drawbar system.

Each time something interposes between the basket and the machine or the central drawbar is overloaded, the bar motion lowers rapidly to zero.

In this case it is necessary to switch the machine off by means of stop or emergency pushbuttons, remove the obstacle and press the start button again.

To calibrate this kind of device, see the relevant chapter included in the second part of the manual dedicated to the installer.

MOTOR PROTECTION DEVICES

Each motor is protected against short-circuits and current overload by automatic magneto-thermal relays.

Lamp "M" switching on signalizes the intervention of any of these relays.

In this case, the machine should be switched off and qualified personnel should be asked for repair.

ELEMENTS PROTECTION

Each element is protected against short circuit by automatic breakers.

Tank elements are protected against dry running by minimum level pressure switch. Boiler and dryer elements by thermostats with manual reset.

In case of troubles, ask for the intervention of qualified and authorized personnel (see the paragraph dedicated to the user).

RESIDUAL RISKS

Although the appliance is equipped with the above-mentioned safety devices, danger of burns to upper limbs persists.

As already mentioned in the paragraph "DURING WASHING OPERATIONS", avoid dipping your naked hands into soapy hot water of the tanks. This can cause burns and skin irritations.

In this case, immediately rinse them with plenty of water. Anyway consult the product card of the detergent employed.

WASHING FLOW CONTROL SYSTEM

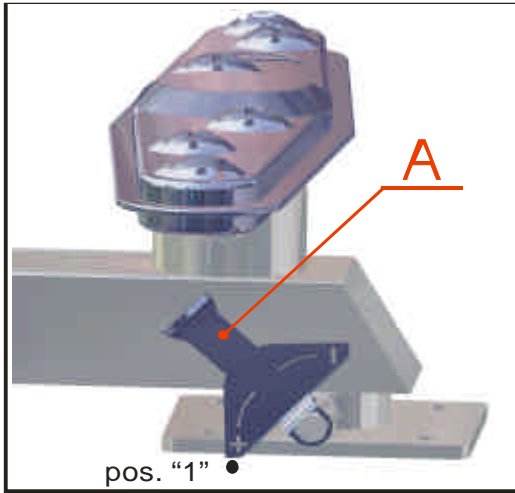

Highest power (position 1)

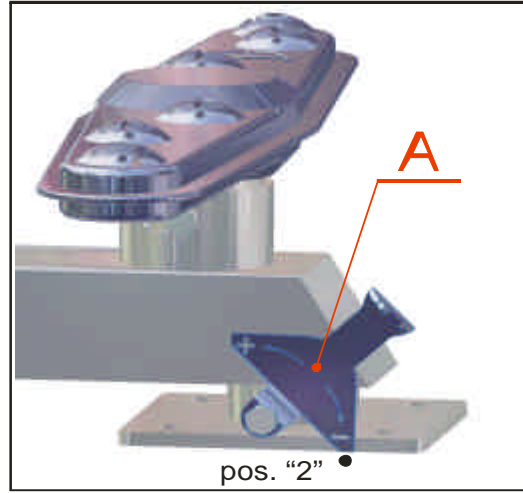

Lowest power (position 2)

The flow control system is a device that allows You to act on the intensity of the washing power.

This can be useful by washing glasses, when it is necessary to reduce the washing jet power.

This device is placed into the pre-washing and washing areas of the rack conveyor dishwashing machines, by the lower washing arms group.

In order to act on the control system You have to rotate the lever "A" by hand anticlockwise to rise the washing jet power and clockwise to reduce it.

If You turn it thoroughly leftwards, You get the highest power (pos.1).

If You turn it thoroughly rightwards, You get the lowest power (pos.2).

USEFUL HINTS OF STAINLESS STEEL MAINTENANCE

Stainless steel is so called because it is not affected by oxidation, this is due to a thin molecular layer of oxide on the surface which protects against further oxidation. There are, however, substances which can modify or destroy this layer, giving rise to corrosion: besides preventing the protective film of oxide from reforming, these substances corrode the stainless steel itself and can cause irreparable damage. It is therefore necessary to prevent this by choosing correct cleaning products and by complying with the following simple recommendations: **never forget that when using these appliances, the first and fundamental rule is to guarantee that the cleaning products are both non-toxic and hygienic.**

Before using any detergent to clean either the stainless steel or the immediate and surrounding floor area, always ask your supplier for the most suitable product which does not cause corrosion on the steel itself; the onset of rust is most commonly caused by the use of unsuitable cleaning materials (strongly acid chlorate based detergents) or on inadequate maintenance.

Our appliances are made of stainless steel AISI 304 (18-10 type) for exterior panelling, upper tops, tanks etc.

Comply with the following instructions when cleaning and servicing parts in stainless steel.

Ordinary daily maintenance

Carefully and frequently clean the surfaces using a damp cloth; use soap and water or normal detergents, **so long as these do not contain abrasives or chlorine based substances** such as sodium hypochlorite (bleach), hydrochloric acid or other such solutions: These products quickly and irreparably corrode stainless steel. When cleaning floors underneath or near the appliances, never use the above mentioned products as vapours or splashes could subject the steel to similar destructive effects.

Only ever rub in the direction of the satining, then thoroughly rinse with clean water and carefully dry.

Rust : water supply pipes, inevitably convey particles of rust dissolved in the water especially in new installation plants or when taps are opened after a period of inactivity. These iron deposits must not be allowed to remain on the stainless steel since they produce rust by contamination.

Use suitable products to remove any rust marks, from companies which produce detergents for industrial use. After application, thoroughly rinse with clean water, neutralizing the action of the product with an alkaline detergent normally used to clean such appliances or with another specific product.

DO NOT USE METAL MATS TO CLEAN THE STAINLESS STEEL

INSTRUCTIONS FOR THE INSTALLER

The following instructions are addressed to a qualified personnel, the only one authorised to carry-out checks and repair, if any.

The Manufacturer declines any responsibility in the case of interventions made by a non qualified personnel.

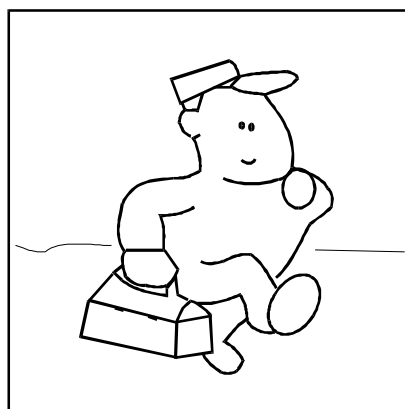

2

Second Section - FOR THE INSTALLER

The following instructions are addressed to qualified personnel who is the only one authorized to carry out the inspections and the necessary repairs.

The machine should be installed in "Normal" environment, that is to say, indoors, free of dust, explosion-proof and adequately lit and well aired.

Before installing the machine, it is necessary to arrange the electric and water connections.

See the reported wiring diagram (supplied by the manufacturer) of the selected model as far as the dimensions of pipes, cables and wall-mounted switch are concerned.

In order to prevent damages caused by the escape of vapours from the equipment, make sure that adjacent materials do not deteriorate in their presence.

The Manufacturer cannot assume any responsibility for any damage to persons or property deriving from the non-observance of the above specified norms.

DETERGENTS

The machine should also be equipped with a detergent and brightener dispenser, which shall be supplied by the manufacturer of these products.

N.B.: If you use chlorinated sanitizers, **it is always advisable to employ an automatic dispenser provided with feeler for the measurement of the detergent concentration**, because brownish spots can form on the surfaces due to chlorine reactions when pouring the detergent directly into the tank. The feeler for the measurement of concentration must be placed on the front side of the tank through the hole "**A**" preset for such operation (see drawing on page 28).

In any case **the LIQUID DETERGENT** shall be introduced through the preset hole "**B**" on the right side of the washing tank.

Choice of the suitable cleansing agent is an essential condition if you want to obtain extremely good washing results as concerns hygienic results.

It is then important to consider some points.

First of all only highly alkaline and chlorine-active antifoam products, especially made for industrial dish-washing machines, must be used and they must be produced by well known reliable Firms. We provide a short list just as an indication: Ecolab-Soilax; Henkel; Lever; Diversey; Relativ.

The average concentration of liquid detergents must be 2÷4g/lter. In any case it is essential that the producer of the detergent rules the dosage properly according to the features of the installation.

As regards the introduction of the **liquid rinse aid product**, use the passage "**C**", placed near the water inlet group.

This coupling will allow an appropriate introduction of the liquid rinse aid product. In order to do this use a fitting with non-return valve.

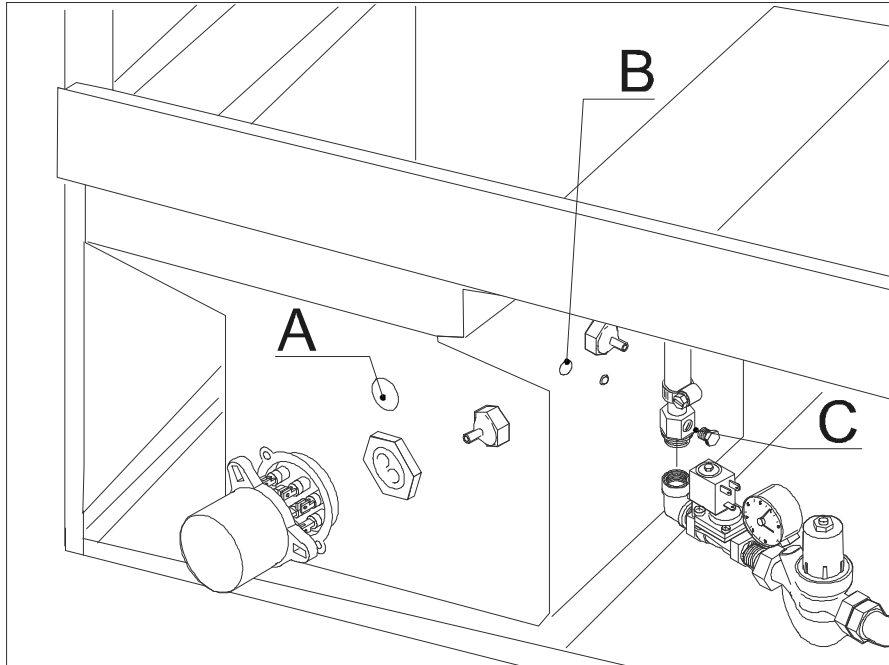

For the electrical connection of these dosing pumps join the **auxiliary contacts** of the contactors MT5 (detergent pump) and MT4 (rinse aid pump) into the lower electric box (standard M115 model) or the **blue terminals** into the upper electric box (M115 with drying tunnel), marked by special tags.

Note: In order to let cables pass, please use the labelled wire clamp behind the electrical control box.

DISPOSAL

At the end of its life, the machine shall be disposed according to the local laws in force by specialized and acknowledged companies in this field. Its components shall be distinguished as follows:

- metallic components: body, plans, frames, filters;
- electric components: motors, remote control switch, microswitches, wiring;
- plastic components: baskets, connections;
- rubber components: hoses, sleeves.

POSITIONING

During installation, carry out a good levelling of the machine in order to make it correctly work (doors, basket forward feeding). In order to do so use the adjustable feet.

After removing front panels, position the machine over the connections. Assemble the inlet and outlet shelves for basket loading and unloading. The limit switch FC1 is located on the outlet shelf or on the machine delivery if the shelf is not provided for. The limit switch shall be connected to the outlet shelf.

The machine shall also be equipped with detergent and brightener dispenser, which shall be supplied by the manufacturer of these products.

ELECTRICAL CONNECTION

Before connecting the machine, check to make sure the voltage outlet of the mains is the same as the voltage specified on the data plate of the machine.

It is also necessary to check that the counter, the mains and the intake are adequately dimensioned to withstand the required maximum load.

A main switch must be installed between the mains and the machine. This safety measure also requires that the minimum distance between the switch contacts is at least 3 mm and the disconnection on all poles according to **EN 60204 (VDE 113)**.

The mains must be wired to be able to handle the current drawn by the machine. The system must also be provided with a proper ground lead in accordance with the existings norms. The

electric cable must be of the following type **H07RN-F**.

See specification on page 2 .

For a correct selection of the cable rated cross-section refer to the data reported on the product data plate.

The cable cross-section shall not be inferior to the one indicated in the "Technical data and description" reported in the first page of the present manual.

The cable shall be connected to the terminal L1-L2-L3 and to the adjacent yellow-green terminal, on the electric box, it shall be made passed and stopped by means of the apposite cable grip.

It is necessary to connect the equipment to an effective ground installation, as specified by the electrical safety regulations in force.

Chack that this basic requirement is complied with and, in case of doubt, ask for a careful check of the installation by a qualified personal.

In addition, the equipment shall be part of an equipotential system, the effectiveness of which should be checked according to the regulations in force.

The connection should be made at the screw marked by the respective label

located on the equipment lower side (). It is recommended to make the electric line be checked by your own designer.

THE MACHINE SHALL BE CONNECTED WITH AN EFFECTIVE GROUND CLAMP.

The manufacturer declines any responsibility for any damages caused by lack of an effective ground installation.

WATER CONNECTIONS

Carefully comply with any national or regional regulations in force.

Hot water supply

Arrange a gate valve in an easily accessible place, with a tap having a 3/4" gas thread spout at its end and connect to the water inlet valve (fig.1)

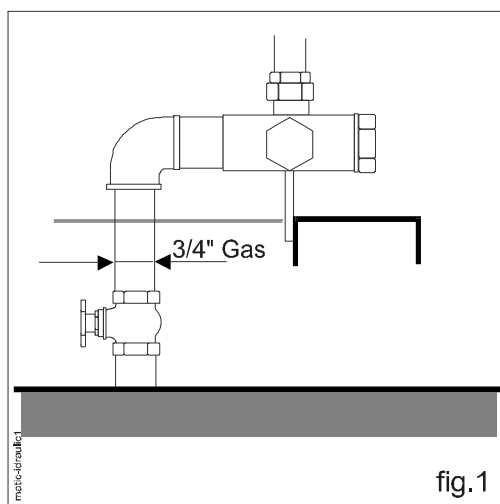

- **temperatur** between 55° and 60°C,
- **Dynamic Pressure** 2÷4 bar (200÷400 kPa),
- **Hardness** between 7,2 and 12,5 °F

N.B.: Each machine is equipped with a pressure reducer. In order to obtain an excellent rinsing, it shall be calibrated according to the data reported on the plate located in connection with the reducer itself.

N.B.: Each machine is equipped with a pressure reducer near the water inlet valves.

In order to obtain an optimum rinse it is necessary to adjust it from 0,6 to 1 bar according to inlet water pressure and temperature.

(remember that the required dynamic pressure must be 2÷4 bar (200÷400kPa) and that inlet water temperature must be 55÷60°C for standard machines).

If a variation of rinse pressure is required while installing, proceed as follows:

- 1: make the machine work and check that the rinse is activated;
- 2: Take away the upper protection plug on the reduction gear and turn the proper adjusting screw anti-clockwise in order to decrease pressure or clockwise in order to increase it or to restore the optimum working conditions (see picture 1A).

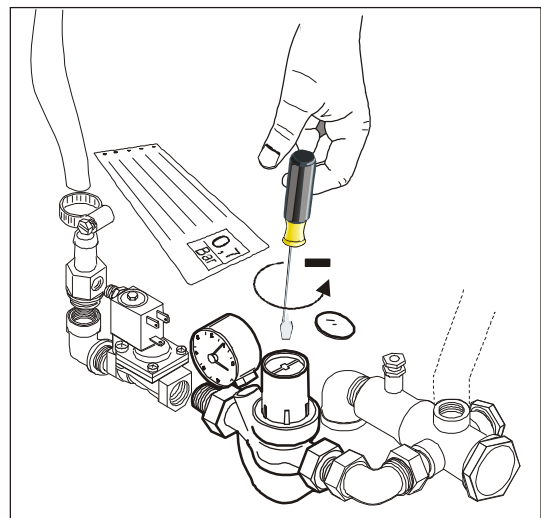

PIC.1A- PRESSURE REDUCER

Cold water supply

This connection is required only for machine with **steam condenser** .

Water shall be supplied at a temperature ranging from 10÷15°C and at a dynamic pressure of 2÷4 bar (200÷400 kPa).

WATER DRAINING

Reachable from the machine front side after opening the front panel (to do this turn the two front screws out);

Arrange a discharge at floor level provided with siphon and connect to the floor drain by means of a hose provided with an adequate inclination. Make sure the drain hose is not choked in any way.

Make sure the drain hose is resistant to a temperature of 70 °C.

Carefully comply with any national or regional regulations in force.

STEAM FEEDING *

As far as steam feeding is concerned, connect to the machine fittings indicated in the installation drawings. In order to make the equipment independent from the general steam distribution network, it is necessary to use gate and gas on/off valves (see draw 2 and 3)..

This type of feeding should be supplied at a pressure ranging from 1 bar (100°C) to 2 bar (121°C).

The steam used should be absolutely saturated and dry.

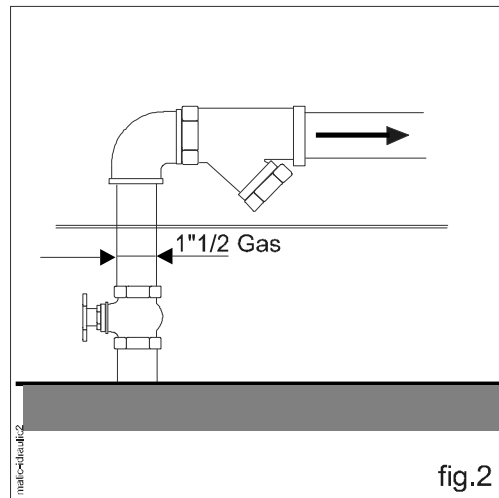

fig.2

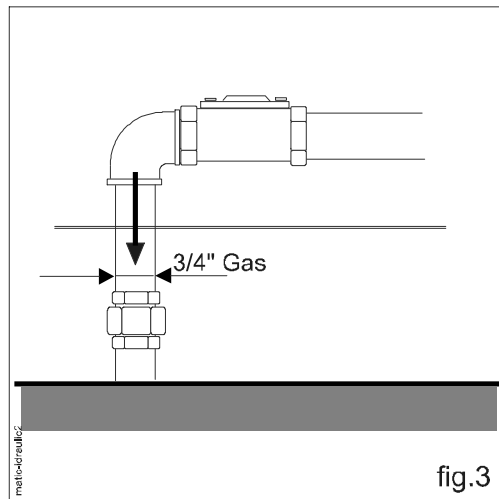

fig.3

STEAM EXHAUST *

The condensed steam exhaust shall have an appropriate slope toward the recovery installation or a blow-by pump, in order to guarantee an autonomous scavenging of the condensed steam.

N.B.: for possible maintenance operations, it is advisable to arrange a gate valve parallel with the discharge so that it is possible to deviate condensation towards a runoff pit.

* for steam machines only

VAPOURS SUCTION

For machines equipped with splashguard with collar or normal collar, carry out the necessary connection as showed in fig. 4.

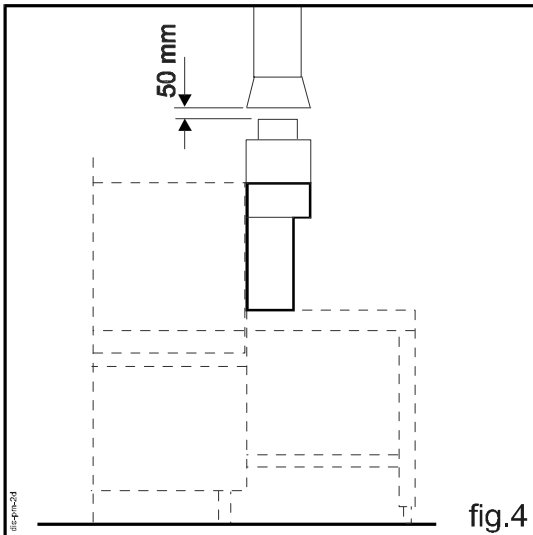

In any case it is necessary to provide a way to scavenge steam through a hood or a similar system.

TESTING

Before starting machine:

During the testing operations, prior to switching the dishwashing machine on, check that thermostat of the rinsing boiler (0°-90° C) is set to zero and the direction of rotation of the pumps is correct.

Should the pumps rotate in the reverse direction, reverse two wires of the line .

Make a number of empty racks to pass through, then check that water jets are sprinkled from the rinsing nozzles then adjust the thermostat of the boiler to 85° C

WORKING TEMPERATURES

Check that the thermostats are set according to the following working temperatures.

WASHING

The tank thermostat (**CT3**), also placed near the wash tank, will be set according to the following temperature:

Washing water: 55±60°C.

RINSING

The rinsing thermostat (**CT2**) will be set according to the following temperature:

Rinsing water: 80±85°C.

DO NOT TAMPER WITH THE THERMOSTAT CALIBRATION

TORQUE LIMITER

The limiter has already been described at paragraph "SAFETY DEVICES".

It is located in connection with the drawbar and it is calibrated during testing by the manufacturer.

In case it is necessary to calibrate it again, proceed as follows:

1. Switch the machine off ;
2. Remove the protection panel;
3. Load the whole drawbar with baskets full of dishes to be washed;
4. Loose the axial ring nut with the hexagon ring wrench type "A";
5. Disengage the friction with a hooked key type "B" so that it slips;
6. At this point clockwise turn until the drawbar manages to carry the whole dishes charge;
7. The device is considered adequately calibrated when the drawbar hardly manages to carry the whole charge in second gear.

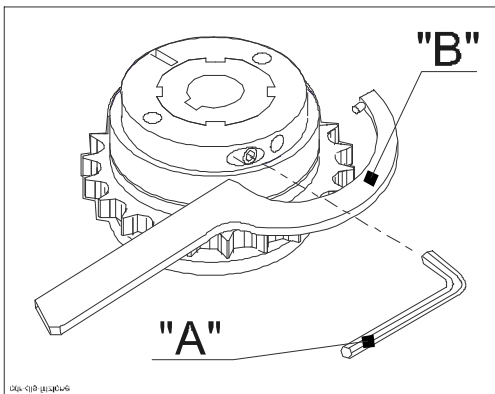

STEAM CONDENSER

As regards the machines provided with “vapour condensing” device, pay attention to the following:

The adjustment of the device is carried out by means of the regulator valve (COCK “V”) placed inside the machine base plate and marked with its special label.

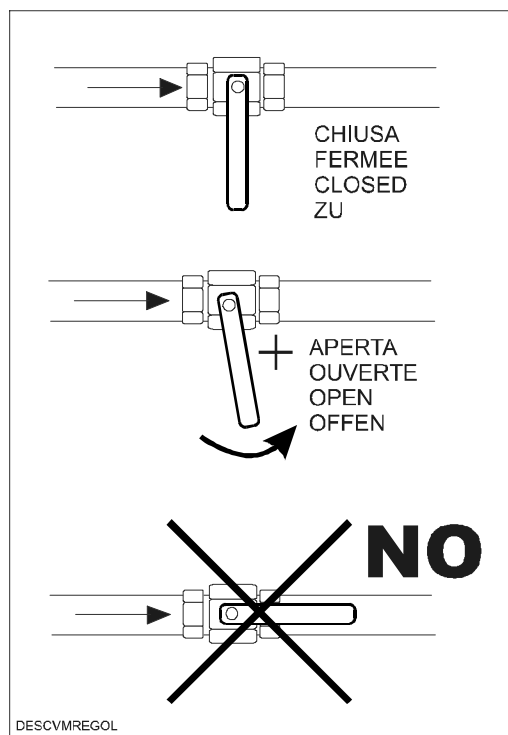
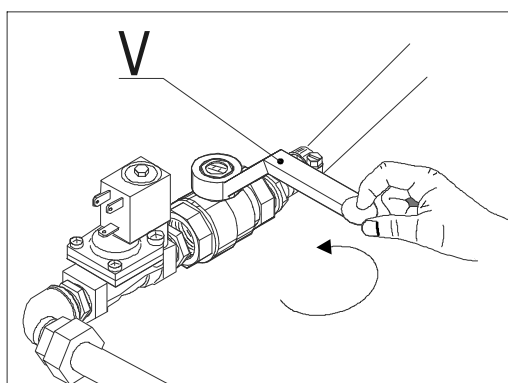

The Manufacturer should rule this cock while testing the machine. Never touch this cock without a specific reason.

This valve rules the water flow in the vapour condensing battery.

If the machine needed a more precise adjustment, under regular conditions, adjust the valve until no more vapour comes out of the “vapour condensing” cap.

Generally it is sufficient to slightly open the valve.

ATTENTION! An excessive opening can cause the cooling of the tank.

MODIFICATION OF PARAMETERS' PROGRAMMING

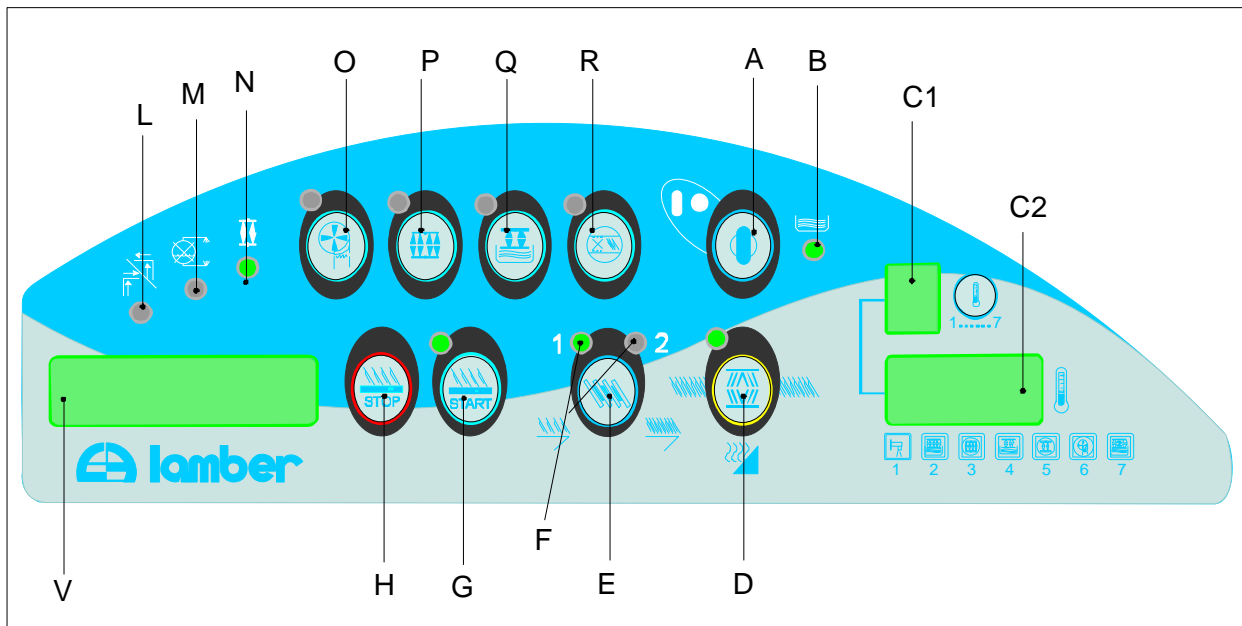

1. Make sure that the wall switch is on;
2. Give power to the machine by the main selector which is placed on the top of the control box: the thermometer display "C1-C2" will turn on, as well as the information display "V", where "OFF" will appear;
3. Push on the "H-G-D" buttons at the same time : on the display "PARAMETERS" will appear ;
4. Push "G"(start) in order to see all the parameters in sequence (see complete list on the following page); (with the "H"(stop) button it is possible to go back to the previous parameter)
5. Modify the parameter acting on the "E" button to reduce and on the "D" button to increase the value of this parameter;
6. To validate the value of the modified parameters it is necessary to push the button "G"(start) until the last "OFF" appears;
7. Push the "A" line button (on the information display you'll see that "ON" will appear);
8. Start the machine and check the right value of the established parameters.

PARAMETERS M115-ASM

Description	Default (Reset)	Modified Parameters
Language	Italiano	
Pre-rinse (Yes-No)	No	
Pre-Rinse Start 1 (0-240s) (first speed)	2s	
Pre-Rinse Start 2 (0-240s) (second speed)	1s	
Pre-Rinse time 1 (0-240s) (first speed)	2s	
Pre-Rinse time 2 (0-240s) (second speed)	1s	
Drying (Yes-No)	Non	
Heat pump (Yes-No)	Non	
Rinse Flowmeter(Yes-No)	Non	
Speed (1-2)	2	
Auto Timer (0-20min)	0min	
Boiler Filling (0-10min)	2min	
Tank Filling Stop (0-240s)	30s	
Tank Filling Alarm (0-60min)	20min	
Rinse Start 1 (0-240s) (first speed)	0s	
Rinse Start 2 (0-240s) (second speed)	0s	
Rinse time 1 (0-240s) (first speed)	1s	
Rinse time 2 (0-240s) (second speed)	1s	
Tanks drain time (0-15min)	0min	
Start after End Switch (0-10s)	3s	
Level (0-240s)	10s	

RESET OF TANK FACTORY PARAMETERS

1- Push buttons **"H"(stop)- "G"(start)- A (I-O)** at the same time.

2- While keeping the above mentioned buttons pushed, give power to the machine by the main selector placed on the top of the control box.

M115-ASM PARAMETERS' DESCRIPTION

<i>Description</i>	<i>Parameter functioning</i>
Language	Select the language to use: Italian-French-English-German-Spanish.
Pre-rinsing (Yes-No)	Select YES only for machines with pre-rinsing. This function can be activated or not by pressing "P" button.
Pre-rinsing Start 1 (0-240s)	a: (for machines with Pull-through rack) lag at the pre-rinsing pump start from the moment of the basket contact with the rinsing economizer at the first speed . b: (for Belt-towing machines) lag at the pre-rinsing pump start from the moment of the basket or dish passage between the entry's photoelectric cells at the first speed.
Pre-rinsing Start 2 (0-240s)	a: (for machines with Pull-through rack) lag at the pre-rinsing pump start from the moment of the basket contact with the rinsing economizer at the second speed . b: (for Belt-towing machines) lag at the pre-rinsing pump start from the moment of the basket or dish passage between the entry's photoelectric cells at the second speed.
Pre-rinsing duration 1 (0-240s)	a: (for machines with Pull-through rack) lag at the pre-rinsing pump stop from the moment of the exit of the basket contact with the rinsing economizer at the first speed. b: (for Belt-towing machines) lag at the pre-rinsing pump stop from the moment of the dish or basket exit from the entry's photoelectric cells at the first speed.
Pre- rinsing duration 2 (0-240s)	a: (for machines with Pull-through rack) lag at the pre-rinsing pump stop from the moment of the basket contact with the pre-rinsing economizer at the second speed. b: (for Belt-towing machines) lag at the pre-rinsing pump stop from the moment of the dish or basket exit from the entry's photoelectric cells at the second speed.
Drying (Yes-No)	Select YES only for machines with drying tunnel. This function can be activated or excluded by "O" button.
Heat pump (Yes-No)	Select YES only for machines with heat pump. This function can be activated or excluded by "Q" button.
Flow-meter (Yes-No)	Select YES only for machines with flow-meter. It checks the rinsing water quantity. Lamp "M" is lighted up when the rinsing functioning is regular; when the water quantity is inadequate lamp "M" flashes and the display shows "RINSING ALERT".
Speed (1-2)	Select -1- for machines with only one speed and select -2- for machines with two speeds. "E" button allows to select the conveyor's or belt-towing 's speed. The corresponding lamp "F" will be lighted up.
Autotimer (0-20min)	Only for machines with autotimer. Select a time from 1 to 20 minutes to activate it. This function anyway can be activated or excluded by "R" button. It stops the machine after the selected time from when the last basket or dish has passed by the rinsing economizer.
Boiler filling (0-10min)	At every daily start, before filling the tanks, the rinsing system is activated to guarantee the water presence in the boiler. Regulate the time according to the single needs or boiler dimensions.
Tank filling stop (0-60s)	Time during which the tank filling has to continue after having reached the level of the level switch to reach immediately the optimal functioning level.

Tank filling alert (0-60min)	Maximum time for the tank filling, after which the machine stops and the display shows this trouble. Alert in case of lack of water or anomaly on the machine drain system.
Rinsing Start 1 (0-240s)	a: (for machines with Pull-through rack) lag at the rinsing start from the moment of the basket contact with the rinsing economizer (at the first speed) . b: (for Belt-towing machines) lag at the rinsing start from the moment of the basket or dish passage between the entry's photoelectric cells (at the first speed).
Rinsing Start 2 (0-240s)	a: (for machines with Pull-through rack) lag at the rinsing start from the moment of the basket contact with the rinsing economizer (at the second speed) . b: (for Belt-towing machines) lag at the rinsing start from the moment of the basket or dish passage between the entry's photoelectric cells (at the second speed).
Rinsing duration 1 (0-240s)	a: (for machines with Pull-through rack) lag at the rinsing stop from the moment of the exit of the basket contact with the rinsing economizer (at the first speed). b: (for Belt-towing machines) lag at the rinsing stop from the moment of the dish or basket exit from the entry's photoelectric cells (at the first speed).
Rinsing duration 2 (0-240s)	a: (for machines with Pull-through rack) lag at the rinsing stop from the moment of the basket contact with the rinsing economizer (at the second speed). b: (for Belt-towing machines) lag at the rinsing stop from the moment of the dish or basket exit from the entry's photoelectric cells (at the second speed).
Tank drain time (0-15min)	Only for machines with automatic drain valve. It fixes the time of the drain cycle.
Start after the conveyor limit stop (0-10s)	Lag time for the restart of the conveyor or of the belt-towing after the stop by the conveyor limit stop to allow to clear the exit table. This lag is activated also at the start of the washing or of the conveyor.
Level (0-240s)	Waiting time for the tank level reset at the washing pumps' start. It can be useful if the machine is equipped with Autotimer and subject to frequent stops and restarts.

A LIST OF DRAWBACKS POSSIBLY OCCURRING WITH THE USE OF THE DISHWASHING MACHINE, THEIR CAUSES AND POSSIBLE REMEDIES

1 - Lamp D (LS1) does not turn on upon switching the machine on

- A - Check that the wall-mounting switch is ON and the respective fuses are not burnt.
- B - Maybe lamp LS1 has burnt. In this case, replace it. The machine can work anyway .

2 - Lamp M (LS3) of overload cutout devices, ON

- A - Check that the overload cutouts of the individual remote switches and replace those disconnected . If such a drawback occurs several times in the same device, it is suggested to increase the current rate through the graduated cursor.
- B - Check that the power supply voltage is not subjected to variations in excess of 10% of the nominal value .
- C - Check, by using an ammeter, that the current drained by the motor does not exceed the rated values .

3 - The tank don't fill, lamp G (LS2) does not turn on

- A - Check that pressure switches CP1-CP2 (those existing) are effective and calibrated.
- B - Check that the feeding water intercept is open and water is present in the piping system .
- C - Check that the overflows are in their housing.
- D - Check that the solenoid valve EV2 is effective and gets tension.

4 - The racks don't step up, feeding rod still

- A - Check that nothing is resting on limit switch micro FC1 and this is in good operating conditions .
- B - Check that there are no objects got stuck inside the tunnel between the feeding group and the fixed part of the machine.
- C - Check that the locking ringnut of the friction clutch in speed reducer M01-M01A1 is not slackened, if otherwise tighten it slowly until the feeding system operates.
- D - Check that the overload cutout RM01 is not triggered, otherwise restore it. This drawback is displayed by lamp M (LS3) being ON .
- E - Check that the remote switch coil MT04 is effective.
- F - Check that speed reducer M01 is in good operating conditions .

5 - The racks don't step up, feeding rod moving

- A - Check whether one or several pawles are blocked .
- B - Check that the central rack of the rack is effective .

6 - The racks don't stop at end of stroke

A - Check that the wheel of micro FC1 projects sufficiently from the bracket and is operated by the shelf.

B - Check that micro FC1 is effective and the respective cable is connected correctly.

7 - The tanks don't stop being filled upon reaching the desired level

A - Check that the trap of the pressure switch has no porosities and the connection pipe is not disconnected .

B - Check that the pressure switch is in good conditions and is calibrated .

C - Check that there is no dirty in the solenoid valve. This drawback can be noted because the machine continues to load water, whilst the main on/off switch is off .

8 - Insufficient washing

A - Check that the detergent is effective, of the type for industrial dishwashing machines, and is proportioned for the right concentration .

B - Check that the detergent container is not empty and operates correctly .

C - Check that the jets of the washing and pre-rinsing arms are not clogged. If necessary, clean them.

D - Check that the dishes are placed in the respective racks. Soup plates have to be mandatorily placed in rack type P12-16.

E - Check that the temperatures in the tanks are the specified ones.

F - One or several pumps don't operate, in this case check that:

- the overload cutuot didn't switch the pump in question and, if necessary,restore it (this drawback is displayed by lamp M (LS3) being ON)

- the coil of the respective remote switch are not broken

- finally, the pump is not blocked, the motor is effective and rotates in the right direction.

PUMPS ELECTRICAL COMPONENTS

1st wash

PUMP	M02
CONTACTOR	MT5
CUTOUT	RM2

H - Shadings or spots present on dishes, specially on glasses, may be caused by minerals present in the water. In such an event, it is suggested to analyze the water used. The contents of calcium and magnesium in the water should not exceed 10°F. The presence of iron should not exceed 0,1 ppm. If these values are exceed, it is suggested to treat the water as appropriate .

I - A preliminary softening is suggested prior to washing knives, forks and spoons

9 - Temperatures insufficient in one or several tanks

- A - Check that the thermostats are effective and calibrated .
- B - Check that the temperature of the feeding water is from 50° to 60° C, as specified .
- C - Check that the thermostats relevant to the tanks are set to the right temperatures and operate correctly .
- D - Check that the fuses and the coil of the remote switch are not broken .
- E - Check that the heater elements are effective .

HEATER ELECTRICAL COMPONENTS

	1st wash
TEMPERATURE	50°-60°C
HEATERS	R2
THERMOSTATS	CT3
CONTACTORS	MT2

10 - Rinsing insufficient

An effective rinsing also depends on correct washing operations . Therefore, prior to checking the rinsing system, make sure that washing took place correctly, and specifically look at item X in the respective paragraph. Having ascertained that washing was made correctly, check that :

- A - The dynamic pressure of the feeding water is not less than 2 bars. Should the pressure be insufficient, install rinse buster pump M07 in order to increase pressure .
- B - The nozzles are not clogged by calcareous residuals and they are oriented to the right direction .
- C - Water inlet solenoid valve EV1 operates correctly.
- D - The water input filter is not clogged
- E - Energy-saver microswitch FCE1 and FCP9 are effective .
- F - The curtain of the last tank is in the right position and does not cover the rinsing nozzles when dishes pass there .
- G - The boiler is not scaled to such an extent as to limit the water flow rate.

11 - Insufficient Rinsing temperature

The temperature of the rinsing water should range from 80° to 90° C.

Should it be lower, check that :

- A - The thermometer is effective and calibrated .
- B - The temperature of the feeding water ranges from 50° to 60° C specified (excluding machines with drain heat recovery unit) .
- C - The dynamic pressure of the feeding water does not exceed 2 bars. If so, calibrate the pressure reducer incorporated in the machine.
- D - The rinsing nozzles have not been unduly widened or replaced.

E - The thermostats relevant to boiler CT2 is set to the right temperature and operate correctly.

If the drawback is not due to any of the causes listed hereabove, proceed as follows :

for machines with electric heating

- check that the coil of remote switch MT03 is not broken
- check all elements of boiler heaters R1
- check the security thermostat CT1 is on

for machines with steam heating

- check that the steam inlet gate is open and it is present with a pressure not less than 0,5 bars,
- check that the filter of the condensated steam drainage is not clogged;
- check that steam solenoid valve EV7 operates correctly,
- check that the input steam filter is not clogged to such an extent as to prevent the normal flow rate,
- check that the condensated steam outlet pipe can freely drain by drop,
- check that the pipe-coil of the boiler is not scaled to such an extent as to limit the heat exchange thereof .

12 - Insufficient drying

An effective drying is strictly related to an effective washing and rinsing. Prior to checking the drying system, check whether washing and rinsing have been made correctly. Then check that :

A - The rinse agent liquid container is not empty and the respective proportioner operates correctly.

B - The air suction holes located on the upper panel are not clogged by foreign bodies.

C – The Overload cutout is not triggered. If so, restore it. This drawback is displayed by lamp M (LS3) being ON.

D - Fuses and remote switch coil MT09 are not broken.

E - Motor M05 is not blocked and rotates in the right direction.

F - Using a maximum thermometer, check that the temperature of the hot air jet is at least 80° C. Should it be lower, proceed as follows :

for machines with electrical heating

- check that thermostat CT6 is set to the right position and operates correctly.
- check that fuses and remote switch coil MT07 are effective.
- check that heater element R3 are effective.

for machines with steam heating

- check that the steam inlet gate is open and is present with a pressure not less than 0,5 bars,
- check that the filter of the condensated steam drainage is not clogged;
- check that steam solenoid valve EV7 operates correctly,

- check that the input steam filter is not clogged to such an extent as to prevent the normal flow rate,
- check that the condensated steam outlet pipe can freely drain by drop.

12 - Insufficient aspiration and steam condensation

- A - Check whether foreign bodies obstruct the upper air exhaust hole .
- B - Check that the filter of the condenser battery is not clogged by fat residuals. In such an event, wash it with boiling water and detergent. Rinse thoroughly.
- C - Check that overload cutout is not triggered. If so, restore it. This drawback is displayed by lamp M(LS3) being ON .
- D - Check that fuses and remote switch coil MT16 are not broken.
- E - Check that motor M08 is not blocked nor burnt and rotates in the right direction
- F - Check that the cold water feed cock is open and water is present at a pressure of at least 2 bars.
- G - Check that cold water inlet filter D is not clogged to such an extent as to limit the flow rate.

The manufacturer declines any responsibility for any misprints contained in this booklet. The Manufacturer also reserves the right to make any modifications to its products that don't affect the basic characteristics thereof.

ATTENTION !



ENGLISH

FOR A CORRECT WORKING OF THE MACHINE (PUMPS, FANS, ETC.), PLEASE CHECK THAT THE **PULL-THROUGH CRANK** INSIDE THE MACHINE (FIG."A") TURNS ANTICLOCKWISE, OR THAT THE **DRIVE MOTOR** SHAFT UNDER THE WASHING TANK (FIG."B") TURNS IN THE DIRECTION INDICATED BY THE YELLOW ARROW ON THE MOTOR BODY.

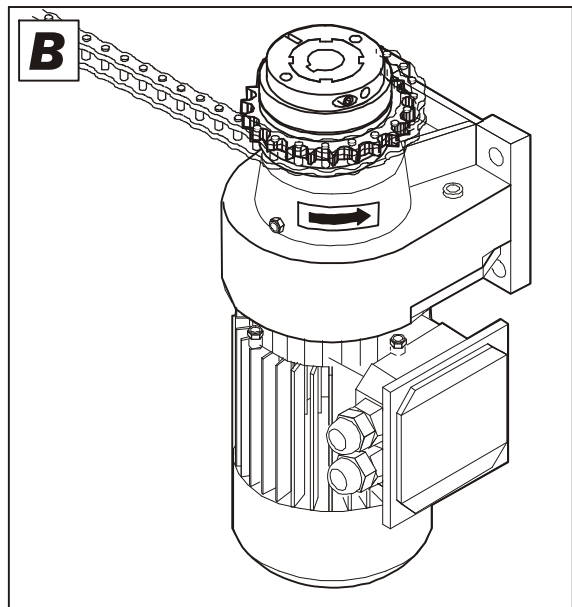
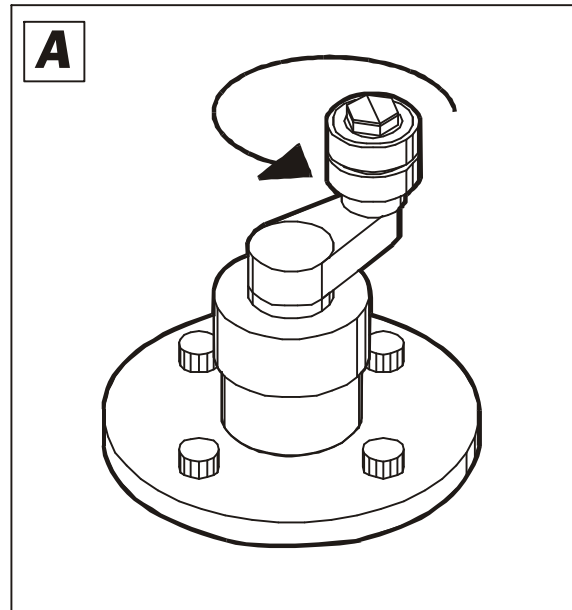

ETI-MANOV-TRAINO

TABLE CONNECTION SCHEME

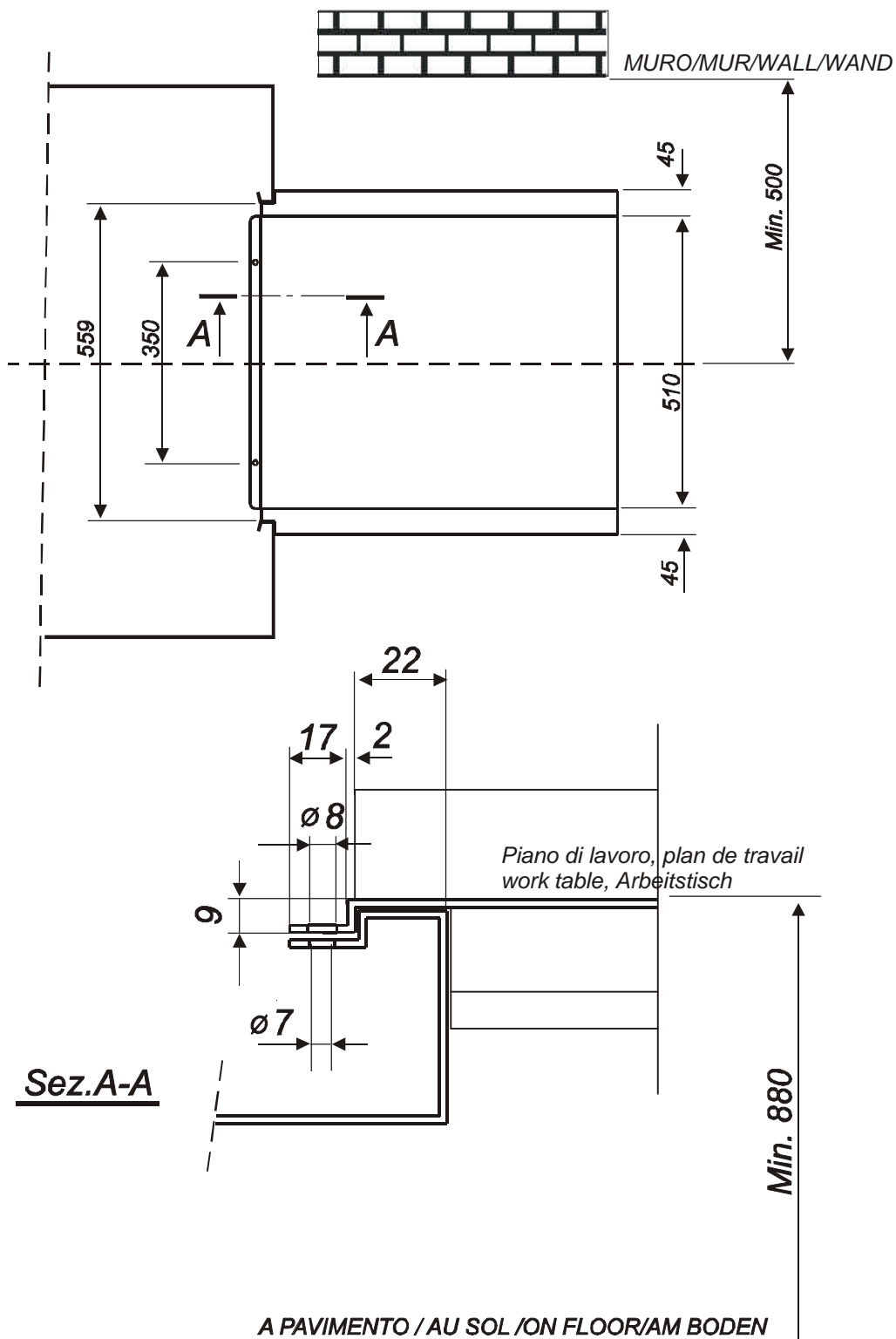

WIRING DIAGRAM KEY

ABBR.	COMPONENT
AD1	ANTI-JAMMING FILTER
BS1	BOILER SAFETY AUTOMATIC SWITCH RELEASE COIL
BS2	DRYING SAFETY AUTOMATIC SWITCH RELEASE COIL
BS3	SAFETY AUTOMATIC SWITCH RELEASE COIL FOR ADDITIONAL BOILER
BS4	SAFETY AUTOMATIC SWITCH RELEASE COIL FOR ADDITIONAL DRYING UNIT
CP1	LOWER PRESSURE SWITCH FOR MAIN WASHING
CP2	UPPER PRESSURE SWITCH FOR MAIN WASHING
CP3	PRE-WASH PRESSURE SWITCH
CP4	PRESSURE SWITCH FOR SECOND WASHING
CP5	PRE-RINSE PRESSURE SWITCH
CP6	PRESSURE SWITCH FOR SECOND PRE-WASHING
CP7	PRESSURE SWITCH FOR THIRD WASHING
CP8	PRESSURE SWITCH FOR RECYCLE PUMP
CP9	PRESSURE SWITCH FOR PRE-WASHING DRAIN
CP10	PRESSURE SWITCH FOR WASHING DRAIN
CT01	BOILER SAFETY THERMOSTAT
CT02	BOILER THERMOSTAT
CT03	THERMOSTAT FOR MAIN WASH TANK
CT04	MAXIMUM TEMPERATURE THERMOSTAT FOR PRE-WASH TANK
CT05	DRYING SAFETY THERMOSTAT
CT06	DRYING THERMOSTAT
CT07	THERMOSTAT FOR PRE-RINSE TANK
CT08	THERMOSTAT FOR SECOND WASH TANK
CT09	THERMOSTAT FOR PRE-WASH TANK HEATING
CT10	SAFETY THERMOSTAT FOR ADDITIONAL BOILER
CT11	THERMOSTAT FOR ADDITIONAL BOILER
CT12	THERMOSTAT FOR HEAT RECOVERER
CT13	THERMOSTAT FOR SECOND PRE-WASH HEATING
CT14	THERMOSTAT FOR THIRD WASHING
CT15	SAFETY THERMOSTAT FOR ADDITIONAL DRYING
CT16	THERMOSTAT FOR ADDITIONAL DRYING
CT17	DRYING STOP THERMOSTAT
CT18	ECONOMY THERMOSTAT
EV01	LOADING SOLENOID VALVE
EV02	RINSE SOLENOID VALVE
EV03	PREWASH COOLING SOLENOID VALVE
EV04	STEAM CONDENSER SOLENOID VALVE
EV05	HEAT RECOVERER ENTRY SOLENOID VALVE
EV06	HEAT RECOVERER EXIT SOLENOID VALVE
EV07	BOILER STEAM SOLENOID VALVE
EV08	STEAM SOLENOID VALVE - HEATED WATER IN THE MAIN WASH TANK
EV09	DRYING STEAM SOLENOID VALVE
EV10	STEAM SOLENOID VALVE - HEATED WATER IN THE SECOND WASH TANK
EV11	COLD PREWASH SOLENOID VALVE
EV12	STEAM SOLENOID VALVE - HEATED WATER IN THE MAIN PRE-WASH TANK
EV13	GAS-FIRED BOILER ENTRY SOLENOID VALVE (FROM RCL)/RECOVERER EXIT SOLENOID VALVE
EV14-16	SELF-WASHING AREAS SOLENOID VALVES
EV17	SELF-WASHING SYSTEM SOLENOID VALVE
EV18	TANK DRAIN SOLENOID VALVE
EV19	HEAT PUMP SOLENOID VALVE
EV11	PRE-WASHING LOADING SOLENOID VALVE
FC1	LIMIT SWITCH FOR EXIT TABLE

FC2	LIMIT SWITCH FOR BASKET UNLOADING
FC3	SAFETY LIMIT SWITCH FOR BASKET UNLOAD CHAIN
FC4	SAFETY LIMIT SWITCH TOP 1 UNLOAD CHAIN
FC5	SAFETY LIMIT SWITCH
FCE1	RINSING ECONOMIZER
FCE2	PRE-RINSE ECONOMIZER
FCE3	WASHING ECONOMIZER (SELF-TIMING)
FCE4	MICROSWITCH FOR BUSY CORNER PREWASH AREA
FCE5	MICROSWITCH FOR BUSY LOADING ENTER AREA
FCE6	COLD PREWASH ECONOMIZER
FCECL1	MAIN WASH DRAIN OPENING CONTROL
FCECL2	PRE-WASH DRAIN OPENING CONTROL
FCECL3	SECOND WASH DRAIN OPENING CONTROL
FCL1	PHOTOELECTRIC CELL FOR CORNER UNLOADING SYNCHRONISM
FCL2	PHOTOELECTRIC CELL 1 CORNER UNLOADING
FCL3	PHOTOELECTRIC CELL 2 CORNER UNLOADING
FCL4	PHOTOELECTRIC CELL FOR LINEAR SELF-TIMER EMITTER
FCL4A	PHOTOELECTRIC CELL FOR LINEAR SELF-TIMER RECEIVER
FCP01/0	MAIN WASHING DOOR LIMIT SWITCH
FCP02/0	PRE-WASH DOOR LIMIT SWITCH
FCP03/0	PRE-RINSE DOOR LIMIT SWITCH
FCP04/0	SECOND WASHING DOOR LIMIT SWITCH
FCP05/0	CORNER DRYING UNIT AND RCL DOOR LIMIT SWITCH
FCP06/0	DOOR LIMIT SWITCH FOR ENTRY LINEAR BELT
FCP07/0	DOOR LIMIT SWITCH FOR EXIT LINEAR BELT
FCP08/0	SECOND PRE-WASH DOOR LIMIT SWITCH
FCP09/0	DOOR LIMIT SWITCH FOR TANK LOADING M115
FCP10/1	THIRD WASHING DOOR LIMIT SWITCH
FCP11/11A	DOOR LIMIT SWITCH FOR ADDITIONAL DRYING TUNNEL
FCP12/1	DOOR LIMIT SWITCH FOR PREWASH-WASH NEUTRAL INTERMEDIATE
FCP13/1	DOOR LIMIT SWITCH FOR WASH-RINSE NEUTRAL INTERMEDIATE
FCP14/1	DOOR LIMIT SWITCH FOR LINEAR ENTRY TABLE FILTER
FCSC1	PREWASH DRAIN MICROSWITCH
FCSC2	MAIN WASHING DRAIN MICROSWITCH
FLS1	RINSE FLOWMETER
FS1-2-3	MAIN SWITCH FUSES
FS4	PRIMARY TRANSFORMER FUSES FOR DETERGENT PUMP
FS5	PRIMARY TRANSFORMER FUSES FOR RINSE AID PUMP
FS6	FUSES FOR DETERGENT PUMP
FS7	FUSES FOR RINSE AID PUMP
FS8	PRIMARY TRANSFORMER FUSES FOR TEMPERATURE RECORDER
IA01	AUTOMATIC SWITCH PRIMARY TRANSFORMER
IA02	AUTOMATIC SWITCH SECONDARY TRANSFORMER
IA03	AUTOMATIC SWITCH FOR BOILER HEATING ELEMENT
IA04	AUTOMATIC SWITCH FOR MAIN TANK ELEMENT
IA05	AUTOMATIC SWITCH FOR PRIMARY TRANSFORMER FOR DOORS
IA06	AUTOMATIC SWITCH FOR SECONDARY TRANSFORMER FOR DOORS B191
IA07	AUTOMATIC SWITCH FOR DRYING HEATING ELEMENT
IA08	AUTOMATIC SWITCH FOR PRE-RINSE HEATING ELEMENT
IA09	AUTOMATIC SWITCH FOR SECOND TANK HEATING ELEMENT
IA10	AUTOMATIC SWITCH FOR PREWASH HEATING ELEMENT
IA11	AUTOMATIC SWITCH FOR ADDITIONAL BOILER HEATING ELEMENT
IA12	AUTOMATIC SWITCH FOR SECOND PREWASH HEATING ELEMENT

IA13	AUTOMATIC SWITCH FOR THIRD TANK HEATING ELEMENT
IA14	AUTOMATIC SWITCH FOR ADDITIONAL DRYING HEATING ELEMENT
IN0	MACHINE GENERAL ISOLATOR WITH FUSES
IN1	MACHINE START SWITCH 0-1-2
IN2	PRE-RINSE SWITCH
IN3	DRYING SWITCH 9KW
IN4	SELF-TIMER SWITCH
IN5	ADDITIONAL DRYING UNIT SWITCH
IN6	INVERTER SWITCH
LIV1	DETERGENT LEVEL
LIV2	RINSE AID LEVEL
LS1	TURN-ON LAMP
LS2	TANK LEVEL LAMP
LS3	OVERLOAD CUTOFF LAMP
LS4	LAMP FOR FREE CORNER PRE-WASH AREA
LS5	EMERGENCY LAMP FOR RINSING FLOWMETER
LS6	SELF-WASHING SYSTEM CYCLE LAMP
LS7	AUTOTIMER LAMP
LS8	START LAMP
LS9	DETERGENT LEVEL ALARM LAMP
LS10	DRAIN LAMP
M01	TOWING GEARED MOTOR V1
M01A	TOWING GEARED MOTOR V2
M02	MAIN WASH PUMP
M03	PRE-WASH PUMP
M04	FAN MOTOR
M05	MOTOR FAN FOR DRYING UNIT
M06	RINSE PUMP
M07	BOOSTER PUMP
M08	STEAM CONDENSER FAN MOTOR
M09	SECOND WASH PUMP
M10	HEAT RECOVERER FAN MOTOR
M11	GEARED MOTOR FOR MOTORIZED CURVE V1
M11A	GEARED MOTOR FOR MOTORIZED CURVE V2
M12	SECOND PRE-WASH PUMP
M13	GEARED MOTOR FOR RACK UNLOAD TABLE
M14	THIRD WASH PUMP
M15	RECYCLE PUMP
M16	ADDITIONAL MOTOR FAN FOR DRYING UNIT
M17	MACHINE SELF-WASHING PUMP
M18	DRAIN PUMP
M19	HEAT PUMP COMPRESSOR
MT01	LEVEL CONTROL CONTACTOR
MT02	HEATING ELEMENT CONTACTOR FOR MAIN WASH TANK
MT03	BOILER HEATING ELEMENT CONTACTOR
MT04	CONTACTOR FOR TOWING MOTOR
MT04A	CONTACTOR FOR TOWING MOTOR (SECOND SPEED)
MT04B	CONTACTOR FOR TOWING MOTOR (THIRD SPEED)
MT05	CONTACTOR FOR MAIN WASH PUMP
MT06	CONTACTOR FOR PRE-WASH PUMP
MT07	CONTACTOR FOR FAN MOTOR
MT08	CONTACTOR FOR HEATING ELEMENT OF DRYING UNIT
MT09	CONTACTOR FOR DRYING UNIT MOTOR FAN
MT10	CONTACTOR FOR PRE-RINSE PUMP
MT11	CONTACTOR FOR PRE-RINSE HEATING ELEMENT
MT12	CONTACTOR FOR DOOR MAGNETIC SWITCH (MATIC M39-49-59/LINEAR)

MT13	CONTACTOR-RELAY FOR RINSE ECONOMIZER (MATIC BOOSTER PUMP)
MT14	BOOSTER PUMP CONTACTOR
MT15	SECOND WASH PUMP CONTACTOR
MT16	CONTACTOR FOR STEAM CONDENSER FAN MOTOR
MT17	CONTACTOR FOR SECOND WASH TANK ELEMENT
MT18	CONTACTOR FOR HEAT RECOVERER FAN MOTOR
MT19	CONTACTOR FOR ADDITIONAL BOILER
MT20	CONTACTOR FOR MOTOR V1 MOTORIZED CURVE
MT20A	CONTACTOR FOR MOTOR V2 MOTORIZED CURVE
MT21	CONTACTOR FOR PRE-WASH HEATING ELEMENT
MT22	CONTACTOR FOR LINEAR RINSE ECONOMIZER
MT23	CONTACTOR-RELAY FOR PHOTOELECTRIC CELL 1 BASKET UNLOADER
MT24	CONTACTOR-RELAY FOR PHOTOELECTRIC CELL 2 BASKET UNLOADER
MT25	CONTACTOR-RELAY FOR SYNCHRONISM PHOTOELECTRIC CELL (BASKET UNLOADER)
MT26	CONTACTOR FOR BASKET UNLOADER GEARED MOTOR
MT27	RINSE CONTACTOR
MT28	CONTACTOR FOR BASKET UNLOADER START
MT29	SECOND PRE-WASH PUMP CONTACTOR
MT30	SECOND PRE-WASH HEATING ELEMENT CONTACTOR
MT31	CONTACTOR FOR THIRD WASH PUMP (LINEAR 80)
MT32	CONTACTOR FOR THIRD WASH HEATING ELEMENT
MT33	CONTACTOR FOR RECYCLE PUMP
MT34	CONTACTOR FOR ADDITIONAL DRYING UNIT ELEMENT
MT35	CONTACTOR FOR ADDITIONAL DRYING UNIT MOTOR FAN
MT36	CONTACTOR FOR COUPLING OF AUTOTIMER-COLD PREWASH
MT37	CONTACTOR FOR LINEAR AUTOTIMER CONVEYOR
MT38	CONTACTOR FOR LINEAR AUTOTIMER PHOTOELECTRIC CELLS
MT39	AUTOWASHING PUMP CONTACTOR
MT40	START CONTACTOR FOR INDEPENDENT DRYING TUNNEL
MT41	DETERGENT PUMP LEVEL CONTACTOR
MT42	RINSE AID PUMP LEVEL CONTACTOR
MT43	RINSING FLOWMETER CONTACTOR
MT44	DRAIN PUMP CONTACTOR
MT45	AUTOTIMER START CONTACTOR
MT46	CONTACTOR FOR HEAT PUMP COMPRESSOR
MT47	RELAY FOR HEAT PUMP LEVELS
PS01	START PUSHBUTTON
PS02	STOP PUSHBUTTON
PS03	EMERGENCY PUSHBUTTON
PS04	LOADING TABLE EMERGENCY PUSHBUTTON
PS05	UNLOADING TABLE EMERGENCY PUSHBUTTON
PS06	RACK UNLOADER EMERGENCY PUSHBUTTON
PS07	ENTRY TABLE START PUSHBUTTON
PS08	EXIT TABLE START PUSHBUTTON
PS09	ENTRY TABLE STOP PUSHBUTTON
PS10	EXIT TABLE STOP PUSHBUTTON
PS11	LINEAR CONVEYOR START PUSHBUTTON WITH AUTOTIMER
PS12	SELF-WASH CYCLE START PUSHBUTTON
PS13	DRAIN PUSHBUTTON
R01	BOILER HEATING ELEMENT
R02	MAIN WASH HEATING ELEMENT
R03	DRYING UNIT HEATING ELEMENT
R04	PRE-RINSE HEATING ELEMENT
R05	SECOND WASH HEATING ELEMENT
R06	PRE-WASH HEATING ELEMENT
R07	ADDITIONAL BOILER HEATING ELEMENT

R08	SECOND PRE-WASH HEATING ELEMENT
R09	THIRD WASH HEATING ELEMENT
R10	ADDITIONAL DRYING UNIT HEATING ELEMENT
RM01	AUTOMATIC THERMIC RELAY FOR TOWING MOTOR V1
RM01A	AUTOMATIC THERMIC RELAY FOR TOWING MOTOR V2
RM02	AUTOMATIC THERMIC RELAY FOR MAIN WASH PUMP
RM03	AUTOMATIC THERMIC RELAY FOR PRE-WASH PUMP
RM04	AUTOMATIC THERMIC RELAY FOR FAN MOTOR
RM05	AUTOMATIC THERMIC RELAY FOR DRYING UNIT FAN MOTOR
RM06	AUTOMATIC THERMIC RELAY FOR PRE-RINSE PUMP
RM07	AUTOMATIC THERMIC RELAY FOR BOOSTER PUMP
RM08	AUTOMATIC THERMIC RELAY FOR STEAM CONDENSER MOTOR FAN
RM09	AUTOMATIC THERMIC RELAY FOR SECOND WASH PUMP
RM10	AUTOMATIC THERMIC RELAY FOR HEAT RECOVERER MOTOR FAN
RM11	AUTOMATIC THERMIC RELAY FOR MOTOR V1 (MOTORIZED CURVE)
RM11A	AUTOMATIC THERMIC RELAY FOR MOTOR V1 (MOTORIZED CURVE)
RM12	AUTOMATIC THERMIC RELAY FOR MOTOR V2 (MOTORIZED CURVE)
RM13	AUTOMATIC THERMIC RELAY FOR SECOND PRE-WASH PUMP
RM14	AUTOMATIC THERMIC RELAY FOR THIRD WASH PUMP
RM15	THERMIC RELAY FOR RECYCLE PUMP
RM16	THERMIC RELAY FOR ADDITIONAL DRYING UNIT MOTOR FAN
RM17	THERMIC RELAY FOR SELF-WASH PUMP
RM18	THERMIC RELAY FOR DRAIN PUMP
RM19	THERMIC RELAY FOR HEAT PUMP
S1	SIREN FOR LINEAR CONVEYOR BELT START
SL1	SPEED SELECTOR 1-0-2
SL2/2A	MACHINE SELF-WASHING SYSTEM SELECTOR
T1	THERMOMETER FOR WATER INLET
T2	THERMOMETER FOR PRE-WASH CYCLE
T3	THERMOMETER FOR MAIN WASH CYCLE
T4	THERMOMETER FOR RINSING CYCLE
T5	THERMOMETER FOR SECOND WASH CYCLE
T6	THERMOMETER FOR DRYING UNIT
T7	THERMOMETER FOR THIRD WASH CYCLE
TM1	TIMER FOR LINEAR CONVEYOR BELT START
TM2	AUTOTIMER
TM3	TIMER FOR AUTOTIMER START
TM4	TIMER FOR LINEAR RINSE ECONOMIZER
TM5	TIMER FOR SELF-WASHING SYSTEM
TM6	TIMER FOR DRAIN
TR01	TRANSFORMER
TR02	TRANSFORMER FOR RINSE AID PUMP SYSTEM
TR03	TRANSFORMER FOR DOOR SYSTEM
TR04	TRANSFORMER FOR WATER INLET THERMOMETER
TR05	TRANSFORMER FOR PRE-WASH THERMOMETER
TR06	TRANSFORMER FOR MAIN WASH THERMOMETER
TR07	TRANSFORMER FOR RINSE THERMOMETER
TR08	TRANSFORMER FOR SECOND WASH THERMOMETER
TR09	TRANSFORMER FOR DRYING UNIT THERMOMETER
TR10	TRANSFORMER FOR TEMPERATURE RECORDER