

PULSATrol™

MICROPROCESSOR-BASED WATER
TREATMENT CONTROLLER

MCT100 SERIES

MODELS MCT110, MCT120 & MCT130

INSTALLATION
OPERATION
MAINTENANCE
INSTRUCTION

PULSATROL FACTORY SERVICE POLICY

Your PULSATrol controller is a state of the art microprocessor based unit with on-board diagnostics. If you are experiencing a problem with your PULSATrol controller, first consult the troubleshooting guide in your operation and maintenance manual. If the problem is not covered or cannot be solved, please contact our Technical Services Department for further assistance.

Trained technicians are available to diagnose your problem and arrange a solution. Solutions may include purchase of replacement parts or returning unit to the factory for inspection and repair. All returns require a Return Authorization number to be issued by Pulsafeeder Electronic Control Operations (ECO). Parts purchased to correct a warranty issue may be credited after an examination of original parts by Pulsafeeder ECO. Warranty parts returned as defective which test good will be sent back freight collect. No credit will be issued on any replacement electronic parts.

Any modifications or out-of-warranty repairs will be subject to bench fees and costs associated with replacement parts.

PULSATROL WARRANTY

Pulsafeeder, Inc. warrants PULSATrol control systems of its manufacture to be free of defects in material or workmanship. Liability under this policy extends for 24 months from date of shipment. The manufacturer's liability is limited to repair or replacement of any failed equipment or part which is proven defective in material or workmanship upon manufacturer's examination. This warranty does not include removal or installation costs and in no event shall the manufacturer's liability exceed the selling price of such equipment or part.

The manufacturer disclaims all liability for damage to its products through improper installation, maintenance, use, or attempts to operate such products beyond their functional capacity, intentionally or otherwise, or any unauthorized repair. The manufacturer is not responsible for consequential or other damages, injuries, or expense incurred through the use of its products.

The above warranty is in lieu of any other warranty, whether expressed or implied. The manufacturer makes no warranty of fitness or merchantability. No agent of ours is authorized to provide any warranty other than the above.

Note: pH probes are not covered under the PULSATrol warranty. These items carry their own manufacturer's warranty.

FCC WARNING

This equipment generates and uses radio frequency energy. If not installed and used properly, in strict accordance with the manufacturer's instructions it may cause interference to radio communications. It has been type tested and found to comply with the limits for a class A computing device pursuant to subpart J of part 15 of FCC Rules, which are designed to provide reasonable protection against such interference when operated in a commercial or industrial environment. Operation of this equipment in a residential area is likely to cause interference in which case the user, at his own expense, will be required to take whatever measures necessary to correct the interference.

1.	Introduction.....	4
a.	Product Description	4
2.	Installation	5
a.	Installation notes.....	6
b.	Electrode/probe installation	7
c.	Accessories	8
d.	Electrical wiring.....	9
3.	Start-up instructions.....	10
a.	Initialization.....	10
b.	Front panel	11
c.	Menu structure.....	11
d.	Keypad operation	12
e.	Sample programming	13
4.	MCT100 Series Controller Set-up.....	14
a.	General Information	15
b.	System Configure	15
i.	Date, Time, Day, Week.....	15
ii.	Hi Lo Alarm.....	16
iii.	Control Set Point	16
iv.	View Software Version	16
v.	Set Sensitivity	17
vi.	Selectable Inhibitor Feed Timer (mode selection).....	17
vii.	Analog Output Settings	17
viii.	Scale/Range	18
c.	Selectable Inhibitor Feed Timer.....	18
d.	Biocide Programs	20
e.	Set Points and Alarms	22
i.	Rising or Falling Set Point	22
ii.	High or Low Alarm Settings	23
iii.	Set Point Differential	23
iv.	Limit Timer	24
5.	System Calibration	24
a.	Conductivity Calibration (MCT110).....	25
b.	pH Calibration (MCT120).....	25
c.	ORP Calibration (MCT130).....	27
6.	Analog Output Calibration.....	29
7.	Diagrams: Installation, Component, and Electrical	29
8.	Specifications	38
9.	Factory Default Values	39
10.	Troubleshooting	40
11.	Maintenance	42
12.	Glossary.....	44
13.	Index	48
14.	Other Models in MCT Series w/Options.....	48
15.	Biocide Programming Worksheet.....	50

1. Introduction

The PULSAtrol™ Series of microprocessor based controllers have been designed to control and monitor a wide range of parameters, both analog and digital.

This instruction manual covers the MCT100 Series of PULSAtrol™ controllers. Refer to Table 1 for the specific standard features and options for the model number of your controller. All standard features are covered in this manual and most options have instructions where applicable.

IMPORTANT! While using this manual, if you see instructions for a feature that does not display on your controller, check the following:

- Consult Table 1 to see if that feature is available for your controller either as standard or option.
- Refer to the model number of your controller found on the enclosure of the unit. The letters after the model number are the options installed (i.e. MCT110 ABC).
- After the above steps, if feature does not display, reinitialize the unit. If that fails, consult the factory.

For your convenience, there is an abbreviated instruction and software MENU MAP laminated card supplied with all manuals to be kept with the controller. This card is not a substitute for this instruction manual. It is supplied as a quick reference only and should be used in conjunction with the instruction manual.

a. Product Description

The MCT110 controllers are designed to monitor and control Total Dissolved Solids (TDS) in open recirculating cooling systems, in terms of electrical conductivity measured in micro Siemens (S/cm). A set point of the desired conductivity limit is entered into the controller through the front keypad. As this maximum limit is exceeded, a blowdown valve is opened. The system water with higher levels of TDS is blown down resulting in fresh make-up water being added, reducing the concentration of TDS in the cooling system.

The MCT120 controllers monitor and control pH by adding acid (or caustic) based on a set point entered into the controller through the front keypad. The set point has a built in limit timer that acts as a fail safe to prevent system overfeed.

The MCT130 controllers monitor and control ORP by adding disinfectant based on a set point entered into the controller through the front keypad. The set point has a built in limit timer that acts as a fail safe to prevent system overfeed.

The design also includes a High/Low conductivity/pH/ORP Alarm with relay output. The alarms can be operated in one of two modes: Track Set Point, in which an alarm offset is entered and the alarms automatically adjust themselves around the set point or Independently Set, which allows you to independently set both the High and Low Alarms.

The design may also incorporate a Selectable Inhibitor Feed Timer (Option C) which allows the user to choose 1 of 4 timer modes on which to base the addition of inhibitor.

- **LIMIT TIMER** The Inhibitor Timer is actuated simultaneously with blowdown. The timer limits feed time during any single blowdown cycle, preventing overfeed.

- **PERCENT TIMER** The Inhibitor Timer runs continuously for an adjustable time cycle, with output being activated for an adjustable percent of the time cycle.
- **PERCENT POST BLOWDOWN** This mode keeps track of the total blowdown time and activates the Inhibitor Timer when the blowdown deactivates, for a percent of total blowdown time set.
- **PULSE TIMER** The controller accepts pulses from a contact head water meter located in the make-up line and/or blowdown line of the cooling system, to activate the Inhibitor Timer for an adjustable amount of time based on the amount of pulses received.

A mounted flow assembly with quick release electrode, flow switch and sample cock is provided with option "B" selection for the ease and convenience of installation and to facilitate periodic maintenance and sampling. The flow switch disables the outputs of the controller when flow is discontinued in the flow assembly.

A battery back-up is used to maintain time and history for up to two weeks on power loss. The EEPROM protects operating parameters during power outages. Hand/Off/Auto keys are provided on the keypad for immediate control of pumps, solenoid valves, etc., without scrolling through menus.

The MCT100 Series also allows the user to choose a rising or falling set point. The controller accepts options such as biocide timers, and/or communications.

Standard Features		
<i>MCT110</i>	<i>MCT120</i>	<i>MCT130</i>
Conductivity	pH Control	ORP Control
High/Low Alarm	High/Low Alarm	High/Low Alarm
	Limit Timer	Limit Timer
Optional Features		
<i>MCT110</i>	<i>MCT120</i>	<i>MCT130</i>
A – Conduit	A – Conduit	A – Conduit
B – Flow Assembly	B – Flow Assembly	B – Flow Assembly
C – Selectable Timer	E - Biocide	E - Biocide
E - Biocide	K – Dry Alarm Contact	K – Dry Alarm Contact
K – Dry Alarm Contact	N – Remote Transmitter	N – Remote Transmitter
M3 –4-20MA	M3 – 4-20MA	M3 – 4-20MA
N – Remote Transmitter	P – 220VAC 50/60Hz Requires Option A	P – 220VAC 50/60Hz Requires Option A
P – 220VAC 50/60Hz Requires Option A		

2. Installation

!!WARNING!!

CONTROLLER COULD BE DAMAGED AND VOID WARRANTY!

Avoid locations where the controller would be subjected to extreme cold or heat (less than 0oF(-17.8oC) or greater than 122oF(50oC)), direct sunlight, vibration, vapors, liquid spills

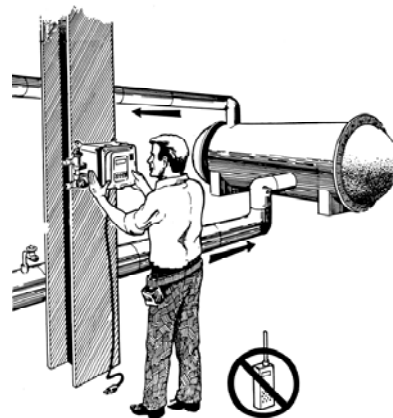

or EMI (electromagnetic interference; i.e., strong radio transmission and electric motors).

a. Location

Select a mounting location convenient to grounded electrical and plumbing connections. Mount the controller on a wall or other vertical surface with adequate lighting. Position so operator has access to the unit and a clear view of front panel display. Refer to Diagram 1, pg. 26, Standard Enclosure Dimensional Data and Mounting Hole Template for mounting details of our standard enclosures. An actual size Mounting Template (Attachment A) is provided for your convenience. Avoid locations where the controller would be subjected to extreme cold or heat [less than 0F (-17.8 C) or greater than 122F (50C)], direct sunlight, vibration, vapors, liquid spills or EMI (electromagnetic interference; i.e., strong radio transmission). Installation should comply with national, state, and local codes.

NOTE: NOT ALL EQUIPMENT SHOWN IS PROVIDED WITH THE CONTROLLER AND IS FOR REFERENCE ONLY.

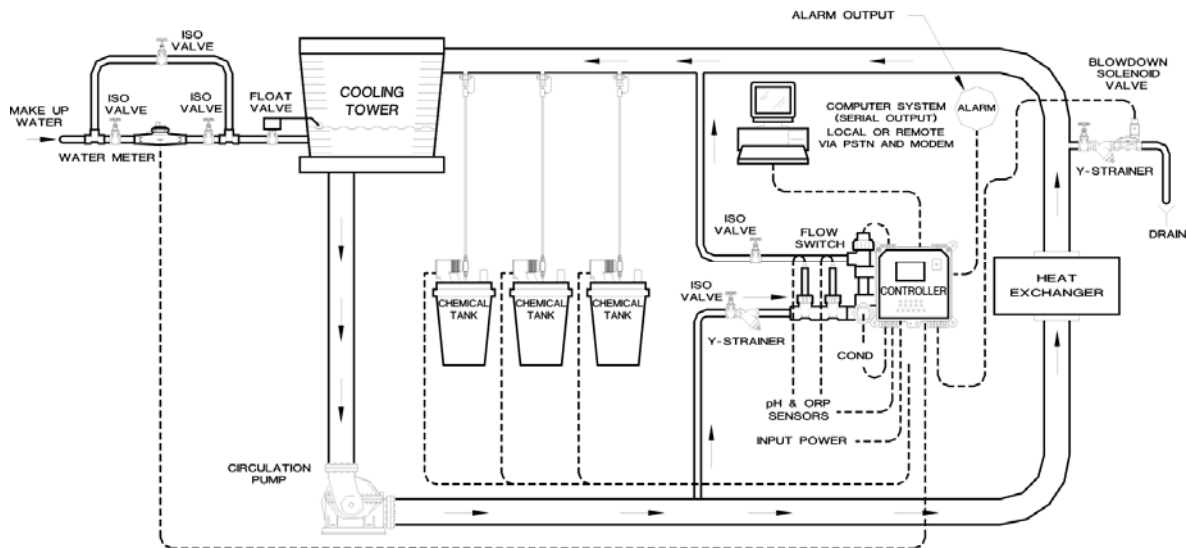

b. Installation Notes

NOTICE

The standard flow assembly, if provided with this controller, is constructed of durable glass filled polypropylene (GFPP). Standard connection to flow line is 3/4 @ NPT. A PVC thread to slip adaptor is provided so that a PVC weld joint, if preferred, can be used.

- Install sensors or sample stream flow assembly at some point before chemical injection points, where chemical and water are thoroughly mixed. Refer to Figure 1.
- Measuring surfaces of the sensor electrodes must be continuously immersed in system water.
- Inlet pressure of the sample flow assembly must have a flow rate of at least 1 USgpm (US gallons per minute) so system water will flow past the sensors.

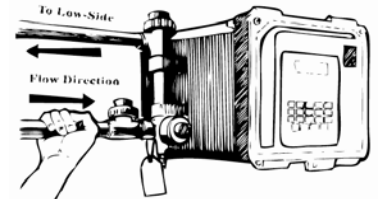

FIGURE 2
 Hand tighten all NPT connections until snug plus 1/2 turn.
 Note that a pressure differential must exist between the High and Low side for proper flow.

- Install hand valves on each side of the flow assembly for easy isolation and removal of sensors and strainer screens (see Fig.1).
- Direction of flow should be from the bottom to the top of the flow assembly (see Fig. 2).
- A manual needle valve should be installed in the blowdown line on the system side of the solenoid valve. This will be used for isolating and throttling (controlling the flow rate of blowdown) blowdown assembly if blowdown is incorporated.
- Most solenoid valves require a pressure differential of 7 to 15 psi to close. If this is not available, install zero pressure solenoid valve, if blowdown is incorporated.
- Always install a strainer upstream of the solenoid valve to collect debris that may clog solenoid valve if blowdown is incorporated.
- For proper operation and accuracy, install water meters horizontally with meter face up if Pulse Timer mode is used.
- If chemicals are to be injected into a sample line (not recommended) always use a back check valve to prevent chemicals from backing up around the sensor.
- If a flow assembly or sample stream assembly is present, never install blowdown valve off these lines. System will not achieve proper blowdown and accuracy of controller readings may be affected.
- Install electrode probes as shown in Figs. 3-7 at right. After installation of probes, open isolation valves to check for leaks.

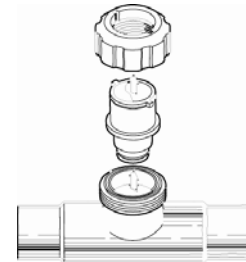

FIGURE 3



FIGURE 4



FIGURE 5

c. Electrode/Probe Installation

WARNING

Care should be exercised when removing the protective rubber boot from the pH electrode. Submerge the tip of the electrode in water to loose the protective boot and remove. Save for future storage. Care should also be taken to prevent the glass bulb from hitting the tee or other piping. Never expose the electrode to air with power on for more than 45 seconds. Never allow the electrode to dry out. Use supplied rubber boot filled with proper storage solution. See Section 10 Maintenance for Sensor.

Controller should be per installation diagram (see Fig. 1). Make sure all fittings and connections are secure:

- Remove power from the controller.
- Close isolation valves located before and after the flow assembly.
- Open the sample port on flow assembly to make sure no flow is present in the flow assembly.



FIGURE 6
IMPORTANT!
Do not allow the probe's tip to dry out.

- Remove coupling ring(s) from probe housings on flow assembly. Then remove threaded insert(s) by gently pulling straight out. Insert is held in place by rubber O ring. (Figure 3).
- Apply six wraps of PTFE tape to threads of probes (Figure 4).
- Slip coupling ring over probe, then hand tighten threaded insert on the PTFE wrapped threads of probe (Figure 5).
- Remove the liquid filled protective rubber boot from the pH probe tip. **IMPORTANT!** Do not allow the probe's tip to dry out, see **WARNING** at left! If supplied, install protective turret on probe tip. (Figure 6).
- Gently install probe into probe housing on flow assembly. Make sure probe is firmly seated in housing. (Figure 7).
- Slip coupling ring down onto housing threads and hand tighten.
- Make sure sample port on flow assembly is closed and apply pressure and flow by opening hand valves slowly to avoid water hammer.



Refer to Diagrams 2 and 3, pages 27-28, for information and specifications for electrodes supplied with your system.

d. Accessories

!!CAUTION!!

Line voltage is present on the power supply located behind the Safety/EMI cover behind the front panel. Line voltage is also present on the relay board located in the bottom of enclosure, even when power is off.

POWER MUST BE DISCONNECTED WHILE CONNECTIONS ARE BEING MADE!

(Available through your Pulsafeeder distributor or sales representative, not included as standard)

- Two manual gate valves, one on each side of the electrode or flow assembly if controller incorporates a flow switch, to isolate the electrode or flow assembly for installation and routine maintenance.
- One needle valve, for isolating and throttling blowdown assembly if controller incorporates a blowdown valve.
- Three manual gate valves, for isolating, by-passing and maintenance of water meter, if controller incorporates a water meter (optional).
- Solenoid valve, if system incorporates blowdown.
- Two Y-strainers, one before solenoid valve and the other before flow assembly.
- Chemical metering pumps as required.
- Contact head water meter, if controller incorporates a pulse timer (optional).

- External alarm, if controller incorporates alarm relay.

e. Electrical Wiring

NOTICE

For proper rejection of AC line voltage spikes, sensor EMI, noise rejection and personal safety, the case ground (SAFETY GROUND) must be properly installed. If ANY doubt, consult a qualified electrician.

The PULSAtrol™ MCT100 Series electronic circuitry is protected by a (Bussman BK/PCE-1) 1 amp fuse (F4). While each output relay is individually protected by replaceable (Bussman BK/PCE-5) plug-in 5 amp fuses (F1, F2, F3) located on the power supply/relay board. Refer to Diagram 4, Power Supply/Relay Board, pg. 29. Use of a surge protector is strongly recommended!

The controller should be connected to its own 15 amp power branch (i.e., its own wiring, circuit breaker, etc.)

Prewired units are supplied with 10 foot, 18 AWG 3 wire grounded power cords and clearly marked 18 AWG 3 wire grounded receptacle cords for all controlled line voltage outputs.

Conduit units are factory predrilled with easily accessible terminals for hard wiring. See Diagram 5, page 30, for input and output power connections. Use only 16 or 18 AWG wire for conduit power and load connections. Never run power and signal wiring (sensor proportional or recorder outputs) together in same conduit. Low voltage signal wiring (i.e., water meter, remote sensors, etc.) should be separate from AC power lines.

NOTE: Liquid tight fittings are provided for all low voltage signal leads.

When connections are required by the end user, follow the instructions below. All electrical diagrams, circuit boards, etc. are located in Section 6, pages 26-33.

OPEN ENCLOSURE

CAUTION!

When power is supplied to the unit, 115 VAC is present on the relay board located in the bottom of the enclosure, even with the power switch off.

!!WARNING!!

CONTROLLER COULD BE DAMAGED AND VOID WARRANTY!

Analog outputs are self powered. Do not try to externally loop power. Externally powered outputs will damage your controller!

Remove the screws from upper control panel and open

FLOW SWITCH OR INTERLOCK

FIGURE 8
*Art for flow switch or
interlock connection.*

It is recommended that a flow switch or auxiliary dry contact from control panel

be used to make outputs inoperative when cooling tower is shut down. This connection is provided for on all units with or without mounted flow assembly. If a flow switch is not ordered with unit, this function will be inoperative. To use the interlock feature, connect a flow switch or auxiliary dry contact from another device (see Figure 8). Refer to Diagram 6, Daughter Board, pg. 31, for flow switch or interlock connection marked JP16 pin 5 and 6. To activate function, turn switch S1-2, Fig. 9 (located on the Mother Board, Diagram 7, pg. 32) on and turn power off, wait 15 seconds and turn back on.

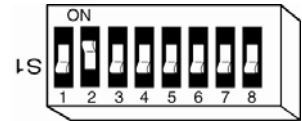

FIGURE 9
Dip switch S1-“2” shown in “on” position to activate interlock function. Art for flow switch or interlock connection.

SENSOR CONNECTIONS

Units supplied with GFPPL flow assemblies (Option B) come from the factory with conductivity or pH or ORP probe pre-connected. Refer to Diagram 6, Daughter Board, pg. 31, for location of sensor connections.

WATER METER (FOR PULSE TIMER)

If a Selectable Inhibitor Feed Mode is present and the Pulse Timer Mode is chosen, connect the water meter on daughter board to connector JP16 pin 7 and 8 (see Fig. 10). Refer to Diagram 6, Daughter Board, pg. 31, for location of these connections.

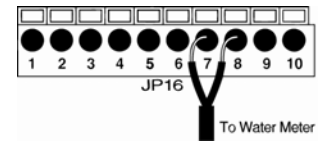

FIGURE 10
Art for water meter connection

ALARM DRY CONTACT

Alarm dry contacts (Rated @ 500 mA) are provided when Option K has been ordered for user connection. Refer to Diagram 4, pg. 29, Power Supply/Relay Board.

RECEPTACLES

The PULSAtrol™ offers a unique prewired package that allows for easy installation. Each cord is clearly marked and readily accessible for connecting external electrical devices to be controlled.

3. Start-up Instructions

NOTE:

The controller must be initialized at start-up to function properly. Also, any extended period of power failure combined with loss of battery power will necessitate reinitializing your controller.

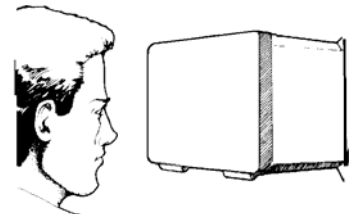

FIGURE 11
Read instructions on cards taped to inside of the plastic cover.

!!WARNING!!

**CONTROLLER COULD BE DAMAGED AND VOID WARRANTY!
UNIT WILL FAIL is initialization procedure is not followed properly.**

READ THE FOLLOWING BEFORE PROCEEDING ANY FURTHER!!

a. Initialization

This unit requires initialization upon start-up (see Figures 11-14 at right). There is a lithium battery backup that protects the time during power outages that must be enabled as follows:

- Before power is supplied, open front panel by loosening the two screws holding the front cover closed with a phillips screwdriver.
- Locate switch S1 on the mother board, Fig. 12 (also refer to Diagram7,pg. 32).Assure switch S1-8 is in the on position.



FIGURE 12
Open front cover. Remove packing material. Locate switch S1.

- With the unit open, locate the battery in the corner of the mother board, behind the front panel. Remove the paper from under the battery clip, Fig. 13.
- With the front panel closed, turn unit on for 15 seconds. After 15 seconds turn unit off, disconnect power, open front panel. Change switch S1-8 to the off position. (Refer to Diagram 7, pg. 32)
- Close front panel. Connect power, turn unit on. The unit is now ready to be configured and programmed, Fig. 14.



FIGURE 13
Remove paper from between battery and clip.

b. Front Panel

Take a moment to review Figure 15, to become familiar with the MCT100 Series controller front panel.



FIGURE 14
Close unit's cover then configure the controller per the user's manual.

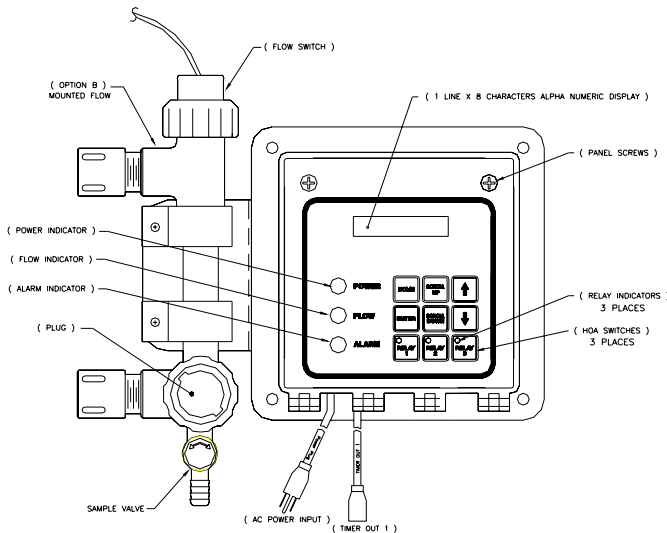

FIGURE 15
MCT110 Front Panel

c. Menu Structure

TIP:

For help with menu locations, please refer to the Menu Map supplied with your controller.

NOTE:

After five minutes of no keypad activity, the controller will display system conductivity (MCT110), system pH (MCT120), or system ORP (MCT130).

The PULSAtrol™ menu structure as well as the hardware were designed with the user in mind. The menu structure or map diagram supplied with the controller was generated to reflect a PULSAtrol™ MCT100 Series controller. The laminated MENU MAP supplied with your controller reflects your system with options.

SYS DATA (System Data) This menu displays system parameters only. No settings or adjustments are made through this menu. Present System Conductivity (MCT110), pH (MCT120) or ORP (MCT130) is displayed along with operating scale and alarms.

SYS CAL (Calibrate Sensor) This menu is for calibration of analog sensors, such as conductivity or pH probes. In this menu, the user is prompted to choose either 2 or 3 point calibration. After a choice is made, the user is prompted to enter value of LO, MID (if 3 point is chosen) and HI calibration solution.

SETPTS (Set Points and Alarms) In this menu, the user is prompted to enter settings pertaining to alarms and set points that control the system operation.

INH FEED (Inhibitor Feed Timer) In this menu, if Option C has been ordered, the user enters the settings pertaining to the inhibitor feed mode chosen in the Configure menu.

BIO A (Biocide Programs) In this menu, if Options E has been ordered, the user is prompted to enter all settings pertaining to the biocide program timer.

CONFIGUR (System Configure) This is generally the first selection made at start up. In this menu, the user is prompted to configure system functions and options to your specific application. System Configure can include such things as time of day, date, rising or falling set point, track set point or independent set of high/low alarm, selection of inhibitor feed mode, analog output, and other installed option(s) configuration.

d. Keypad operation

The Key Pad on the MCT100 series is easy to use and will guide you through all the sub menus and functions of the controller.

Feel free to try out these keys as you read about them. You will not hurt the controller and the values will need to be reprogrammed later anyway.

Home Press this key to return to previously displayed menu

Scroll Up/Scroll Down Some menus contain more choices than can be displayed at once. Press either key to reveal other items on menu displayed. If no other choices are present, nothing will happen when pressing Scroll Keys. The Menu Map supplied with your controller will show you which menus need to be scrolled to show additional choices.

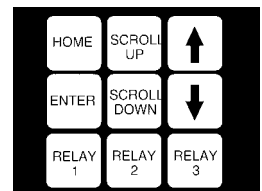
**TIP:**

When using the Arrow Keys, press once to change numbers by one unit. Continuously holding down either Arrow Key will change numbers more rapidly.

Arrows The Arrow Keys are used to change the numerical values associated with the various settings you will be entering. Use “down” arrow to select lower numbers and the “up” arrow to select higher numbers.

Enter This key has two functions:

FIRST, within a sub menu, pressing the Enter Key will activate the selection.

SECOND, after selecting the value needed with the Arrow Keys, press the Enter Key to lock-in the value. The next value to be set (if one exists) that particular sub-menu will be displayed.

Relays (1-3) These Hand/Off/Auto (HOA) keys allow immediate control of pumps, solenoid valves, etc. affected by the controller without scrolling through the menus. Press a Relay Key once to force relay on for 5 minutes (an amber light will appear below that key). Press Relay Key again to force relay off (a red light will appear below that key). Press a Relay Key a third time to return relay to auto control (green light will indicate that relay is on, no light indicates that relay is not activated).

e. Sample programming

IMPORTANT:

NEVER leave a screen with choices still flashing **Controller accuracy may be affected, and/or controller may not operate properly. If you forget, simply return to that menu and complete your programming.**

TIP:

Be sure to press keys firmly until you feel or hear a faint click, then pause before you try again. There is a very slight delay for the controller to react to your command. This is normal.

TIP:

If at any time, while programming your controller, you get lost or confused, press the HOME key repeatedly until you get back to the Main Menu and start again.

The following is a detailed example of how to program your controller. Once you have mastered this exercise, you will be ready to set up controller to your specifications.

IMPORTANT! Please note that in all programming instructions, keypad instructions are presented as all capitals – “ENTER”, items as they appear in the display are presented as all capitals and bold-face – “**SYS DATA.**”

For this exercise, you will set the HI/LO AL (high/low alarm) configuration, and SET PT (set point) configuration.

SYS DATA

If not already displayed, press HOME key until display shows **SYS DATA.**

CONFIGUR

Press SCROLL DOWN key until **CONFIGUR** appears in display.

HI/LO AL

Press ENTER. **HI/LO AL** will appear in display. Note: If Option E, Biocide, has been installed, **DATE** will display. If this is the case, Press SCROLL DOWN key until **HI/LO AL** appears in display to complete this exercise. You will program date, time, day, and week in System Configure section of this manual if Option E is present on your controller

HI/LO AL

With **HI/LO AL** showing in display, press ENTER.

TRAK SET

TRAK SET will appear in display, flashing. By pressing either SCROLL UP or SCROLL DOWN, **INDEPEND** will appear flashing. These are the only two choices. In this example, you will select **TRAK SET**.

INDEPEND

You have the choice to select "Track Set Point" or "Independent Set Point." "Track Set Point" triggers Hi or Low alarm based on the same Alarm Offset range over or under the controller set point.

"Independent Set Point" allows you to enter High and Low values of your choice over or under the controller set point. The values for "Track Set Point" or "Independent Set Point" are set in the **SET PTS** selection in the menu.

TRAK SET

Press either SCROLL key to display **TRAK SET**, flashing. Press ENTER. This executes your selection.

The next item in the **CONFIGUR** menu, **SET PT**, appears in the display. Press ENTER.

SET PT

RISING will appear in display, flashing. By pressing either SCROLL UP or SCROLL DOWN, **FALLING** will appear flashing. These are the only two choices. In this example, you will select **RISING**.

RISING

The Rising or Falling Set Point is the setting at which the controller activates an output, such as a solenoid valve when the conductivity (MCT110), pH (MCT120) set point is exceeded. ORP (MCT130) typically uses a falling set point, so that if ORP drops below a certain value the output will activate.

FALLING

Press either SCROLL key to display **RISING**, flashing. Press ENTER. This executes your selection.

RISING

The next item in the **CONFIGUR** menu, **VERSION** (software version), appears in the display. Press HOME repeatedly until **SYS DATA** is displayed.

VERSION

This concludes the sample programming exercise. The instructions for the functions in the this exercise, as well as all **CONFIGUR** menu items are explained in the System Configure section in this manual, page 13.

Repeat this exercise until you feel comfortable with the programming procedure. All functions of the MCT 100 Series controllers will be programmed using this same technique.

4. MCT100 Series Controller Set-up

!!WARNING!!

CONTROLLER COULD BE DAMAGED AND VOID WARRANTY!

Controller must be initialized at start up! Refer to Section 3 General Instructions, Initialization, before proceeding any further.

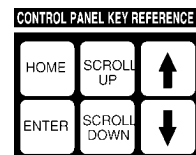

NOTE:

When Initializing or Re-Initializing your controller, all of the system settings will be overwritten by original factory default settings. The controller must be reconfigured to your specifications.

TIP:

After pressing **ENTER** at the end of a setting procedure, if the next item to be set within a submenu does not display, press the **HOME** key to return to the submenu title the press **SCROLL UP** or **SCROLL DOWN** until you see the item to be set next.

a. General Information

Before applying power, insure that devices being controlled are not in a position to cause harm or damage if activated upon initial start-up. With the controller now installed in a convenient location, INITIALIZE Controller (see warning at left!). Supply power to the controller. The power LED indicator light will be illuminated. When controller is powered up, it will show **SYS DATA** in the display.

The PULSAtrol™ is a flexible yet powerful controller. The default values for all Control features have been factory set, but you will want to fine tune the controller to meet your specific application.

SYSTEM CONFIGURE

Configure the controller functions using the key pad and supplied Menu Map. To begin, if **SYS DATA** does not show in the display, press **HOME** repeatedly until **SYS DATA** is displayed. Proceed with the following:

i. System Configure**TIP:**

After pressing **ENTER** at the end of a setting procedure, if the next item to be set within a submenu does not display, press the **HOME** key to return to the submenu title the press **SCROLL UP** or **SCROLL DOWN** until you see the item to be set next.

TIP:

For help with menu locations, please refer to the **Menu Map** supplied with your controller.

ii. Date, Time, Day, Week

Date, Time, Day, Week settings (A through D below) will be available only if Option E, Biocide Programming has been installed in your controller. If this option is not in your controller begin at E, Alarm Configuration.

A) Set DATE:

Press **SCROLL DOWN** until **CONFIGUR** is displayed.

Press **ENTER**, **DATE** will be displayed, press **ENTER**.

Month/ Date/ Year (shown as **01/01/94**) will be displayed with Month flashing. Use **ARROW** keys to enter the current month. Press **ENTER**. Do the same procedure to set Date and Year. Press **ENTER** when finished with Year. **TIME** should display next.

B) Set TIME:

With **TIME** displayed in the window, press ENTER.

Hours:Minutes (24 hour clock shown as **00:00**) will be displayed with Minutes flashing. Use the ARROW keys to enter the current minutes. Press ENTER, Hours will begin to flash. Use ARROW keys to enter current hour. Press ENTER, **DAY** should display next.

C) Set DAY:

With **DAY** displayed in the window, press ENTER.

SUNDAY or another day of the week will be displayed. Use the SCROLL key to show the current day. Press ENTER, **WEEK** should display next.

D) Set WEEK:

With **WEEK** displayed in the window, press ENTER.

1ST WEEK or 2nd through 4th week will be displayed. Use the SCROLL keys to show the current Week. Press ENTER, **HI/LO** should display next.

iii. Hi Lo Alarm

E) Set HI LO ALARM

You have the choice to select “Track Set Point” or “Independent Set Point.” “Track Set Point” triggers Hi or Low alarm based on the same Alarm Offset range over or under the controller set point.

“Independent Set Point” allows you to enter Hi and Low values of your choice over or under the controller set point.

The values for Track Set Point or Independent Set Point are set in the **SET PTS** Menu.

With **HI/LO AL** displayed in the window, press ENTER.

INDEPEND will be displayed, flashing. Press SCROLL UP or SCROLL DOWN to display **TRAK SET**, flashing. By pressing either of the SCROLL keys, the display will toggle between the two options. Press ENTER when your choice is displayed. **SET PT** should display next.

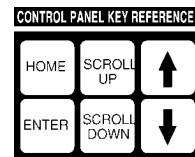

iv. Control Set Point

F) Set CONTROL SET POINT

This setting gives you the option to configure either a rising or falling set point for Conductivity (MCT110), pH (MCT 120) or ORP (MCT130) values. A rising set point means that relays are activated above the set point, falling set point means that relays are activated below the set point. Depending on which model of MCT100 Series controller you have, your choice of control set point will be available for System Conductivity, System pH or System ORP. All configure in the same manner as described below.

With **SET PT** displayed in the window, press ENTER.

RISING will be displayed, flashing. Press SCROLL UP or SCROLL DOWN to display **FALLING**, flashing. By pressing either of the SCROLL keys, the display will toggle between the two options. Press ENTER when your choice is displayed.



VERSION should display next.

v. View Software Version

G) View **VERSION**

This selection lets you view the system software version which is installed on your controller. No settings or adjustments can be made in this menu. This is for information purposes only.

With **VERSION** displayed in the window, press ENTER.

2.00 or whatever version software that is installed in your controller will be displayed. Press ENTER, **SENSITIVITY** should display next.

vi. Set Sensitivity

H) Set **SENSITIVITY**

The setting determines the average number of seconds before a new reading is displayed. This reduces the typical fluctuation of digital displays.

With **SENSITIV** displayed in the window, press ENTER.

1 through **20** seconds will be displayed. Press the ARROW keys to display the number of seconds you want.

Press ENTER, if Option C, "Selectable Timer" is installed in your controller, **FEED SEL** should display next. If Option C is not installed, **ALOGOUT**, Option M, "Analog Output" will display.

If either Option C or Option M is not installed, **HI/LO** will display. Press HOME twice or more to return to **SYS DATA**, and proceed to next section of this manual.

If Option C (Selectable Inhibitor Timer) and/or Option M (Analog Out) are installed, proceed with instructions I) and J).

vii. Selectable Inhibitor Feed Timer (mode selection)

NOTICE:

When configuring Inhibitor Feed Timer In System Configure menu, you may select only one of the modes present.

TIP:

For help with menu locations, please refer to the Menu Map supplied with your controller.

I) Set **SELECTABLE TIMER** (Option C)

This selection lets you choose the method desired to control the operating duration of the inhibitor feed pump when activated by system blowdown.

With **FEED SEL** displayed in the window, press ENTER.

LIMIT will be displayed, flashing. Press SCROLL DOWN to display **PERCENT**, flashing. Press SCROLL DOWN to display **% BLEED**, flashing. Press SCROLL DOWN to display **% BLEED**,

flashing. Press SCROLL DOWN to display **PULSE**, flashing. By pressing either of the SCROLL keys, the display will toggle between the four options. Press ENTER when your choice is displayed. **ALOGOUT** should display next.

If Option M is not installed, **HI/LO** will display. Skip J) Set Analog Output, press HOME twice or more to return to SYS DATA, and proceed to SET POINTS AND ALARMS section of this manual, pg. ??.

viii. Analog Output Settings

J) ANALOG OUTPUT(Option M3)

The M2Options is an output designed for interfacing with recorders, pumps and computers.

Option M3 Maximum and Minimum set points are set at ALOGOUT under the CONFIGUR menu. Refer to Section 5, System Calibration -Analog Output Calibration pg. 24, for instructions on calibrating the “M” options.

Setting “Min” set point and “Max” set point (M-3 Option)



Press HOME key until **SYS DATA** is displayed. Press SCROLL DOWN through the displayed main menus to **CONFIGUR**. Press ENTER, and SCROLL DOWN until **ANLOGOUT** is displayed.

Press ENTER. **MIN** should display. Press ENTER, **0** or the last value entered will appear in the display, flashing. Use the ARROW keys to set the “Min” set point, press ENTER.

MAX will be displayed. Press ENTER **1400** or the last value entered will appear in the display, flashing. Use the ARROW keys to set the “Max” set point, press ENTER.

Press HOME key repeatedly to return to **SYS DATA**.

ix. Scale/Range

NOTE:

After changing scale, you must recalibrate the sensor/probe.

K) CHANGING SCALE/RANGE(MCT110) only

Your PULSAtrol™ comes from the factory pre-configured to monitor conductance 0-5,000 µS/cm. The scale can be changed by setting switch S1 on the mother board, Figure 15, to the desired scale (refer to Diagram 7, page 32) and moving jumper on daughter board, Figure 16, (refer to Diagram 6, page 31)

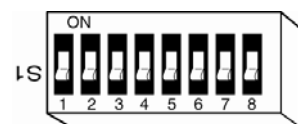

FIGURE 15
Changing Scale on mother board at switch S1, (Settings shown for a range of 0-5,000 uS/cm.

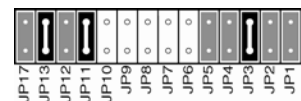

FIGURE 16
Moving jumper on daughter board to change scale.

NOTE:

Electrical wiring is only required for water meter (if used) in the Pulse Timer mode. Refer to Electrical Wiring, pg7 in the instruction manual.

b. Selectable Inhibitor Feed Timer

SELECTABLE INHIBITOR FEED TIMER (Option C)

MCT100 s with Option C, Selectable Timer will have this menu. The inhibitor feed timer is selectable; the user can choose one of four modes on which to base the addition of inhibitor. The selection of timer modes is made in the **CONFIGUR** menu. Only the mode selected in the **CONFIGUR** menu will be displayed in the **INH FEED** menu. Refer to the following timer mode instructions for the mode selected in the **CONFIGUR** menu.

!!WARNING!!

If **PULSE SET** is entered to zero (0), pulse timer will run continuously.

NOTICE:

The Pulse Counter will store one (1) overlapping pulse, if received while pumping.

NOTICE:

TOTALIZER keeps track of water meter pulses. Totalizer will count even if the system is not in pulse timer feed mode and a water meter with a contact head its connected.

Pulse Timer/Accumulator (PULSE T)

Also referred to as a water meter timer or reset timer. The timer accepts pulses from a water meter to actuate a chemical feed pump. The timer has an adjustable feed time **DURATION** in 1 second increments up to 250 minutes and 59 seconds. The timer has a built in accumulator **ACC SET** that can count pulses up to 255 before activating output. Also incorporated into the timer is a pulse totalizer **TOTAL CT** that keeps an ongoing count of the number of pulses received by the timer. This pulse totalizer can be reset to zero by turning power off and back on.

Press HOME key until **SYS DATA** is displayed. Press SCROLL DOWN through the displayed main menus to **INH FEED**. Press ENTER, **PULSE T** will be displayed.

SYS DATA

Press ENTER, **DURATION** will be displayed.

Press ENTER, **00MN00S** (00minutes/00seconds), the factory setting or the last minute setting entered will be displayed with seconds flashing. Use the ARROW keys to display the desired seconds, press ENTER. Minutes will begin flashing. Use the ARROW keys to display the desired minutes. Press ENTER to enter minutes, **ACC SET** will be displayed.

Press ENTER and the factory setting or the last accumulator setting entered will be displayed flashing. Use the ARROW keys to display the desired number of pulses before pump is to activate. Press ENTER to enter accumulator setting. **TOTAL CT** will be displayed.

Press ENTER and the total number of pulses received from the water meter will be displayed. This number multiplied by gallons per contact of the water equal the total gallons used. To reset, remove power and reapply power. Press HOME to return to **TOTAL CT**.

Press HOME repeatedly to return to **SYS DATA**.

Feed Limit Timer (LIMIT).

Also referred to as lock-out timer. The chemical feed pump is actuated based on conductivity, pH or ORP simultaneously with the output. The timer limits the length of time the pump can be activated during any single blowdown cycle preventing over feeding that could occur if the blowdown line were restricted. The timer is adjustable in one minute increments up to 23 hours and 59 minutes.

SYS DATA

Press HOME key until **SYS DATA** is displayed. Press SCROLL DOWN through the displayed main menus to **INH FEED**. Press ENTER, **LIMIT** will be displayed.

Press ENTER, **00HR30MN** (00 hours/30 minutes), the factory setting or the last setting entered will be displayed with minutes flashing. Use ARROW the keys to display the desired minutes. Press ENTER to enter minutes. Hours will begin flashing. Use ARROW the keys to display the desired hours. Press ENTER to enter hours. **LIMIT** will be displayed.

Press HOME repeatedly to return to **SYS DATA**.

TIP:

TO RESET LIMIT TIMER: 1) Interrupt flow through flow assembly, if installed. 2) Satisfy the condition by manually feeding, etc.

10 Minute Percent Timer (PERCENT).

Also referred to as cycle timer. The timer runs continuously on a ten minute cycle with the outputs being activated for a adjustable percentage of the ten minute cycle. The timer is adjustable in one percent increments up to 100 percent of ten minutes on time.

Press HOME key until **SYS DATA** is displayed. Press SCROLLDOWN through the displayed main menus to **INH FEED**. Press ENTER, **PERCENT** will be displayed.

SYS DATA

Press ENTER and the factory setting or the last percent setting entered will be displayed flashing. Use the ARROW keys to display the desired percent of pump on time. Press ENTER to enter percentage. **PERCENT** will be displayed.

Press HOME repeatedly to return to **SYS DATA**.

Post Bleed Percent Timer (% BLEED).

The timer is adjustable in one percent increments up to 100 percent of the blowdown time. The timer keeps track of the total blowdown time and activates the chemical feed when the blowdown deactivates for the percent of total blowdown time set.

Press HOME key until **SYS DATA** is displayed. Press SCROLL DOWN through the displayed main menus to **INH FEED**. Press ENTER, **% BLEED** will be displayed.

SYS DATA

Press ENTER and the factory setting or the last percent setting entered will be displayed flashing. Use the ARROW keys to display the desired percent. Press ENTER to enter percentage of bleed time. **% BLEED** will be displayed.

Press HOME repeatedly to return to **SYS DATA**.

IMPORTANT:

Before the biocide can be programmed, the DATE, TIME, DAY and WEEK must be programmed into the controller. This is accomplished in the CONFIGUR menu, see pg 13.

c. Biocide Programs

PULSAtrol™ biocide programs are on a 28 day cycle. Each biocide had four individual programs with a wide range of day and week setting combinations. The biocide program timers incorporate bleed lock-out with pre-bleed on those controllers incorporating conductivity control. For your convenience, there is a Biocide work sheet in the back of this manual that you may copy to document your Biocide Program records.

Press HOME key until **SYS DATA** is displayed. Press SCROLL DOWN through the displayed main menus to **BIO A**. Press ENTER, **PROGRAM1** will be displayed.

SYS DATA

Press ENTER, **WEEK P1** will be displayed. Press ENTER and **NO WEEK** (the factory setting) or the last week setting entered will be displayed flashing. Use the ARROW keys to set the desired week (see Biocide Week settings below) that biocide A, program 1 is to operate, press ENTER. **DAY P1** will be displayed. If not, press HOME to return to **WEEK P1** and SCROLL DOWN to **DAY P1**.

BIOCIDE "WEEK" SETTINGS		BIOCIDE "DAY" SETTINGS	
NO WEEK	4 th WEEK	SUN	THU
1 st WEEK	EVEN WEEK	MON	FRI
2 nd WEEK	ODD WEEK	TUE	SAT
3 rd WEEK	EVERY WEEK	WED	EVERY

Press ENTER and **FRIDAY** (the factory setting) or the last day setting entered will be displayed flashing. Use the ARROW keys to set the desired day (see Biocide Day settings above) that biocide A, program 1 is to operate, press ENTER. **START P1** will be displayed. If not, press HOME to return to **DAY P1** and SCROLL DOWN to **START P1**.

NOTE:

If programs are not programmed or if set to NO WK after being previously set, they will not activate. Refer to the Biocide programming work sheet, pg 46.

NOTE:

RUN TIME, BLD LKOT, and PREBLEED settings are common to all four biocide programs.

Program Start Time (STARTP1)

The four programs have individual program start times. If system incorporates a conductivity control, pre-bleed would activate at this time.

Press ENTER and **00:00** (the factory setting) or the last start time setting entered will be displayed with minutes flashing. Set minutes with the ARROW keys and press ENTER. Hours will begin to flash. Use ARROW keys to set hours and press ENTER. This sets the desired time that biocide A, program 1 is to start. **WEEK P1** will be displayed. If not, press HOME to return to **START P1**. Press HOME again, to return to **PROGRAM1**.

SCROLLDOWN to **PROGRAM2**, repeat steps 2 through 4 for biocide A program 2.

SCROLLDOWN to **PROGRAM3**, repeat steps 2 through 4 for biocide A program 3.

SCROLLDOWN to **PROGRAM4**, repeat steps 2 through 4 for biocide A program 4.

Length of Feed Time (RUN TIME)

The length of time that biocide A feed pump is to operate.

SCROLL DOWN to **RUN TIME**. Press ENTER.

Press ENTER and **00HR:00MN** (the factory setting) or the last start time setting entered will be displayed with minutes flashing. See minutes with the ARROW keys and press ENTER. Hours will begin to flash. Use ARROW keys to set hours and press ENTER. This sets the desired time that biocide A pump is to feed. **BLD LKOT** will be displayed. If not,press HOME to return to **RUN TIME** and SCROLL DOWN to **BLD LKOT**.

Bleed Lock-Out (BLD LKOT)

This function is only present if conductivity control is also incorporated. The length of time blowdown is to be locked out during and after biocide feed. The lock-out time starts when the feed is activated.

SCROLLDOWN to BLD LKOT. Press ENTER.

00HR00MN (the factory setting) or the last bleed lock-out time setting entered will be displayed flashing. Set minutes with the ARROW keys and press ENTER. Hours will begin to flash. Use ARROW keys to set hours and press ENTER. This sets the desired length of time bleed is to be locked out. **PREBLEED** will be displayed. If not, press HOME to return to **BLD LKOT** and SCROLL DOWN to **PREBLEED**.

Pre-Bleed (PREBLEED)

This function is only present if conductivity control is also incorporated. The pre-bleed function of this controller allows for the user to pre-bleed in advance of the bleed lock-out to reduce the possibility of scaling due to increased TDS levels. Pre-bleed is programmed for a length of time that starts when the biocide program start time, **START** has been programmed and continues for the length of time programmed or until the preset conductivity low limit, **MIN COND** has been reached.

SCROLL DOWN to **PREBLEED**. Press ENTER and **MIN COND** will be displayed, press ENTER. The factory setting, 0, or the last minimum conductivity limit setting entered will be displayed flashing. Use ARROW the keys to set the desired minimum conductivity limit for pre-bleed, press ENTER. **MAX TIME** will be displayed. If not, press HOME to return to **MIN COND** and SCROLL DOWN to **MAX TIME**, Press ENTER.

00HR00MN (the factory setting) or the last pre-bleed time setting entered will be displayed flashing. Set minutes with the ARROW keys and press ENTER. Hours will begin to flash. Use ARROW keys to set hours and press ENTER. This sets the desired length of time the system is to pre-bleed. **MIN COND** will be displayed. If not, press HOME to **MAX TIME**.

TIP:

After pressing ENTER at the end of a setting procedure, if the next item too be set within a submenu does not display, press the HOME key to return to the submenu title then press SCROLL UP or SCROLL DOWN until ou see the item to be set next.

NOTICE:

Set Point can be either R=rising or F= falling depending on setting made at the Set Point selection under the CONFIGUR menu.

NOTE:

Set Track or Independent Set point in the System Configure menu. See Section 4, E, pg

NOTE:

AL OFFSET will be displayed is TRAK SET was selected in the CONFIGUR menu. HI ALARM will be displayed if INDEPEND was selected in the CONFIGUR menu.

d. Set Points and Alarms

i. Rising or Falling Set Point

Rising or Falling Set Points

Every analog input has a Set point (Trip Point), the setting at which the controller activates an output, such as solenoid valve when conductivity set point is exceeded, or an acid pump when pH exceeds the desired limit.

Set point display abbreviations
 Conductivity Rising Set Point -**COND RSP**
 Conductivity Falling Set Point -**COND FSP**
 pH Rising Set Point -**PH RSP**
 pH Falling Set Point -**PH FSP**
 ORP Rising Set Point – **ORP RSP**
 ORP Falling Set Point – **ORP FSP**

Press HOME key until **SYS DATA** is displayed. Press SCROLL DOWN through the displayed main menus to **SET PTS**. Press ENTER, **COND RSP** (Conductivity Rising Set

SYS DATA

Point selected in **CONFIGUR** menu) will be displayed for the MCT110. **PH RSP** (pH Rising Set Point selected in **CONFIGUR** menu) will be displayed for the MCT120. **ORP FSP** (ORP Falling Set Point selected in **CONFIGUR** menu) will be displayed for the MCT130.

Press ENTER. **1500** (the factory setting) or the last set point entered will be displayed flashing. Use the ARROW keys to set the desired set point. Press ENTER to enter the set point value. **ALOFFST** will be displayed.

ii. High or Low Alarm Settings

High or Low Alarm Settings

Every analog input has a high/low alarm, the alarms can be configured one of two ways. The controller is factory configured to track the set point meaning an alarm offset is entered that sets the alarm point above and below the set point of the controller. Example: "**AL OFFST**" 200, if the set point is 1200 the high alarm would be at 1400 and the low alarm at 1000. The high/low alarms can also be configured with independent set points for the "HI ALARM" and the "LO ALARM", this is accomplished through the **CONFIGUR** menu.

Alarm Display abbreviations

Alarm Offset-**AL OFFST**, will be displayed if TRAK SET was selected in the CONFIGUR menu. Continue with steps 3 through 5.

High Alarm - **HI ALARM**, will be displayed if INDEPEND was selected in the CONFIGUR menu. Skip steps 3 through 5, and proceed with steps 6 through 9.

Low Alarm - **LO ALARM**

With **AL OFFST** displayed, press ENTER and **200** (the factory setting) or the last alarm offset entered will be displayed flashing. Press ENTER to enter the Alarm Offset. **SPT DIF** will be displayed.

iii. Set Point Differential

Also referred to as dead band or Hysteresis. The offset applied to a set point to prevent chattering of an output relay around a set point.

Display abbreviation

Set Point Differential – **SPT DIF**

Press ENTER, and **50** (the factory setting) or the last set point differential entered will be displayed flashing. Use the ARROW keys to set the desired set point differential. Press ENTER.

COND RSP should display. Press the HOME key repeatedly to return to **SYS DATA**.



With **HI ALARM** displayed, press ENTER. **1700** (the factory setting) or the last high alarm setting entered will be displayed flashing. Use the ARROW keys to set the desired high alarm. Press ENTER to set the high alarm. **LO ALARM** will be displayed.

With **LO ALARM** displayed, press ENTER. **1300** (the factory setting) or the last low alarm setting entered will be displayed flashing. Use the ARROW keys to set the desired low alarm. Press ENTER to set the low alarm. **SPT DIF** will be displayed.

Press ENTER, and **50** (the factory setting) or the last set point differential entered will be displayed flashing. Use the ARROW keys to set the desired set point differential. Press ENTER.

COND RSP should display again. Press the HOME key repeatedly to return to **SYS DATA**. On the MCT120 controller **LIMIT** will be displayed, proceed with 10 and 11.



iv. Limit Timer

Limit Timer

Also referred to as lockout timer or feed limit timer. Displayed only on MCT120 controller with pH analog input or MCT130 with ORP analog input. This limits the amount of time output is activated. The timer is adjustable in one minute increments up to 24 hours; factory set for 1 hour, 30 minutes.

With **LIMIT** displayed, press ENTER. 01HR:30MN (the factory setting) or the last time entered will be displayed flashing. Use the ARROW keys to set the desired Limit Time. Press ENTER to set the limit time .

PH RSP (MCT120) or **ORP FSP** (MCT130) should display again. Press the HOME key repeatedly to return to **SYS DATA**.



IMPORTANT:

Always put the sensor in calibration solution before, or while the low, middle, or high calibrations steps are being displayed and before pressing ENTER.

5. System Calibration

For a higher degree of accuracy, a PULSAtrol™ Kit (CALKIT), not included, should be used (see Fig. 17). It provides the same physical area for a sample chamber as your on-line sample stream assembly, and three standard calibration solutions. **WARNING:** If not using a calibration chamber, the readings will vary as the sensor is moved from side to side or up and down in the container used as a sample chamber. Also

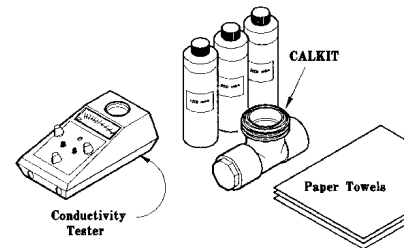

FIGURE 17
CALKIT shown with tester and paper towels.

allow the temperature to stabilize for three minutes after relocating the probe.

Other low cal solution values (other than zero) can be used, but the low cal solution should always be lower than the operating range.

Make sure probe is clean (refer to Section 10, Maintenance, page 40) before proceeding with system calibration.

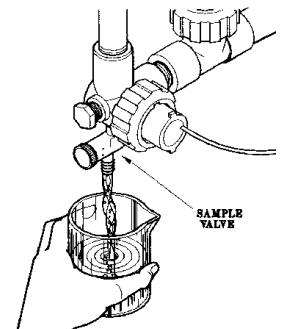

FIGURE 18
Securing a sample of cooling tower water.

Obtain a sample of system water from the sample flow stream (Figure 18), test the sample with a reliable, calibrated tester (Figure 19). If a non-temperature compensated tester is used, manually compensate or bring sample to 25C (77F) and read the conductivity of the sample. If the tester and the present reading under the **SYS DATA** menu on the MCT100 controller agree, proceed with programming parameters. If not, proceed with system calibration.

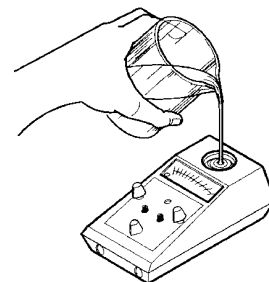

FIGURE 19
Pouring cooling tower sample water into Conductivity tester.

TIP:

When pressing Enter after LO CAL, MID CAL, or HI CAL is displayed, the value shown is what the electrode/sensor is presently reading.

a. Conductivity Calibration (MCT110)

Conductivity - Routine 2 Point System Calibration

Remove sensor for a value of zero (0) to ENTER as “Low Cal”, in Calibration Procedure below (Figure 20).

Replace sensor and use the value obtained with the tester above for Calibration Procedure to ENTER as “Hi Cal.”
Conductivity 2 and 3 Point Calibration Instructions



FIGURE 20
Remove and hold probe in the air to enter “0” for LOW setting.

Press HOME key until **SYS DATA** is displayed. Press SCROLL DOWN through the displayed main menus to **SYS CAL**. Press ENTER, **2/3 PT** will be displayed.



SCROLL DOWN to **2 POINT** or **3 POINT** calibration. Press ENTER and **LO CAL** will be displayed. Remove sensor as shown in Figure 20, then wait 2 minutes. Press ENTER and use the ARROW keys to set the value of calibration solution. Press ENTER to enter the Lo Cal point. **MID CAL** will be displayed if 3 point calibration was chosen. If 2 point calibration was chosen, **HI CAL** will be displayed. Put the sensor back into the line restore flow, wait 2 minutes. Press ENTER and use the ARROW keys to set the value of the tower sample from a hand held tester. Press ENTER to enter the “Mid Cal” point. **HI CAL** will be displayed.

Press ENTER and use the ARROW keys to set the value of calibration solution. Press ENTER to enter the “HI CAL” point. **LO CAL** will be displayed again.



Press the HOME key repeatedly to return to **SYS DATA** to verify acceptance of calibration.

b. pH Calibration (MCT120)

pH Function Calibration Notes

The most common buffers are 4, 7 and 10, but any pH buffers will work if there is at least 3 pH units difference between solutions.

If 2 point calibration is used, always use two buffers that are most representative of the operating conditions. Example: if monitoring around 8 pH use a 4 buffer for the low point and 10 for the high point; if monitoring around 6 pH, use a 4 buffer for the low and 7 for the high.

Between each sample, rinse sensor with next buffer to be sampled.

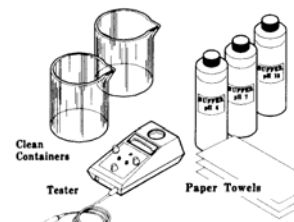
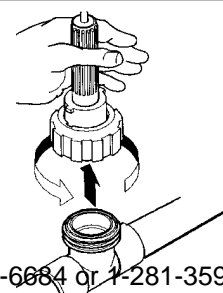

FIGURE 21
Equipment needed for pH probe calibration.



pH Calibration, Method A
(Routine 2 point calibration, preferred)

Obtain a sample of system water and test the sample with a reliable, calibrated pH tester (see Figs. 18 and 19). Make note of reading.

Close isolation valves and relieve pressure on the system by opening the sample valve. Remove probe from flow assembly by unscrewing coupling ring. Pull probe straight up with no side motion to prevent breakage (see Figure 22). Inspect probe, if deposits or fouling is present, clean probe per instructions in Section 9, Maintenance.

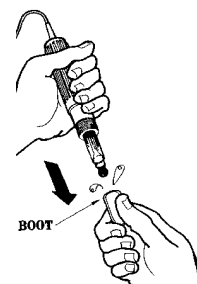

FIGURE 23
Removing protective, liquid filled, rubber boot from probe tip.

!!WARNING!!

Care should be exercised when removing the protective rubber boot from the electrode. Submerge the tip of the electrode in water to loosen the protective boot and remove. Save for future storage. Care should also be taken to prevent the glass bulb from hitting the tee or other piping. Never expose the electrode to air with power on for more than 45 seconds. Never allow electrode to dry out.

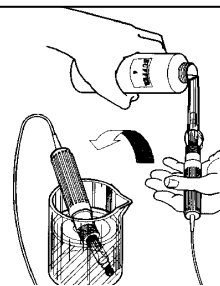

FIGURE 24
Adding pH buffer solution to probe in a clean container for calibration.

NOTE:

Be sure to allow probe/sensor to stabilize for at least 2 minutes each time its environment is changed before evaluating readings.

!!WARNING!!

Probe must be installed in flow assembly before calibrating High setting.

(New probes only) Wet tip of probe and carefully remove the liquid filled, protective rubber boot from the probe's tip (see Figure 23). Do not allow probe's tip to dry out! Save boot for future use.

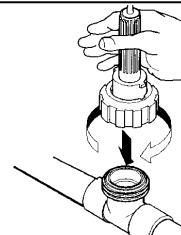

FIGURE 25
Reinstall probe into flow assembly prior to calibration.

Rinse probe in pH4 solution (low cal), then place probe into a clean container and pour enough pH4 buffer solution to cover tip (see Figure 24).

Press HOME key until **SYS DATA** is displayed. Press SCROLL DOWN through the displayed main menus to **SYS CAL**. Press ENTER, **2/3 PT** will be displayed.



SCROLL DOWN to **2 POINT** calibration. Press ENTER and **LO CAL** will be displayed. Press ENTER and use the ARROW keys to enter the value of the low calibration solution. Press ENTER to enter the "Lo Cal" point. **HI CAL** will be displayed.

Reinstall pH probe into flow assembly, close sample valve and open isolation valves (see Figure 25). Important, wait 2 minutes for probe to stabilize before continuing!

Press ENTER and use the ARROW keys to enter the value of the reading obtained in step 1. Press ENTER to enter the Hi Cal point. **HI CAL** will be displayed.

Press the HOME key repeatedly to return to **SYS DATA** to verify acceptance of calibration.

NOTE:

Method A will give better results as you are calibrating the sensor in its operating environment.

NOTE:

Be sure to allow probe/sensor to stabilize for at least 2 minutes each time its environment is changed before evaluating readings.

pH Calibration, Method B
(Alternate 3 point calibration)

Close isolation valves and relieve pressure on the system by opening the sample valve. Remove probe from flow assembly by unscrewing coupling ring. Pull probe straight up with no side motion to prevent breakage (see Figure 22). Inspect probe, if deposits or fouling is present, clean probe per instructions in Section 10, Maintenance, page 40.

Follow steps 3, 4, and 5 in Method A, except at step 6 select **3 POINT**. Press ENTER and **LO CAL** will be displayed.

Rinse pH probe with low buffer solution then place probe in a clean container. Pour enough low buffer solution into the container to cover the probe's tip (see Figure 24). Wait at least 2 minutes for probe to stabilize!

Press ENTER and use the ARROW keys to enter the value of the low calibration solution. Press ENTER to enter the "Lo Cal" point. **MID CAL** will be displayed.

Discard the low buffer solution. Rinse pH probe with mid buffer solution then place probe in a clean container. Pour enough mid buffer solution into the container to cover the probe's tip (see Figure 24). Wait at least 2 minutes for probe to stabilize!

Press ENTER and use the ARROW keys to enter the value of the mid calibration solution. Press ENTER to enter the "Mid Cal" point. **HI CAL** will be displayed.

Discard the mid buffer solution. Rinse pH probe with high buffer solution then place probe in a clean container. Pour enough high buffer solution into the container to cover the probe's tip (see Fig. 24). Wait at least 2 minutes for probe to stabilize!

Press ENTER and use the ARROW keys to enter the value of the high calibration solution. Press ENTER to enter the "Hi Cal" point. **LO CAL** will be displayed.

Discard high buffer solution. Reinstall pH probe into flow assembly, close sample valve and open isolation valves (see Figure 22). Important, wait 2 minutes for probe to stabilize before continuing! Press HOME repeatedly to return to **SYS DATA**. Press ENTER to display data to verify calibration.

c. ORP Calibration (MCT130)

ORP Function Calibration Notes

If 2 point calibration is used, always use two standards that are most representative of the operating conditions.

Between each sample, rinse sensor with next standard to be sampled.

ORP Calibration, Method A

(Routine 2 point calibration, preferred)

Obtain a sample of system water and test the sample with a reliable, calibrated ORP tester (see Figures 18 and 19). Make note of reading.

Close isolation valves and relieve pressure on the system by opening the sample valve. Remove probe from flow assembly by unscrewing coupling ring. Pull probe straight up with no side motion to prevent breakage (see Figure 22). Inspect probe, if deposits or fouling is present, clean probe per instructions in Section 9, Maintenance.

(New probes only) Wet tip of probe and carefully remove the liquid filled, protective rubber boot from the probe's tip (see Figure 23). Do not allow probe's tip to dry out! Save boot for future use.

Rinse probe (low cal), then place probe into a clean container and pour enough solution to cover tip (see Figure 24).

Press HOME key until **SYS DATA** is displayed. Press SCROLL DOWN through the displayed main menus to **SYS CAL**. Press ENTER, **2/3 PT** will be displayed.

SYS DATA

SCROLL DOWN to **2 POINT** calibration. Press ENTER and **LO CAL** will be displayed. Press ENTER and use the ARROW keys to enter the value of the low calibration solution. Press ENTER to enter the "Lo Cal" point. **HI CAL** will be displayed.

Reinstall ORP probe into flow assembly, close sample valve and open isolation valves (see Figure 25). Important, wait 2 minutes for probe to stabilize before continuing!

Press ENTER and use the ARROW keys to enter the value of the reading obtained in step 1. Press ENTER to enter the Hi Cal point. **HI CAL** will be displayed.

Press the HOME key repeatedly to return to **SYS DATA** to verify acceptance of calibration.

ORP Calibration, Method B
(Alternate 3 point calibration)

Close isolation valves and relieve pressure on the system by opening the sample valve. Remove probe from flow assembly by unscrewing coupling ring. Pull probe straight up with no side motion to prevent breakage (see Figure 22). Inspect probe, if deposits or fouling is present, clean probe per instructions in Section 10, Maintenance, page 40.

Follow steps 3, 4, and 5 in Method A, except at step 6 select **3 POINT**. Press ENTER and **LO CAL** will be displayed.

Rinse ORP probe with low buffer solution then place probe in a clean container. Pour enough low buffer solution into the container to cover the probe's tip (see Figure 24). Wait at least 2 minutes for probe to stabilize!

Press ENTER and use the ARROW keys to enter the value of the low calibration solution. Press ENTER to enter the "Lo Cal" point. **MID CAL** will be displayed.

Discard the low buffer solution. Rinse ORP probe with mid buffer solution then place probe in a clean container. Pour enough mid buffer solution into the container to cover the probe's tip (see Figure 24). Wait at least 2 minutes for probe to stabilize!

Press ENTER and use the ARROW keys to enter the value of the mid calibration solution. Press ENTER to enter the "Mid Cal" point. **HI CAL** will be displayed.

Discard the mid buffer solution. Rinse ORP probe with high buffer solution then place probe in a clean container. Pour enough high buffer solution into the container to cover the probe's tip (see Fig. 24). Wait at least 2 minutes for probe to stabilize!

Press ENTER and use the ARROW keys to enter the value of the high calibration solution. Press ENTER to enter the "Hi Cal" point. **LO CAL** will be displayed.

Discard high buffer solution. Reinstall ORP probe into flow assembly, close sample valve and open isolation valves (see Figure 22). Important, wait 2 minutes for probe to stabilize before continuing! Press HOME repeatedly to return to **SYS DATA**. Press ENTER to display data to verify calibration.

6. Analog Output Calibration

C. ANALOG OUTPUT CALIBRATION (Option M-3)

M-3 Option is an Isolated Proportional 4 to 20 mA output, designed to interface with an analog recorder, metering pump or computer. The output is 4 to 20 mA over a programmable range. For example, if the analog input was conductivity, the output could be programmed to be 4 mA at 1200 $\mu\text{S}/\text{cm}$, the "Min" set point and 20 mA at 1500 $\mu\text{S}/\text{cm}$, the "Max" set point.

The M-3 Option, analog outputs require calibration upon initial start up. Calibration is also recommended after changing scales and after factory re-initialization. For accurate calibration of the analog output, a milliamp meter is required. Refer to Diagram 6, Daughter Board, page 31, in the instruction manual for output connections.

Calibration Note: MIN = 4 mA, MAX = 20 mA

Connect milliamp meter to output connections on daughter board connections (Diagrams 6, page 31). Be sure to observe proper polarity (+/-).

Press HOME key until **SYS DATA** is displayed. Press SCROLL DOWN through the displayed main menus to **SYS CAL**. Press ENTER, and SCROLL DOWN until **OUTPUT** is displayed.

SYS DATA

Press ENTER and **MIN** will be displayed.

Press ENTER and **READ VAL** will be displayed flashing. Use the ARROW keys to adjust the "Min" mA reading on the external milliamp meter and press ENTER to enter adjustment. **MAX** will be displayed. If not, press HOME to return to **MIN** and SCROLL DOWN to **MAX**.

Press ENTER and **READ VAL** will be displayed flashing. Use the keys to adjust the "Max" mA reading on the external milliamp meter. Press ENTER to enter adjustment. **MIN** will be displayed. If not, press HOME to return to **MAX**.

Press HOME key repeatedly to return to **SYS DATA**.

NOTE:

When operating scale of the controller is changed, you must recalibrate the Analog Output.

7. Diagrams: Installation, Component, and Electrical

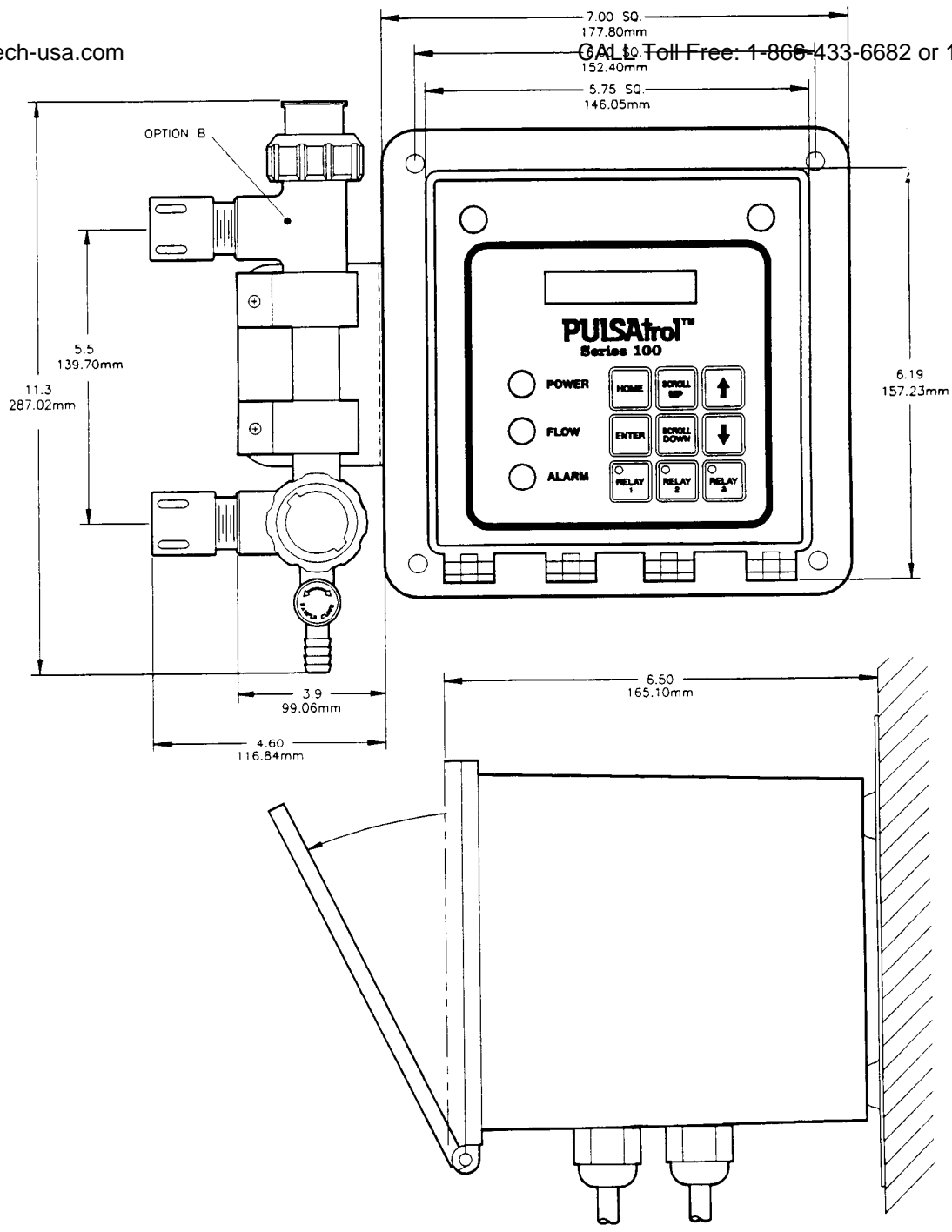

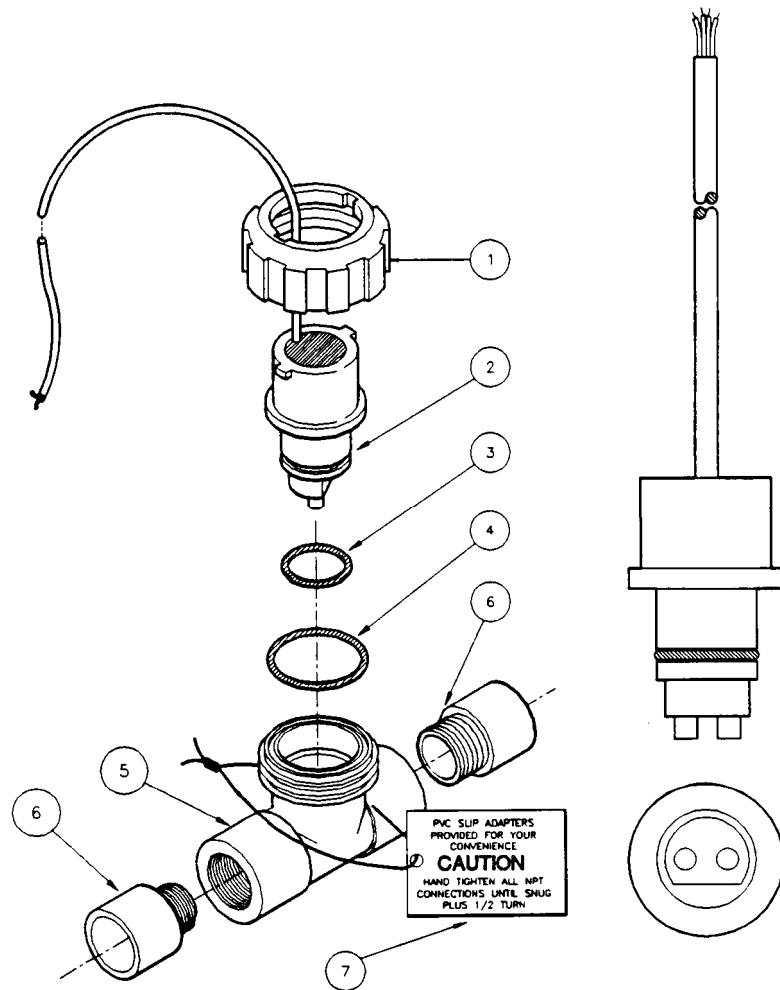

Specifications			
Pressure Rating	125PSI (8.6 BAR)		
Temperature Rating	125F (51.7C)		
Temperature Compensation	45F – 105F (7.2C – 40.6C)		
Construction	Glass Filled Polypropylene Stainless Steel		
Thread Size	3/4" (19.05 mm) NPT		
Wire Color Code			
Red	Electrodes		
Black	Common of Electrodes and Temperature Compensation		
Clear (may be Green or white)	Temperature Compensation		
Bare	Shield		
Materials			
Item	Quantity	Part Number	Description
1	1	06-008-00	Coupling Nut
2	1	04-600-01	Conductivity Electrode Assembly, 10"
3	1	03-005-02	Gasket, O-Ring #2-119
4	1	03-005-04	Gasket, O-Ring #2-029
5	1	03-096-56	Tee, Flow
6	2	03-093-00	3/4" Male Adapter, PVC
7	1	20-110-02	Caution Tag, PVC Adapters

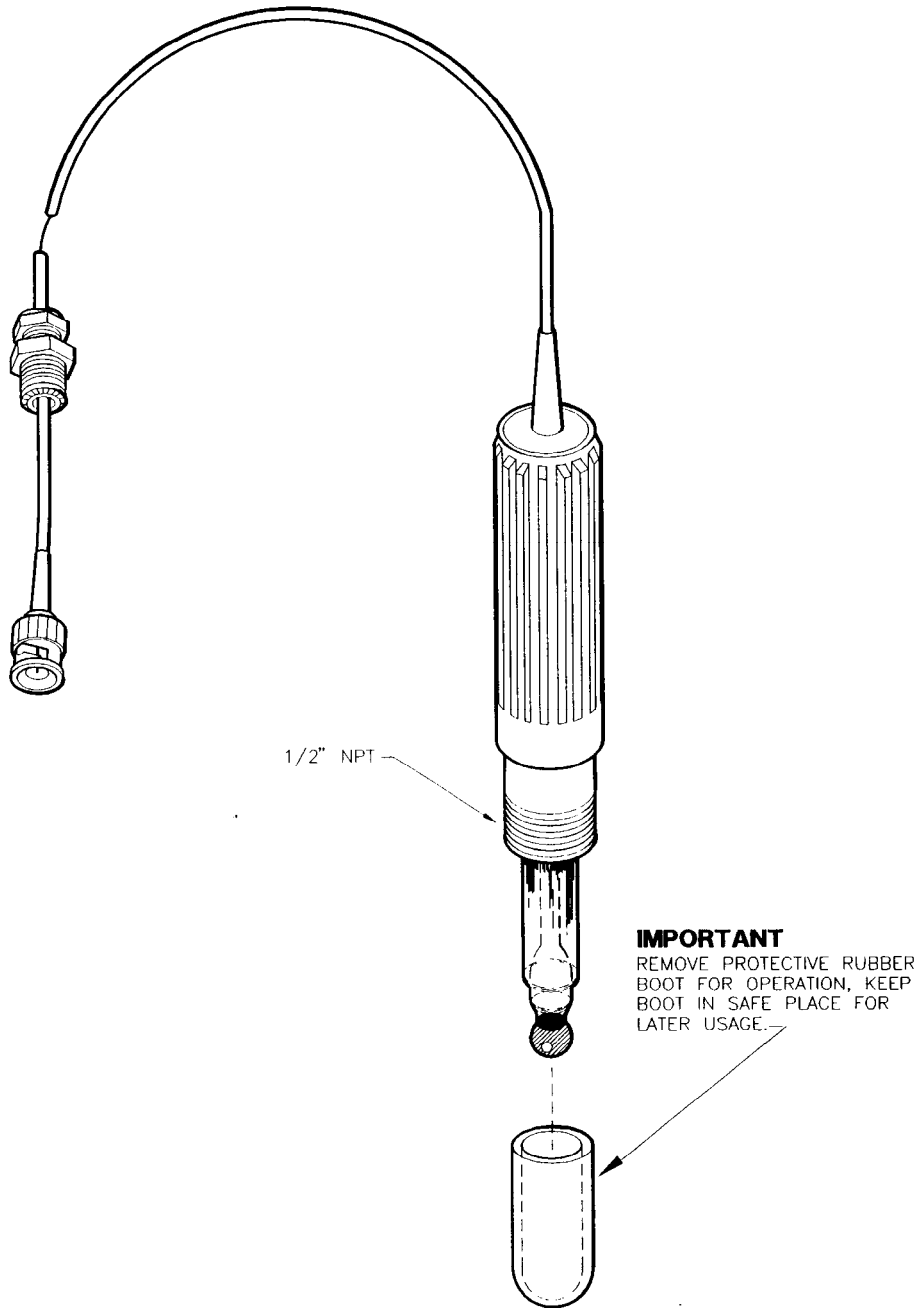

Specifications			
Double Junction			
pH Range			0 – 14 (Na+ <0.1 N)
Accuracy			+/- 0.1 pH Unit
Response Time			< 10 Sec. (95% Response)
Operating Temperature Range			-5 to + 100C
Operating Pressure Range			100 psi
Materials			
Item	Quantity	Part Number	Description
1	1	04-000-00	Electrode, pH,

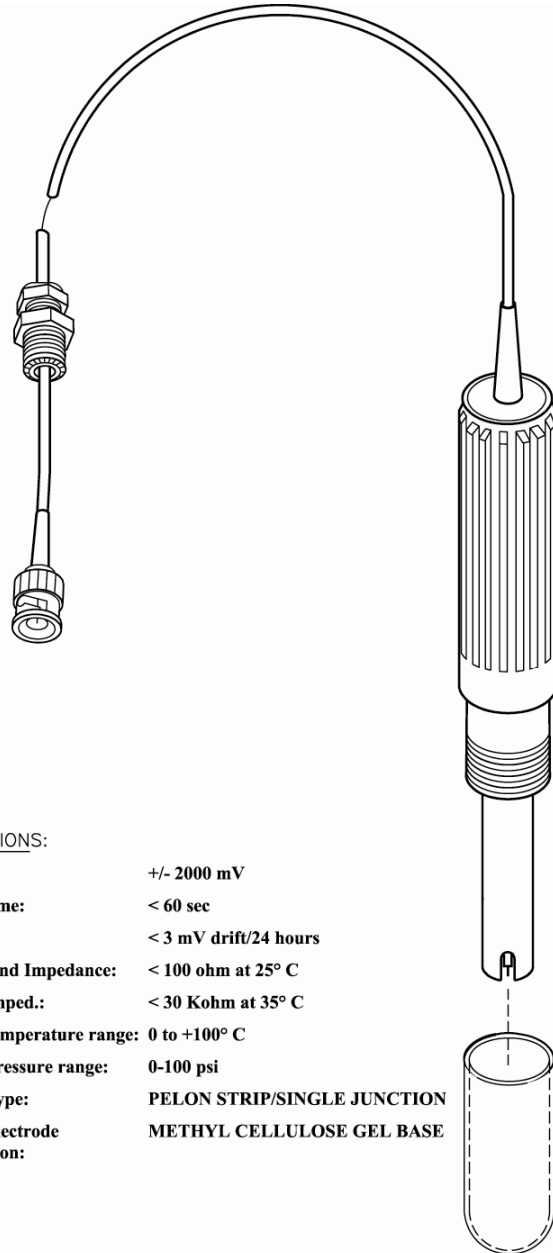

SPECIFICATIONS:

- ORP Range: +/- 2000 mV
- Response Time: < 60 sec
- Stability: < 3 mV drift/24 hours
- Platinum Band Impedance: < 100 ohm at 25° C
- Reference Imped.: < 30 Kohm at 35° C
- Operating temperature range: 0 to +100° C
- Operating pressure range: 0-100 psi
- Reference Type: PELON STRIP/SINGLE JUNCTION
- Reference Electrode Outer Solution: METHYL CELLULOSE GEL BASE

IMPORTANT

REMOVE PROTECTIVE RUBBER BOOT FOR OPERATION. KEEP BOOT IN SAFE PLACE FOR LATER USAGE

MATERIALS

Item 1	Quantity 1	Part No. 04-000-10	Electrode, ORP, OE/ON-1
Specifications			
??			
ORP Range			1,000 MV
Accuracy			+/- 0.1 pH Unit
Response Time			< 10 Sec. (95% Response)
Operating Temperature Range			-5 to + 100C
Operating Pressure Range			100 psi
Materials			
<i>Item</i>	<i>Quantity</i>	<i>Part Number</i>	<i>Description</i>
1	1	04-000-10	Electrode, ORP,

POWER SUPPLY/RELAY BOARD CONNECTIONS

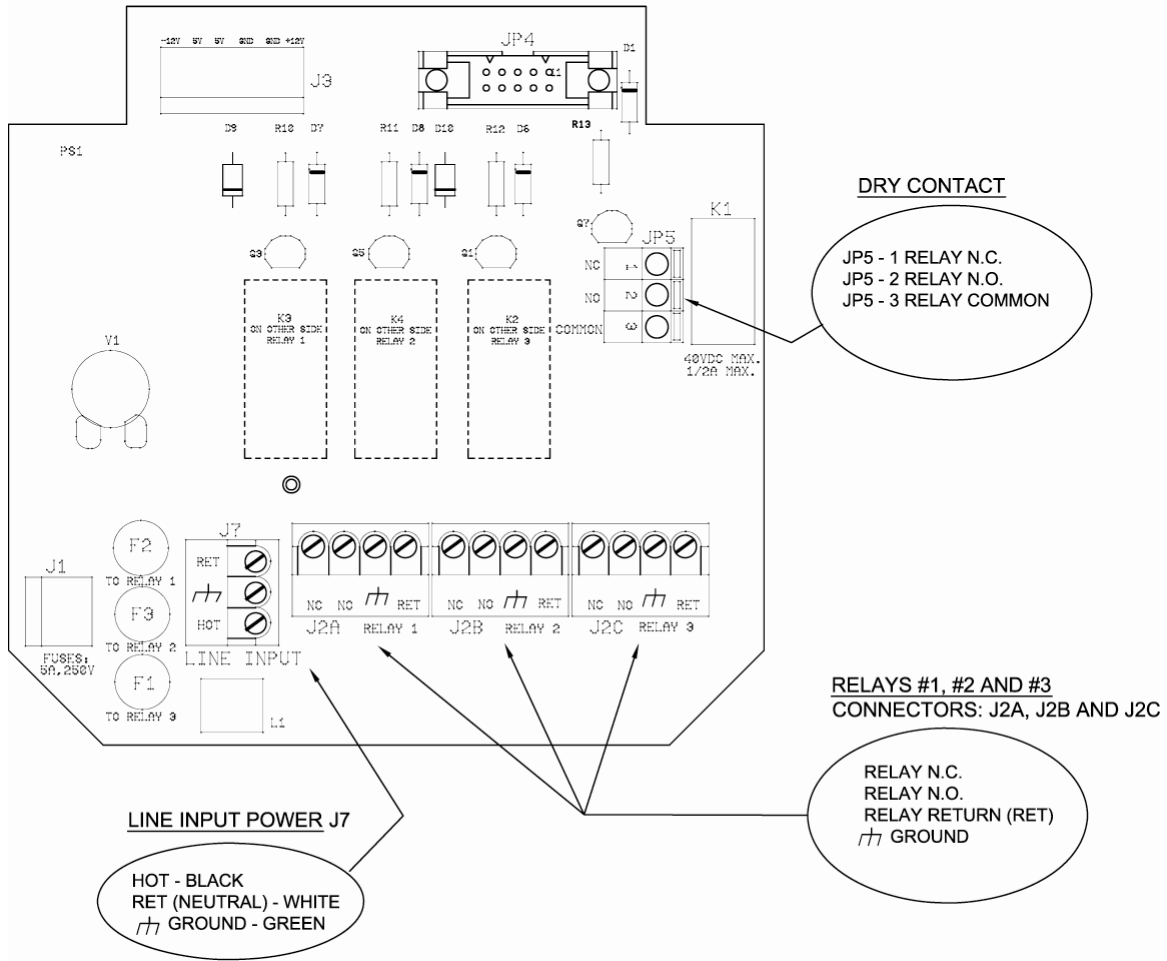

Conduit units are factory predrilled with easily accessible terminals for hard wiring. See Relay Board, Diagram 4, page 29, and Electrical Wiring section in this manual, page 7.

NOTE: Use only 16 or 18 AWG wire for conduit power and load connections. Never run power and signal wiring together in same conduits. (Example: Sensor Outputs with Power wiring)

HOA Key	Relay 1	Relay 2	Relay 3	
Relay/Fuse Connection	A	B	C	D
MCT110	Blowdown	Inhibitor		
MCT110C	Blowdown	Timer Out 1		
MCT110CD	Blowdown	Timer Out 1	Alarm Relay	
MCT110CE	Blowdown	Timer Out 1	Biocide A	
MCT110D	Blowdown	Inhibitor	Alarm relay	
MCT110E	Blowdown	Inhibitor	Biocide A	
MCT120	pH Control			

MCT120C	pH Control	Timer Out 1		
MCT120CD	pH Control	Timer Out 1	Alarm Relay	
MCT120D	pH Control		Alarm Relay	
MCT120E	pH Control		Biocide A	
MCT130	ORP Control			
MCT130C	ORP Control	Timer Out 1		
MCT130CD	ORP Control	Timer Out 1	Alarm Relay	
MCT130D	ORP Control		Alarm Relay	
MCT130E	ORP Control		Biocide A	
Option K				Alarm Dry Contact

INSTRUCTIONS: Find the model number of your controller in the far left column. Options that do not require wiring will not appear in the model number. Find the output in the columns to the right. The connection for that output will be the letter in the row labeled Relay/Fuse Connection.

Use a small screwdriver to depress orange tab and push wire in corresponding hole. Remove pressure from tab and pull on wire to insure a good connection.

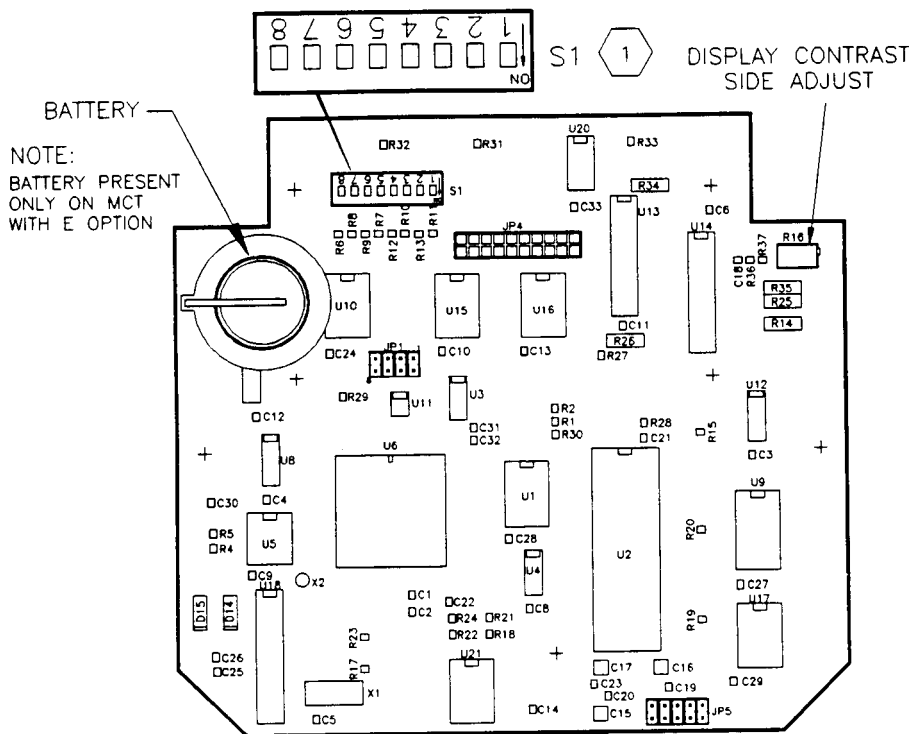
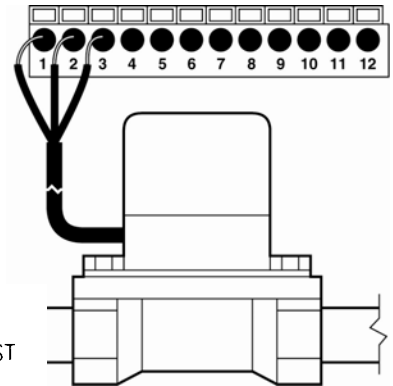

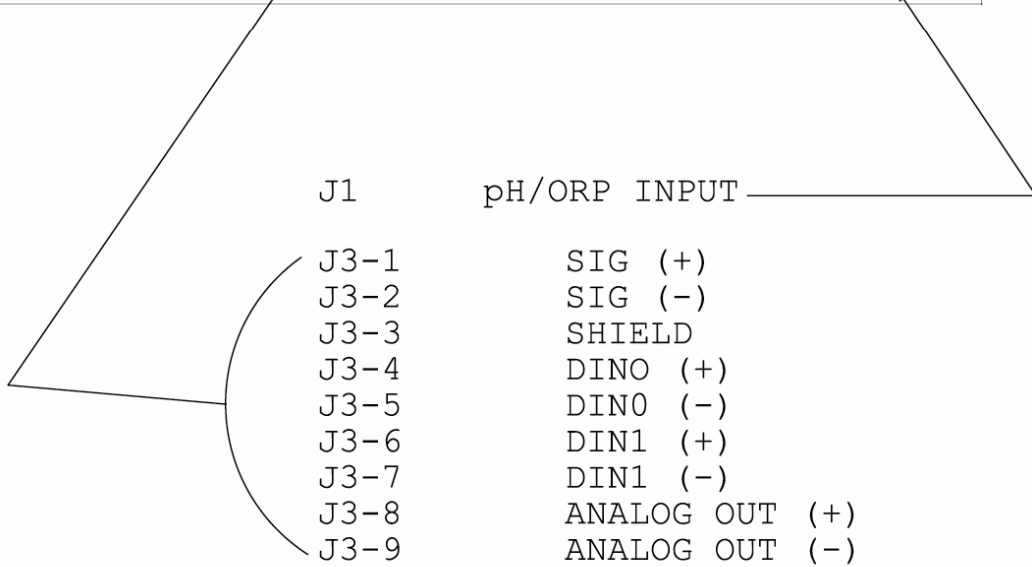
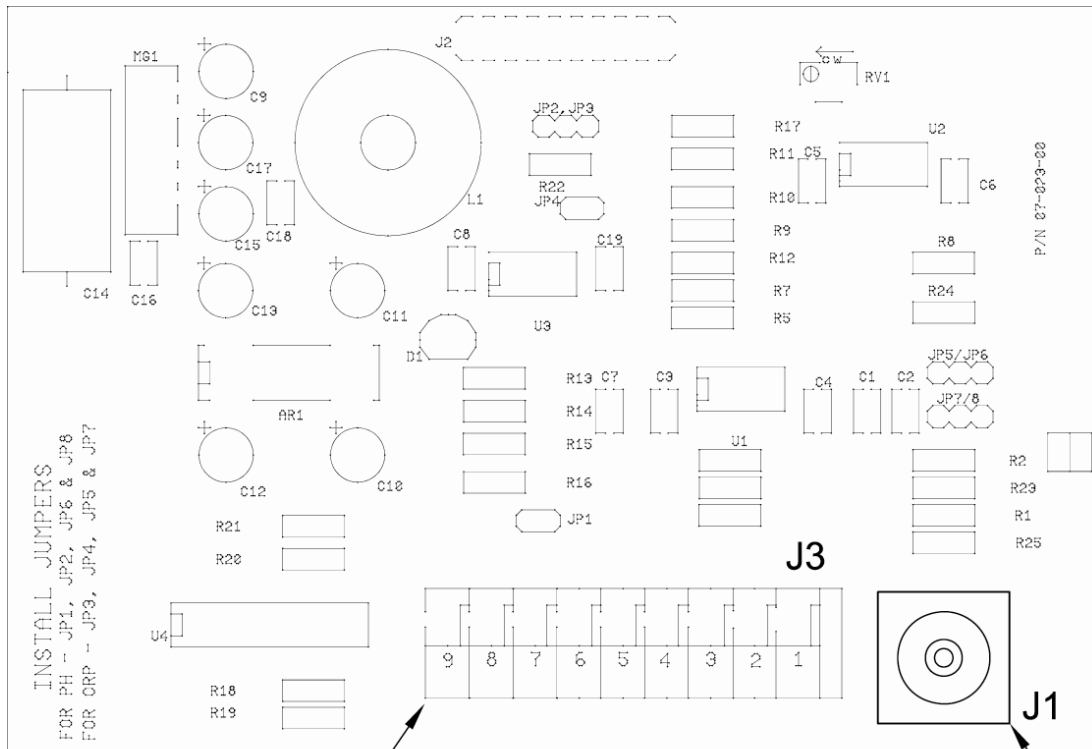

pH/ORP DAUGHTER BOARD

READ THE FOLLOWING BEFORE PROCEEDING ANY FURTHER!!

INITIALIZATION

This unit requires initialization upon start-up (see Figures 11-14 on page 9). There is a lithium battery backup that protects the time and history files during power outages that must be enabled as follows:

Before power is supplied, open front panel by loosening the two screws holding the front cover closed with a phillips screwdriver.

Locate switch S1 on the mother board, refer to Diagram 7, above). Assure switch S1-“8” is in the “ON” position.

With the unit open, locate the battery in the corner of the mother board, behind the front panel. Remove the paper from under the battery clip.

With the front panel closed, turn unit on for 15 seconds. After 15 seconds turn unit off, disconnect power, open front panel. Change switch S1-“8” to the “OFF” position.

Close front panel. Connect power, turn unit on. The unit is now ready to be configured and programmed.

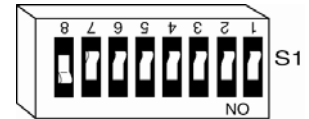

Switch S1-“8” shown in the on position.

NOTE:
THE FLOW ASSEMBLY'S APPEARANCE MAY DIFFER, DEPENDING ON THE CONTROLLER MODEL

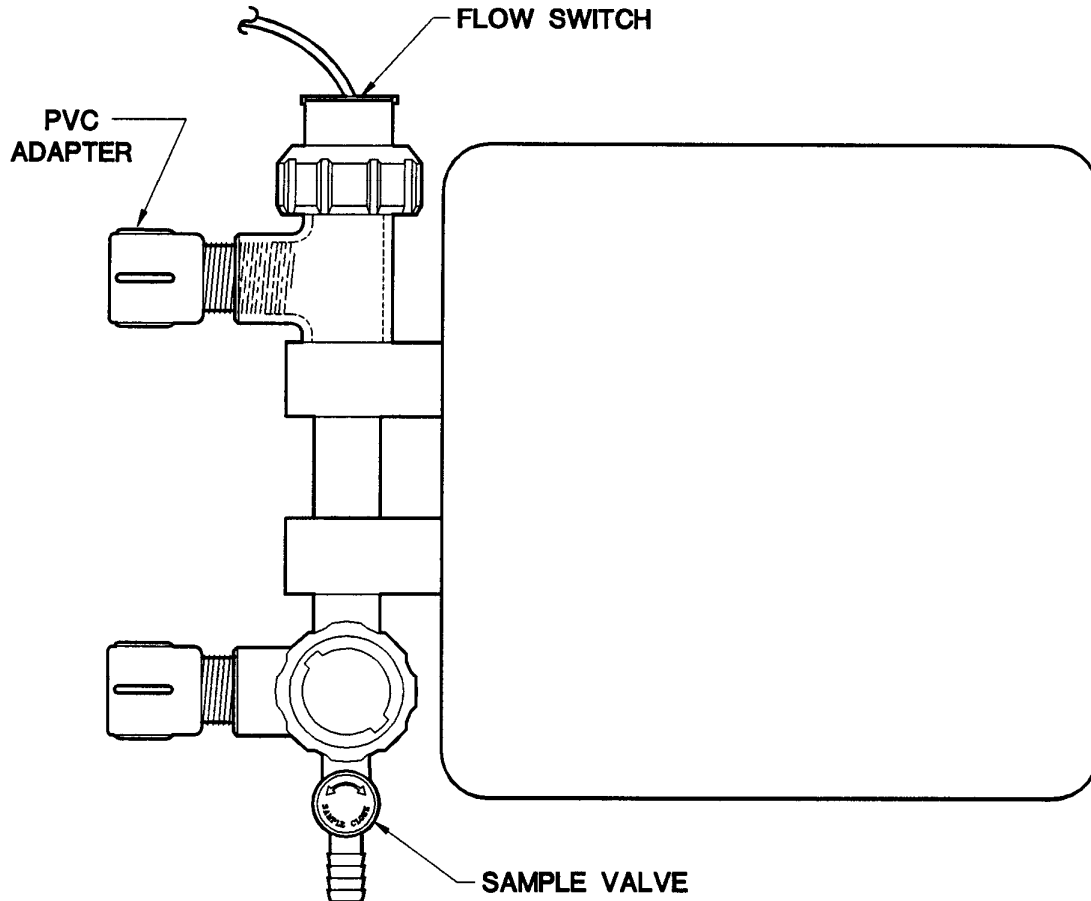

NOTE:

The standard flow assembly provided with this controller is constructed of durable glass-filled polypropylene. Standard connection to the flow line is 3/4" NPT, but we have provided a PVC thread to slip adaptor so that a PVC weld joint, if preferred, can be made. If NPT connections are used, hand-tighten until snug, then tighten an additional half turn.

Material of Construction	Black glass filled polypropylene, PVC and transparent PVC
Plumbing	3/4" slip and threaded, rated for 125 psi (8.62 Bar) at 125F (52C)
Flow Switch	1 USGPM activation, transparent PVC
Sample Valve	Black glass filled polypropylene

8. Specifications

General	
Power Input	110/220 VAC @ 50/60 Hz 100 VA.
Control Output	Line voltage @ 600 VA (5 amps @ 115 VAC) per relay.
Enclosure Prewired	High impact resistant polystyrene designed to NEMA 4X, with convenient molded receptacle cords and power cord with molded plug for electrical connections.
Enclosure Conduit	High impact resistant polystyrene designed to NEMA 4X, factory predrilled with easily accessible terminals for hard wiring.
Display	Alphanumeric 1 line by 8 character lighted LCD display.
H/O/A Switches	Front panel keypad.
Environment	Ambient temp. 0°F (-17.8°C) to 122°F (50°C); relative humidity 0 to 100%.
Dimensions	Width 7" (17.78cm) X depth 6.5" (16.51cm)
Controller Weight	6 lbs (2.5 kgs)
Shipping Weight	8 lbs (3.7 kgs)
Flow Switch or Interlock	Connection provided. Function activated by dip switch if mounted flow switch or remote flow switch not ordered with controller.
Inputs	1 analog and 2 digital
Outputs	1 analog and 2 relays
CONDUCTIVITY FUNCTION	
Electrode	Temperature compensated from 45°F (7.2°C) to 105°F (40.6°C), quick-release 3/4" glass filled polypropylene flow tee. Pressure 125 psi @ 125°F (51.7°).
Set Point	Select rising or falling. Factory set rising @ 1500 µS/cm, rising.
Conductivity Range	Selectable 0 to 500, 2000, 5000, 10,000 & 20,000. Factory set @ 5000 mS/cm.
Accuracy	+/- 1% of full scale, at point of measurement, excluding electrode.
Differential	Adjustable. Factory setting @ 50 µS/cm.
High/Low Alarm	Adjustable. Select track set point or independent set of HIGH and LOW, factory set track set point @ +/-200 µS/cm.
PH FUNCTION	
Electrode	Sealed combination type; KCl-AgCl reference with 3/4" Glass Filled Polypropylene flow tee, 125 psi @ 125°F.
Set Point	Select rising or falling, factory set rising 7.4 pH.
Accuracy	+/- 1% of full scale at point of measure, excluding electrode.
Differential	Adjustable; factory setting 0.2 pH.
High/Low Alarm	Adjustable. Select follow set point or independent set of HIGH and LOW; factory set follow set point +/- 2 pH.
Limit Timer	Adjustable in 1 minute increments up to 24 hours; factory set at 1:30 hr/min.
SUMMARY OF KEYPAD	

Home	When pushed, returns displayed menu back one level in menu structure.
Enter	When pushed, enters displayed variable or value.
Scroll Up	Used to scroll-up through (view) menu structure and to display variables.
Scroll Down	Used to scroll-down through (view) menu structure and to display variables.
Arrow Keys	Used to increase/decrease numerical settings.
Relay Keys	Hand/Off/Auto (HOA) switches, depressing key:
	ONCE – Forces corresponding output relay on for five minutes; LED color amber.
	TWICE – Forces corresponding output relay off indefinitely; LED color red.
	THREE times – Returns control to automatic; LED off if within set point, green if out of set point.
SUMMARY OF LED INDICATOR LIGHTS	
Power Indicator	Illuminates when power is supplied to unit.
Flow Indicator	Illuminates when flow is present through flow switch. This indicator will not be functional or labeled if mounted flow assembly was not ordered. User can activate function site. GREEN – Indicates flow RED – Indicates no flow OFF – Indicates disabled
Alarm Indicator	Flashes red when an alarm condition is present.
Relay Indicators	AMBER if forced on. RED if forced off. OFF if in auto mode and control function is not automatically activated. GREEN if activated automatically.

9. Factory Default Values

	SERIES 100
SYSTEM CONDUCTIVITY SCALE	5000 μ S/cm
High Alarm	1700 μ S/cm
Low Alarm	1300 μ S/cm
Set Point	1500 μ S/cm rising
Set Point Differential	50 μ S/cm
Alarm Offset	200 μ S/cm
SYSTEM Ph SCALE	0-14 pH
High Alarm	9.40 pH
Low Alarm	5.40 pH
Set Point	7.40 pH rising
Set Point Differential	0.20 pH
Alarm Offset	2.00 pH
Limit Timer	01:30 HH:MM
SYSTEM ORP SCALE	0-1000 mV
High Alarm	845 mV
Low Alarm	795 mV
Set Point	820 mV falling
Set Point Differential	20 mV

Alarm Offset	25 mV
MAKE-UP CONDUCTIVITY SCALE	N/A
High Alarm	N/A
Low Alarm	N/A
Set Point Differential	N/A
INHIBITOR TIMER	Limit
Feed Timer	1:00 HH:MM
BIOCIDE TIMERS	
Week	No Week
Day	Friday
Start Time	00:00 HH:MM
Run Time	01:30 HH:MM
Bleed Lock Out Time	00:00 HH:MM
Pre-Blowdown Time	
Conductivity Min	
MISCELLANEOUS	
Hi/Low Alarms	Tracking Set Point
Display Dampener	1 Second
POSSIBLE ALARMS	
All High Alarms	X
All Low Alarms	X
Limit Time pH	X
Limit Time ORP	X
No Flow	N/A
Inhibitor Limit Timers	X
OTHER INHIBITOR FEED MODES	
PULSE TIMER	
Run Time	00:30 MM:SS
Accumulator Set	10
Count Totalizer	1
PERCENT TIMER	
Percent On	5%
% of Minutes	10
% OF POST BLOWDOWN	
% of Blowdown Feed	5%

OTHER SCALES	Max Range	High Alarm	Low Alarm	Set Point	Set Pt. Diff.	Alarm Offset
0-500	500	200	100	150	20	50
0-2000	2000	700	500	600	40	100
0-10000	10000	3300	2700	3000	150	300
0-20000	20000	6600	5400	6000	200	600

10. Troubleshooting Guide

If your controller is not operating properly, proceed through the troubleshooting instructions below.

MOTHER BOARD

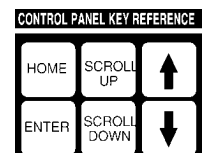

Symptom	Probable Cause	Possible Solution
Inability to keep Time/Date	Battery shipping paper not removed	Remove fish paper from behind battery.

	Battery bad	Replace battery. Use Eveready 3V E-CR2032.
No Display (See Power Supply first)	Improper contrast	Adjust contrast on Mother Board. See Diagram 7, pg. 32
	Environment exceeds 122°F (50°C)	Relocate controller.
	Battery loose	Check fit of battery.
	Battery missing or bad	Replace battery with Eveready 3V E-CR2032.
Erratic Readings	Improperly grounded power	Assure power and ground integrity. Shields of all sensors should be connected at controller end only.
Flow Light Never Activates	Function not activated	Turn switch S1-"2" on mother board ON. See Diagram7, pg. 32.
Flow Light Stays On	Flow switch stuck	Clean flow switch.

POWER SUPPLY/RELAY BOARD
(Series 100 Power Supply located on Relay Board)

Symptom	Probable Cause	Possible Solution	
No Power Light	Blown fuse	Replace fuse on Power Supply/Relay board.	
	Interconnecting cables loose	Check connections.	
	No power supplied	Check power source.	
No Outputs Each relay, on the Relay Board	If the Output front panel LED is lit		
		• Ribbon cable.	Check ribbon cable connection or replace.
		• blown fuse	Replace fuse
	• bad relay	Replace Power Supply/Relay Board	
Front Panel Blowdown LED Stays On	Conductivity of water is above set point, blowdown restricted	Check blowdown line and do one of the following:	
		• Clean strainer.	
		• Clean solenoid. • Replace solenoid.	
	Treatment chemicals or process liquid at sensor	Check sample stream injection of treatment chemicals/process liquid at sensor.	
		Conductivity of sample stream higher than system conductivity, sample stream restricted	Check for flow in sample stream and do one of the following:
			• Clean strainer. • Clean sample line.
Conductivity of Controller Decreases While System Conductivity Increases	Fouled sensor	Clean sensor.	
Conductivity of System Stays Lower Than Set Point, Never Or Rarely Blows Down	Uncontrolled blowdown	Blowdown valve leaking. Do one of the following:	

		<ul style="list-style-type: none"> • Realign ball valve; if leaking by the ball valve.
		<ul style="list-style-type: none"> • Clean solenoid valve; if leaking by the solenoid valve
		Close manual blowdown valve.
		Fix leaks in cooling system.
Front Panel Blowdown LED Cycles On and Off	Air in sample line	Bleed air off.
	Differential (dead band) too tight	Widen differential.
Controller Not Blowing Down With High Solids	Biocide locking out bleed	Wait for programmed biocide activation to end.
Chemical Plump Not Activating	Pulse Timer:	
	<ul style="list-style-type: none"> • Check for flow through water meter 	Renew flow.
	<ul style="list-style-type: none"> • Check water meter contacts 	Replace water meter register.
	<ul style="list-style-type: none"> • Check wiring from controller 	Replace wiring.
Inability To Calibrate pH	Fouled pH sensor	Clean sensor.
	Faulty pH sensor	Replace sensor.
Front Panel pH Feed LED Off And:	Limit timer timed out	Solve problems by solutions listed and limit timer will reset itself.
<ul style="list-style-type: none"> • pH Above Rising Set Point 		
<ul style="list-style-type: none"> • pH Below Falling Set Point 		
Front Panel pH Feed LED Stays On	Restriction in sample line	Check for flow in sample stream and:
		<ul style="list-style-type: none"> • Clean strainer.
		<ul style="list-style-type: none"> • Clean sample line.
	Pump lost prime	Prime pump.
	Chemical drum empty	Replenish chemical supply.
		Reset Timer:
		1) Interrupt flow through flow assembly if installed
		2) Satisfy the condition by manually feeding, etc.

REINITIALIZATION

If the above troubleshooting steps fail to explain or solve condition, perform a factory reinitialization (see Initialization at page 9, and Diagram 7, Mother Board, page 32 Maintenance

11. MAINTENANCE

Maintenance on the PULSAtrol™ MCT 100 Series controller requires only that the operator periodically clean and calibrate the electrodes.

The controller is designed for factory maintenance only. There are no field serviceable parts. Service should be performed only by factory authorized service personnel. Modification to or

tampering with the circuit level components, makes all warranties, written or implied, and/or manufacturer's responsibility for this controller null and void.

Refer to Electrode/Probe Installation, page 6, for illustrations and more information.

!!CAUTION!!

Use proper handling procedures including rubber gloves, eye protection and protective clothing, when handling any acid solution.

!!WARNING!!

Solutions are very corrosive! Handle with extreme care.

CONDUCTIVITYELECTRODE INFORMATION

To remove electrode from its tee for cleaning, keep the following in mind:

Remove power from the system.

Remove pressure from the system prior to unscrewing the electrode. To remove pressure, close hand valves located before and after flow assembly.

Open the sample port. This will facilitate removal of electrode.

Unscrew the coupling nut.

Remove electrode. If necessary, assure slot on nut and dimples on electrode or electrode holder are NOT lined up. (Refer to Cleaning the Electrode below)

Reinsert electrode, conductivity electrodes are keyed.

Hand tighten nut.

Close sample port.

Reapply pressure and flow by opening hand valves slowly to avoid water hammer.

Reapply power to the system.

Cleaning the Conductivity Electrode

Wipe the electrodes clean with a clean cloth. Do not touch the stainless steel electrodes. Oils from your skin can alter readings.

Use a fine grain emery cloth for stubborn stains.

Some fouled electrodes might require dipping in a mild solution of muriatic acid in order to remove fouling.

PH PROBE INFORMATION

The combination pH probe supplied with your PULSAtrol is designed for maximum reliability, accuracy, and ease of use. The reference half-cell is sealed and non-refillable. The probe is shipped with a protective boot filled with a junction wetting agent.

A) Preparation

Remove the lower portion of the protective boot and rinse the probe tip with tap water. It is possible that air bubbles may have migrated into the pH sensitive bulb during shipment. The

probe is unable to function with air in the bulb. To remove air, gently shake the probe downward in the same manner as a clinical thermometer. Prior to first usage or after long-term storage, immerse the lower end of the probe in tap water for thirty minutes. This hydrates the pH bulb and prepares the liquid junction for contact with the test solution.

Occasionally during long-term storage or shipment, the probe may develop a film on the pH bulb. The film may be removed by following probe cleaning instructions.

B) Probe Storage

To maintain response, probes should always remain wet. The preferred storage solution is pH 4.0 buffer with saturated KCl added. Tap water will suffice for short term storage. NOTE: Do not soak in distilled water. The storage boot will provide an ideal chamber for lengthy storage.

C) Probe Cleaning

Probes which are mechanically intact can often be restored to full response by the following procedures:

Inorganic Scale Deposits. Dissolve the deposit by immersing the probe first in 0.1M HCl, then in 0.1M NaOH, and again in 0.1M HCl. Each immersion should be for a 5-minute period.

Organic Oil or Grease Films. Wash probe tip in a liquid detergent and water. If film is known to be soluble in a particular organic solvent, wash with this solvent. Rinse probe tip in tap water.

If these procedures fail to rejuvenate the probe, the problem is most likely a clogged liquid junction. Cleaning the liquid junction involves heating a diluted KCl solution to 60-80C. Place probe tip in the heated KCl solution for approximately ten minutes. Allow the probe to cool while immersed in the solution before re-testing. If these steps fail to improve the probe response, replace the probe.

D) ORP Maintenance and Troubleshooting

ORP standard buffers of 100mV and 465mV are readily available, making it easy to standardize ORP systems against buffers. Like pH sensors, ORP sensors are subjected to coating and abrasion by the measured liquid and, in certain instances, are "poisoned" by chemicals which may be present if the system goes out of control. To improve the reliability of ORP measurement and control, the following is a means of testing sensors in solutions of standard potential, which will determine if sensors are responding correctly or need maintenance attention.

1. Solution A: Use sufficient 100mV buffer to immerse sensors. Potential should be within +/-10.
2. Solution B: Remove sensors and rinse thoroughly with water. Immerse sensors in 465mV solution. There should be a rapid response.

The millivolt difference between the two solutions is theoretically 365mV. The absolute values may shift upward or downward a few millivolts due to slight variations from theoretical potential by the reference sensor.

If system potentials are correct, flush sensors with deionized water and measure the liquid in question. If incorrect by more than 10mV, sensors should be cleaned with aqua regia (three volumes hydrochloric acid, one volume concentrated nitric acid.) Repeat above tests. Once satisfactory readings are obtained, install sensors and make measurements of liquid in question.

12. Glossary

Alarm Relay an electric circuit when triggered by a predetermined signal will activate an externally connected alarm

Analog a device that represents in terms of physical variables, i.e. conductivity, pH, ORP

Analog Recorder a device such as a plotter that physically stores or presents quantities of data in a physical manner

Auto Scroll a function of the Controller which allows unit to automatically display system status, active alarms, time, date, etc.

Biocide an agent used to control the growth of algae and other organic substances

Bleed (or blowdown) to release cooling tower water from the system, used to control conductivity

Blowdown see Bleed

Blowdown Valve the valve that opens or closes to release water from the system activated by a signal from the Controller

Buffer Solution a solution with a specific pH value used as a control in calibrating probes and sensors

Calibration a procedure to match values read by probes and sensors to actual real world values

Cal Kit a kit available from PULSAfeeder with a specific cavity volume used to calibrate conductivity sensor

Caustic burning, corrosive, a characteristic of some chemicals especially strong alkalis

Chattering a situation that occurs when relay controlled device repeatedly turns off and on

Chemical Feed Pump a relay or proportionally controlled pump that disperses chemical into the system

Chemical Metering Pump see Chemical Feed Pump

Conductivity the ability of a substance to conduct electrical current, concentrations of dissolved and suspended matter in cooling tower water directly determine the conductivity of the water

Configure procedure to set up basic functions of the controller, i.e. date, time, set point control, etc.

Contacting head water meter water meter

Dip Switch very small switches located on the circuit boards usually used in combination with other dip switch settings

Display Dampener a setting in the System Configure menu that determines the number of samples that are averaged and the number of seconds before a new reading is displayed on the screen

Double Junction type of construction on a pH probe

Dry Contact relay contacts without power

EEPROM Electrically Erasable Programmable Only Memory

Electrodes or sensors, the metal protrusions that measure conductivity in the conductivity sensor assembly

Fish Paper thin paper that is inserted between battery and battery clip to prevent battery drain during shipping or storage of controller

Float Switch a mechanical switch that shuts off fresh water supply to the cooling tower system when water level rises to a predetermined height

Flow refers to the movement of water through the system

Flow Assembly a PULSAfeeder option which attaches to the controller and incorporates a flow switch, sensor/probe ports, and sample valve

Gate Valve a type of on/off valve for controlling the flow of liquid

GFPP Glass Filled Polypropylene

Ground Loops unwanted stray electrical signals that adversely affect controller

Heat Exchanger a mechanical device which produces energy and is cooled by the flow of water in the cooling tower system

Hi LoAlarm a function of the controller that signals the user when conditions exceed a predetermined high or low value

History Files information that is stored in the controller, (history files are lost if battery fails or is removed)

HOA abbreviation for Hands Off Auto

HOA Switches manual relay switches or keys (relay 1 - 6) located on the control panel of the controller

Inhibitor Timer a function of the controller which regulates the amount of time inhibitor is introduced to the system

Initialization a procedure to set up the starting condition of the controller

Inorganic Scale Deposits undesirable precipitate formations within the cooling tower system

Inputs receptacles or hookups for signals delivered to the controller

(ISO) Isolation Valves general term which refers to valves in the system used to isolate various components of the system from the main flow

Jumper a wire connector (shunt) that connects two points

KCl Potassium Chloride

LED abbreviation for Light Emitting Diode

Limit Timer also referred to as lockout timer or feed limit timer, it limits the amount of time output is activated

Line Voltage voltage equivalent to outside source voltage to the controller

Lockout intentionally preventing blowdown or other functions of the system

Menu Map printed document supplied with controller illustrating all menu item locations

Metering Pump see chemical feed pump

Micro Siemens unit of measure of conductivity expressed as uS/cm

Mother Board main circuit board located in controller

NaOH Sodium Hydroxide

ORP Oxidation Reduction Potential, measured in milliVolts (mV) to detect and control level of chlorine or other oxidizing agents in system water

Outputs receptacles or hookups for signals originated at the controller

Overfeed a condition in which the quantity of an ingredient dispersed into the system exceeds the amount desired

Percent Post Blowdown refers to the amount of time as a percentage of blowdown time that chemical feed pumps are activated when blowdown is deactivated

Percent Timer also referred to as a cycle timer that runs continuously that activates an output to run as a percent of total cycle time

Program Parameters the user programmed settings that determine how the controller responds to the conditions of the cooling tower water

Pulse the action of a water meter that when equipped with a contact head, can generate a signal sent to the controller

Pulse Timer a feature of the controller in which a timer accepts pulses from a water meter to actuate a chemical feed pump

Relay Board a circuit board in the controller for relay outputs, water meter hookups, flow switch, etc.

Relay Indicators lights (LEDs) located beneath the relay keys on the face of the control panel that indicates the status of individual relays

Sample Cock see Sample Valve

Sample Line a line within the cooling tower flow where probes and other monitoring devices are located controlled with isolation valves

Sample Stream Flow Assembly a PULSAfeeder option (standard on many models) which is a modular assembly that mounts to the controller with quick-release probe(s), flow switch and sample cock or (valve)

Sample Valve small valve on the flow assembly that provides user a means to drain small quantities of water from the system for testing

Scale/Range the adjustable monitoring range of the controller in reference to conductivity levels in the system

Security Code a code that can be entered by the user when configuring the system to secure access to the controller settings

Sensors see Probe

Set Point the user determined value within a monitored range at which the controller initiates action

Set Point Differential also referred to as dead band or hysteresis; the offset applied to a set point to prevent chattering of an output relay around a set point

Solenoid an electromagnetically controlled switch

Storage Boot small protective rubber boot filled with a junction wetting agent found on the tip of a new pH or ORP probe to keep tip wet during shipment and storage

System Overfeed usually a malfunction condition where a feed pump fails shut off

System Parameters see program parameters

System pH level of pH in the system water

TDS abbreviation for Total Dissolved solids, measured in terms of electrical conductivity (u/Scm)

Temperature Compensation displays conductivity as if measured at 25oC

Temp Sensor used to measure temperature, not currently available on MCT series

Throttling the act of adjusting a valve or other flow control device to vary flow volume

Totalizer a resettable function of the controller which keeps count of the number of water meter pulses

Track Set Point a function of the controller in which set point offset range is determined by set point value

uS/cm micro Siemens

Water Hammer a potentially damaging situation that occurs if a valve in the system is opened to quickly, where the action results in a “hammering” effect throughout the system water lines

Y-Strainer inline filter or screen to remove debris from system flow assembly

13. Index

14. Other Models in MCT Series w/Options

Series	Standard Features	Available for Options					
		Analog In	Digital In	Analog Out	Dry Contact	Relay Output	Serial Comm.
110	Conductivity control with Hi/Lo alarm indicator	0	1	1	1	1	0
120	pH Control with Hi/Lo alarm and limit timer	0	1	1	1	1	0

130	ORP Control with Hi/Lo alarm and limit timer	0	1	1	1	1	0
210	Conductivity control with Hi/Lo alarm indicator	1	2	2	1	3	1
220	pH Control with Hi/Lo alarm and limit timer and flow assembly	1	2	2	1	3	1
230	Conductivity and pH control with flow assembly Conductivity - Hi/Lo alarm indicator and selectable timer pH – Hi/Lo alarm indicator and limit timer	0	1	2	1	1	1
310	Conductivity control with Hi/Lo alarm indicator, alarm relay, and selectable timer	3	2	2	1	4	1
320	pH control with Hi/Lo alarm indicator, alarm relay, limit timer and flow assembly	3	3	2	1	5	1
330	Conductivity and pH control with flow assembly Conductivity – Hi/Lo alarm indicator, alarm relay, and selectable timer pH – Hi/Lo alarm indicator and limit timer	2	2	2	1	3	1

Option	Series	Analog In	Digital In	Analog Out	Dry Contact	Relay Output	Serial Comm.
A – Conduit	100/200/300						
B - Mounted flow assembly	100/200/300						
C – Selectable timer: percent, limit or pulse with accumulator	100/200/300		1			1	
D – Alarm output relay (Series 100 requires relay out)	100/200						
E – 28 day single biocide with bleed lock-out and pre-bleed	100/200/300					1	

F - 28 day dual biocide with bleed lock-out and pre-bleed	200/300					2	
G - 28 day triple biocide with bleed lock-out and pre-bleed	200/300					3	
H – Make up water conductivity (require conductivity control)	200/300	1					
I – ORP (available with pH only)	200/300	1				1	
K – Alarm dry contact (Series 100 requires relay out)	100/200/300				1		
L-1 – Serial line communications with software	200/300						1
L-2 - Serial line communications with software and modem	200/300						1
M-1 – 0-1 mA recorder output, linear	100/200/300			1			
M-2 – 4-20 mA recorder output, linear	100/200/300			1			
M-3 – 4-20 mA isolated programmable proportional output	100/200/300			1			
P – 220VAC at 50/60Hz service (requires option A)	100 (only)						

15. Biocide Programming Worksheet

(Please make copies of this sheet for future use)

CHEMICAL NAME

BIOCIDE

PROGRAM #1

Week

Day

Start Time:____:____H:M

PROGRAM #2

Week Day
Start Time:____:____H:M

PROGRAM #3

Week Day
Start Time: :____:____H:M

PROGRAM #4

Week Day
Start Time: :____:____H:M

Biocide	Run Time	Time: ____:____H:M
Biocide	Pre-Bleed Time	Time: ____:____H:M
Biocide	Pre-Bleed Min Conductivity	Time: ____:____H:M
Biocide	Bleed Lock-Out	Time: ____:____H:M

Make Copies and Repeat For Each Biocide

PULSAFEEDER
ELECTRONIC CONTROL OPERATIONS
27101 AIRPORT RD
PUNTA GORDA, FL 33982
1-800-333-6677 / FAX 1-800-456-4085

NOVA-TECH
INTERNATIONAL
800 Rockmead Dr Ste 102 • Houston, TX 77339-2496
Tel: (281) 359-8538 • Toll Free Tel: (866) 433-6682
Fax: (281) 359-0084 • Toll Free Fax: (866) 433-6684
sales@novatech-usa.com • www.novatech-usa.com

NOVA-TECH
INTERNATIONAL
800 Rockmead Dr Ste 102 • Houston, TX 77339-2496
Tel: (281) 359-8538 • Toll Free Tel: (866) 433-6682
Fax: (281) 359-0084 • Toll Free Fax: (866) 433-6684
sales@novatech-usa.com • www.novatech-usa.com