

FabiaTech Corporation

IPC Solution

Website: <http://www.fabiatech.com>

Email: support@fabiatech.com

PC104 CPU Board
Low Power Series
FB2412 User's Manual

OCT 2009
Version: 1.0
Part Number: FB2412

Copyright

Copyright © 2009 FabiaTech Corporation, The content of this publication may not be reproduced in any part or as a whole, transcribed, stored in a retrieval system, translated into any language, or transcribed in any form or by any means, electronic, mechanical, and magnetic... or otherwise without the prior written permission of FabiaTech Corporation.

Disclaimer

FabiaTech makes no representation of warranties with respect to the contents of this publication. In an effort to continuously improve the product and add features, FabiaTech reserves the right to revise the publication or change specifications contained in it from time to time without prior notice of any kind from time to time.

FabiaTech shall not be reliable for technical or editorial errors or omissions, which may occur in this document. FabiaTech shall not be reliable for any indirect, special, incidental or consequential damages resulting from the furnishing, performance, or use of this document.

Trademarks

Trademarks, brand names and products names mentioned in this publication are used for identification purpose only and are the properties of their respective owners.

Technical Support

If you have problems or difficulties in using the system or setting up the relevant devices, and software that are not explained in this manual, please contact our service engineer for service, or send email to support@fabiatech.com.

Returning Your Board for Service & Technical Support

If your board requires servicing, contact the dealer from whom you purchased the product for service information. You can help assure efficient servicing of your product by following these guidelines:

- ❑ A list of your name, address, telephone, facsimile number, or email address where you may be reached during the day
- ❑ Description of you peripheral attachments
- ❑ Description of your software (operating system, version, application software, etc.) and BIOS configuration
- ❑ Description of the symptoms (Extract wording any message)

For updated BIOS, drivers, manuals, or product information, please visit us at www.fabiatech.com

Table of Contents

FB2412 User's Manual	i
Chapter 1 Introducing the FB2412 System	1
Overview.....	1
Layout.....	2
Specifications.....	3
Packing List	4
Chapter 2 Hardware Installation	5
Before Installation	5
Hardware Features.....	6
CN6: Power Connector (4-pin 2.5mm JST).....	7
J5: Reset Header	7
J6: RJ45 LAN /Adapter Connector with LED indicators	8
J4: Keyboard/Mouse Connector	9
J3: External Speaker Header	9
J1: USB Connector	10
LED1/JP2: Power LED indicator, External HDD LED Header	10
CN3 & CN4: RS232 Serial Port Connectors	11
BT1 (Battery): Clear CMOS Data	12
CN5: TTL I/O Connector	12
CF1 & JP1: Compact Flash Socket and Master/Slave Select.....	13
CN1: IDE hard Disk Connector.....	14
BUS1: PC/104 Bus Connectors.....	15
Chapter 3 Installing CRT Display	17
CRT Display (CN7).....	17
Chapter 4 BIOS Setup	19
Overview.....	19
BIOS Functions	20
Keyboard Convention	21
Main Setup	22
Advanced Setup.....	23
CPU Configuration.....	24

IDE Configuration.....	25
Remote Access Configuration	27
USB Configuration	29
PCIPnP Setup.....	30
Boot Setup	32
Boot Setting Configuration.....	33
Boot Device	35
Hard Disk Drives	35
Removable Drives.....	35
Security setup.....	36
Chipset Setup.....	38
Northbridge Configuration.....	39
Southbridge Configuration.....	42
Chapter 5 Driver and Utility.....	47
VGA Drivers	47
WINDOWS Driver	47
LAN Utility & Driver	48
BIOS Flash Utility.....	48
Watchdog Timer	49
Watchdog Timer Setting	49
Setup Watchdog Timer Step - WDT0 and WDT1	51
Chapter 6 Technical Reference	55
Trouble Shooting for Post Beep and Error Messages.....	55
POST BEEP	55
Error Message	55
Technical Reference.....	58
Physical and Environmental	58
Real-Time Clock and Non-Volatile RAM	58
CMOS RAM Map.....	60
I/O Port Address Map.....	61
Interrupt Request Lines (IRQ)	62
Serial Ports	63
Appendix.....	67

Dimension67

Chapter 1 Introducing the FB2412 System

Overview

The FB2412 is a Vortex86DX Low power processor, all in one PC/104 CPU board. This user's manual provides information on the physical features, installation, and BIOS setup.

Built to unleash the total potential of the Vortex86DX Processor, the FB2412 is a single board computer capable of handling today's demanding requirements. Able to support 800 MHz CPU, this unit supports 10/100M interface network port, on board 128MB DDR2 RAM, two USB2.0 ports, and a SMI SM712 VGA controller.

Each FB2412 has two ports for I/O communications. One RS232 and one RS-232 /RS485 ports are available. There are supports 2 watchdog timers that can be configured from software to automatically reset the system. And for easy configuration, AMI BIOS are available.

The FB2412 is perfect for POS and POI applications, network systems, panel / MMI's, order entry kiosks, test equipment, and OEM projects. The unit is only 90.2x95.9mm, offering unparalleled performance in a very small footprint.

Specifications

- ❑ Vortex86DX (800MHz) Low Power CPU.
- ❑ Onboard 128MB DDR2 RAM.
- ❑ One Realtek 8100C 10M/100M Base-TX Ethernet port.
- ❑ SMI SM712 VGA Controller support VGA port.
- ❑ Two RS-232 ports, one RS232 port and one RS232/RS485 port.
- ❑ Two USB (V2.0) ports, and one PCI IDE interface.
- ❑ Compact Flash socket for 3.3V Compact Flash and Micro Drives.
- ❑ PS/2 compatible keyboard and mouse interface.
- ❑ Providing header for external speaker and hard disk access LED.
- ❑ Two Watchdog timer and easy software programmable watchdog timer.
- ❑ Flash BIOS with easy upgrade utility.
- ❑ PC/104 form factor, 90.2 mm x 95.9 mm (3.55" x 3.775")
- ❑ Power requirement: +5V only, 3.0A maximum. (800MHz CPU)

Packing List

Upon receiving the package, verify the following things. If any of the mentioned happens, contact us for immediate service.

- Unpack and inspect the FB2412 package for possible damage that may occur during the delivery process.
- Verify the accessories in the package according to the packing list and see if there is anything missing or incorrect package is included.
- If the cable(s) you use to install the FB2412 is not supplied from us, please make sure the specification of the cable(s) is compatible with the FB2412 system.

Note: After FB2412 is installed, it is recommended that you keep the diskette or CD that contains drivers and document files, and keep the document copies, or unused cables in the carton for future use.

The following list the accessories that may be included in your FB2412 package. Some of the accessories are optional shipped only upon order.

- One FB2412 All-In-One PC/104 CPU board.
- One VGA (CRT interface) adapter cable.
- Two serial port adapter cables.
- One PS2 keyboard and mouse port adapter cable.
- One 10-pin LAN adapter cable with FB4605A board.
- One compact disc containing manual file in PDF format and necessary drivers and utilities.

Chapter 2 Hardware Installation

This chapter introduces the system connectors & jumper settings, and guides you to apply them for field application.

Before Installation

Before you install the system, make sure you follow the below descriptions.

1. Before removing the board from its anti-static bag, wear an anti-static strap to prevent the generation of Electricity Static Discharge (ESD). The ESD may be generated by man's physical touch. It may do damage to the board circuit.
2. Install any connector, module, or add on board, be sure that the power is disconnected from the system board. If not, this may damage the system board components, module, or the add-on-board.
3. When you connect the connectors and memory modules, be careful with the pin orientations.

Hardware Features

The following list is for the setup of the connectors and jumpers of the FB2412.

Item	Description
CN1	44-pin 2.0mm IDE 2 hard disk connector (IDC)
CN3, CN4	10-pin 2.0mm RS-232 port connector (IDC)
CN5	5-pin 2.54 mm TTL IO connector 40-pin
CN6	4-pin Power connector
CN7	10-pin 2.0mm CRT connector (IDC)
CF1,JP1	Compact Flash Socket and CF Master/Slave Select
J1	10-pin USB connector header
J3	2-pin for external speaker header
J4	6-pin for Keyboard and Mouse connector (JST)
J5	2-pin Reset header
J6	10-pin header for RJ45-Lan adapter
JP2	2-pin header for HDD LED indicator
JP3, JP4	3*3-pin header select RS232/RS485 port
JP5	3-pin RS485 (COM2) Terminal Resistor Jumper Select
LED1	Power and watchdog of LED indicator
BUS1	PC-104 Connector

□ **CN6: Power Connector (4-pin 2.5mm JST)**

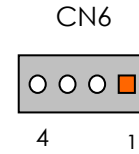
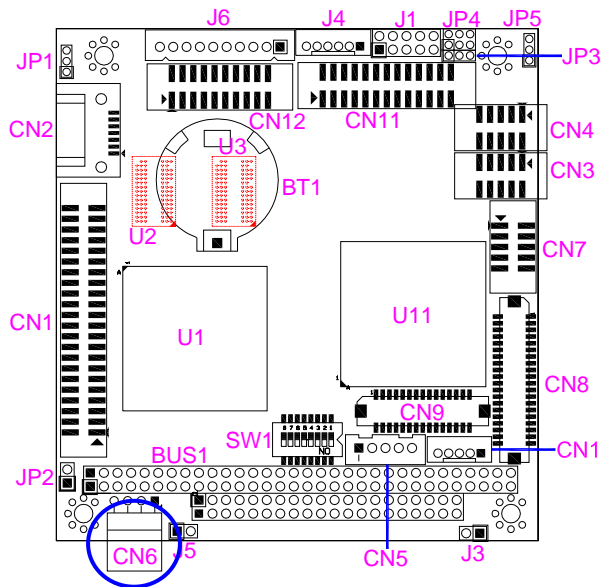

PIN	Signal
1	VCC (+5V)
2	Ground
3	Ground
4	VDD (+12V)

Note: FB2412 needs +5V only, +12V is not necessary.

Note: Be careful with the pin orientation when installing power connector. A wrong connection can easily destroy your FB2412 board.

□ **J5: Reset Header**

J5 is a 2-pin header for connecting to system reset button. Shorting the circuit of the 2 pins makes the hardware reset and FB2412 restart system. It is similar to power off the system and then power it on again.

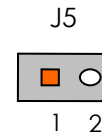
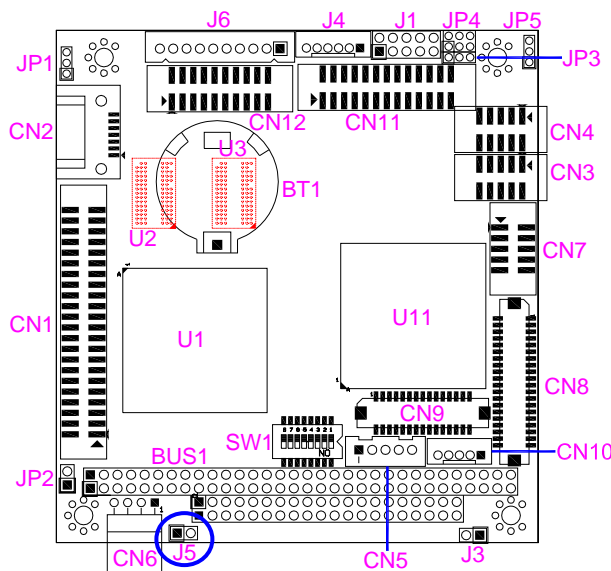

PIN	Signal
1	Reset +
2	Reset -

□ **J6: RJ45 LAN /Adapter Connector with LED indicators**

FB4605A is a RJ45 connector with 2 LEDs for LAN. The left side LED (orange) indicates data which is being accessed and the right side LED (green) indicates on-line status. (On indicates on-line and Off indicates off-line) J6 provides twist-pair signals of LAN port if you got LAN version and adapter board (FB4605A) with cable. The following lists the pin assignments of J6 to RJ45 connector on the FB4605A LAN adapter board:

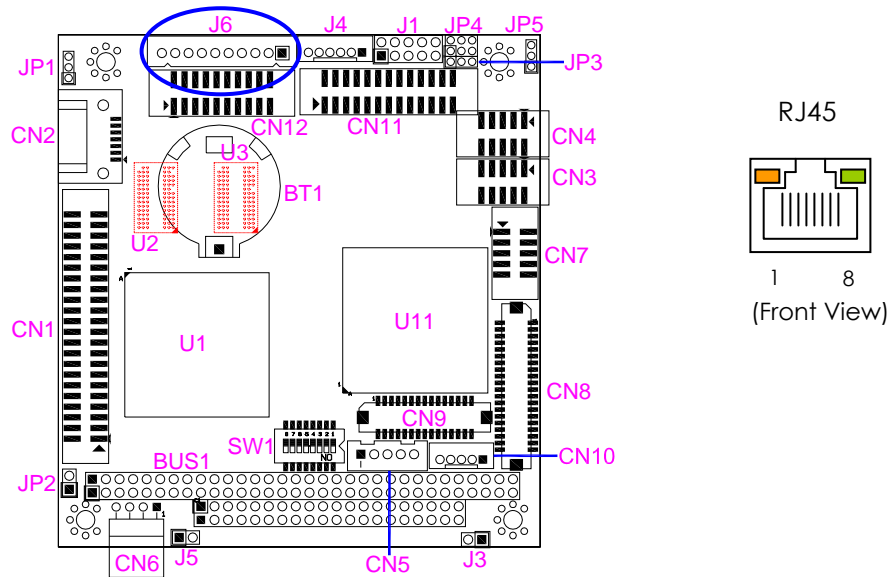

The following list the pin assignments of J6.

J6	Signal	RJ45	J6	Signal	RJ45
1	TPTX+	1	6	Access LED	-
2	TPTX -	2	7	On-Line LED	-
3	TPRX+	3	8	Case GND	-
4	TPRX -	6	9	FBG1	4
5	LED Common	-		FBG1	5
				FBG2	7
			10	FBG2	8

□ **J4: Keyboard/Mouse Connector**

J4 is a 6-pin 2.0mm JST connector, use the included KB/MS adapter cables you can attach standard PS/2 type keyboard and mouse.

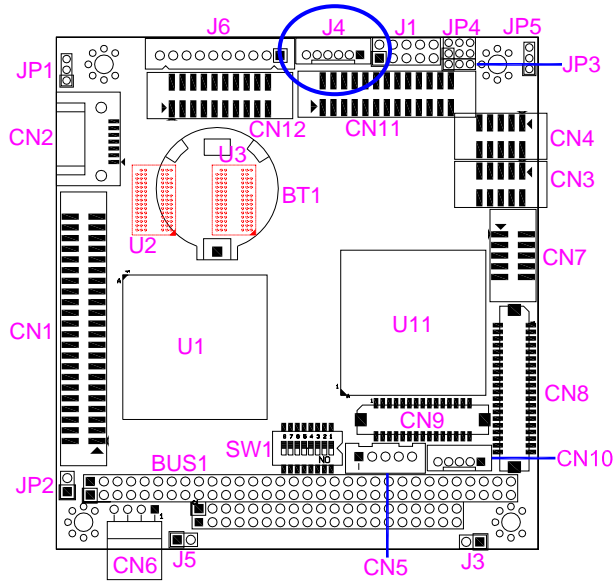

J4

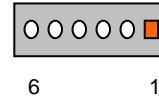

PIN	Signal
1	Mouse Data
2	Keyboard Data
3	Ground
4	VCC
5	Mouse Clock
6	Keyboard Clock

□ **J3: External Speaker Header**

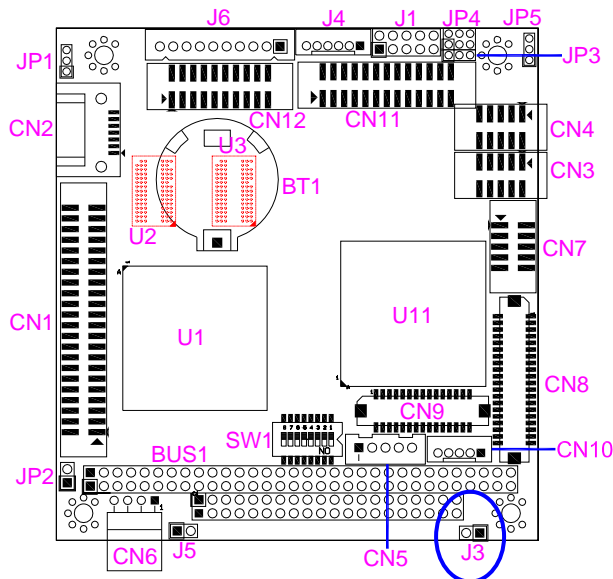

J3



PIN	Signal
1	Speaker+
2	Speaker-

□ **J1: USB Connector**

Use the USB adapter cable, you can attach up to 2 USB devices.

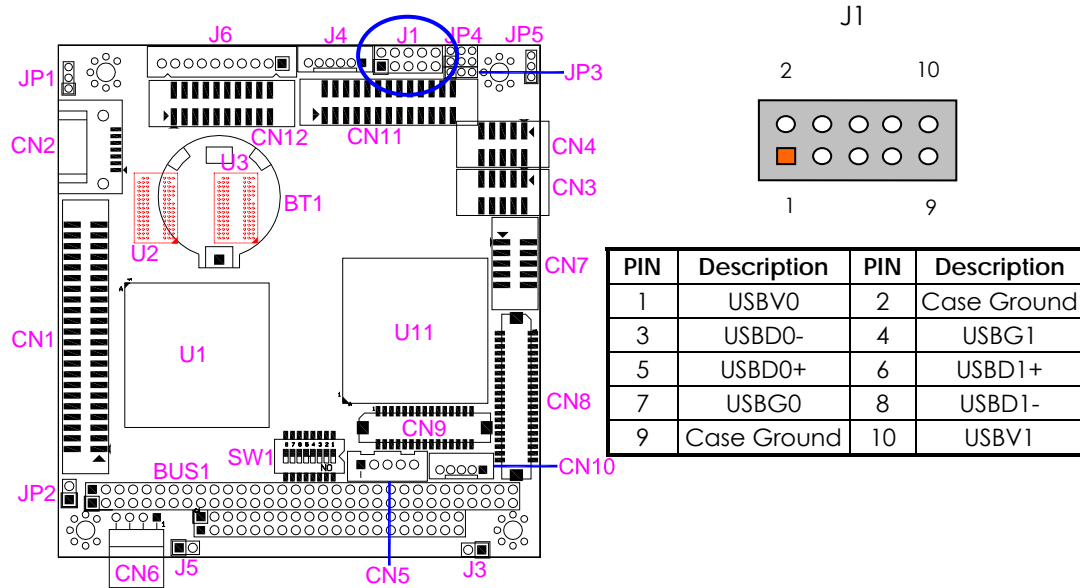

□ **LED1/JP2: Power LED indicator, External HDD LED Header**

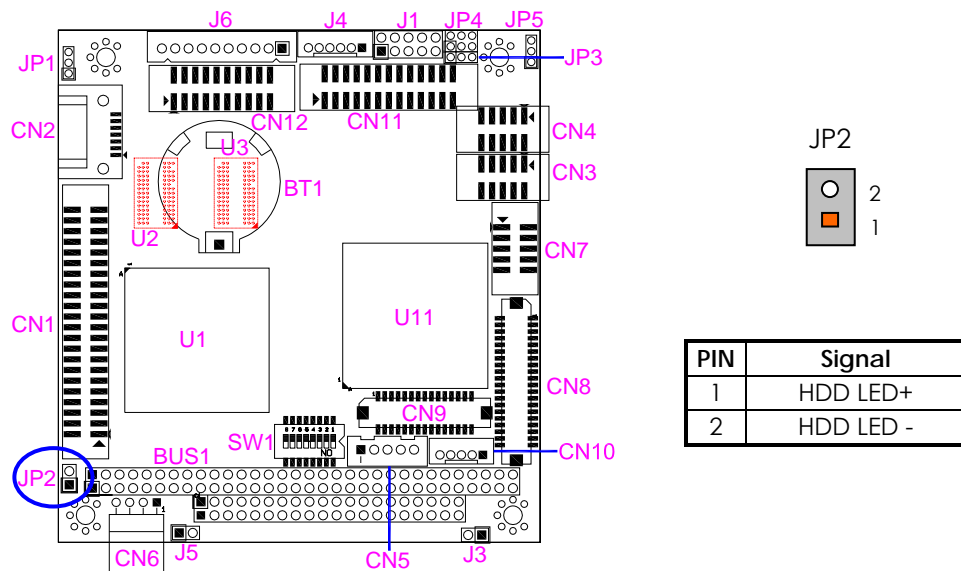

□ **CN3 & CN4: RS232 Serial Port Connectors**

CN3 (COM1) & CN4 (COM2) are 10-pin 2.0mm IDC connectors. The included serial port adapter cables are used to transfer 10-pin 2.0mm IDC into standard DB-9 connector. The following tables show the signal connections of these connectors and the included adapter cable for CN3 & CN4.

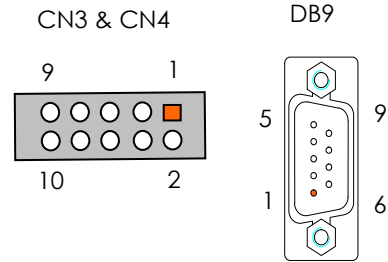
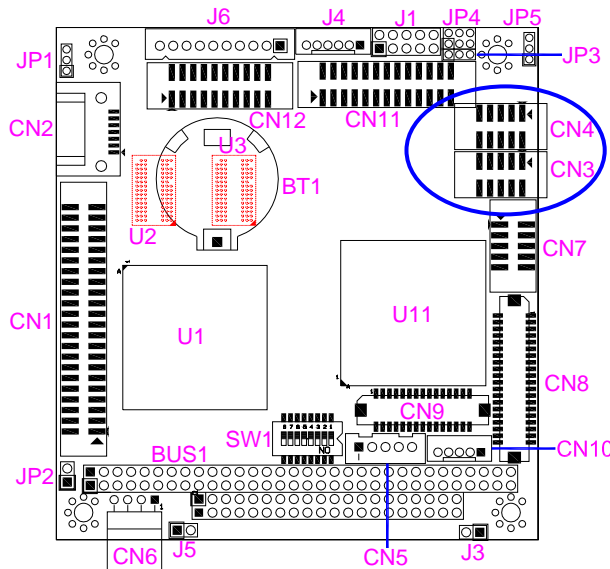

DB-9	RS-232	RS-485
1	-DCD	
6	-DSR	
2	RXD	485-
7	-RTS	
3	-TXD	485+
8	-CTS	
4	-DTR	
9	-RI	
5	Ground	
Metal	Case Ground	

➤ **JP3 & JP4: COM2 RS232/RS485 Selection**

The CN4-COM2 is designed for multiple purposes. The following tables show the signal connections of these connectors. Use JP3, JP4 and JP5 can select the RS-232 or RS-485.

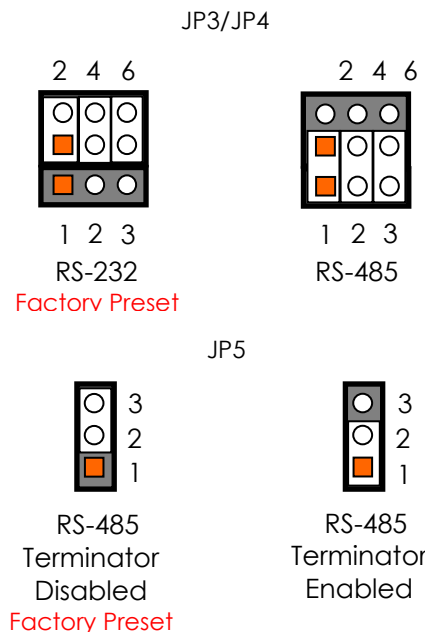
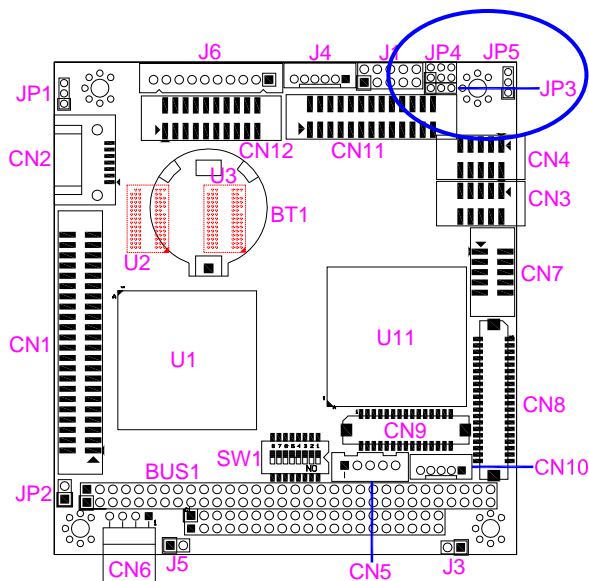

□ **BT1 (Battery): Clear CMOS Data**

You can remove the battery from BT1 socket to clear CMOS data. The CMOS stores information like system date, time, boot up device, password, IRQ... which are set up with the BIOS. To clear the CMOS, remove the battery about the 3 sec and then return the battery to BT1 socket before when system powers is off.

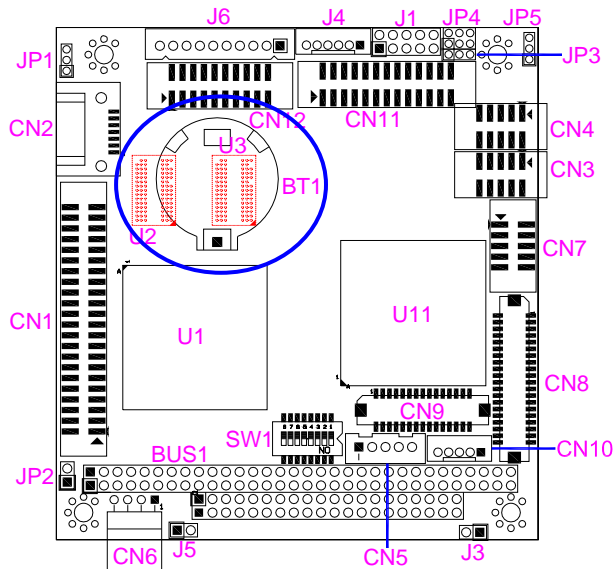

□ **CN5: TTL I/O Connector**

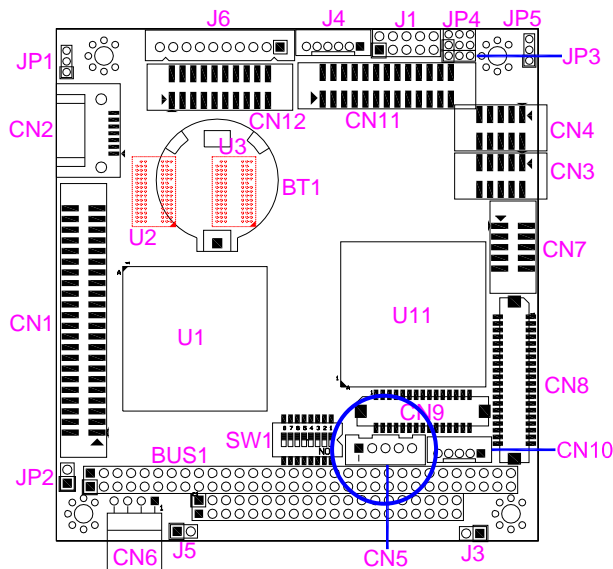

CN5

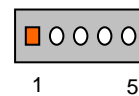

Pin	TTL Lines	Bit Location
1	Output Line 0	Bit 0 of 78h
2	Output Line 1	Bit 1 of 78h
3	Input Line 0	Bit 0 of 79h
4	Input Line 1	Bit 1 of 79h
5	Ground	-

□ **CF1 & JP1: Compact Flash Socket and Master/Slave Select**

The Compact Flash socket CF1 (on the solder side) is optional and supports 3.3V Compact Flash and Micro Drives. JP1 (on the top side) is used to select master/slave device of this socket.

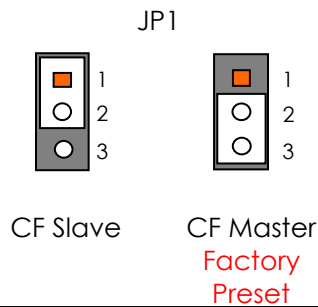
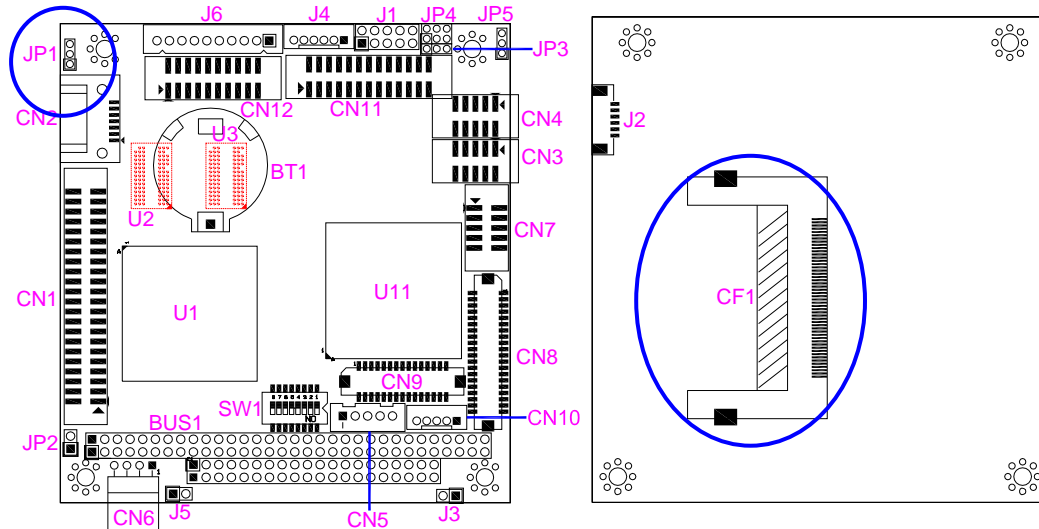

Note: The Compact Flash socket supports 3.3V Compact Flash and Micro Drives. The JP1 is used to select master/slave device of this socket and the default is Master (close).

□ **CN1: IDE hard Disk Connector**

CN1 is 44-pin 2.0mm IDC connectors. Use the included hard disk cables to attach up to two hard disk drives.

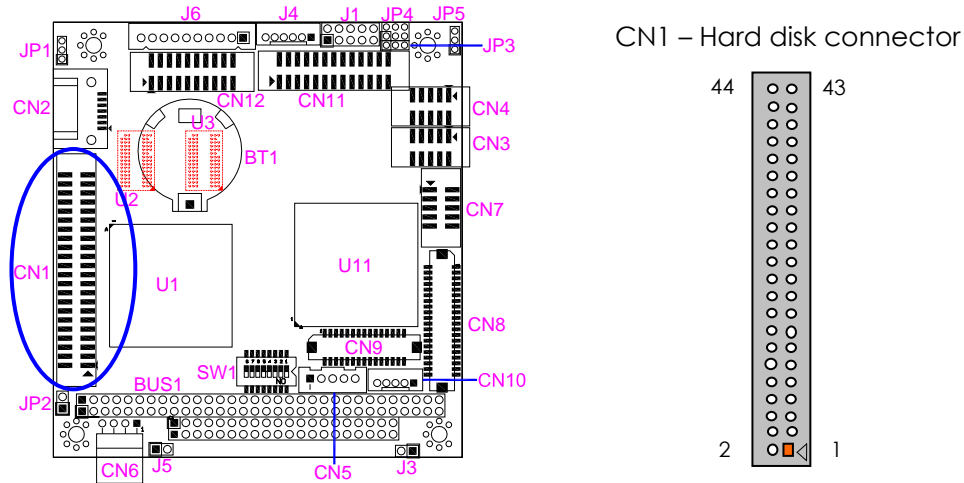

The following table lists the pin description of CN1.

Pin	Description	Pin	Description
1	-RESET	2	GROUND
3	DATA 7	4	DATA 8
5	DATA 6	6	DATA 9
7	DATA 5	8	DATA 10
9	DATA 4	10	DATA 11
11	DATA 3	12	DATA 12
13	DATA 2	14	DATA 13
15	DATA 1	16	DATA 14
17	DATA 0	18	DATA 15
19	GROUND	20	NOT USED
21	IDEDREQ	22	GROUND
23	-IOW A	24	GROUND
25	-IOR A	26	GROUND
27	IDEIORDYA	28	GROUND
29	-DACKA	30	GROUND
31	AINT	32	GROUND
33	SA 1	34	Not Used
35	SA 0	36	SA 2
37	CS 0	38	CS 1
39	HD LED A	40	GROUND
41	VCC	42	VCC
43	GROUND	44	Not Used

Note: Be careful with the pin orientation when installing connectors and the cables. A wrong connection can easily destroy your hard disk. CN1 is used to connect a 2.5" HDD with included 44-pin flat-cable or 44-pin DiskOnModule directly.

□ **BUS1: PC/104 Bus Connectors**

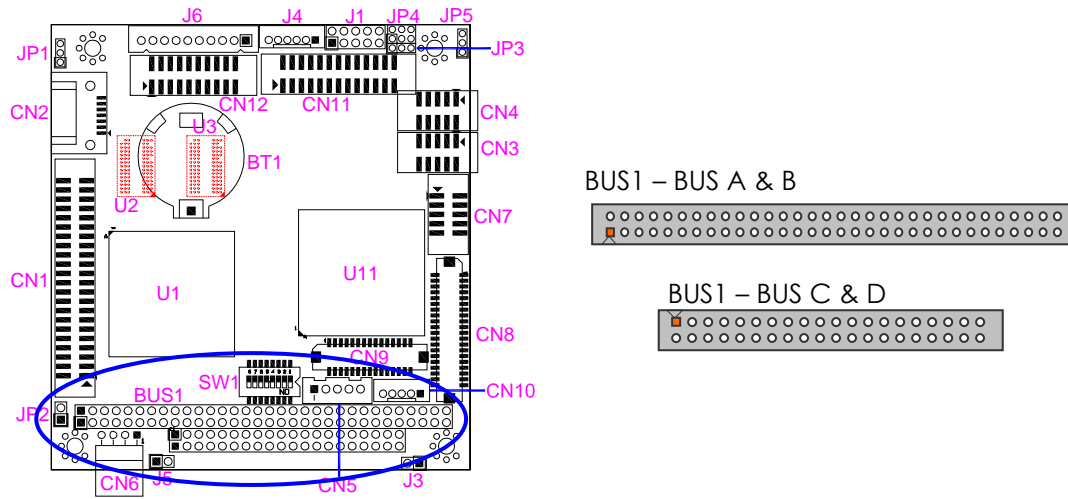

PC/104 A & B Pin

Pin	Signal	Pin	Signal	Pin	Signal	Pin	Signal
A1	-IOCHK	A17	SA14	B1	Ground	B17	-DACK1
A2	SD7	A18	SA13	B2	RSTDRV	B18	DRQ1
A3	SD6	A19	SA12	B3	+5V	B19	-Refresh
A4	SD5	A20	SA11	B4	IRQ9	B20	BUSCLK
A5	SD4	A21	SA10	B5	*(-5V)	B21	IRQ7
A6	SD3	A22	SA9	B6	DRQ2	B22	IRQ6
A7	SD2	A23	SA8	B7	*(-12V)	B23	IRQ5
A8	SD1	A24	SA7	B8	-ZWS	B24	IRQ4
A9	SD0	A25	SA6	B9	+12V	B25	IRQ3
A10	IORDY	A26	SA5	B10	KEY	B26	-DACK2
A11	AEN	A27	SA4	B11	-SMEMW	B27	TC
A12	SA19	A28	SA3	B12	-SMEMR	B28	ALE
A13	SA18	A29	SA2	B13	-IOW	B29	+5V
A14	SA17	A30	SA1	B14	-IOR	B30	OSC
A15	SA16	A31	SA0	B15	-DACK3	B31	Ground
A16	SA15	A32	Ground	B16	DRQ3	B32	Ground

PC/104 C & D Pin

Pin	Signal	Pin	Signal	Pin	Signal	Pin	Signal
C1	GND	C11	MEMW#	D1	Ground	D11	-DACK#5
C2	SBHE	C12	SD8	D2	MEMCS16#	D12	DREQ5
C3	LA23	C13	SD9	D3	IOCS16#	D13	DACK#6
C4	LA22	C24	SD10	D4	IRQ10	D14	DREQ6
C5	LA21	C25	SD11	D5	IRQ11	D15	DACK#7
C6	LA20	C26	SD12	D6	IRQ12	D16	DREQ7
C7	LA19	C27	SD13	D7	IRQ15	D17	VCC
C8	LA18	C28	SD14	D8	IRQ14	D18	Master#
C9	LA17	C29	SD15	D9	DACK#0	D19	GND
C10	MEMR#	C20	KEY	D10	DREQ0	D20	GND

Chapter 3 Installing CRT Display

This chapter describes the configuration and installation procedure of CRT displays.

CRT Display (CN7)

The FB2412 supports a CRT colored monitor. It can be connected to create a compact video solution for the industrial environment. 4MB simulated VRAM allows a maximum CRT resolution of 1280X1024 with 64K colors resolution of 1024X768 with 64K colors. The following table and figure illustrate the pin definition of CN7 and D-sub 15-pin on the CRT adapter cable:

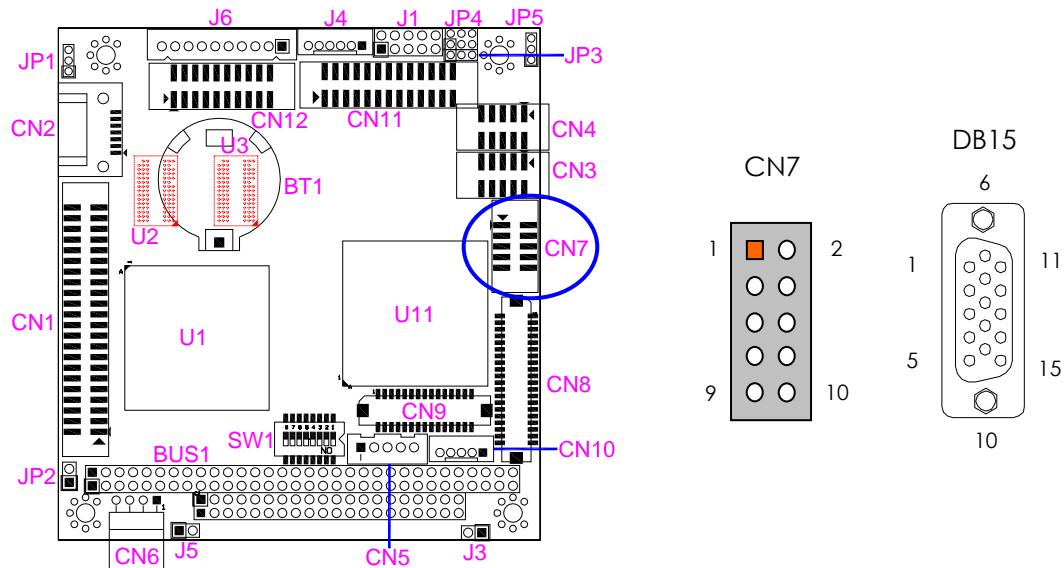

Pin	Signal	DB-15	Pin	Signal	DB15
1	RED	1	2	Case Ground	Case
3	GREEN	2	4	Digital Ground	5,10
5	BLUE	3	6	Analog Ground	6,7,8
7	VSYNC	14	8	DDC Data	12
9	HSYNC	13	10	DDC Clock	15

Chapter 4 BIOS Setup

This chapter describes the BIOS setup.

Overview

BIOS are a program located on a Flash memory chip on a circuit board. It is used to initialize and set up the I/O peripherals and interface cards of the system, which includes time, date, hard disk drive, the ISA bus and connected devices such as the video display, diskette drive, and the keyboard. This program will not be lost when you turn off the system.

The BIOS provides a menu-driven interface to the console subsystem. The console subsystem contains special software, called firmware that interacts directly with the hardware components and facilitates interaction between the system hardware and the operating system.

The BIOS default values ensure that the system will function at its normal capability. In the worst situation the user may have corrupted the original settings set by the manufacturer.

All the changes you make will be saved in the system RAM and will not be lost after power-off.

When you start the system, the BIOS will perform a self-diagnostics test called Power On Self Test (POST) for all the attached devices, accessories, and the system. Press the [Del] key to enter the BIOS Setup program, and then the main menu will show on the screen.

Note: Change the parameters when you fully understand their functions and subsequence.

```

Main   Advanced  PCIPnP  Boot   Security  Chipset  Exit
*****
* Exit Options                                     * Exit system setup
* ****                                           * after saving the
* Save Changes and Exit                          * changes.
* Discard Changes and Exit                       *
* Discard Changes                               * F10 key can be used
*                                             * for this operation.
* Load Optimal Defaults                         *
* Load Failsafe Defaults                       *
*                                             *
*                                             *
*                                             *
* *      Select Screen
* **     Select Item
* Enter  Go to Sub Screen
* F1     General Help
* F10    Save and Exit
* ESC    Exit
*
*
*****
v02.67 (C)Copyright 1985-2009, American Megatrends, Inc.

```

□ BIOS Functions

On the menu, you can perform the following functions

1. Main
2. Advanced
 - CPU Configuration
 - IDE Configuration
 - Remote Access Configuration
 - USB Configuration
3. PCIPnP
4. Boot
 - Boot Settings Configuration
 - Boot Device Priority
 - Hard Disk Drives
 - CD/DVD Drivers
5. Security
 - Change Supervisor Password
 - Change User Password
 - Clear User Password
 - Boot Sector Virus Protection
6. Chipset
 - NorthBridge Configuration
 - SouthBridge Configuration
7. Exit
 - Save Changes and Exit: Exit system setup after saving the changes.F10 key can be used for this operation.
 - Discard Changes and Exit: Exit system setup without saving any changes. ESC key can be used for this operation.
 - Discard Changes: Discard changes down so far any of the set questions. F7 key can be used this operation.

- Load Optimized Default: to auto configure the system according to optimal setting with pre-defined values. This is also the factory default setting of the system when you receive the board.
- Load Fail-Safe Default: to configure the system in fail-safe mode with predefined values.

□ **Keyboard Convention**

On the BIOS, the following keys can be used to operate and manage the menu:

Item	Function
ESC	To exit the current menu or message
Page Up/Page Down	To select a parameter
F1	To display the help menu if you do not know the purpose or function of the item you are going to configure
F8	Fail-Safe Default
F9	Optimized Default
F10	Save and exit
UP/Down Arrow Keys	To go upward or downward to the desired item

Main Setup

This section describes basic system hardware configuration, system clock setup and BIOS version information. If the CPU board is already installed in a working system, you will not need to select this option anymore.

```

Main  Advanced  PCIPnP  Boot  Security  Chipset  Exit
*****
* System Overview                               * Use [ENTER], [TAB]
*                               * or [SHIFT-TAB] to
*                               * select a field.
* AMIBIOS                                       *
* Version   :08.00.15                          *
* Build Date:10/07/09                          *
* ID        :FB241200                          *
*                               * Use [+] or [-] to
*                               * configure system Time.
*                               *
* Processor                               *
* Vortex86DX A9121                           *
* Speed     :800MHz                            *
* Count     :1                                 *
*                               *
* System Memory                               * *   Select Screen
* Size      :128MB                             * **  Select Item
*                               * +-  Change Field
* System Time                               * Tab Select Field
* System Date                               * F1  General Help
*                               * F10 Save and Exit
*                               * ESC Exit
*                               *
*****
v02.67 (C)Copyright 1985-2009, American Megatrends, Inc.

```

➤ **System Memory**

This option is display-only which is determined by POST (Power On Self Test) of the BIOS.

➤ **System Date & Time Setup**

Highlight the <Date> field and then press the [Page Up] / [Page Down] or [+/] [-] keys to set the current date. Follow the month, day and year format.

Highlight the <Time> field and then press the [Page Up] / [Page Down] or [+/] [-] keys to set the current date. Follow the hour, minute and second format.

The user can bypass the date and time prompts by creating an AUTOEXEC.BAT file. For information on how to create this file, please refer to the MS-DOS manual.

Advanced Setup

Select the *Advanced* tab from the setup screen to enter the Advanced BIOS Setup screen. You can select any of the items in the left frame of the screen, such as IDE Configuration, to go to the sub menu for that item. You can display an Advanced BIOS Setup option by highlighting it using the <Arrow> keys. All Advanced BIOS Setup options are described in this section. The Advanced BIOS Setup screen is shown below. The sub menus are described on the following pages

```

Main  Advanced  PCIPnP  Boot  Security  Chipset  Exit
*****
* Advanced Settings                                     * Configure CPU.
* *****
* WARNING: Setting wrong values in below sections    *
*           may cause system to malfunction.          *
*
* * CPU Configuration                                  *
* * IDE Configuration                                 *
* * Remote Access Configuration                       *
* * USB Configuration                                 *
*
*
*
*
*
*
*
* *          Select Screen
* **         Select Item
* Enter     Go to Sub Screen
* F1       General Help
* F10     Save and Exit
* ESC     Exit
*
*
*****
v02.67 (C)Copyright 1985-2009, American Megatrends, Inc.

```

□ CPU Configuration

You can use this screen to select options for the CPU information. Use the up and down <Arrow> keys to select an item. Use the <Plus> and <Minus> keys to change the value of the selected option.

Note: The CPU Configuration setup screen varies depending on the installed processor.

```

Advanced
*****
* CPU Configuration                               * Options
* Module Version - 00.01                          *
* *****                                         * Disabled
* Manufacturer: DMP                               * Enabled
* Brand String: Vortex86DX A9121                  *
* Frequency   : 800MHz                             *
*                                                     *
* L1 Cache           [Enabled]                    *
* Cache L1           : 16 KB                       *
* L2 Cache           [Enabled]                    *
* Cache L2           : 256 KB                      *
*                                                     *
*                                                     *
* * Select Screen                                *
* ** Select Item                                 *
* +- Change Option                               *
* F1 General Help                               *
* F10 Save and Exit                             *
* ESC Exit                                       *
*                                                     *
*****
v02.67 (C)Copyright 1985-2009, American Megatrends, Inc.

```

❑ **IDE Configuration**

You can use this screen to select options for the IDE Configuration Settings. Use the up and down <Arrow> keys to select an item. Use the <Plus> and <Minus> keys to change the value of the selected option. A description of the selected item appears on the right side of the screen. The settings are described on the following pages. An example of the *IDE Configuration* screen is shown below.

```

Advanced
*****
* IDE Configuration
*****
* OnBoard PCI IDE Controller      [Both]
*
* * Primary IDE Master           : [Not Detected]
* * Primary IDE Slave            : [Not Detected]
* * Secondary IDE Master         : [Not Detected]
* * Secondary IDE Slave          : [Not Detected]
*
* Hard Disk Write Protect        [Disabled]
* IDE Detect Time Out (Sec)     [35]
* ATA(PI) 80Pin Cable Detection [Host & Device]
*
* * Select Screen
* * Select Item
* +- Change Option
* F1 General Help
* F10 Save and Exit
* ESC Exit
*
*****
v02.67 (C)Copyright 1985-2009, American Megatrends, Inc.

```

➤ **Onboard PCI IDE Controller**

This item specifies the IDE channels used by the onboard PCI IDE controller

Available Options: Primary, Secondary, Both and Disable

Default setting: Both

◆ **Primary/Secondary IDE Master/Slave**

IDE hard drive controllers can support up to two separate hard drives. These drives have a master/slave relationship, which is determined by the cabling configuration used to attach them to the controller.

LBA/Large Mode

LBA (Logical Block Addressing) is a method of addressing data on a disk drive. In LBA mode, the maximum drive capacity is 137 GB. The Optimal and Fail-Safe default setting is *Auto*

Hard Disk Type

The BIOS supports various types for user settings, The BIOS supports <Pri Master>, <Pri Slave>, so the user can install up to two hard disks. For the master and slave jumpers, please refer to the hard disk's installation descriptions and the hard disk jumper settings. You can select <AUTO> under the <TYPE> and <MODE> fields. This will Enabled auto detection of your IDE drives during boot up. This will allow you to change your hard drives (with the power off) and then power on without having to reconfigure your hard drive type. If you use older hard disk drives, which do not

support this feature, then you must configure the hard disk drive in the standard method as described above by the <USER> option.

PIO MODE

PIO means Programmed Input/Output. Rather than have the BIOS issue a series of commands to affect a transfer to or from the disk drive, PIO allows the BIOS to tell the controller what it wants and then let the controller and the CPU perform the complete task by them. This is simpler and more efficient (and faster). Your system supports five modes, numbered from 0 to 4, which primarily differ in timing. When Auto is selected, the BIOS will select the best available mode.

BLOCK (Multi-Sector Transfer)

This option allows your hard disk controller to use the fast block mode to transfer data to and from your hard disk drive (HDD).

S.M.A.R.T

This field is used to activate the S.M.A.R.T (System Management and Reporting Technologies) function for S.M.A.R.T HDD drives. This function requires an application that can give S.M.A.R.T message.

32 Bit Data Transfer

This option sets the 32-bit data transfer option. The Optimal and Fail-Safe default setting is *enabled*.

➤ **Hard Disk Write Protect**

Set this option to protect the hard disk drive from being overwritten. The Optimal and Fail-Safe default setting is *disabled*.

Available Options: Disabled, Enabled

Default setting: Disabled

➤ **IDE Detect Time Out (Sec.)**

Set this option to stop the AMIBIOS from searching for IDE devices within the specified number of seconds. Basically, this allows you to fine-tune the settings to allow for faster boot times. Adjust this setting until a suitable timing that can detect all IDE disk drives attached is found.

Available Options: 0, 5, 10, 15, 20, 25, 30, and 35

Default setting: 35

➤ **ATA(PI) 80 Pin Cable Detection**

Set this option to select the method used to detect the ATA (PI) 80 pin cable. The use of an 80-conductor ATA cable is mandatory for running Ultra ATA/66, Ultra ATA/100 and Ultra ATA/133 IDE hard disk drives. The standard 40-conductor ATA cable cannot handle the higher speeds.

Available options: Host & Device, Host, and Device

Default setting: Host & Device

□ **Remote Access Configuration**

This option turns on remote access support in the BIOS and is the default setting. The remote access feature requires the use of the serial port1 connector at the CN3 or CN4 of the FB2412.

```

Advanced
*****
* Configure Remote Access type and parameters * Select Remote Access
* **** * type.
* Remote Access [Enabled] *
* * *
* Serial port number [COM1] *
* Base Address, IRQ [3F8h, 4] *
* Serial Port Mode [115200 8,n,1] *
* Flow Control [None] *
* Redirection After BIOS POST [Always] *
* Terminal Type [ANSI] *
* VT-UTF8 Combo Key Support [Enabled] *
* Sredir Memory Display Delay [No Delay] *
* * *
* * * Select Screen
* ** * Select Item
* +- * Change Option
* F1 * General Help
* F10 * Save and Exit
* ESC * Exit
* *
*****
v02.67 (C)Copyright 1985-2009, American Megatrends, Inc.

```

➤ **Remote Access**

This field is select remote access type.

Available Options: Enabled and Disable

Default setting: Enabled

➤ **Serial Port number**

This field is the Serial port1 for console redirection. Make sure the port is Enabled.

Available Options: COM1

Default setting: COM1

◆ **Base Address, IRQ**

This field is the I/O port address and Interrupt.

Available Options: 3F8, 4

Default setting: 3F8, 4

➤ **Serial Port Mode**

This field is select Serial port1 can use any mode. Just keep in mind that the bits per second, data bits, parity, and stop bits must match terminal setting.

Available Options: 115200 8,n,1/57600 8,n,1/38400,8,n,1/19200,8,n,1/9600,8,n,1

Default setting: 9600, 8, n, 1

➤ **Flow Control**

This field is Serial port1 can use flow control for console redirection.

Available Options: None, Hardware and Software

Default setting: None

➤ **Redirection After BIOS Post**

These fields is select redirection is active during post and during boot loader or always active or off active. (Some Oss may not work if set to Always)

Available Options: Disabled, Boot Loader and Always

Default setting: Always

➤ **Terminal Type**

This field is selecting the target terminal type.

Available Options: ANSI, VT100 and VT-UTFB

Default setting: ANSI

➤ **VT-UTF8 Combo Key Support**

This field is select VT-UTF8 combination key support for ANSI/VT100 terminals.

Available Options: Enabled and Disabled

Default setting: Enabled

➤ **Sredir Memory Display Delay**

This field is givens the delay in seconds to display memory information.

Available Options: No Delay, Delay 1 Sec, Delay 2 Sec and Delay 4 Sec

Default setting: No Delay

❑ **USB Configuration**

You can use this screen to select options for the USB Configuration.

```

Advanced
*****
* USB Configuration                                     * Enables support for
* ****                                                 * legacy USB. AUTO
* Module Version - 2.24.2-13.4                         * option disables
* ****                                                 * legacy support if
* USB Devices Enabled :                               * no USB devices are
*           None                                       * connected.
* ****                                                 *
* Legacy USB Support                                 [Enabled]
* USB 2.0 Controller Mode                           [HiSpeed]
* BIOS EHCI Hand-Off                               [Enabled]
* ****
* ****
* *          Select Screen
* **        Select Item
* +-        Change Option
* F1        General Help
* F10       Save and Exit
* ESC       Exit
* ****
*****
v02.67 (C)Copyright 1985-2009, American Megatrends, Inc.

```

➤ **Legacy USB Support**

Legacy USB Support refers to the USB mouse and USB keyboard support. Normally if this option is not enabled; any attached USB mouse or USB keyboard will not become available until a USB compatible operating system is fully booted with all USB drivers loaded. When this option is enabled, any attached USB mouse or USB keyboard can control the system even when there is no USB drivers loaded on the system. Set this value to Enabled or Disabled the Legacy USB Support.

Available Options: Disabled, Enabled and AUTO

Default setting: Auto

➤ **USB 2.0 Controller Mode**

This field is configures the USB 2.0 controllers in High speed (480Mbps) or Full speed (12Mbps).

Available Options: HiSpeed and FullSpeed

Default setting: Hispeed

➤ **BIOS ECHI Hand-Off**

This is a workaround for OS without ECHI Hand-Off support. The ECHI ownership change should claim by ECHI driver.

Available Options: Enabled and Disabled

Default setting: Enabled

PCIPnP Setup

Select the *PCI/PnP* tab from the setup screen to enter the Plug and Play BIOS Setup screen. You can display a Plug and Play BIOS Setup option by highlighting it using the <Arrow> keys. All Plug and Play BIOS Setup options are described in this section. The Plug and Play BIOS Setup screen is shown below.

```

Main   Advanced  PCIPnP  Boot   Security  Chipset  Exit
*****
* Advanced PCI/PnP Settings                               ** Clear NVRAM during
* ****                                                    ** System Boot.
* WARNING: Setting wrong values in below sections      **
*               may cause system to malfunction.        **
* ****                                                    **
* Clear NVRAM                                           [No]                **
* Plug & Play O/S                                       [No]                **
* PCI Latency Timer                                    [64]                **
* PCI IDE BusMaster                                    [Disabled]         **
* ****                                                    **
* IRQ3                                                 [Available]        **
* IRQ4                                                 [Available]        **
* IRQ5                                                 [Available]        ** *      Select Screen
* IRQ7                                                 [Available]        ** **     Select Item
* IRQ9                                                 [Available]        ** +-    Change Option
* IRQ10                                                [Available]        ** F1   General Help
* IRQ11                                                [Available]        ** F10  Save and Exit
* IRQ14                                                [Available]        ** ESC  Exit
* IRQ15                                                [Available]        **
* ****                                                    **
*****
v02.67 (C)Copyright 1985-2009, American Megatrends, Inc.
  
```

➤ Clear NVRAM

Clear NVRAM during system boot.

Available Options: Yes, No

Default setting: No

➤ Plug and Plug Aware O/S

Set to Yes to inform BIOS that the operating system can handle Plug and Play (PnP) devices.

Available Options: Yes, No

Default setting: No

➤ PCI Latency Timer

This field specifies the latency timings (in PCI clock) PCI devices installed in the PCI expansion bus.

Available Options: 32, 64, 96, 128, 160, 192, 224, and 248

Default setting: 64

➤ **PCI IDE BusMaster**

This option is to specify that the IDE controller on the PCI local bus have bus-mastering capability.

Available Options: Enabled, Disabled

Default setting: Disabled

➤ **IRQ 3 –15**

When I/O resources are controlled manually, you can assign each system interrupt as one of the following types, based on the type of device using the interrupt:

Available: Specified IRQ is available to the used by PCI/PnP devices.

Reserved: Specified IRQ is reserved for used by Legacy ISA devices.

Available Options: Available and Reserved

Default setting: Available

➤ **DMA Channel 0 – 7**

When I/O resources are controlled manually, you can assign each system DMA as one of the following types, based on the type of device using the interrupt:

ISA/EISA devices comply with the original PC AT bus specification, requiring a specific interrupt (Such as IRQ5 for COM1).

PnP (PCI/ISA) devices: comply with the Plug and Play standard, whether designed for PCI or ISA bus architecture.

➤ **PS/2 Mouse Support**

The PS/2 mouse function is optional. Before you configure this field, make sure your system board supports this feature. The setting of **Enabled** allows the system to detect a PS/2 mouse on boot up. If detected, IRQ12 will be used for the PS/2 mouse. IRQ 12 will be reserved for expansion cards if a PS/2 mouse is not detected. **Disabled** will reserve IRQ12 for expansion cards and therefore the PS/2 mouse will not function.

Available options: Disabled, Enabled and Auto

Default setting: Auto

➤ **Wait for 'F1' If Error**

AMIBIOS POST error messages are followed by:

Press <F1> to continue

If this field is set to **Disabled**, the AMIBIOS does not wait for you to press the <F1> key after an error message.

Available options: Disabled, Enabled

Default setting: Disabled

➤ **Hit 'DEL' Message Display**

Set this field to **Disabled** to prevent the message as follows:

Hit 'DEL' if you want to run setup

It will prevent the message from appearing on the first BIOS screen when the computer boots.

Available options: Disabled, Enabled

Default setting: Enabled

□ **Boot Device**

Use this screen to specify the order in which the system checks for the device to boot from. To access this screen, select Boot Device Priority on the Boot Setup screen and press <Enter>.

➤ **First /Second /Third Hard Disk Boot Device**

Set the boot device options to determine the sequence in which the computer checks which device to boot from. The settings are *Removable Dev.*, *Hard Drive*, or *ATAPI CDROM*.

Note: When you select a boot category from the boot menu, a list of devices in that category appears. For example, if the system has three hard disk drives connected, then the list will show all three hard disk drives attached

□ **Hard Disk Drives**

Use this screen to view the hard disk drives in the system. To access this screen, select Hard disk drives on the Boot Setup screen and press <Enter>.

□ **Removable Drives**

Use this screen to view the removable drives in the system. To access this screen, select removable drives on the Boot Setup screen and press <Enter>.

Security setup

There are two security passwords: Supervisor and User. Supervisor is a privileged person that can change the User password from the BIOS. According to the default setting, both access passwords are not set up and are only valid after you set the password from the BIOS.

- Change Supervisor Password
- Change User Password
- Boot Sector Virus Protection

```

Main   Advanced  PCIPnP  Boot   Security  Chipset  Exit
*****
* Security Settings                                     * Install or Change the
* ****                                                 * password.
* Supervisor Password :Not Installed                   *
* User Password      :Not Installed                   *
*                                                         *
* Change Supervisor Password                           *
* Change User Password                                *
*                                                         *
* Boot Sector Virus Protection [Disabled]              *
*                                                         *
*                                                         *
*                                                         *
* * Select Screen                                     *
* ** Select Item                                     *
* Enter Change                                       *
* F1 General Help                                   *
* F10 Save and Exit                                *
* ESC Exit                                          *
*                                                         *
*****
v02.67 (C)Copyright 1985-2009, American Megatrends, Inc.

```

To set the password, please complete the following steps.

1. Select **Change Supervisor Password**.
 2. Type the desired password (up to 6 character length) when you see the message, "Enter New Supervisor Password."
 3. Then you can go on to set a user password (up to 6 character length) if required. Note that you cannot configure the User password until the Supervisor password is set up.
 4. Enter Advanced BIOS Features screen and point to the Security Option field.
 5. Select System or Setup.
- ✧ **Always:** a visitor who attempts to enter BIOS or operating system will be prompted for password.
 - ✧ **Setup:** a visitor who attempts to the operating system will be prompted for user password. You can enter either User password or Supervisor password.

6. Point to **Save Settings and Exit** and press Enter.
7. Press Y when you see the message, "Save Current Settings and Exit (Y/N)?"

Note: it is suggested that you write down the password in a safe place to avoid that password may be forgotten or missing.

➤ **Clear User Password**

Select Clear User Password from the Security Setup menu and press <Enter>. Clear New Password > [Ok] [Cancel] appears. Type the password and press <Enter>. The screen does not display the characters entered. Retype the password as prompted and press <Enter>.

➤ **Password Check**

This field enables password checking every time the computer is powered on or every time the BIOS Setup is executed. If **Always** is chosen, a user password prompt appears every time and the BIOS Setup Program executes and the computer is turned on. If **Setup** is chosen, the password prompt appears if the BIOS executed.

Available options: Setup, Always

Default setting: Setup

➤ **Boot Sector Virus Protection**

This option is near the bottom of the Security Setup screen. The Optimal and Fail-Safe default setting is *disabled*

Enabled: Set this value to prevent the Boot Sector Virus Protection. This is the default setting.

Disabled: Select Enabled to enable boot sector protection, displays a warning when any program (or virus) issues a Disk Format command or attempts to write to the boot sector of the hard disk drive. If enabled, the following appears when a write is attempted to the boot sector. You may have to type N several times to prevent the boot sector write. Boot Sector Write!

Possible VIRUS: Continue (Y/N)? _

The following appears after any attempt to format any cylinder, head, or sector of any hard disk drive via the BIOS INT 13 Hard disk drive Service:

Format!!!

Possible VIRUS: Continue (Y/N)?

Chipset Setup

This section describes the configuration of the board's chipset features.

- NorthBridge Configuration
- SouthBridge Configuration

```

Main   Advanced  PCIPnP  Boot   Security  Chipset  Exit
*****
* Advanced Chipset Settings                                * Options for NB
* *****
* WARNING: Setting wrong values in below sections        *
*   may cause system to malfunction.                      *
* * NorthBridge Configuration                             *
* * SouthBridge Configuration                             *
* *                                                       *
* *                                                       *
* *                                                       *
* *                                                       *
* *                                                       *
* *                                                       *
* *                                                       *
* * Select Screen                                         *
* ** Select Item                                         *
* Enter Go to Sub Screen                                  *
* F1 General Help                                        *
* F10 Save and Exit                                      *
* ESC Exit                                               *
* *                                                       *
*****
v02.67 (C)Copyright 1985-2009, American Megatrends, Inc.

```

❑ **Northbridge Configuration**

You can use this screen to select options for the North Bridge Configuration. Use the up and down <Arrow> keys to select an item. Use the <Plus> and <Minus> keys to change the value of the selected option.

```

Chipset
*****
* NorthBridge Chipset Configuration * CPU speed divide.
* *****
* CPU Speed Setting [Divide By 1] * The CPU clock
* DRAM Timing Setting By [BIOS] * can't low than
* * Memory speed.
* * Or else, BIOS
* * will set this
* * Question to 0
* * (CPU Divide by 1).
* * Note:This will casue
* * CMOS checksum error.
* *
* * * Select Screen
* * ** Select Item
* * +- Change Option
* * F1 General Help
* * F10 Save and Exit
* * ESC Exit
* *
*****
v02.67 (C)Copyright 1985-2009, American Megatrends, Inc.

```

➤ **CPU Speed Setting**

This Field is CPU speed divide. The CPU clock can't low than Memory speed. Or else, BIOS will set this Question to 0 (CPU Divide by 1). Note: This will cause CMOS checksum error.

Available Options: Divide By 1, and Divide By 2

Default setting: Divide By 1

◆ **DRAM Timing Setting By**

This Field is SDRAM Timing Setting Control. By BIOS: Set timings by hard coding values in BIOS. By Manual: Set timings by Setup Options.

Available Options: BIOS, and Manual

Default setting: BIOS

```

Chipset
*****
* NorthBridge Chipset Configuration                               * SDRAM Timing Setting
* *****                                                       * Control.
*                                                                 *
* CPU Speed Setting [Divide By 1]                               * By BIOS:
* DRAM Timing Setting By [Manual]                               * Set timings by hard
* CAS Latency [ 6 CLKs]                                         * coding values in
* tWR [ 7 CLKs]                                                 * BIOS.
* tRFC [ 38]                                                    *
* tRP [ 7 CLKs]                                                 * By Manual:
* tRCD [15 CLKs]                                                * Set timings by Setup
*                                                                 * Options.
*                                                                 *
* * Select Screen                                             *
* ** Select Item                                             *
* +- Change Option                                           *
* F1 General Help                                           *
* F10 Save and Exit                                         *
* ESC Exit                                                  *
*                                                                 *
*****
v02.67 (C)Copyright 1985-2009, American Megatrends, Inc.
    
```

CAS Latency

This field specifies the DDR Memory Timing: CAS Latency

Available Options: 2, 3, 4, 5, 6, and 7

Default setting: 6

tWR

This field specifies the DDR Memory Timing: write Recovery Time.

Available Options: 0, 1, 2, 3, 4, 5, 6, and 7

Default setting: 7

tRFC

This field specifies the DDR Memory Timing: REF/ACT to REF/ACT delay.

Available Options: 1 ~ 63.

Default setting: 38

tRP

This field specifies the DDR Memory Timing: PRE to ACT command period.

Available Options: 0, 1, 2, 3, 4, 5, 6, and 7

Default setting: 7

tRCD

This field specifies the DDR Memory Timing: ACT to R/W command delay period.

Available Options: 0, 1, 2, 3, 4, 5, 6, 8, 9, 10, 11, 12, 13, 14, and 15

Default setting: 15

❑ **Southbridge Configuration**

You can use this screen to select options for the South Bridge Configuration. South Bridge is a chipset on the motherboard that controls the basic I/O functions, LAN port, and audio function.

```

Chipset
*****
* South Bridge Chipset Configuration * ! Notice ! Native Mode
*                                     * ONLY for Windows(R) XP
*                                     * and 2000.
* OnBoard IDE Operate Mode           [Native Mode]
* USB Port 0,1                       [Enabled]
*
* * ISA Configuration
* * Serial/Parallel Port Configuration
* * WatchDog Configuration
*
* OnBoard LAN Controller             [Enabled]
* Lan Boot ROM Controller            [Disabled]
*
*                                     * *   Select Screen
*                                     * **  Select Item
*                                     * +-   Change Option
*                                     * F1   General Help
*                                     * F10  Save and Exit
*                                     * ESC  Exit
*
*****
v02.67 (C)Copyright 1985-2009. American Megatrends, Inc.
    
```

➤ **OnBoard IDE Operate Mode**

This item specifies the Native Mode ONLY for Windows(R) XP and 2000.

Available Options: Legacy, and Native mode

Default setting: Native mode

➤ **USB Port 0, 1**

Set this value to allow system to enable and disable onboard USB port

Available Options: Disabled, and Enabled

Default setting: Enabled

➤ **On Board LAN Controller**

This field specifies the Enabled or Disabled of the onboard LAN chip.

Available Options: Disabled, and Enabled

Default setting: Enabled

◆ ***LAN Boot ROM Controller***

This field specifies the PXE boot ROM of the onboard LAN chip.

Available Options: Disabled, and Enabled

Default setting: Disabled

Chapter 5 Driver and Utility

The enclosed diskette includes FB2412 VGA and LAN driver. To install and configure you FB2412 system, you need to perform the following steps.

VGA Drivers

➤ **WINDOWS Driver**

- 1 To install the VGA driver, insert the CD ROM into the CD ROM device, and enter DRIVER>VGA>SMI712. If your system is not equipped with a CD ROM device, copy the VGA driver from the CD ROM to a CF.
- 2 Execute setup.exe file.
- 3 The screen shows the SETUP type. Press any key to enter the main menu.
- 4 As the setup is completed, the system will generate the message as follows.

Yes, I want to restart my computer now. Installation is done!

No, I will restart my computer later.

System must be restart then complete the installation.

- 5 In the WINDOWS98/ME, you can find the <DISPLAYL> icon located in the {CONTROL PANEL} group.
- 6 Adjust the <Refresh Rate>, <Cursor Animation>, , <Resolution>, and <Big Cursor>.

Note: If user uses Windows XP operation system, need the update Windows XP service pack2 is provide SMI712 VGA driver.

LAN Utility & Driver

- 1 To install the LAN utility OR driver, insert the CD ROM into the CD ROM device, and enter DRIVER>LAN>RTL8139C>DIAG. If your system is not equipped with a CD ROM device, copy the LAN driver from the CD ROM to a CF.
- 2 Execute install.exe file.

Note: In the LAN directory, a HELPME.EXE file is included to provide installation information.

BIOS Flash Utility

In the <UTILITY> directory, there is the jflash.exe file.

- Step 1: Use the XFLASH.EXE program to update the BIOS setting.
- Step 2: And then refer to the chapter "BIOS Setup", as the steps to modify BIOS.
- Step 3: Now the CPU board's BIOS loaded with are the newest program; user can use it to modify BIOS function in the future, when the BIOS add some functions.

Watchdog Timer

This section describes how to use the Watchdog Timer 0 and Watchdog Timer 1, including disabled, enabled, and triggers functions.

The FB2412 is equipped with a programmable time-out period watchdog timer. User can use the program to enable the watchdog timer. Once you have enabled the watchdog timer, the program should trigger it every time before it times out. If your program fails to trigger or disable this timer before it times out because of system hang-up, it will generate a reset signal to reset the system or trigger an IRQ signal. The time-out period can be programmed to be 30.5µseconds to 512 seconds.

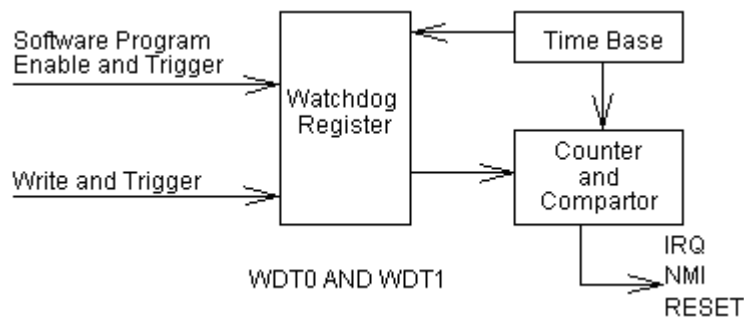

Watchdog Timer Setting

The watchdog timer (WDT0 and WDT1) is a circuit that may be used from your program software to detect crashes or hang-ups. The watchdog timer is automatically disabled after reset.

Once you have enabled the watchdog timer, your program must trigger the watchdog timer every time before it times-out. After you trigger the watchdog timer, it will be set to zero and start to count again. If your program fails to trigger the watchdog timer before time-out, it will generate a reset pulse to reset the system or trigger an IRQ signal and NMI to tell your program that the watchdog is times out. To access WDT0 registers the software programmer use the index port 22hh data port 23h and access WDT1 registers, its use IO ports 68h ~ 6Dh.

➤ **Watchdog timer - WDT0 and WDT1**

WDT 0	3Bh	3Ah	39h
WDT 1	6Ah	6Bh	6Ch
	D7...D0	D7...D0	D7...D0
	Counter [MSB ...LSB]		

For example:

WDT 0	3Bh	3Ah	39h	
WDT 1	6Ah	6Bh	6Ch	
	00h	00h	01h	30.5 μsec
	--	--	02h	61.0μsec
	00h	01h	00h	7.8 m sec
	00h	02h	00h	15.6 m sec
	01h	00h	00h	2 sec
	02h	00h	00h	4 sec
	FFh	FFh	FFh	512 sec

➤ **Select Watchdog Report Signal - WDT0 and WDT1**

WDT 0	38h	
WDT 1	69h	
Bit 7-4	Watchdog timer time out report signal select	
	0000	Reserved
	0001	IRQ3 selected
	0010	IRQ4 selected
	0011	IRQ5 selected
	0100	IRQ6 selected
	0101	IRQ7 selected
	0110	IRQ9 selected
	0111	IRQ10 selected
	1000	IRQ11 selected
	1001	IRQ12 selected
	1010	IRQ14 selected
	1011	IRQ15 selected
	1100	NMI selected
	1101	System reset selected
	1110	Reserved
	1111	Reserved
Bit 3-0	Other function. Please do not modify these bits.	

➤ **Watchdog Enabled/Disabled - WDT0 and WDT1**

WDT 0	37h	
WDT 1	68h	
Bit 7	Reserved.	
Bit 6	0	Disable watchdog timer
	1	Enable watchdog timer
Bit 5-0	Other function. Please do not modify these bits.	

NOTE: 1. If you program the watchdog to generate IRQ15 signal when it times out, you should initial IRQ15 interrupt vector and enable the second interrupt controller (8259 PIC) in order to enable CPU to process this interrupt. An interrupt service routine is required too. Before you configure the IRQ signals, make sure they are not conflicted with other devices, like Floppy, printer, serial ports, LAN, and PS/2 mouse, etc. Refer to Table 2-2 Interrupt Controller for IRQ reference.

2. Before you initialize the interrupt vector of IRQ15 and enable the PIC, please enable the watchdog timer previously; otherwise the watchdog timer will generate an interrupt at the time watchdog timer is enabled. If you want to generate IRQ15 signal to warn your program when watchdog times out, the following table listed the relation of timer factors between time-out periods. And if you use the IRQ15 signal to warn your program when watchdog timer out, please enter the BIOS Setup the <Peripheral Setup> menu, the <OnBoard PCI IDE> and <IDE Prefetch> these two items must set to **Primary**.

➤ **Timeout Status – WDT0 and WDT1**

WDT 0	3Ch	
WDT 1	6Dh	
Bit 7	0	Timer timeout not happened - Read only.
	1	Timer timeout happened - Read only.
Bit 6	Write this bit "1" to reset watchdog timer (Only for WDT 0.)	
Bit 5-0	Other function. Please do not modify these bits.	

➤ **Reload Register - WDT1**

WDT 1	67h	
Bit 7-0	Writer this port to reload Watchdog Timer Counter. The read date is unknown.	

Setup Watchdog Timer Step - WDT0 and WDT1

➤ **WDT0 setup Step:**

1. Unlock Registers by Index 22h and data port 23h.
2. Index 37h Set Bit 6 = 0 to disable the watchdog timer 0 (WDT0).
3. Write the desired counter value to index 3Bh, 3Ah, and 39h.
4. Index 37h Set Bit 6 = 1 to enable the timer, the counter will begin to count up.
5. When counter reaches the setting value, the time out will generate signal setting by index 38h bit [7:4].
6. BIOS can read index 3Ch Bit 7 to decide whether the Watchdog timeout event will happen or not.

To clear the watchdog timer counter:

1. Index 3Ch set Bit 6 = 0 to disable timer. This will also clear counter at the same time.

Watchdog Timer Enabled

To enable the watchdog timer 0 (WDT 0), you have to output a byte of timer factor to the watchdog register whose index address is 22h and data port is 23H. The following is an Assemble program, which demonstrates how to enable the watchdog timer and set the time-out period at 4 seconds.

```
-----  
; Unlock Configuration Register  
-----  
Mov    dx,22h          ; Enter to extended function mode  
Mov    al,13h  
Out    dx,al  
Mov    dx,23h  
Mov    al,c5h  
Out    dx,al  
-----  
; Enabled Watch dog  
-----  
Mov    al,37h  
Mov    dx,22h  
Out    dx,al  
Mov    al,40h          ;Index 37 Bit 6 set 1  
Mov    dx,23h  
Out    dx,al  
-----  
; Lock Configuration Register  
-----  
Mov    dx,22h          ;Exit the extended function mode  
Mov    al,13h  
Out    dx,al  
Mov    dx,23h  
Mov    al,00h  
Out    dx,al
```

Watchdog Timer Trigger

After you enable the watchdog timer, your program must write the same factor as enabling to the watchdog register at least once every time-out period to its previous setting. You can change the time-out period by writing another timer factor to the watchdog register at any time, and you must trigger the watchdog before the new time-out period in next trigger.

```
-----  
; Timer Counter  
-----  
Mov    al,02h  
Mov    dx,3bh          ;Index 3bh set 02h =4 sec  
Out    dx,al  
  
-----  
; System Reset or Interrupt  
-----  
Mov    al,38h  
Mov    dx,22h  
Out    dx,al  
;Mov   al,50h          ;Trigger IRQ7  
Mov    al,d0h          ;System Reset  
Mov    dx,23h  
Out    dx,al  
  
-----  
; Trigger (Reset) Watchdog Timer  
-----  
Mov    al,3ch  
Mov    dx,22h  
In     dx,al  
Or     al,40h          ;Trigger Watchdog  
Mov    dx,23h  
Out    dx,al
```

Watchdog Timer Disabled

To disable the watchdog timer, simply write a 00H to the watchdog register.

```
-----  
; Disabled Watchdog  
-----  
Mov    al,37h  
Mov    dx,22h  
Out    dx,al  
Mov    al,00h          ;Index 37 Bit 6 set 0  
Mov    dx,23h  
Out    dx,al
```

➤ WDT1 setup Step:

1. Write time into register 6Ah-6Ch.
2. Select signal from register 69h.
3. Set register 68h bit 8 to enable WDT1.

To clear the watchdog timer counter:

1. Write any value to register 67H

Watchdog Timer Enabled

To enable the watchdog timer 1 (WDT 1), you have to output a byte of timer factor to the watchdog ports address is 68h. The following is an Assemble program, which demonstrates how to enable the watchdog timer 1 and set the time-out period at 4 seconds.

```
;-----  
; Enabled Watch dog  
;-----  
Mov    al,40h  
Mov    dx,68h      ;IO port 68h Bit 6 set 1  
Out    dx,al
```

Watchdog Timer Trigger

```
;-----  
; Timer Counter  
;-----  
Mov    al,02h  
Mov    dx,6ah      ; IO port 68h set 02h = 4 sec  
Out    dx,al  
  
;-----  
; Interrupt or System Reset  
;-----  
Mov    al,50h      ;Trigger IRQ7  
;Mov   al,d0h      ;System Reset  
Mov    dx,69h      ; IO port 69h Select Int, Reset, NMI signal  
Out    dx,al  
  
;-----  
; Trigger (Reset) Watchdog Timer  
;-----  
Or     al,40h  
Mov    dx,67h      ; IO port 67h Trigger Watchdog  
Out    dx,al
```

Watchdog Timer Disabled

To disable the watchdog timer, simply write a 00H to the watchdog register.

```
;-----  
; Disabled Watchdog  
;-----  
Mov    al,40h      ; IO port 68h disabled Watchdog  
Mov    dx,68h  
Out    dx,al
```

Chapter 6 Technical Reference

This section outlines the errors that may occur when you operate the system, and also gives you the suggestions on solving the problems.

Topic include:

- ❑ Trouble Shooting for Post Beep & Error Messages
- ❑ Technical Reference

Trouble Shooting for Post Beep and Error Messages

The following information informs the Post Beep & error messages. Please adjust your systems according to the messages below. Make sure all the components and connectors are in proper position and firmly attached. If the errors still exist, please contact with your distributor for maintenance.

❑ **POST BEEP**

Currently there are two kinds of beep codes in BIOS setup.

- One indicates that a video error has occurred and the BIOS cannot initialize the video screen to display any additional information. This beep code consists of a single long beep followed by three short beeps.
- The other indicates that an error has occurred in your DRAM. This beep code consists of a constant single long beep.

❑ **Error Message**

➤ **CMOS BATTERY FAILURE**

When the CMOS battery is out of work or has run out, the user has to replace it with a new battery.

➤ **CMOS CHECKSUM ERROR**

This error informs that the CMOS has corrupted. When the battery runs weak, this situation might happen. Please check the battery and change a new one when necessary.

➤ **DISK BOOT FAILURE**

When you can't find the boot device, insert a system disk into Drive A and press < Enter >. Make sure both the controller and cables are all in proper positions, and also make sure the disk is formatted. Then reboot the system.

➤ **DISKETTE DRIVES OR TYPES MISMATCH ERROR**

When the diskette drive type is different from CMOS, please run setup or configure the drive again.

➤ **ERROR ENCOUNTERED INITIALIZING HARD DRIVE**

When you can't initialize the hard drive, ensure the following things:

1. The adapter is installed correctly
2. All cables are correctly and firmly attached
3. The correct hard drive type is selected in BIOS Setup

➤ **ERROR INITIALIZING HARD DISK CONTROLLER**

When this error occurs, ensure the following things:

1. The cord is exactly installed in the bus.
2. The correct hard drive type is selected in BIOS Setup
3. Whether all of the jumpers are set correctly in the hard drive

➤ **KEYBOARD ERROR OR NO KEYBOARD PRESENT**

When this situation happens, please check keyboard attachment and no keys being pressed during the boot. If you are purposely configuring the system without a keyboard, set the error halt condition in BIOS Setup to HALT ON ALL, BUT KEYBOARD. This will cause the BIOS to ignore the missing keyboard and continue the boot procedure.

➤ **MEMORY ADDRESS ERROR**

When the memory address indicates error, you can use this location along with the memory map for your system to find and replace the bad memory chips.

➤ **MEMORY SIZE HAS CHANGED**

Memory has been added or removed since last boot. In EISA mode, use Configuration Utility to re-configure the memory configuration. In ISA mode enter BIOS Setup and enter the new memory size in the memory fields.

➤ **MEMORY VERIFYING ERROR**

It indicates an error verifying a value is already written to memory. Use the location along with your system's memory map to locate the bad chip.

➤ **OFFENDING ADDRESS MISSING**

This message is used in connection with the I/O CHANNEL CHECK and RAM PARITY ERROR messages when the segment that has caused the problem cannot be isolated.

➤ **REBOOT ERROR**

When this error occurs that requires you to reboot. Press any key and the system will reboot.

➤ **SYSTEM HALTED**

Indicates the present boot attempt has been aborted and the system must be rebooted. Press and hold down the CTRL and ALT keys and press DEL.

Technical Reference

□ Physical and Environmental

Temperature: Operating 0°C ~ 60°C

Relative humidity 5 % to 95 % non-condensing

□ Real-Time Clock and Non-Volatile RAM

The FB2412 contains a real-time clock compartment that maintains the date and time in addition to storing configuration information about the computer system. It contains 14 bytes of clock and control registers and 114 bytes of general purpose RAM. Because of the use of CMOS technology, it consumes very little power and can be maintained for long periods of time using an internal Lithium battery. The contents of each byte in the CMOS RAM are listed below:

Address	Description
00	Seconds
01	Second alarm
02	Minutes
03	Minute alarm
04	Hours
05	Hour alarm
06	Day of week
07	Date of month
08	Month
09	Year
0A	Status register A
0B	Status register B
0C	Status register C
0D	Status register D
0E	Diagnostic status byte
0F	Shutdown status byte
10	Diskette drive type byte, drive A and B
11	Fixed disk type byte, drive C

Address	Description
12	Fixed disk type byte, drive D
13	Reserved
14	Equipment byte
15	Low base memory byte
16	High base memory byte
17	Low expansion memory byte
18	High expansion memory byte
19-2D	Reserved
2E-2F	2-byte CMOS checksum
30	Low actual expansion memory byte
31	High actual expansion memory byte
32	Date century byte
33	Information flags (set during power on)
34-7F	Reserved for system BIOS

□ **CMOS RAM Map**

Register	Description
00h -10h	Standard AT-compatible RTC and Status and Status Register data definitions
11h – 13h	Varies
14h	<p>Equipment</p> <p>Bits 7-6 Number of Floppy Drives 00 1 Drive 01 2 Drives</p> <p>Bits 5-4 Monitor Type 00 Not CGA or MDA 01 40x25 CGA 01 2 Drives 80x25 CGA</p> <p>Bits 3 Display Enabled 0 Disabled 1 Enabled</p> <p>Bit 2 Keyboard Enabled 00 Not CGA or MDA 01 40x25 CGA 01 2 Drives 80x25 CGA</p> <p>Bit 1 Math Coprocessor Installed 0 Absent 1 Present</p> <p>Bit 0 Floppy Drive Installed 0 Disabled 1 Enabled</p>
15h	Base Memory (in 1KB increments), Low Byte
16h	Base Memory (in 1KB increments), High Byte
17h	IBM-compatible memory (in 1KB increments), Low Byte
18h	IBM-compatible memory (in 1KB increments), High Byte (max 15 MB)
19h-2Dh	Varies
2Eh	Standard CMOS RAM checksum, high byte
2Fh	Standard CMOS RAM checksum, low byte
30h	IBM-compatible Extended Memory, Low Byte (POST) in KB
31h	IBM-compatible Extended Memory, High Byte (POST) in KB
32h	Century Byte
33h	Reserved. Do not use
34h	Reserved. Do not use
35h	Low byte of extended memory (POST) in 64 KB
36h	High byte of extended memory (POST) in 64 KB
37h-3Dh	Varies
3Eh	Extended CMOS Checksum, Low Byte (including 34h-3Dh)
3Fh	Extended CMOS Checksum, High Byte (including 34h-3Dh)

□ I/O Port Address Map

Each peripheral device in the system is assigned a set of I/O port addresses, which also becomes the identity of the device. There is a total of 1K-port address space available. The following table lists the I/O port addresses used on the Industrial CPU Card.

Address	Device Description
000h - 01Fh	DMA Controller #1
020h - 021h	Interrupt Controller #1
022h - 023h	WDT 0 Control Register
040h - 05Fh	Timer Controller
060h - 064h	Keyboard Controller
066h - 06fh	WTD1 Control Ports
070h - 073h	Real Time Clock, NMI
080h - 09Fh	DMA Page Register
0A0h - 0BFh	Interrupt Controller #2
0C0h - 0DFh	DMA Controller #2
0F0h	Clear Math Coprocessor Busy Signal
0F1h	Reset Math Coprocessor
1F0h - 1F7h	IDE Interface
290h - 297h	System Chipset
2F8h - 2FFh	Serial Port #2(COM2)
2B0 - 2DF	Graphics adapter Controller
3C0 - 3CF	EGA adapter
3D0 - 3DF	CGA adapter
3F8h - 3FFh	Serial Port #1 (COM1)

□ Interrupt Request Lines (IRQ)

There are a total of 15 IRQ lines available on the Industrial CPU Card. Peripheral devices use interrupt request lines to notify CPU for the service required. The following table shows the IRQ used by the devices on the Industrial CPU Card.

Level	Function
IRQ0	System Timer Output
IRQ1	Keyboard
IRQ2	Interrupt Cascade
IRQ3	Serial Port #2
IRQ4	Serial Port #1
IRQ5	LAN #1
IRQ6	- Reserved -
IRQ7	- Reserved -
IRQ8	Real Time Clock
IRQ9	USB#1
IRQ10	- Reserved -
IRQ11	USB#0
IRQ12	PS2 Mouse
IRQ13	FPU
IRQ14	Primary IDE
IRQ15	Secondary IDE(CF)

□ Serial Ports

The ACEs (Asynchronous Communication Elements ACE1 to ACE2) are used to convert parallel data to a serial format on the transmit side and convert serial data to parallel on the receiver side. The serial format, in order of transmission and reception, is a start bit, followed by five to eight data bits, a parity bit (if programmed) and one, one and half (five-bit format only) or two stop bits. The ACEs are capable of handling divisors of 1 to 65535, and produce a 16x clock for driving the internal transmitter logic.

Provisions are also included to use this 16x clock to drive the receiver logic. Also included in the ACE is a completed MODEM control capability, and a processor interrupt system that may be software tailored to the computing time required to handle the communications link.

The following table is a summary of each ACE accessible register

DLAB	Port Address	Register
0	Base + 0	Receiver buffer (read)
		Transmitter holding register (write)
0	Base + 1	Interrupt enable
X	Base + 2	Interrupt identification (read only)
X	Base + 3	Line control
X	Base + 4	MODEM control
X	Base + 5	Line status
X	Base + 6	MODEM status
X	Base + 7	Scratched register
1	Base + 0	Divisor latch (least significant byte)
1	Base + 1	Divisor latch (most significant byte)

➤ Receiver Buffer Register (RBR)

Bit 0-7: Received data byte (Read Only)

➤ Transmitter Holding Register (THR)

Bit 0-7: Transmitter holding data byte (Write Only)

➤ Interrupt Enable Register (IER)

Bit 0: Enable Received Data Available Interrupt (ERBFI)

Bit 1: Enable Transmitter Holding Empty Interrupt (ETBEI)

Bit 2: Enable Receiver Line Status Interrupt (ELSI)

Bit 3: Enable MODEM Status Interrupt (EDSSI)

Bit 4: Must be 0

Bit 5: Must be 0

Bit 6: Must be 0

Bit 7: Must be 0

➤ **Interrupt Identification Register (IIR)**

Bit 0: "0" if Interrupt Pending

Bit 1: Interrupt ID Bit 0

Bit 2: Interrupt ID Bit 1

Bit 3: Must be 0

Bit 4: Must be 0

Bit 5: Must be 0

Bit 6: Must be 0

Bit 7: Must be 0

➤ **Line Control Register (LCR)**

Bit 0: Word Length Select Bit 0 (WLS0)

Bit 1: Word Length Select Bit 1 (WLS1)

WLS1	WLS0	Word Length
0	0	5 Bits
0	1	6 Bits
1	0	7 Bits
1	1	8 Bits

Bit 2: Number of Stop Bit (STB)

Bit 3: Parity Enable (PEN)

Bit 4: Even Parity Select (EPS)

Bit 5: Stick Parity

Bit 6: Set Break

Bit 7: Divisor Latch Access Bit (DLAB)

➤ **MODEM Control Register (MCR)**

Bit 0: Data Terminal Ready (DTR)

Bit 1: Request to Send (RTS)

Bit 2: Out 1 (OUT 1)

Bit 3: Out 2 (OUT 2)

Bit 4: Loop

Bit 5: Must be 0

Bit 6: Must be 0

Bit 7: Must be 0

➤ **Line Status Register (LSR)**

Bit 0: Data Ready (DR)

Bit 1: Overrun Error (OR)

Bit 2: Parity Error (PE)

Bit 3: Framing Error (FE)

Bit 4: Break Interrupt (BI)

Bit 5: Transmitter Holding Register Empty (THRE)

Bit 6: Transmitter Shift Register Empty (TSRE)

Bit 7: Must be 0

➤ **MODEM Status Register (MSR)**

Bit 0: Delta Clear to Send (DCTS)

Bit 1: Delta Data Set Ready (DDSR)

Bit 2: Training Edge Ring Indicator (TERI)

Bit 3: Delta Receive Line Signal Detect (DSLSD)

Bit 4: Clear to Send (CTS)

Bit 5: Data Set Ready (DSR)

Bit 6: Ring Indicator (RI)

Bit 7: Received Line Signal Detect (RSLD)

➤ **Divisor Latch (LS, MS)**

	LS	MS
Bit 0:	Bit 0	Bit 8
Bit 1:	Bit 1	Bit 9
Bit 2:	Bit 2	Bit 10
Bit 3:	Bit 3	Bit 11
Bit 4:	Bit 4	Bit 12
Bit 5:	Bit 5	Bit 13
Bit 6:	Bit 6	Bit 14
Bit 7:	Bit 7	Bit 15

Desired Baud Rate	Divisor Used to Generate 16x Clock
300	384
600	192
1200	96
1800	64
2400	48
3600	32
4800	24
9600	12
14400	8
19200	6
28800	4
38400	3
57600	2
115200	1

Dimension

➤ Top Side

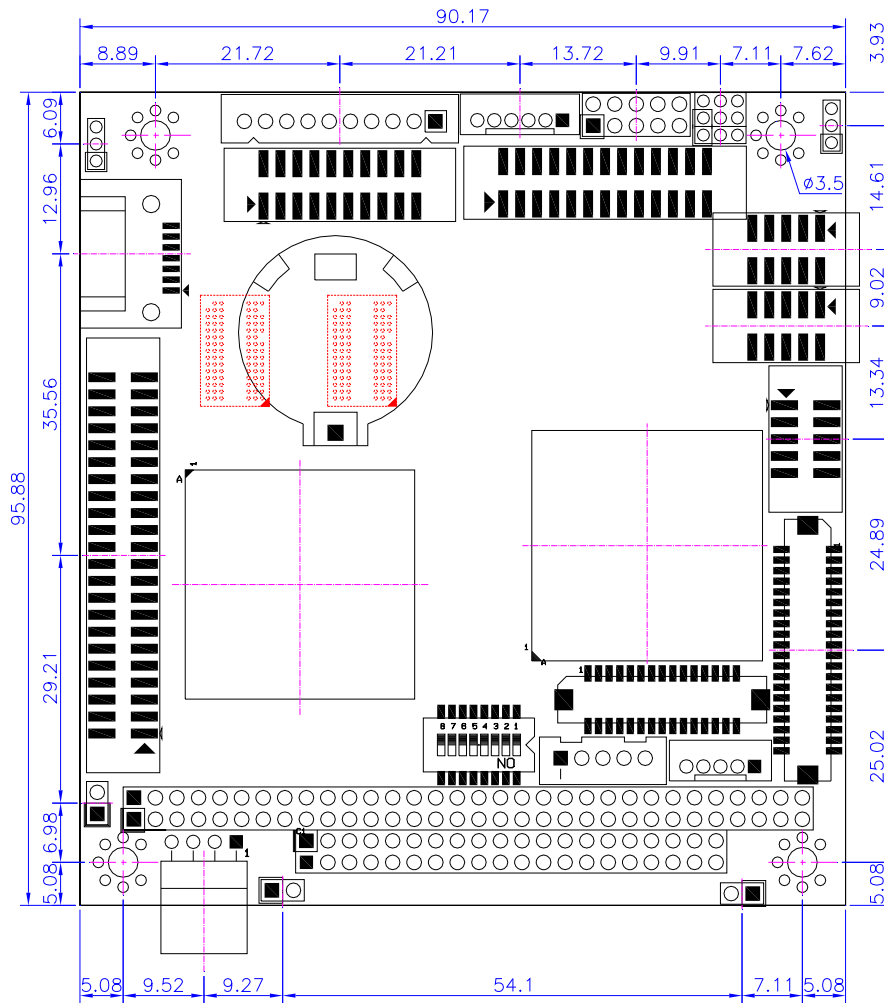

➤ Solder Side

