

User's Manual

Type: EDR-5200



- CONTENTS -

1. IMPORTANT NOTICE	1
2. SPECIAL ABILITY	1
3. REQUIRED ATTENTIONS.....	1
4. SAFETY INFORMATION	
4-1. USING ENVIRONMENT	2
4-2. SYMBOL FOR SAFETY	2
4-3. GENERAL SAFETY INFORMATION	2
5. STRUCTURES AND FUCTIONS OF THIS EQUIPMENT	
5-1. HEAD	4
5-2. A CONSTRUCTION OF A CONTROL KEY-BOARD AND SWITCHES	5
6. CONNECTING AND WORKING THE SYSTEM	
6-1. INSTALLATION	13
6-2. REF/KERATOMETER DATA INPUT	14
7. SETTING UP	
7-1. OPTOMETRY BY A STANDARD PROGRAM	14
7-2. SETTING UP DATE AND TIME	15
7-3. SETTING UP A CONNECTION WITH A CHART PROJECTOR	16
7-4. SETTING UP A CONNECTION WITH A REF/KERATOMETER	16
7-5. SETTING UP SPH	17
7-6. SETTING UP CYL	17
7-7. SETTING UP AXIS	18
7-8. SETTING UP PF	18
7-9. SETTING UP SPEED	19
7-10. SETTING UP COMMUNICATION SPEED	19
7-11. SETTING UP TIME FOR SCREEN SAVER	20
7-12. SETTING UP OTHERS	21
8. BEFORE CALLING TO SERVICE ENGINEER	22
9. COMPOSITIONS	23
10. SPECIFICATION	24

1. IMPORTANT NOTICE

This equipment can be wrong operated by equipments that generate electromagnetic wave (mobile phone, radiotelegraph, remote-controlled things etc). Please pull apart them from this equipment.

When this manual is issued, all information in this manual are confirmed and concluded carefully. But EZER is not responsible for the mistake or oversight of using this manual.

EZER can correct, improve and reform the product or its specification on EZER own sole authority without any notice whenever have to do. And then, this manual may not contain those alterations sometimes.

EZER hold the right of owner-ship of this manual.

According to a copyright law, no one can copy a part or whole of this manual without a prior and written consent from EZER.

2. SPECIAL ABILITY

- (1) This equipment can measure an error of a refraction of an eye.
 - It can control and measure PD.
 - LCD monitor displays current situation.
 - It can alter to several kinds of units
 - You can see and check a VD (Vertex Distance) on VD window.
 - You can input an objective data through an external connective terminal.
- (2) You can measure easily with a control key-board.
- (3) You can connect this equipment with a ref/keratometer and a chart by data cable.
- (4) It has a function for convergence. So you can do a close test (short distance test).

3. REQUIRED ATTENTIONS

- (1) Before using this, check and make a level of the equipment in advance. If it's out of a horizontal, the measurement result could be incorrect.
- (2) Be careful to do not drop or give a shock this equipment. The equipment could be damaged.
- (3) When you use this equipment in a place where is strong light, like sunshine, the measurement result could be incorrect. So please use this in a place where you can control its light, such as a test room or somewhere.
- (4) Do not use any alcohol, thinner, benzene to clean this equipment. The equipment

can be damaged.

- (5) If there's a sudden change of temperature around this equipment, there could be some dewdrops on this equipment. Then please use after disappearing them all.
- (6) If you want to try to use this equipment to connect with other equipments or instruments, please contact to whom you bought this equipment from and ask them in advance.
- (7) Please keep clean the test part. If there are some finger marks, dust or something, they could influence the measurement.
- (8) If there's any smell, smoke or noise, separate the power cable from a wall outlet and call to service engineer or your distributor.
- (9) Please separate the electric wire from a wall outlet and put a dust cover on it during do not use this equipment for a long time.

4. SAFETY INFORMATION

4-1. USING ENVIRONMENT

- (1) This equipment should be used in a place where's clean and no chemical substances or inflammable either.
- (2) Do not use this equipment in a place where's hot and humid too much.
 - Proper temperature for using: 10°C ~ 40°C
 - Proper humidity for using : 30% ~ 75%
- (3) Do never use any volatile liquid to clean the exterior of this equipment.
- (4) Do not disassemble or get shocked this equipment for any purpose.

4-2. SYMBOL FOR SAFETY



SYMBOL	DESCRIPTION
	Attention, consult ACCOMPANYING DOCUMENTS







4-3. GENERAL SATETY INFORMATION

If you find the WARNING or the CAUTION as below, please do as this manual says. You must read and understand this manual enough before using this equipment. While operate this equipment, unless taking care of those sign, troubles and accidents could occur.

This manual should be placed in the user's sight.

CAUTION SIGN	DESCRIPTION

 WARNING	<p>The mark is that a danger could happen, unless be careful. You or the other person could be injured seriously.</p>
 CAUTION	<p>The mark is that a danger could happen, unless be careful. You or the other person could be injured slightly and the equipment could be damaged too.</p>
<p>NOTE</p>	<p>To emphasize the basic information. To avoid using inappropriately, please read this information carefully.</p>

 WARNING	<p>Unless use this equipment in a standard power source, a fire or an electric shock can happen.</p>
 WARNING	<p>Must connect or separate the electric wire after switching off the main power. Never operate this equipment with a wet hand or can be injured by a serious electric shock.</p>
 WARNING	<p>Never disassemble or try to modify this equipment yourself or a fire, an electric shock can happen. There are some dangerous parts inside of this equipment. Touching those parts can make you to be injured or die.</p>
 WARNING	<p>Please switch off the main power and separate the electric wire from AC socket when the symptoms as follows occur.</p> <ul style="list-style-type: none"> • when it is smoky, smelling, noisy, • when slop any liquid or drop any metal into the equipment, • when drop this equipment or case's broken.
 CAUTION	<p>To reduce the electric shock, please connect the cable into the grounded AC socket all the time.</p>
 CAUTION	<p>Because the head of the equipment is heavy, it should be fixed strongly, or a subject person could be damaged.</p>
 CAUTION	<p>When its first operation, it would perform an inspection automatically. Then, please keep a safe distance the subject person from the equipment. Especially, be careful and watch not to get his fingers or something caught in the equipment.</p>

5. STRUCTURES AND FUCTIONS OF THIS EQUIPMENT

5-1. HEAD

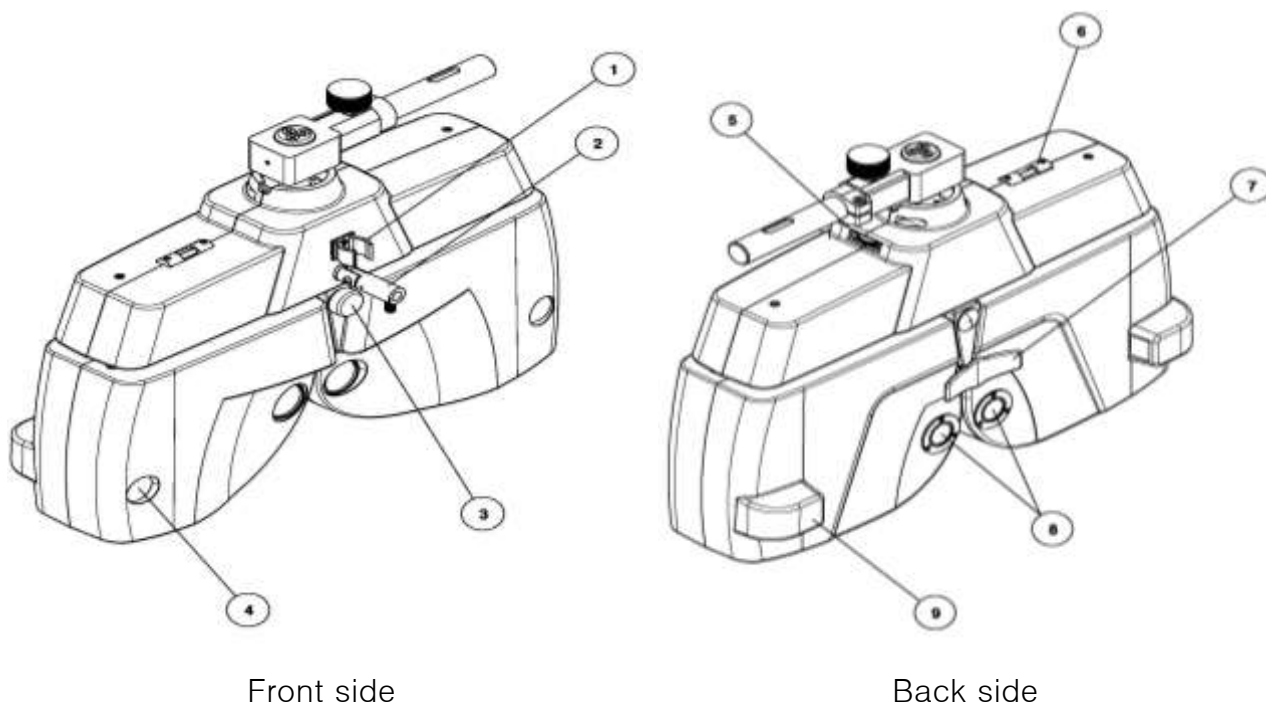

Front side

Back side

- ① Swivel Clip : Used by fix the Swivel Unit.
- ② Swivel Unit : Used by fix the Rod of Short Distance Chart.
- ③ Forehead rest controller : Used by move the Forehead Rest forward.
- ④ VD control window : Used to check the patient's VD.
- ⑤ Level controller grip : Used to control a level.
- ⑥ A level : Used to verify that the refractor head is level.
- ⑦ Forehead rest : Patient's forehead should the rest during measurement.
Clean it before measurement.
- ⑧ Measuring Windows : Patient look at the chart through these windows.
- ⑨ PD control scale

5-2. A CONSTRUCTION OF A CONTROL KEY-BOARD AND SWITCHES

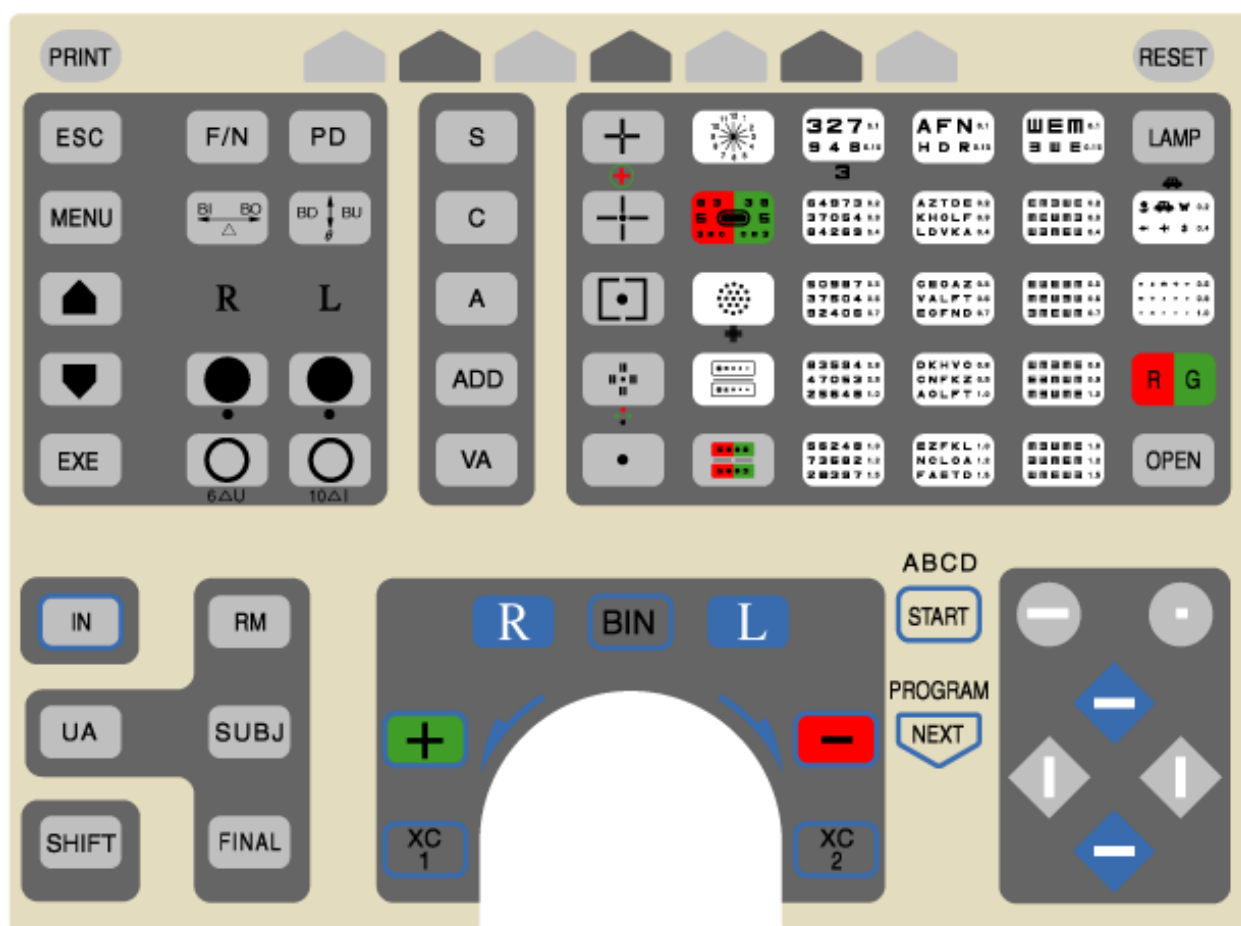
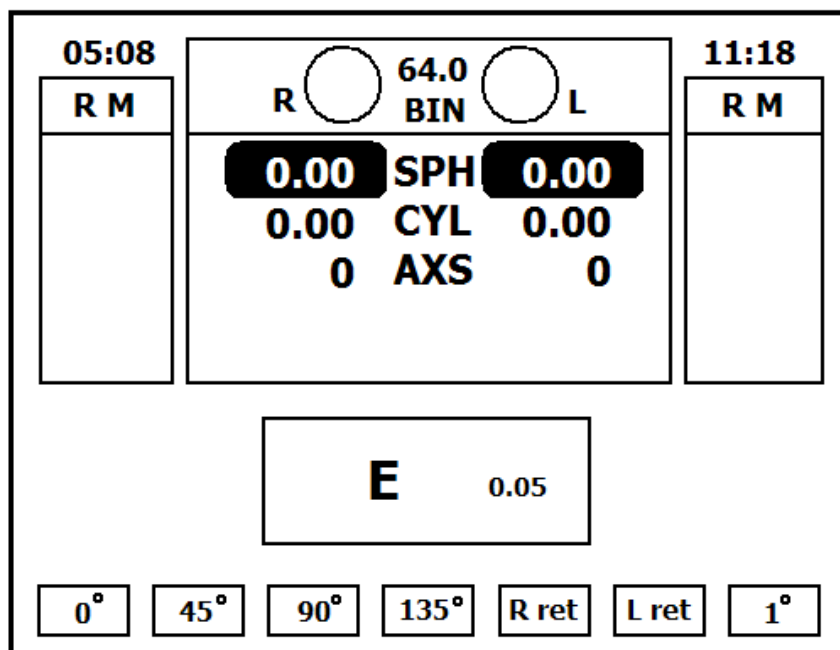

A. DISPLAY
INDICATE SPH, CYL, AXIS.

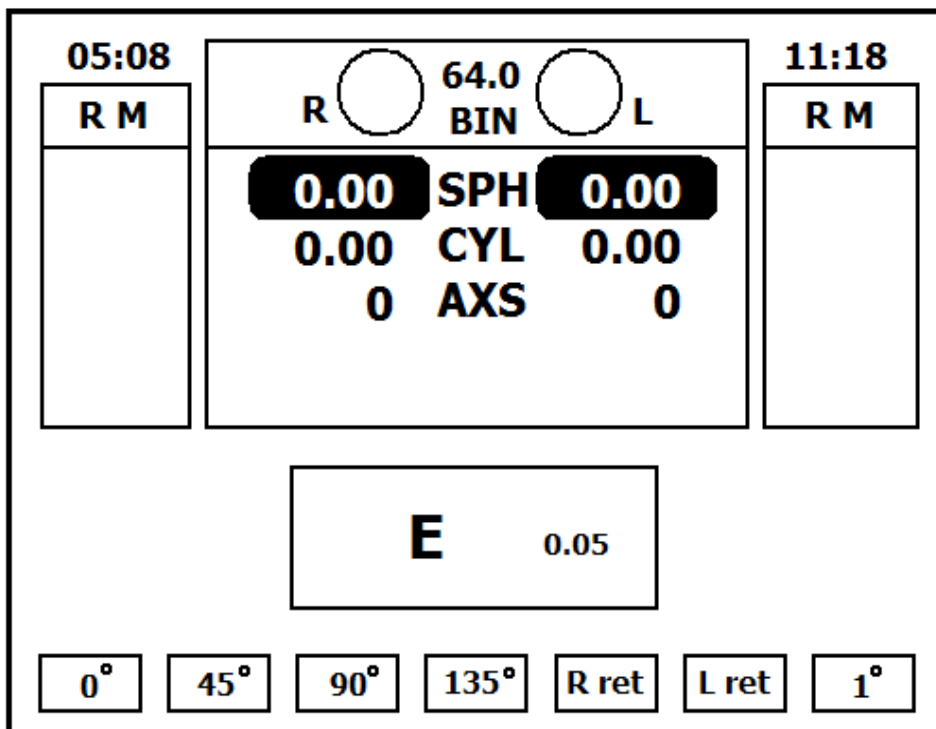

B. CONTRAST ADJUSTMENT KNOB

Located in the lower of the body, used to contrast in the display.

C. CHART KEY

Used to choose a chart.

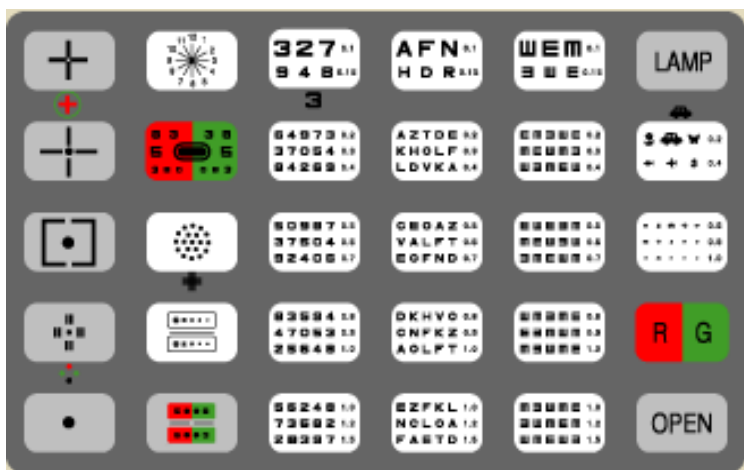



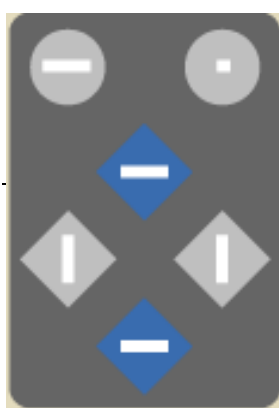

D. MASK KEY



Used when mask the chart. When push the chart key, the mask will disappear. With cross mask, vertical mask, single mask the

measurement will be indicated on the display.

- D-1.  : The switch is to mask the chart from the top to the bottom.
When the mask on the chart already, use it just to push the mask up & down.
- D-2.  : This is used to separate the perpendicular line from the chart.
This is used to move perpendicular mask or a mask of a letter to left or right after arrangement.
- D-3.  : This is used to separate a letter with a chart.
- D-4.  : This is used to separate middle lines of a chart.

E. PROGRAM KEY



Please refer to “7-1. Optometry by normal program.(page 14)” for more detail about program optometry.

- E-1. **START** : The switch for starting programs.
You can go to next step when you press this while a program is operating.

- E-2. **NEXT** : While program optometry is operating, you can change programized data(setting chart or refractor etc) in order.

F. ELECTRONIC DIAL

It is used to change the value of the measurement result.

- Turning right : Changing to - axis
- Turning left : Changing to + axis

G. SWITCH FOR CHANGING CROSS CYLINDER

After changing to cross cylinder lens, go to astigmatic axis measurement mode or astigmatic diopter measurement mode.

When you press  key, it would be R mode automatically and a left eye would be veiled and the mode is changed to astigmatic axis measurement mode.



- G-1. **XC 1** : In astigmatic axis measurement, the - axis of cross cylinder

lens is placed on 45° of the $-$ axis of astigmatic lens.

In astigmatic diopter measurement, the $-$ axis of cross cylinder lens is placed on 90° of the $-$ axis of astigmatic lens.



G-2. XC 2 : In astigmatic axis measurement, the $-$ axis of cross cylinder lens is placed on 135° of the $-$ axis of astigmatic lens.

In astigmatic diopter measurement, the $-$ axis of cross cylinder lens is placed on 0° of the $-$ axis of astigmatic lens.

H. NUMERICAL INPUT SWITCH

It is such as numerical dial.

The basic of shortsightedness and astigmatism is 0.25, and the axis is 5° .



H-1. : Whenever you press this, the numeral goes to "+" by a step.



H-2. : Whenever you press this, the numeral goes to "-" by a step.

- + or : The numeral of shortsightedness go to by 3.00D and astigmatism go to by 2.00D and the axis go to by 10° .

I. MEASUREMENT SELECTION SWITCH

To self-conscious measurement, you can select right(R), left(L) or both eyes(BIN).



A masking curtain would be put in front of the selected eye.

I-1. R : In this, you can input a diopter value only for right eye.

I-2. L : In this, you can input a diopter value only for left eye.

I-3. BIN : Both windows are opened.

You can input a data of diopter for both eyes.

J. DATA KEY



This is used to input a data in to AV-9000.

The data of the selected mode is displayed on the middle of the window.

Which is selected is displayed on the top left of the window.

J-1. **RM** : The measurement data from refractor is displayed on the both windows of RM.

J-2. **UA** : This is used to get unaided VA data. The lens should be 0.00 D.

J-3. **SUBJ** : This is used to get the complete correction data. After being used to communicate with a Ref/Keratometer, it becomes this mode automatically.

J-4. **FINAL** : This is used to get final prescription data or eye sight data.

This switch is for copying the corrected data on prescription part and determining the last data.

K. IN

The lens of the refractor are switched practically as the windows of RM display.

L. SHIFT

When you operate the electronic dial or switch with pressing this, the steps and modes would be changed.



M. CONVERSION SWITCHES



These switches are for parameter-converting, inputting a program.(Refer "setting up on P 14.).

M-1. **ESC** : While you are setting up the menu you can cancel something.

M-2. **MENU** : This is used to set up the menu.

M-3.   : switches for changing parameter or input program.

M-4. **EXE** : This is the switch to decide the setting menu.

N. F/N

You can choose F(far) and N(near) Mode with this.

The selected mode is displayed on top right of central window.

Basically, it is on FAR Mode.

NEAR Mode is used when you do near vision test like relative control horizontal or vertical pupil location test after far vision test and ADD measurement.

ADD is not operated on FAR Mode.

To put $\pm 0.5D$ cross cylinder lens, press 5th FUNCTION KEY.

- O. PD : It controls the pupil distance. (PD MODE).
- P. BI ↔ BO : This mode is to input the absolute value of the polar coordinates or IN/OUT of rectangular coordinates.
- Q. BD ↑ BU : This mode is to input the angle of the polar coordinates or UP/DOWN of rectangular coordinates.
- R. ● : Right or left window is covered.
- **SHIFT** + ● : Right or left Pin hole(Ø1mm) is registered when you press SHIFT and this button at the same time.
- S. ○ : Right or left windows is opened.
- **SHIFT** + ○ (R) : 6△BU are registered on the right window if press SHIFT and ○ button upside of 6△BU button.
 - **SHIFT** + ○ (L) : 10△BI are registered on the left window if press SHIFT and ○ button upside of 10△BI button.

T. MODE KEY

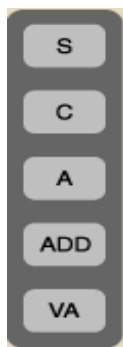

These keys set modes.

When you select a switch, the numerical value which is alterable to will be reversing black and white. It can be altered by **+** **-** keys.

T-1. S : This is the mode to change a spherical degree. (SPH MODE)

T-2. C : This is the mode to change an astigmatic diopter. (CYL MODE)

- **SHIFT** + C : You can change +, - cylinder lenses.

T-3. A : You can change the cylinder axis. (AXIS MODE)

T-4. ADD : You can change the diopter. (ADD MODE)

T-5. VA : You can input a value of measurement data. (VA MODE)

U. FUCTION KEY





Keys for functions on the bottom of display part.



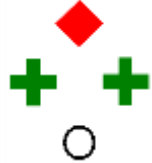

V. PRINT : You can print out a data with this button.

W. RESET : You can delete all data and make it back to the primary stage.

■ KINDS OF SPECIAL MARKS

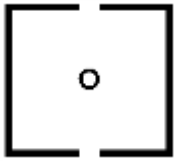
MARK	USE AND NAME	MARK	USE AND NAME
	Dissociated phoria test Polarization chart		Suppression test Red-green chart
	Associated phoria test Polarization chart		Worth 4 dots test 4 dots chart
	Corrected astigmatic axis and diopter accurate test Dot chart		Maddox rod test Dot chart

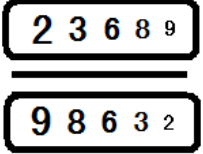
	<p>Stereopsis test Polarization chart</p>		<p>Aniseikonia test Polarization chart</p>
	<p>Eyes balance test Polarization red-green chart</p>		<p>Eye balance test Polarization numeral chart</p>

6. CONNECTING AND WORKING SYSTEM

6-1. INSTALLATION

Connect equipments like this picture as below.

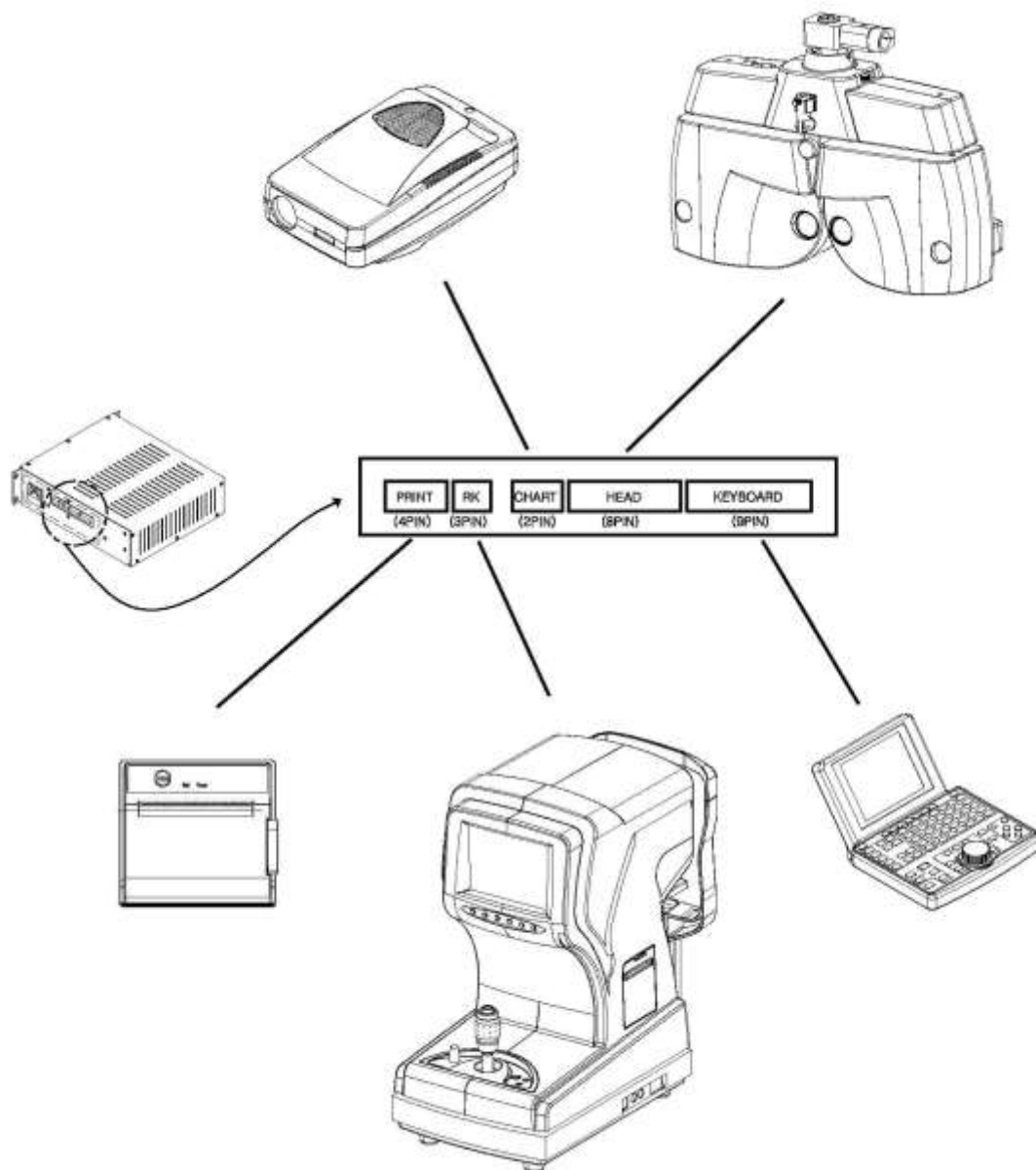

6-2. REF/KERATOMETER DATA INPUT

A. Connect Ref/Keratometer(PRK-9000) to Power box.

Please refer to “6-1. Installation (page 13)”

B. Ref/Keratometer(PRK-9000) measurement mode must “REF” or “R/K”.

You can transmitted with pressing PRINT button in PRK-9000.

C. Press button in AV-9000 Key-Board.

The measurement data from refractor is displayed on the both

windows of RM.

D. Press **RM** button in AV-9000 Key-Board.

The lens of the refractor are switched practically as the windows of RM display.

7. SETTING UP

7-1. OPTOMETRY BY A STANDARD PROGRAM

On this way, you can measure naked eyes or armed eyes easy.

When you press **MENU** button, it would be showed as below.

DATE : 20**--**--**	TIME : ** : ** : **			
CHART : PCN	SPEED : 65			
R M : MRK, PRK	BPS : 9600			
S P H : 3.00	LCD : 10 Min			
C Y L : 2.00	ZERO : v230			
A X S : 10°	DIOPT : ORG			
P F : 135°				
> PROG : A : 00 B : 00 C : 00 D : 00				
<table border="1"> <tbody> <tr> <td>E</td> <td>0.05</td> </tr> </tbody> </table>		E	0.05	
E	0.05			
A	B	C	D	EXIT

then press **◀** key to move. And after pressing **A** and chart key, press **SAVE** button to save it. After all of them, press **EXIT** button to exit.

7-2. SETTING UP DATE AND TIME

Press **MENU** and **SET** , a mode would be changed to Setting Mode.

> DATE : 20**--**--**	TIME : ** : ** : **		
CHART : PCN	SPEED : 65		
R M : MRK, PRK	BPS : 9600		
S P H : 3.00	LCD : 10 Min		
C Y L : 2.00	ZERO : v230		
A X S : 10°	DIOPT : ORG		
P F : 135°			
PROG : A : 00	B : 00 C : 00 D : 00		
<table border="1"><tr><td>E</td><td>0.05</td></tr></table>		E	0.05
E	0.05		
<input type="button" value="SET"/>	<input type="button" value="EXIT"/>		

Press after setting year, month, day, hour, minute and second with and buttons. Or set the number of them with and , then press To save it. As this way, set the time press .

7-3. SETTING UP A CONNECTION WITH A CHART PROJECTOR

DATE : 20**--**--**	TIME : ** : ** : **			
> CHART : PCN	SPEED : 65			
R M : MRK, PRK	BPS : 9600			
S P H : 3.00	LCD : 10 Min			
C Y L : 2.00	ZERO : v230			
A X S : 10°	DIOPT : ORG			
P F : 135°				
PROG : A : 00	B : 00 C : 00 D : 00			
E 0.05				
700D	700A	PCN	PMC	EXIT

Press  and select one of 700D 700A PCN PMC .

7-4. SETTING UP A CONNECTION WITH A REF/KERATOMETER

DATE : 20**--**--**	TIME : ** : ** : **		
CHART : PCN	SPEED : 65		
> R M : MRK, PRK	BPS : 9600		
S P H : 3.00	LCD : 10 Min		
C Y L : 2.00	ZERO : v230		
A X S : 10°	DIOPT : ORG		
P F : 135°			
PROG : A : 00	B : 00 C : 00 D : 00		
E 0.05			
RMA	PRK	RK-	EXIT

Press  and select one of RMA PRK RK- .

7-5. SETTING UP SPH

DATE : 20**--**--**	TIME : ** : ** : **
CHART : PCN	SPEED : 65
R M : MRK, PRK	BPS : 9600
> S P H : 3.00	LCD : 10 Min
C Y L : 2.00	ZERO : v230
A X S : 10°	DIOPT : ORG
P F : 135°	
PROG : A : 00	B : 00 C : 00 D : 00

E	0.05
---	------

1.00	2.00	3.00	EXT
------	------	------	-----

Press  and select one of .

7-6. SETTING UP CYL

DATE : 20**--**--**	TIME : ** : ** : **
CHART : PCN	SPEED : 65
R M : MRK, PRK	BPS : 9600
S P H : 3.00	LCD : 10 Min
> C Y L : 2.00	ZERO : v230
A X S : 10°	DIOPT : ORG
P F : 135°	
PROG : A : 00	B : 00 C : 00 D : 00

E	0.05
---	------

1.00	1.25	2.00	EXT
------	------	------	-----





Press  and select one of .

7-7. SETTING UP AXS

DATE : 20**--**--**	TIME : ** : ** : **
CHART : PCN	SPEED : 65
R M : MRK, PRK	BPS : 9600
S P H : 3.00	LCD : 10 Min
C Y L : 2.00	ZERO : v230
> A X S : 10°	DIOPT : ORG
P F : 135°	
PROG : A : 00	B : 00 C : 00 D : 00

E	0.05
---	------

5°	10°	15°	20°	EXT
----	-----	-----	-----	-----



Press  and select one of    .

7-8. SETTING UP PF

DATE : 20**--**--**	TIME : ** : ** : **
CHART : PCN	SPEED : 65
R M : MRK, PRK	BPS : 9600
S P H : 3.00	LCD : 10 Min
C Y L : 2.00	ZERO : v230
A X S : 10°	DIOPT : ORG
> P F : 135°	
PROG : A : 00	B : 00 C : 00 D : 00

E	0.05
---	------

45°	135°	EXT
-----	------	-----

Press  and select one of  .

7-9. SETTING UP SPEED

DATE : 20**--**--**	TIME : ** : ** : **
CHART : PCN	> SPEED : 65
R M : MRK, PRK	BPS : 9600
S P H : 3.00	LCD : 10 Min
C Y L : 2.00	ZERO : v230
A X S : 10°	DIOPT : ORG
P F : 135°	
PROG : A : 00	B : 00 C : 00 D : 00

E	0.05
---	------

50	55	60	65	70	75	EXIT
----	----	----	----	----	----	------

Press  and select one of .
 And it should be selected more than .

7-10. SETTING UP COMMUNICATION SPEED

DATE : 20**--**--**	TIME : ** : ** : **
CHART : PCN	SPEED : 65
R M : MRK, PRK	> BPS : 9600
S P H : 3.00	LCD : 10 Min
C Y L : 2.00	ZERO : v230
A X S : 10°	DIOPT : ORG
P F : 135°	
PROG : A : 00	B : 00 C : 00 D : 00

E	0.05
---	------



2400	4800	9600	1920	5760	1152	EXIT
------	------	------	------	------	------	------

Press  and select one of .
 7-11. SETTING UP TIME FOR SCREEN SAVER

DATE : 20**-**-**	TIME : ** : ** : **
CHART : PCN	SPEED : 65
R M : MRK, PRK	BPS : 9600
S P H : 3.00	> LCD : 10 Min
C Y L : 2.00	ZERO : v230
A X S : 10°	DIOPT : ORG
P F : 135°	
PROG : A : 00	B : 00 C : 00 D : 00

E	0.05
---	------

5 M	10 M	15 M	EXIT
-----	------	------	------

Press  and select one of   .

7-12. SETTING UP OTHERS

This is the function for after-sales service.

DATE : 20**--**--**	TIME : ** : ** : **
CHART : PCN	SPEED : 65
R M : MRK, PRK	BPS : 9600
S P H : 3.00	LCD : 10 Min
C Y L : 2.00	> ZERO : v230
A X S : 10°	DIOPT : ORG
P F : 135°	
PROG : A : 00	B : 00 C : 00 D : 00

E	0.05
---	------

EXT

DATE : 20**--**--**	TIME : ** : ** : **
CHART : PCN	SPEED : 65
R M : MRK, PRK	BPS : 9600
S P H : 3.00	LCD : 10 Min
C Y L : 2.00	ZERO : v230
A X S : 10°	> DIOPT : ORG
P F : 135°	
PROG : A : 00	B : 00 C : 00 D : 00

E	0.05
---	------

ORG	LM	EXT
-----	----	-----

8. BEFORE CALLING TO SERVICE ENGINEER

When you have any problem, please check the list bellows. If you can not solve that problem with this, call to your local distributor.

When this is not operated even the electric power's "ON".	Check if the electric power cable is connected with an outlet.
	Connect the electric power cable correctly.
There's nothing displayed at all on the controller.	Set the brightness and contrast again.
	Check if the cable is connected with the controller correctly.
Something on the displayed monitor is disappeared unexpectedly.	It is because of "Auto Off". So please just press any key on the controller.
Any keys are not working.	Turn the switch off and on again.
When you can't print out.	Replace print paper by new one or check if papers are jammed inside.

9. COMPOSITIONS

HEAD	1 EA
CONTROL KEY-BOARD	1 EA

JUNCTION BOX	1 EA
PRINTER	1 EA
USER MANUAL	1 EA
NEAR VISION CHART	1 EA
NEAR VISION CHART ROD	1 EA
POWER CABLE	1 EA
DUST COVER	1 EA
DATA CABLE (CHART PROJECTOR, REF/KERATOMETER, PRINTER, HEAD, KEY-BOARD)	1 EA

10. SPECIFICATION

Measurement Range

Spherical Lens	-29.00D ~ +26.75D (0.25D/1.00D/2.00D/3.00D step)
Cylinder Lens	0.00D ~ -9.75D (0.25D/1.00D/2.00D step)
Cylinder Axis	0° ~ 180° (1°/5°/10°/15°/20° step)

PD	50 ~ 80mm (Near Working Distance 35~70cm)
Rotary Prism Lens	0 ~ 20 Δ (0.1 Δ /0.2 Δ /0.5 Δ /1.0 Δ /2.0 Δ step)
Cross Cylinder	\pm 0.25D
Retinoscope	+1.50D (67cm), +2.00D (50cm)
Visual Field	35°

Auxiliary Lens

Occ	
Pinhole Plate	\varnothing 1mm
Maddox Rod	Right Eye (Red, Horizontal) / Left Eye (Green, Vertical)
Red / Green Filter	Right Eye (Red) / Left Eye (Green)
Polarizing Filter	Right Eye (135°,45°) / Left Eye (45°, 135°)
Split Prism	Right Eye (6 Δ BU) / Left Eye (10 Δ BI)
Cross Cylinder Lens	\pm 0.50D (Fixed with the axis set at 90°)

Dimension

Head	450(W) X 308(D) X 131(H), 6.8kg
Controller	230(W) X 268(D) X 152(H), 1.1kg
Thermal Printer	Printing Wide 48mm / Paper Wide 58mm
Power Source	AC 110~120V / AC 220~240V
Power Consumption	120VA

Specifications and designs could be changed by improvement without prior notice.