

SIEMENS

SIMATIC

Standard Software for S7-300 and S7-400 PID Control

User Manual

Preface, Contents

Introduction

Parameter Assignment

Function Blocks

References

Glossary, Index

1

2

3

A

Safety Guidelines

This manual contains notices which you should observe to ensure your own personal safety, as well as to protect the product and connected equipment. These notices are highlighted in the manual by a warning triangle and are marked as follows according to the level of danger:



Danger

indicates that death, severe personal injury or substantial property damage will result if proper precautions are not taken.



Warning

indicates that death, severe personal injury or substantial property damage can result if proper precautions are not taken.



Caution

indicates that minor personal injury or property damage can result if proper precautions are not taken.

Note

draws your attention to particularly important information on the product, handling the product, or to a particular part of the documentation.

Qualified Personnel

The device/system may only be set up and operated in conjunction with this manual.

Only **qualified personnel** should be allowed to install and work on this equipment. Qualified persons are defined as persons who are authorized to commission, to ground, and to tag circuits, equipment, and systems in accordance with established safety practices and standards.

Correct Usage

Note the following:



Warning

This device and its components may only be used for the applications described in the catalog or the technical description, and only in connection with devices or components from other manufacturers which have been approved or recommended by Siemens.

This product can only function correctly and safely if it is transported, stored, set up, and installed correctly, and operated and maintained as recommended.

Trademarks

SIMATIC® and SINEC® are registered trademarks of SIEMENS AG.

Third parties using for their own purposes any other names in this document which refer to trademarks might infringe upon the rights of the trademark owners.

Copyright © Siemens AG 1996 All rights reserved

The reproduction, transmission or use of this document or its contents is not permitted without express written authority. Offenders will be liable for damages. All rights, including rights created by patent grant or registration of a utility model or design, are reserved.

Disclaimer of Liability

We have checked the contents of this manual for agreement with the hardware and software described. Since deviations cannot be precluded entirely, we cannot guarantee full agreement. However, the data in this manual are reviewed regularly and any necessary corrections included in subsequent editions. Suggestions for improvement are welcomed.

Siemens AG
Automation Group
Industrial Automation Systems
Postfach 4848, D-90327 Nürnberg

Technical data subject to change.
© Siemens AG 1996

Siemens Aktiengesellschaft

C79000-G7076-C516

Preface

Purpose

This manual supports you when working with the controller blocks of PID Control.

The manual introduces you to the functions of the controller blocks and familiarizes you with the user interface for assigning parameters to the blocks. This user interface includes online help, that further supports you when assigning parameters to the blocks.

Audience

This manual is intended for the following readers:

- S7 programmers
- Programmers of closed-loop control systems
- Operators
- Service personnel

Structure of “PID Control”

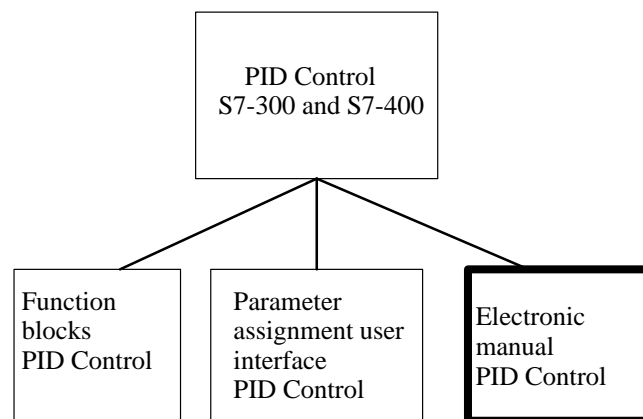

The “PID Control” software package includes the following components:

- The function blocks CONT_C, CONT_S and PULSEGEN.
- The parameter assignment user interface for configuring the controller blocks.
- The manual consisting mainly of a description of the function blocks.

Content of the Manual



Provides you with an overview of PID Control



Explains how to call the parameter assignment user interface



Describes the function blocks FB 41 "CONT_C", FB 42 "CONT_S" and FB 43 "PULSEGEN"

Further Information

This manual is designed as a reference work providing you with the information you require about PID Control. Depending on your experience, you may well need further information that can be found in the manuals /70/, /71/, /100/, /101/, /231/, /232/, /234/.

Additional Assistance

If you have any questions regarding the use or application of PID Control, please contact the Siemens representative in your area.

You will find a list of addresses in the Appendix "SIEMENS Worldwide" in the "S7-400 Programmable Controller, Hardware and Installation" manual.

If you have any questions or comments on this manual, please fill out the remarks form at the end of the manual and return it to the address shown on the form. We would be grateful if you could also take the time to answer the questions giving your personal opinion of the manual.

Siemens also offers a number of training courses to introduce you to the SIMATIC S7 automation system. Please contact your regional training center or the central training center in Nuremberg, Germany for details.

Tel. +49-911-985-3154.

Contents

1	Introduction	1-1
2	Parameter Assignment	2-1
3	Function Blocks	3-1
3.1	Continuous Control with FB41 "CONT_C"	3-2
3.2	Step Control with FB42 "CONT_S"	3-9
3.3	Pulse Generation with FB43 "PULSEGEN"	3-15
3.4	Example of Using PULSEGEN	3-24
A	References	A-1
	Index	Index-1

Introduction

The Concept of PID Control

The function blocks (FBs) of the PID Control package consist of controller blocks for continuous control (CONT_C), for step control (CONT_S), and the FB for pulse duration modulation (PULSEGEN).

The controller blocks implement a purely software controller with the block providing the entire functionality of the controller. The data required for cyclic calculation is stored in data blocks assigned to the FB. This allows the FBs to be called as often as necessary.

FB PULSEGEN is used in conjunction with FB CONT_C to implement a controller with a pulse output for proportional actuators.

Basic Functions

A controller created with the FBs consists of a series of subfunctions that you can activate or deactivate. In addition to the actual controller with its PID algorithm, integrated functions are also available for processing the setpoint and process variable and for adapting the calculated manipulated variable.

Applications

A controller implemented with the two controller blocks is not restricted to any particular application. The performance of the controller and its processing speed is only dependent on the performance of the CPU being used.

With any given CPU, a compromise must be made between the number of controllers and the frequency at which the individual controllers are processed. The speed at which the control loops must be processed, in other words, the more often the manipulated variables must be calculated per unit of time, determines the number of controllers that can be installed (faster loops mean less controllers).

There are no restrictions in terms of the type of process that can be controlled. Both slow processes (temperatures, tank levels etc.) and very fast processes (flow rate, motor speed etc.) can be controlled.

Process Analysis

Note

The static behavior (gain) and the dynamic characteristics (time lag, dead time, reset time etc.) of the process to be controlled have a significant influence on the structuring and design of the controller and on the selection of the dimensions of its static (P component) and its dynamic (I and D components) parameters.

Precise knowledge of the type and characteristic data of the process to be controlled is essential.

Choice of Controller

Note

The characteristics of control loops are decided by the given physical characteristics of the process or machine being controlled and can only be modified in minor ways. Good control quality is only possible if you choose the controller type most suited to your situation and adapt it to the time response of the process.

Creating the Controller

You can create a controller (structuring, parameter assignment, and call in the system program) largely without programming. Knowledge of STEP 7 is, however, necessary.

Online Help

The STEP 7 online help also provides you with information about the various FBs.

Further Information

PID Control is a subset of Standard Control. For further information about the standard controller, refer to **/350/**.

Parameter Assignment

Calling the Parameter Assignment User Interface

You call the parameter assignment user interface of PID Control under Windows 95 using the following menu options:

- **Start ► SIMATIC ► STEP 7 V3 ► PID Control Parameter Assignment**

In the first dialog, you can either open an existing instance data block (DB) for an FB41 “CONT_C” or FB42 “CONT_S” or create a new data block as the instance data block. If you create a new instance data block, you will be prompted to assign the instance DB to an FB.

FB43 “PULSEGEN” does not have a parameter assignment user interface. You must set its parameters with STEP 7 tools.

Note

Using the parameter assignment user interface of PID Control, you can also assign parameters for the integrated control of the CPU 314 IFM. In this case, you create instance DBs that you assign to SFB41 or SFB42.

Online Help

Online help is available in the parameter assignment user interface to support you when you assign parameters to the controller blocks. You can call the online help in three ways:

- Using the menu option **Help ► Contents...**
- By pressing the **F1** key
- By clicking the Help button in the parameter assignment dialogs

Function Blocks

3

Note

The function blocks described in this chapter (FB41 to FB43) have only been released for S7/C7 CPUs with cyclic interrupt levels.

**Chapter
Overview**

Section	Description	Page
3.1	Continuous Control with FB41 "CONT_C"	3-2
3.2	Step Control with FB42 "CONT_S"	3-9
3.3	Pulse Generation with FB43 "PULSEGEN"	3-15
3.4	Example of Using PULSEGEN	3-24

3.1 Continuous Control with FB41 “CONT_C”

Introduction FB “CONT_C” is used on SIMATIC S7 programmable controllers to control technical processes with continuous input and output variables. During parameter assignment, you can activate or deactivate subfunctions of the PID controller to adapt the controller to the process.

Application You can use the controller as a PID fixed setpoint controller or in multi-loop controls as a cascade, blending or ratio controller. The functions of the controller are based on the PID control algorithm of the sampling controller with an analog signal, if necessary extended by including a pulse generator stage to generate pulse duration modulated output signals for two or three step controllers with proportional actuators.

Description Apart from the functions in the setpoint and process value branches, the FB implements a complete PID controller with continuous manipulated variable output and the option of influencing the manipulated value manually. In the following, you will find a detailed description of the subfunctions:

Setpoint Branch

The setpoint is entered in floating-point format at the **SP_INT** input.

Process Variable Branch

The process variable can be input in the peripheral (I/O) or floating-point format. The CRP_IN function converts the PV_PER peripheral value to a floating-point format of -100 to +100 % according to the following formula:

$$\text{Output of CRP_IN} = \text{PV_PER} * \frac{100}{27648}$$

The PV_NORM function normalizes the output of CRP_IN according to the following formula:

$$\text{Output of PV_NORM} = (\text{output of CRP_IN}) * \text{PV_FAC} + \text{PV_OFF}$$

PV_FAC has a default of 1 and PV_OFF a default of 0.

Error Signal

The difference between the setpoint and process variable is the error signal. To suppress a small constant oscillation due to the manipulated variable quantization (for example in pulse duration modulation with PULSEGEN), a dead band is applied to the error signal (DEADBAND). If DEADB_W = 0, the dead band is switched off.

PID Algorithm

The PID algorithm operates as a position algorithm. The proportional, integral (INT), and derivative (DIF) actions are connected in parallel and can be activated or deactivated individually. This allows P, PI, PD, and PID controllers to be configured. Pure I and D controllers are also possible.

Manual Value

It is possible to switch over between a manual and an automatic mode. In the manual mode, the manipulated variable is corrected to a manually selected value. The integrator (INT) is set internally to LMN - LMN_P - DISV and the derivative unit (DIF) to 0 and matched internally. This means that a switchover to the automatic mode does not cause any sudden change in the manipulated value.

Manipulated Value

The manipulated value can be limited to a selected value using the LMNLIMIT function. Signaling bits indicate when a limit is exceeded by the input variable.

The LMN_NORM function normalizes the output of LMNLIMIT according to the following formula:

$$LMN = (\text{output of LMNLIMIT}) * LMN_FAC + LMN_OFF$$

LMN_FAC has the default 1 and LMN_OFF the default 0.

The manipulated value is also available in the peripheral format. The CRP_OUT function converts the floating-point value LMN to a peripheral value according to the following formula:

$$LMN_PER = LMN * \frac{27648}{100}$$

Feedforward Control

A disturbance variable can be fed forward at the **DISV** input.

Modes**Complete Restart/Restart**

FB41 "CONT_C" has a complete restart routine that is run through when the input parameter COM_RST = TRUE is set.

During startup, the integrator is set internally to the initialization value I_ITVAL. When it is called in a cyclic interrupt priority class, it then continues to work starting at this value.

All other outputs are set to their default values.

Error Information

The block does not check for errors internally. The error output parameter RET_VAL is not used.

Block Diagram

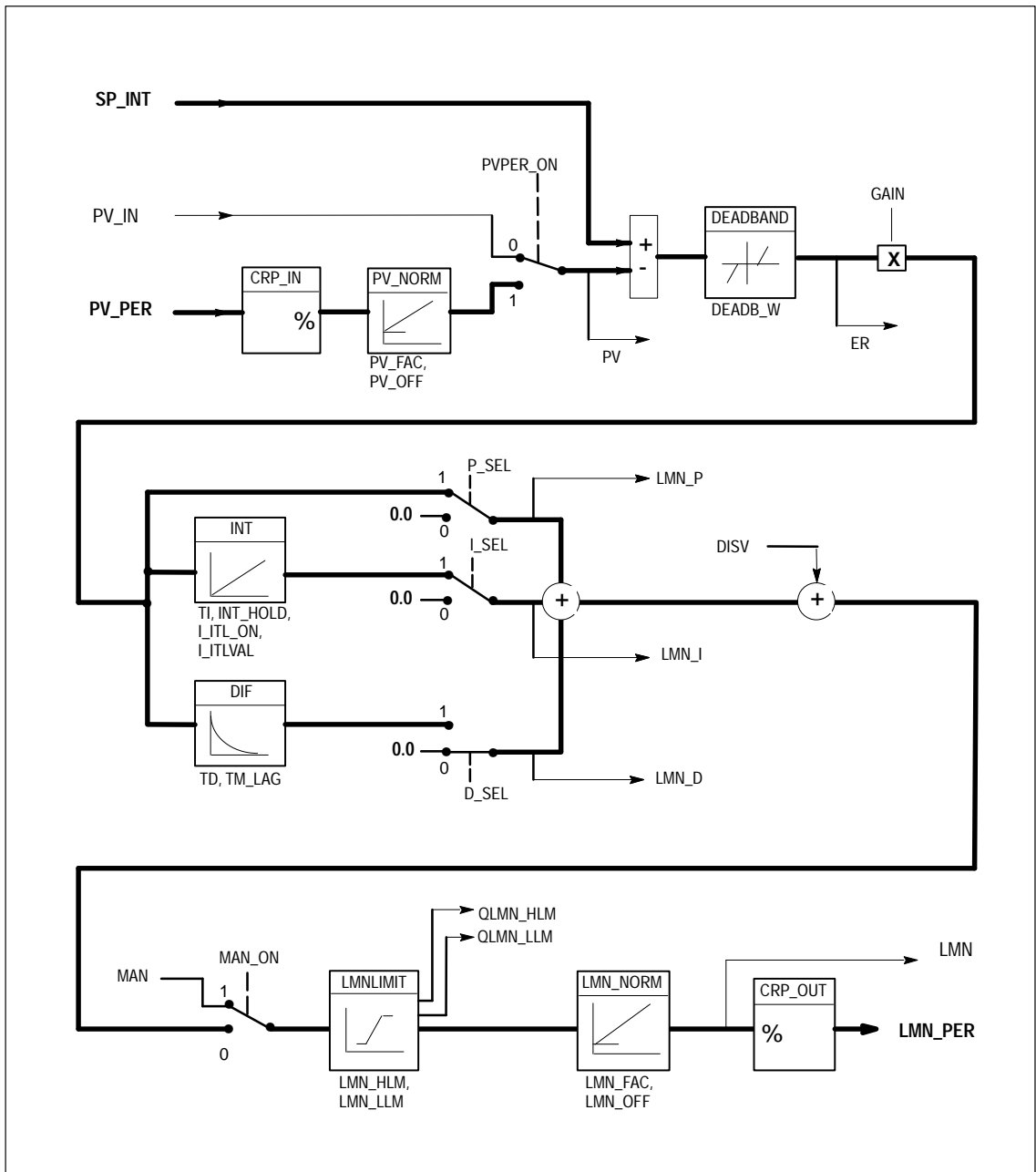

Figure 3-1 Block Diagram of CONT_C

Input Parameters

Table 3-1 contains the description of the input parameters for FB41 “CONT_C”.

Table 3-1 Input Parameters (INPUT) for FB 41 “CONT_C”

Parameter	Data Type	Range of Values	Default	Description
COM_RST	BOOL		FALSE	COMPLETE RESTART The block has a complete restart routine that is processed when the input “complete restart” is set.
MAN_ON	BOOL		TRUE	MANUAL VALUE ON If the input “manual value on” is set, the control loop is interrupted. A manual value is set as the manipulated value.
PVPER_ON	BOOL		FALSE	PROCESS VARIABLE PERIPHERAL ON If the process variable is read from the I/Os, the input PV_PER must be connected to the I/Os and the input “process variable peripheral on” must be set.
P_SEL	BOOL		TRUE	PROPORTIONAL ACTION ON The PID actions can be activated or deactivated individually in the PID algorithm. The P action is on when the input “proportional action on” is set.
I_SEL	BOOL		TRUE	INTEGRAL ACTION ON The PID actions can be activated or deactivated individually in the PID algorithm. The I action is on when the input “integral action on” is set.
INT_HOLD	BOOL		FALSE	INTEGRAL ACTION HOLD The output of the integrator can be “frozen” by setting the input “integral action hold”.
I_ITL_ON	BOOL		FALSE	INITIALIZATION OF THE INTEGRAL ACTION The output of the integrator can be connected to the input I_ITL_VAL by setting the input “initialization of the integral action on”.
D_SEL	BOOL		FALSE	DERIVATIVE ACTION ON The PID actions can be activated or deactivated individually in the PID algorithm. The D action is on when the input “derivative action on” is set.
CYCLE	TIME	>= 1ms	T#1s	SAMPLING TIME The time between the block calls must be constant. The “sampling time” input specifies the time between block calls.
SP_INT	REAL	-100.0...100.0 (%) or phys. value 1)	0.0	INTERNAL SETPOINT The “internal setpoint” input is used to specify a setpoint.
PV_IN	REAL	-100.0...100.0 (%) or phys. value 1)	0.0	PROCESS VARIABLE IN An initialization value can be set at the “process variable in” input or an external process variable in floating point format can be connected.
PV_PER	WORD		W#16#0000	PROCESS VARIABLE PERIPHERAL The process variable in the I/O format is connected to the controller at the “process variable peripheral” input.

Table 3-1 Input Parameters (INPUT) for FB 41 “CONT_C”, continued

Parameter	Data Type	Range of Values	Default	Description
MAN	REAL	-100.0...100.0 (%) or phys. value 2)	0.0	MANUAL VALUE The “manual value” input is used to set a manual value using the operator interface functions.
GAIN	REAL		2.0	PROPORTIONAL GAIN The “proportional value” input specifies the controller gain.
TI	TIME	>= CYCLE	T#20s	RESET TIME The “reset time” input determines the time response of the integrator.
TD	TIME	>= CYCLE	T#10s	DERIVATIVE TIME The “derivative time” input determines the time response of the derivative unit.
TM_LAG	TIME	>= CYCLE/2	T#2s	TIME LAG OF THE DERIVATIVE ACTION The algorithm of the D action includes a time lag that can be assigned at the “time lag of the derivative action” input.
DEADB_W	REAL	>= 0.0 (%) or phys. value 1)	0.0	DEAD BAND WIDTH A dead band is applied to the error. The “dead band width” input determines the size of the dead band.
LMN_HLM	REAL	LMN_LLM ...100.0 (%) or phys. value 2)	100.0	MANIPULATED VALUE HIGH LIMIT The manipulated value is always limited by an upper and lower limit. The “manipulated value high limit” input specifies the upper limit.
LMN_LLM	REAL	-100.0... LMN_HLM (%) or phys. value 2)	0.0	MANIPULATED VALUE LOW LIMIT The manipulated value is always limited by an upper and lower limit. The “manipulated value low limit” input specifies the lower limit.
PV_FAC	REAL		1.0	PROCESS VARIABLE FACTOR The “process variable factor” input is multiplied by the process variable. The input is used to adapt the process variable range.
PV_OFF	REAL		0.0	PROCESS VARIABLE OFFSET The “process variable offset” input is added to the process variable. The input is used to adapt the process variable range.
LMN_FAC	REAL		1.0	MANIPULATED VALUE FACTOR The “manipulated value factor” input is multiplied by the manipulated value. The input is used to adapt the manipulated value range.
LMN_OFF	REAL		0.0	MANIPULATED VALUE OFFSET The “manipulated value offset” is added to the manipulated value. The input is used to adapt the manipulated value range.

Table 3-1 Input Parameters (INPUT) for FB 41 “CONT_C”, continued

Parameter	Data Type	Range of Values	Default	Description
I_ITLVAL	REAL	-100.0...100.0 (%) or phys. value 2)	0.0	INITIALIZATION VALUE OF THE INTEGRAL ACTION The output of the integrator can be set at input I_ITL_ON. The initialization value is applied to the input “initialization value of the integral action”.
DISV	REAL	-100.0...100.0 (%) or phys. value 2)	0.0	DISTURBANCE VARIABLE For feedforward control, the disturbance variable is connected to input “disturbance variable”.

1) Parameters in the setpoint and process variable branches with the same unit

2) Parameters in the manipulated value branch with the same unit

Output Parameters

Table 3-2 contains the description of the output parameters for FB41 “CONT_C”.

Table 3-2 Output Parameters (OUTPUT) for FB 41 “CONT_C”

Parameter	Data Type	Range of Values	Default	Description
LMN	REAL		0.0	MANIPULATED VALUE The effective manipulated value is output in floating point format at the “manipulated value” output.
LMN_PER	WORD		W#16#0000	MANIPULATED VALUE PERIPHERAL The manipulated value in the I/O format is connected to the controller at the “manipulated value peripheral” output.
QLMN_HLM	BOOL		FALSE	HIGH LIMIT OF MANIPULATED VALUE REACHED The manipulated value is always limited to an upper and lower limit. The output “high limit of manipulated value reached” indicates that the upper limit has been exceeded.
QLMN_LLM	BOOL		FALSE	LOW LIMIT OF MANIPULATED VALUE REACHED The manipulated value is always limited to an upper and lower limit. The output “low limit of manipulated value reached” indicates that the lower limit has been exceeded.
LMN_P	REAL		0.0	PROPORTIONAL COMPONENT The “proportional component” output contains the proportional component of the manipulated variable.
LMN_I	REAL		0.0	INTEGRAL COMPONENT The “integral component” output contains the integral component of the manipulated value.
LMN_D	REAL		0.0	DERIVATIVE COMPONENT The “derivative component” output contains the derivative component of the manipulated value.

Table 3-2 Output Parameters (OUTPUT) for FB 41 “CONT_C”, continued

Parameter	Data Type	Range of Values	Default	Description
PV	REAL		0.0	PROCESS VARIABLE The effective process variable is output at the “process variable” output.
ER	REAL		0.0	ERROR SIGNAL The effective error is output at the “error signal” output.

3.2 Step Control with FB42 “CONT_S”

Introduction FB42 “CONT_S” is used on SIMATIC S7 programmable logic controllers to control technical processes with digital manipulated value output signals for integrating actuators. During parameter assignment, you can activate or deactivate subfunctions of the PI step controller to adapt the controller to the process.

Application You can use the controller as a PI fixed setpoint controller or in secondary control loops in cascade, blending or ratio controllers, however not as the primary controller. The functions of the controller are based on the PI control algorithm of the sampling controller supplemented by the functions for generating the binary output signal from the analog actuating signal.

Description Apart from the functions in the process value branch, the FB implements a complete PI controller with a digital manipulated value output and the option of influencing the manipulated value manually. The step controller operates without a position feedback signal.

In the following you will find the description of the partial functions:

Setpoint Branch

The setpoint is entered in floating-point format at the **SP_INT** input.

Process Variable Branch

The process variable can be input in the peripheral (I/O) or floating-point format. The **CRP_IN** function converts the **PV_PER** peripheral value to a floating-point format of -100 to +100 % according to the following formula:

$$\text{Output of CRP_IN} = \text{PV_PER} * \frac{100}{27648}$$

The **PV_NORM** function normalizes the output of **CRP_IN** according to the following formula:

$$\text{Output of PV_NORM} = (\text{output of CRP_IN}) * \text{PV_FAC} + \text{PV_OFF}$$

PV_FAC has a default of 1 and **PV_OFF** a default of 0.

Error Signal

The difference between the setpoint and process variable is the error signal. To suppress a small constant oscillation due to the manipulated variable quantization (for example due to a limited resolution of the manipulated value by the actuator valve), a dead band is applied to the error signal (**DEADBAND**). If **DEADB_W** = 0, the dead band is switched off.

PI Step Algorithm

The FB operates without a position feedback signal. The I action of the PI algorithm and the assumed position feedback signal are calculated in **one** integrator (INT) and compared with the remaining P action as a feedback value. The difference is applied to a three-step element (THREE_ST) and a pulse generator (PULSEOUT) that creates the pulses for the actuator. The switching frequency of the controller can be reduced by adapting the threshold on of the three-step element.

Feedforward Control

A disturbance variable can be fed forward at the **DISV** input.

Modes

Complete Restart/Restart

FB42 "CONT_S" has a complete restart routine that is run through when the input parameter COM_RST = TRUE is set.

All other outputs are set to their default values.

Error Information

The block does not check for errors internally. The error output parameter RET_VAL is not used.

Block Diagram

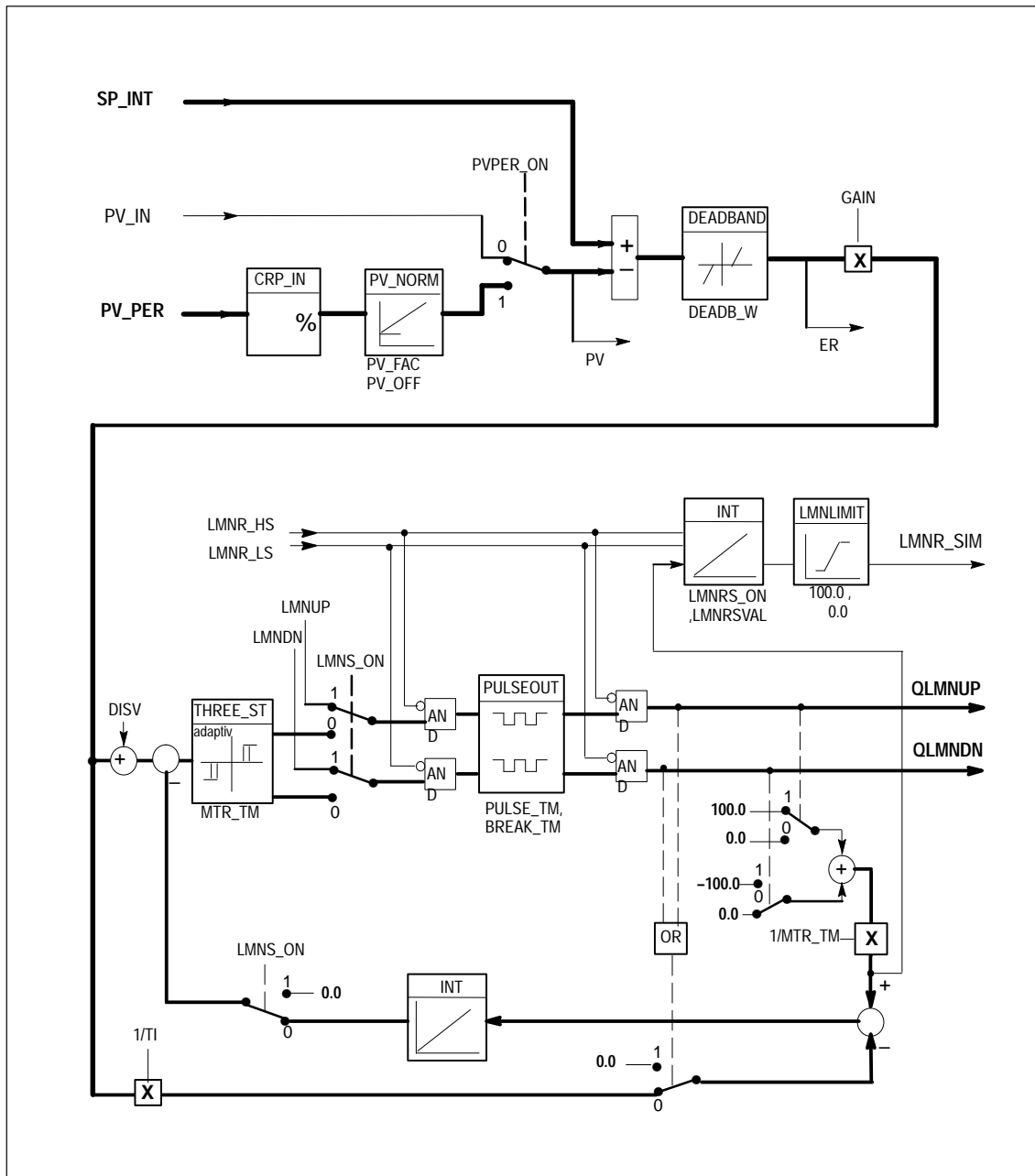

Figure 3-2 Block Diagram of CONT_S

Input Parameters Table 3-3 contains the description of the input parameters for FB42 “CONT_S”.

Table 3-3 Input Parameters (INPUT) for FB 42 “CONT_S”

Parameter	Data Type	Range of Values	Default	Description
COM_RST	BOOL		FALSE	COMPLETE RESTART The block has a complete restart routine that is processed when the input “complete restart” is set.
LMNR_HS	BOOL		FALSE	HIGH LIMIT OF POSITION FEEDBACK SIGNAL The “actuator at upper limit stop” signal is connected to the “high limit of position feedback signal” input. LMNR_HS=TRUE means the actuator is at upper limit stop.
LMNR_LS	BOOL		FALSE	LOW LIMIT OF POSITION FEEDBACK SIGNAL The “actuator at lower limit stop” signal is connected to the “low limit of position feedback signal” input. LMNR_LS=TRUE means the actuator is at lower limit stop.
LMNS_ON	BOOL		FALSE	MANUAL ACTUATING SIGNALS ON The actuating signal processing is switched to manual at the “manual actuating signals on” input..
LMNUP	BOOL		FALSE	ACTUATING SIGNALS UP With manual actuating value signals, the output signal QLMNUP is set at the input “actuating signals up”.
LMNDN	BOOL		FALSE	ACTUATING SIGNALS DOWN With manual actuating value signals, the output signal QLMNDN is set at the input “actuating signals down”.
PVPER_ON	BOOL		FALSE	PROCESS VARIABLE PERIPHERAL ON If the process variable is read in from the I/Os, the input PV_PER must be connected to the I/Os and the input “process variable peripheral on” must be set.
CYCLE	TIME	>= 1ms	T#1s	SAMPLING TIME The time between the block calls must be constant. The “sampling time” input specifies the time between block calls.
SP_INT	REAL	-100.0...100.0 (%) or phys. value 1)	0.0	INTERNAL SETPOINT The “internal setpoint” input is used to specify a setpoint.
PV_IN	REAL	-100.0...100.0 (%) or phys. value 1)	0.0	PROCESS VARIABLE IN An initialization value can be set at the “process variable in” input or an external process variable in floating point format can be connected.
PV_PER	WORD		W#16#0000	PROCESS VARIABLE PERIPHERAL The process variable in the I/O format is connected to the controller at the “process variable peripheral” input.

Table 3-3 Input Parameters (INPUT) for FB 42 "CONT_S", Fortsetzung

Parameter	Data Type	Range of Values	Default	Description
GAIN	REAL		2.0	PROPORTIONAL GAIN The "proportional gain" input sets the controller gain.
TI	TIME	>= CYCLE	T#20s	RESET TIME The "reset time" input determines the time response of the integrator.
DEADB_W	REAL	0.0...100.0 (%) or phys. value 1)	1.0	DEAD BAND WIDTH A dead band is applied to the error. The "dead band width" input determines the size of the dead band.
PV_FAC	REAL		1.0	PROCESS VARIABLE FACTOR The "process variable factor" input is multiplied by the process variable. The input is used to adapt the process variable range.
PV_OFF	REAL		0.0	PROCESS VARIABLE OFFSET The "process variable offset" input is added to the process variable. The input is used to adapt the process variable range.
PULSE_TM	TIME	>= CYCLE	T#3s	MINIMUM PULSE TIME A minimum pulse duration can be assigned with the parameter "minimum pulse time".
BREAK_TM	TIME	>= CYCLE	T#3s	MINIMUM BREAK TIME A minimum break duration can be assigned with the parameter "minimum break time".
MTR_TM	TIME	>= CYCLE	T#30s	MOTOR ACTUATING TIME The time required by the actuator to move from limit stop to limit stop is entered at the "motor actuating time" parameter.
DISV	REAL	-100.0...100.0 (%) or phys. value 2)	0.0	DISTURBANCE VARIABLE For feedforward control, the disturbance variable is connected to input "disturbance variable".

1) Parameters in the setpoint and process variable branches with the same unit

2) Parameters in the manipulated value branch with the same unit

Output Parameters Table 3-4 contains the description of the output parameters for FB42 “CONT_S”.

Table 3-4 Output Parameters (OUTPUT) for FB42 “CONT_S”

Parameter	Data Type	Range of Values	Default	Description
QLMNUP	BOOL		FALSE	ACTUATING SIGNAL UP If the output “actuating signal up” is set, the actuating valve is opened.
QLMNDN	BOOL		FALSE	ACTUATING SIGNAL DOWN If the output “actuating signal down” is set, the actuating valve is opened.
PV	REAL		0.0	PROCESS VARIABLE The effective process variable is output at the “process variable” output.
ER	REAL		0.0	ERROR SIGNAL The effective error is output at the “error signal” output.

3.3 Pulse Generation with FB43 “PULSEGEN”

Introduction FB43 “PULSEGEN” is used to structure a PID controller with pulse output for proportional actuators

Application Using FB43 “PULSEGEN”, PID two or three step controllers with pulse duration modulation can be configured. The function is normally used in conjunction with the continuous controller ~CONT_C”.

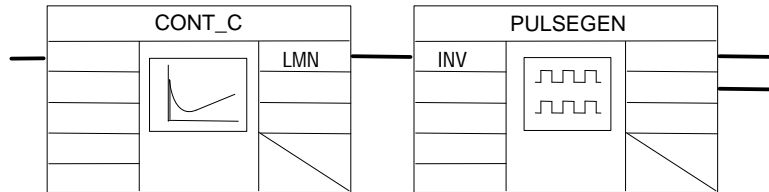

Description The PULSEGEN function transforms the input variable INV (= manipulated value of the PID controller) by modulating the pulse duration into a pulse train with a constant period, corresponding to the cycle time at which the input variable is updated and which must be assigned in PER_TM.

The duration of a pulse per period is proportional to the input variable. The cycle assigned to PER_TM is not identical to the processing cycle of the FB “PULSEGEN”. The PER_TM cycle is made up of several processing cycles of FB “PULSEGEN”, whereby the number of FB “PULSEGEN” calls per PER_TM cycle is the yardstick for the accuracy of the pulse duration modulation.

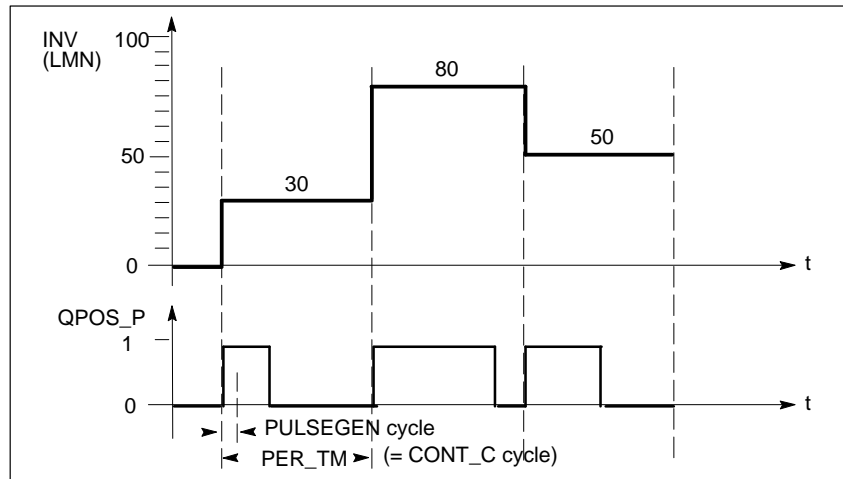

Figure 3-3 Pulse Duration Modulation

An input variable of 30% and 10 FB “PULSEGEN” calls per PER_TM means the following:

- “One” at the QPOS output for the first three calls of FB “PULSEGEN” (30% of 10 calls)
- “Zero” at the QPOS output for seven further calls of FB “PULSEGEN” (70% of 10 calls)

Block Diagram

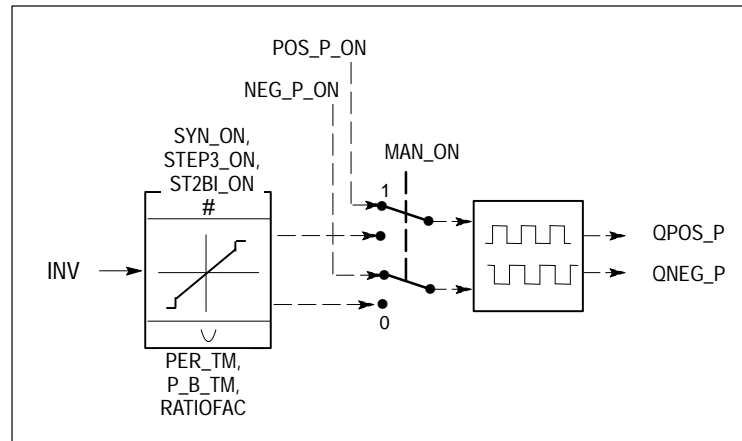

Figure 3-4 Block Diagram of PULSEGEN

Accuracy of the Manipulated Value

With a “sampling ratio” of 1:10 (CONT_C calls to PULSEGEN calls) the accuracy of the manipulated value in this example is restricted to 10%, in other words, set input values INV can only be simulated by a pulse duration at the QPOS output in steps of 10 %.

The accuracy is increased as the number of FB “PULSEGEN” calls per CONT_C call is increased.

If PULSEGEN is called, for example 100 times more often than CONT_C, a resolution of 1 % of the manipulated value range is achieved.

Note

The call frequency must be programmed by the user.

Automatic Synchronization

It is possible to synchronize the pulse output with the block that updates the input variable INV (for example CONT_C). This ensures that a change in the input variable is output as quickly as possible as a pulse.

The pulse generator evaluates the input value INV at intervals corresponding to the period PER_TM and converts the value into a pulse signal of corresponding length.

Since, however, INV is usually calculated in a slower cyclic interrupt class, the pulse generator should start the conversion of the discrete value into a pulse signal as soon as possible after the updating of INV.

To allow this, the block can synchronize the start of the period using the following procedure:

If INV changes and if the block call is not in the first or last two call cycles of a period, the synchronization is performed. The pulse duration is recalculated and in the next cycle is output with a new period (see Figure 3-5).

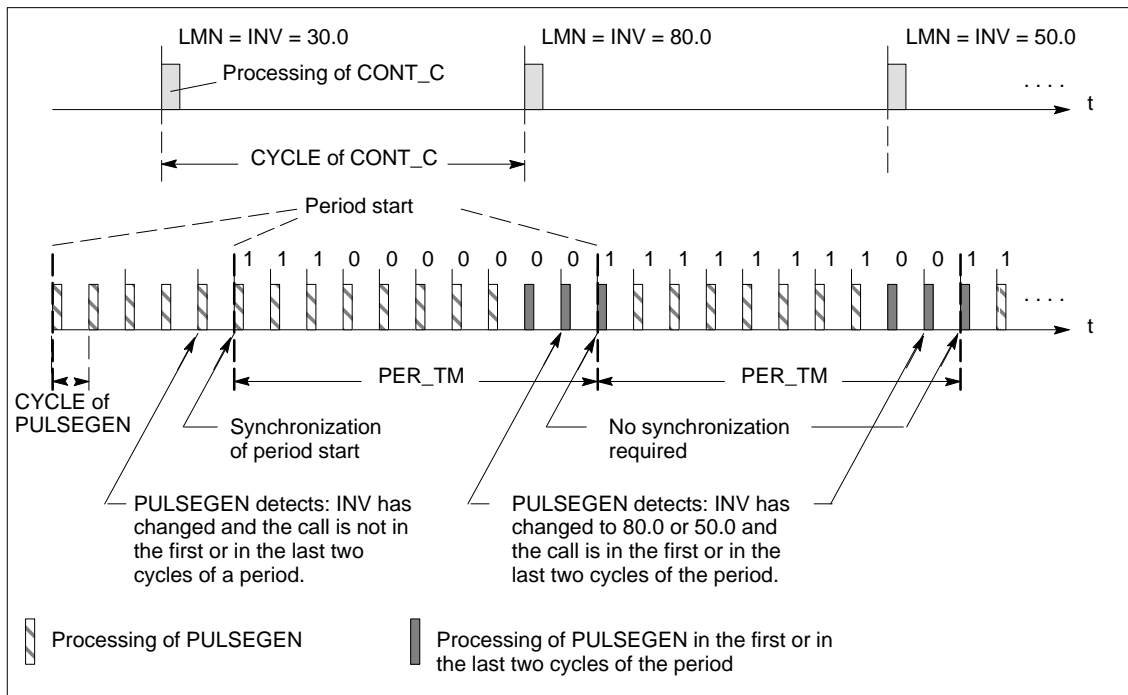

Figure 3-5 Synchronization of the Period Start

The automatic synchronization can be disabled at the “SYN_ON” input (= FALSE).

Note

With the beginning of a new period, the old value of INV (in other words, of LMN) is simulated in the pulse signal more or less accurately following the synchronization.

Modes

Depending on the parameters assigned to the pulse generator, PID controllers with a three-step output or with a bipolar or monopolar two-step output can be configured. The following table illustrates the setting of the switch combinations for the possible modes.

Mode \ Switch	MAN_ON	STEP3_ON	ST2BI_ON
Three-step control	FALSE	TRUE	Any
Two-step control with bipolar control range (-100 % to +100 %)	FALSE	FALSE	TRUE
Two-step control with monopolar control range (0 % ... 100 %)	FALSE	FALSE	FALSE
Manual mode	TRUE	Any	Any

Three-Step Control

In the “three-step control” mode, the actuating signal can adopt three states. The values of the binary output signals QPOS_P and QNEG_P are assigned to the statuses of the actuator.

The table shows the example of a temperature control:

Output signal \ Actuator	Heat	Off	Cool
QPOS_P	TRUE	FALSE	FALSE
QNEG_P	FALSE	FALSE	TRUE

Based on the input variable, a characteristic curve is used to calculate a pulse duration. The form of the characteristic curve is defined by the minimum pulse or minimum break time and the ratio factor (see Figure 3-6). The normal value for the ratio factor is 1. The “doglegs” in the curves are caused by the minimum pulse or minimum break times.

Minimum Pulse or Minimum Break Time

A correctly assigned minimum pulse or minimum break time P_B_TM can prevent short on/off times that reduce the working life of switching elements and actuators.

Note

Small absolute values at the input variable LMN that could otherwise generate a pulse duration shorter than P_B_TM are suppressed. Large input values that would generate a pulse duration longer than (PER_TM - P_B_TM) are set to 100 % or -100 %.

The positive and negative pulse duration is calculated by multiplying the input variable (in %) with the period time:

$$\text{Pulse duration} = \frac{\text{INV}}{100} * \text{PER_TM}$$

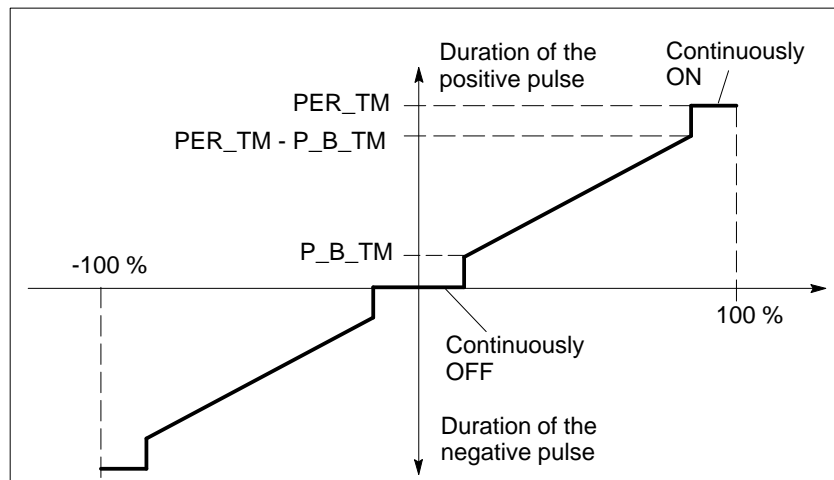

Figure 3-6 Symmetrical Characteristic Curve of the Three-Step Controller (Ratio Factor = 1)

Three-Step Control Asymmetrical

Using the ratio factor **RATIOFAC**, the ratio of the duration of positive to negative pulses can be changed. In a thermal process, for example, this would allow different system time constants for heating and cooling. The ratio factor also influences the minimum pulse or minimum break time. A ratio factor < 1 means that the threshold value for negative pulses is multiplied by the ratio factor.

Ratio Factor < 1

The pulse duration at the negative pulse output calculated from the input variable multiplied by the period time is reduced by the ratio factor (see Figure 3-7).

$$\text{Duration of the positive pulse} = \frac{\text{INV}}{100} * \text{PER_TM}$$

$$\text{Duration of the negative pulse} = \frac{\text{INV}}{100} * \text{PER_TM} * \text{RATIOFAC}$$

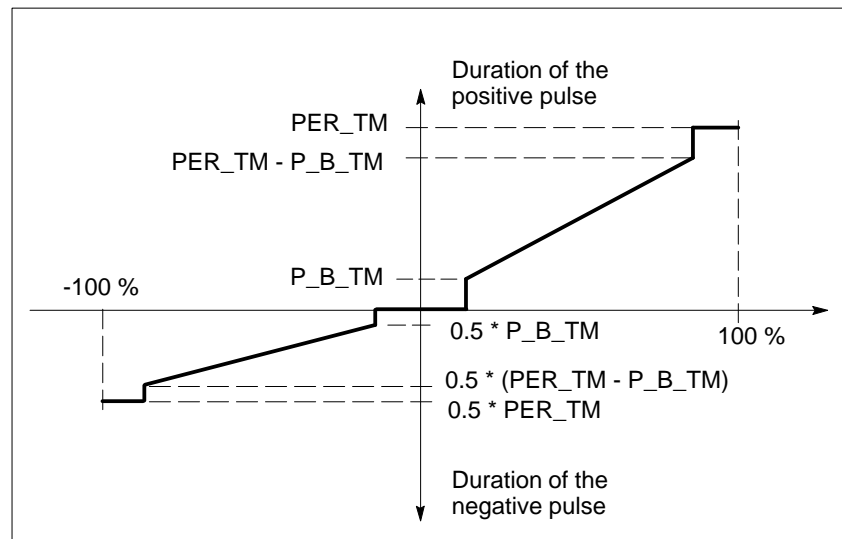

Figure 3-7 Asymmetrical Characteristic Curve of the Three-Step Controller (Ratio Factor = 0.5)

Ratio Factor > 1

The pulse duration at the positive pulse output calculated from the input variable multiplied by the period time is reduced by the ratio factor.

$$\text{Duration of the negative pulse} = \frac{\text{INV}}{100} * \text{PER_TM}$$

$$\text{Duration of the positive pulse} = \frac{\text{INV}}{100} * \frac{\text{PER_TM}}{\text{RATIOFAC}}$$

Two-Step Control

In two-step control, only the positive pulse output QPOS_P of PULSEGEN is connected to the on/off actuator. Depending on the manipulated value range being used, the two-step controller has a bipolar or a monopolar manipulated value range (see Figures 3-8 and 3-9).

Two-Step Control with Bipolar Manipulated Variable Range (-100% to 100%)

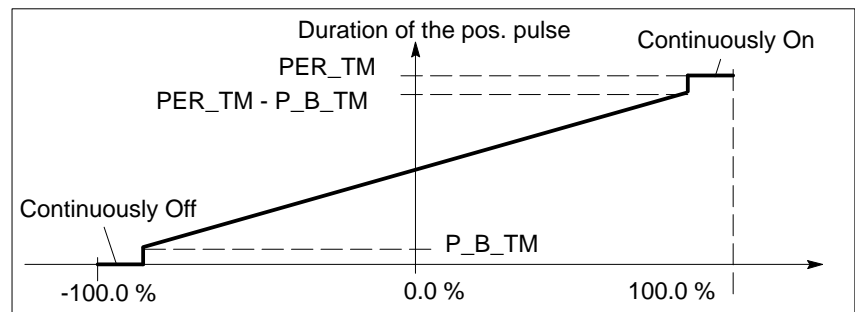

Figure 3-8 Characteristic Curve with Bipolar Manipulated Value Range (-100 % to 100 %)

Two-Step Control with Monopolar Manipulated Variable Range (0% to 100%)

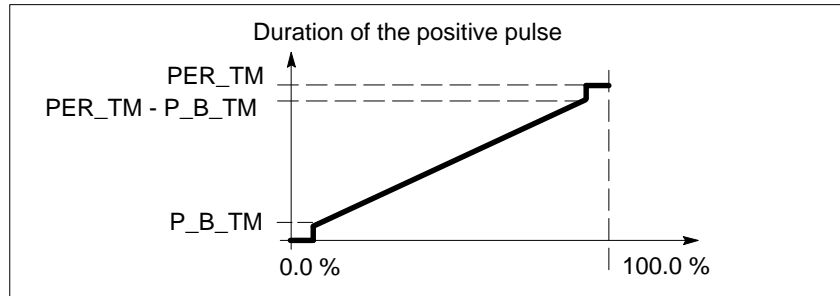

Figure 3-9 Characteristic Curve with Monopolar Manipulated Value Range (0 % to 100 %)

The negated output signal is available at QNEG_P if the connection of the two-step controller in the control loop requires a logically inverted binary signal for the actuating pulses.

Actuator	On	Off
Pulse		
QPOS_P	TRUE	FALSE
QNEG_P	FALSE	TRUE

Manual Mode in Two/Three-Step Control

In the manual mode (MAN_ON = TRUE), the binary outputs of the three-step or two-step controller can be set using the signals POS_P_ON and NEG_P_ON regardless of INV.

	POS_P_ON	NEG_P_ON	QPOS_P	QNEG_P
Three-step control	FALSE	FALSE	FALSE	FALSE
	TRUE	FALSE	TRUE	FALSE
	FALSE	TRUE	FALSE	TRUE
	TRUE	TRUE	FALSE	FALSE
Two-step control	FALSE	Any	FALSE	TRUE
	TRUE	Any	TRUE	FALSE

Modes

Complete Restart/Restart

During a complete restart, all the signal outputs are set to 0.

Error Information

The block does not check for errors internally. The error output parameter RET_VAL is not used.

Input parameters

Table 3-5 Input Parameters (INPUT) for FB 43 "PULSEGEN"

Parameter	Data Type	Range of Values	Default	Description
INV	REAL	-100.0...100.0 (%)	0.0	INPUT VARIABLE An analog manipulated value is connected to the input parameter "input variable".
PER_TM	TIME	>=20*CYCLE	T#1s	PERIOD TIME The constant period of pulse duration modulation is input with the "period time" input parameter. This corresponds to the sampling time of the controller. The ratio between the sampling time of the pulse generator and the sampling time of the controller determines the accuracy of the pulse duration modulation.
P_B_TM	TIME	>= CYCLE	T#50ms	MINIMUM PULSE/BREAK TIME A minimum pulse or minimum break time can be assigned at the input parameters "minimum pulse or minimum break time".
RATIOFAC	REAL	0.1 ...10.0	1.0	RATIO FACTOR The input parameter "ratio factor" can be used to change the ratio of the duration of negative to positive pulses. In a thermal process, this would, for example, allow different time constants for heating and cooling to be compensated (for example, in a process with electrical heating and water cooling).
STEP3_ON	BOOL		TRUE	THREE STEP CONTROL ON The "three-step control on" input parameter activates this mode. In three-step control, both output signals are active.
ST2BI_ON	BOOL		FALSE	TWO STEP CONTROL FOR BIPOLAR MANIPULATED VALUE RANGE ON With the input parameter "two-step control for bipolar manipulated value range on" you can select between the modes "two-step control for bipolar manipulated value" and "two-step control for monopolar manipulated value range". The parameter STEP3_ON = FALSE must be set.
MAN_ON	BOOL		FALSE	MANUAL MODE ON By setting the input parameter "manual mode on", the output signals can be set manually.
POS_P_ON	BOOL		FALSE	POSITIVE PULSE ON In the manual mode with three-step control, the output signal QPOS_P can be set at the input parameter "positive pulse on". In the manual mode with two-step control, QNEG_P is always set inversely to QPOS_P.
NEG_P_ON	BOOL		FALSE	NEGATIVE PULSE ON In the manual mode with three-step control, the output signal QNEG_P can be set at the input parameter "negative pulse on". In the manual mode with two-step control, QNEG_P is always set inversely to QPOS_P.

Table 3-5 Input Parameters (INPUT) for FB 43 “PULSEGEN”, continued

Parameter	Data Type	Range of Values	Default	Description
SYN_ON	BOOL		TRUE	SYNCHRONIZATION ON By setting the input parameter “synchronization on”, it is possible to synchronize automatically with the block that updates the input variable INV. This ensures that a changing input variable is output as quickly as possible as a pulse.
COM_RST	BOOL		FALSE	COMPLETE RESTART The block has a complete restart routine that is processed when the “complete restart” input is set.
CYCLE	TIME	>= 1ms	T#10ms	SAMPLING TIME The time between block calls must be constant. The “sampling time” input specifies the time between block calls.

Note

The values of the input parameters are not limited in the block. There is no parameter check.

Output Parameters

Table 3-6 Output Parameters (OUTPUT) for FB43 “PULSEGEN”

Parameter	Data Type	Range of Values	Default	Description
QPOS_P	BOOL		FALSE	OUTPUT POSITIVE PULSE The output parameter “output positive pulse” is set when a pulse is to be output. In three-step control, this is always the positive pulse. In two-step control, QNEG_P is always set inversely to QPOS_P.
QNEG_P	BOOL		FALSE	OUTPUT NEGATIVE PULSE The output parameter “output negative pulse” is set when a pulse is to be output. In three-step control, this is always the negative pulse. In two-step control, QNEG_P is always set inversely to QPOS_P.

3.4 Example of Using PULSEGEN

Control Loop Using the continuous controller CONT_C and the pulse generator PULSEGEN, you can implement a fixed setpoint controller with a switching output for proportional actuators. Figure 3-10 illustrates the basic signal sequence in the control loop.

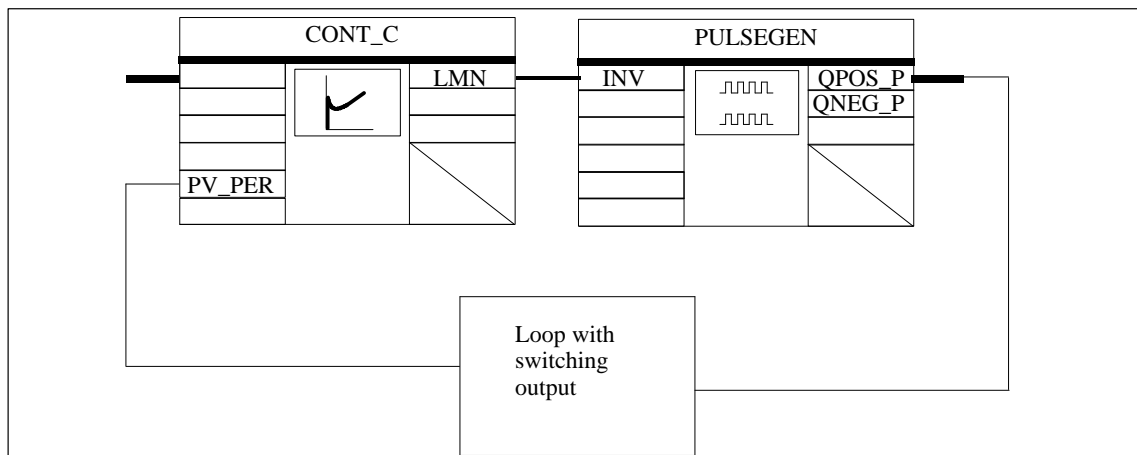

Figure 3-10 Control Loop

The continuous controller CONT_C forms the manipulated value LMN, that is converted to pulse-break signals QPOS_P or QNEG_P by the pulse generator PULSEGEN.

Block call and Connection

The fixed setpoint controller with a switching output for proportional actuators PULS_CTR consists of the blocks CONT_C and PULSEGEN. The block call is implemented so that CONT_C is called every 2 seconds ($=\text{CYCLE} * \text{RED_FAC}$) and PULSEGEN every 10 ms ($=\text{CYCLE}$). The cycle time of OB35 is set to 10 ms. The connections can be seen in Figure 3-11.

During a complete restart, the block PULS_CTR is called in OB100 and input COM_RST is set to TRUE.

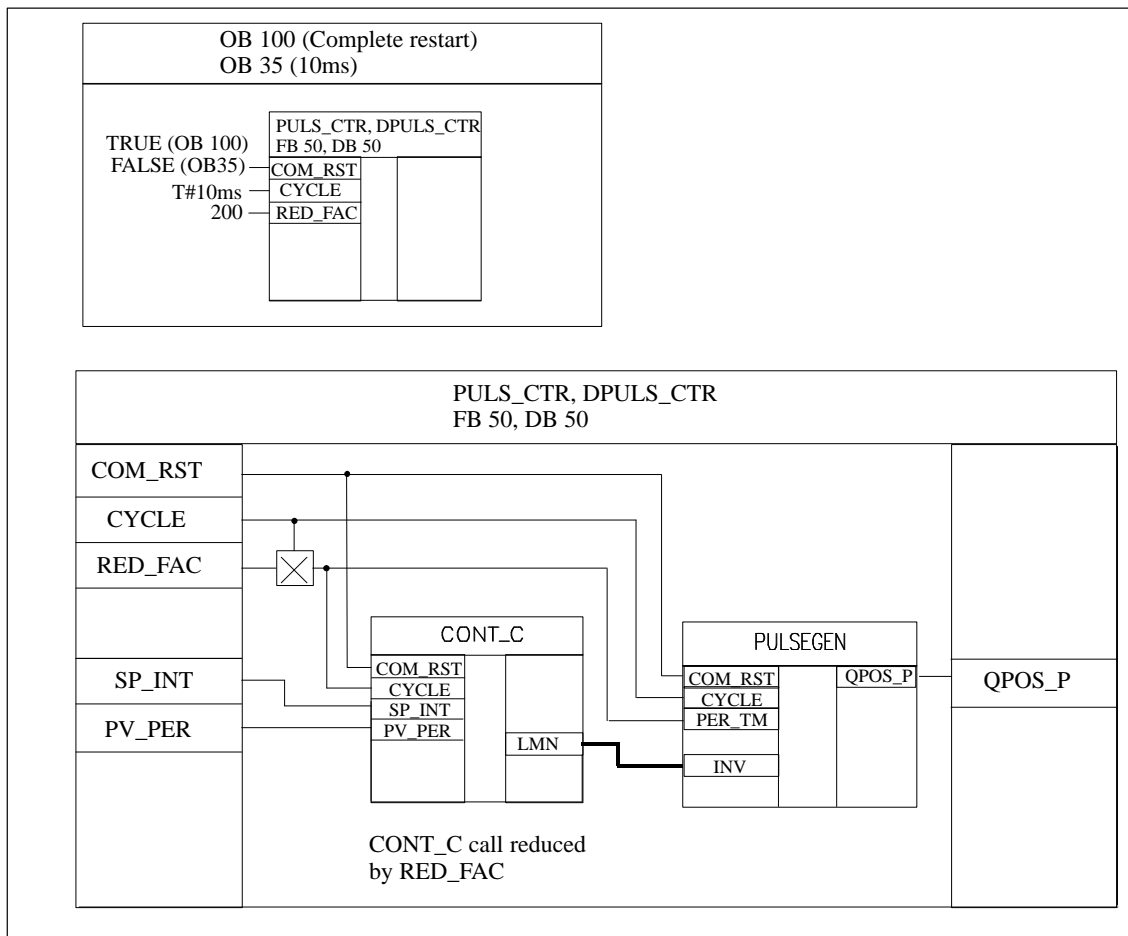

Figure 3-11 Block Call and Interconnection

STL Program for FB PULS_CTRL

Table 3-7 FB PULS_CTRL

Address	Declaration	Name	Type	Comment
0.0	in	SP_INT	REAL	Setpoint
4.0	in	PV_PER	WORD	Process variable in periph. format
6.0	in	RED_FAC	INT	Call reducing factor
8.0	in	COM_RST	BOOL	Complete restart
10.0	in	CYCLE	TIME	Sampling time
14.0	out	QPOS_P	BOOL	Actuating signal
16.0	stat	DI_CONT_C	FB-CONT_C	Counter
142.0	stat	DI_PULSEGEN	FB-PULSEGEN	Counter
176.0	stat	sCount	INT	Counter
0.0	temp	tCycCtr	TIME	Controller sampling time

Table 3-8 Network 1

STL	Description
A #COM_RST	//Complete restart routine
JCN M001	
L 0	
T #sCount	
M001: L #CYCLE	//Calculate controller sampling time
L #RED_FAC	
*D	
T #tCycCtr	
L #sCount	//Decrement counter and compare with zero
L 1	
-I	
T #sCount	
L 0	
<=I	
JCN M002	//Conditional block call and set counter
CALL #DI_CONT_C	
COM_RST :=#COM_RST	
CYCLE :=#tCycCtr	
SP_INT :=#SP_INT	
PV_PER :=#PV_PER	
L #RED_FAC	
T #sCount	
M002: L #DI_CONT_C.LMN	
T #DI_PULSEGEN.INV	
CALL #DI_PULSEGEN	
PER_TM :=#tCycCtr	
COM_RST :=#COM_RST	
CYCLE :=#CYCLE	
QPOS_P :=#QPOS_P	
BE	

References

A

- /70/* Manual: *S7-300 Programmable Controller, Hardware and Installation*
- /71/* Reference Manual: *S7-300, M7-300 Programmable Controllers Module Specifications*
- /100/* Manual: *S7-400/M7-400 Programmable Controllers, Hardware and Installation*
- /101/* Reference Manual: *S7-400/M7-400 Programmable Controllers Module Specifications*
- /231/* User Manual: *Standard Software for S7 and M7, STEP 7*
- /232/* Manual: *Statement List (STL) for S7-300 and S7-400, Programming*
- /234/* Programming Manual: *System Software for S7-300 and S7-400 Program Design*
- /350/* User Manual: *SIMATIC S7, Standard Control*

Index

A

Applications, 1-1

C

CONT_C, 3-2

CONT_S, 3-9

Continuous control, 1-1

Control

 continuous control with SFB41, 3-2

 step control with FB42, 3-9

Controller, choosing, 1-2

CPU 314 IFM, 2-1

F

FB41 "CONT_C", block diagram, 3-4

FB41 CONT_C, 3-2

 block diagram, 3-4

FB42 "CONT_S", block diagram, 3-11

FB42 CONT_S, 3-9

FB43 "PULSEGEN", block diagram, 3-16

FB43 PULSEGEN, 3-15

 automatic synchronization, 3-16

 three-step control, 3-18

 three-step control asymmetrical, 3-19

 two-step control, 3-20

I

Integrated control, 2-1

O

Online help, 1-2, 2-1

P

Parameter assignment user interface

 calling, 2-1

 online help, 2-1

PID Control, concept, 1-1

Process analysis, 1-1

Pulse duration modulation, 1-1, 3-15

PULSEGEN, 3-15

S

Step control, 1-1

Siemens AG
AUT E 146

Östliche Rheinbrückenstr. 50
D-76181 Karlsruhe
Federal Republic of Germany

From:

Your Name: _ _ _ _ _

Your Title: _ _ _ _ _

Company Name: _ _ _ _ _

Street: _ _ _ _ _

City, Zip Code _ _ _ _ _

Country: _ _ _ _ _

Phone: _ _ _ _ _

Please check any industry that applies to you:

- | | |
|--|--|
| <input type="checkbox"/> Automotive | <input type="checkbox"/> Pharmaceutical |
| <input type="checkbox"/> Chemical | <input type="checkbox"/> Plastic |
| <input type="checkbox"/> Electrical Machinery | <input type="checkbox"/> Pulp and Paper |
| <input type="checkbox"/> Food | <input type="checkbox"/> Textiles |
| <input type="checkbox"/> Instrument and Control | <input type="checkbox"/> Transportation |
| <input type="checkbox"/> Nonelectrical Machinery | <input type="checkbox"/> Other _ _ _ _ _ |
| <input type="checkbox"/> Petrochemical | |



